

Condensate Return Pumps



Condensate Return Pumps







Stand Alone Pressure Motive Pumps

Page No.

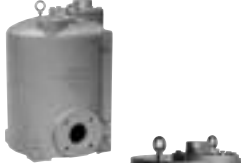
The stand alone **Pressure Motive Pump (PMP)** consists of the pump tank, the internal operating mechanism, and a set of inlet and outlet check valves. Depending on the particular model, pump tanks can be made from Ductile Iron, Fabricated Steel or Stainless Steel. In most installations an additional receiver or reservoir tank and possibly a high capacity steam trap may be required to complete the system.

76-89

Introduction Pressure Motive Pump (PMP) Series 76-81

	PMP	Basic Pumping Applications up to 200 PSIG <ul style="list-style-type: none"> • Ductile Iron body (PMO 200 PSIG) • Patented Snap-Assure Mechanism with Inlet and Outlet Check Valves 	82
	PMPF	Basic Pumping Applications up to 200 PSIG <ul style="list-style-type: none"> • Fabricated Carbon Steel body (PMO 200 PSIG) • Patented Snap-Assure Mechanism with Inlet and Outlet Check Valves 	83
	PMPSS	Corrosive Applications up to 150 PSIG <ul style="list-style-type: none"> • Fabricated Stainless Steel body (PMO 150 PSIG) • Patented Snap-Assure Mechanism with Inlet and Outlet Check Valves 	84
	PMPPLS	Low-Profile Applications up to 150 PSIG <ul style="list-style-type: none"> • Fabricated Carbon Steel body (PMO 150 PSIG) • Patented Snap-Assure Mechanism with Inlet and Outlet Check Valves 	85
	PMPM	Extremely Low-Profile Applications up to 150 PSIG <ul style="list-style-type: none"> • Cast Iron body (PMO 150 PSIG) • Internal Pump Mechanism with Inlet and Outlet Check Valves 	86
	PMPBP	High-Capacity Applications up to 150 PSIG <ul style="list-style-type: none"> • Fabricated Carbon Steel body (PMO 150 PSIG) • Internal Pump Mechanism with Inlet and Outlet Check Valves 	87
	PMPSP	Sump Drainer <ul style="list-style-type: none"> • Fabricated Carbon Steel body (PMO 150 PSIG) • These non-electric sump drainers are designed to drain unwanted water from sumps, pits, underground tunnels and low lying areas • Patented Snap-Assure Mechanism with Inlet and Outlet Check Valves 	88-89

Condensate Return Pumps

Pumps with Receiver Tanks

Page No.



Simplex, Duplex, Triplex & Quadraplex Systems

90-91

Standardized Simplex, Duplex, Triplex, and Quadraplex packaged systems include the Stand Alone Pumps and check valves with receiver tank mounted on a steel base and frame. Multiple pumping units can be used for increased capacity or for system redundancy. The units are available in Ductile Iron, Carbon Steel and Stainless Steel.

Additional options such as sight glasses, insulation jackets, cycle counters, motive and vent piping, pressure regulators, steam traps, strainers and ASME code stamps, etc., are available.

Pump & Trap Combinations

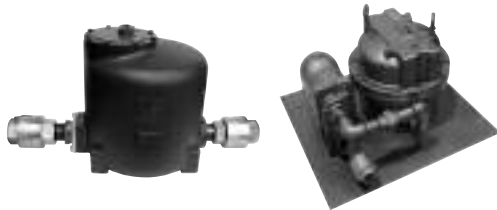

Models PMPT & WPT

92-97

Pump & trap combinations are used for draining condensate from a single piece of heat transfer equipment. Model PMPT has an internal steam trap inside the pump body. The WPT Series have an appropriately sized external steam trap attached to the pump and are mounted on a common base.

ACCESSORIES & OPTIONS for Stand Alone Units

Custom Tanks, Insulation Jackets, Gauge Glasses, Cycle Counters, Pre-piped Accessories, Mechanisms, Check Valves, etc.

98-99

SIZING & SELECTION for All Non-Electric Pumps & Systems

Pump Capacities

100-101

PMP, Receiver & Vent, Pump-Trap & Reservoir Sizing

102-109

Customized Skid Packages

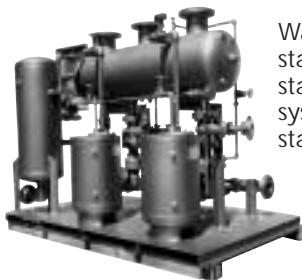

Watson McDaniel's fully equipped ASME qualified fabrication facility stands ready to assist you with all your fabrication needs. Our engineering staff specializes in the design of pressure motive condensate pumping systems for both industrial and institutional applications. We offer either standard packages, or specialized systems to meet your specific needs.

110-111

Electric Condensate Pumps



Models W4100 & W4200

112-115

Electric condensate pumps are available for condensate temperatures up to 190°F. Carbon Steel and Cast Iron Tanks available. Available options include receivers, NEMA control panels, mechanical and electrical alternators, magnetic starters, gauge glasses, and more.

Pumps NON-ELECTRIC CONDENSATE PUMPS

Why use a Pressure Motive Pump (PMP)?

The primary function of the non-electric PMPs is to return condensate back to the boiler. They are an excellent alternative to standard electric pumps that are prone to seal failure when pumping hot condensate in excess of 195° F. They also significantly improve the performance and efficiency of heat exchangers by helping to drain condensate from the heat exchanger during system stall conditions.

Information Required for Proper Selection and Sizing of Pressure Motive Pump (PMP) Systems

Although Pressure Motive Pumps can be supplied as stand-alone units, the vast majority of industrial condensate transfer applications require a complete system of components to function both properly and efficiently. This section is intended to familiarize the user with the information and components required to provide an efficient system.

Considerations for PMP System Sizing and Selection

- 1) Is a PMP required for the situation? Is there sufficient line pressure for adequate transfer of condensate, or is a PMP required to overcome lift and/or condensate return line pressure?
- 2) Should you choose a Stand-alone pump or Pump with Receiver Tank (PMP System)? The vast majority of pump applications require some type of receiver or reservoir upstream of the unit for several possible reasons:



- To allow proper operation of the PMP by providing adequate liquid head above the PMP (Fill Height). Liquid fill head is required to ensure gravity drainage of condensate so that the PMP tank may fill completely on each cycle.
- To enable the condensate to collect while the pump is in the discharge cycle (i.e. not filling), thus preventing liquid backup into the equipment being drained.
- In an open loop system, a vented receiver must accommodate both high pressure/temperature condensate as well as the flash steam generated from that condensate. Sizing of both the receiver and vent connection are critical to proper function of the system.

- 3) Application – **OPEN LOOP** (Vented Receiver) or **CLOSED LOOP** (Pressurized Reservoir)?

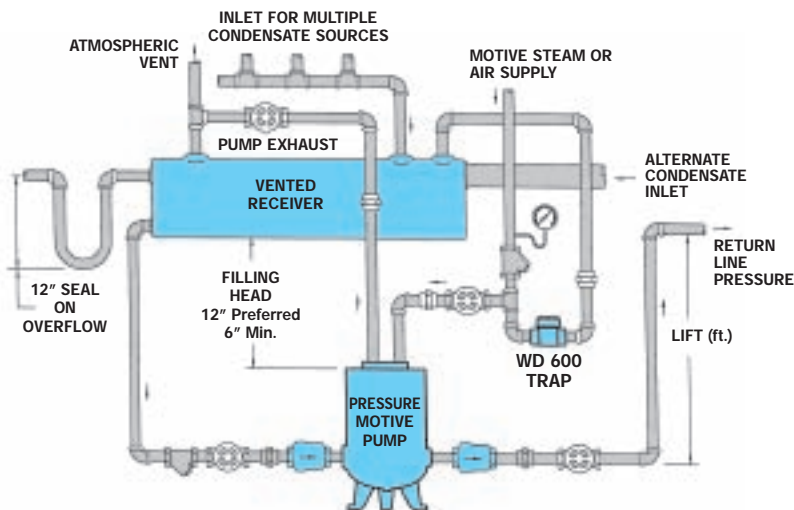

▶ OPEN LOOP (Vented Receiver)

This PMP System is intended for the drainage of multiple condensate sources. For these applications, a vented receiver will be required for the equalization of the various pressure sources. The flash steam generated by the hot condensate in the receiver tank can be used for supplementing other low pressure steam systems or vented to atmosphere.

Pumps NON-ELECTRIC CONDENSATE PUMPS

▶ CLOSED LOOP (Pressurized Reservoir)

STALL CONDITION WITH MODULATED STEAM FLOW

When a modulating valve is used to control product temperature in heat transfer equipment, the valve will open and close as necessary to meet the variable demand of the system to maintain the product at constant temperature (Figure 1). Therefore, when maximum heating is required, the supply valve will be fully open to satisfy the high steam demand requirement. At this point, pressure is also being supplied at its highest level, which may be sufficient to overcome total system back pressure.

As the product temperature is satisfied, demand decreases and the valve correspondingly begins to close reducing pressure differential. If demand is satisfied, the valve modulates to its fully closed position. Inlet supply pressure will eventually fall below system back pressure, resulting in system stall. This leads to poor heat transfer and water hammer as condensate backs up in the heat transfer equipment. To prevent this situation, a pressure motive pump (PMP) and steam trap is added to the system (Figure 2). Any condensate forming inside the heat transfer equipment will drain by gravity into the pump tank. The condensate will accumulate in the pump tank until the float mechanism reaches its trip point. The “tripping” of the mechanism opens the motive valve to allow high pressure steam into the tank to drive the condensate from the tank to the condensate return line.

Figure 1

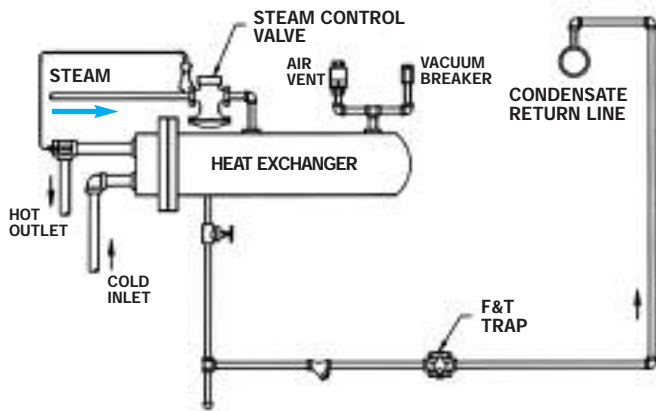

Heat Exchanger System without PMP

Figure 2

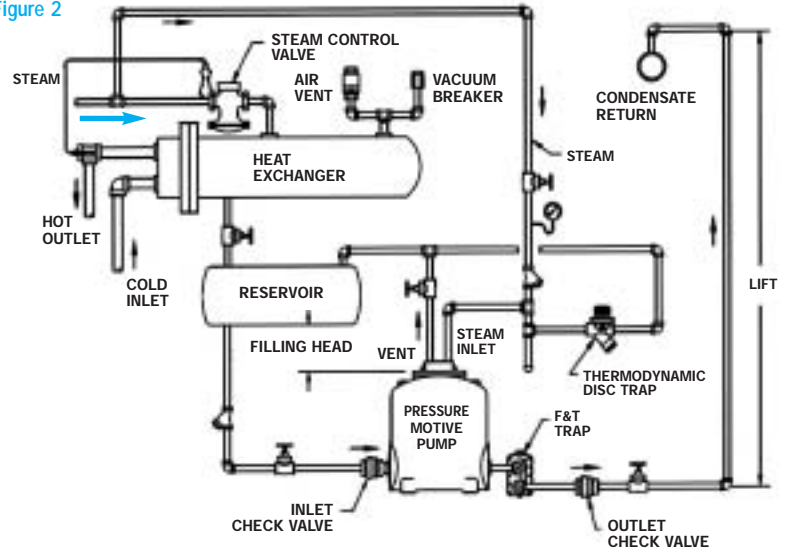

Heat Exchanger System with PMP & Separate Trap (Closed Loop System)

- 4) Height or spatial limitations – Is the equipment to be drained low to the ground or are there other size limitations? It is important that minimum fill head requirements are met to ensure proper operation of the PMP. In addition, changes in fill head will affect capacity.
- 5) Standard Simplex/Duplex/Triplex/Quadruplex or Custom System – This is generally dictated by sizing requirements and application parameters, but a cost-effective standard system should be selected when possible. Custom fabricated systems are designed to meet a wide variety of specific application requirements. Note: The sizing of the receiver and vent connection on standard systems must be specified per the application parameters.
- 6) Back pressure – For proper sizing and selection of a PMP system, the total back pressure of the system must be known. The total back pressure generally consists of:
 - The vertical height the condensate must be raised (Every 1 foot of vertical lift equals 0.433 PSI pressure.)
 - Any line pressure in the condensate return piping
- 7) Motive Gas and Pressure – Is the gas (steam, air, other) appropriate for the application and is the available pressure sufficient to provide the necessary flow against the total back pressure? (For closed loop systems, only steam is appropriate as a motive.)

NON-ELECTRIC CONDENSATE PUMPS

PMP Series

Pressure Motive Pumps

Watson McDaniel reserves the right to change the designs and/or materials of its products without notice.
©2010 Watson McDaniel Company

TYPICAL APPLICATIONS

The Watson McDaniel PMP Series of Pressure Motive Pumps are designed to transfer hot condensate (as well as other liquids) without the use of electrical energy. The primary application for the PMP is pumping condensate from a process application or condensate collection area back to the condensate return system.

Hot Condensate The mechanical seals in standard electric condensate return pumps begin to have difficulty when handling condensate in excess of 195° F. Seal failure is virtually guaranteed when condensate temperatures reach 203° F due to flashing of the condensate across the seal face. It is therefore required to cool condensate in order to prevent seal failure prior to pumping using electric pumps. PMPs do not have seals and therefore will handle condensate well in excess of these temperatures.

TYPICAL CONFIGURATIONS

STAND ALONE UNITS:

All stand alone units are furnished with pump tank, check valves and internal pumping mechanism.

- PMPC • PMPF • PMPSS • PMPLS • MPPM • PMPBP

PUMPS WITH RECEIVER TANKS:

One or more stand alone pump units connected to an appropriately sized receiver tank mounted on a common base. Additional pumping units can be used for increased capacity or pump redundancy in case of failure.

Simplex: One Pumping unit with check valves and receiver tank, mounted on frame and skid base.

Duplex: Two Pumping units with check valves and receiver tank, mounted on frame and skid base.

Triplex: Three Pumping units with check valves and receiver tank, mounted on frame and skid base.

Quadraplex: Four Pumping units with check valves and receiver tank, mounted on frame and skid base.

PUMP & STEAM TRAP COMBINATIONS:

Stand alone pump combined with Internally or Externally configured Steam Trap.

- PMPT (Internal Steam Trap)
- WPT Series (External Steam Trap)

SUMP DRAINER:

Stand alone Sump Drainer with check valves is designed for pumping water out of low lying areas or pits. Excellent solution where there is no access to electricity.

- PMSP

CUSTOM CONFIGURATIONS

Watson McDaniel's fully-qualified fabrication facility is ASME code certified. Our engineers can design and build complete custom systems to meet all your requirements.

Several choices of pump body materials, types and configurations are available to meet specific customer applications:

Ductile Iron Tanks Ductile Iron is far superior to cast iron in handling higher pressures and temperatures. Ductile iron is also extremely corrosion resistant to condensate and water and can last in excess of 50 years before tank replacement is required. Our ductile iron tanks can be ASME coded on request.

Fabricated Carbon Steel Carbon steel has a higher pressure and temperature rating than ductile iron. Certain industrial facilities such as chemical and petrochemical refineries request carbon steel only. Our carbon steel tanks are standard ASME coded.

Fabricated Stainless Steel Stainless steel (304L) tanks are the most corrosion resistant and can be used in extremely harsh environments.

Low Profile Low profile tanks are often required when draining condensate from process equipment when positioned close to the ground which limits filling head. Low profile units are available in both fabricated steel and cast iron.

Sump Drainers Sump drainers are similar to the standard PMP models except that they discharge the condensate vertically upwards. This piping configuration allows them to easily fit into below ground sump pits with limited space.

FEATURES

- **Seal-less** – The PMP contains no seals. The weak point in conventional electric pumps is seal failure due to flashing hot condensate across the seal face.
- **Non-Electric** – Since no electricity is required they can be used in remote locations or NEMA 4, 7 & 9 hazardous areas. Can operate using steam, air, nitrogen or other pressurized gases as the motive force.
- **Ductile-Iron** – Pump tanks are standard in Ductile Iron which is far superior to Cast Iron for pressure and temperature rating and safety. Can be ASME coded and can last in excess of fifty years prior to replacement.
- **Carbon Steel** – Pump tanks available in ASME coded carbon steel.
- **Stainless Steel** – Pump tank options include 304L for applications in harsh environments.

OPTIONS

- Pump cycle counter used for predicting maintenance intervals as well as calculating the volume of condensate pumped.
- Insulation jackets are available to stop heat losses through the pump body and provide personal protection.
- Sight glass for monitoring liquid level inside pump body.
- Customized systems – ASME code-certified fabrication facility

NON-ELECTRIC CONDENSATE PUMPS

PMP Series

Pressure Motive Pumps

STAND ALONE UNITS

All stand alone units are furnished with pump tank, check valves and internal pumping mechanism.



PMPC DUCTILE IRON

The Model PMPC pressure motive pump body & cover are manufactured from ductile iron. ASME "UM" code stamp is available.



PMPF CARBON STEEL HIGH-PRESSURE

The Model PMPF pressure motive pump is designed for high pressure applications. Pump body & cover are manufactured from carbon steel and receive the ASME "UM" code stamp.



PMPSS STAINLESS STEEL

The Model PMPSS pressure motive pump body & cover are manufactured from 304L stainless steel. These tanks are designed to be used in harsh corrosive environments and receive the ASME "UM" code stamp.



PMPBP CARBON STEEL HIGH-CAPACITY

The PMPBP is an extremely high-capacity pressure motive pump for applications requiring large transfer of condensate or other liquids. The internal operating mechanism functions identically to other pumps in the PMP series. ASME "U" code stamp is available.



PMPM CAST IRON LOW PROFILE

The Model PMPM pressure motive pump has an extremely low profile. These low-profile tanks are required when draining condensate from process equipment positioned close to the ground which limits the filling head of the pump.



PMPLS CARBON STEEL LOW PROFILE

The Model PMPLS pressure motive pumps are low profile. These tanks are often required when draining condensate from process equipment positioned close to the ground which limits the filling head of the pump. Pump body & cover are manufactured from carbon steel and receive the ASME "UM" code stamp.

PUMP & TRAP COMBINATIONS

with Internal Steam Trap



PMPT

The Model PMPT low-profile pressure motive pump comes with an Internal Steam Trap. It is an excellent choice for drainage of various modulating process equipment. The internal steam trap allows condensate discharge under all operating conditions of modulating equipment, including vacuum.

with External Steam Trap



WPT

The WPT Series are stand alone pump units with an appropriately sized External Steam Trap preassembled at the factory and mounted on a common base plate, allowing for easy installation. Available in several sizes and capacities. Used when load requirement exceeds that of the PMPT.

PUMPS WITH RECEIVER TANKS



Watson McDaniel manufactures PMPs with receiver tanks. Pumps are available in Ductile Iron, Cast Iron or Fabricated Steel. Receiver tank manufactured from Carbon Steel. Available in Simplex, Duplex, Triplex and Quadraplex.

SUMP DRAINER



PMPSP

The Model PMPSP sump drainer body & cover are manufactured from Carbon Steel. The Model PMPSP Sump Drainer is designed for pumping out and draining pits.

NON-ELECTRIC CONDENSATE PUMPS

PMP Series

Pressure Motive Pumps

Watson McDaniel reserves the right to change the designs and/or materials of its products without notice.
©2010 Watson McDaniel Company

PUMPS

Operation of PMP Pressure Motive Pump

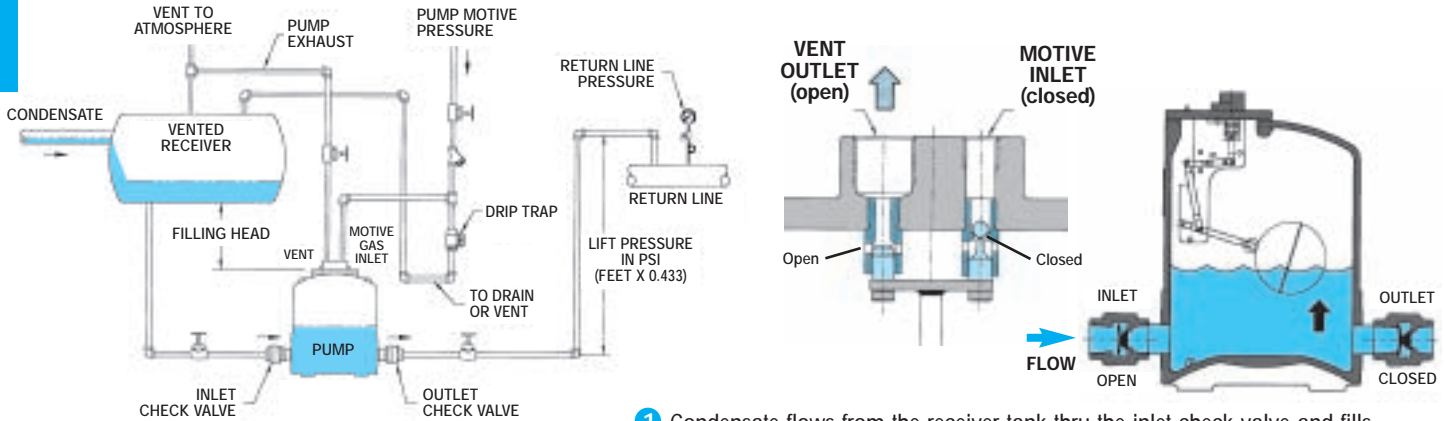

1 Condensate flows from the receiver tank thru the inlet check valve and fills the pump tank. During the filling cycle the float inside the tank rises.

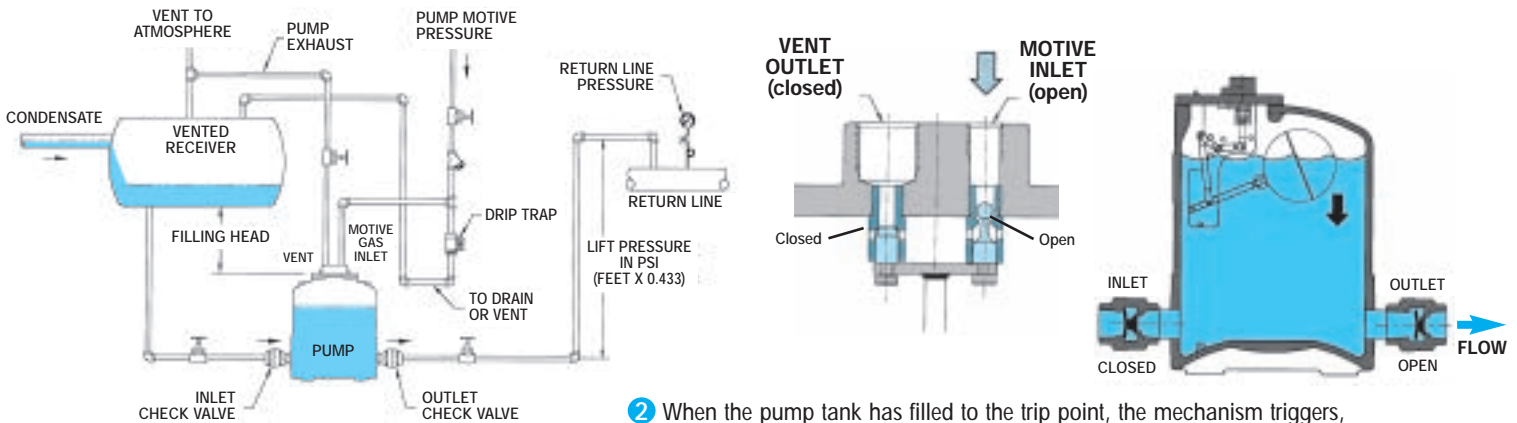

2 When the pump tank has filled to the trip point, the mechanism triggers, opening the motive gas inlet valve and simultaneously closing the vent valve. This allows motive pressure to enter the pump body, which drives the condensate thru the outlet check valve into the condensate return line. During the discharge cycle, the liquid level and the float inside the pump tank drop.

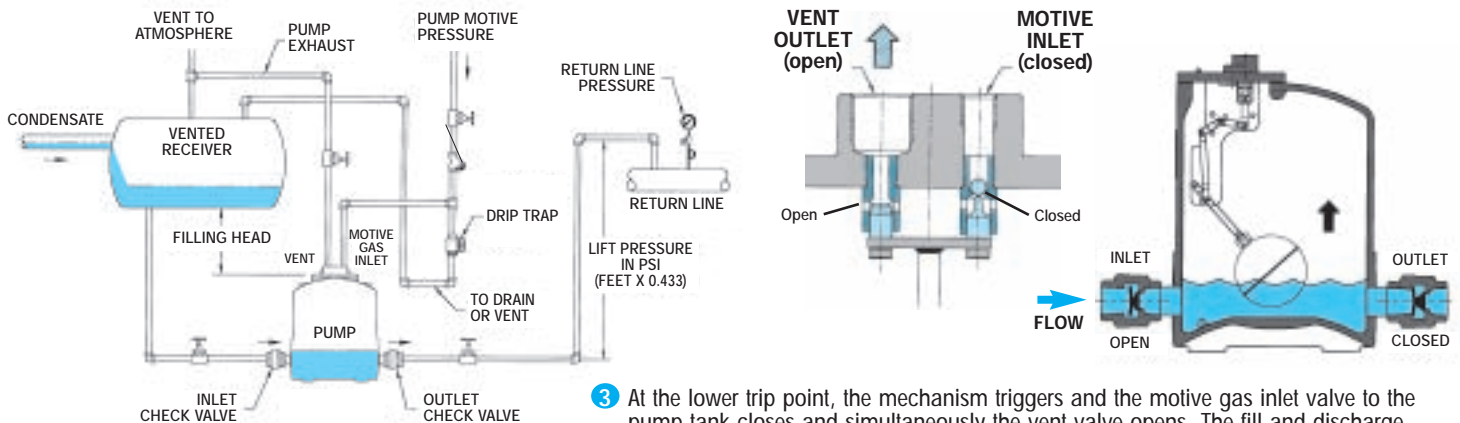

3 At the lower trip point, the mechanism triggers and the motive gas inlet valve to the pump tank closes and simultaneously the vent valve opens. The fill and discharge cycle then repeats itself.

NON-ELECTRIC CONDENSATE PUMPS

PMP Series

Pressure Motive Pump Internal Mechanism

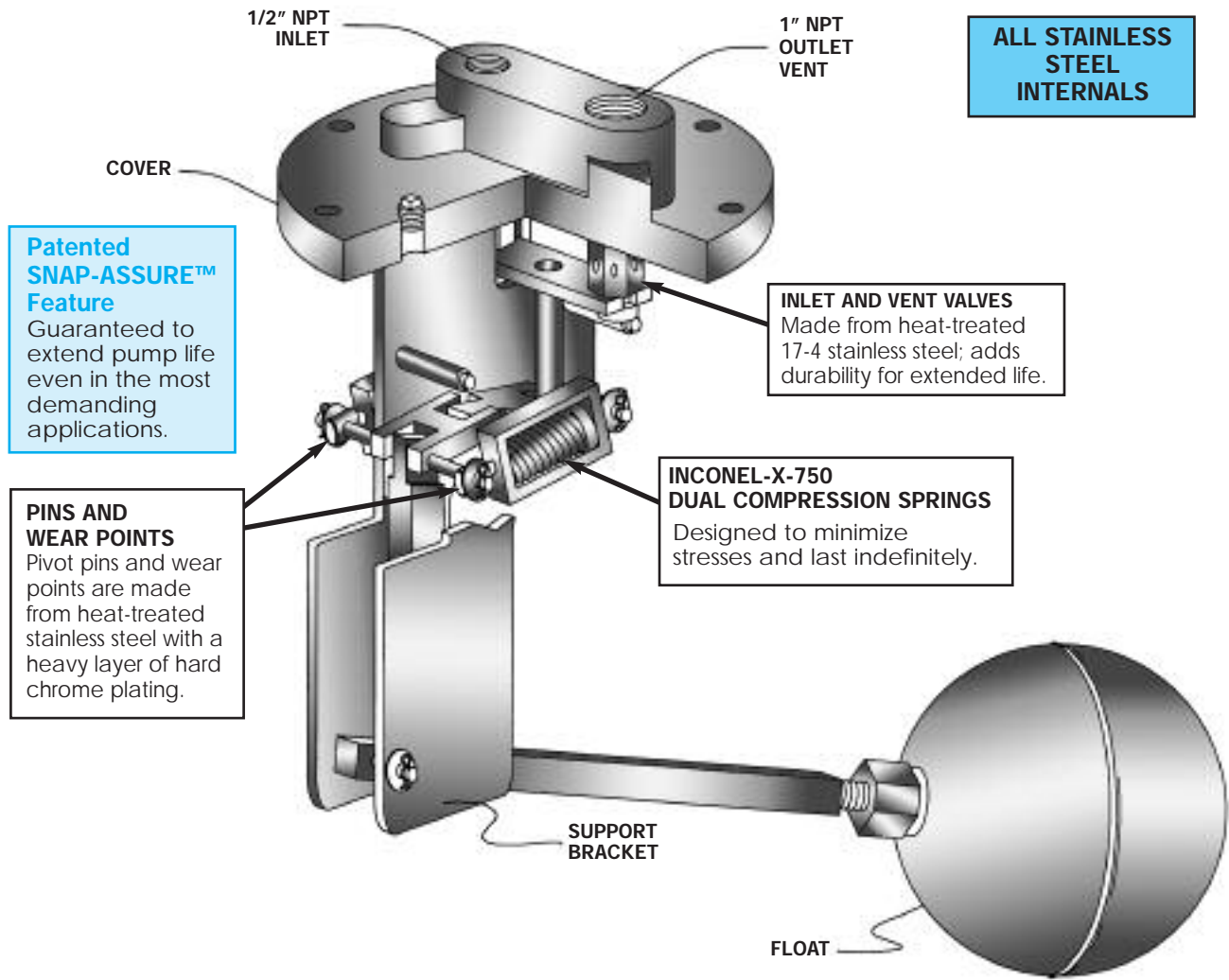

ALL STAINLESS STEEL INTERNALS

Patented SNAP-ASSURE™ Feature
Guaranteed to extend pump life even in the most demanding applications.

INLET AND VENT VALVES
Made from heat-treated 17-4 stainless steel; adds durability for extended life.

INCONEL-X-750 DUAL COMPRESSION SPRINGS
Designed to minimize stresses and last indefinitely.

PINS AND WEAR POINTS
Pivot pins and wear points are made from heat-treated stainless steel with a heavy layer of hard chrome plating.

INTERNAL MECHANISM FEATURES

- Equipped with our Patented “Snap-Assure” feature, found only on Watson McDaniel’s mechanisms. “Snap-Assure” extends the useful life of the pump by assuring that the internal toggle action triggers at every fill and discharge cycle
- All Stainless Steel components eliminate corrosion and rusting
- Hard chrome-plated pivot pins and wear points substantially reduce the rate of wear on critical components
- 17-4 heat-treated stainless steel inlet and vent valve (Hardened seats have proven themselves to last years longer in service)
- Dual compression springs made from Inconel-X-750 minimize stress and corrosion and are designed to last indefinitely
- Precision manufactured mechanisms never require field adjustments
- Watson McDaniel “Snap-Assure” mechanisms can be purchased separately and will fit other manufacturers’ pump tanks

INTERNAL MECHANISM MATERIALS

Cover	Material for cover same as tank material
Cover Gasket	Garlock / Grafoil
Cover Bolts	Grade B5
Inlet Valve	Hardened Stainless Steel, Rc 40
Vent Valve	Hardened Stainless Steel, Rc 40
Mechanism Yoke	304 Stainless Steel
Ball Float	Stainless Steel
Springs	Inconel-X-750
Other Internal Parts	Stainless Steel

Snap-Assure Patent No. 6572340

NON-ELECTRIC CONDENSATE PUMPS

PMPC CAST DUCTILE IRON TANK

Pressure Motive Pump

Watson McDaniel reserves the right to change the designs and/or materials of its products without notice.
©2010 Watson McDaniel Company

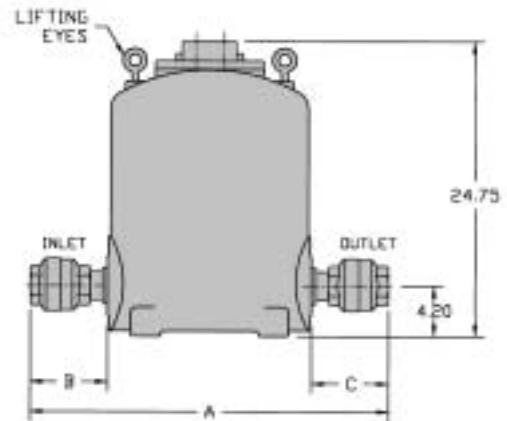
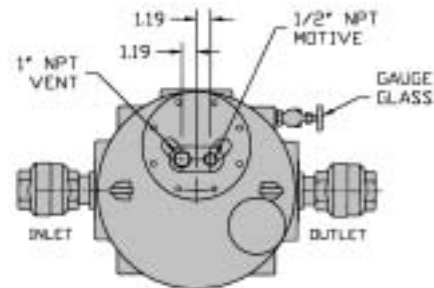

Model	PMPC
Body	Ductile Iron
Cover	Ductile Iron
Check Valves	Stainless Steel
PMO Max. Operating Pressure	200 PSIG
TMO Max. Operating Temperature	388°F
PMA Max. Allowable Pressure	200 PSIG @ 650°F
TMA Max. Allowable Temperature	650°F @ 200 PSIG

Note: ASME "UM" code stamp available.

TYPICAL APPLICATIONS

The PMPC pressure motive pump body & cover are manufactured from ductile iron. ASME "UM" code stamp is available. This pump is typically used when liquids must be moved to higher elevation, higher pressure or extended distances.

FEATURES

- Equipped with our Patented "Snap-Assure" Mechanism which extends the useful life of the pump
- Mechanism incorporates heat-treated stainless steel wear items
- All stainless steel internals for ultimate corrosion resistance
- Dual compression springs made from Inconel-X-750 for high-temperature corrosive service
- Operates using steam, air, nitrogen or other pressurized gases as the motive force
- Non-Electric – can be used in remote locations or NEMA 4, 7, 9 & hazardous areas

SAMPLE SPECIFICATION

The non-electric pressure powered pump shall be capable of operating with a maximum motive pressure of 200 PSIG provided by steam, air or other gas supply. The pump body shall be cast ASTM A-395 Ductile Iron capable of an ASME "UM" code stamp if requested. The pump mechanism shall be float operated with a patented "Snap-Assure" feature constructed of all stainless steel materials with all load bearing points hardened for extended service life. The mechanism shall feature two Inconel springs used in compression with motive & vent valves hardened to 40c Rockwell.

DIMENSIONS – inches / pounds

Size (Inlet x Outlet)	A	B	C	Weight (lbs)
1" x 1"	29 1/2	6	6	360
1 1/2" x 1"	30 3/4	7 1/2	6	365
1 1/2" x 1 1/2"	31 1/4	7 1/2	7 1/2	367
2" x 1"	31	8	6	370
2" x 1 1/2"	32 1/2	8	7 1/2	380
2" x 2"	32 3/4	8	8	385
3" x 2"	35 1/4	9 1/4	8	390

MATERIALS

Body & Cover	Ductile Iron
Cover Gasket	Grafoil
Cover Bolts	Steel
Inlet Valve	Hardened Stainless Steel 40 Rc
Vent Valve	Hardened Stainless Steel 40 Rc
Mechanism Yoke	304 Stainless Steel
Ball Float	304 Stainless Steel
Check Valves	Stainless Steel
Springs	Inconel-X-750
Other Internal Components	Stainless Steel

Snap-Assure Patent No. 6572340

NON-ELECTRIC CONDENSATE PUMPS

FABRICATED STEEL TANK **PMPF**

Pressure Motive Pump

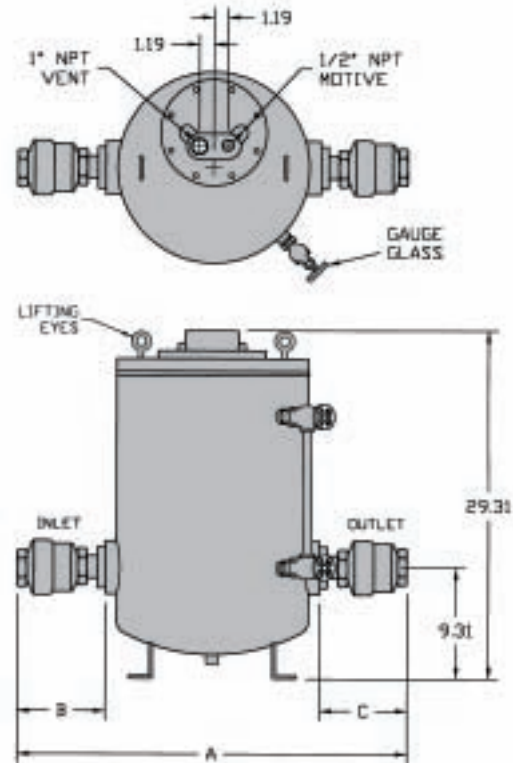

Model	PMPF
Body	Carbon Steel
Cover	Carbon Steel
Check Valves	Stainless Steel
PMO Max. Operating Pressure	200 PSIG
TMO Max. Operating Temperature	388°F
PMA Max. Allowable Pressure	250 PSIG @ 650°F

TYPICAL APPLICATIONS

The PMPF pressure motive pump body & cover are manufactured from carbon steel. These tanks are fabricated with 1/8" corrosion allowance and receive the **ASME "UM"** code stamp. This pump is typically used when liquids must be moved to higher elevation, higher pressure or extended distances.

FEATURES

- Equipped with our **Patented "Snap-Assure" Mechanism** which extends the useful life of the pump
- Mechanism incorporates heat-treated stainless steel wear items
- All stainless steel internals for ultimate corrosion resistance
- Dual compression springs made from **Inconel-X-750** for high-temperature corrosive service
- Operates using steam, air, nitrogen or other pressurized gases as the motive force
- **Non-Electric** – can be used in remote locations or **NEMA 4, 7, 9 & hazardous areas**

SAMPLE SPECIFICATION

The non-electric pressure powered pump shall be capable of operating with a maximum motive pressure of 200 PSIG provided by steam, air or other gas supply. The pump body shall be fabricated carbon steel and certified with the ASME "UM" code stamp. The pump mechanism shall be float operated with a patented "Snap-Assure" feature constructed of all stainless steel materials with all load bearing points hardened for extended service life. The mechanism shall feature two Inconel springs used in compression with motive & vent valves hardened to 40c Rockwell.

DIMENSIONS – inches / pounds				
Size (Inlet x Outlet)	A	B	C	Weight (lbs)
1" x 1"	30 ¹ / ₂	6	6	215
1 ¹ / ₂ " x 1"	31 ³ / ₄	7 ¹ / ₂	7 ¹ / ₂	220
1 ¹ / ₂ " x 1 ¹ / ₂ "	32 ¹ / ₄	7 ¹ / ₂	6	223
2" x 1"	32	8	6	225
2" x 1 ¹ / ₂ "	33 ¹ / ₂	8	7 ¹ / ₂	230
2" x 2"	33 ³ / ₄	8	8	235
3" x 2"	35 ¹ / ₄	9 ¹ / ₄	8	240

MATERIALS

Body & Cover	Carbon Steel
Cover Gasket	Grafoil
Cover Bolts	Steel
Inlet Valve	Hardened Stainless Steel 40 Rc
Vent Valve	Hardened Stainless Steel 40 Rc
Mechanism Yoke	304 Stainless Steel
Ball Float	304 Stainless Steel
Check Valves	Stainless Steel
Springs	Inconel-X-750
Other Internal Components	Stainless Steel

Snap-Assure Patent No. 6572340

NON-ELECTRIC CONDENSATE PUMPS

PMPSS STAINLESS STEEL TANK

Pressure Motive Pump

Watson McDaniel reserves the right to change the designs and/or materials of its products without notice.
©2010 Watson McDaniel Company

PUMPS

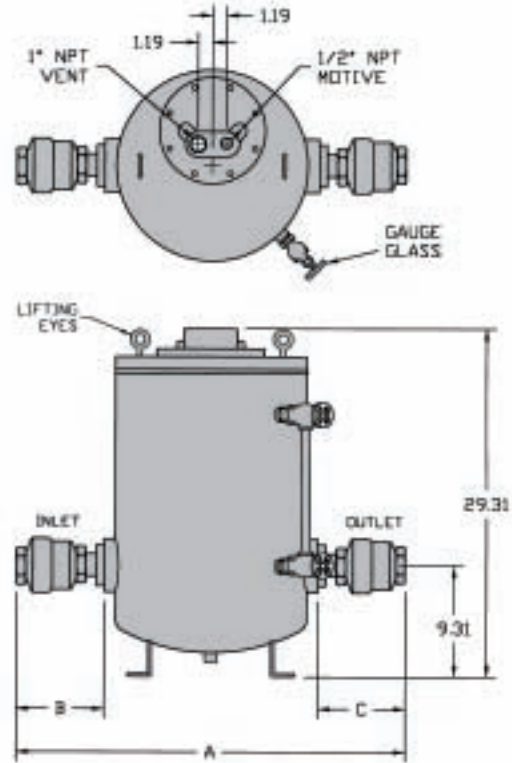

Model	PMPSS
Body	304L Stainless Steel *
Cover	Carbon Steel
Check Valves	Stainless Steel
PMO Max. Operating Pressure	150 PSIG
TMO Max. Operating Temperature	366 °F
PMA Max. Allowable Pressure	150 PSIG @ 650°F

* For special 316L SS, consult factory.

TYPICAL APPLICATIONS

The PMPSS pressure motive pump body & cover are manufactured from 304L Stainless Steel. These pumps receive the ASME "UM" code stamp. This pump is designed to be used in harsh and corrosive environments.

FEATURES

- Equipped with our Patented "Snap-Assure" Mechanism which extends the useful life of the pump
- Mechanism incorporates heat-treated stainless steel wear items
- All stainless steel internals for ultimate corrosion resistance
- Dual compression springs made from Inconel-X-750 for high-temperature corrosive service
- Operates using steam, air, nitrogen or other pressurized gases as the motive force
- Non-Electric – can be used in remote locations or NEMA 4, 7, 9 & hazardous areas

SAMPLE SPECIFICATION

The non-electric pressure powered pump shall be capable of operating with a maximum motive pressure of 150 PSIG provided by steam, air or other gas supply. The pump body shall be 304L Stainless Steel and certified with the ASME "UM" code stamp. The pump mechanism shall be float operated with a patented "Snap-Assure" feature constructed of all stainless steel materials with all load bearing points hardened for extended service life. The mechanism shall feature two Inconel springs used in compression with motive & vent valves hardened to 40c Rockwell.

DIMENSIONS – inches / pounds

Size (Inlet x Outlet)	A	B	C	Weight (lbs)
1" x 1"	30 1/2	6	6	215
1 1/2" x 1"	31 3/4	7 1/2	7 1/2	220
1 1/2" x 1 1/2"	32 1/4	7 1/2	6	223
2" x 1"	32	8	6	225
2" x 1 1/2"	33 1/2	8	7 1/2	230
2" x 2"	33 3/4	8	8	235
3" x 2"	35 1/4	9 1/4	8	240

MATERIALS

Body & Cover	304L Stainless Steel
Cover Gasket	Grafoil
Cover Bolts	Steel
Inlet Valve	Hardened Stainless Steel 40 Rc
Vent Valve	Hardened Stainless Steel 40 Rc
Mechanism Yoke	304 Stainless Steel
Ball Float	304 Stainless Steel
Check Valves	Stainless Steel
Springs	Inconel-X-750
Other Internal Components	Stainless Steel

Snap-Assure Patent No. 6572340

NON-ELECTRIC CONDENSATE PUMPS

CARBON STEEL LOW-PROFILE TANK **PMPLS**

Pressure Motive Pump

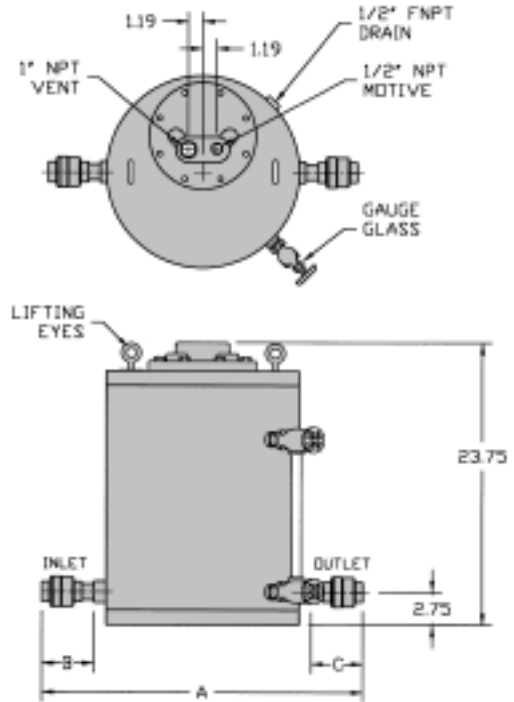

Model	PMPLS
Body	Carbon Steel
Cover	Carbon Steel
Check Valves	Stainless Steel
PMO Max. Operating Pressure	150 PSIG
TMO Max. Operating Temperature	366°F
PMA Max. Allowable Pressure	150 PSIG @ 650°F

Note: Optional 200 PSIG PMA/PMO. Consult Factory.

TYPICAL APPLICATIONS

The PMPLS pressure motive pump is a lower profile than the standard PMPF model and is sometimes required when draining condensate from process equipment that is positioned close to the ground which limits the filling head of the pump. Pump & body cover are manufactured from carbon steel and receive the ASME "UM" code stamp.

FEATURES

- Equipped with our Patented "Snap-Assure" Mechanism which extends the useful life of the pump
- Mechanism incorporates heat-treated stainless steel wear items
- All stainless steel internals for ultimate corrosion resistance
- Dual compression springs made from Inconel-X-750 for high-temperature corrosive service
- Operates using steam, air, nitrogen or other pressurized gases as the motive force
- Non-Electric – can be used in remote locations or NEMA 4, 7, 9 & hazardous areas

SAMPLE SPECIFICATION

The non-electric pressure powered pump shall be capable of operating with a maximum motive pressure of 150 PSIG provided by steam, air or other gas supply. The pump body shall be fabricated carbon steel and certified with the ASME "UM" code stamp. The pump mechanism shall be float operated with a patented "Snap-Assure" feature constructed of all stainless steel materials with all load bearing points hardened for extended service life. The mechanism shall feature two Inconel springs used in compression with motive & vent valves hardened to 40c Rockwell.

DIMENSIONS – inches / pounds				
Size (Inlet x Outlet)	A	B	C	Weight (lbs)
1" x 1"	29 ¹ / ₂	5 ⁵ / ₈	5 ⁵ / ₈	200
1 ¹ / ₂ " x 1"	30 ³ / ₄	7	5 ⁵ / ₈	205
1 ¹ / ₂ " x 1 ¹ / ₂ "	32 ¹ / ₈	7	7	210

MATERIALS

Body & Cover	Carbon Steel
Cover Gasket	Grafoil
Cover Bolts	Steel
Inlet Valve	Hardened Stainless Steel 40 Rc
Vent Valve	Hardened Stainless Steel 40 Rc
Mechanism Yoke	304 Stainless Steel
Ball Float	304 Stainless Steel
Check Valves	Stainless Steel
Springs	Inconel-X-750
Other Internal Components	Stainless Steel

Snap-Assure Patent No. 6572340

NON-ELECTRIC CONDENSATE PUMPS

PMPM CAST IRON MINI-PUMP

Watson McDaniel reserves the right to change the designs and/or materials of its products without notice.
©2010 Watson McDaniel Company

Pressure Motive Pump

PUMPS

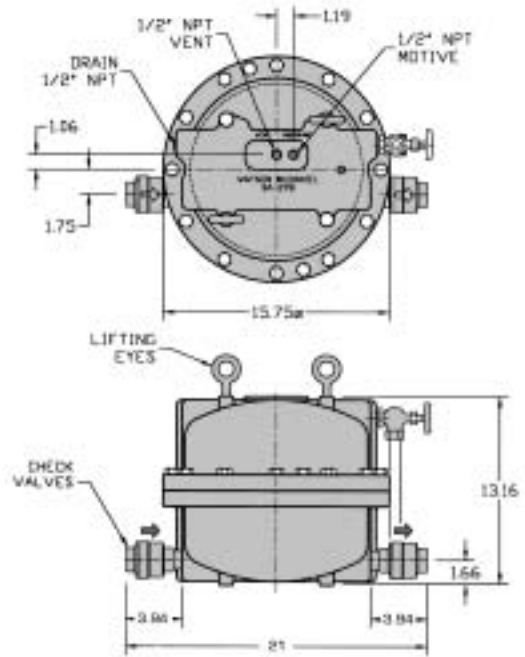

Model	PMPM
Body	Cast Iron
Cover	Cast Iron
Sizes	1", 1 1/4"
Check Valves	Stainless Steel
PMO Max. Operating Pressure	150 PSIG
TMO Max. Operating Temperature	366°F
PMA Max. Allowable Pressure	150 PSIG @ 450°F

TYPICAL APPLICATIONS

The Model PMPM pressure motive pump has an *extremely low profile*. These low-profile tanks are required when draining condensate from process equipment positioned close to the ground which limits the filling head of the pump.

FEATURES

- Mechanism incorporates heat-treated stainless steel wear items for extended service life
- All stainless steel internals for ultimate corrosion resistance
- Dual springs made from Inconel-X-750 for high-temperature corrosive service
- Operates using steam, air, nitrogen or other pressurized gases as the motive force
- Low-profile design
- Non-Electric – can be used in remote locations or NEMA 4, 7, 9 & hazardous areas

MATERIALS

Body & Cover	Cast Iron
Cover Gasket	Garlock
Cover Bolts	Steel
Inlet Valve	Hardened Stainless Steel 40 Rc
Vent Valve	Hardened Stainless Steel 40 Rc
Mechanism Yoke	304 Stainless Steel
Ball Float	304 Stainless Steel
Check Valves	Stainless Steel
Springs	Inconel-X-750
Other Internal Components	Stainless Steel

CAPACITIES – Condensate (lbs/hr)

Motive Pressure (PSIG)	Back Pressure (PSIG)	6" Filling Head			
		Steam Motive		Air Motive	
		1"	1 1/4"	1"	1 1/4"
25	15	1200	1800	1720	2580
25	5	1970	2955	2265	3398
50	40	1200	1800	1640	2460
50	25	1480	2220	1980	2970
50	15	1860	2790	2220	3330
50	5	2240	3360	2485	3728
75	60	1160	1740	1935	2903
75	40	1640	2460	2185	3278
75	25	1960	2960	2340	3510
100	60	1415	2122	2020	3030
100	40	1825	2732	2280	3420
100	25	1985	2977	2420	3630
100	15	2175	3262	2455	3683
150	100	1120	1680	1456	2184
150	80	1220	1830	1525	2288
150	60	1570	2355	1885	2828

SIZING

The capacity of the PMPM is based on the inlet steam pressure, the system back pressure, and the amount of filling head available. The trap used in a pump-trap combination must be sized to handle the instantaneous discharge of the pump.

Choose a F&T trap that will pass the condensate load at a 1/4 PSI differential pressure. The PMO of the steam trap must be higher than the motive inlet steam pressure. Consult factory for proper choice of steam trap.

NON-ELECTRIC CONDENSATE PUMPS

CARBON STEEL HIGH-CAPACITY TANK **PMPBP** Pressure Motive Pump

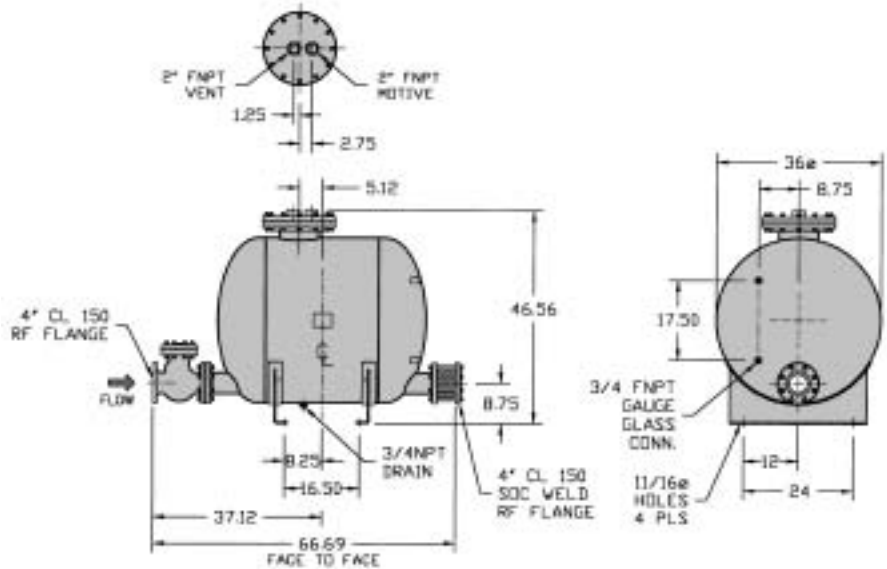

Model	PMPBP
Body	Carbon Steel
Cover	Carbon Steel
Check Valves	Stainless Steel & Steel
PMO Max. Operating Pressure	150 PSIG
TMO Max. Operating Temperature	366°F
PMA Max. Allowable Pressure	150 PSIG @ 470°F

MATERIALS

Body & Cover	Carbon Steel
Cover Gasket	Non-Asbestos
Cover Bolts	Steel
Inlet Valve	Stainless Steel
Vent Valve	Stainless Steel
Mechanism Yoke	304 Stainless Steel
Ball Float	304 Stainless Steel
Check Valves	Stainless Steel & Steel
Springs	Stainless Steel
Other Internal Components	Stainless Steel

TYPICAL APPLICATIONS

The PMPBP is an *extremely high-capacity* pressure motive pump for applications requiring large transfer of condensate or other liquids. The internal operating mechanism functions identically to other pumps in the PMP series. ASME "U" code stamp is available.

FEATURES

- All stainless steel internals for ultimate corrosion resistance
- Operates using steam, air, nitrogen or other pressurized gases as the motive force
- Non-Electric – can be used in remote locations or NEMA 4, 7, 9 & hazardous areas

OPTIONS

- Cycle counter for measuring the amount of condensate flow through the pump.
- Insulation jackets are available to stop heat losses through the pump body.
- Sight glass for monitoring liquid level inside pump body.

NON-ELECTRIC CONDENSATE PUMPS

PMPSP "The Pit Boss"

Sump Drainer

Watson McDaniel reserves the right to change the designs and/or materials of its products without notice.
©2010 Watson McDaniel Company

PUMPS

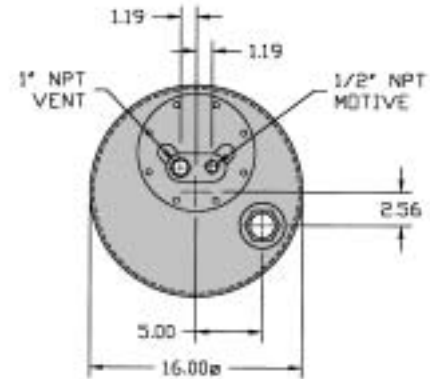

Model	PMPSP
Body	Carbon Steel
Cover	Ductile Iron
Check Valves	Stainless Steel
PMO Max. Operating Pressure	150 PSIG
TMO Max. Operating Temperature	366°F
PMA Max. Allowable Pressure	150 PSIG @ 650°F

Connection Sizes NPT	
Inlet	Outlet
1 1/2"	x 1 1/2"
2"	x 2"
3"	x 2"

TYPICAL APPLICATIONS

The PMPSP Sump Drainer uses the identical internal mechanism as the standard PMP models. The piping configuration is such that the liquid is discharged vertically upwards as opposed to horizontally out the side. This allows the unit to be easily positioned inside of a sump area. Condensate or water from the sump enters the tank through a stainless steel low resistance check valve.

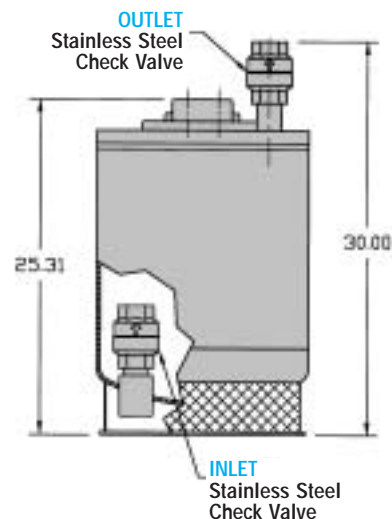

FEATURES

- Equipped with our Patented "Snap-Assure" Mechanism which extends the useful life of the pump
- Mechanism incorporates heat-treated stainless steel wear items
- All stainless steel internals for ultimate corrosion resistance
- Dual compression springs made from Inconel-X-750 for high-temperature corrosive service
- Operates using steam, air, nitrogen or other pressurized gases as the motive force
- Non-Electric – can be used in remote locations or NEMA 4, 7, 9 & hazardous areas
- Built-in strainer screen

NON-ELECTRIC CONDENSATE PUMPS

PMPSP

Sump Drainer

PUMPS

"The Pit Boss"

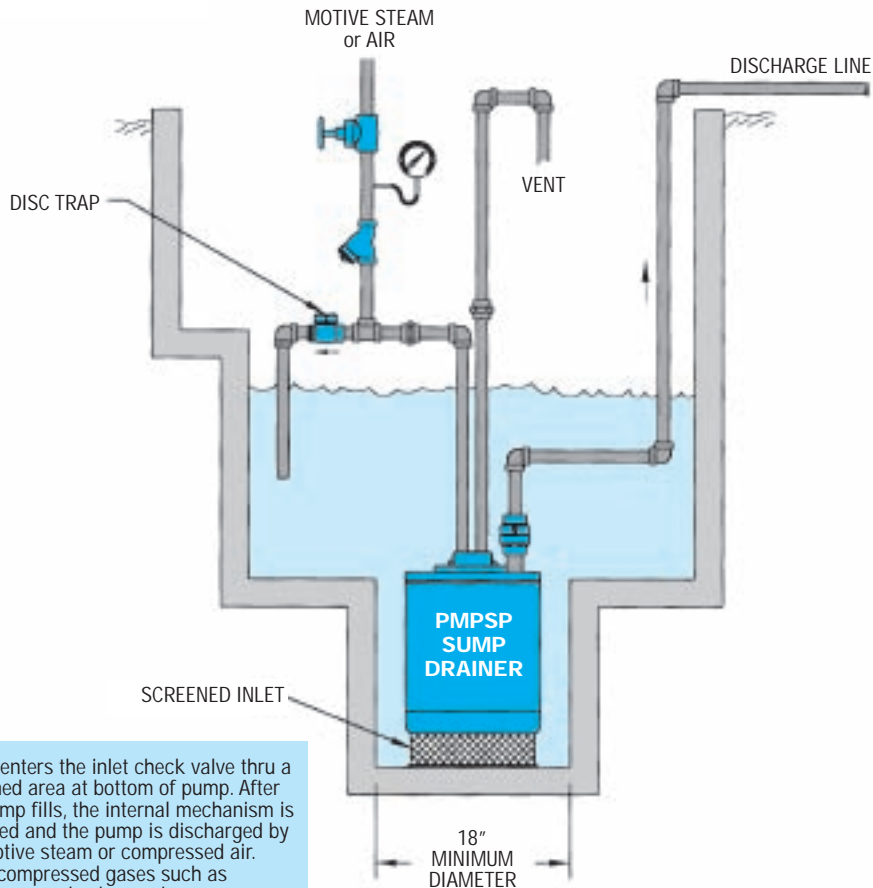

Water enters the inlet check valve thru a screened area at bottom of pump. After the pump fills, the internal mechanism is actuated and the pump is discharged by the motive steam or compressed air. Other compressed gases such as nitrogen can also be used.

CAPACITIES – Water (GPM) for 1 1/2" x 1 1/2" Size								
Motive Pressure (PSIG)	Capacity Correction Factors		Back Pressure (PSIG)					
	2" x 2"	3" x 2"	0	10	20	40	70	100
10	2.5	3	11.7					
20	1.8	2.4	12.5	9.2				
40	1.9	2.4	13.1	10.4	8.7			
70	1.7	2.4	12.9	11.0	9.4	7.1		
100	1.6	2	12.3	10.6	9.4	7.5	5.4	
125	1.6	2	11.6	10.1	9.0	7.5	5.6	4.3
150	1.6	2	10.7	9.5	8.8	7.2	5.7	4.5

Note: Capacities in above chart are for the 1-1/2" x 1-1/2" model. To determine capacities for the 2" x 2" & 3" x 2" models, multiply capacity in chart by appropriate correction factor.

Snap-Assure Patent No. 6572340

NON-ELECTRIC CONDENSATE PUMPS

Pumps with Receiver Tanks

Pressure Motive Pumps

PUMPS

Standard Skid Mounted Systems

FEATURES

- Easy to install with only four connections to be made in the field
- Dramatically reduces installation costs with all system elements pre-piped
- Utilizing Watson McDaniel's years of experience will ensure that vented receivers or pressurized reservoirs are properly sized for optimum system performance
- Watson McDaniel's fully-qualified fabrication facility is ASME code certified. Our engineers can design and build complete custom systems to meet all your requirements

TYPICAL OPTIONS

- Gauge glass assembly
- Cycle counter
- Insulation covers
- Motive steam drip trap
- Overflow pipe connection
- Pressure regulator for motive supply line

SIMPLEX SYSTEMS – Models PMPC & PMPF

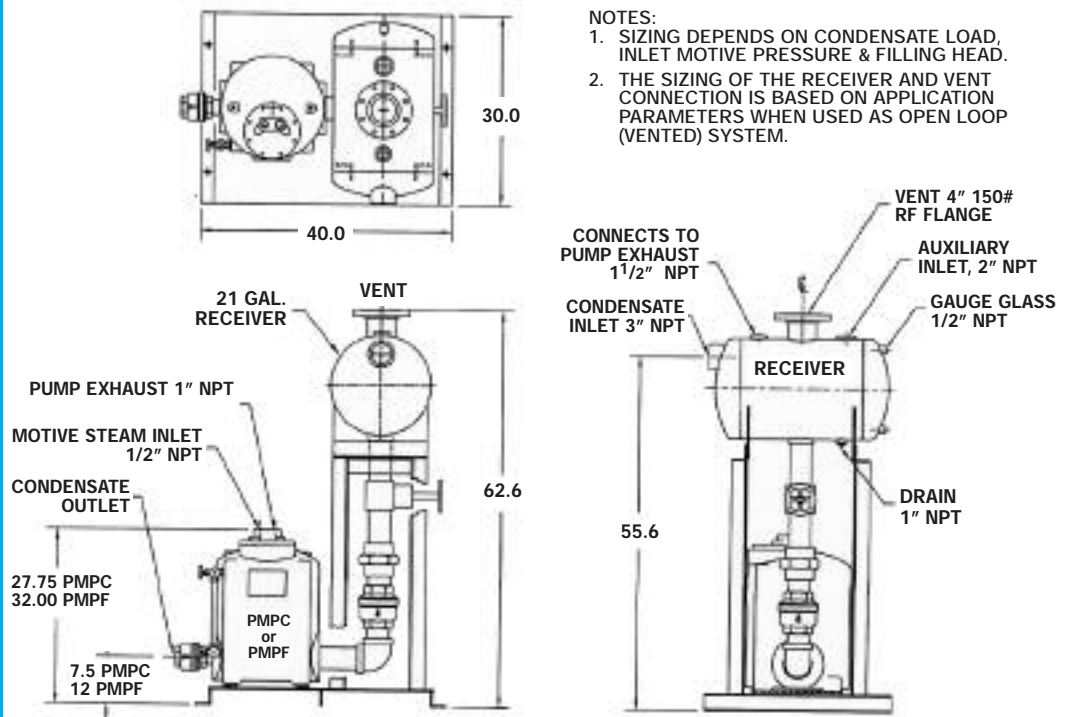

DUPLEX SYSTEMS – Models PMPC & PMPF

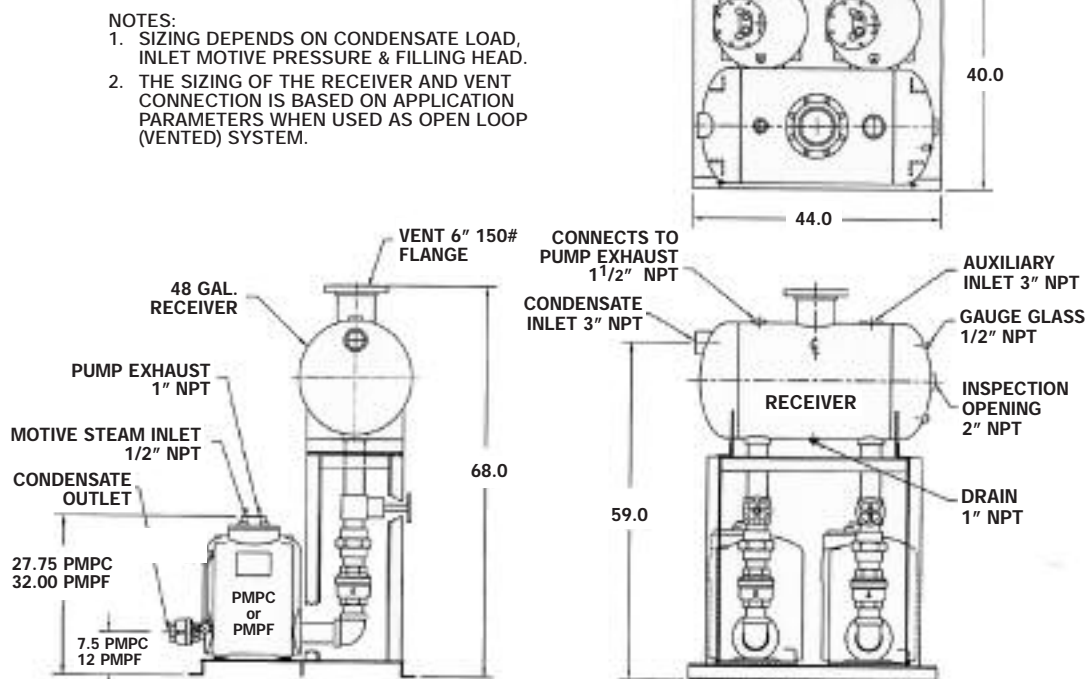

NON-ELECTRIC CONDENSATE PUMPS

Pumps with Receiver Tanks

Pressure Motive Pumps

TRIPLEX SYSTEMS – Models PMPC & PMPF

- NOTES:
1. SIZING DEPENDS ON CONDENSATE LOAD, INLET MOTIVE PRESSURE & FILLING HEAD.
 2. THE SIZING OF THE RECEIVER AND VENT CONNECTION IS BASED ON APPLICATION PARAMETERS WHEN USED AS OPEN LOOP (VENTED) SYSTEM.

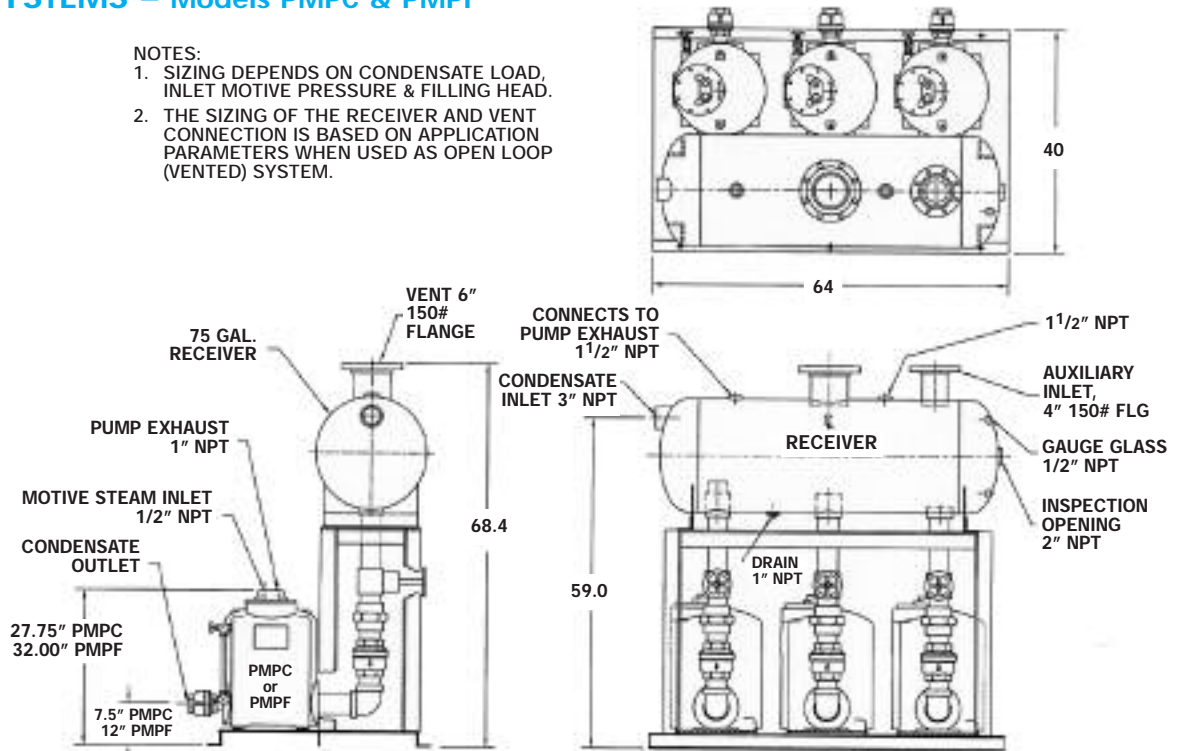

QUADRAPLEX SYSTEMS – Models PMPC & PMPF

- NOTES:
1. SIZING DEPENDS ON CONDENSATE LOAD, INLET MOTIVE PRESSURE & FILLING HEAD.
 2. THE SIZING OF THE RECEIVER AND VENT CONNECTION IS BASED ON APPLICATION PARAMETERS WHEN USED AS OPEN LOOP (VENTED) SYSTEM.

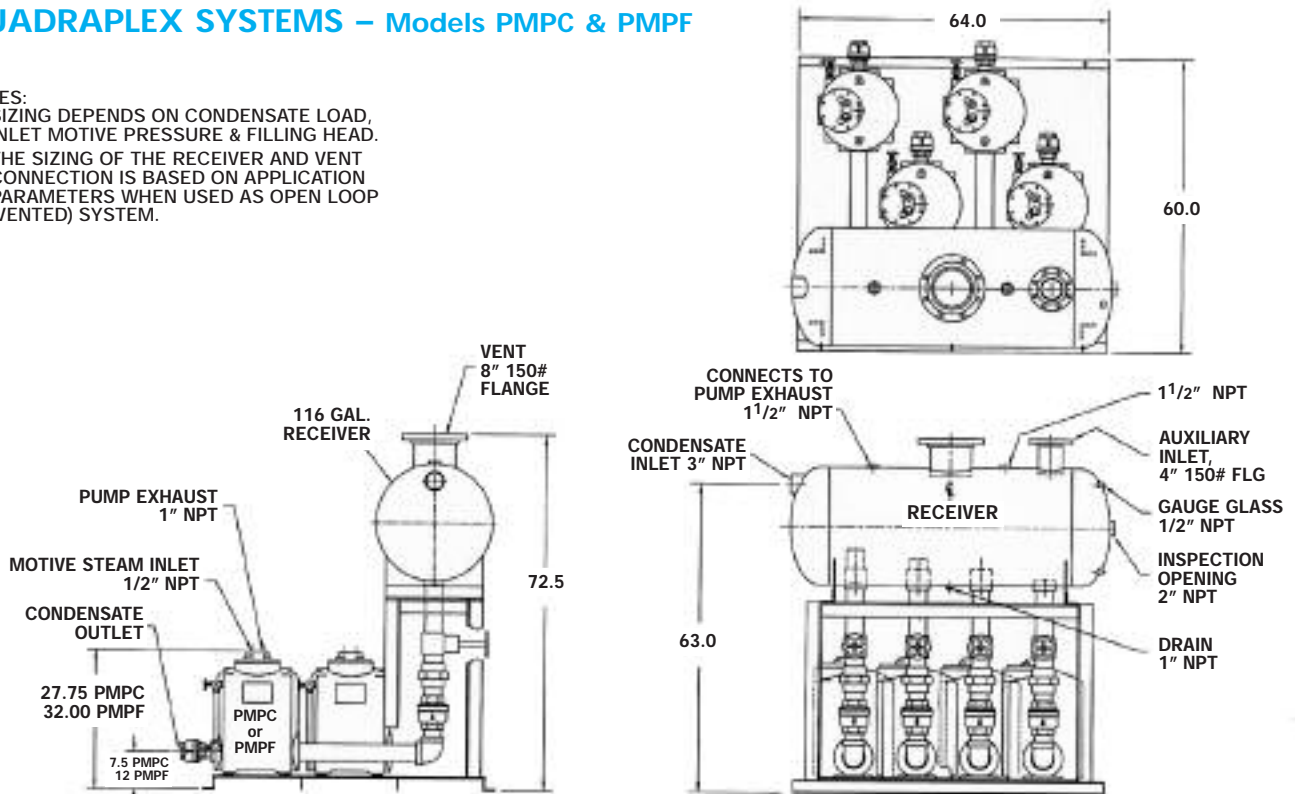

Pump & Trap Combinations

Why use a Pump-Trap?

A **Pump-Trap Combination** is used when draining condensate from a single piece of heat transfer equipment whose steam flow is being controlled with a modulating type valve. When a modulating valve controls the flow of steam to a heat exchanger, a stall condition can develop. Stall occurs when the modulating valve closes and steam pressure downstream of the valve is unable to push the condensate into the return line and it backs up into the heat exchanger. A Pump-Trap combination will eliminate this problem.

Pump-Traps with either **Internal** or **External** Steam Trap designs are available to suit individual application requirements.

Pump with Internal Steam Trap



PMPT

The Model PMPT low-profile pressure motive pump has an internal Steam Trap for applications requiring compact design due to spatial constraints. It is an excellent choice for drainage of various modulating process equipment.

Pump with External Steam Trap



WPT

The WPT Series are stand-alone pump units with an appropriately sized Steam Trap preassembled at the factory and mounted on a common base plate, allowing for simple installation. Pump-trap combos with an external trap are suitable when capacity requirements exceed internal steam trap designs. Available in several sizes and capacities.

The Pump-Trap Combination allows condensate discharge under all operating conditions of modulating equipment, including vacuum.

NON-ELECTRIC CONDENSATE PUMPS

PMPT & WPT

Pressure Motive Pump & Trap Combinations

Problem: Stalled Heat Exchanger

DESCRIPTION:

STALL CONDITION WITH MODULATED STEAM FLOW

When a modulating valve is used to control product temperature in heat transfer equipment, the valve will open and close as necessary to meet the variable demand of the system to maintain the product at constant temperature. Therefore, when maximum heating is required, the supply valve will be fully open to satisfy the high steam demand requirement. At this point, pressure is also being supplied at its highest level, which may be sufficient to overcome total system back pressure.

As the product temperature is satisfied, demand decreases and the valve correspondingly begins to close, reducing pressure differential. If demand is satisfied, the valve modulates to its fully closed position. Inlet supply pressure will eventually fall below system back pressure, resulting in system stall. This leads to poor heat transfer and water hammer as condensate backs up in the heat transfer equipment.

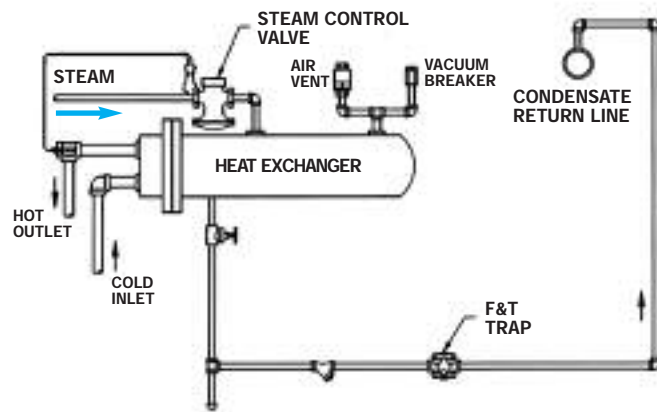

Heat Exchanger System without PMP

Solution: Use PMP & Steam Trap Combination

DESCRIPTION:

USE A PRESSURE MOTIVE PUMP AND STEAM TRAP COMBINATION

(Available in INTERNAL and EXTERNAL Steam Trap designs)

When the supply valve is fully open and inlet pressure exceeds back pressure, condensate forming in the heat transfer equipment will be pushed through the pump and steam trap into the condensate return line. As the supply valve begins to close and the back pressure exceeds inlet pressure, any condensate forming inside the heat transfer equipment will drain by gravity into the pump tank. The condensate will accumulate in the pump tank until the float mechanism reaches its trip point. The "tripping" of the mechanism opens the motive valve to allow high pressure steam into the tank to drive the condensate from the tank to the condensate return line.

Note: A larger steam trap than normally required to drain the heat transfer equipment must be used to handle the high instantaneous discharge rate of the pump. See additional information in this catalog for sizing guidelines.

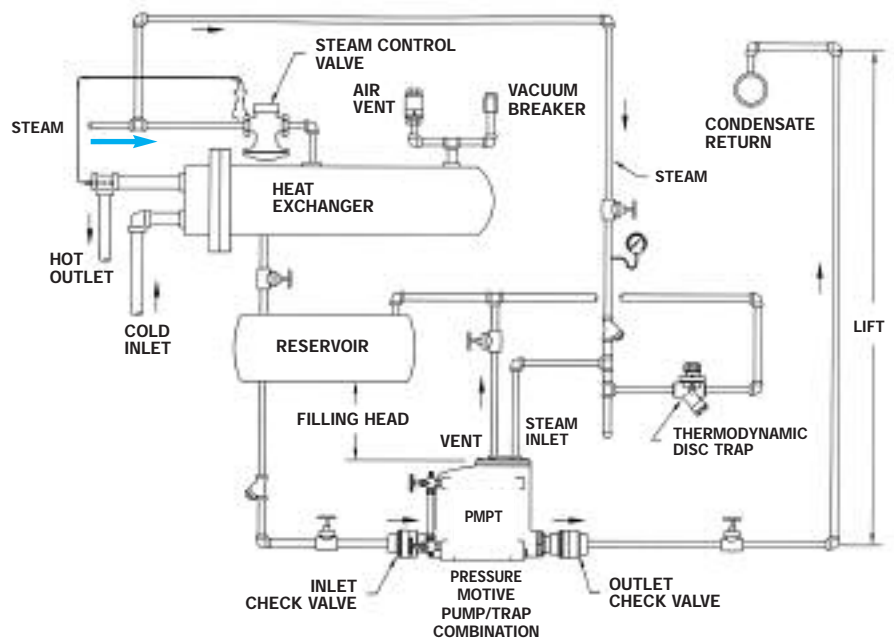

Heat Exchanger System with PMP & Internal Trap (PMPT) (Closed Loop System)

NON-ELECTRIC CONDENSATE PUMPS

PMPT

Watson McDaniel reserves the right to change the designs and/or materials of its products without notice.
©2010 Watson McDaniel Company

Pressure Motive Pump & Trap Combination (Internal Trap)

PUMPS

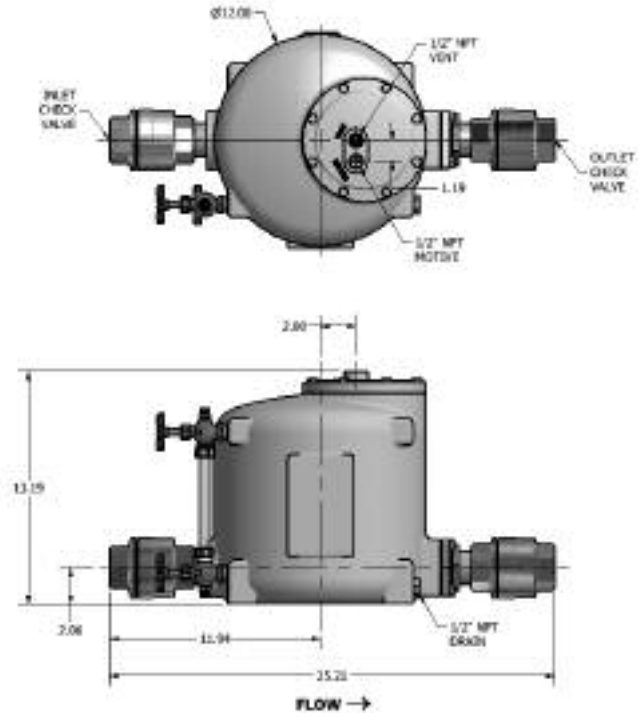

Model	PMPT
Body	Ductile Iron
Cover	Stainless Steel
Sizes	1", 1 1/2"
Check Valves	Stainless Steel
PMO Max. Operating Pressure	125 PSIG
TMO Max. Operating Temperature	366°F
PMA Max. Allowable Pressure	150 PSIG @ 450°F

TYPICAL APPLICATIONS

The Model PMPT low-profile pressure motive pump has an internal Steam Trap for applications requiring compact design due to spatial constraints. It is an excellent choice for drainage of various modulating process equipment.

The PMPT allows condensate discharge under all operating conditions of modulating equipment, including vacuum.

FEATURES

- Compact, low-profile design allows for drainage of equipment positioned close to the floor
- The PMPT provides provides condensate drainage for modulating equipment, preventing inefficient and dangerous system stall
- Equipped with our proven, Patented "Snap-Assure" mechanism which extends the useful life of the pump
- Internal mechanism can be removed from the top of the pump while pump remains piped in line
- Mechanism incorporates heat-treated stainless steel wear items
- Dual compression springs made from Inconel-X-750 for high-temperature, corrosive service

MATERIALS

Body	Ductile Iron SA-395
Cover	Stainless Steel CF8
Cover Gasket	Garlock
Cover Bolts	Steel
Inlet Valve	Hardened Stainless Steel 40 Rc
Vent Valve	Hardened Stainless Steel 40 Rc
Ball Float	300 Stainless Steel
Check Valves	Stainless Steel 316SS CF3
Springs	Inconel-X-750
Other Internal Components	Stainless Steel

OPTIONS

- Horizontal pipe reservoir (recommended)
- Motive and vent piping
- Motive piping components such as steam trap, strainer and regulator
- Packaged systems available with reservoir, base and skid
- ASME Code Stamp available upon request

Patent Pending

NON-ELECTRIC CONDENSATE PUMPS

PMPT

Pressure Motive Pump & Trap Combination (Internal Trap)

PUMPS

Capacity Operating in Pump Mode

CAPACITIES – Condensate (lbs/hr) Using steam as a motive pressure			
Motive Pressure (PSIG)	Total Back Pressure (PSIG)	Check Valve Size	
		1" x 1" 6" Head	1 1/2" x 1 1/2" 6" Head
5	2	150	258
10	5	302	523
10	2	409	704
25	15	791	1380
25	10	1020	1780
25	5	1224	2110
50	40	839	1470
50	25	1012	1770
50	10	1318	2280
75	60	810	1420
75	40	1122	1970
75	15	1241	2150
100	80	490	859
100	60	969	1700
100	40	1209	2100
100	15	1318	2260
125	115	146	256
125	100	371	649
125	80	634	1110
125	60	961	1680
125	40	1054	1830
125	15	1046	1780

Capacity Operating in Trap Mode

TRAP CAPACITIES	
Differential Pressure (PSI)	Capacity - Condensate (lbs/hr)
5	3470
10	4126
20	4907
30	5430
40	5835
50	6170
65	6588
75	6828
100	7337
125	7758

NON-ELECTRIC CONDENSATE PUMPS

WPT Series

Pressure Motive Pump & Trap
Combination (External Trap)

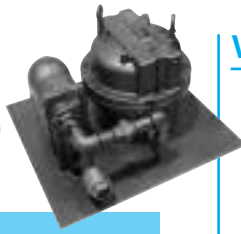

PUMPS

WPT Series Pump-Trap Combinations simplify Selection & Installation of Pressure Motive Pumps

- 5 size ranges available
- Up to 13,000 lbs/hr of condensate load

TYPICAL APPLICATIONS

The Watson McDaniel WPT Pump-Trap Combinations are excellent for draining heat exchangers or other equipment that is being fed by a temperature regulator or a temperature control valve. In these applications, the steam pressure in the heat exchanger may not be sufficient to overcome the back pressure in the condensate return line. When this condition occurs, the pressure powered pump takes over and uses high pressure steam supplied to the pump to discharge the condensate through the trap. When sufficient pressure does exist, the system functions like a standard steam trap.

PUMP-TRAP FEATURES

- Pump and Steam Trap are pre-mounted together on a single base for easy installation
- Engineering and selection is simplified

NOTE: Reservoir - The majority of Pump-Trap Combination applications require a reservoir above the pump to accommodate any condensate back-up during the discharge cycle of the pump. Consult Reservoir Sizing Guidelines or contact factory for additional information.

WPT1 - 1" x 1" (PMPM with 1 1/2" FTE-200)

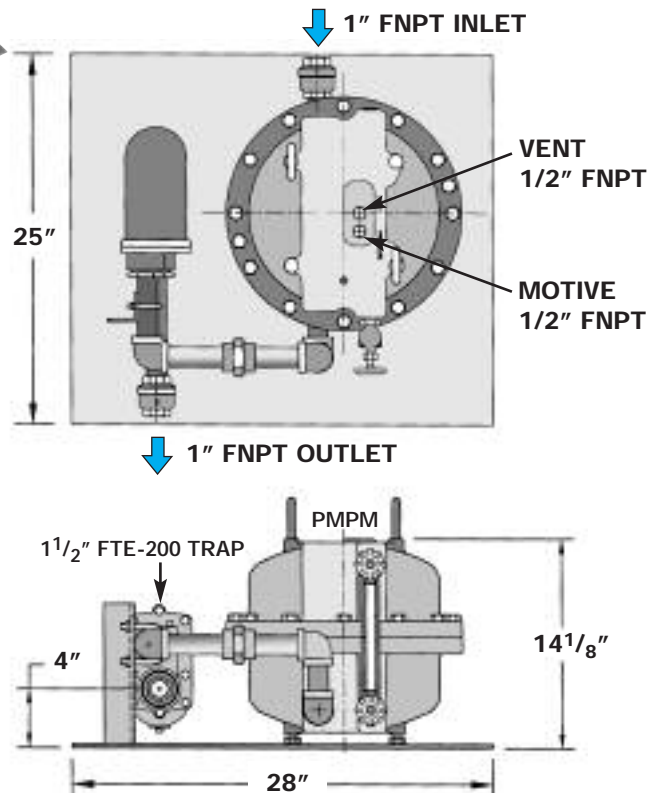

CAPACITIES – Condensate (lbs/hr) Using steam as a motive pressure

Motive Pressure (PSIG)	Total Back Pressure (PSIG)	WPT1	WPT2	WPT3	WPT4	WPT5
		1" x 1" 6" Head	1 1/4" x 1 1/4" 6" Head	1 1/2" x 1 1/2" 12" Head	2" x 2" 12" Head	3" x 2" 12" Head
5	2	185	335	1310	2320	4270
10	5	370	648	1760	3740	6230
10	2	502	898	2350	5640	9450
25	15	958	1590	2700	4690	7230
25	10	1240	2090	3020	5970	9370
25	5	1490	2570	3780	6850	11400
50	40	1010	1610	2090	3410	5040
50	25	1220	1970	3620	6650	10200
50	10	1600	2680	4080	7140	11500
75	60	993	1560	2250	3730	5660
75	40	1380	2190	3470	6010	8770
75	15	1550	2580	4390	7920	12400
100	80	612	951	2620	4390	6140
100	60	1210	1900	3390	5780	8120
100	40	1540	2440	4310	6940	10000
100	15	1720	2840	4620	8000	12300
125	115	195	301	2280	3490	4440
125	100	488	753	2880	4420	5720
125	80	836	1300	3520	5700	7630
125	60	1280	2000	4110	6880	9390
125	40	1420	2270	4910	7800	11100
125	15	1470	2440	5120	8420	12900
150	120	588	904	2560	3640	5100
150	100	977	1510	3020	4610	6270
150	80	1060	1640	3630	5780	8140
150	60	1340	2100	4230	6910	9920
150	40	1420	2260	4830	7930	11700
150	15	1450	2390	5230	8590	13300

Consult factory for motive pressures up to 200 PSIG

NON-ELECTRIC CONDENSATE PUMPS

WPT2 - 1 1/4" x 1 1/4" (PMPM with 2" FTE-200)

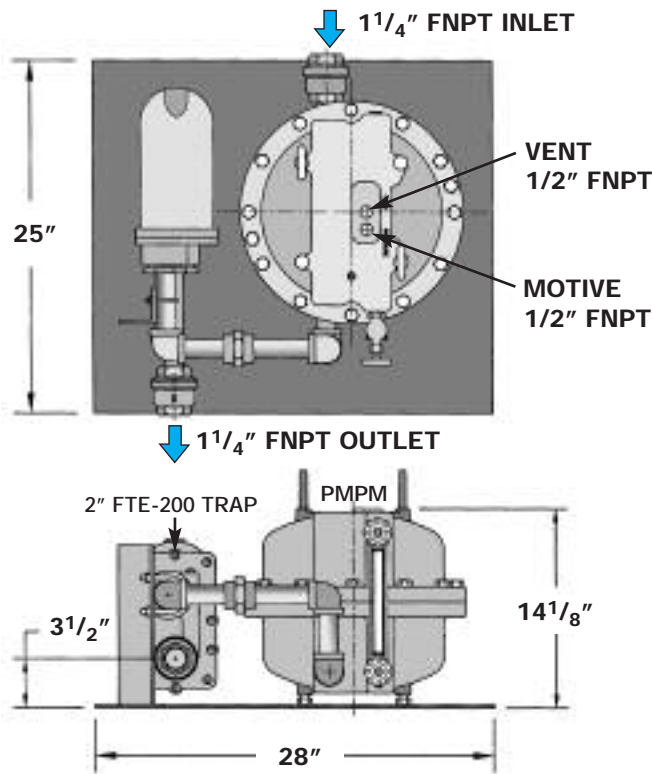

WPT3 - 1 1/2" x 1 1/2" (PMPLS with 2" FTE-200)

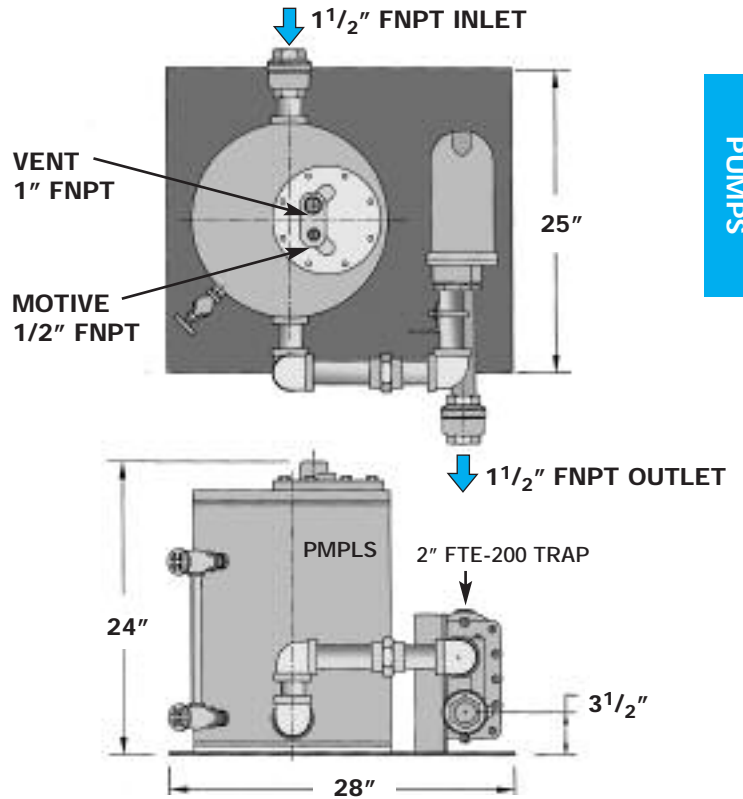

WPT4 - 2" x 2" (PMPC with 2" FTE-200)

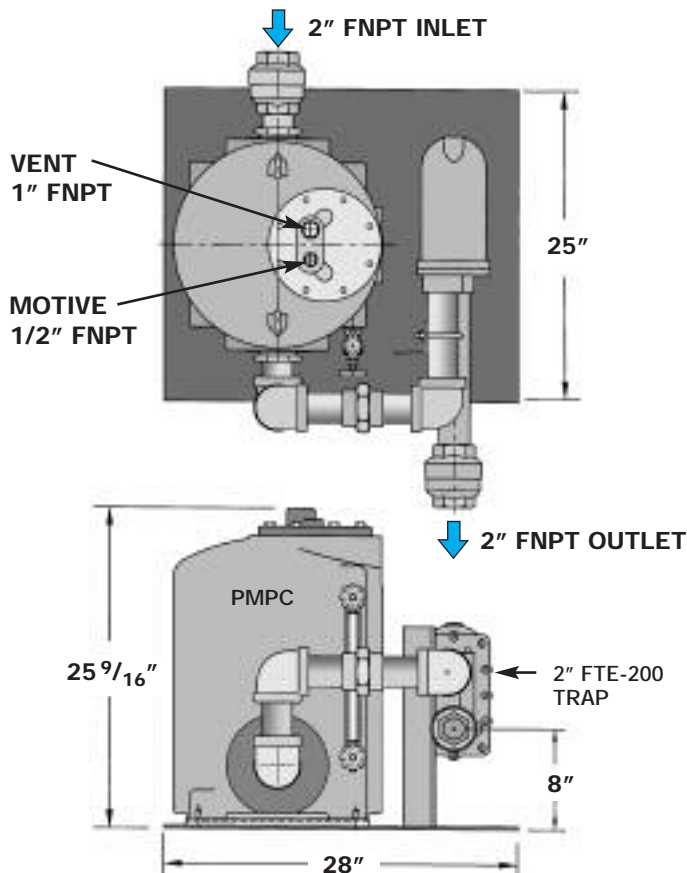

WPT5 - 3" x 2" (PMPC with 2 1/2" FTE-200)

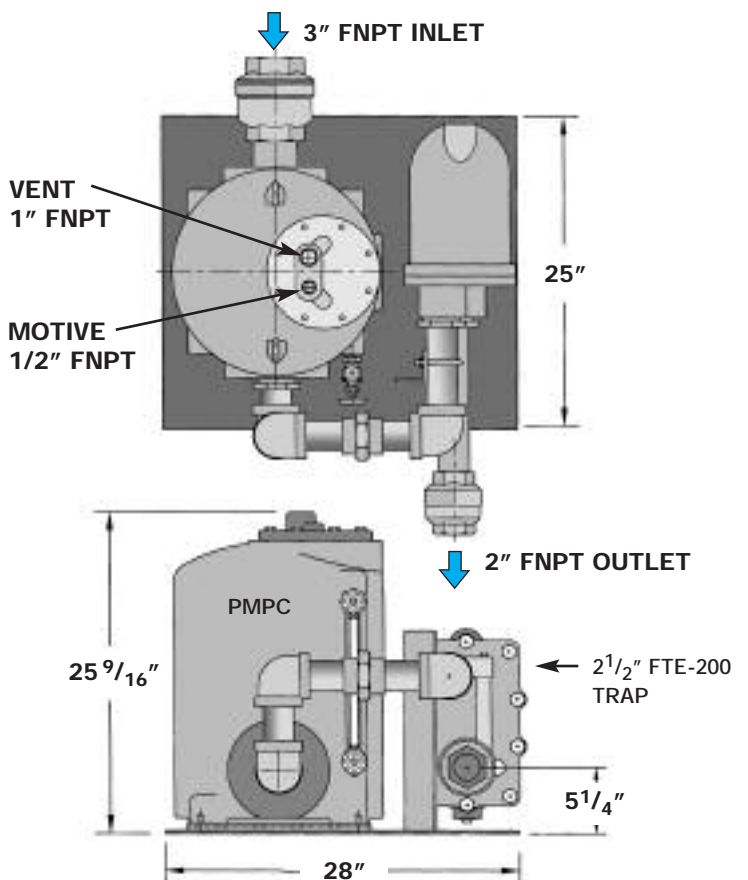

PUMPS

NON-ELECTRIC CONDENSATE PUMPS

Accessories & Options

Watson McDaniel reserves the right to change the designs and/or materials of its products without notice.
©2010 Watson McDaniel Company

Pressure Motive Pumps

PUMPS

Receiver Tanks

Four standard condensate receiver sizes are available for our Pressure Motive Pump Systems: 21, 48, 75 and 116 gallons. Custom Receiver fabrication is available with our **ASME** certified fabrication facility.

Gauge Glass

Pump Tanks are available with **gauge glass** to show condensate level inside the tank. (bronze or stainless steel retainer)

Cycle Counter

- The **cycle counter option** allows you to calculate and measure condensate flow through the pump on vented systems. This also gives an indication when maintenance and repairs to your mechanism may be required.
- Proper selection of the appropriate cycle counter is required: consult factory.
- The low-differential pressure cycle counter must be selected for applications where total pump back pressure is below 15 PSIG.
- Special cycle counter required when used on Closed Loop Systems.

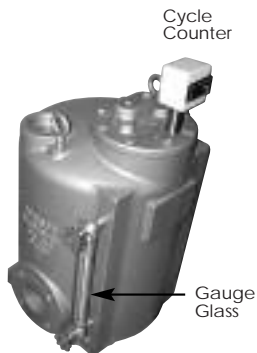

Pre-Piped PRV & Drip Leg

A fully-assembled Pre-piped PRV, Drip Leg, or PRV and Drip Leg Assembly **guarantees proper installation** of your PMP System. It assures that your skid package performs to optimum levels.

Vertical Discharge Pump

Vertical Discharge Pump with **"T-Bone"** connection allows inlet and outlet condensate hook-ups to be made above the pump. This is an advantage when space is limited around the base of the pump due to equipment or piping obstructions.

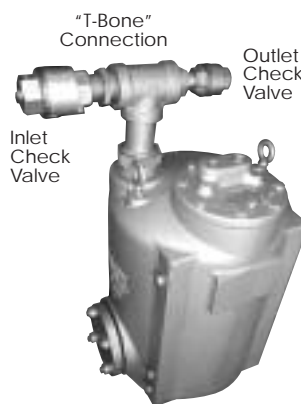

Product Description	Model Code
GAUGE GLASS:	
Standard Bronze	
for PMPC, PMPF, PMPLS, 21 Gallon Receiver	Gauge Glass 1
for PMPT	Gauge Glass PMPT
for PMPM Mini Pump (extremely low profile)	Gauge Glass PMPM
for 48 Gallon Receiver	Gauge Glass 1
for 75 Gallon Receiver	Gauge Glass 1
for 116 Gallon Receiver	Gauge Glass 1
Stainless Steel	
for PMPSS	Gauge Glass SS
Following Options are available for gauge glasses. Contact factory.	
Auto Drain (self-drain) Stainless Steel Armored	Gauge Glass 1A
Reflex Gauge for PMPC, PMPF, PMPLS, 21 Gallon Receiver	Gauge Glass - 1HP
CYCLE COUNTER:	
Digital Cycle Counter (fits all PMPs)	Specify open or closed system
Low Pressure Cycle Counter (fits all PMPs)	
ASME Code Stamp:	
for PMPC, PMPT & PMPBP Pump Tank	(Contact Factory)
(Standard on 21, 48, 75, 116 Gallon Receivers and PMPF, PMPLS, PMPSS pump tanks)	
INSULATION JACKET:	
for PMPC Ductile Iron Pump	INSUL-CRV-PMPC
for PMPF Fabricated Steel Pump	INSUL-CRV-PMPF
for PMPLS Low Profile Pump	INSUL-CRV-PMPLS
for PMPBP High Capacity Pump	INSUL-CRV-PMPBP
for PMPT Pump-Trap	INSUL-CRV-PMPT
for PMPM Mini Pump (extremely low profile)	INSUL-CRV-PMPM
for 21 Gallon Receiver	INSUL-CRV-21
for 48 Gallon Receiver	INSUL-CRV-48
for 75 Gallon Receiver	INSUL-CRV-75
for 116 Gallon Receiver	INSUL-CRV-116

NON-ELECTRIC CONDENSATE PUMPS

Accessories & Options

Pressure Motive Pumps



Insulation Jacket

Insulation Jackets **conserve energy** by reducing heat loss. They also improve safety by protecting personnel from hot surfaces. Jackets have velcro closures for easy installation or removal. Fits tightly around pump tanks and receivers.

Patented "Snap-Assure" Feature

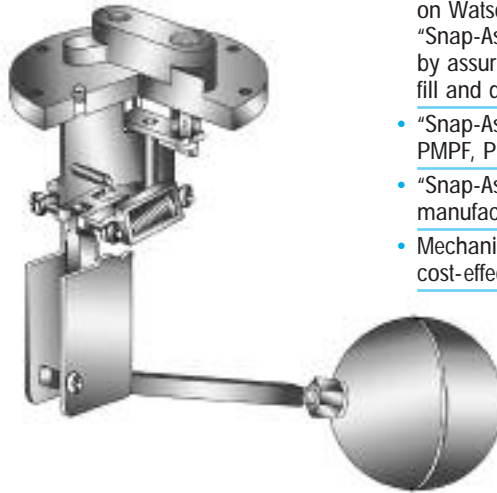

- Patented "Snap-Assure" feature is found only on Watson McDaniel's pump mechanisms. "Snap-Assure" extends the useful life of the pump by assuring the internal mechanism toggles at every fill and discharge.
- "Snap-Assure" is supplied standard in Models PMPC, PMPF, PMPT, PMPLS, PMPSS & PMPSP.
- "Snap-Assure" mechanisms will also fit other manufacturers' pump tanks.
- Mechanisms are simple and easy to replace, and are a cost-effective way to make your pump as good as new.

Snap-Assure Patent No. 6572340

Product Description	Model Code
PRE-PIPED ACCESSORIES:	
Pre-piped Pressure Regulating Valve (PRV) for motive steam or air	PRV1
Pre-piped Drip Leg Station with Steam Trap	PRV2
Pre-piped Drip Leg Station with Steam Trap and PRV	PRV3
Pre-piped Exhaust Line	PRV4
MECHANISMS:	
New Mechanism Assembly with Cover for PMPF	900-03
for PMPC, PMPLS	910-03
for PMPBP	900-02
for PMPT	921-03
for PMPM (cover not required)	911-03
REBUILT MECHANISMS: *	
for PMPF	900-03R
for PMPC, PMPLS	910-03R
for PMPT	921-03R
CHECK VALVES:	
Stainless Steel: 1/2" - 3" NPT	See WSSCV Page

* Note for Rebuilt Mechanisms:

The exchange program is for mechanisms with two years of service or less. The old mechanism must be returned along with the order for the rebuilt mechanism. Orders without old mechanisms will be invoiced at the new mechanism price.

NON-ELECTRIC CONDENSATE PUMPS

Sizing & Selection

Pressure Motive Pumps - Capacities

Watson McDaniel reserves the right to change the designs and/or materials of its products without notice.
©2010 Watson McDaniel Company

PUMPS

CAPACITIES – Condensate (lbs/hr) Using steam as a motive pressure												
Motive Pressure (PSIG)	Total Back Pressure (PSIG)	PMPLS 1" X 1" 6" Head	PMPC, PMPF, PMPSS*									PMPBP 4" x 4" 24" Head
			1 1/2" X 1" 12" Head	1 1/2" X 1 1/2" 12" Head	2" X 1" 12" Head	2" X 1 1/2" 12" Head	2" X 2" 12" Head	3" x 2" 12" Head	3" x 2" Duplex	3" x 2" Triplex	3" x 2" Quadraplex	
5	2	1,760	1,860	1,920	2,860	3,180	3,540	5,000	10,000	15,000	20,000	16,600
10	5	1,870	2,200	2,450	4,350	4,840	5,380	7,210	14,420	21,630	28,840	19,000
10	2	2,200	3,030	3,370	6,880	7,650	8,500	11,110	22,220	33,330	44,440	22,600
25	15	1,650	3,130	3,480	4,990	5,550	6,170	8,230	16,460	24,690	32,920	33,200
25	10	1,980	3,600	3,990	6,560	7,290	8,100	10,780	21,560	32,340	43,120	40,300
25	5	2,300	4,700	5,200	7,970	8,860	9,850	13,350	26,700	40,050	53,400	46,200
50	40	1,650	2,280	2,530	3,370	3,750	4,170	5,670	11,340	17,010	22,680	33,300
50	25	1,980	4,050	4,500	6,800	7,560	8,440	11,550	23,100	34,650	46,200	40,100
50	10	2,300	4,700	5,240	7,970	8,860	9,850	13,440	26,880	40,320	53,760	47,000
75	60	1,540	2,400	2,660	3,600	4,000	4,440	6,340	12,680	19,020	25,360	32,900
75	40	1,980	3,780	4,190	5,920	6,580	7,320	9,870	19,740	29,610	39,480	39,400
75	15	2,420	5,130	5,700	8,580	9,540	10,600	14,330	28,660	42,990	57,320	47,200
100	80	1,650	2,750	3,060	4,160	4,630	5,150	6,860	13,720	20,580	27,440	27,200
100	60	1,870	3,600	4,000	5,560	6,180	6,870	9,100	18,200	27,300	36,400	35,100
100	40	2,090	4,700	5,210	6,880	7,650	8,500	11,270	22,540	33,810	45,080	42,100
100	15	2,420	5,400	6,010	8,740	9,720	10,800	14,330	28,660	42,990	57,320	48,000
125	115	1,430	2,380	2,640	3,270	3,640	4,050	4,960	9,920	14,880	19,840	19,500
125	100	1,540	2,980	3,330	4,140	4,600	5,130	6,390	12,780	19,170	25,560	25,300
125	80	1,760	3,430	4,100	5,400	6,000	6,670	8,540	17,080	25,620	34,160	32,200
125	60	1,980	4,170	4,850	6,600	7,340	8,160	10,530	21,060	31,590	42,120	38,500
125	40	2,200	5,100	5,950	7,760	8,630	9,590	12,500	25,000	37,500	50,000	44,000
125	15	2,420	5,850	6,660	9,240	10,270	11,420	15,100	30,200	45,300	60,400	49,200
150	120	1,590	2,650	2,940	3,400	3,780	4,200	5,690	11,380	17,070	22,760	21,600
150	100	1,640	3,150	3,490	4,320	4,800	5,350	7,000	14,000	21,000	28,000	29,000
150	80	1,860	3,800	4,230	5,490	6,100	6,770	9,100	18,200	27,300	36,400	34,500
150	60	2,080	4,500	5,000	6,660	7,400	8,240	11,120	22,240	33,360	44,480	40,300
150	40	2,300	5,290	5,870	7,920	8,800	9,780	13,220	26,440	39,660	52,880	44,700
150	15	2,520	6,100	6,820	9,450	10,500	11,680	15,500	31,000	46,500	62,000	49,500
175	140	-	2,600	2,900	3,800	4,200	4,650	6,200	12,400	18,600	24,800	-
175	120	-	3,100	3,400	4,400	4,850	5,400	7,200	14,400	21,600	28,800	-
175	100	-	3,600	4,000	5,100	5,700	6,300	8,400	16,800	25,200	33,600	-
175	60	-	4,850	5,400	6,900	7,700	8,550	11,400	22,800	34,200	45,600	-
175	40	-	6,200	6,900	8,900	9,850	10,950	14,600	29,200	43,800	58,400	-
175	15	-	7,500	8,350	10,600	11,900	13,200	17,600	35,200	52,800	70,400	-
200	160	-	2,400	2,700	3,500	3,800	4,300	5,700	11,400	17,100	22,800	-
200	140	-	3,100	3,400	4,400	4,900	5,400	7,200	14,400	21,600	28,800	-
200	100	-	4,200	4,650	5,950	6,600	7,350	9,800	19,600	29,400	39,200	-
200	80	-	4,700	5,250	6,750	7,500	8,300	11,100	22,200	33,300	44,400	-
200	40	-	6,800	7,550	9,700	10,800	11,950	15,950	31,900	47,850	63,800	-
200	15	-	8,400	9,350	12,000	13,300	14,800	19,700	39,400	59,100	78,800	-

* PMPSS is rated to only 150 PSIG.

Capacity Correction Factors for Alternate Filling Heads							
Pump Inlet Size	Filling Head						
	6"	12"	18"	24"	36"	48"	60"
1"	1.00	1.10	1.20	1.30	1.50		
1 1/2"	0.70	1.00	1.10	1.20	1.35		
2"	0.70	1.00	1.10	1.20	1.35		
3"	0.84	1.00	1.04	1.08	1.20		
4"			0.80	1.00	1.10	1.15	1.20

NOTE: When the filling head differs from the standard filling height, the capacity of the pressure power pumps are either increased or decreased. For example, a pump with a 3" inlet that has a filling head of 36" as opposed to a standard filling head of 12", will have a capacity increase of 20%. Multiply the value found in the Capacity Table above by 1.2.

Capacity Correction Factors for Gas as Motive Pressure									
Pump Inlet Size	% Back Pressure relative to Motive Pressure								
	10%	20%	30%	40%	50%	60%	70%	80%	90%
1"	1.00	1.13	1.16	1.20	1.25	1.30	1.35	1.40	1.45
1 1/2"	1.04	1.06	1.08	1.10	1.12	1.15	1.18	1.23	1.28
2"	1.04	1.06	1.08	1.10	1.12	1.15	1.18	1.23	1.28
3"	1.04	1.06	1.08	1.10	1.12	1.15	1.18	1.23	1.28
4"	No Capacity Change								

Note: For slow-fill or low specific gravity applications, consult factory.

NON-ELECTRIC CONDENSATE PUMPS

Sizing & Selection

Pressure Motive Pumps - Capacities

Model PMPM - Pressure Motive Pump

CAPACITIES – Condensate (lbs/hr)					
Motive Pressure (PSIG)	Back Pressure (PSIG)	6" Filling Head			
		Steam Motive		Air Motive	
		1"	1 1/4"	1"	1 1/4"
25	15	1200	1800	1720	2580
25	5	1970	2955	2265	3398
50	40	1200	1800	1640	2460
50	25	1480	2220	1980	2970
50	15	1860	2790	2220	3330
50	5	2240	3360	2485	3728
75	60	1160	1740	1935	2903
75	40	1640	2460	2185	3278
75	25	1960	2960	2340	3510
100	60	1415	2122	2020	3030
100	40	1825	2732	2280	3420
100	25	1985	2977	2420	3630
100	15	2175	3262	2455	3683
150	100	1120	1680	1456	2184
150	80	1220	1830	1525	2288
150	60	1570	2355	1885	2828

WPT Series - Pump-Trap Combinations

CAPACITIES – Condensate (lbs/hr); using steam as a motive pressure						
Motive Pressure (PSIG)	Total Back Pressure (PSIG)	WPT1	WPT2	WPT3	WPT4	WPT5
		1" x 1" 6" Head	1 1/4" x 1 1/4" 6" Head	1 1/2" x 1 1/2" 12" Head	2" x 2" 12" Head	3" x 2" 12" Head
5	2	185	335	1310	2320	4270
10	5	370	648	1760	3740	6230
10	2	502	898	2350	5640	9450
25	15	958	1590	2700	4690	7230
25	10	1240	2090	3020	5970	9370
25	5	1490	2570	3780	6850	11400
50	40	1010	1610	2090	3410	5040
50	25	1220	1970	3620	6650	10200
50	10	1600	2680	4080	7140	11500
75	60	993	1560	2250	3730	5660
75	40	1380	2190	3470	6010	8770
75	15	1550	2580	4390	7920	12400
100	80	612	951	2620	4390	6140
100	60	1210	1900	3390	5780	8120
100	40	1540	2440	4310	6940	10000
100	15	1720	2840	4620	8000	12300
125	115	195	301	2280	3490	4440
125	100	488	753	2880	4420	5720
125	80	836	1300	3520	5700	7630
125	60	1280	2000	4110	6880	9390
125	40	1420	2270	4910	7800	11100
125	15	1470	2440	5120	8420	12900
150	120	588	904	2560	3640	5100
150	100	977	1510	3020	4610	6270
150	80	1060	1640	3630	5780	8140
150	60	1340	2100	4230	6910	9920
150	40	1420	2260	4830	7930	11700
150	15	1450	2390	5230	8590	13300

NON-ELECTRIC CONDENSATE PUMPS

Sizing & Selection

Watson McDaniel reserves the right to change the designs and/or materials of its products without notice.
©2010 Watson McDaniel Company

Pressure Motive Pumps

PUMPS

Sizing & Selection

The capacity of a Pressure Motive Pump is determined by the Model and the size of the inlet and outlet check valves. The larger the check valves used, the more capacity the pump can handle. For example: The 3" x 2" pump has a 3" inlet check valve and a 2" outlet check valve.

STAND-ALONE PUMPS are furnished with pump tank, check valves and internal pumping mechanism.

PUMPS WITH RECEIVER TANKS include the stand-alone pump(s), check valves, and receiver tank mounted together on a frame. These are available in Simplex, Duplex, Triplex and Quadraplex systems.

When sizing and selecting a Pressure Motive Pump, five system conditions are required:
(See Diagram on following page)

- 1 Condensate Load
- 2 Condensate Pressure
- 3 Motive Steam, Air or other Gas Pressure available for operating the pump
- 4 Available Filling Head between the bottom of the receiver tank and the top of the pump tank
- 5 Total System Back Pressure (BP)
 - a) Condensate Return Line Pressure (5A)
 - b) Vertical Height condensate must be lifted (5B)

SAMPLE SYSTEM CONDITIONS

1 Condensate Load	8,000 lbs/hr
2 Condensate Pressure	50 PSIG
3 Motive Steam Pressure	Steam @ 100 PSIG
4 Filling Head	12"
5 Total Back Pressure = a + b	
a) Line Pressure	30 PSIG
b) Vertical Lift	23 ft. (convert to PSIG)

Calculation of Total Back Pressure:

To find the pressure required to lift condensate in PSIG, multiply the lift in feet by 0.433.

Pressure required to lift Condensate (0.433 x 23 ft.)	10 PSIG
Pressure in Return Pipe	+ 30 PSIG
Total Back Pressure	= 40 PSIG

Open Loop with Vented Receiver

(When draining condensate from multiple sources)

For PMP Sizing:

Consult PMP Sizing Capacity Chart using 100 PSIG inlet pressure and 40 PSIG back pressure. A 2" x 2" pump has a capacity of 8,500 lbs/hr and is an appropriate selection. Pump choices are models PMPC, PMPF and PMPSS.

For Receiver and Vent Connection Sizing:

Refer to the Vented Receiver Sizing Chart for guidelines on how to calculate the flash steam generated and use this value to size the receiver and vent connection.

Closed Loop with Pressurized Reservoir

(When draining condensate from a single piece of heat transfer equipment)

For PMP and Trap Sizing:

Reference PMPT and WPT Pump-Trap Combination Capacity Charts for an estimation of the unit required. Contact factory for more accurate sizing.

For Reservoir Pipe Sizing

Refer to the Reservoir Pipe Length Chart for guidelines on determining the appropriate diameter and length of pipe required for condensate back-up.

HOW TO ORDER

SPECIFY:	EXAMPLE:
1) Model or Pumps	PMPC
2) Size of Pump(s)	2" x 2"
3) Stand-alone Pump or Pump with Receiver Tank	Simplex or Duplex
<i>(Note: Size of Receiver Tank must be specified when ordering Pump with Receiver Tank)</i>	
4) Options	Gauge glass
5) When ordering a Customized Skid System, please confirm and specify Receiver size.	

NON-ELECTRIC CONDENSATE PUMPS

Sizing & Selection

Pressure Motive Pumps

PMP Sizing & Selection

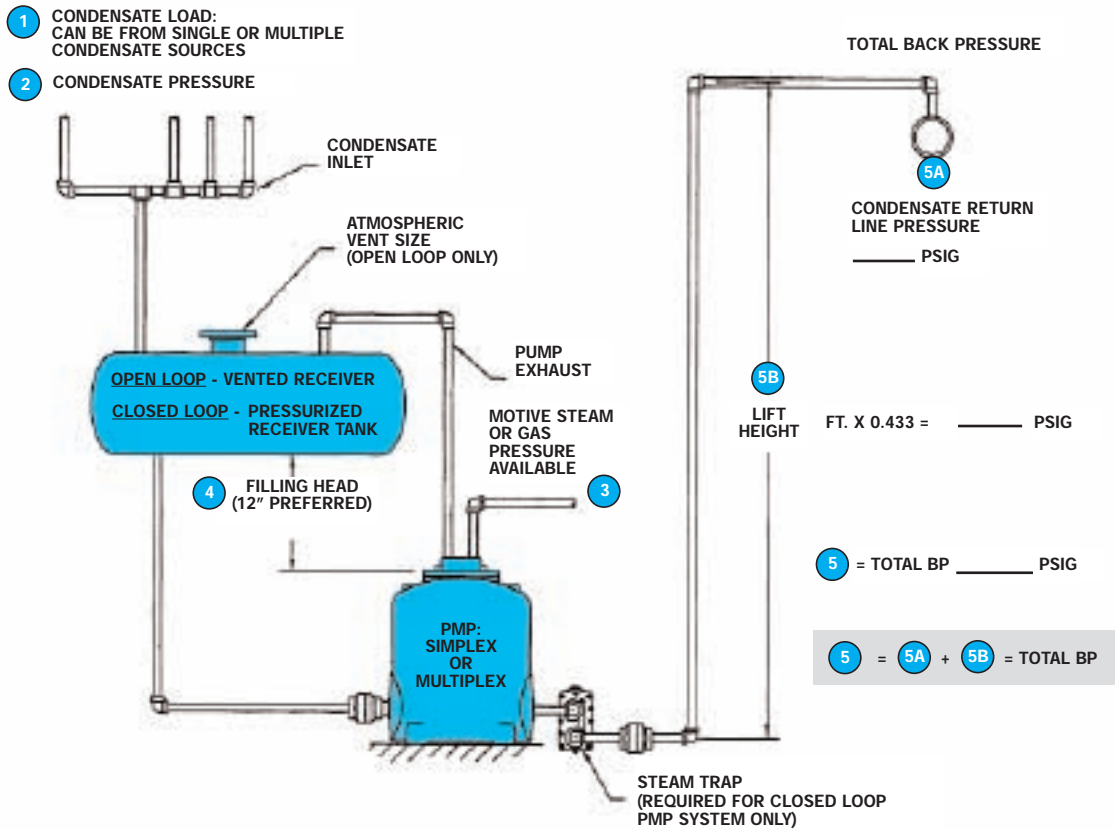

Simplex or Multiplex PMP System

NON-ELECTRIC CONDENSATE PUMPS

Sizing & Selection

Pressure Motive Pumps

PUMPS

Closed Loop System (Pressurized Reservoir)

RESERVOIR SIZING

When sizing Pressure Motive Pumps for closed loop return systems, a condensate reservoir should be installed on the inlet side of the pump and below the equipment to be drained. This will enable the condensate to collect while the pump is in the discharge cycle, thus preventing liquid backup into the equipment. The Reservoir Sizing Table (at right) gives the minimum pipe size & length to produce the required reservoir volume to accommodate the condensate load.

How to select: Determine the total condensate load to be pumped. Find that load value or greater in the table and move right to read the pipe lengths in feet with the diameters indicated above.

Customized reservoirs can be designed to accommodate specific space and dimensional requirements. It is critical for these designs to have adequate vapor space for condensate to collect. When the volume required is known, from the table at right, optional pipe diameters and lengths can be selected to provide the same or greater volume. This table will allow you to convert required volumes to customized sizes needed. Watson McDaniel can furnish customized Pressure Motive Pump Packages to fit your needs.

RESERVOIR PIPE LENGTH in feet (ft)

Condensate Load (lbs/hr)	Reservoir Pipe Size (Diameter)				
	3"	4"	6"	8"	10"
0-500	2'				
1,000	2'				
1,500	3'	2'			
2,000	3.5'	2'	1'		
3,000		3'	2'		
4,000		4'	2'	1'	
5,000		6'	3'	2'	
6,000			3'	2'	
7,000			3'	2'	
8,000			4'	2'	
9,000			4.5'	3'	2'
10,000			5'	3'	2'
20,000				5.5'	4'

Note: When back pressure against the pump outlet is less than 50% of the steam pressure to the heat exchanger, the above pipe lengths can be reduced by half.

DATA REQUIRED FOR SIZING PMP IN A CLOSED LOOP SYSTEM (pressurized reservoir)

Single Condensate Source

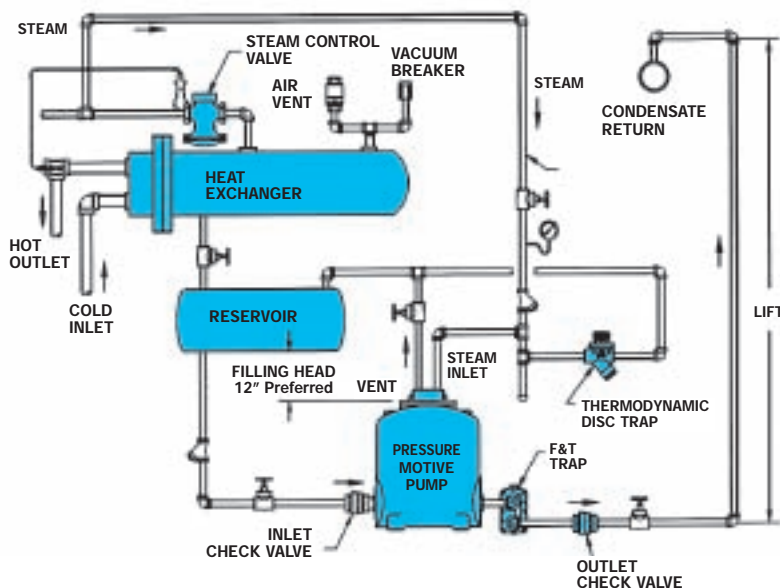

Condensate Load produced by Heat Transfer Equipment (i.e. heat exchangers, tank coils, jacketed kettles, etc.)
_____ lbs/hr

(If this information is not readily available, consult Engineering Section in the back of this catalog for additional methods of load determination.)

Motive Steam Pressure (Steam Motive Only):
___ PSIG

Total Back Pressure = a + b

a) Pressure required to lift condensate:

Vertical height in ft. x 0.433 = ___ PSIG

b) Pressure in condensate return line: ___ PSIG

Is there enough clearance under the equipment and/or piping to allow for the installation of the Reservoir and PMP with the Preferred Filling Head of 12" as illustrated?

To size the PMP and Trap combination, see PMPT or WPT Capacity charts for general reference.

(For additional information on the effect of the steam trap in a closed loop application, refer to expanded information later in this section. For more accurate sizing of Pump-Trap systems to account for system stall conditions, consult factory.)

To size the Reservoir, see Reservoir Pipe Length chart.

NON-ELECTRIC CONDENSATE PUMPS

Sizing & Selection

Pressure Motive Pumps

Open Loop System (Vented Receiver)

RECEIVER & VENT SIZING

When sizing a Pressure Motive Pump for an Open-Loop atmospheric return system, the amount of flash steam to be vented from the receiver must be calculated. Vent sizing is critical to maintain 0 PSIG in the receiver tank to allow free drainage of low pressure systems. Undersized vents will cause gradual pressure increase in the receiver. This impedes drainage from the condensate source, and can cause waterlogging of the system.

Usually the condensate load to be pumped comes from multiple sources. For each source determine

the pressure and load. Then go into the **Percent Flash Steam** table with the condensate pressure and move right until under the appropriate flash tank pressure to read the percentage of condensate that will flash into steam. Take the source load and multiply it by the decimal value of the percentage to calculate the amount (lbs/hrs) of flash steam. Repeat this for all condensate sources. Enter the **Vented Receiver Sizing** table with the **total flash steam load** to determine the correct sizes for receiver and vent.

VENTED RECEIVER SIZING (inches)			
Quantity of Flash Steam (lbs/hr)	Receiver Diameter	Receiver Length	Vent Line Diameter
75	4"	36"	1"
150	6"	36"	2"
300	8"	36"	3"
600	10"	36"	4"
900	12"	36"	6"
1200	16"	36"	6"
2000	20"	60"	8"
3000	24"	60"	8"
4000	26"	60"	10"
5000	28"	60"	10"
6000	30"	72"	12"
7000	32"	72"	12"
8000	36"	72"	14"

PERCENT (%) FLASH STEAM

Produced when condensate is discharged to atmosphere or into a flash tank controlled at various pressures

Condensate Pressure (PSIG)	Flash Tank Pressure (PSIG)								
	0	5	10	20	30	40	60	80	100
5	1.6	0.0							
10	2.9	1.3	0.0						
15	3.9	2.4	1.1						
20	4.9	3.3	2.1	0.0					
30	6.5	5.0	3.7	1.7	0.0				
40	7.8	6.3	5.1	3.0	1.4	0.0			
60	10.0	8.5	7.3	5.3	3.7	2.3	0.0		
80	11.8	10.3	9.1	7.1	5.5	4.2	1.9	0.0	
100	13.3	11.8	10.6	8.7	7.1	5.8	3.5	1.6	0.0
125	14.9	13.5	12.3	10.4	8.8	7.5	5.3	3.4	1.8
150	16.3	14.9	13.7	11.8	10.3	9.0	6.8	4.9	3.3
200	18.7	17.3	16.2	14.3	12.8	11.5	9.4	7.6	6.0
250	20.8	19.4	18.2	16.4	14.9	13.7	11.5	9.8	8.2
300	22.5	21.2	20.0	18.2	16.8	15.5	13.4	11.7	10.2
350	24.1	22.8	21.7	19.9	18.4	17.2	15.1	13.4	11.9
400	25.6	24.2	23.1	21.4	19.9	18.7	16.7	15.0	13.5

DATA REQUIRED FOR SIZING PMP IN AN OPEN LOOP SYSTEM (vented receiver)

Multiple Condensate Sources

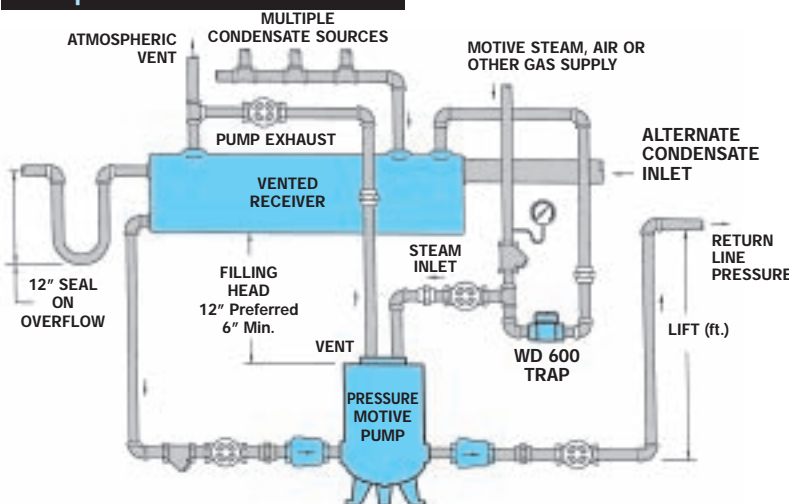

Source 1: ____ lbs/hr @ ____ PSIG
 Source 2: ____ lbs/hr @ ____ PSIG

Motive Gas and Pressure:
 (Steam, Air, Other) @ ____ PSIG

Total Back Pressure = a + b

a) Pressure required to lift condensate:

Vertical height ____ ft. x 0.433 = ____ PSIG

b) Pressure in return pipe: ____ PSIG

Is there enough clearance under the equipment and/or piping to allow for the installation of the Receiver and PMP with the Preferred Filling Head of 12" as illustrated?

To size the PMP, see Pump Capacity chart.

To size the Receiver and Vent connection, see Vented Receiver Sizing chart.

NON-ELECTRIC CONDENSATE PUMPS

Sizing & Selection

Pressure Motive Pumps

Watson McDaniel reserves the right to change the designs and/or materials of its products without notice.
©2010 Watson McDaniel Company

Problem: Stalled Heat Exchanger

DESCRIPTION:

STALL CONDITION WITH MODULATED STEAM FLOW

When a modulating valve is used to control product temperature in heat transfer equipment, the valve will open and close as necessary to meet the variable demand of the system to maintain the product at constant temperature. Therefore, when maximum heating is required, the supply valve will be fully open to satisfy the high steam demand requirement. At this point, pressure is also being supplied at its highest level, which may be sufficient to overcome total system back pressure.

As the product temperature is satisfied, demand decreases and the valve correspondingly begins to close, reducing pressure differential. If demand is satisfied, the valve modulates to its fully closed position. Inlet supply pressure will eventually fall below system back pressure, resulting in system stall. This leads to poor heat transfer and water hammer as condensate backs up in the heat transfer equipment.

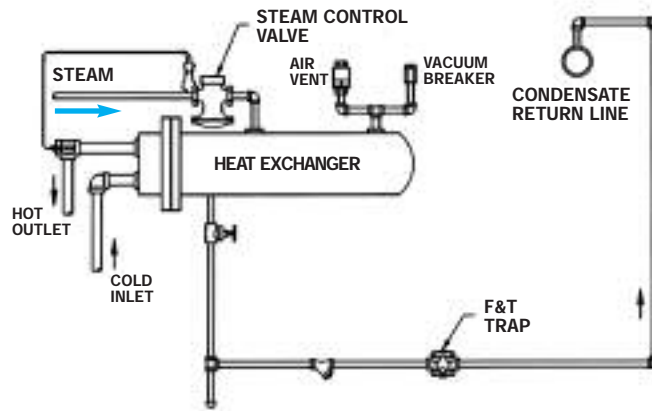

Heat Exchanger System without PMP

Solution: Use PMP & Steam Trap Combination

DESCRIPTION:

USE A PRESSURE MOTIVE PUMP AND STEAM TRAP COMBINATION

(Available in INTERNAL and EXTERNAL Steam Trap designs)

When the supply valve is fully open and inlet pressure exceeds back pressure, condensate forming in the heat transfer equipment will be pushed through the pump and steam trap into the condensate return line. As the supply valve begins to close and the back pressure exceeds inlet pressure, any condensate forming inside the heat transfer equipment will drain by gravity into the pump tank. The condensate will accumulate in the pump tank until the float mechanism reaches its trip point. The "tripping" of the mechanism opens the motive valve to allow high pressure steam into the tank to drive the condensate from the tank to the condensate return line.

Note: A larger steam trap than normally required to drain the heat transfer equipment must be used to handle the high instantaneous discharge rate of the pump. See additional information in this catalog for sizing guidelines.

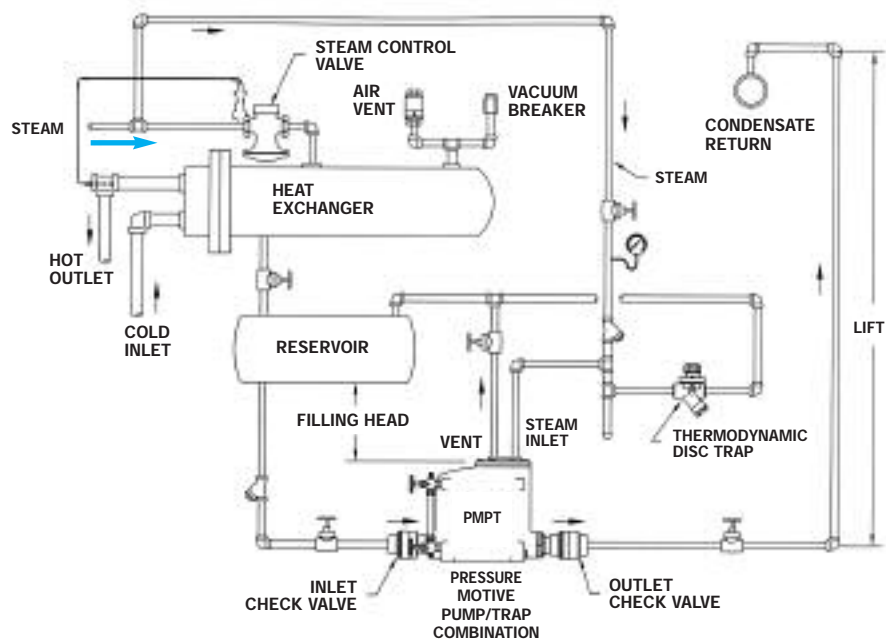

Heat Exchanger System with PMP & Internal Trap (PMPT) (Closed Loop System)

Sizing & Selection

Pressure Motive Pumps

CLOSED LOOP SYSTEMS – SIZING CONSIDERATIONS for PUMP-TRAP COMBINATION

What is Stall?

STALL is the condition of a modulating system where inlet pressure can no longer overcome back pressure, preventing condensate drainage and resulting in poor heat transfer and waterhammer.

Although Pressure Motive Pumps can be supplied as stand-alone units, the vast majority of industrial condensate transfer applications require a complete system of components to function both properly and efficiently. This section is intended to familiarize the user with the information and components required to provide an efficient system:

The Solution to Stall

Install a Watson McDaniel Pump and Steam Trap Combination – available in both Internal and External Steam Trap designs.

The PMPT Pump with Internal Steam Trap should be considered for compactness, while the WPT Series Pump-Trap Combination with External Steam Trap should be considered when capacities exceed the capability of the PMPT.

Why is a Steam Trap necessary after the PMP in a Closed Loop system?

Because this type of system operates with a modulating supply valve as described above, the pressure may, at times, both exceed or fall below system back pressure. The pump is only required during stall loads. Therefore, a steam trap is still required to prevent steam from discharging into the return line at times when the supply pressure exceeds the back pressure. When properly sized and installed, these two components will automatically work in conjunction with each other requiring no manual operation.

It is important to note that sizing the steam trap in a pump-external trap* combination application differs from sizing a steam trap alone. Please refer to additional information below.

** Although the steam trap is internal in the PMPT Series, it is still appropriate to follow the guidelines below for sizing confirmation.*

Sizing of a Pump-Trap Combination for a Closed Loop System

Although the PMP and Steam Trap operate in conjunction with each other, each component must be considered individually, as there are specific considerations for closed loop systems. See below for detailed explanation and appropriate guidelines for sizing of both the PMP and Trap components of the Pump-Trap Combination:

Proper Sizing of the PMP in a Pump-Trap Application

When required for drainage of heat transfer equipment supplied by a modulating control valve, the PMP need only be sized for the stall load, which is often considerably less than equipment design load leading to a smaller PMP being required. The point at which stall occurs can be calculated using either Stall Charts or appropriate formulas as shown on the following pages.

Proper Sizing of the Steam Trap in a Pump-Trap Application

In such an application, the steam trap must be sized not only to handle the full design load, but also sized to handle the high instantaneous flow rates from the discharge of the pump at stall conditions – which can be well in excess of 3 times the steady-state load of the pump! Therefore, it is appropriate to size the steam trap for both sets of conditions using the following guidelines:

- Steam Trap sizing based on Full Design Load of the Heat Transfer Equipment:
Full Design Load X appropriate Safety Load Factor = Total Load for Steam Trap Sizing
- Steam Trap sizing based on Instantaneous Discharge of the PMP – at stall conditions:
Stall Load (as determined) at 1/4 PSI differential for Steam Trap Sizing

Sizing & Selection

Pressure Motive Pumps

Watson McDaniel reserves the right to change the designs and/or materials of its products without notice.
©2010 Watson McDaniel Company

Predicting Stall

Stall can be predicted with relative accuracy by either plotting values on a Stall Chart or by calculation using appropriate formulas. These methods are then used to determine the percentage of heat load at stall. Examples of each method are offered so the user may choose the method with which they are most comfortable.

The example below is for a typical heat transfer application**, such as a heat exchanger where steam may be used to heat a constant flow of water at a fixed temperature. The parameters of such an application can be summarized as:

- The flow of the fluid to be heated is constant
- The desired outlet temperature of the heated fluid is to remain constant
- The steam for heating is to be supplied with a modulating valve (i.e. varying inlet pressure)

** Applications with alternate parameters will require different equations and guidelines for prediction of stall conditions. Consult factory for other such applications.

Example:

Consider a heat exchanger supplied with 40 PSIG steam through a modulating valve that is designed to heat a constant water flow of 145 GPM from 60 °F to 140 °F. Condensate will need to be lifted 23 ft. into a return line that has approximately 5 PSIG back pressure.

Before the charts or formulas can be consulted, some additional conversions are first required:

- 1) **The Saturated Temperature of the incoming steam:** In this example, consult the Saturated Steam Table (included in the Engineering Section of this catalog) to determine the Saturated Temperature of 40 PSIG steam is 287 °F.
- 2) **The equivalent Saturated Temperature of the total BACK PRESSURE:** The total back pressure is equal to the lift height equivalent pressure, plus any pressure that may exist in the return line.
 - 23 ft. Lift Height x 0.433 = 10 PSIG
 - Return Line Pressure = 5 PSIG

Therefore, the total BACK PRESSURE in this example is 15 PSIG. Consulting the Saturated Steam Table, the saturated temperature of 15 PSIG steam is 250 °F.

DETERMINING PERCENTAGE OF HEAT LOAD AT STALL

The parameters required for determining stall can now be summarized as follows:

- Inlet Steam Pressure at Full (100%) Load = 40 PSIG (P_s)
- Inlet Steam Temperature at Full (100%) Load = 287 °F (T_s)
- Outlet Temperature of Heated Fluid = 140 °F (T_2)
- Back Pressure (lift height + line pressure) = 15 PSIG (P_b)
- Back Pressure equivalent saturated steam temperature = 250 °F (T_b)

Mathematical Solution

$$\begin{aligned} \text{\% Heat Load at Stall} &= \frac{T_b - T_2}{T_s - T_2} \times 100\% \\ &= \frac{250 - 140}{287 - 140} \times 100\% \\ &= \frac{110}{147} \times 100\% \\ &= 74.8\% \end{aligned}$$

Graphical Solution (see Figure No. 1)

- 1) On the Left Vertical Axis, plot the Inlet Steam Temperature (T_s): 287 °F.
- 2) On the Left Vertical Axis, find the Outlet Temperature of the fluid to be heated (T_2): 140 °F. Plot this point directly across on the Right Vertical Axis. Draw line between points T_s and T_2 .
- 3) On the Right Vertical Axis, plot the Back Pressure: 15 PSIG. Draw a horizontal line from this point to the Left Vertical Axis.
- 4) Locate the point at which the above lines intersect. Draw vertical line from this point to the Bottom Horizontal Axis to determine the Percentage of Load at which Stall occurs – 75% in this example.

NON-ELECTRIC CONDENSATE PUMPS

Sizing & Selection

Pressure Motive Pumps

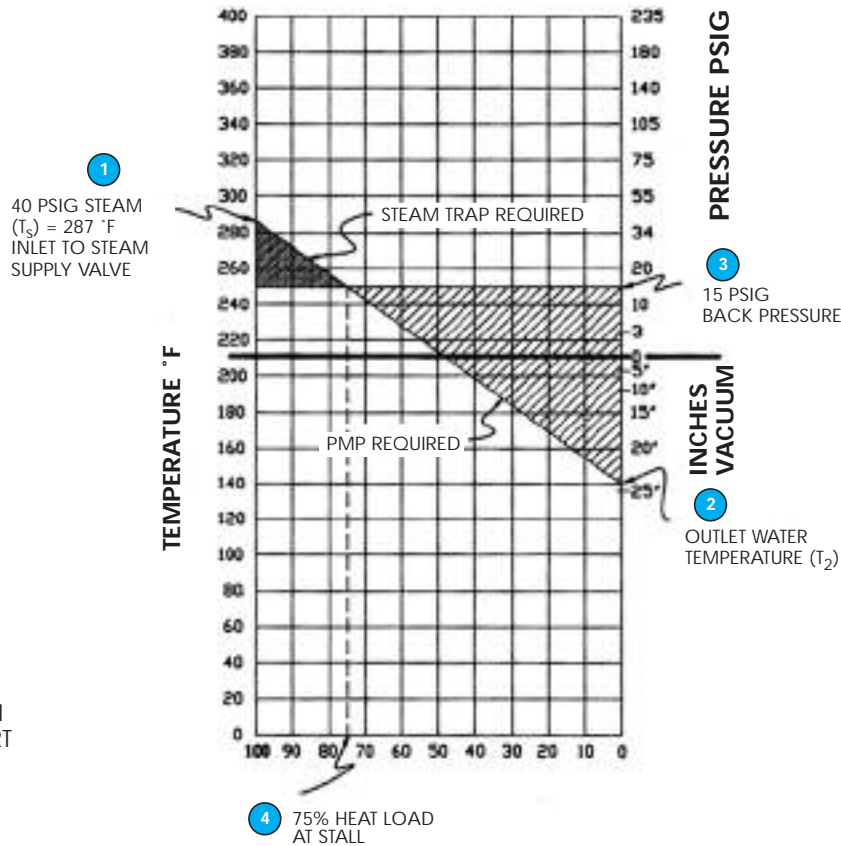

Figure No. 1
STALL CHART

DETERMINING LOAD AT STALL

The load was not specified in the example provided. However, sufficient information was provided for its calculation. Here is what is known:

- Steam Supply Pressure = 40 PSIG
- Constant Water Flow = 145 GPM
- Water Heating Requirements = 60 °F to 140 °F

Consulting the Engineering Section in the back of this catalog, the following equation for steam load requirements at heat exchanger full load can be used:

$$\begin{aligned}
 \text{Steam Load in lbs/hr} &= \frac{\text{GPM} \times \text{Temp. Rise } ^\circ\text{F}}{2} \\
 &= \frac{145 \times (140-60)}{2} \\
 &= 5,800 \text{ lbs/hr}
 \end{aligned}$$

At 100% open, the inlet steam valve will supply 5,800 lbs/hr for heating. We can now determine the stall load to be used for proper sizing of the Pump-Trap Combination. From the previous section, stall was determined to occur at 75% of the full load. Therefore:

$$\text{Stall Load} = 5,800 \text{ lbs/hr} \times 0.75 = 4,350 \text{ lbs/hr}$$

Finally, using the guidelines previously noted within this section, the PMP and Steam Trap can be properly sized and selected. As always, consult the factory for additional information and sizing assistance when needed.

NON-ELECTRIC CONDENSATE PUMPS

Customized Skid Packages

Watson McDaniel reserves the right to change the designs and/or materials of its products without notice.
©2010 Watson McDaniel Company

Pressure Motive Condensate Pumping Systems

PUMPS

Custom Fabricated Units

Watson McDaniel's fully equipped ASME qualified fabrication facility stands ready to assist you with all of your fabrication needs. Our engineering staff specializes in the design of Pressure Motive Condensate Pumping Systems for both industrial and institutional applications. You can order either standard packages, available from stock, or specialized systems to meet your specific needs.

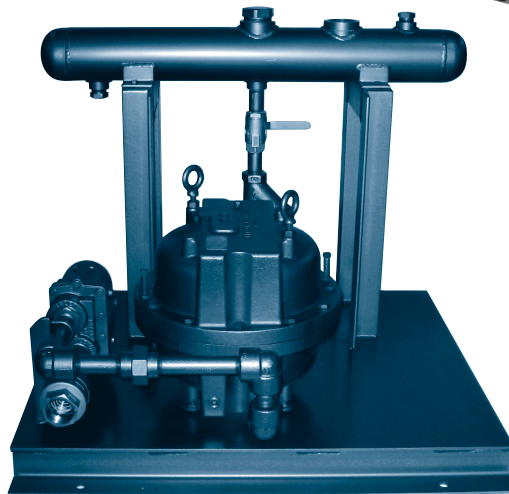
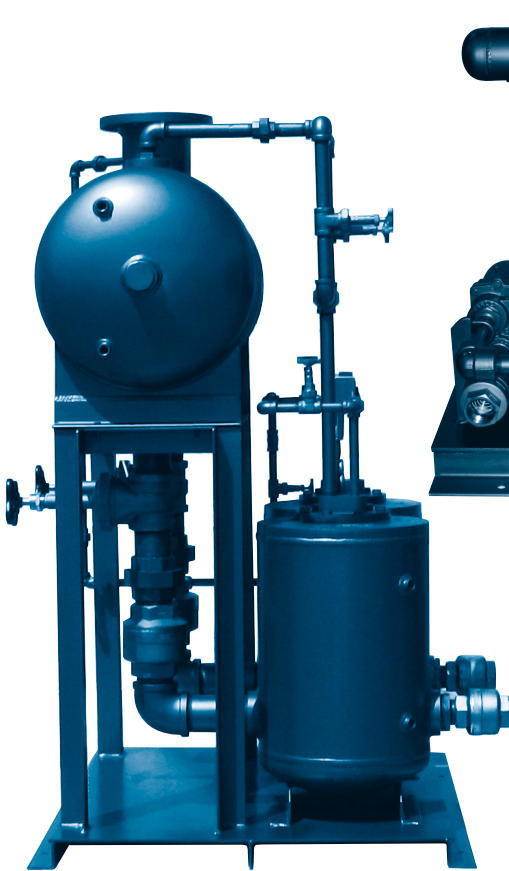
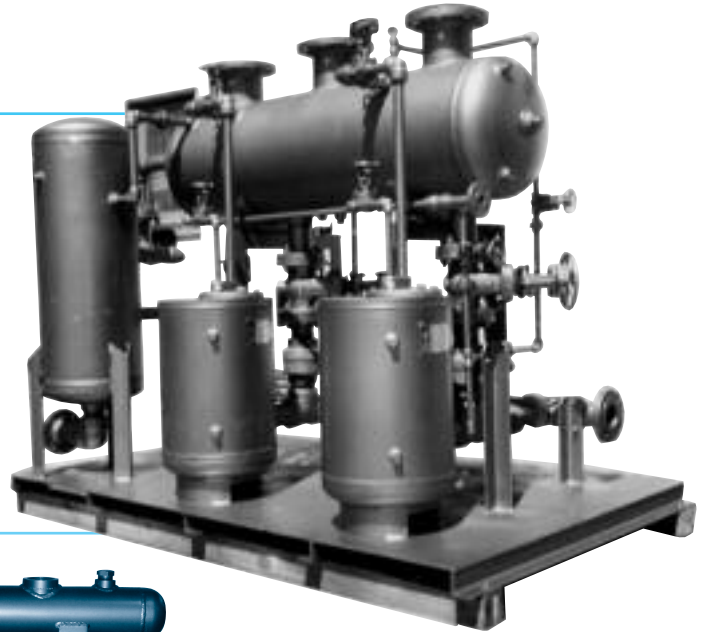

ASME
Certified



NON-ELECTRIC CONDENSATE PUMPS

Custom Skid Packages

Pressure Motive Condensate Pumping Systems

DESCRIPTION OF CUSTOM SYSTEM

This "Closed Loop" Duplex Pump package utilizes two PMPF Pumps, two FTE Steam Traps, and one 65 gallon receiver tank equipped with a safety relief valve. The Receiver is vented to take the flash steam away at 29 PSIG for usage elsewhere in the plant. To accomplish this, our **pilot-operated back pressure regulator (BPR)** is mounted just off the vent line and set to maintain the 29 PSIG pressure. If pressure exceeds the set, the BPR unit will dump to atmosphere thru the supply acoustic silencer.

Another custom feature is an overflow circuit utilizing a custom flash tank equipped with a **Temperature Regulator** for cooling applications. In the event of a pump failure, the flooded receiver will overflow the hot condensate into the flash vessel where steam will vent to atmosphere while the condensate gets injected with cold water to safely dump to drain.

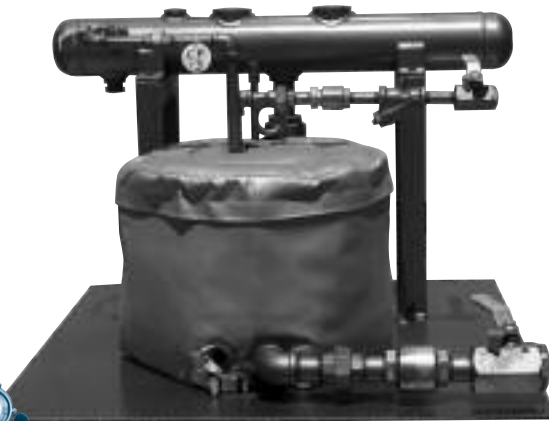
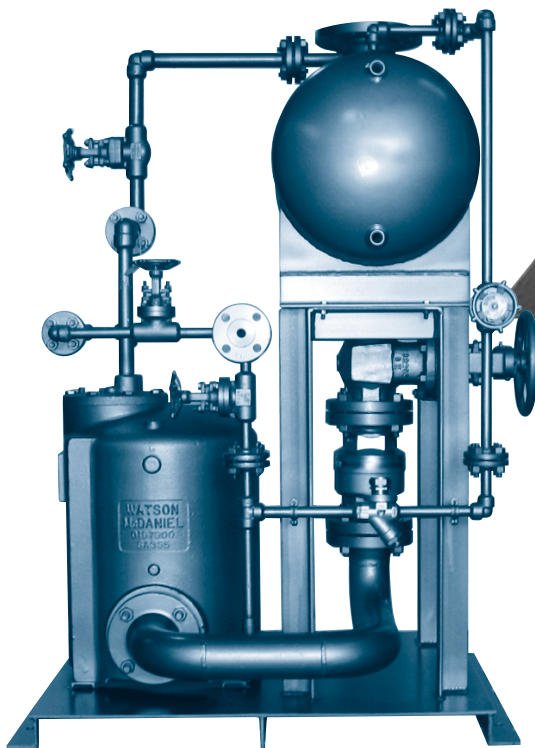
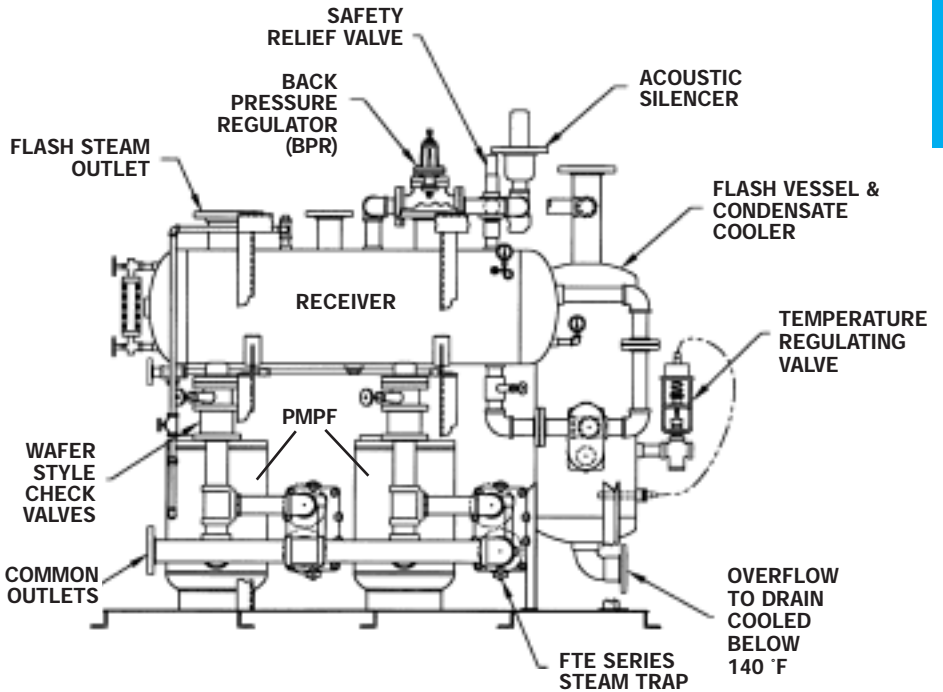

ELECTRIC PUMPS

W4100 & W4200

Electric Condensate Pump

Watson McDaniel reserves the right to change the designs and/or materials of its products without notice.
©2010 Watson McDaniel Company

Model	W4100	W4200
Tank Sizes	8/15/30/45/60/95 Gal.	6/15/24/36/50 Gal.
Connections	NPT	NPT
Tank Material	Fabricated Carbon Steel	Cast Iron
Max Disch. Press.	50 PSIG *	50 PSIG *
TMO/TMA	190°F	190°F
Options	Mechanical & electrical alternators; gauge glass; thermometer; discharge pressure gauges; isolation valves; magnetic starters; 1750 RPM motors; control panels; oversized or stainless steel receivers; high temperature components	

* Optional higher ratings available.

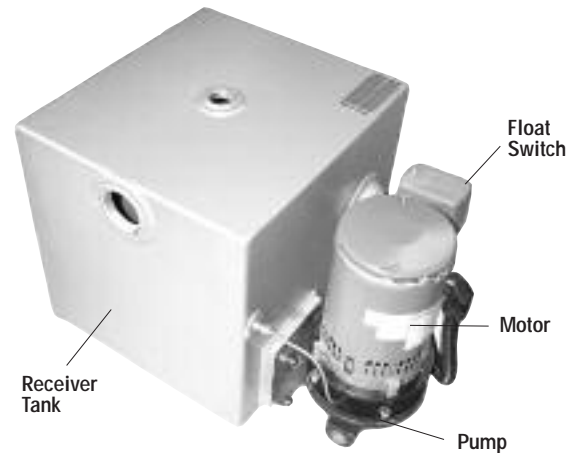

TYPICAL APPLICATIONS

The primary purpose of the W4100 and W4200 electric condensate pumps are to return condensate back to the boiler. Pumping condensate over 190°F is not recommended with these pumps due to potential mechanical seal failure.

HOW IT WORKS

The float, which is connected to the switch assembly rises when condensate enters the receiver tank. When the float rises above its set point, it energizes the motor on the pump. Once started, the pump will continue to run until the water level drops below the bottom position of the float switch. There it will de-energize the motor to shut off the pump. This cycle repeats as condensate begins to fill the receiver tank.

FEATURES

- Fabricated steel receivers (W4100) or cast iron receivers (W4200)
- Simplex and duplex packages
- Bronze-fitted centrifugal pumps
- Energy-efficient 3450 RPM motors
- Automatic venting
- Ceramic pump seal
- Heavy-duty float switch
- All steel receivers, and iron receivers over 24 gallons include a threaded NPT overflow port

SAMPLE SPECIFICATION

Pump(s) shall be of the centrifugal type with two-piece enclosed brass impeller, cast iron housing and stainless steel motor shaft. The float switch shall be two-pole with plastic case, stainless steel float and shafting, and double-break silver contacts. A flat perforated brass strainer shall be provided in the inlet of the pump from the tank.

INSTALLATION

Place on an elevated, level and substantial foundation in a clean, dry and accessible area. Locate receiver tank inlet below lowest point of the condensate return lines.

MAINTENANCE

At regular intervals, check the motor lubrication, unless the motor is equipped with a permanently lubricated bearing.

OPTIONS

- Mechanical and electrical alternators
- Gauge glass
- Thermometer
- Discharge pressure gauges
- Isolation valves
- Magnetic starters with HOA selector switch
- 1750 RPM motors, larger pumping capacities & higher discharge pressures
- Wide variety of control panels
- Oversized receivers (45, 60 & 95 gallons)
- Stainless Steel receivers
- High Temperature (250°F) Components

HOW TO ORDER

Specify the discharge pressure, gallons per minute and voltage requirements when ordering.

ELECTRIC PUMPS

W4100 & W4200

Electric Condensate Pump

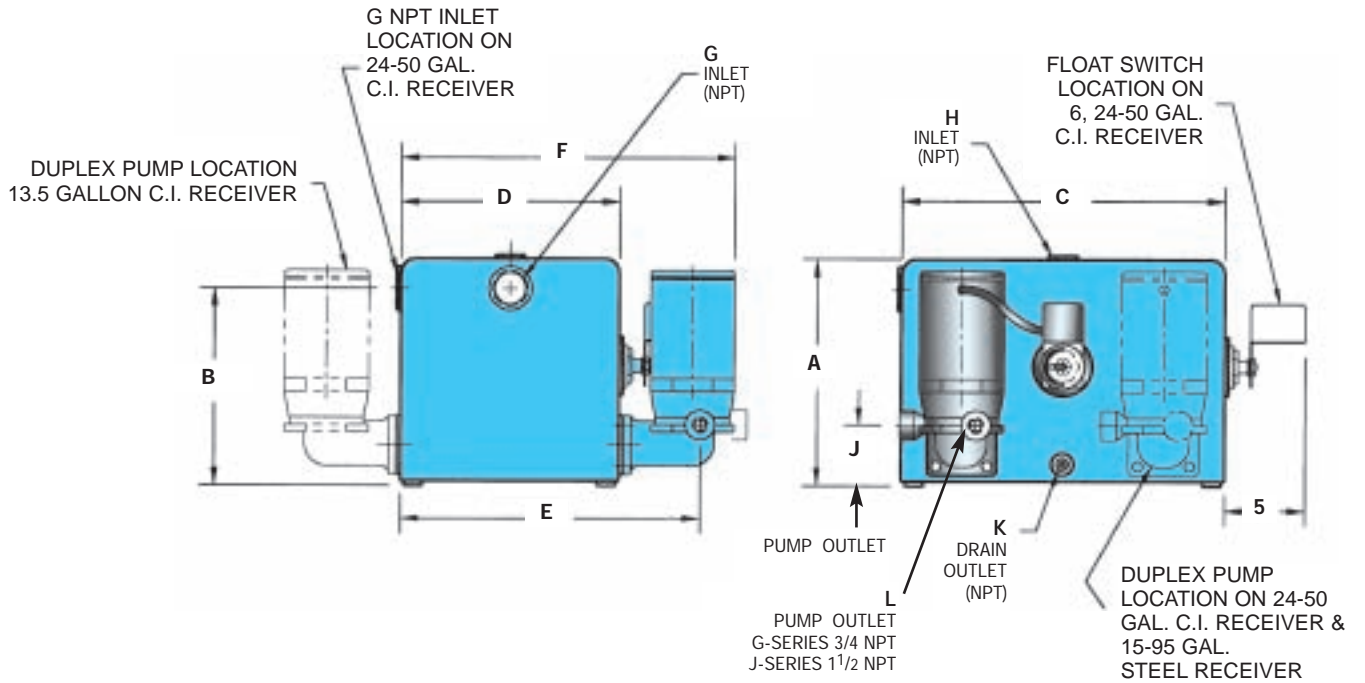

W4100 (Steel Receiver) Dimensions - inches

Series	Receiver Size	A	B	C	D	E	F	G	H	J	K	L
G	8 gallon	12 ³ / ₄	10 ¹ / ₂	12 ¹ / ₂	12 ¹ / ₂	18	21 ¹ / ₂	2	1 ¹ / ₂	4 ¹ / ₈	1/2	3/4
	15 gallon	14 ³ / ₈	12 ³ / ₈	17	15	20 ¹ / ₂	23 ¹ / ₄	2				
	30 gallon	18 ³ / ₈	16 ¹ / ₈	22	18	23 ¹ / ₂	28	2 ¹ / ₂				
J	45 gallon	26 ³ / ₈	24 ¹ / ₈	22	18	---	29 ⁵ / ₁₆	2 ¹ / ₂	1	3 ¹ / ₄	1/2	1 ¹ / ₂
	60 gallon	28 ³ / ₈	26 ¹ / ₈	28	18	---	29 ⁵ / ₁₆	2 ¹ / ₂				
	95 gallon	28 ³ / ₈	26 ¹ / ₈	28	28	---	39 ⁵ / ₁₆	2 ¹ / ₂				

W4200 (Cast Iron Receiver) Dimensions - inches

Series	Receiver Size	A	B	C	D	E	F	G	H	J	K	L
G	6 gallon	4 ¹ / ₂	12 ¹ / ₂	14 ¹ / ₂	12 ⁵ / ₈	18 ¹ / ₄	20 ⁷ / ₁₆	2	3/4	4 ³ / ₃₂	3/4	3/4
	15 gallon	14 ⁷ / ₈	13 ¹ / ₈	18 ¹ / ₂	13 ¹ / ₂	19 ¹ / ₈	24	2	1	3 ³ / ₄	1/2	3/4
	24 gallon	19 ¹ / ₈	15 ⁵ / ₈	25 ⁷ / ₈	15	20 ¹ / ₃₂	22 ¹³ / ₁₆	2	1	4 ¹ / ₈	3/4	3/4
	36 gallon	18 ⁵ / ₈	15 ¹ / ₈	27 ²¹ / ₆₄	22 ¹ / ₂	27 ¹⁷ / ₃₂	31 ³ / ₄	3	1	4 ¹ / ₈	3/4	3/4
J	36 gallon	18 ⁵ / ₈	15 ¹ / ₈	27 ²¹ / ₆₄	22 ¹ / ₂	---	35 ³ / ₈	3	1	4 ³ / ₈	3/4	1 ¹ / ₂
	50 gallon	18 ⁵ / ₈	15 ¹ / ₈	27 ²¹ / ₆₄	31	---	43 ⁷ / ₈	3	1	4 ³ / ₈	3/4	1 ¹ / ₂

ELECTRIC PUMPS

W4100

Watson McDaniel reserves the right to change the designs and/or materials of its products without notice.
©2010 Watson McDaniel Company

Electric Condensate Pump with Steel Receiver

PUMPS

CAPACITIES								
EDR	Discharge Pressure (PSIG)	Flow Rate (GPM)	Motor HP	Receiver Capacity (gallons)	Simplex Model #	Weight (lbs)	Duplex Model #	Weight (lbs)
8000	20	12	1/3	8	W4028G	90	N/A	N/A
2000	20	3	1/3	15	W4122G	125	W4122GD	185
4000	20	6	1/3	15	W4124G	125	W4124GD	185
6000	20	9	1/3	15	W4126G	125	W4126GD	185
8000	20	12	1/3	15	W4128G	125	W4128GD	185
10000	20	15	1/2	30	W41210G	190	W41210GD	240
15000	20	22.5	1/2	30	W41215G	190	W41215GD	240
20000	20	30	3/4	30	W41220G	200	W41220GD	250
25000	20	37.5	3/4	45	W41225J	285	W41225JD	350
30000	20	45	1	45	W41230J	285	W41230JD	350
40000	20	60	1 1/2	60	W41240J	335	W41240JD	405
50000	20	75	2	95	W41250J	385	W41250JD	460
2000	30	3	1/2	15	W4132J	180	W4132JD	250
4000	30	6	1/2	15	W4134J	180	W4134JD	250
6000	30	9	1/2	15	W4136J	180	W4136JD	250
8000	30	12	1/2	15	W4138J	180	W4138JD	250
10000	30	15	3/4	15	W41310J	185	W41310JD	250
15000	30	22.5	1	30	W41315J	230	W41315JD	300
20000	30	30	1	30	W41320J	230	W41320JD	300
25000	30	37.5	1	45	W41325J	285	W41325JD	350
30000	30	45	1 1/2	45	W41330J	290	W41330JD	355
40000	30	60	2	60	W41340J	340	W41340JD	410
50000	30	75	3	95	W41350J	395	W41350JD	470
2000	40	3	1	15	W4142J	190	W4142JD	270
4000	40	6	1	15	W4144J	190	W4144JD	270
6000	40	9	1	15	W4146J	190	W4146JD	270
8000	40	12	1	15	W4148J	190	W4148JD	270
10000	40	15	1	15	W41410J	190	W41410JD	270
15000	40	22.5	1 1/2	30	W41415J	240	W41415JD	310
20000	40	30	1 1/2	30	W41420J	240	W41420JD	310
25000	40	37.5	1 1/2	45	W41425J	290	W41425JD	355
30000	40	45	2	45	W41430J	295	W41430JD	360
40000	40	60	2	60	W41440J	240	W41440JD	410
50000	40	75	3	95	W41450J	395	W41450JD	470
2000	50	3	2	15	W4152J	195	W4152JD	275
4000	50	6	2	15	W4154J	195	W4154JD	275
6000	50	9	2	15	W4156J	195	W4156JD	275
8000	50	12	2	15	W4158J	195	W4158JD	275
10000	50	15	2	15	W41510J	195	W41510JD	275
15000	50	22.5	2	30	W41515J	245	W41515JD	320
20000	50	30	3	30	W41520J	255	W41520JD	330
25000	50	37.5	3	45	W41525J	305	W41525JD	385
30000	50	45	3	45	W41530J	305	W41530JD	385
40000	50	60	5	60	W41540J	370	W41540JD	500
50000	50	75	5	95	W41550J	430	W41550JD	500

Notes: 1) EDR = Square Feet of Equivalent Direct Radiation
2) Capacity of Steam (lbs/hr) = EDR x 0.25

ELECTRIC PUMPS

W4200

Electric Condensate Pump with Cast Iron Receiver

PUMPS

CAPACITIES

EDR	Discharge Pressure (PSIG)	Flow Rate (GPM)	Motor HP	Receiver Capacity (gallons)	Simplex Model #	Weight (lbs)	Duplex Model #	Weight (lbs)
2000	20	3	1/3	6	W4222G	150	N/A	N/A
4000	20	6	1/3	6	W4224G	150	N/A	N/A
6000	20	9	1/3	15	W4226G	260	W4226GD	295
8000	20	12	1/3	15	W4228G	260	W4228GD	295
10000	20	15	1/2	15	W42210G	260	W42210GD	295
15000	20	22.5	1/2	24	W42215G	300	W42215GD	335
20000	20	30	3/4	36	W42220G	410	W42220GD	445
25000	20	37.5	3/4	36	W42225J	350	W42225JD	420
30000	20	45	1	36	W42230J	355	W42230JD	430
40000	20	60	1 1/2	50	W42240J	420	W42240JD	500
50000	20	75	2	50	W42250J	425	W42250JD	510
2000	30	3	1/2	6	W4232J	165	N/A	N/A
4000	30	6	1/2	6	W4234J	165	N/A	N/A
6000	30	9	1/2	15	W4236J	295	W4236JD	360
8000	30	12	1/2	15	W4238J	295	W4238JD	360
10000	30	15	3/4	15	W42310J	300	W42310JD	365
15000	30	22.5	1	24	W42315J	305	W42315JD	380
20000	30	30	1	36	W42320J	355	W42320JD	430
25000	30	37.5	1	36	W42325J	355	W42325JD	430
30000	30	45	1 1/2	36	W42330J	360	W42330JD	440
40000	30	60	2	50	W42340J	425	W42340JD	510
50000	30	75	3	50	W42350J	435	W42350JD	525
2000	40	3	1	6	W4242J	170	N/A	N/A
4000	40	6	1	6	W4244J	170	N/A	N/A
6000	40	9	1	15	W4246J	295	W4246JD	360
8000	40	12	1	15	W4248J	295	W4248JD	360
10000	40	15	1	15	W42410J	295	W42410JD	360
15000	40	22.5	1 1/2	24	W42415J	310	W42415JD	390
20000	40	30	1 1/2	36	W42420J	360	W42420JD	440
25000	40	37.5	1 1/2	36	W42425J	360	W42425JD	440
30000	40	45	2	36	W42430J	365	W42430JD	450
40000	40	60	2	50	W42440J	425	W42440JD	510
50000	40	75	3	50	W42450J	435	W42450JD	525
2000	50	3	2	6	W4252J	175	N/A	N/A
4000	50	6	2	6	W4254J	175	N/A	N/A
6000	50	9	2	15	W4256J	315	W4256JD	395
8000	50	12	2	15	W4258J	315	W4258JD	395
10000	50	15	2	15	W42510J	315	W42510JD	395
15000	50	22.5	2	24	W42515J	330	W42515JD	415
20000	50	30	3	36	W42520J	370	W42520JD	460
25000	50	37.5	3	36	W42525J	370	W42525JD	460
30000	50	45	3	36	W42530J	370	W42530JD	460
40000	50	60	5	50	W42540J	445	W42540JD	535
50000	50	75	5	50	W42550J	445	W42550JD	535

Notes: 1) EDR = Square Feet of Equivalent Direct Radiation

2) Capacity of Steam (lbs/hr) = EDR x 0.25