



SOURIAU

Backshell Accessories



8LT, 8T & 8D Series

Aluminum Backshells & Caps



Presentation

Souriau offers a full range of aluminum backshells and caps. The best choice for a global solution provider.

Cost & time saving

- One supplier for connector and accessories.

A global RoHS solution

- With Zinc-Nickel accessories, Souriau offers a complete RoHS solution.
- Nickel, Cadmium and Black anodize finishes also available.

A wide range

- 6 backshell types and 2 angles.
- Caps for receptacle and plugs.
- Available for 38999 Series I, II, III & IV.

High reliability

- Conforming to AS85049 standards for backshells.
- Conforming to D38999 standards for caps.

Contents

Backshells

• Applications / Backshells description	04
• Ordering information	05
• Dimensions	06
• Recommended installation torque	09
• Band-it	09
• Band lock type 05 assembly	10
• Double cone type 06 assembly	11

Caps

• Applications / Caps description	12
• Ordering information	12
• Dimensions	13
• Comparison of plating codes	14

8LT, 8T & 8D Series Aluminum Backshells



Applications / Backshells description



Backnut

The backnut compresses the connector sealing grommet. It's the cost efficient solution to avoid grommet deformations and leakage infiltrations.



Cable clamp

Cable clamp is used to prevent wires and cables from pulling on the contacts and damaging the termination. It is available in straight or 90° angle.



Crimp ring

Eliminates EMI leakage paths, providing reliable and repairable shield terminations.



Shrink boot

Backshell ideal for environmental protection of connector wire terminations in most harsh environments including ground military equipments.

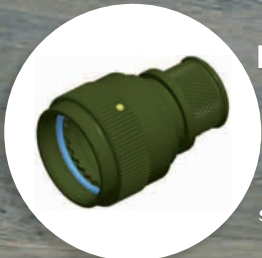

Band lock

This backshell type offers a complete grounded backshell, shield termination, and environmental sealing.



Double cone

Ensures the shielding by clamping the braid with a screwing system, developed according to HE308 standard.



Aeronautic backshells:
Backnut, Cable clamp
& Crimp ring versions



Ground backshells:
Crimp ring, Shrink boot, Band lock
& Double cone versions



8LT, 8T & 8D Series Aluminum Backshells

Ordering information

Aluminum backshells for 8LT & 8T Series

Basic Series	8T	AB	05	A	16	W	S	01	-																				
Accessories type																													
Type:																													
01: Backnut	04: Crimp ring																												
02: Cable clamp	05: Band lock																												
03: Shrink boot	06: Double cone																												
Angle:																													
A: Straight																													
B: 90° (Type 02 only)																													
Shell size:																													
08, 10, 12, 14, 16, 18, 20, 22, 24	<table border="1"> <tr> <td>Shell size 8T</td> <td>08</td><td>10</td><td>12</td><td>14</td><td>16</td><td>18</td><td>20</td><td>22</td><td>24</td> </tr> <tr> <td>= Shell size 8LT</td> <td>09</td><td>11</td><td>13</td><td>15</td><td>17</td><td>19</td><td>21</td><td>23</td><td>25</td> </tr> </table>									Shell size 8T	08	10	12	14	16	18	20	22	24	= Shell size 8LT	09	11	13	15	17	19	21	23	25
Shell size 8T	08	10	12	14	16	18	20	22	24																				
= Shell size 8LT	09	11	13	15	17	19	21	23	25																				
Finish:																													
Z: Black zinc nickel																													
W: Olive green cadmium																													
F: Nickel																													
A: Black anodized																													
Self locking option:																													
None																													
S: Self locking (available for Types 01 & 02 - mandatory for Type 05)																													
Cable entry (Type 05 only):																													
01, 02 (02 mandatory for shell size 08 & 10)																													
Drain hole option:																													
None																													
D: Drain hole (Type 03 only)																													

Aluminum backshells for 8D Series

Basic Series	8D	AB	05	A	17	W	S	02	-
Accessories type									
Type:									
01: Backnut	04: Crimp ring								
02: Cable clamp	05: Band lock								
03: Shrink boot									
Angle:									
A: Straight									
B: 90° (Type 02 only)									
Shell size:									
09, 11, 13, 15, 17, 19, 21, 23, 25									
Finish:									
Z: Black zinc nickel									
W: Olive green cadmium									
F: Nickel									
A: Black anodized									
Self locking option:									
None									
S: Self locking (available for Types 01 & 02 - mandatory for Type 05)									
Cable entry (Type 05 only):									
02, 03 (03 mandatory for shell size 09 & 11)									
Drain hole option:									
None									
D: Drain hole (Type 03 only)									

8LT, 8T & 8D Series Aluminum Backshells



Dimensions

Aluminum backshell Type 01 - Backnut

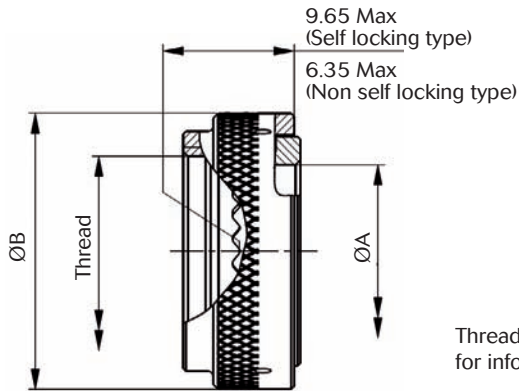

Thread: See page 8 for information.

Shell size		ØA Min	ØB Max
8LT & 8D	8T		
09	08	6.7	17.9
11	10	9.95	20.9
13	12	12.85	24.3
15	14	17.0	27.9
17	16	19.25	31.3
19	18	21.7	35.3
21	20	24.7	38.1
23	22	27.8	41.5
25	24	32.0	44.5

Aluminum backshell Type 02 - Cable clamp

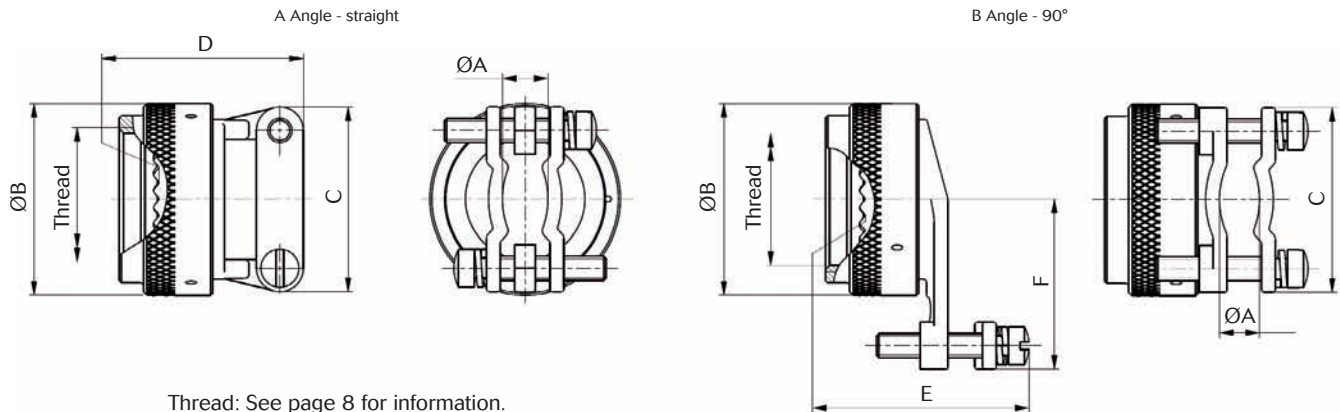

Thread: See page 8 for information.

Shell size		ØA		ØB Max	C Max	D Max	E Max	F Max
8LT & 8D	8T	Min	Max					
09	08	2.49	5.94	17.9	21.5	23.1	29.5	20
11	10	3.89	5.94	20.9	21.5	23.1	29.5	21.5
13	12	4.83	8.33	24.3	24.5	25.6	31.5	23.5
15	14	6.60	11.61	27.9	27.5	26.9	35.8	25.5
17	16	7.19	15.6	31.3	31.5	29.4	40.1	27.5
19	18	8.26	16.1	35.3	35.5	35.8	40.6	30.5
21	20	8.71	17.73	38.1	37	38.3	42.7	31.5
23	22	9.68	20.9	41.5	40.5	42.1	46.2	34.5
25	24	10.62	21.67	44.5	45	44.7	49	36.5

Note: All dimensions are in millimeters (mm)

8LT, 8T & 8D Series Aluminum Backshells



Aluminum backshell Type 03 - Shrink boot

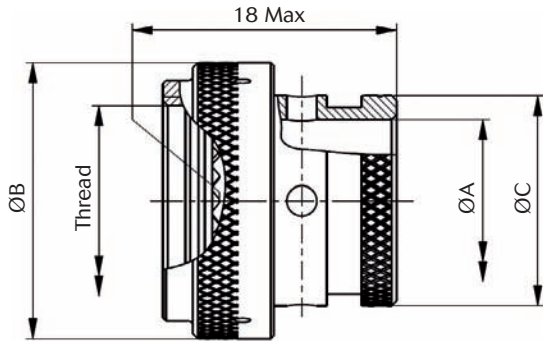

Shell size		ØA Min	ØB Max	C Max
8LT & 8D	8T			
09	08	6.7	19.0	11.3
11	10	9.95	21.5	14.9
13	12	12.85	25.3	17.8
15	14	16.05	29.1	21.27
17	16	19.2	31.7	24.3
19	18	21.5	35.5	26.4
21	20	24.7	39.3	30.8
23	22	27.8	41.8	34.1
25	24	31	46.9	36.6

Thread: See page 8 for information.

Aluminum backshell Type 04 - Crimp ring

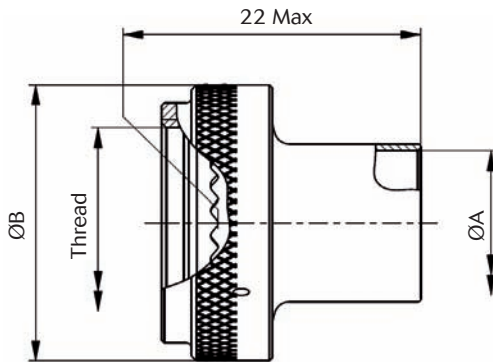

Shell size		ØA Min	ØB Max
8LT & 8D	8T		
09	08	6	17.9
11	10	8.2	20.9
13	12	10.5	24.3
15	14	13.6	27.9
17	16	16.9	31.3
19	18	20	34.3
21	20	23.2	38.1
23	22	26.1	41.5
25	24	28.1	44.4

Thread: See page 8 for information.

Aluminum backshell Type 05 - Band lock

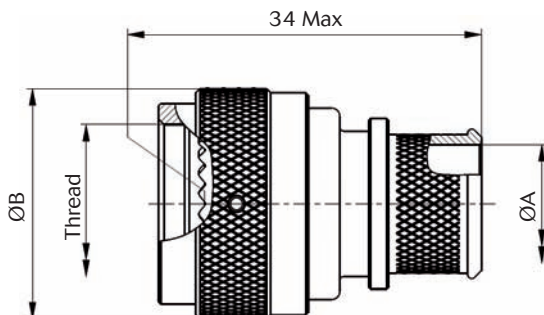

Shell size		ØA Max - Entry size		ØB Max
8LT & 8D	8T	01 (8LT & 8T) 02 (8D)	02 (8LT & 8T) 03 (8D)	
09	08	-	6.6	17.9
11	10	-	8	24.9
13	12	8	11.2	29.3
15	14	11.2	14.4	32.4
17	16	12.8	16	35.6
19	18	16	19.1	38.4
21	20	16	20.7	41.6
23	22	17.6	23.9	44.8
25	24	19.1	25.5	47.9

Thread: See page 8 for information.

Note: All dimensions are in millimeters (mm)

8LT, 8T & 8D Series Aluminum Backshells



Aluminum backshell Type 06 - Double cone

HE 308 standard - Screen termination and heat shrink boot

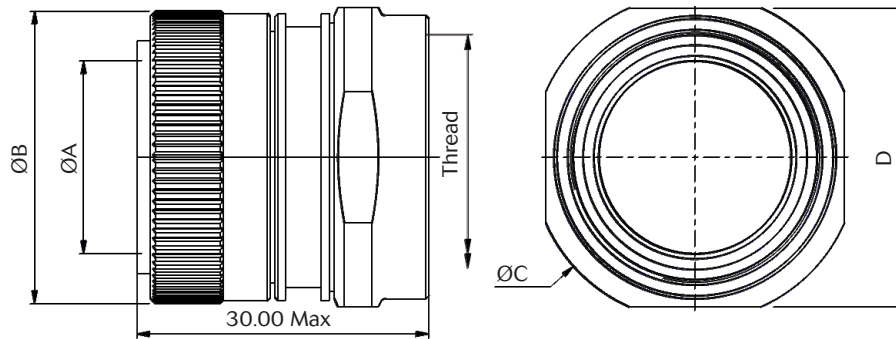

Shell size		ØA ^{±0.07}	ØB ^{±0.12}	ØC ^{±0.12}	D ^{±0.07}
8LT	8T				
09	08	7.1	15.55	19.35	16.7
11	10	10.25	18.45	23.35	20.7
13	12	13.05	21.85	25.35	22.7
15	14	15.25	25.05	28.35	25.7
17	16	18.45	28.05	31.35	28.7
19	18	20.65	31.05	34.35	31.7
21	20	23.85	34.45	38.35	35.7
23	22	26.95	37.45	41.35	38.7
25	24	30.15	40.75	44.35	41.7

Thread: See below for information.

Thread information

8LT & 8T Series

Shell size		UNEF Thread
8LT	8T	
09	08	7/16-28 2B
11	10	9/16-24 2B
13	12	11/16-24 2B
15	14	13/16-20 2B
17	16	15/16-20 2B
19	18	1 1/16 - 18 2B
21	20	1 3/16 - 18 2B
23	22	1 5/16 - 18 2B
25	24	1 7/16 - 18 2B

8D Series

Shell size	Metric Thread
09	M12x1.0-6H-0.10R
11	M15x1.0-6H-0.10R
13	M18x1.0-6H-0.10R
15	M22x1.0-6H-0.10R
17	M25x1.0-6H-0.10R
19	M28x1.0-6H-0.10R
21	M31x1.0-6H-0.10R
23	M34x1.0-6H-0.10R
25	M37x1.0-6H-0.10R

Note: All dimensions are in millimeters (mm)



8LT, 8T & 8D Series Aluminum Backshells

Recommended installation torque

Shell Size for 8LT, 8T & 8D	Installation Torque (Inch-Pounds)
08/09/A	40
10/11/B	40
12/13/C	40
14/15/D	40
16/17/E	40
18/19/F	40
20/21/G	80
22/23/H	80
24/25/J	80

Note: Torque values are based on 80% of the coupling thread strength specified in SAE-AS85049 standard.

Band-it

Designation	Flat stainless steel standard band	Pre-coiled stainless steel standard band	Hand banding tool
Part number	8599-9344	8599-9345	8599-9346

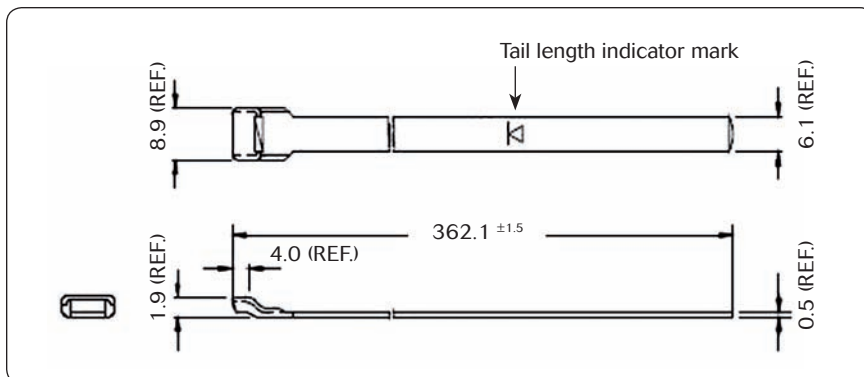

Note: All dimensions are in millimeters (mm)

8LT, 8T & 8D Series Aluminum Backshells



Band lock Type 05 assembly

Step 1: Prepare cable braid

Terminate wires to connector and screw the backshell to connector. Prepare the cable for termination process.

WARNING ! Banding must occur on an un-fixed cable assembly. Attaching a band to a firmly clamped cable will affect the applied forces and will also interfere with the cut-off operation. The cut-off operation causes a rotation of the band termination in order to lock the band.

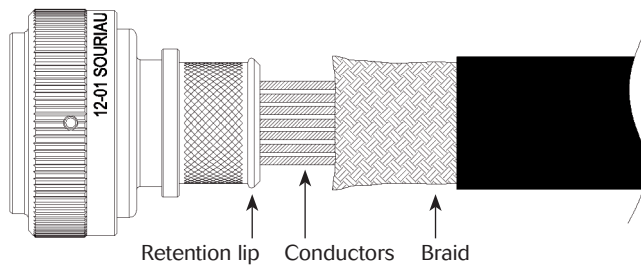

Step 2: Push braid over adaptor

Push the braid over the retention lip to the adaptor incline point or ensuring 10.2mm [0.4"] minimum braid length over termination area. Milk the braid as required to remove the slack and insure a snug fit around the shield termination area.

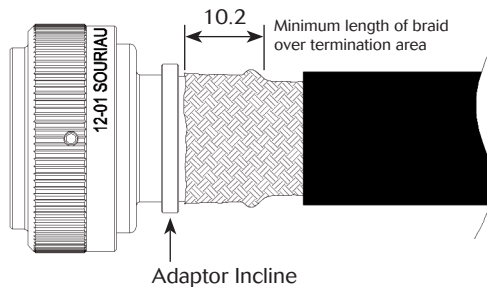

Step 3: Prepare band

Roll the band through the buckle slot twice. Pull on the band until the tail length indicator mark is within approximately 6.4 mm (0.250 in) of the buckle slot. The band may be tightened further if desired.

WARNING ! Always roll band through the buckle slot twice in order to ensure correct functioning.

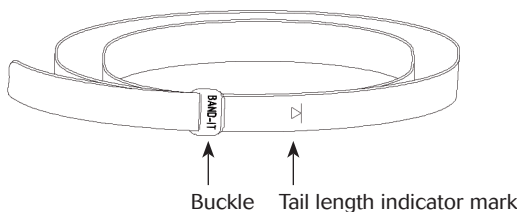

Step 4: Install band

a) Squeeze the gripper release lever of the banding tool and insert the band into the front end opening of the tool as shown on picture.

WARNING ! The circular portion of looped band must always face downward.



b) Aligning the band and the tool with the shield termination area, squeeze the black pull-up handle repeatedly using short strokes until it locks against the tool body (this indicates that the band is compressed to the tool pre-calibrated tension).

IMPORTANT ! Operator technique can affect the integrity of the band installation. The operator should use **abbreviated** or **partial** strokes of the pull-up handle as the band is pulling up against the braid. As the band becomes completely tight, apply a full strokes of the pull-up handle to ensure that the full calibrated force of the tool is applied as the handle locks into position.

c) Complete the clamping process by squeezing the gray cut-off handle, allowing the cable to rotate slightly during cut-off.

Step 5: Inspect the shield termination

Remove the excess band from the tool. Inspect shield termination. Install the heat shrinkable boot, if required.

WARNING ! Tools and Bands should never be lubricated.

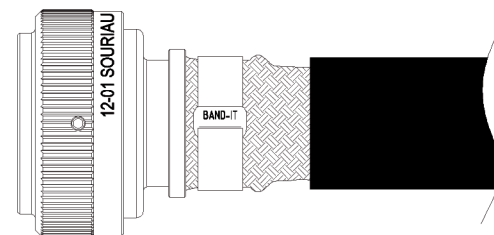

8LT, 8T & 8D Series Aluminum Backshells



Double cone Type 06 assembly

Step 1: Prepare cable braid

Prepare the cable for termination process and slide the backshell parts onto the cable the items in the order shown in above figure. Screw the backshell at the rear of the connector.

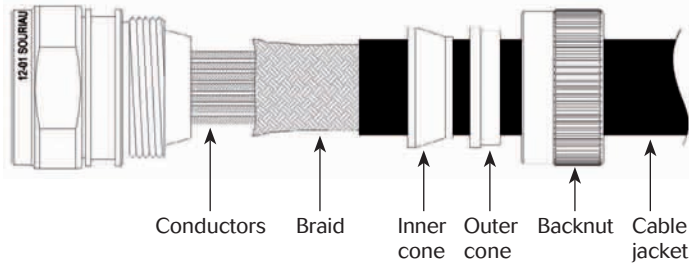

Step 2: Push braid over adaptor

Release the braid and slide the inner cone over the braid.

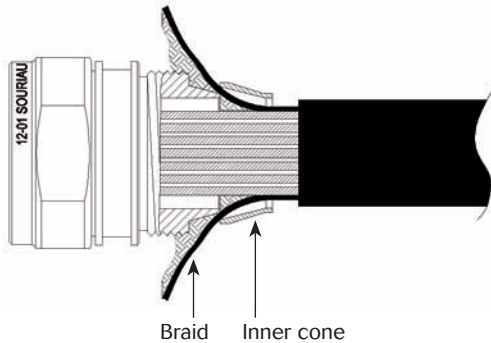

Step 3-a: Double folding

Fold back the braid on the inner cone and fix it with an adhesive tape on to the jacket of the cable. Slide the outer cone over the braid and the inner cone. Screw the backnut at the rear of the backshell and tighten it. Install heat shrinkable boot. Please refer to Step 3-b for alternate method (Single folding).

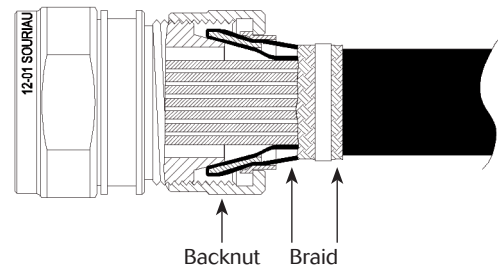

Step 3-b: Single folding

Cut the braid as shown. Slide the outer cone over the braid and the inner cone. Screw the backnut at the rear of the backshell and tighten it. Install heat-shrinkable boot.

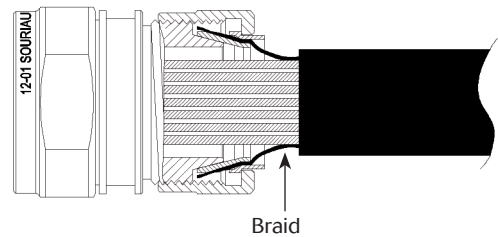

8D Series Aluminum Caps



Applications / Caps description



Metallic caps to protect plugs and receptacles from dust, moisture, contact bending, ...

Caps for plug

Olive drab cadmium, black anodized, nickel or black zinc nickel finish.
Rope available with ring or eyelet.
Thread stub ACME 2A modified 60°.



Caps for receptacle

Olive drab cadmium, black anodized, nickel or black zinc nickel finish.
Rope available with ring or eyelet.
Thread stub ACME 2B modified 60°.

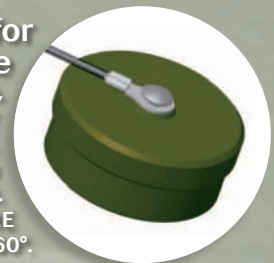

Ordering information

Aluminum caps for 8D Series

Basic Series	8D	AC	5	R	09	W
Accessories style:						
AC: Aluminum caps						
Caps style:						
5: Plug caps						
0: Receptacle caps						
Accessories:						
N: With stainless steel rope and ring						
R: With stainless steel rope and eyelet						
Shell size:						
09, 11, 13, 15, 17, 19, 21, 23, 25						
Finish:						
W: Olive drab cadmium						
F: Nickel						
Z: Black zinc nickel						
A: Black anodized						

8D Series Aluminum Caps



Dimensions

Aluminum caps with stainless steel rope

For plug

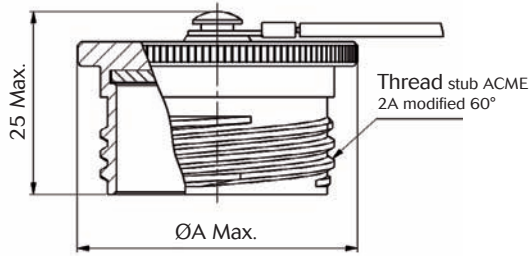

For receptacle

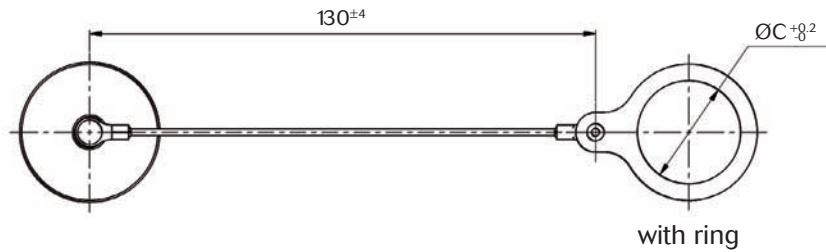
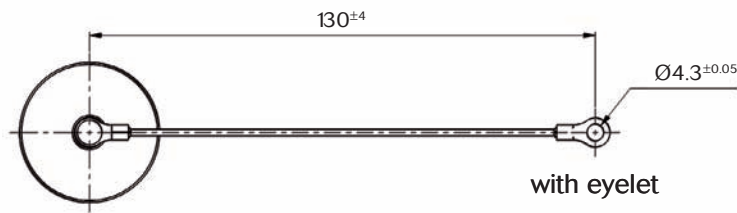
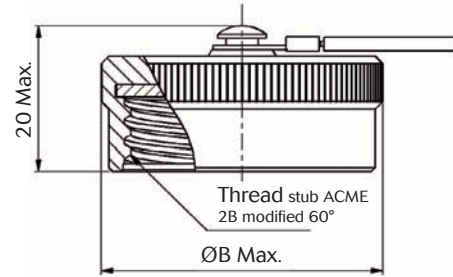

Size	ØA	ØB	ØC		Thread
			for plug	for receptacle	
09	22.6	22.8	15	18.4	0.6250-0.1P-0.3L-TS
11	25.8	26.5	18.4	23.2	0.7500-0.1P-0.3L-TS
13	30	30	23.2	26.5	0.8750-0.1P-0.3L-TS
15	33	31.8	23.2	30.3	1.0000-0.1P-0.3L-TS
17	36.5	36.8	26.5	32.6	1.1875-0.1P-0.3L-TS
19	39.2	38.8	30.3	36.5	1.2500-0.1P-0.3L-TS
21	42.5	41.8	32.6	39.3	1.3750-0.1P-0.3L-TS
23	45.8	44.8	36.5	42.9	1.5000-0.1P-0.3L-TS
25	48.9	48.8	39.3	45	1.6250-0.1P-0.3L-TS

Note: All dimensions are in millimeters (mm)

8LT, 8T & 8D Series

Aluminum Backshells & Caps



Comparison of plating codes available on the market

Requirement	Electroless Nickel	Cadmium	Black Anodize	Zinc Nickel Black	Others		
					Nickel PTFE		Pure Electro Deposited Aluminum
					Thick	Thin	
Finish code class per MIL spec.	N	W	A	Z	T		P
RoHS Compliant	✓	No	✓	✓ ⁽¹⁾	✓	_ ⁽⁸⁾	_ ⁽⁹⁾
Galvanic compatibility with cadmium	Poor	Very good	Good	Good ⁽²⁾	Poor ⁽³⁾	Poor ⁽³⁾	Good
Easy to produce in mass production & with multi sourcing	✓	✓	✓	✓	No ⁽⁴⁾ (10)	No ⁽⁴⁾ (10)	No ⁽⁵⁾
Finish according to standard	ASTM B733	ASTM B766	Class-2 AMS-A-8625	ASTM B841	No standard ⁽⁶⁾ proprietary process	No standard ⁽⁶⁾ proprietary process	No standard ⁽⁶⁾ proprietary process
Conductivity < 2.5 mΩ	✓ <1 mΩ	✓	No	✓	✓	✓	✓
Durability (500 mating cycles)	✓	✓	✓	✓	✓	✓	_ ⁽⁷⁾
Dynamic salt spray resistance	96 hours	1000 hours	500 hours	1000 hours	1000 hours	1000 hours ⁽⁸⁾	1000 hours ⁽⁷⁾
Temperature rating	according to standard 175°C	✓	✓	✓	✓	✓	✓
	200°C	✓	No	No	✓	✓	✓
Not Reflective	No	✓	✓	✓	✓	✓	✓
Non-Magnetic	✓	✓	✓	✓	✓	✓	✓
Cr6+ < 0.01 % (RoHS limit = 0.1 % max)	✓	No	✓	✓	✓	_ ⁽⁸⁾	_ ⁽⁹⁾
Easy to check homogeneity / Thickness of layer	✓	✓	✓	✓	No ⁽¹⁰⁾	No ⁽¹⁰⁾	✓
Environment friendly	Poor	Poor	✓	Good	Poor ⁽¹¹⁾	Poor ⁽¹¹⁾	-
Human health and safety	✓	Poor	✓	✓	Poor ⁽¹²⁾	Poor ⁽¹²⁾	Poor ⁽¹³⁾
Compatibility with new de-icing fluid (with potassium acetate)	✓	✓	✓	✓ ⁽¹⁴⁾	_ ⁽¹⁴⁾	_ ⁽¹⁴⁾	_ ⁽¹⁴⁾

See next page for notes explanation.

8LT, 8T & 8D Series

Aluminum Backshells & Caps



1 SOURIAU Zinc Nickel (Z code) and RoHS

A unique SOURIAU plating process compliant with RoHS regulation for Cadmium and Cr6+ restriction.

2 Electrical compatibility of Zinc Nickel (Z code) with Cadmium (W code)

Electrical potential of Zinc Nickel and Cadmium are very similar which removes the risk of galvanic corrosion and defects after 500 hours salt spray.

3 Electrical compatibility of Nickel PTFE (T code) with cadmium (W code)

PTFE is an inert polymer, therefore the galvanic potential of Nickel + PTFE will be the potential of the Nickel alone. It means that the electrical compatibility is not guaranteed between Nickel PTFE and Cadmium for long salt exposure, which is not the case for Zinc Nickel (electrical potential close to Cadmium).

4 Nickel PTFE (T code) production processes complex and expensive

Nickel PTFE requires specially manufactured high tolerance machined parts (special requirement on surface roughness) as the thicker plating is not compatible with standard machined parts.

- These special machined parts lead to a higher cost and quality risk (mixing very similar parts and special care in case of outsourcing).
- Therefore, the high thickness of nickel PTFE means a long deposit time and also a more expensive process.
- The lifetime of the chemical mixture is half than an electrolytic nickel or nickel alloy (Zinc Nickel) mixture.

5 Pure Electrodeposited Aluminum (P code) very complex and unique deposition process

Very complex and explosive process which requires a building with special containment facility and not available in standard plating shops. Main limitation are the following:

- Flammable and explosive solvent which requires inert atmosphere.
- Highly skilled worker (expertise and training)
- Specific care for handling and storage of mixture in a separate building.

6 ASTM standards

These standards are defined to allow a reliable quality level of plating process with multisourcing option. Nickel PTFE (T code) and Pure Electrodeposited Aluminum (P code) are not defined by ASTM industrial standards.

7 Cycles of durability, limitation for Pure Electrodeposited Aluminum (P code)

Performance limitation has been raised in 38999 dynamic salt spray by tests against Pure Electrodeposited Aluminum:

- Galling: abrasive wear of Ni-plated EMI band leads to generate conductive particles with a potential risk of short circuiting the contacts.
- Requires use of lubricants - limited effectiveness, risk of lower electrical continuity.

8 Thin Nickel PTFE (T code) salt spray resistance

Thin Nickel PTFE (T code) could require Cr VI to meet corrosion performance and consequently not comply with ROHS limit.

This is one way to heal pores at defect sites of the primary parts and to decrease the production cost of the thick Nickel PTFE plating (see note 4).

9 Pure Electrodeposited Aluminum (P code) and Chromium VI

Chromium VI is required to meet high corrosion performances.

10 Thickness control of Nickel PTFE layer (Thin and Thick Layer)

There is no standard in line equipment to control the homogeneity of PTFE concentration within the plating material and the only way to control the PTFE concentration is achieved with complex lab equipment such as Scanning Electron Microscope (PTFE is a non conductive material).

There is consequently a strong limitation for in line process control and ability to outsource. It means that the lack of control associated with the risk of non homogeneity of the PTFE concentration could lead to an uncontrolled dormant failure and a rapid corrosion.

11 Environment friendly, limitation for Nickel PTFE (T code)

The average bath lifetime of the chemical nickel PTFE is half that of electroless nickel and 10 times less than nickel alloy (zinc nickel) bath. This leads to a higher waste volume of nickel pollution. Furthermore, the waste toxicity of electroless nickel or nickel alloys is higher than the electrolytic process:

- Toxicity level ↑
- Cadmium
 - Nickel electroless
 - Nickel PTFE
 - Electrolytic zinc nickel

In addition, the PTFE material is toxic and indestructible.

Some PTFE suppliers might stop their PTFE production after 2013 (ie. Dupont)

12 Nickel PTFE (T code) is potentially hazardous to human health

The Nickel PTFE material is recognized as toxic and indestructible. Most of the experts are considering PFOA (used in PTFE) a «likely human carcinogen». This was also proposed by the Environmental Protection Agency (EPA).

13 Pure Electrodeposited Aluminum (P code) process is very hazardous to safety

For Pure Electrodeposited Aluminum, production is a very high risk for human safety due to:

- Flammable and explosive solvent which requires inert atmosphere.
- High skilled of workers necessary (expertise and training).
- Specific care for handling and storage of mixture in a separate building.
- Pure Electrodeposited Aluminum is considered as a dangerous explosive process for people involved in the plating process.

14 De-icing fluid (contains potassium acetate)

SOURIAU Zinc Nickel is compatible with de-icing fluids containing potassium acetate.

No datas found regarding Nickel PTFE or Pure Electrodeposited Aluminum.

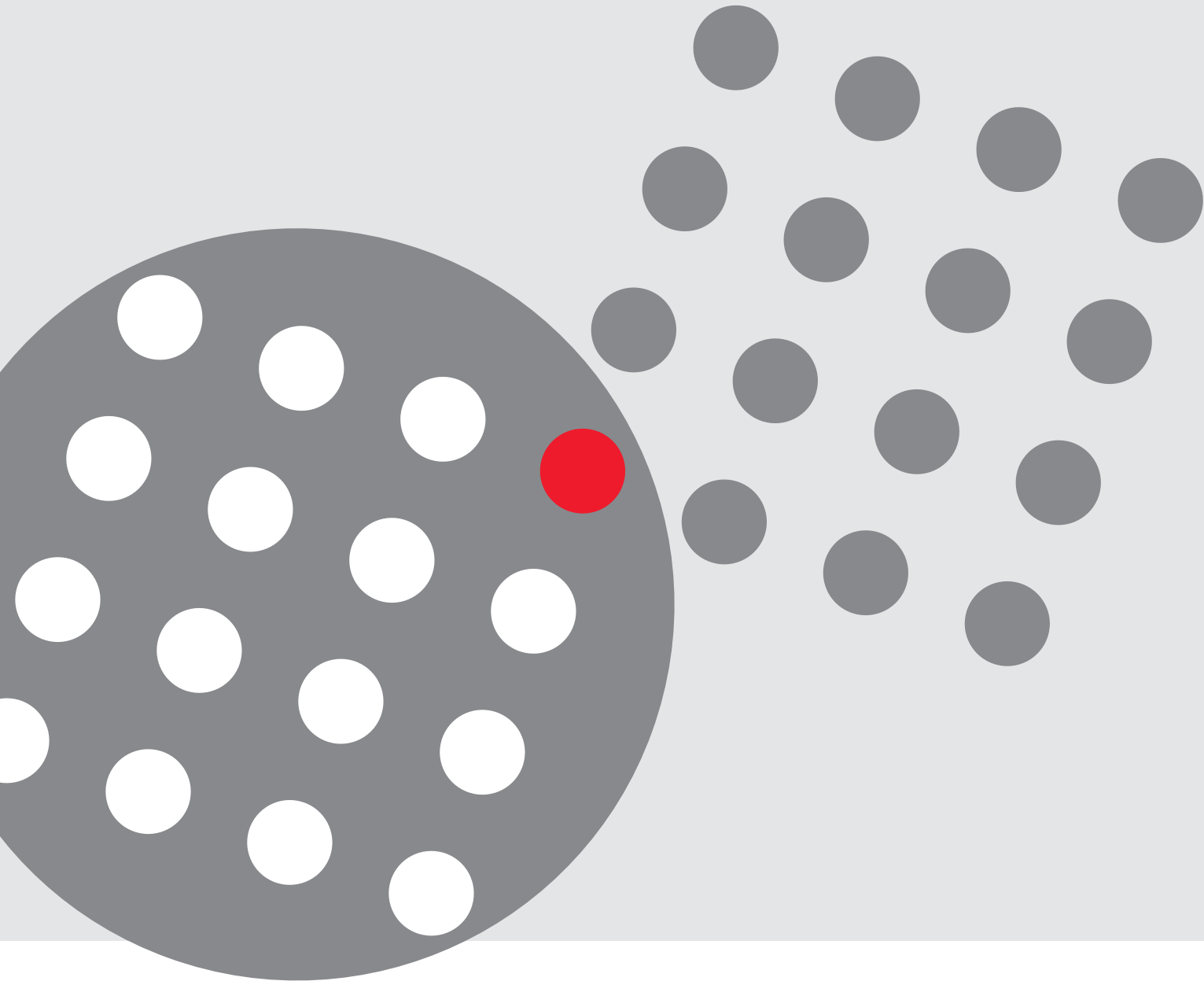

SOURIAU

www.souriau.com

contactmilaero@souriau.com

