

A complete range for metering, monitoring & power quality

2015
2016



socomec
DIRIS Digiware D-50
ALARM COM ON

+ FREQUENCY I
CLIM BAT ID: 6CAB0B

U 398.5v	U 398.4v
1-2 05.03.2014 11:10:00	2-3 05.03.2014 11:10:00

AVG MAX
U 398.5v F 50.01 HZ
3-1 05.03.2014 11:10:00

IP E [Home] [Left] [Right] [OK]
VF [Up] [Down] [Left] [Right]

socomec
DIRIS Digiware U-30
ON ALARM COM ID: 345878

socomec
DIRIS Digiware I-35
ON ALARM COM ID: 345878

socomec
DIRIS Digiware I-35
ON ALARM COM ID: 345878

MAKE BUS

3x30 (10/10/10) 1P/3W

Network switch rack with blue Ethernet ports and grey patch panel.

Contents

The SOCOMEC Group p. 4 to 11

Why choose SOCOMEC? p. 14

DIRIS Digiware - Build your own system p. 16

Multi-circuit metering & measurement

 **new**
DIRIS Digiware
p. 20

 **new**
TE / TR / TF
current sensors
p. 32

Measurement and wireless metering

 **new**
DIRIS B-30
p. 26

 **new**
TE / TR / TF
current sensors
p. 32

Single-circuit metering, measurement & analysis

 *COUNTIS E*
p. 36

 *DIRIS A*
p. 54

 *DIRIS N*
p. 88

Metering and measurement for data centres

 **new**
DIRIS BCMS 720
p. 116

Communication gateways

 **new**
DIRIS G
RS485 and wireless to
Ethernet
p. 124

 **new**
DATALOG
H40/H60
p. 128

 **new**
Wireless communication
gateways
p. 132

 **new**
Communication
accessories
p. 136

Measurement devices

 Current
transformers
5 to 6000 A
p. 96

 Measurement
shunt
p. 112

 Other solutions
1 to 6000 A
p. 114

Software suite

Embedded web server

 **new**
VERTELIS
WEBVIEW
p. 138

Energy Management
Software

 **new**
VERTELIS
HYPERVIEW
p. 140

Management software for
COUNTIS and *DIRIS*

 p. 142

Indicators and transducers

 AC
measurements
p. 122

 Digital
meters
p. 122

An independent manufacturer

The benefit of a specialist

3,500 m²
of test platforms

One of the leading independent power testing labs in Europe

50,000
on-site interventions per year

Nearly 400 experts in commissioning, technical audit, consultancy and maintenance

10%
of turnover invested in R&D

Always at the cutting-edge of technology for innovative, high-quality products



SO innovative!

Since its foundation more than 90 years ago, SOCOMEC continues to design and manufacture its core products in Europe. Notably solutions for its primary mission: the availability, control and safety of low voltage electrical networks.

As an independent manufacturer, the Group is committed to constant innovation to improve the energy performance of electrical installations in infrastructures as well as industrial and commercial sites.

Throughout its history, SOCOMEC has constantly anticipated market changes by developing cutting-edge technologies, providing solutions that are adapted to customer requirements and fully in keeping with international standards.

"Optimising the performance of your system throughout its life cycle" - this is the commitment carried out every day by the SOCOMEC teams around the world, wherever your business is located.

SYDV 181 A



Four key applications: the know-how of a specialist



Critical Power

Ensuring the availability of high-quality power for critical applications.

Thanks to the company's wide range of continuously evolving products, solutions and services, SOCOMEC are experts in the three essential technologies that can ensure the high availability of supply to critical facilities and buildings i.e.:

- uninterruptible power supplies (UPS) that provide high-quality power and reduce

distortion and interruptions to the mains supply due to their power storage backup,

- changeover of high availability sources to transfer supply to an operational backup source,
- continuous monitoring of installation facilities to prevent failures and reduce operating losses.



© Datadock



Power Control & Safety

Managing power and protecting individuals and property.

SOCOMECS expertise in this domain is unquestionable; the company is an undisputed leader in power switching and changeover functions, and has been a specialist manufacturer of electrical equipment since 1922. The company has long defended the benefits of fuse protection for individuals and

property, and has become a major player in cutting-edge technology such as the monitoring and detection of insulation defects. SOCOMEC guarantees solutions and services which are both relevant and efficient.



APPLI 575A



Solar Power

Guaranteeing the safety and durability of photovoltaic (PV) facilities.

As experts in the solar energy equipment field, SOCOMEC has all the specialist know-how for implementing key strategic functions in on-grid and off-grid PV facilities, including:

- safety, through specially designed switch disconnectors to cut the DC current generated by solar panels regardless of the facility configuration and operating conditions,
- the reliability of DC facilities thanks to solutions preventing the degradation

of insulation and electric arc failure in DC current,

- control of very high-efficiency energy conversion, via PV inverters, to transform all energy generated by the solar panels into power to be consumed locally or re-injected into the national grid,
- PV production and energy storage solutions for on-grid and off-grid applications.



COFFO 413 A



Energy Efficiency

Improving building and facility energy efficiency.

SOCOMECS solutions, ranging from sensors to the wide choice of innovative, modular software packages, are driven by experts in energy efficiency. They meet the essential requirements of managers or operators of tertiary, industrial or local authority buildings, and make it possible to:

- measure power consumption, identify sources of excess consumption, and raise occupant awareness,

- limit reactive energy and prevent associated tariff penalties,
- use the best tariffs, check supplier invoicing and accurately distribute energy bills amongst consumer entities.



APPLI 571A

Services & Technical Assistance

the manufacturer's guarantee

Over several decades, SOCOMEC Systems have acquired a distinguished reputation in the control, safety and performance of low voltage electrical distribution equipment. Our manufacturer's expertise naturally extends to a complete offer of services designed to help you select, implement and get the most out of our solutions.



APPLI 586 A

Specially adapted skills

Our service team consists of field personnel specialising in our specific domains and experienced in the maintenance of industrial electrical systems. This means you benefit from a dual skills base:

- technical expertise relating to the products that have been installed,
- practical knowledge of your usage needs.

Reassuringly close at hand

Our geographical coverage means that we are close to each user and can respond quickly to all requests. We can provide a complete service from the technical diagnostics before repair right up to implementation of the most suitable solutions for your installation.

Customer-oriented service

True to our own principles, we encourage direct and friendly contact. Our interventions offer solutions targeted to a single problem: Yours. Our engineers are always very attentive to your needs, to ensure that we provide the most relevant technical support and advice. So you can plan your investments with confidence.

Customised support...

Assessment and sizing

Depending on your requirements, our experts collect and analyse all the relevant data in order to recommend the system best adapted to your installation.

Commissioning

Installation of your equipment is carried out by a specialist, and is totally compatible with and adapted to your use.

Maintenance

A wide range of preventive or corrective maintenance options designed to suit your installation and its environment, and to ensure continuity of service of your electrical networks.

Training

You will receive training, specially adapted to your needs, in order to familiarise yourself with our equipment and enable you to use it to your best advantage.



... to ensure you a successful project

■ Source inversion in complete safety

Changeover switches are strategic components that ensure continuity of service of supplies. In order to guarantee **complete operational safety**, we will implement our range of innovative source transfer solutions.

■ Your energy consumption efficiently and comprehensively managed

Monitoring of energy consumption within a production unit is one of your primary operational considerations. From the preliminary assessment of your installation to the adaptation of the software, dedicated SOCOMEC experts are on hand to assist you throughout the entire energy performance process.

■ Effective insulation monitoring for your electrical installation

To ensure that your fault monitoring and location system operates to its optimum capacity, our team of specialists perform all operations on site.

This means that you benefit from renowned expertise, as well as solutions tailored to the specific monitoring requirements of your electrical installation.

■ The control of reactive energy on your electricity bill

In terms of power factor correction, **the support of a specialist is essential to appropriately size your system** and meet the desired efficiency.

SOCOMECC will help you to make the right choices and therefore to benefit from a long-term solution. A real return on investment.

For more information, please see pages "Reactive energy power factory correction".



CORPO 164 A



APPLI 540 A

A cutting-edge laboratory

The backing of an expert

Since 1965, the Pierre Siat test laboratory has used its expertise to guarantee the reliability and conformity of SOCOMEC products and solutions. Our customers are also welcome...

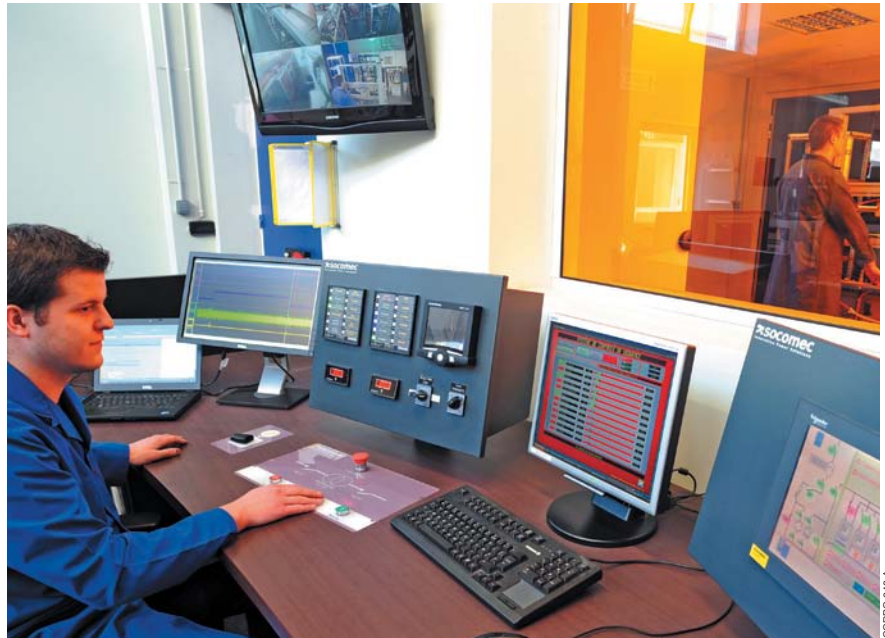

COPEO 342 A

A decisive link

Located at the Company's headquarters in Benfeld (France), the Pierre Siat test laboratory is one of SOCOMEC's main quality pillars: its contribution to the development, qualification and certification phases plays a decisive role in the process leading to the creation of a product or solution.

Global scale

This totally independent laboratory is recognised by the major certification bodies worldwide: a member of the ASEFA⁽¹⁾ and the LOVAG⁽²⁾, it is accredited by COFRAC⁽³⁾, UL (CTDP⁽⁴⁾), CSA (shared certification) and KEMA (SMT/WMT⁽⁵⁾). It also works in partnership with numerous international certification organisations⁽⁶⁾. The quality and safety requirements specific to each country are therefore fully taken into account.

Specialist facilities

With its 100 MVA (Idc 100 kA rms 1 s) short-circuit platform, three 10 kA overload platforms and numerous other test instruments in facilities covering 1500 m², the Pierre Siat laboratory is currently the 2nd French power laboratory. It combines expertise in electricity and mechanics, pneumatics and computing.

Ongoing commitment

To adapt to the increasingly demanding standards and ever more innovative and high-performance products, the Pierre Siat laboratory is permanently extending the scope of its tests, investing whenever necessary in new equipment.

A vast range of tests

The laboratory submits all SOCOMEC products and solutions (including those in enclosures) to numerous tests in the following fields:

- functional: component resistance and operating tests,
- dielectric: immunity to interference, dielectric insulation, overvoltage, overcurrent,
- mechanical: endurance and mechanical shocks, etc.,
- environment: functional or electrical tests under extreme conditions (temperatures, salt spray, etc.), vibrations,
- AC/DC endurance: in operation and under controlled temperatures (arcs, LV/HV power cuts, etc.),
- temperature rise,
- electromagnetic compatibility (EMC),
- metrology,
- safety: flammability, etc.

Conducted during the design and production phases, these tests guarantee the long-term reliability of the equipment sold.

Customized services

These test facilities and expertise are also available to our partners who require assistance with the qualification and certification of their products or equipment.



We issue certificates of conformity and performance declarations upon request.

For more information, visit our web site: www.socomec.com/testing-laboratory_en.html

- (1) Association des Stations d'Essais Françaises d'Appareils électriques basse tension (French association of low voltage electrical equipment test stations)
- (2) Low Voltage Agreement Group
- (3) Comité Français d'Accréditation (French accreditation body)
- (4) Client test data programme
- (5) Supervised Manufacturer's testing/Witnessed manufacturer's testing
- (6) KEMA, CEBEC, UL, CSA, ASTA, Lloyd's Register of Shipping, Bureau Veritas, BBJ-SEP, EZU, GOST-R, etc.



For a high quality power supply

innovative power solutions

Critical equipment requires high quality energy and faultless continuity of the power supply. Our uninterruptible power systems (UPS), static transfer systems (STS), and DC/AC and AC/DC converters (inverters and rectifiers, respectively) comprise the most complete ranges in the world and cover a very wide range of applications for every sector of activity.



- > Uninterruptible power systems (UPS)
- > Static transfer systems (STS)
- > Rectifier chargers
- > DC/AC converters (inverters)
- > Energy storage systems
- > Harmonic compensators
- > Communication interfaces and software
- > Commissioning Inspection and Maintenance



High availability

The availability of electrical energy is a strategic factor in a range of industries as varied as telecommunications, data processing centres or some industrial processes. It is sometimes vital for certain medical applications. In all these sectors, SOCOMEC can put over 45 years of experience at your disposal.

Product solutions that meet requirements

Underspinned by significant R&D resources, our product offer continually evolves as a consequence of our contact with customers. Our products have gained approval from the most demanding of users: telecoms operators, the nuclear industry, naval industry etc.

Recognised expertise

Our users' needs are at the forefront of everything we do, as demonstrated by the prestigious distinctions that SOCOMEC and its UPS solutions have received:

- customer service excellence award (2004),
- product innovation award (2006),
- award for the best product offer (UPS) in Europe (2009),
- award for innovation in new UPS (2011).

Continuing innovation

The constant search for innovation is hardwired into SOCOMEC's approach to technology:

- first French manufacturer to offer static power systems (1968),
- first UPS to use PWM technology (1980),
- first range of high power UPS with IGBT technology (1996),
- first modular, upgradeable and redundant UPS (2000),
- first manufacturer to integrate hybrid components (2001),
- first 200 kVA UPS with IGBT rectifier (2003),

- new battery charging concept (2004),
- dynamic energy storage system / Flywheel (2006),
- first UPS with 96% efficiency in true online double conversion mode (2007),
- the most compact STS, in a 19" hot-swappable rack version (2009),
- most compact 900 kVA UPS (2010),
- first complete UPS range (10-2400 kW/kVA) with 3-level technology, 96% efficiency and power factor 1 (2012).

Customer-oriented service

Our sales and after-sales network means we are always there for you. Our partner-customers recognise the quality of our products, availability and flexibility in meeting requirements and commitment.





- 1 Find out about products, services and systems meeting the requirements of applications for which we have a real expertise
- 2 Download documentations, pictures, logos and CAD files
- 3 Find and contact the nearest Socomec contact
- 4 Find answers to technical questions (FAQ)
- 5 Find out about our job offers
- 6 Get informed about our news: products, events and advice



Find out more on



100% mobility

Access multimedia contents from your smartphone by scanning the codes available in our catalogues or documentations.

How?

1. Download

a QR code application from your mobile phone (QR Code Scanner Pro, Mobiletag, ScanLife flashcode, etc.).

2. Scan



3. Browse!

A few examples:



Flash banner for ATyS transfer switch

FLCD_URL_048_A_GB



Download section on the Socomec website

FLCD_URL_004_A_GB

Banners Software
Selection guides **Photos**
Brochures Videos
User guides **Tutorials**

Application Guide

Monitor your electrical installation

The basic information for controlling and protecting an electrical installation in just a few mouse clicks!

The Socomec Application Guide is regularly updated and incorporates all the experience and know-how of our specialist engineers.



CORPO 288A

Download the Application Guide



FLGD_URL_010_A_GB

www.socomec.com/application-guide-scp_en

Contents

- L.V. distribution
- Overload currents
- Short circuit currents
- Direct and indirect contact
- Voltage drops
- Switching and isolating devices
- Fuse protection
- Control and energy management
- Industrial communication networks
- Electrical measurement
- Digital protection of networks
- Differential protection
- Insulation Monitoring
- Overvoltage limiter
- Surge arresters
- Reactive energy power factor correction
- Enclosures
- Busbars
- Uninterruptible Power Systems (UPS)

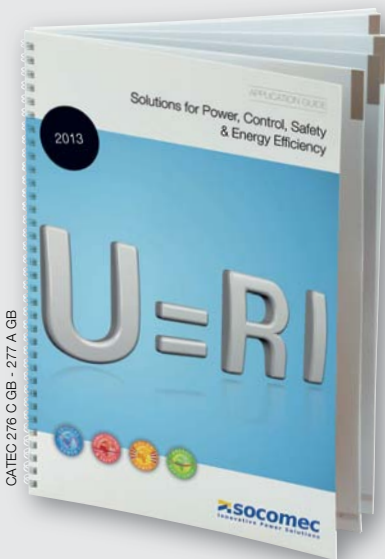

CATEC 276 C GB - 277 A GB

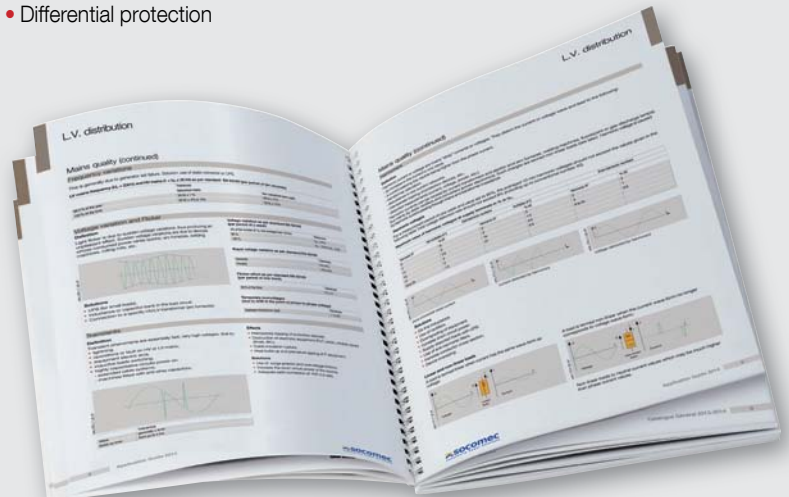

Alphabetical index

A	
Analogue meters _____	122
C	
Communication accessories _____	136
COUNTIS and DIRIS management software tools _____	142
COUNTIS E0x _____	38
COUNTIS E1x _____	40
COUNTIS E2x _____	42
COUNTIS E3x _____	44
COUNTIS E4x _____	46
COUNTIS E5x _____	48
COUNTIS E63 _____	50
COUNTIS ECix _____	52
Current transformers _____	98
D	
Datalogger _____	128
Digital meters _____	122
DIRIS A10 _____	56
DIRIS A14 _____	60
DIRIS A17 _____	64
DIRIS A20 _____	68
DIRIS A40/A41 _____	72
DIRIS A60 _____	78
DIRIS A80 _____	84
DIRIS B-30 _____	26
DIRIS BCMS 720 _____	118
DIRIS Digiware _____	20
Build your own system _____	17
DIRIS G _____	124
DIRIS N300/N600 _____	88
H	
Hour counters _____	122
M	
Measurement shunts _____	112
Modular transducers _____	122
O	
Other electrical measurement devices _____	122
Other products, measurement devices _____	114
P	
PTI: CT automatic short-circuiter _____	114

R

Radio communication interfaces _____ 132

S

Selection guide

COUNTIS E _____ 36
Current transformers _____ 96
DIRIS _____ 54
DIRIS BCMS 720 _____ 116
DIRIS Digiware _____ 18
Selector switches _____ 122
Sensor PT100 - screw type _____ 115

T

TE, TR and TF current sensors _____ 32
Transducers _____ 122
Transformer with integrated converter (CTA-VA) _____ 115

V

VERTELIS HYPERVIEW _____ 140
VERTELIS WEBVIEW _____ 138
Voltage transformer BTV 25 _____ 115

W

Why choose SOCOMEC? _____ 14



Why choose SOCOMEC?

Metering, monitoring & power quality

Innovative and high performance solutions manufactured by specialists in electrical energy management

A leader in Energy & Power Management

- With the COUNTIS E, DIRIS A and associated current sensor ranges, SOCOMEC has developed one of the most advanced multifunction measurement ranges on the market, dedicated to improving your energy performance.

A monitoring device specialist

- The DIRIS G communication gateways and DATALOG H dataloggers centralise measurement data via wire or radio link.
- Web server solutions embedded in the DIRIS A and DIRIS G products enable the real-time monitoring of electrical parameters and alert users in case of anomaly.

Experts in energy performance analysis

- VERTELIS Suite software analyses multi-utility energy data in order to reduce energy consumption.
- VERTELIS HYPERVIEW offers a wide range of tools for raising user awareness of energy consumption, creating reports and for dashboard display.



Metering

DIRIS Digiware Multi-circuit Power Monitoring Devices



COUNTIS E Single-circuit Energy meters



Measurement

DIRIS Digiware Multi-circuit Power Monitoring Devices



DIRIS A Single-circuit Multifunction meters



DIRIS B Wireless Power Monitoring Device



DIRIS BCMS 720 Branch Circuit Monitoring System for data centres



Power Factor Correction

COSYS PFC Power Factor Correction without harmonic protection



**Power Factor Correction with harmonic protection
COSYS PFC**



An independent partner working closely with our customers



Ranges that combine performance and quality

The DIRIS A and DIRIS Digiware ranges are compliant with the latest IEC 61557-12 standard dedicated to multi-measurement devices (PMD*). The COUNTIS E range complies with the requirements of the latest MID** directive (B+D module).

* Performance Measuring and Monitoring Devices.
** MID: Measuring Instruments Directive.

Customised support and partner proximity

Our manufacturer's expertise naturally extends to a complete offer of services. From the required preliminary assessment of your installation via in-depth analysis and application of the data, through to software adaptation and training, the experts at SOCOMEC provide customers with support in improving their energy efficiency and reaching energy performance targets.

Data centralisation

DIRIS G communication gateways



DATALOG H Dataloggers



Monitoring

VERTELIS WEBVIEW web server



WEBVIEW is embedded in the DIRIS G communication gateway.



Analysis

VERTELIS HYPERVIEW software



HYPERVIEW is hosted on a local or remote (Cloud) server.





DIRIS Digiware

Multi-circuit metering & measurement

An energy measurement and monitoring system that revolutionises electrical installations

- 1 display
- 1 voltage measurement module
- current measurement modules
- current sensors

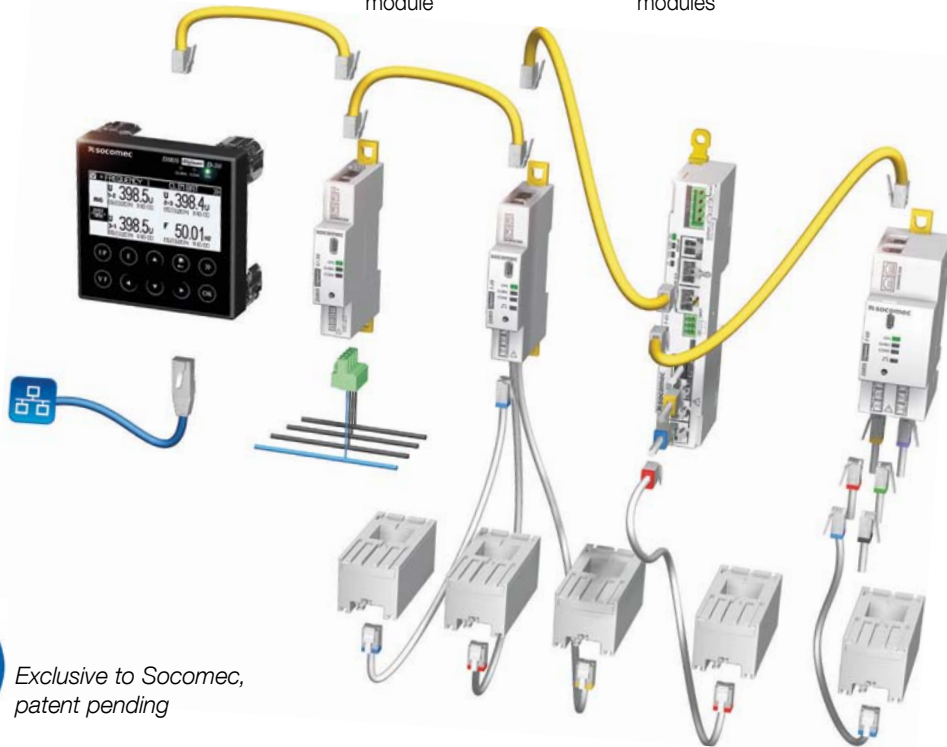

Exclusive to Socomec, patent pending



Flexible

Shared functions:

- Common display.
- Single voltage measurement for the entire system.
- Single auxiliary power supply.

Installation of components close to the load

- Modules and sensors can be installed at the closest point to the values to be measured.
- Elimination of hazardous voltage on panel doors.

Compact design

- Compact voltage and current modules (1 to 2 modules).
- System suitable for new and existing or installations including panels with space restrictions.

Large range of current sensors

- Flexible, solid or split-core current sensors.
- Various dimensions and types.
- Numerous accessories allow the system to be installed in all panel configurations.



Multi-circuit

Ability to monitor several circuits via a single current measurement module due to independent current inputs.



Accurate

Accuracy of measurements guaranteed according to IEC standard 61557-12:

- Class 0.5 from 2% to 120% of nominal current for the global measurement chain (associated with TE/TF current sensors).
- Class 0.2 for the meter alone.



Cost-effective

- Implementation in a quarter of the time vs existing technologies.
- Save space in panels.
- Common voltage measurement functions, display and communication.
- Up to 30% saving compared to existing metering technology.



Plug & Play

RJ12 current sensor connection

- Rapid: automatic detection of ratings and verification of current direction.
- Reliable: identification of cables by color-coding and wiring control by product.
- Safe: disconnection of the current sensor secondary under load.

RJ45 interconnection of modules (Digiware bus)

- Rapid: a single connection, no tools required.
- Intelligent: allows communication and interaction between various modules.
- Reliable: ensures auxiliary power supply to modules without the risk of disconnection.

Auto-configuration of parameters

- Network type.
- Load type.
- Addressing of devices connected to the bus.

Build your own system



Control and power supply interface (24 VDC) Voltage measurement module Current measurement modules

DIRIS Digiware D with display **DIRIS Digiware C** without display **DIRIS Digiware U-x** **DIRIS Digiware I-3x** 3 inputs **DIRIS Digiware I-4x** 4 inputs **DIRIS Digiware I-6x** 6 inputs

Current sensors Communication gateway

TE Solid **TR** Split-core **TF** Flexible **DIRIS G** RS485 and/ or wireless to Ethernet **DIRIS D-90** Touch-screen tablet that can be fitted on the panel door

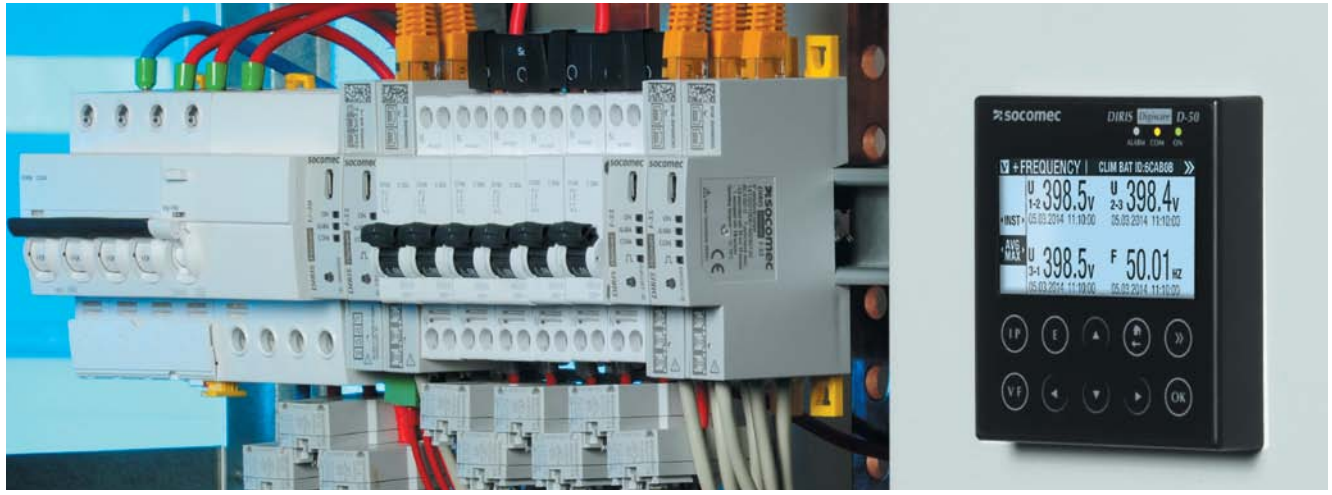



Selection guide



Measurement and monitoring system for electrical installations

DIRIS Digiware

Multi-circuit metering
& measurement

new



Application	Voltage measurement module		
	Metering	Monitoring	Analysis
			
DIRIS Digiware U	U-10 <i>p. 20</i>	U-20 <i>p. 20</i>	U-30 <i>p. 20</i>
Multi-measurement			
U12, U23, U31, V1, V2, V3, f	•	•	•
U system, V system			•
Ph/N unbalance			•
Ph/Ph unbalance			•
Power quality			
THDv1, THDv2, THDv3, THDu12, THDu23, THDu31		•	•
Individual harmonics U & V (up to rank 63)			•
Voltage dips, interruptions and swells (EN 50160)			•
Alarms			
On threshold			•
History of average values			
45 days (max.)			•
Format			
Width/Number of modules	18 mm / 1	18 mm / 1	18 mm / 1

Control and power supply interface



Voltage measurement module



Current measurement modules

Application	Control and power supply interface		
	Centralisation and display of data		Data centralisation
<i>DIRIS Digiware</i>	<i>D-40</i> <i>p. 20</i>	<i>D-50</i> <i>p. 20</i>	<i>C-31</i> <i>p. 20</i>
Function			
Centralisation of measurement points	•	•	•
High-resolution LCD display (configuration, selection and visualisation display of circuits)	•	•	
Power supply			
24 VDC	•	•	•
Communication			
RS485 Modbus	• Output	• Input	•
Digiware BUS	•	•	•
Ethernet Modbus TCP		•	

Application	Current measurement modules							
	Metering		Monitoring	Analysis	Monitoring	Analysis	Metering	
<i>DIRIS Digiware I</i>	<i>I-30</i> <i>p. 20</i>	<i>I-31</i> <i>p. 20</i>	<i>I-33</i> <i>p. 20</i>	<i>I-35</i> <i>p. 20</i>	<i>I-43</i> <i>p. 20</i>	<i>I-45</i> <i>p. 20</i>	<i>I-60</i> <i>p. 20</i>	<i>I-61</i> <i>p. 20</i>
Number of current inputs								
	3	3	3	3	4	4	6	6
Metering								
+/- kWh, +/- kvarh, kVAh	•	•	•	•	•	•	•	•
Load curves		•		•		•		•
Multi-tariff		•		•		•		•
Multi-measurement								
I1, I2, I3, In, ΣP, ΣQ, ΣS, ΣPF	•	•	•	•	•	•	•	•
P, Q, S, PF per phase			•	•	•	•		
Predictive power				•		•		
Current unbalance (Inba, Idir, Iinv, Ithom, Inb)				•		•		
Phi, cos Phi, tan Phi				•		•		
Quality								
THDi1, THDi2, THDi3, THDin			•	•	•	•		
Individual harmonics I (up to level 63)				•		•		
Overcurrents				•		•		
Alarms								
On threshold				•		•		
Inputs/Outputs					2/2	2/2		
History of average values								
45 days (max.)				•		•		
Format								
Width/Number of modules	18 mm / 1	18 mm / 1	18 mm / 1	18 mm / 1	27 mm / 1.5	27 mm / 1.5	36 mm / 2	36 mm / 2



DIRIS Digiware

Measurement and monitoring system for electrical installations

Multi-circuit metering & measurement

new



DIRIS Digiware D-50



DIRIS Digiware U-30



DIRIS Digiware I-35

The solution for

- > Industry
- > Building
- > Infrastructure
- > Local authority



Strong points

- > Multi-circuit
- > Global accuracy class 0.5 in accordance with IEC 61557-12
- > Cost effective and flexible
- > Plug & Play

Conformity to standards

- > IEC 61557-12



- > ISO 14025



- > UL



Configuration with EasyConfig, see page 142.

Function

The **DIRIS Digiware** system is a hub of technological innovations that revolutionises the world of measurements, bringing a high degree of flexibility to installations and making connection and configuration easy.

These innovations, together with unrivaled performance in terms of accuracy and functionality, make DIRIS Digiware the most effective solution for metering consumption, measuring and monitoring the quality of electrical energy in industrial and commercial applications.

- Management and optimisation of the power installed DIRIS Digiware allows you to identify most demanding loads and monitor abnormal electrical values, providing you with a perfectly-managed electrical network.
- Simplified network maintenance: the electrical energy quality monitoring functions offered by DIRIS Digiware make it easier to anticipate electrical malfunctions.

Advantages

Multi-circuit

Ability to monitor several circuits via a single current measurement module due to independent current inputs.

Accuracy as per standard IEC 61557-12

- Class 0.5 from 2% to 120% of nominal current for the global measurement chain (associated with TE/TF current sensors).
- Class 0.2 for the meter alone.

Cost effective and flexible

- Implementation in a quarter of the time vs existing technologies.
- Installation of modules and sensors at the closest point to the load.
- Shared functions:
 - Common display.
 - Single voltage measurement for the entire system.
 - Single auxiliary power supply.
- Compact design: suitable for new and existing installations including panels with space restrictions.
- Large range of current sensors

Plug & Play

- RJ12 current sensor connection
 - Automatic detection of ratings.
 - Identification of cables by color-coding.
 - Disconnection of the current sensor secondary under load.
- RJ45 interconnection of I and U modules via Digiware bus.
- Auto-configuration of parameters: Network and load type - addressing of devices connected to the bus.

Example of displays on DIRIS Digiware D-50

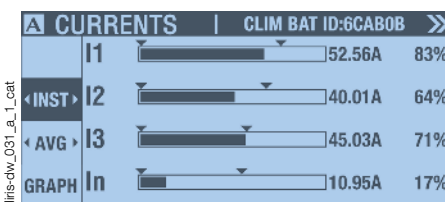
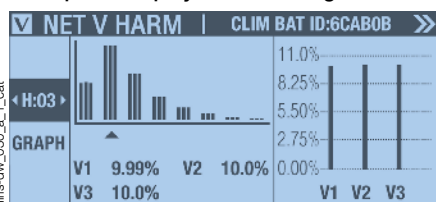

DIRIS Digiware System

- 1 display
- 1 voltage measurement module
- current measurement modules
- current sensors modules



diris-diw_011_la_cat

Control and power supply interface (24 VDC)



- High-resolution LCD display
- Centralisation of measurement points:
 - circuit selection,
 - data display.
- Keys on the front face for direct access to:
 - measurement data,
 - circuits selection,
 - device configuration.
- 24 VDC power supply.
- No-display mode
- Centralisation of DIRIS Digiware measurement data on RS485 Modbus
- 24 VDC power supply
- Communication
 - Digiware Bus,
 - RS485 Modbus.

	D50	D40
Input	RS485 Digiware	Digiware
Output	Ethernet	RS485

Voltage measurement module



DIRIS Digiware U-xx

- U-10**
 - U12, U23, U31, V1, V2, V3, f
- U-20**
 - U12, U23, U31, V1, V2, V3, f
 - THDv1, THDv2, THDv3,
 - THDu12, THDu23, THDu31
- U-30**
 - U12, U23, U31, V1, V2, V3, f
 - U system, V system
 - Ph/N unbalance (Vnb, Vnba, Vdir, Vinv, Vhom)
 - Ph/Ph unbalance (Unb, Unba, Udir, Uinv)
 - THDv1, THDv2, THDv3, THDu12, THDu23, THDu31
 - Individual harmonics U & V (up to rank 63)
 - Voltage dips, interruptions and swells (EN 50160)
 - Alarms
 - History of average values

Current measurement modules



DIRIS Digiware I-3x
3 inputs

DIRIS Digiware I-4x
4 inputs

DIRIS Digiware I-6x
6 inputs

- I-30 / I-60**
 - ± kWh, ± kvarh, kVAh
 - I1, I2, I3, In, ΣP, ΣQ, ΣS, ΣPF
- I-31 / I-61**
 - ± kWh, ± kvarh, kvah
 - Multi-tariff
 - Load curves
 - I1, I2, I3, In, ΣP, ΣQ, ΣS, ΣPF
 - P, Q, S, PF per phase
 - Predictive power (ΣP, ΣQ, ΣS)
- I-33 / I-43**
 - ± kWh, ± kvarh, kvah
 - I1, I2, I3, In, ΣP, ΣQ, ΣS, ΣPF
 - P, Q, S, PF per phase
 - THD11, THD12, THD13, THDIn
 - Individual harmonics I (up to rank 63)
 - Overcurrents
 - Alarms
 - 2 inputs / 2 outputs (I-45)
 - History of average values
- I-35 / I-45**
 - ± kWh, ± kvarh, kVAh
 - Multi-tariff
 - Load curves
 - I1, I2, I3, In, ΣP, ΣQ, ΣS, ΣPF
 - P, Q, S, PF per phase
 - Predictive power (ΣP, ΣQ, ΣS)
 - I System
 - Current unbalance (Inba, Idir, linv, lhom, lnb)
 - Phi, cos Phi, tan Phi
 - THD11, THD12, THD13, THDIn
 - Individual harmonics I (up to rank 63)
 - Overcurrents
 - Alarms
 - 2 inputs / 2 outputs (I-45)
 - History of average values

Terminals

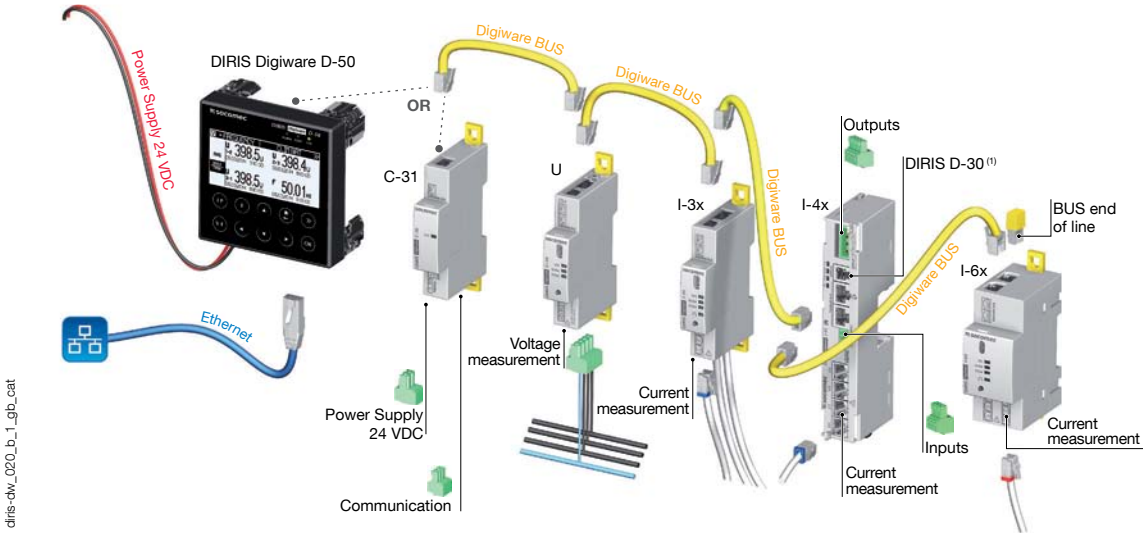

diris-dw_020_b_1_gb_cat

(1) a local single-point DIRIS D-30 display can be connected to the I-45 module



diris-dw_051_a_1_cat

DIRIS Digiware D-40

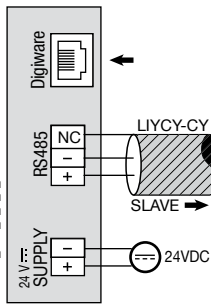

diris-dw_054_a_1_x_cat

DIRIS Digiware D-50

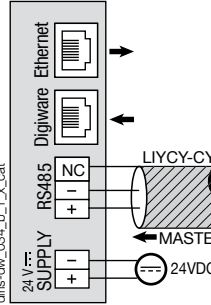

diris-dw_034_b_1_x_cat

DIRIS Digiware C-31

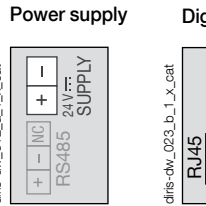

diris-dw_012_a_1_x_cat

diris-dw_023_b_1_x_cat

Communication

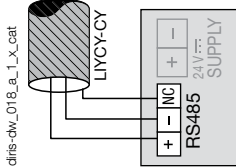

diris-dw_018_a_1_x_cat

DIRIS Digiware C-32

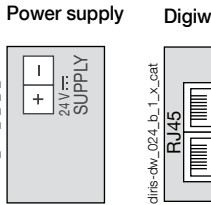

diris-dw_013_a_1_x_cat

diris-dw_024_b_1_x_cat

DIRIS Digiware U

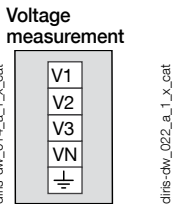

diris-dw_014_a_1_x_cat

diris-dw_022_a_1_x_cat

DIRIS Digiware I-3x

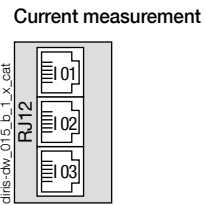

diris-dw_015_b_1_x_cat

diris-g_022_b_1_x_cat

DIRIS Digiware I-4x

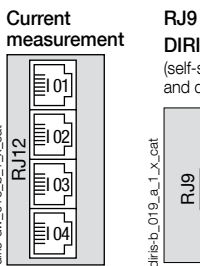

diris-dw_016_b_1_x_cat

diris-b_019_a_1_x_cat

Inputs

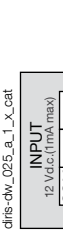

diris-dw_025_a_1_x_cat

Outputs

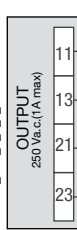

diris-dw_026_a_1_x_cat

Digiware BUS

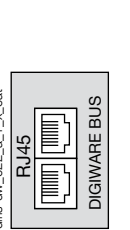

diris-dw_022_a_1_x_cat

DIRIS Digiware I-6x

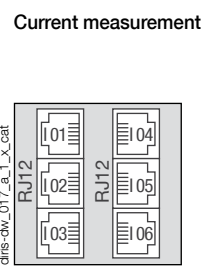

diris-dw_017_a_1_x_cat

diris-dw_022_a_1_x_cat

Connections

Associated current sensors

Various types of current sensors can be connected to the DIRIS Digiware: Solid TE, split-core TR, flexible TF current sensors. This range of sensors can be adapted to all types of new or existing installations. A rapid RJ12 connection makes wiring easy and reliable and prevents wiring errors. The DIRIS Digiware automatically recognises the sensor size and type. This guarantees the overall accuracy of the DIRIS Digiware + current sensor measurement chain.

For more information: see page 32.

TE solid current sensors



TR Split-core current sensors



TF Flexible current sensors

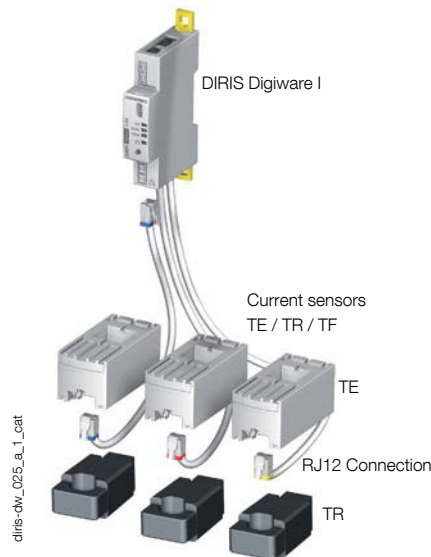

Network and connection examples

I3x

Three-phase

3P - 3CTs (1 three-phase load)

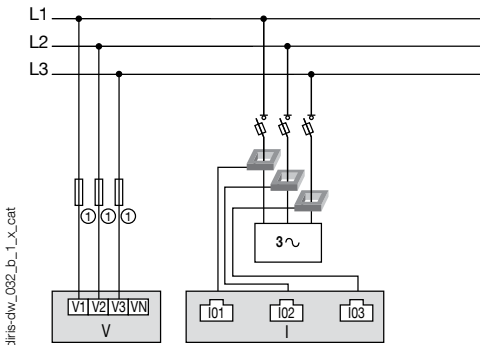

diris-dw_002_b_1_x_cat

Three-phase

3P - 1CT (3 three-phase balanced loads)

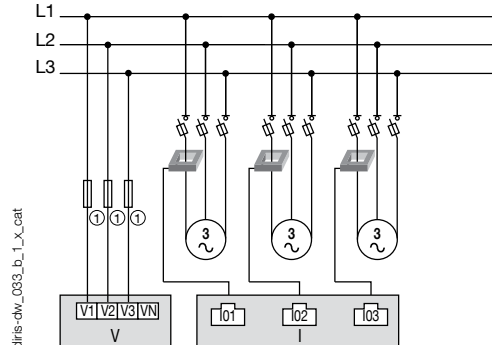

diris-dw_003_b_1_x_cat

I4x

Three phase + neutral

3P+N - 4CTs (1 three-phase load + Neutral)

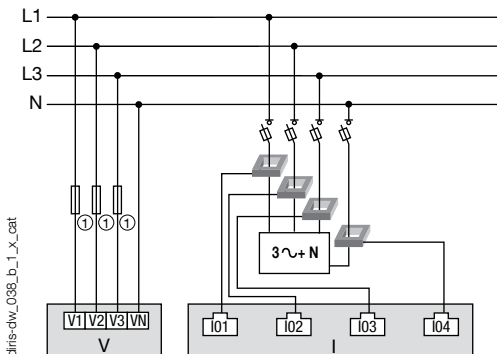

diris-dw_038_b_1_x_cat

Single-phase

1P+N-1CT (4 single-phase loads)

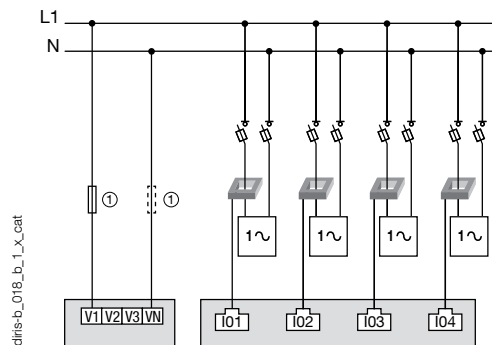

diris-b_018_b_1_x_cat

1. Fuses 0.5 A gG / 0.5 A class CC.

CT: Current sensors 3~ Load

Dimensions

DIRIS Digiware D-50

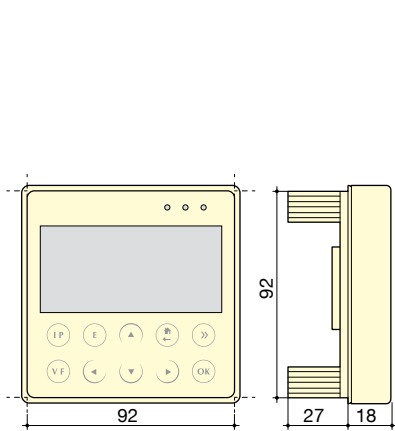

DIRIS Digiware U / C / I-3x / I-6x

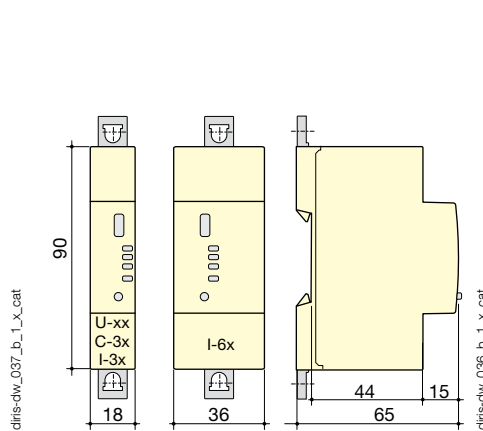

DIRIS Digiware I-4x

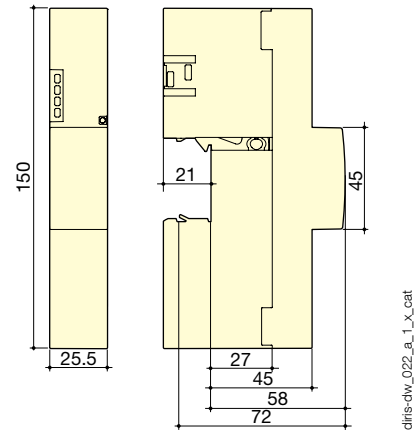

Configuration

Power consumption of devices

Components	Power supplied (W)	Power consumption (W)
Power supply		
P15 100-240 VAC / 24 VDC	15	
Cables		
50 metre package		1.5
System interfaces		
DIRIS Digiware D-x0		2
DIRIS Digiware C-31		0.8
Voltage module		
DIRIS Digiware U-xx		0.72
Current modules		
DIRIS Digiware I-3x		0.52
DIRIS Digiware I-4x		1.125
DIRIS Digiware I-6x		0.7
Repeater		
DIRIS Digiware C-32		1.5

Rules to set the maximum number of products on the Digiware BUS

The total power consumptions by the devices connected to the Digiware BUS must not exceed the power supplied by the 24 VDC supply. The power supply must not exceed 20 W / 70 °C or 27 W / 40 °C.

System configuration with P15 power supply (ref: 4829 0120) providing 15 W
System can include:

- 1 display DIRIS Digiware D-50 (2 W)
 - 1 voltage module DIRIS Digiware U-xx (0.72 W)
 - 50 meter cable (1.5 W)
- and
- 20 current modules DIRIS Digiware I-3x (20 x 0.52 = 10.4 W)
⇒ **Total power = 14.62 W**

- or
- 9 current modules DIRIS Digiware I-4x (9 x 1.125 = 10.125 W)
⇒ **Total power = 14.345 W.**

System configuration with a 24 VDC power supply providing a maximum of 20 W
System can include:

- 1 display DIRIS Digiware D-50 (2 W)
 - 1 voltage module DIRIS Digiware U-xx (0.72 W)
 - 50 meter cable (1.5 W)
- and
- 30 current modules DIRIS Digiware I-3x (30 x 0.52 = 15.6 W)
⇒ **Total power = 19.82 W**
- or
- 14 current modules DIRIS Digiware I-4x (14 x 1.125 = 15.72 W)
⇒ **Total power = 19.97 W.**

Repeater

When the power consumption is over 20 W or the distance exceeds 100 m, a DIRIS Digiware C-32 repeater is required. In a DIRIS Digiware system, maximum 2 repeaters can be used.

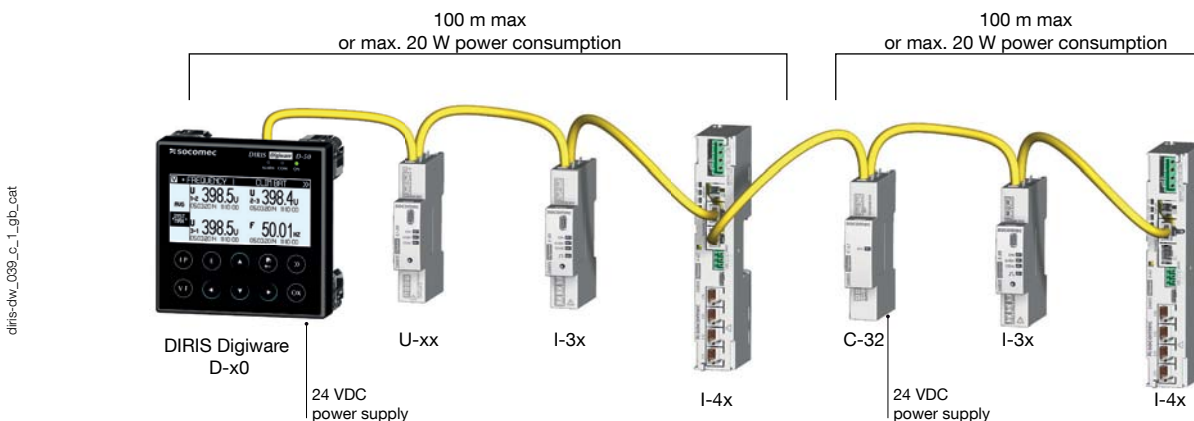

Technical characteristics

Electrical characteristics

DIRIS Digiware C-31	
Input voltage	24 VDC \pm 20 % - 20 W max
Connection	Removable screw terminal, 2 positions, 0.2 to 2.5 mm ² stranded or solid cable
P15 power supply	Characteristics: 100-240 VAC/ 24 VDC - 0.63 A - 15 W Modular format - Dimensions (H x L): 90 x 25 mm

Measurement characteristics

Energy and power measurement	
Accuracy	Class 0.2 DIRIS Digiware alone
Active energy and active power	Class 0.5 with TE or TF current sensors Class 1 with TR current sensors
Reactive energy accuracy	Class 2 with TE, TR or TF current sensors
Power factor measurement	
Accuracy	Class 0.5 with TE or TF current sensors Class 1 with TR current sensors

Voltage measurement - DIRIS Digiware U	
Network characteristics measured	50-300VAC (Ph/N) - 87-520VAC (Ph/Ph) - CAT III
Frequency range	45 ... 65Hz
Frequency accuracy	Class 0.02
Network type	Single-phase / Two-phase / Two-phase with neutral / Three-phase / Three-phase with neutral
Measurement by voltage transformer	Primary: 400 000 VAC Secondary: 60, 100, 110, 173, 190 VAC
Input consumption	\leq 0.1 VA
Permanent overload	300 VAC Ph/N
Voltage measurement accuracy	Class 0.2
Connection	Removable screw terminal, 4 positions, 0.2 to 2.5 mm ² stranded or solid cable

Current measurement - DIRIS Digiware I	
Number of current inputs	I-3x: 3 / I-45: 4 / I-6x: 6
Associated current sensors	Solid TE , split-core TR , flexible TF current sensors
Current measurement accuracy	Class 0.2 DIRIS Digiware alone Class 0.5 with TE or TF current sensors Class 1 with TR current sensors
Connection	Specific SOCOMEC cable with RJ12 connectors

Inputs - DIRIS Digiware I-45	
Number of inputs	2
Type / Power supply	Non insulated input, internal polarisation 12 VDC max, 1mA
Input functions	Logic status or pulse meter
Connection	Removable screw terminal, 0.14 to 1.5 mm ² stranded or solid cable

Outputs - DIRIS Digiware I-45	
Number of outputs	2
Relay type	230 VAC \pm 15 % - 1 A
Function	Configurable alarm (current, power,...) on threshold overruns or remote controlled status
Connection	Removable screw terminal, 0.2 to 2.5 mm ² stranded or solid cable

Communication characteristics

Digiware BUS	
Function	Connection between DIRIS Digiware modules
Type of cable	Specific SOCOMEC cable with RJ45 connectors
RS485	
Connection type	2 ... 3 half duplex wires
Protocol	Modbus RTU
Speed	1200 ... 115200 bauds
Function	Configuration and data transmission
Location	Single-point on DIRIS Digiware C
USB	
Protocol	Modbus RTU over USB
Function	Configuration of DIRIS Digiware U and I modules
Location	On each DIRIS Digiware U and I measuring module
Connection	B-type micro USB connector

Mechanical characteristics

Types of casing	Modular for DIN-rail or back plate mounting
Casing degree of protection	IP20 / IK06
Front face degree of protection	IP40 (panel face with modular mounting) / IK06

Environment characteristics

Operating temperature	-10 ... +70 °C
Storage temperature	-25 ... +70 °C
Operating humidity	55 °C / 97% relative humidity
Operating altitude	2000 m

DIRIS Digiware D-40 / D-50 characteristics

Mechanical characteristics	
Screen type	Capacitive touch-screen technology, 10 keys
Screen resolution	350 x 160 pixels
Front face degree of protection	IP65

Communication	
Ethernet RJ45 10/100 Mbs	Modbus TCP gateway function (D-50)
RJ45 Digiware	Control and power supply interface function
RS485 2-3 wires	Modbus RTU communication function (input D-50 / output D-40)
USB	Updating via B-type micro USB connector

Electrical characteristics	
Power supply	24 VDC +10% / -20%
Consumption	2 VA

Environment characteristics	
Storage temperature	-20 ... +70 °C
Operating temperature	-10 ... +55 °C
Humidity	95 % at 40 °C
Installation category - degree of pollution	CAT III, 2

References

DIRIS Digiware	Reference
D-40	Multi-point display - RS485 output
D-50	Multi-point display - Ethernet output
C-31	System interface
C-32	Repeater
U-10	Metering
U-20	Monitoring
U-30	Analysis
I-30	Metering - 3 current inputs
I-31	Metering + load curve - 3 current inputs
I-33	Monitoring - 3 current inputs
I-35	Analysis - 3 current inputs
I-43	Monitoring 2 inputs / 2 outputs - 4 current inputs
I-45	Analysis 2 inputs / 2 outputs - 4 current inputs
I-60	Metering - 6 current inputs
I-61	Metering + load curve - 6 current inputs

Power supply	Reference
P15	100-240 VAC/ 24 VDC 15 W power supply
Digiware connection cables	
Reference	
RJ45 cables for BUS Digiware	0.10 m length
	0.20 m length
	0.50 m length
	1 m length
	2 m length
	5 m length
	10 m length
50 m + 50 connectors	
Termination for Digiware BUS (fitted on C-31 and D-50)	
USB configuration cable	
Single-point display	
Reference	
DIRIS D-30 ⁽¹⁾	Single-point display for DIRIS Digiware I-4x

(1) DIRIS D-30 display characteristics



DIRIS B-30

Wireless power monitoring devices

Measurement and wireless metering

new



Configuration with EasyConfig, see page 142.

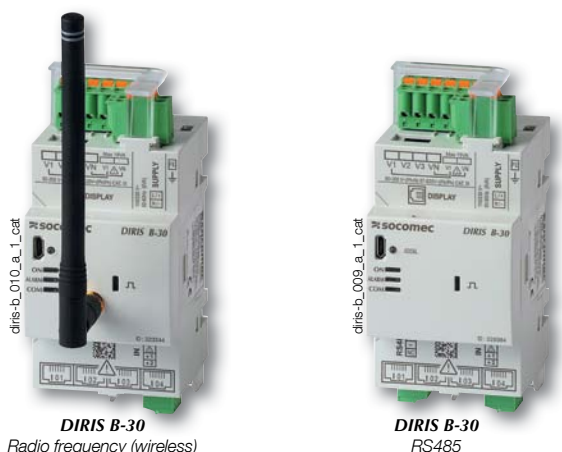

DIRIS B-30
Radio frequency (wireless)

DIRIS B-30
RS485

The solution for

- > Industry
- > Building
- > Infrastructure
- > Local authority



Strong points

- > Plug & Play
- > Global accuracy class 0.5 in accordance with IEC 61557-12
- > Multi-circuit
- > Communication

Conformity to standards

- > IEC 61557-12
- > EN 50160
- > ISO 14025



Function

The DIRIS B-30 is a power monitoring device in a modular format that communicates wirelessly or via RS485. The 4 RJ12 independent current inputs of the device allow it to manage several types and number of circuits: for example, 4 single-phase loads or 1 three-phase load + 1 single-phase load.

The DIRIS B-30 is connected to current sensors⁽¹⁾ (RJ12 connection) that are suitable for all types of installation: solid TE, split-core TR, and flexible TF current sensors.

⁽¹⁾ See page 32.

Advantages

Plug & Play

A rapid RJ12 connection makes wiring easy and reliable and prevents wiring errors. Automatically addressing and configuring the product (communication address, load type, type and ratio of current sensor) allow you to simplify implementation and to save time.

Class 0.5 in accordance with IEC 61557-12

- Class 0.2 for the meter alone.
- Class 0.5 from 2% to 120% of nominal current for the global measurement chain (associated with TE/TF current sensors).

Multi-circuit

- 4 current measurement inputs allow you to configure multiple circuits in order to optimise the number of measurement devices per installation.

Communication

- The DIRIS B-30 can be connected to:
 - a remote DIRIS D-30 screen for displaying measurement and metering data.
 - a DIRIS G⁽¹⁾ gateway for centralisation and communication of data wirelessly or via RS485 and Ethernet.
 - optional modules to communicate in BACnet IP, BACnet MSTP and PROFIBUS DP protocol. Digital or analogue input/output modules can also be connected.

⁽¹⁾ See page 124.

Functions

Multi-measurement

- Currents
 - I1, I2, I3, In, Isystem
- Voltages & frequency
 - V1, V2, V3, VN, Vsystem, U12, U23, U31, Usystem, f
- Power
 - P1, P2, P3, ΣP, Q1, Q2, Q3, ΣQ, S1, S2, S3, ΣS
 - Predictive power ΣP, ΣQ, ΣS
- Power factor
 - PF1, PF2, PF3, ΣPF
- Cos φ & tanφ
 - Instantaneous values per phase

Metering

- Active energy: +/- kWh
- Reactive energy: +/- kvarh
- Apparent energy: kVAh
- Multi-tariff (8 max.)

Quality

- Voltage Unbalance
 - Vdir, Vinv, Vhom, Udir, Uinv, Unba, Vnba, Vnb, Unb
- Current unbalance
 - Idir, linv, Ihom, Inba, Inb
- Total harmonic distortion
 - Currents THDi1, THDi2, THDi3, THDIN
 - Phase-to-neutral voltage THDv1, THDv2, THDv3
 - Phase-to-phase voltage THDu12, THDu23, THDu31
- Individual harmonics up to rank 63
 - Currents: I1h, I2h, I3h, INh
 - Phase-to-neutral voltage: V1h, V2h, V3h
 - Phase-to-phase voltage: U12h, U23h, U31h
- Active (according to EN 50160)
 - Dips, interruptions, swells

Load curves and history logs (130 days max.)

- Active, reactive and apparent power
- Currents, voltages and frequency

Alarms

- Alarms for all electrical values, events and input status changes, possibility of boolean combination

Communication

- DIRIS B-30 RF: Radio frequency Communication (wireless)
- DIRIS B-30 RS: RS485 Modbus,
- Optional modules: RS485, BACnet IP, BACnet MSTP, PROFIBUS DPV1

Inputs

- 2 digital inputs
 - Supply by the DIRIS B-30 or external supply
 - Function: logic status, circuit breaker status, pulse meter or synchronisation pulse

Selection guide

DIRIS B-30	
DIRIS B-30 RS	RS485 MODBUS communication
DIRIS B-30 RF	Radio frequency Communication (wireless)
Optional modules	
DIRIS O-iod	2 digital inputs / 2 digital outputs
DIRIS O-ioa	2 analogue inputs / 2 analogue outputs
DIRIS O-it	3 temperature inputs
DIRIS O-m	Additional RS485 communication
DIRIS O-p	PROFIBUS communication
DIRIS O-b/ip	BACnet IP communication
DIRIS O-b/mstp	BACnet MSTP communication

DIRIS B-30 display

DIRIS D-30



Dimensions

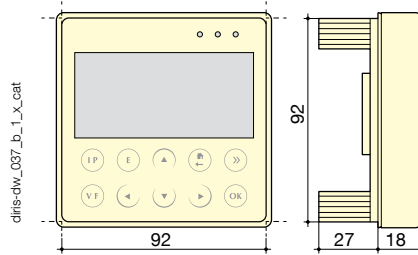

Connection



Optional modules

DIRIS O

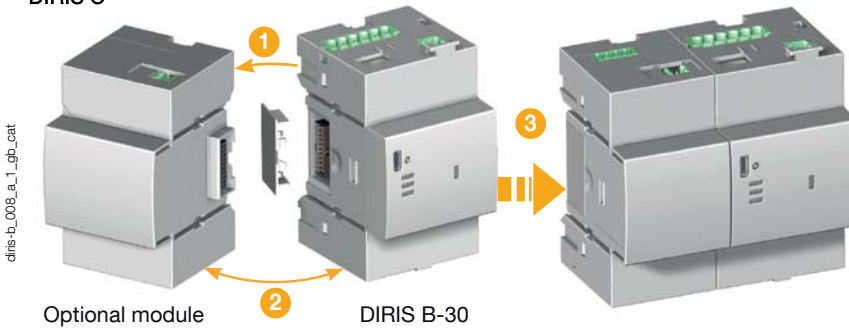

Optional modules (4 max.)*

- Digital inputs/outputs
- Analogue inputs/outputs
- Temperature inputs
- Communication protocols

* maximum 4 optional modules with maximum 1 temperature module and 1 communication module (Modbus, PROFIBUS, BACnet IP or BACnet MSTP).

DIRIS O-iod

- 2 digital inputs centralises the metering pulses or the input status changes of the auxiliary contacts.
- 2 digital outputs can be connected to configurable alarms warning of exceeded thresholds (power, current, etc.) or can be piloted remotely.

DIRIS O-m

- Provides a second RS485 Modbus communication port to the DIRIS B-30 for simultaneous sending of information via RS485 to two supervision stations.

DIRIS O-ioa

- 2 inputs (4-20 mA) centralise analogue sensors (pressure, humidity, temperature, etc.)
- 2 outputs (4/-20 mA) report the measurements (power, currents, etc.) to PLCs.

DIRIS O-p

- Adds a PROFIBUS DPV1 communication port to the DIRIS B-30.

DIRIS O-it

- 3 temperature inputs to be connected to PT100 or PT1000 sensors.
- Ambient air temperature:

DIRIS O-b/ip

- Adds a BACnet IP communication port to the DIRIS B-30.

DIRIS O-b/mstp

- Adds a BACnet MSTP communication port to the DIRIS B-30.

Accessories

Remote radio antenna

- Mounted outside the enclosure of the DIRIS B-30 monitoring device to increase the transmission distance.

DIRIS B-30 sealing cover

- Prevents access to the cabling of the monitoring device.

USB configuration cable (2 m)

- Advanced configuration of DIRIS B-30 gateways can be achieved using the EASY CONFIG software via Ethernet or direct USB connection.

DIRIS B-30

Wireless power monitoring devices

DIRIS B-30 terminals

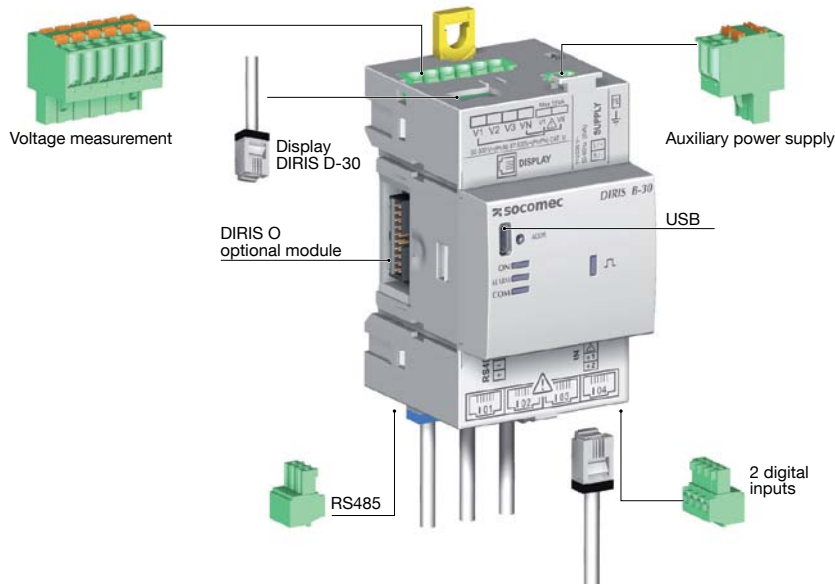

diris-d_027_b_1_glb_cat

Current measurement

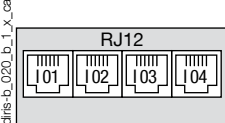

Voltage measurement and auxiliary power supply

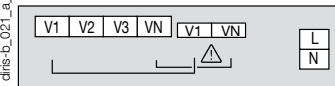

2 inputs supplied by the product

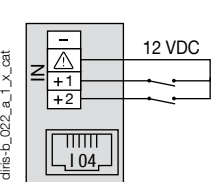

diris-o_022_a_1_x_cat

Self supply

Easy connection of the power supply from the measurement terminal (specific terminals)

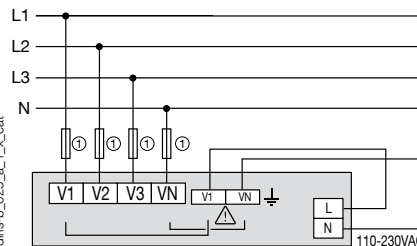

1. Fuses 0.5 A gG / 0.5 A class CC.

diris-b_025_a_1_x_cat

Separate power supply

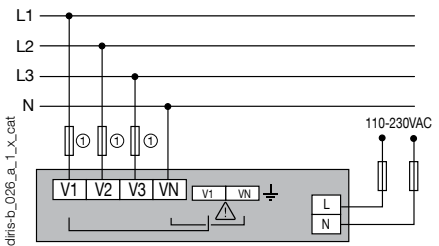

1. Fuses 0.5 A gG / 0.5 A class CC.

diris-b_026_a_1_x_cat

2 inputs with external power supply

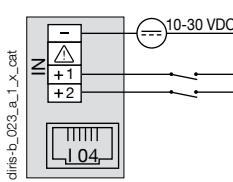

diris-b_023_a_1_x_cat

RS485

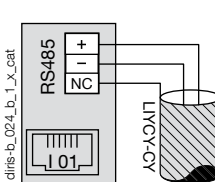

diris-b_024_b_1_x_cat

RJ9 for DIRIS D-30 (self-supply and data)

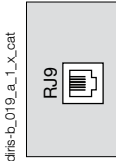

diris-b_019_a_1_x_cat

Terminals of optional DIRIS O modules

Optional module power supply

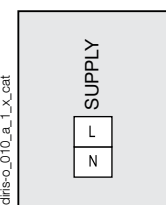

diris-o_010_a_1_x_cat

DIRIS O-iod

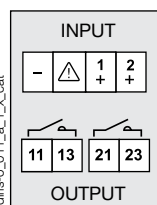

diris-o_011_a_1_x_cat

DIRIS O-ioa

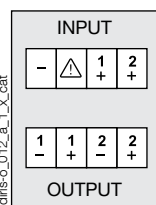

diris-o_012_a_1_x_cat

DIRIS O-it

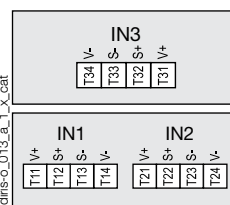

diris-o_013_a_1_x_cat

DIRIS O-m RS485

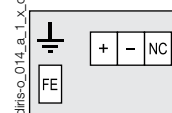

diris-o_014_a_1_x_cat

DIRIS O-p

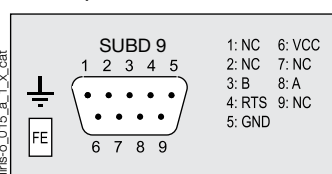

diris-o_015_a_1_x_cat

DIRIS O-b/ip

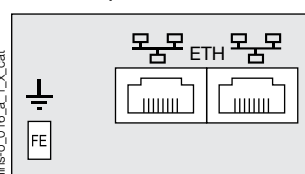

diris-o_016_a_1_x_cat

DIRIS O-b/mstp

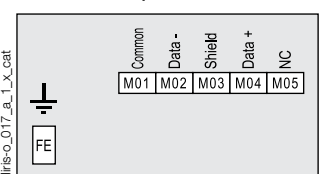

diris-o_017_a_1_x_cat

Connections

Associated current sensors

Various types of current sensors can be connected to the DIRIS Digiware: Solid TE, split-core TR, flexible TF current sensors. This range of sensors can be adapted to all types of new or existing installations. A rapid RJ12 connection makes wiring easy and reliable and prevents wiring errors. The DIRIS B-30 automatically recognises the sensor size and type. This guarantees the overall accuracy of the DIRIS B-30 + current sensor measurement chain.
For more information: see page 32.

TE solid current sensors

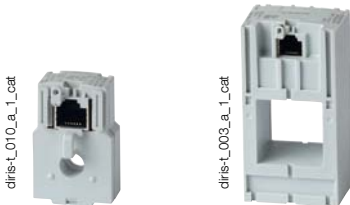

TR Split-core current sensors



TF Flexible current sensors

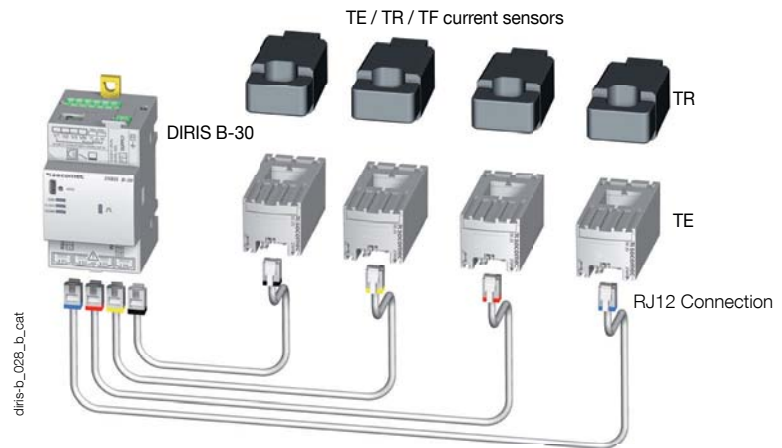

Network and connection examples

Three phase + neutral

3P+N - 4CTs (measurement for 1 three-phase load + Neutral)

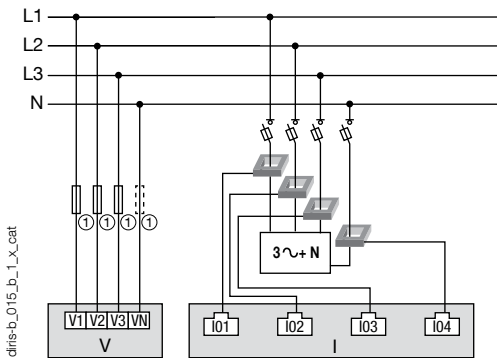

Three-phase

3P - 2CTs (2 three-phase loads without neutral)

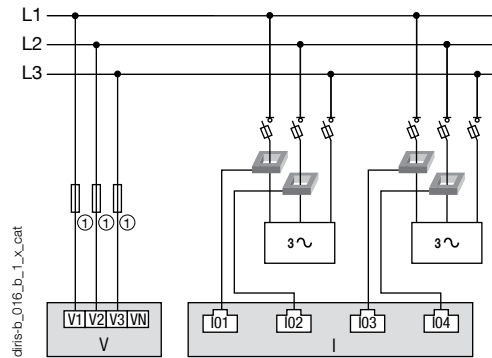

Three-phase

3P+N - 3CTs & 1P+N - 1CT (1 three-phase load & 1 single-phase load)

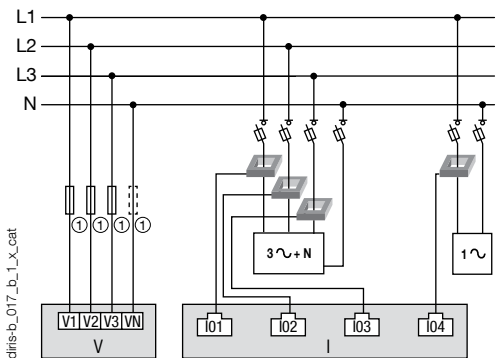

Single-phase

1P+N-1CT (4 single-phase loads)

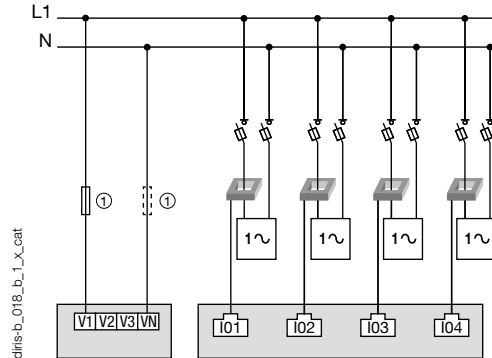

1. Fuses 0.5 A gG / 0.5 A class CC.

In case of self-supply, a fuse must be added on the neutral.



CT: Current sensors



Load

DIRIS B-30

Wireless power monitoring devices

Dimensions (mm)

DIRIS B-30

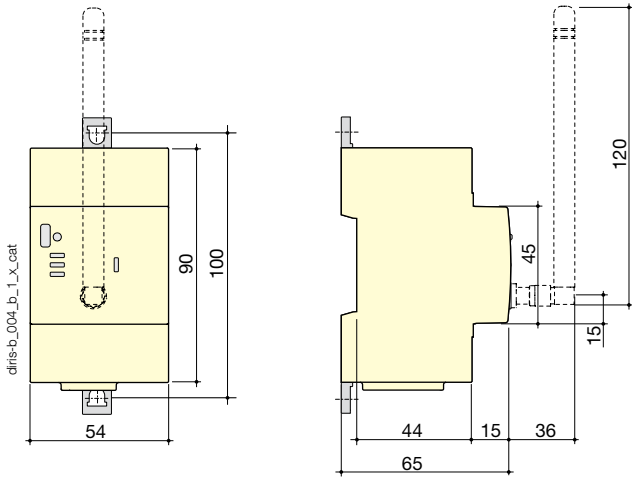

DIRIS O optional modules

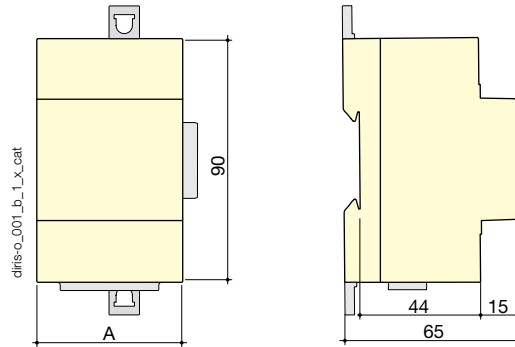

DIRIS O optional modules	A
DIRIS O-iod - DIRIS O-iaa - DIRIS O-it	45 mm
DIRIS O-m - DIRIS O-p - DIRIS O-b/ip - DIRIS O-b/mstp	54 mm

Communication architecture

Example of communication architecture with DIRIS G gateway and WEBVIEW embedded WEB server
For more information about DIRIS G, see page 124.

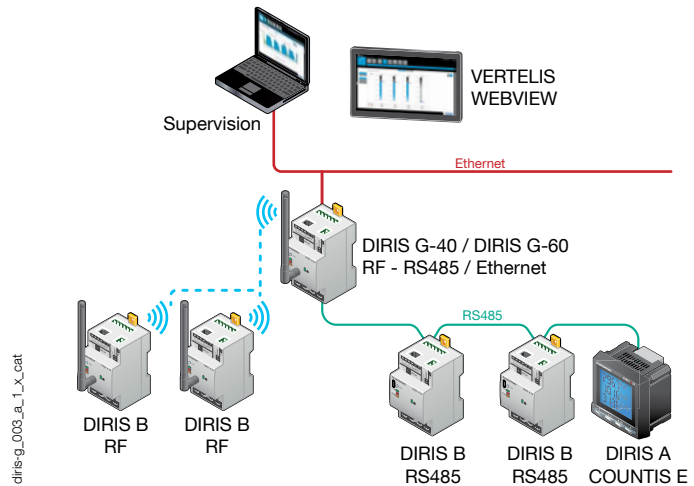

References

DIRIS B-30 monitoring devices		Reference
DIRIS B-30	RS485 - Modbus - 230VAC	4829 0000
DIRIS B-30	RF - Modbus - 230 VAC	4829 0002

DIRIS O optional modules		Reference
DIRIS O-iod	2 digital inputs / 2 digital outputs	4829 0030
DIRIS O-iaa	2 analogue inputs/2 analogue outputs 4-20 mA	4829 0031
DIRIS O-it	3 temperature inputs PT 100 / PT 1000	4829 0032
DIRIS O-m	RS485 Modbus communication	4829 0033
DIRIS O-p	PROFIBUS communication	4829 0034
DIRIS O-b/ip	BACnet IP communication	4829 0035
DIRIS O-b/mstp	BACnet MSTP communication	4829 0036

Accessories		Reference
DIRIS D-30	Single-point display	4829 0200
RJ9 cable for DIRIS D-30 display	- 1.5 m	4829 0280
RJ9 cable for DIRIS D-30 display	- 3 m	4829 0281
Wireless remote antenna, 868 MHz	- 210 mm height	4854 0126
Cable for remote antenna	- SMA connector - 3 meter length	4854 0127
DIRIS B-30 sealing cover for I/O terminals		4829 0049
USB configuration cable		4829 0050

DIRIS B-30 characteristics

Electrical characteristics

Auxiliary power supply	
AC voltage	110-230VAC $\pm 15\%$ (Ph/N ou Ph/Ph) Cat III
Frequency	50/60 Hz
Consumption	< 2VA without display < 6VA with display
Connection	Removable spring-cage terminal, 2 x 2 positions, 0.5 ... 2.5 mm ² solid cable or 0.25 ... 1.5 mm ² stranded cable with ferrule

Measurement characteristics

Energy and power measurement	
Accuracy	Class 0.2 DIRIS B-30 alone
Active energy and active power	Class 0.5 with TE or TF current sensors Class 1 with TR current sensors
Reactive energy accuracy	Class 2 with TE, TR or TF current sensors
Power factor measurement	
Accuracy	Class 0.5 with TE or TF current sensors Class 1 with TR current sensors
Voltage measurement	
Network characteristics measured	50-300VAC (Ph/N) - 87-520VAC (Ph/Ph) - CAT III
Frequency range	45 ... 65Hz
Frequency accuracy	Class 0.02
Network type	Single-phase / Two-phase / Two-phase with neutral / Three-phase / Three-phase with neutral
Measurement by voltage transformer	Primary: 400 000 VAC Secondary: 60, 100, 110, 173, 190 VAC
Input consumption	≤ 0.1 VA
Permanent overload	300VAC Ph/N
Voltage measurement accuracy	Class 0.2
Connection	Removable spring-cage terminal, 2 x 6 positions, 0.5 ... 2.5 mm ² solid cable or 0.25 ... 1.5 mm ² stranded cable with ferrule

Current measurement

Number of current inputs	4
Associated current sensors	Solid TE , split-core TR , flexible TF current sensors
Accuracy	Class 0.2 DIRIS B-30 alone Class 0.5 with TE or TF current sensors Class 1 with TR current sensors
Connection	RJ12 connectors with specific SOCOMEC cable

Input characteristics

Number	2
Type / Power supply	Optocoupler internal polarisation (12 VDC $\pm 10\%$) or external polarisation (10-30 VDC $\pm 10\%$)
Input function	Logic status, pulse meter or synchronisation pulse status (input 1)

Communication characteristics

DIRIS B-30 RS485	
Link	RS485
Connection type	2 ... 3 half duplex wires
Protocol	Modbus RTU
Speed	1200 ... 115200 bauds
USB	DIRIS B-30 RS485 configuration
DIRIS B-30 RF	
Link	Wireless radio frequency
Frequency band	868 MHz (low frequency: 868.1 MHz and high frequency: 869.5875 MHz)
Speed	38400 bauds
USB	DIRIS B-30 RF configuration

Environment characteristics

Operating temperature	-10 ... +70 °C
Storage temperature	-25 ... +85 °C
Operating humidity	55 °C / 97% relative humidity
Operating altitude	2000 m
Vibration	1G from 10 Hz to 100Hz

DIRIS D-30 display characteristics

Mechanical characteristics	
Screen type	Capacitive touch-screen technology, 10 keys
Screen resolution	350 x 160 pixels
Single product connection	
RJ9	Self-supply and data
Micro-USB	Updating
Degree of protection	IP65 (front face)
Electrical characteristics	
Power supply	24 VDC $+10\%$ / -20%
Consumption	2 VA
Environment	
Storage temperature (°C)	-20/+55
Operating temperature (°C)	-20/+55
Humidity	95 % to 40°C
Installation category	CAT III
Degree of pollution	2

DIRIS O optional modules characteristics

Power supply ⁽¹⁾	
AC voltage	110-230 VAC $\pm 15\%$
Frequency	50/60 Hz

(1) No power supply on DIRIS O-it.

DIRIS O-iod - 2 digital inputs/2 digital outputs	
Number of inputs	2 per optional modules - max. 4 optional modules
Type	Optocoupler internal polarisation (12 VDC $\pm 10\%$) or external polarisation (10-30 VDC $\pm 10\%$)
Function	Logic status or pulse meter
Number of outputs	2 per optional modules - max. 4 optional modules
Type	Relay / 230VAC $\pm 15\%$ - 1 A
Function	Configurable alarm (current, power,...) on threshold overruns or remote controlled status
Inputs/Outputs connection	Removable screw terminal, 4 positions, 0.14 to 1.5 mm ² stranded or solid cable

DIRIS O-ioa - 2 analogue inputs/2 analogue outputs	
Number of inputs	2 per optional modules - max. 4 optional modules
Type	4-20 mA
Function	Connection of analogue sensors (pressure, humidity, temperature...)
Number of outputs	2 per optional modules - max. 4 optional modules
Type	4-20 mA
Function	Transmission of measurement image (current, power...) to PLCs

DIRIS O-it - 3 temperature inputs	
Number of inputs	3 external inputs + 1 measurement for ambient temperature
Dynamic	-20 °C to 150 °C
Type	PT100 or PT1000
Function inputs 1, 2 and 3	Temperature measurement

DIRIS O-m - RS485 communication	
Link	RS485 2 ... 3 half duplex wires
Protocol	Modbus RTU
Speed	1200 ... 115200 bauds
Connection	Removable screw terminal, 3 positions, 0.14 to 1.5 mm ² stranded or solid cable

DIRIS O-p - PROFIBUS communication	
Protocol	PROFIBUS DPV1

DIRIS O-b/ip - BACnet IP communication	
Protocol	BACnet IP
Speed	10 ... 100 Mbit/s

DIRIS O-b/mstp - BACnet MSTP communication	
Protocol	BACnet MSTP
Speed	9600 ... 76800 bauds



TE, TR and TF current sensors

Current sensors

associated to DIRIS Digiware and DIRIS B-30

Current sensors

new



TE Solid current sensors



TR Split-core current sensors TF Flexible current sensors

The solution for

- > Industry
- > Building
- > Infrastructure
- > Local authority



Strong points

- > Plug & Play
- > Accuracy as per standard IEC 61557-12
- > Suitable for any installation

Services & Technical Assistance

- > Technical site audits and solution specification, commissioning, maintenance, training... Our Services & Technical Assistance experts offer you personalised support to ensure success with all your projects.

Conformity to standards

- > IEC 61557-12



- > ISO 14025



- > UL



Function

TE, TR and TF current sensor ranges can be connected to DIRIS Digiware and DIRIS B-30 via a rapid RJ12 connection. Various accessories are available to allow the installation of sensors in all panel configurations.

Thanks to a wide measurement range, the TE current sensors cover the full current range from 5 to 1000 A, with only 6 models.

Advantages

Plug & Play

- A rapid RJ12 connection makes wiring easy and reliable and prevents wiring errors. This also allows automatic detection of the sensor type and size/transformation ratio.
- Mounting orientation of current sensors is indifferent.

Accuracy as per standard IEC 61557-12

- Class 0.5 from 2% to 120% of nominal current for the global measurement chain (associated with TE or TF current sensors).
- Class 1 from 2% to 120% of nominal current for the global measurement chain (associated with TR current sensors).

Suitable for any installation

Dimensions of the range allow:

- New installation: a range of solid TE sensors adapted to the pitch of protective devices.
- Existing installations: a range of split-core TR sensors for existing sites.
- Existing space-constrained installations with high-intensity currents: a range of flexible TF current sensors (Rogowski).

Selection guide

Current sensors	TE Solid current sensors	TR Split-core current sensors	TF Flexible current sensors
Nominal current range (A)	5 ... 1000	25 ... 600	150 ... 6000

Functions

TE range

- Solid current sensors.
- Plug & Play RJ12 connection.
- High accuracy over the whole operating range.
- 6 models with ratings from 5 to 1000 A that are adapted to the pitch of protective devices (18/25/35/45/55 mm).
- A 5A/RJ12 adapter for use with TC 5A current transformers in the DIRIS Digiware and DIRIS B-30 ranges.
- Accessories for back-plate, DIN-rail, cable or bar mounting.

TR range

- Split-core current sensors.
- Plug & Play RJ12 connection.
- High accuracy over the whole operating range.
- 4 models with ratings from 25 to 600 A.
- Apertures from 10 to 36 mm.

TF range

- Split-core current sensors.
- Plug & Play RJ12 connection.
- High accuracy over the whole operating range.
- 3 models with different ratings (from 150 to 6000 A).
- Apertures from 55 to 300 mm.

Mounting

TE range

Linear mounting (circuit breaker pitch)
TE-25 / TE-35 / TE-45 / TE-55

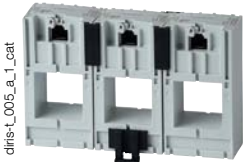

DIN-rail mounting



Staggered mounting

TE-18 / TE-35 / TE-45 / TE-55



Back-plate mounting

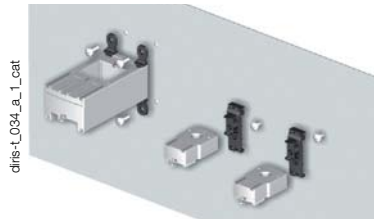

Cable mounting



Bar mounting

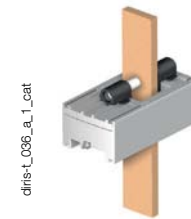

TR range

Cable mounting

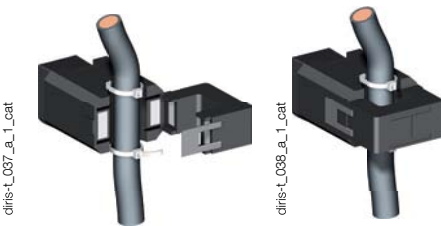

TF range

Cable mounting

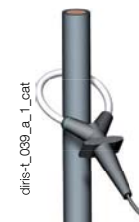

Bar mounting

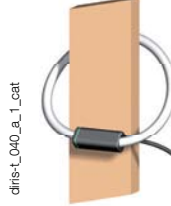

Connections

DIRIS B-30
or DIRIS DIGIWARE I

TE / TR / TF current sensors

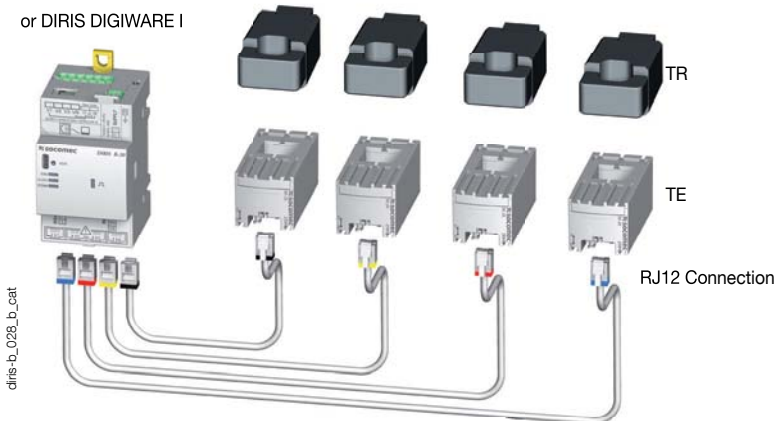

Mounting accessories

Mounting accessories provided
with TE current sensors

Fixing		TE-18	TE-25	TE-35 TE-45 TE-55
DIN-rail or back plate		1 part		
DIN-rail			2 parts	2 parts
Back plate			4 parts	4 parts
Bar				2 parts

diris-t_042_a - 043_a - 044_a - 045_a

Accessories

Adapter for 5A CT

• This adapter is for use with a 5 A CT with output terminals on the DIRIS Digiware and DIRIS B-30. For use with standard 5 A current sensors for > 1000 A measurement requirements. Dimensions are identical to TE-18. See page 35.



Coupling link

• Associated with the TE range, this accessory is for inter-connecting the sensors when linear or staggered mounted.



Sealable cover

• Using a sealable cover guarantees the immunity of the sensor connection on TE/TR/TF current sensors.

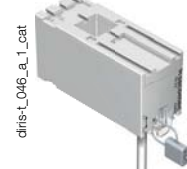

TE, TR and TF current sensors

current sensors

associated to DIRIS Digiware and DIRIS B-30

Dimensions (mm)

TE - Solid current sensors

TE-18

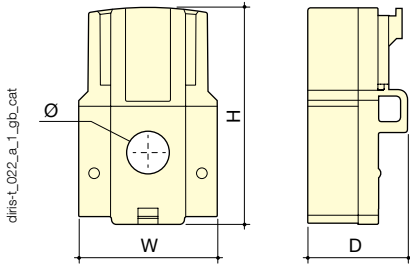

Model	Nominal current range (A)	Pitch (mm)	H x W x D (mm)	Ø (mm)
TE-18	5 ... 63	18	45 x 28 x 20	8,6

TE-25 / TE-35 / TE-45 / TE-55

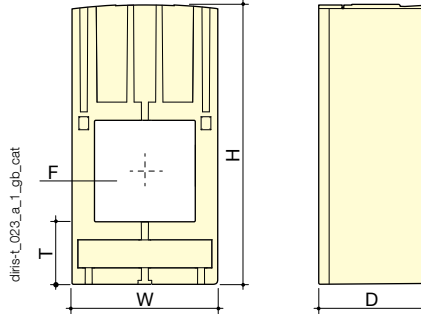

Model	Nominal current range (A)	Pitch (mm)	H x W x D (mm)	F (mm)	T
TE-25	40 ... 160	25	65 x 25 x 32.5	13.5 x 13.5	17,5
TE-35	63 ... 250	35	71 x 35 x 32.5	21 x 21	17,5
TE-45	160 ... 630	45	86 x 45 x 32.5	31 x 31	19,5
TE-55	400 ... 1000	55	100 x 55 x 32.5	41 x 41	21,5

TR - Split-core current sensors

TR-10 / TR-16 / TR-24 / TR-36

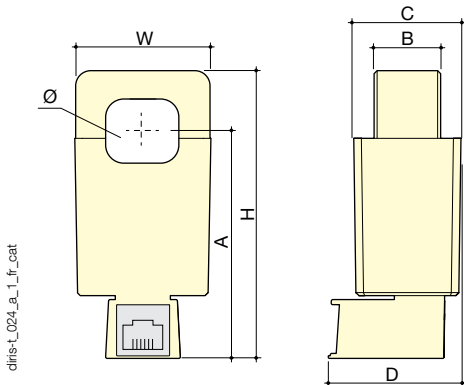

Model	Nominal current range (A)	H x W x D (mm)	Ø (mm)	A	W	C
TR-10	25 ... 75	71 x 25 x 39	10	58	14,5	26
TR-16	32 ... 100	74 x 30 x 42	16	61	19	31
TR-24	63 ... 200	95 x 45 x 44	24	72	22	34
TR-36	200 ... 600	111 x 57 x 42	36	82	34	40,5

TF - Flexible current sensors

TF-55

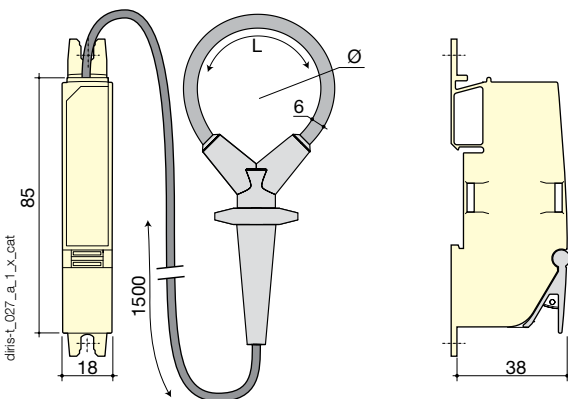

Model	Nominal current range (A)	Ø loop	L = loop length
TF-55	150 ... 600	55	172

TF-120 / TF-300

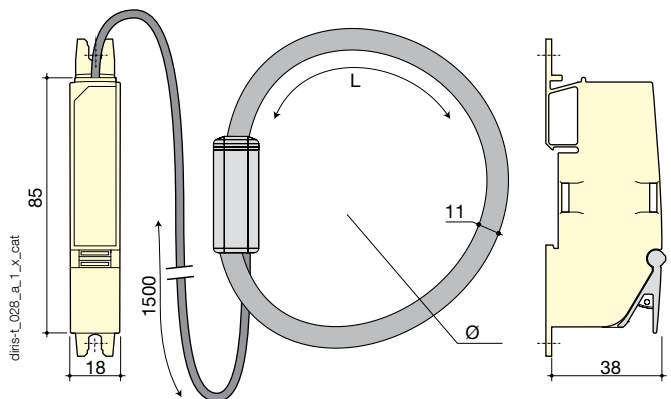

Model	Nominal current range (A)	Ø loop	L = loop length
TF-120	500 ... 2000	120	376
TF-300	1600 ... 6000	300	942

Technical characteristics

TE - Solid current sensors

Model	TE-18	TE-18	TE-25	TE-35	TE-45	TE-55
Nominal current range (A)	5 ... 20	25 ... 63	40 ... 160	63 ... 250	160 ... 630	400 ... 1000 ⁽¹⁾
Max. current (A)	24	75.6	192	300	756	1200
Weight (g)	24	24	69	89	140	187
Max. voltage	300 V			600 V		
Rated withstand voltage	3 kV			3,6 kV		
Frequency	50/60 Hz					
Intermittent overload	10 x I _n during 1sec					
Measurement category	CAT III					
Degree of protection	IP30 / IK06					
Operating temperature	-10 ... +70 °C					
Storage temperature	-25 ... +85 °C					
Relative humidity	95 % non-condensing					
Altitude	2000 m					
Connection	SOCOMECC cable or equivalent RJ12 straight, twisted pair, unshielded 300 V cat. III cable. -40 / +85 °C					

(1) > 1000 A with 5A CT adapter.

TR - Split-core current sensors

Model	TR-10	TR-16	TR-24	TR-36
Nominal current range (A)	25 ... 75	32 ... 100	63 ... 200	200 ... 600
Max. current (A)	90	120	240	720
Weight (g)	74	117	211	311
Max. voltage	300 V			
Rated withstand voltage	3 kV			
Frequency	50/60 Hz			
Intermittent overload	10 I _n for 1 s			
Measurement category	CAT III			
Degree of protection	IP20 / IK06			
Operating temperature	-10 ... +70 °C			
Storage temperature	-25 ... +85 °C			
Relative humidity	95 % non-condensing			
Altitude	2000 m			
Connection	SOCOMECC cable or equivalent RJ12 straight, twisted pair, unshielded 300 V cat. III cable. -40 / +85 °C			

TF - Flexible current sensors

Model	TF -55	TF -120	TF -300
Nominal current range (A)	150 ... 600	500 ... 2000	1600 ... 6000
Weight (g)	114	142	220
Max. voltage	600 V		
Rated withstand voltage	3,6 kV		
Frequency	50 / 60 Hz		
Intermittent overload	10 I _n for 1 s		
Measurement category	CAT III		
Degree of protection	IP30 / IK07		
Operating temperature	-10 ... +70 °C		
Storage temperature	-25 ... +75 °C		
Relative humidity	95 % non-condensing		
Altitude	2000 m		
Connection	SOCOMECC cable or equivalent RJ12 straight, twisted pair, unshielded 300 V cat. III cable. -40 / +85 °C		

References

TE - Solid current sensors

Model	Nominal current range (A)	Pitch (mm)	Reference
TE-18	5 ... 20	18	4829 0500
TE-18	25 ... 63	18	4829 0501
TE-25	40 ... 160	25	4829 0502
TE-35	63 ... 250	35	4829 0503
TE-45	160 ... 630	45	4829 0504
TE-55	400 ... 1000	55	4829 0505

TF - Flexible current sensors

Model	Nominal current range (A)	Ø (mm)	Reference
TF -55	150 ... 600	55	4829 0570
TF -120	500 ... 2000	120	4829 0571
TF -300	1600 ... 6000	300	4829 0572

Accessories	Reference
Coupling links (20 parts for linear mounting and 10 parts for staggered mounting)	4829 0598
5A/CT adapter (measurement >1000 A)	4829 0599
Sealable covers (20 parts)	4829 0600

TR - Split-core current sensors

Model	Nominal current range (A)	Ø (mm)	Reference
TR-10	25 ... 75	10	4829 0551
TR-16	32 ... 100	16	4829 0552
TR-24	63 ... 200	24	4829 0553
TR-36	200 ... 600	36	4829 0554

RJ12 connection cables	Cable length (m)								
	0,1	0,2	0,3	0,5	1	2	5	10	50 m + 50 connectors
N° of cables	Reference	Reference	Reference	Reference	Reference	Reference	Reference	Reference	Reference
1	-	-	-	-	-	-	4829 0602	4829 0603	4829 0601
3	4829 0580	4829 0581	4829 0582	4829 0595	4829 0583	4829 0584	-	-	-
4	4829 0585	4829 0586	4829 0587	4829 0596	4829 0588	4829 0589	-	-	-
6	4829 0590	4829 0591	4829 0592	4829 0597	4829 0593	4829 0594	-	-	-



Selection guide

Active energy meters and pulse concentrators COUNTIS E

Single-circuit metering,
measurement &
analysis

Which type
of network?

Which load
current?

Network - Input current	Single-phase Direct up to 32 A		Single-phase Direct up to 63 A	Single-phase Direct up to 80 A		Three-phase Direct up to 63 A	
		new 		new 			new
Active energy meters: COUNTIS E	<i>E00/E02</i> <i>p. 38</i>	<i>E03/E04</i> <i>p. 38</i>	<i>E10/E11/E12</i> <i>p. 40</i>	<i>E13/E14</i> <i>p. 40</i>	<i>E15/E16</i> <i>p. 40</i>	<i>E20/E21</i> <i>p. 42</i>	<i>E23/E24</i> <i>p. 42</i>

Main specifications

MID: EN 50470 module B + D certification	• (E02)	• (E04)	• (E12)	• (E14)	• (E16)		• (E24)
RS485 Modbus		•		•			•
M-BUS					•		
Case	1 module	1 module	3 modules	3 modules	3 modules	4 modules	4 modules
Input voltage	230 VAC	230 VAC	230 VAC	230 VAC	230 VAC	230 ... 400 VAC	230 ... 400 VAC

Functions

Total/partial energy kWh	•/-	•/-	•/• (E10, E11)	•/-	•/-	•/•	•/•
Active power / Reactive power			•/-	•/•	•/•	•/-	
Dual tariff for kWh			• (E11, E12)	•	•	• (E21)	•
Total/partial energy kvarh							
kVA							
Load curve							
Measurement (I, V, P, Q, S, F and PF) via communication		•		•	•		•
CT connection indication				•	•		•
Bidirectional (energy consumption and production)				•	•		•

Accuracy

Active energy (IEC 62053-21)	class 1	class 1	class 1	class 1	class 1	class 1	class 1
Reactive power (according to IEC 62053-23)							
Active energy (EN 50470)	class B (E02)	class B (E04)	class B (E12)	class B (E14)	class B (E16)		class B (E24)

Characteristics

Metrological LED	•	•	•	•	•	•	•
Pulse output	100 Wh		100 Wh			100 Wh	
Sealing cover (MID version only)	• (E02)	• (E04)	• (E12)	• (E14)	• (E16)		• (E24)
Phase/neutral inversion protection						•	





(1) Does not include frequency measurement. - (2) Does not include frequency measurement, nor energy production metering.

Pulse concentrator	<i>COUNTIS ECi2</i> <i>p. 52</i>	<i>COUNTIS ECi3</i> <i>p. 52</i>
Case	4 modules	4 modules
Logical inputs	7	7
Analogue inputs		2
ON/OFF output (alarm)	1	1
Partial, total, daily, weekly or monthly kWh or other types of data (liters, m³...)	•	•
Load curve from 8 to 30 minutes	•	•
RS485 Modbus	•	•

Which accuracy?

MID certification?

Communication or pulse output?

Three-phase Direct up to 63 A	3 ph Direct up to 100 A			3 x Single-phase Direct up to 100 A	Three-phase CT/5 A			Three-phase CT/5 A	
									
E25/E26 p. 42	E30/E31/E32 p. 44	E33/E34 p. 44	E35/E36 p. 44	E63 p. 50	E40/E41/E42 p. 46	E43/E44 p. 46	E45/E46 p. 46	E50 p. 48	E53 p. 48
• (E26)	• (E32)	• (E34)	• (E36)		• (E42)	• (E44)	• (E44)		
		•		•		•			•
•			•				•		
4 modules	7 modules	7 modules	7 modules	7 modules	4 modules	4 modules	4 modules	96x96	96x96
230 ... 400 VAC	230 ... 400 VAC	230 ... 400 VAC	230 ... 400 VAC	230 ... 400 VAC	230 ... 400 VAC	230 ... 400 VAC	230 ... 400 VAC	86 ... 520 VAC	86 ... 520 VAC
•/•	•/• (E31)	• /via COM (E34)	• /via COM (E34)	•/•	•/•	• /via COM (E44)	• /via COM (E46)	•/•	•/•
	•/-	•/via COM	•/via COM	•/via COM	•/-	•/via COM	•/via COM	•/•	•/•
•	• (E31 /E32)	up to 4 via COM	up to 4 via COM	up to 4 via COM		up to 4 via COM	up to 4 via COM	•	•
		via COM	via COM	via COM		via COM	via COM	•	•
		via COM	via COM	via COM		via COM	via COM	•	•
		via COM	via COM	via COM		via COM	via COM		
•		via COM	via COM	via COM		via COM	via COM	•	•
					•	•	•	•	•
•		• (E33)	• (E35)			• (E43)	• (E45)		
class 1	class 1	class 1	class 1	class 1	class 0,5s	class 0,5s	class 0,5s	class 1	class 1
					class 2	class 2	class 2	class 2	class 2
class B (E26)	class B (E32)	class B (E34)	class B (E36)		class C (E42)	class C (E44)	class C (E46)		
•	•	•	•	•	•	•	•		
	100 Wh				configurable				
• (E26)	• (E32)	• (E34)	• (E36)		• (E42)	• (E44)	• (E46)		
	•	•	•	•	•	•	•	•	•

COUNTIS Eci pulse concentrator

Enables pulses from water, gas, compressed air, electricity meters or even analogue sensors (light, temperature, wind etc.) to be registered and stored. All data can be centralised and managed by an energy efficiency software via RS485 communication.

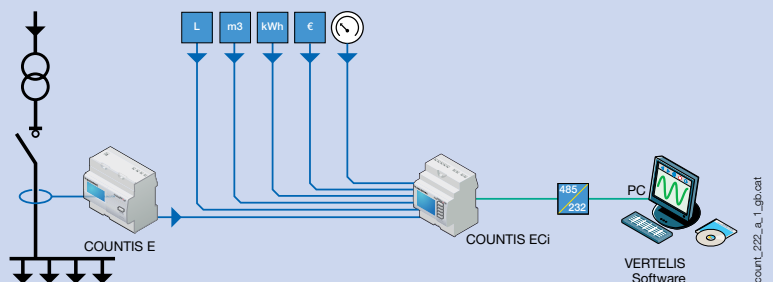



COUNTIS E0x

Active energy meters
single-phase - direct 32 A

Single-circuit metering,
measurement &
analysis

new



The solution for

- > Camping sites
- > Marinas
- > Shopping centres
- > Data centres



Strong points

- > Compact
- > Pulse output
- > MID certified B+D module
- > RS485 communication (MODBUS)

MID certification

- > COUNTIS E comply with the MID directive, guaranteeing accuracy and reliability when metering, an indispensable function for energy billing applications.
- > COUNTIS E MID feature tamper-proof components to prevent fraud.



Conformity to standards

- > IEC 62053-21 class 1
- > IEC 62053-31
- > IEC 62052-11
- > EN 50470-1
- > EN 50470-3



Function

The COUNTIS E0x is a modular active electrical energy meter displaying the total energy consumed (kWh) directly on its LCD display. It is designed for single-phase load metering and is used for direct connections of up to 32 A. The COUNTIS E02 and E04 has MID certification.

Advantages

Compact

The COUNTIS E0x is only 1 module wide.

Pulse output

The pulse output enables the kWh consumption to be reported to a remote system (PC/BMS) so that it can be analysed for billing, energy saving or energy cost management purposes.

MID certified B+D module

COUNTIS E products with MID certification provide the guaranteed accuracy required for applications in which sub-billing of the electrical energy consumed is necessary. "Module B+D" certification guarantees that the design and manufacturing process of products are approved by an accredited laboratory.

Principle diagram

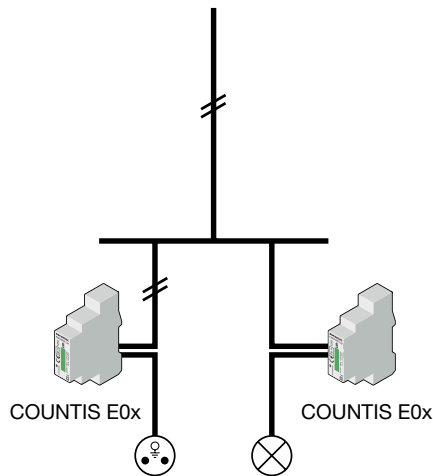

Common characteristics

- Compact design.
- Measurement accuracy: 1 %.
- LCD display.

Models	Key functions
E00	Pulse output
E02	MID + Pulse output
E03	MODBUS RS485 communication
E04	MODBUS RS485 communication + MID

Front panel

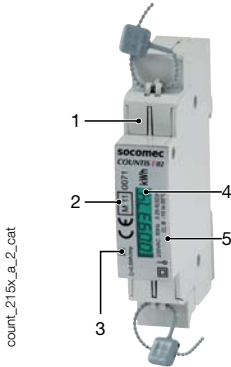

1. Terminal shrouds (COUNTIS E02 + E04).
2. MID Marking (COUNTIS E02 + E04).
3. Metrological LED (2000 pulses/kWh for E00/E02 and 1000 pulses/kWh for E03/E04)
4. kWh display.
5. Serial number (COUNTIS E02).

Electrical characteristics

Current measurement (TRMS)		Output (pulsed)	COUNTIS E00/E02
Type	single-phase - direct 32 A	Number	1
Input consumption	< 2 VA	Type of optocoupler	15 VDC max
Permanent overload	32 A	Fixed pulse weight	100 Wh
Intermittent overload	30 I _{max} for 10 ms	Pulse duration	100 ms
Minimum current measured	20 mA	Operating conditions	
Voltage measurements (TRMS)		Operating temperature	- 10 ... + 55 °C
Range of measurement	196 ... 264 VAC	Storage temperature	- 20 ... + 70 °C
Input consumption	8 VA	Relative humidity	95 %
Permanent overload	264 VAC	Communication	COUNTIS E03/E04
Energy accuracy		Link	RS485
Active (according to IEC 62053-21)	Class 1	Type	2 ... 3 half duplex wires
Active (according to EN 50470)	Class B	Protocol	MODBUS® RTU
Power supply		MODBUS speed	1200 ... 38400 bauds
Self-supplied	yes		

Case

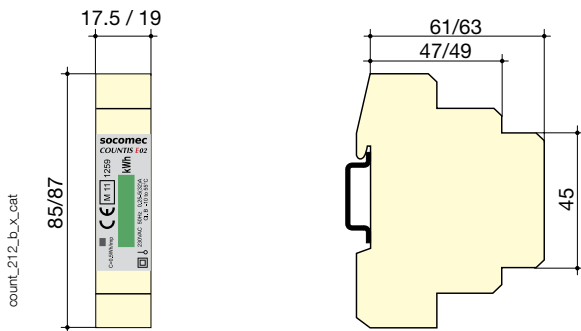

	COUNTIS E00/E02	COUNTIS E03/E04
Type	modular	modular
Number of modules	1	1
Dimensions W x H x D	17,5 x 85 x 61	19 x 87 x 63
Case degree of protection	IP 20	IP 20
Front degree of protection	IP 50	IP 50
Display type	LCD 5+1 digits	LCD 6+1 digits
Rigid cable cross-section	10 mm ²	6 mm ²
Flexible cable cross-section	6 mm ²	4 mm ²
Weight	150 g	150 g

Connection

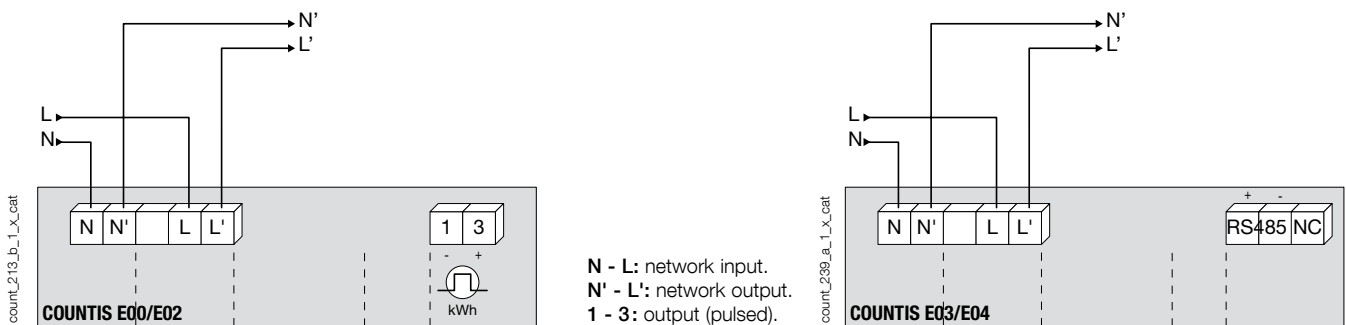

References

Type	COUNTIS E00 Reference	COUNTIS E02 Reference	COUNTIS E03 Reference	COUNTIS E04 Reference
Direct 32 A	4850 3019			
Direct 32 A - MID		4850 3020		
Direct 32 A - with MODBUS communication via RS485			4850 3029	
Direct 32 A - with MODBUS communication via RS485 - MID				4850 3030



COUNTIS E1x

Active energy meters

single-phase - direct 63/80 A

Single-circuit metering,
measurement &
analysis

new



The solution for

- > Marinas
- > Shopping centres
- > Data centres



Strong points

- > RS485 communication (MODBUS or M-BUS) or pulse output
- > Dual-tariff metering
- > MID certified B+D module

MID certification

- > COUNTIS E comply with the MID directive, guaranteeing accuracy and reliability when metering, an indispensable function for energy billing applications.
- > COUNTIS E MID feature tamper-proof components to prevent fraud.



Conformity to standards

- > IEC 62053-21 class 1
- > IEC 62053-31
- > IEC 62052-11
- > EN 50470-1
- > EN 50470-3



Function

The **COUNTIS E1x** is a modular active electrical energy meter displaying the energy and power consumed (kWh and kW) directly on its backlit LCD display. It is designed for single-phase load metering and is used for direct connections of up to 63 or 80 A depending on the model).

COUNTIS E12, E14 and E16 have MID certification.

Common characteristics

- Measurement accuracy: 1 %
- Backlit LCD display (only E10/E11/E12).

Advantages

RS485 communication (MODBUS or M-BUS) or pulse output

To enable the remote reporting of energy consumption, COUNTIS E1x are provided with either a pulse output or an RS485 communication output, with MODBUS or M-BUS protocol. In addition to their reporting functions, COUNTIS E1x with RS485 can be configured remotely and enable access to multi-measurement values.

Dual-tariff metering

Two tariffs are available and can be easily accessed through the meter's display. Each tariff can be utilised to assign energy metering to different time slots (high and low demand hours) or different sources (normal/backup).

Principle diagram

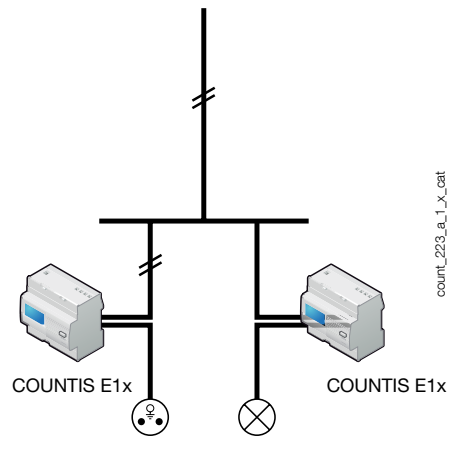

MID certified B+D module

COUNTIS E products with MID certification provide the guaranteed accuracy required for applications in which sub-billing of the electrical energy consumed is necessary. "Module B+D" certification guarantees that the design and manufacturing process of products are approved by an accredited laboratory.

Models	Key functions
E10	Pulse output
E11	Dual tariff (2 partial counters) + Pulse output
E12	Dual tariff + MID (Reset impossible) + Pulse output
E13	Dual tariff + MODBUS RS485 communication
E14	Dual tariff + MODBUS RS485 communication + MID (Reset impossible)
E15	Dual tariff + M-BUS communication
E16	Dual tariff + M-BUS communication + MID (Reset impossible)

Front panel

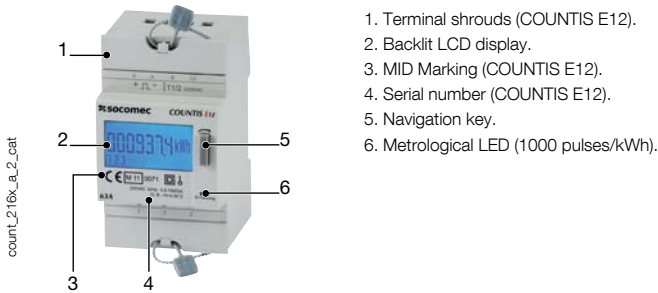

1. Terminal shrouds (COUNTIS E12).
2. Backlit LCD display.
3. MID Marking (COUNTIS E12).
4. Serial number (COUNTIS E12).
5. Navigation key.
6. Metrological LED (1000 pulses/kWh).

Electrical characteristics

Current measurement	COUNTIS E10...E12	COUNTIS E13...E16	Output (pulsed)	COUNTIS E10/E11/E12	
Type	single-phase direct 80 A	single-phase direct 80 A	Type of optocoupler	IEC 62053-31 Class A (20 ... 30 VDC)	
Input consumption	0.8 VA max.	0.8 VA max.	Number	1	
Startup current (I_{st})	40 mA	20 mA	Fixed pulse weight	100 Wh	
Minimum current (I_{min})	0.5 A ⁽¹⁾	0.25 A	Pulse duration	100 ms	
Transition current (I_t)	1 A ⁽²⁾	0.5 A	Operating conditions	COUNTIS E10...E12	COUNTIS E13...E16
Reference current (I_{ref})	10 A ⁽³⁾	5 A	Operating temperature	-10 to 55 °C	-25 to 55 °C
Permanent overload (I_{max})	63 A	80 A	Storage temperature	-20 to 70 °C	-25 to 70 °C
Intermittent overload	1890 A max for 10 ms	2400 A max for 10 ms	Relative humidity	85 %	85%
Voltage measurement			Communication	COUNTIS E13/E14	COUNTIS E15/E16
Range of measurement	230 V +/- 20 %	230 V +/- 20 %	Link	RS485	Connection
Consumption (VA)	0.5 VA max.	0.5 VA max.	Type	2 half duplex wires	2 half duplex wires
Permanent overload	280 V phase-neutral	300 V phase-neutral	Protocol	MODBUS® RTU	M-BUS
Energy accuracy			Speed	4800 ... 38400 bauds	300 ... 9600 bauds
Active (according to IEC 62053-21)	Class 1	Class 1			
Active (according to EN 50470)	Class B				
Power supply					
Self-supplied	yes				
Frequency	50/60 Hz				

(1) $I_{min} \leq 0.5 \cdot I_t$
 (2) The accuracy class is guaranteed between I_t and I_{max} .
 (3) $I_{ref} = I_{tr}$ (base current) = $10 \cdot I_{tr}$ for direct connection COUNTIS.

Case

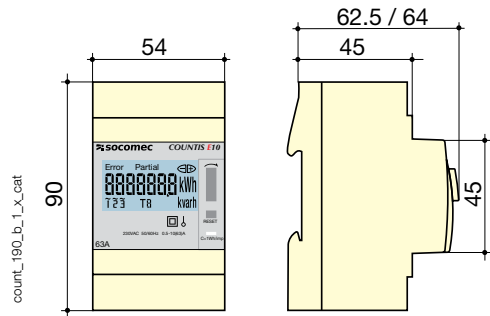

	COUNTIS E10...E12	COUNTIS E13...E16
Type	modular	modular
Number of modules	3	3
Dimensions W x H x D	54 x 90 x 62.5 mm	54 x 90 x 64 mm
Case degree of protection	IP 20	IP 20
Front degree of protection	IP 51	IP 51
Display type	Backlit LCD display	LCD display
Rigid cable cross-section	1.5 to 16 mm ²	7 to 50 mm ²
Flexible cable cross-section	1 to 16 mm ²	7 to 50 mm ²
Weight	170 g	170 g

Connection

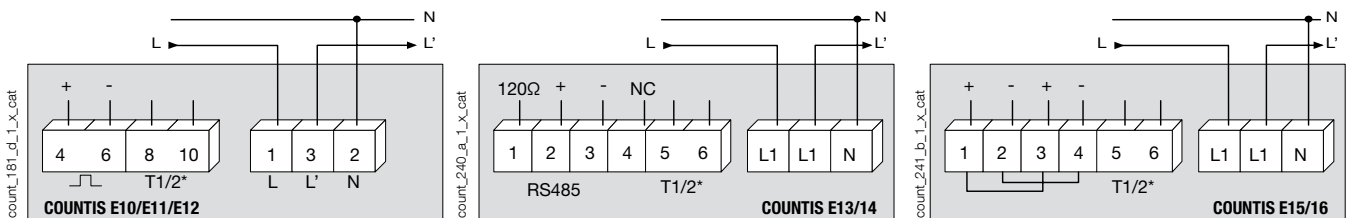

References

Type	COUNTIS E10 Reference	COUNTIS E11 Reference	COUNTIS E12 Reference	COUNTIS E13 Reference	COUNTIS E14 Reference	COUNTIS E15 Reference	COUNTIS E16 Reference
direct 63 A	4850 3000						
direct 63 A - Dual tariff		4850 3001					
direct 63 A - Dual tariff and MID			4850 3002				
direct 80 A - Dual tariff + MODBUS com. via RS 485				4850 3031			
direct 80 A - Dual tariff + MODBUS com. via RS 485 - MID					4850 3032		
direct 80 A - Dual tariff + M-BUS communication						4850 3033	
direct 80 A - Dual tariff + M-BUS communication - MID							4850 3034



COUNTIS E2x

Active energy meters
three-phase - direct 63 A

Single-circuit metering,
measurement &
analysis

new



COUNTIS E20

COUNTIS E23

The solution for

- > Industry
- > Infrastructure
- > Data centres



Strong points

- > RS485 communication (MODBUS or M-BUS) or pulse output
- > Dual-tariff metering
- > Detection of connection errors
- > MID certified B+D module

Conformity to standards

- > IEC 62053-21 class 1
- > IEC 62053-31
- > IEC 62052-11
- > EN 50470-1
- > EN 50470-3



MID certification

- > COUNTIS E comply with the MID directive, guaranteeing accuracy and reliability when metering, an indispensable function for energy billing applications.
- > COUNTIS E MID feature tamper-proof components to prevent fraud.



Services & Technical Assistance

- > Technical site audits and solution specification, commissioning, maintenance, training... Our Services & Technical Assistance experts offer you personalised support to ensure success with all your projects.

Function

The **COUNTIS E2x** is a modular active electrical energy meter displaying the energy and power consumed (kWh and kW) directly on its backlit LCD display. It is designed for three-phase load metering and is used for direct connections of up to 63 A.

Common characteristics

- Measurement accuracy: 1 %
- Backlit LCD display (only E20/E21)
- Detects connection errors

Advantages

RS485 communication (MODBUS or M-BUS) or pulse output

To enable the remote reporting of energy consumption, COUNTIS E2x are provided with either a pulse output or an RS485 communication output, with MODBUS or M-BUS protocol. In addition to their reporting functions, COUNTIS E2x with RS485 can be configured remotely and enable access to multi-measurement values.

Dual-tariff metering

Two tariffs are available and can be easily accessed through the meter's display. Each tariff can be utilised to assign energy metering to different time slots (high and low demand hours) or different sources (normal/back-up).

Detection of connection errors (E20/21)

The product is protected against phase/neutral inversion and detects wiring errors. This simplifies the installation and commissioning, thereby reducing associated costs, and ensures that the device operates correctly.

Principle diagram

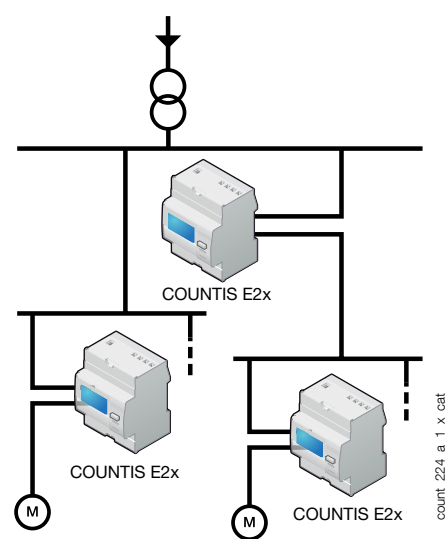

MID certified B+D module

COUNTIS E products with MID certification provide the guaranteed accuracy required for applications in which sub-billing of the electrical energy consumed is necessary. "Module B+D" certification guarantees that the design and manufacturing process of products are approved by an accredited laboratory.

Models	Key functions
E20	Pulse output
E21	Dual tariff (2 partial counters) + Pulse output
E23	Dual tariff + MODBUS RS485 communication
E24	Dual tariff + MODBUS RS485 communication + MID (Reset impossible)
E25	Dual tariff + M-BUS communication
E26	Dual tariff + M-BUS communication + MID (Reset impossible)

Front panel



1. Backlit LCD display.
2. Navigation key.
3. Reset key.
4. Metrological LED (1000 pulses/kWh).

Electrical characteristics

Current measurement	COUNTIS E20/E21	COUNTIS E23...E26
Type	three-phase direct 63 A	three-phase direct 63 A
Input consumption	0.8 VA max. per phase	0.8 VA max. per phase
Startup current (I_{st})	40 mA	15 mA
Minimum current (I_{min})	0.5 A ⁽¹⁾	0.25 A
Transition current (I_t)	1 A ⁽²⁾	0.5 A
Reference current (I_{ref})	10 A ⁽³⁾	5 A
Permanent overload (I_{max})	63 A	63 A
Intermittent overload	1890 A max for 10 ms	1890 A max for 10 ms
Voltage measurement		
Range of measurement	230 ... 400 V +/- 20 %	230 ... 400 V +/- 20 %
Consumption (VA)	2 VA max.	2 VA max.
Permanent overload	280 V phase-neutral / 480 V phase-phase	276 V phase-neutral
Energy accuracy		
Active (according to IEC 62053-21)	Class 1	
Active (according to EN 50470)	Class B	

(1) $I_{min} \leq 0.5 \cdot I_r$

(2) The accuracy class is guaranteed between I_t and I_{max} .

(3) $I_{ref} = I_{(b)}$ (base current) = $10 \cdot I_{(n)}$ for direct connection COUNTIS.

Power supply		
Self-supplied	yes	
Frequency	50 Hz	
Output (pulsed)	COUNTIS E20/E21	
Number	1	
Type of optocoupler	IEC 62053-31 Class A (20 ... 30 VDC)	
Fixed pulse weight	100 Wh	
Pulse duration	100 ms	
Operating conditions	E20 ... E21	E23 ... E26
Operating temperature	-10 to 55 °C	-25 to 55 °C
Storage temperature	-20 to 70 °C	-25 to 70 °C
Relative humidity	85 %	80 %
Communication	COUNTIS E23/E24	COUNTIS E25/E26
Link	RS485	Connection
Type	2 half duplex wires	2 half duplex wires
Protocol	MODBUS® RTU	M-BUS
Speed	1200 ... 38400 bauds	300 ... 9600 bauds

Case

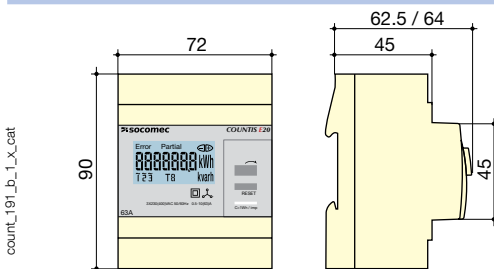

	COUNTIS E20/E21	COUNTIS E23...E26
Type	modular	modular
Number of modules	4	4
Dimensions W x H x D	72 x 90 x 62.5 mm	72 x 90 x 64 mm
Case degree of protection	IP20	IP20
Front degree of protection	IP51	IP51
Display type	Backlit LCD display	LCD display
Rigid cable cross-section	1.5 to 16 mm ²	1.5 to 35mm ²
Flexible cable cross-section	1 to 16 mm ²	1.5 to 35mm ²
Weight	245 g	245 g

Connection

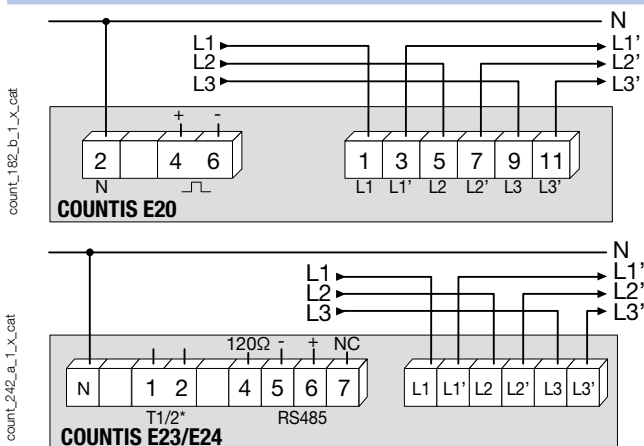

* Not available on COUNTIS E23

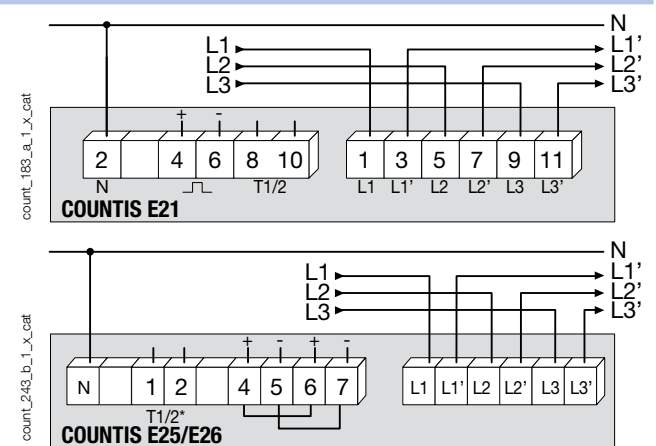

* Not available on COUNTIS E25

References

Type	COUNTIS E20 Reference	COUNTIS E21 Reference	COUNTIS E23 Reference	COUNTIS E24 Reference	COUNTIS E25 Reference	COUNTIS E26 Reference
direct 63 A - three-phase	4850 3003					
direct 63 A - three-phase - Dual tariff		4850 3004				
direct 63 A - Dual tariff with MODBUS com. via RS485			4850 3035			
direct 63 A - Dual tariff with MODBUS com. via RS485 - MID				4850 3036		
direct 63 A - Dual tariff with M-BUS communication					4850 3037	
direct 63 A - Dual tariff with M-BUS communication - MID						4850 3038



COUNTIS E3x

Active energy meters

three-phase - direct 100 A



COUNTIS E32 - MID

Single-circuit metering,
measurement &
analysis

Function

The **COUNTIS E3x** is a modular active electrical energy meter displaying the energy consumed and power consumed (kWh and kW) directly on its backlit LCD display. It is designed for three-phase load metering and is used for direct connections of up to 100 A.

COUNTIS E32, E34 and E36 are MID certified.

Common characteristics

- Measurement accuracy: 1 %
- Backlit LCD display.
- Detects connection errors.

Advantages

RS485 communication (MODBUS or M-BUS) or pulse output

To enable the remote reporting of energy consumption, COUNTIS E3x are provided with either a pulse output or an RS485 communication output, with MODBUS or M-BUS protocol.

In addition to their reporting functions, COUNTIS E3x with RS485 can be configured remotely and enable access to multi-measurement values.

Detection of connection errors

The product is protected against phase/neutral inversion and detects wiring errors. This simplifies the installation and commissioning, thereby reducing associated costs, and ensures that the device operates correctly.

Principle diagram

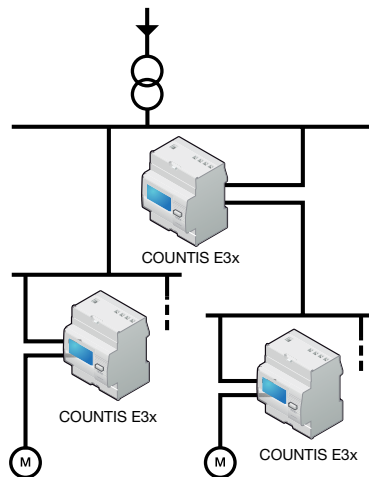

count_225_a_1_x_cat

MID certified B+D module

COUNTIS E products with MID certification provide the guaranteed accuracy required for applications in which sub-billing of the electrical energy consumed is necessary. "Module B+D" certification guarantees that the design and manufacturing process of products are approved by an accredited laboratory.

Bi-directional metering (available only on the E33 and E35)

This function is for metering energy production or energy consumption.

Multi-measurement and load curve

Display of electrical values (I, U, V, P, Q, S, PF) and load curve over a 7 day period via communication.

The solution for

- Industry
- Infrastructure
- Data centres



Strong points

- RS485 communication (MODBUS or M-BUS) or pulse output
- Detection of connection errors
- MID certified B+D module
- Bi-directional metering
- Multi-measurement and load curve

MID certification

- COUNTIS E comply with the MID directive, guaranteeing accuracy and reliability when metering, an indispensable function for energy billing applications.
- COUNTIS E MID feature tamper-proof components to prevent fraud.



Conformity to standards

- IEC 62053-21 class 1
- IEC 62053-31
- IEC 62053-11
- EN 50470-1
- EN 50470-3



Models	Key characteristics
E30	Pulse output
E31	Dual tariff (2 partial counters) + Pulse output
E32	Dual tariff + MID (Reset impossible) + Pulse output
E33	Dual tariff + RS485 MODBUS communication
E34	Dual tariff + RS485 MODBUS communication + MID (Reset impossible)
E35	Dual tariff + M-BUS communication
E36	Dual tariff + M-BUS communication + MID (Reset impossible)

Front panel



1. Terminal shrouds (COUNTIS E32, E34 and E36).
2. Backlit LCD display.
3. MID marking (COUNTIS E32, E34 and E36).
4. Serial number (COUNTIS E32, E34 and E36).
5. Navigation key.
6. Reset key.
7. Metrological LED.

Case

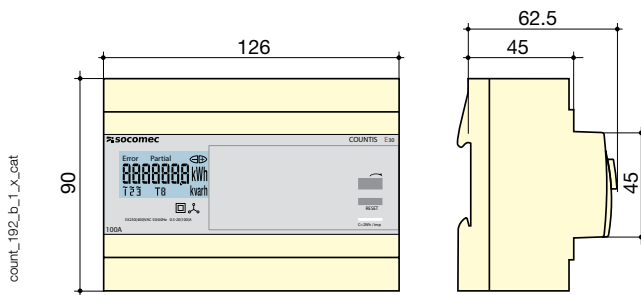

Type	modular
Number of modules	7
Dimensions W x H x D	126 x 90 x 62.5 mm
Case degree of protection	IP20
Front degree of protection	IP51
Display type	backlit LCD display
Rigid cable cross-section	2.5 to 35 mm ²
Flexible cable cross-section	2.5 to 35 mm ²
Weight	490 g

Electrical characteristics

Current measurement

Type	three-phase - direct 100 A
Input consumption	0.5 VA max. per phase
Startup current (I_{st})	80 mA
Minimum current (I_{min})	0.5 A ⁽¹⁾
Transition current (I_{tr})	2 A ⁽²⁾
Reference current (I_{ref})	20 A ⁽³⁾
Permanent overload (I_{max})	100 A
Intermittent overload	3000 A max for 10 ms

Voltage measurement

Range of measurement	230 ... 400 V +/- 20 %
Consumption (VA)	2
Permanent overload	280 V phase-neutral / 480 V phase-phase

Energy accuracy

Active (according to IEC 62053-21)	Class 1
Active (according to EN 50470)	Class B

Power supply

Self-supplied	yes
Frequency	50 / 60 Hz

Output (pulsed) (E30/E31/E32)

Number	1
Type of optocoupler	IEC 62053-31 class A (20 ... 30 VDC)
Fixed pulse weight	100 Wh
Pulse duration	100 ms

Operating conditions

Operating temperature	-10 to 55 °C
Storage temperature	-20 to 70 °C
Relative humidity	85 %

Communication

	E33/34	E35/E36
Link	RS485	Connection
Type	2 half duplex wires	2 half duplex wires
Protocol	MODBUS RTU	MBUS
Speed	4800 ... 38 400 bauds	300 ... 9600 bauds

(1) $I_{min} \leq 0.5 \cdot I_{tr}$

(2) The accuracy class is guaranteed between I_{tr} and I_{max} .

(3) $I_{ref} = I_{tr}$ (base current) = $10 \cdot I_{tr}$ for direct connection COUNTIS.

Connection

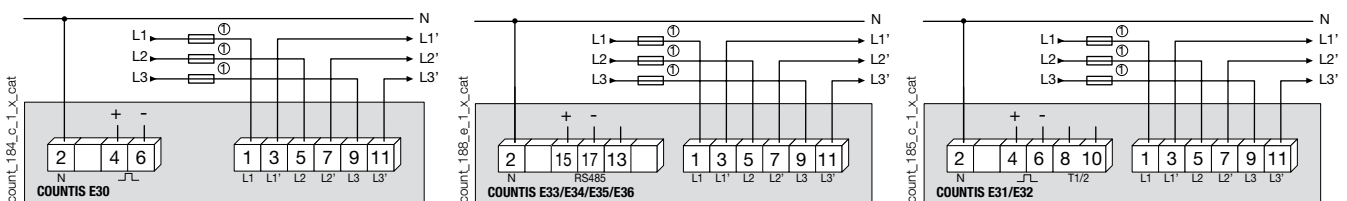

1. 100 A gG / Am fuses max.

References

Type	COUNTIS E30 Reference	COUNTIS E31 Reference	COUNTIS E32 Reference	COUNTIS E33 Reference	COUNTIS E34 Reference	COUNTIS E35 Reference	COUNTIS E36 Reference
100 A direct	4850 3005						
100 A direct - Dual tariff		4850 3006					
100 A direct - Dual tariff - MID			4850 3007				
100 A direct - Dual tariff with RS485 MODBUS communication ⁽¹⁾				4850 3012			
100 A direct - Dual tariff with RS485 MODBUS communication - MID ⁽¹⁾					4850 3013		
100 A direct - Dual tariff with M-BUS communication ⁽¹⁾						4850 3025	
100 A direct - Dual tariff with M-BUS communication - MID ⁽¹⁾							4850 3026
Management software for COUNTIS	See page 142						

(1) 4 tariffs through RS485 communication.



COUNTIS E4x

Active energy meters

three-phase - via CT up to 6000 A

Single-circuit metering, measurement & analysis



COUNTIS E44 - MID - (3000 A MID - 6000 A not MID)

Function

The **COUNTIS E4x** is a modular active and reactive electrical energy meter displaying the energies and active power consumed (kWh, kVArh and kW) directly on its backlit LCD display. It is designed for three-phase load metering with connection via CT and is suitable for applications of up to 6000 A (3000 A for MID).
COUNTIS E42, E44 and E46 are MID certified.

Common characteristics

- Measurement accuracy: 1 % / 0,5%(MID).
- Backlit LCD display.
- Detects connection errors.

Advantages

RS485 communication (MODBUS or M-BUS) or pulse output

To enable the remote reporting of energy consumption, COUNTIS E4x are provided with either a pulse output or an RS485 communication output, with MODBUS or M-BUS protocol.

In addition to their reporting functions, COUNTIS E4x with RS485 can be configured remotely and enable access to multi-measurement values.

Detection of connection errors

The product is protected against phase/neutral inversion and detects wiring errors. This simplifies the installation and commissioning, thereby reducing associated costs, and ensures that the device operates correctly.

Principle diagram

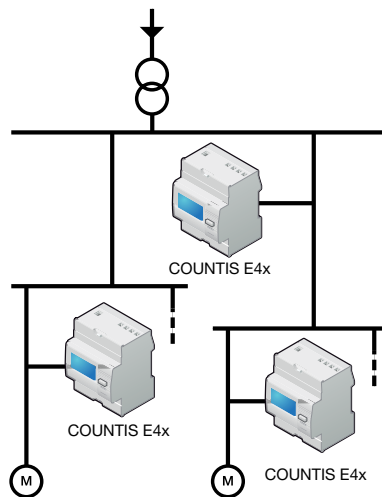

MID certified B+D module

COUNTIS E products with MID certification provide the guaranteed accuracy required for applications in which sub-billing of the electrical energy consumed is necessary. "Module B+D" certification guarantees that the design and manufacturing process of products are approved by an accredited laboratory.

Bi-directional metering (available on E43 and E45)

This function is for metering energy production or energy consumption.

Multi-measurement and load curve

Display of electrical values (I, U, V, P, Q, S, PF) and load curve over a 7 day period via communication.

The solution for

- > Industry
- > Infrastructure
- > Data centres



Strong points

- > RS485 communication (MODBUS or M-BUS) or pulse output
- > Detection of connection errors
- > MID certified B+D module
- > Bi-directional metering
- > Multi-measurement and load curve

MID certification

- > COUNTIS E comply with the MID directive, guaranteeing accuracy and reliability when metering, an indispensable function for energy billing applications.
- > COUNTIS E MID feature tamper-proof components to prevent fraud.



Conformity to standards

- > IEC 62053-21 class 1
- > IEC 62053-23 class 2
- > IEC 62053-31
- > IEC 62053-11
- > EN 50470-1
- > EN 50470-3



Models	Key functions
E40	Pulse output
E41	Dual tariff (2 partial counters) + Pulse output
E42	Dual tariff + MID (Reset impossible) + Pulse output
E43	Dual tariff + RS485 MODBUS communication
E44	Dual tariff + RS485 MODBUS communication + MID (Reset impossible)
E45	Dual tariff + M-BUS communication
E46	Dual tariff + M-BUS communication + MID (Reset impossible)

Front panel

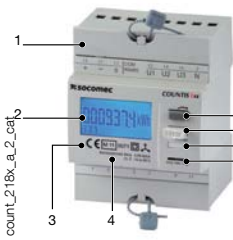

1. Terminal shrouds (COUNTIS E42, E44 and E46).
2. Backlit LCD display.
3. MID marking (COUNTIS E42, E44 and E46).
4. Serial number (COUNTIS E42, E44 and E46).
5. Navigation key.
6. Reset key.
7. Metrological LED.
8. Programming key.

Case

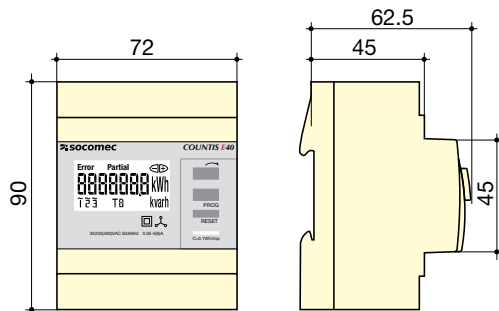

Type	modular
Number of modules	4
Dimensions W x H x D	73 x 90 x 62.5 mm
Case degree of protection	IP20
Front degree of protection	IP51
Display type	backlit LCD display
Rigid cable cross-section	1.5 to 10 mm ²
Flexible cable cross-section	1 to 6 mm ²
Weight	230 g

Electrical characteristics

Current measurement

Type	three-phase on CT/5A up to 6000 A (3000 A for MID products)
Input consumption	0.2 VA per phase
Startup current (I _{st})	10 mA
Minimum current (I _{min})	50 mA ⁽¹⁾
Transition current (I _{tr})	250 mA ⁽²⁾
Reference current (I _{ref})	5 A ⁽³⁾
Permanent overload (I _{max})	6 A
Intermittent overload	120 A for 0.5 s

Voltage measurement

Range of measurement	230 ... 400 V +/- 20 %
Consumption (VA)	2 VA
Permanent overload	280 V phase-neutral / 480 V phase-phase

Energy accuracy

Active (according to IEC 62053-21)	Class 0,5s
Active (according to EN 50470)	Class C (E42/44/E46)

Power supply

Self-supplied	yes
Frequency	50 / 60 Hz

Output (pulsed) (E40/E41/E42)

Number	1
Type of optocoupler	IEC 62053-31 Class A (20 ... 30 VDC)
Pulse weight	100 Wh, 1 kWh, 10 kWh, 100 kWh
Pulse duration	50 ms, 100 ms, 200 ms, 400 ms, 800 ms, 1000 ms, 1500 ms

Operating conditions

Operating temperature	-10 to 55 °C
Storage temperature	-20 to 70 °C
Relative humidity	85 %

Communication

	E43/E44	E45/E46
Link	RS485	Connection
Type	2 half duplex wires	2 half duplex wires
Protocol	MODBUS RTU	M-BUS
Speed	4800 ... 38400 bauds	300 ... 9600 bauds

(1) $I_{min} \leq 0.5 \cdot I_{tr}$

(2) The accuracy class is guaranteed between I_{tr} and I_{max} .

(3) $I_{ref} = I_{tr}$ (base current) = $10 \cdot I_{tr}$ for direct connection COUNTIS.

Connection

Recommendation:

- For IT earthing systems, it is recommended that the CT secondary is not connected to earth.
- When disconnecting the COUNTIS, the secondary of each current transformer must be short-circuited. This operation can be carried out automatically by a SOCOMEC PT1, an accessory which is included in this catalogue. Please consult us.

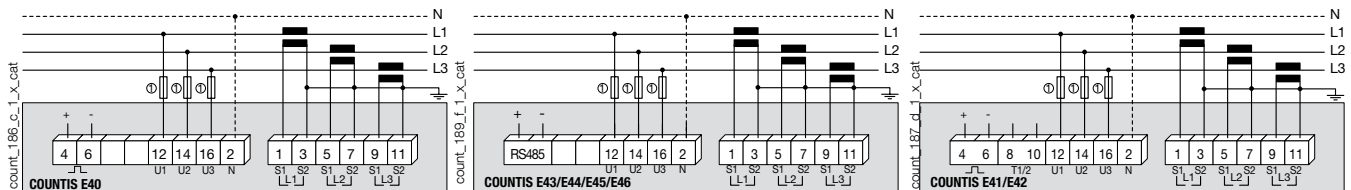

1. Fuses 0.5 A gG / 0.5 A class CC.

References

Type	COUNTIS E40 Reference	COUNTIS E41 Reference	COUNTIS E42 Reference	COUNTIS E43 Reference	COUNTIS E44 Reference	COUNTIS E45 Reference	COUNTIS E46 Reference
Via CT	4850 3008						
Via CT - Dual tariff		4850 3009					
Via CT - Dual tariff - MID			4850 3015				
Via CT - Dual tariff with RS485 MODBUS com. ⁽¹⁾				4850 3017			
Via CT - Dual tariff with RS485 MODBUS com. - MID ⁽¹⁾					4850 3014		
Via CT - Dual tariff with M-BUS com. ⁽¹⁾						4850 3027	
Via CT - Dual tariff with M-BUS com. - MID ⁽¹⁾							4850 3028
Management software for COUNTIS	See page 142						

(1) 4 tariffs through RS485 communication.



COUNTIS E5x

Active energy meters

three-phase - via CT up to 6000 A

Single-circuit metering,
measurement &
analysis



COUNTIS E53 up to 6000 A via CT

The solution for

- > Industry
- > Infrastructure
- > Data centres



Strong points

- > RS485 MODBUS communication or pulse output
- > Large backlit LCD display
- > Detection of connection errors
- > Direct display of multi-measurement and metering values

Conformity to standards

- > IEC 62053-23 class 2
- > IEC 62053-22 class 0.5S
- > IEC 61557-12



Management software

- > To get the most effective use from your Socomec measurement and metering devices, we offer a range of dedicated software tools. See page 142.

Function

The COUNTIS E5x is a panel mounted active and reactive electrical energy meter displaying energy and multi-measurement values directly on its large backlit LCD display. It is designed for utilisation on three-phase or single-phase networks with connection via CT and is suitable for applications of up to 6000 A. The CT ratio can be configured by the user via the keypad and the display, or via RS485 MODBUS communication (E53).

Common characteristics

- Measurement accuracy: 0.5%.
- Large backlit LCD display.
- Direct access to multi-measurement and metering values.
- Detects connection errors.

Advantages

RS485 MODBUS communication or pulse output

To enable the remote reporting of energy consumption, COUNTIS E5x are provided with either a pulse output (E50) or an RS485 MODBUS communication output (E53). Remote configuration of the Countis E53 is possible via RS485 MODBUS communication.

Detection of connection errors

The COUNTIS E5x is protected against phase/neutral inversion and has an integrated test function which can be utilised to detect wiring errors. This function enables CT installation errors to be corrected without having to remake connections. This simplifies the installation and commissioning, thereby reducing associated costs, and ensures that the device operates correctly.

Large backlit LCD display

Thanks to its large backlit LCD display and its multiple viewing screens with direct pushbutton access, COUNTIS E5x provide clear readings and are easy to use.

Principle diagram

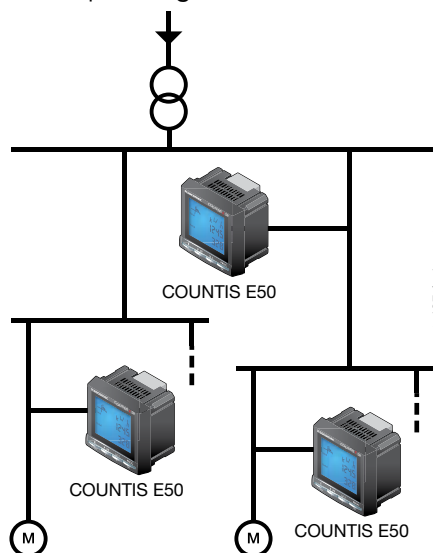

They directly display a number of total/partial metering and multi-measurement values : +/- kWh, +/- kvarh, kVAh, I, U, V, S, PF, etc.

Direct display of multi-measurement and metering values

Multi-measurement

- Currents: instantaneous: I1, I2, I3
- Voltages: instantaneous: V1, V2, V3, U12, U23, U31
- Power:
 - instantaneous: 3P, 3Q, 3S
 - maximum average: 3P
- Power factor:
 - instantaneous: 3PF

Metering

- Active energy: +/- kWh
- Reactive energy: +/- kvarh
- Apparent energy: kVAh

models	Key characteristics
E50	Pulse output
E53	RS485 MODBUS communication

References

Type	COUNTIS E50 Reference	COUNTIS E53 Reference
Pulse output	4850 3010	
RS485 MODBUS communication ⁽¹⁾		4850 3011
Management software for COUNTIS	See page 142	

(1) 4 tariffs through RS485 communication.

Electrical characteristics

Current measurement	
Type	three-phase on CT/5A up to 6000 A
Input consumption	< 0.6 VA
Startup current (I_{st})	40 mA
Minimum current (I_{min})	50 mA ⁽¹⁾
Transition current (I_t)	250 mA ⁽²⁾
Reference current (I_{ref})	5 A ⁽³⁾
Permanent overload (I_{max})	6 A
Intermittent overload	50 A for 1 s
Voltage measurement	
Range of measurement	86 ... 520 VAC
Input consumption	< 0.1 VA
Permanent overload	800 VAC
Energy accuracy	
Reactive (according to IEC 62053-23)	Class 2
Active (according to IEC 62053-22)	Class 0.5S
Power supply	
Self-supplied	no
Auxiliary power supply U_s	110 ... 400 VAC / 125 ... 350 VDC +/- 10 %
Frequency	45 ... 65 Hz
Output (pulsed)	
Number	1
Type	100 VDC - 0.5 A - 10 VA
Max. number of operations	$\leq 10^8$
Operating conditions	
Operating temperature	-10 ... 55 °C
Storage temperature	-20 ... 85 °C
Relative humidity	95 %
Communication	
Link	RS485
Type	2 ... 3 half duplex wires
Protocol	MODBUS RTU
MODBUS [®] speed	1400 ... 38400 bauds

Front panel



1. Backlit LCD display
2. Energy display and test function key
3. Power and power factor display key
4. Current and voltage display key
5. Programming mode access key

Case

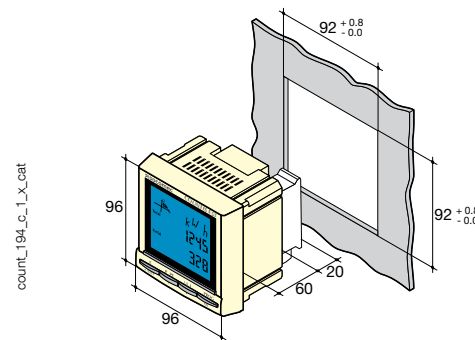

Type	Panel mounting
Dimensions W x H x D	96 x 96 x 80 mm
Case degree of protection	IP30
Front degree of protection	IP52
Display type	backlit LCD display
Voltage and current connection cross-section	0.5 ... 2.5 mm ²
Current connection cross-section	1.5 ... 6 mm ²
Weight	370 g

(1) $I_{min} \leq 0.5 \cdot I_t$

(2) The accuracy class is guaranteed between I_t and I_{max} .

(3) $I_{ref} = I_{(b)}$ (base current) = $10 \cdot I_{(b)}$ for direct connection COUNTIS.

Connection

Recommendation:

- For IT earthing systems, it is recommended that the CT secondary is not connected to earth.

- When disconnecting the COUNTIS, the secondary of each current transformer must be short-circuited. This operation can be carried out automatically by a SOCOMEC PTI, an accessory which is included in this catalogue. Please consult us.

Low voltage balanced network 3/4 wires with 1 CT

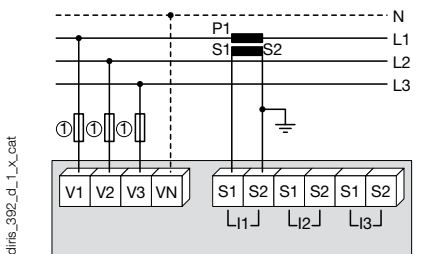

Use of 1 CT reduces by 0.5% the accuracy of the phases, the current of which is worked out by vector calculation.

Low voltage unbalanced network 3/4 wires with 3 CTs

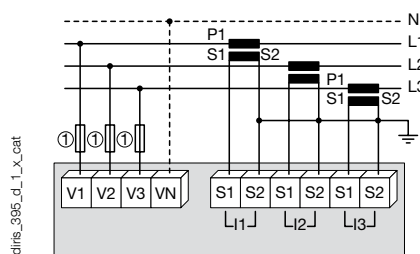

3 wires with 2 CTs

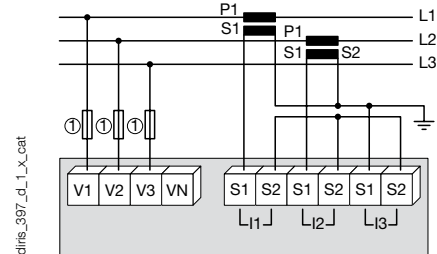

Use of 2 CT reduces by 0.5% the accuracy of the phases, the current of which is worked out by vector calculation.

Additional information

Communication via RS485 link

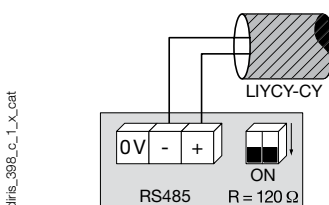

AC & DC auxiliary power supply

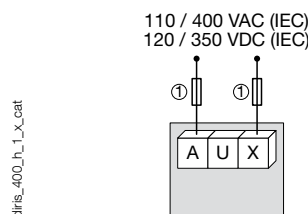

1. Fuses 0.5 A gG / 0.5 A class CC.



COUNTIS E63

Active energy meters

3 x single-phase - Direct 100 A

Single-circuit metering,
measurement &
analysis



COUNTIS E63

Function

The **COUNTIS E63** is a modular active electrical energy meter which provides metering for three single-phase loads, with direct connection of up to 100 A. It directly displays the total and partial energy and power (kWh and kW) consumed by each single-phase load.

Principle diagram

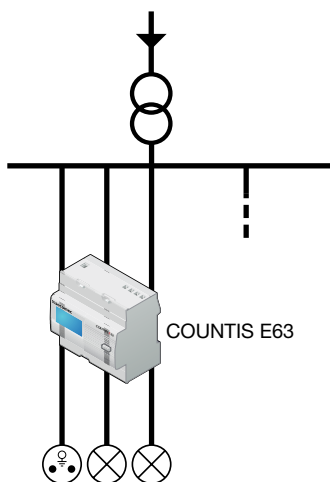

count_205_a_1_x_cat

Advantages

Compact

Due to the integration of three single-phase meters in the same case (7 modules wide), the COUNTIS E63 provides significant space-saving.

Advanced multi-measurement functions

Advanced multi-measurement functions are available via RS485 MODBUS communication:

- Instantaneous currents: I1, I2, I3
- Instantaneous voltages: V1, V2, V3
- Instantaneous power: 3P, 3S
- Instantaneous power factors: 3PF
- Load curves for each of the 3 phases:
Viewing of average positive active power consumption over a programmable period.

Detection of connection errors

The product is protected against phase/neutral inversion and detects wiring errors. This simplifies the installation and commissioning, thereby reducing associated costs, and ensures that the device operates correctly.

The solution for

- > Data centres
- > Infrastructure



Strong points

- > Compact
- > Advanced multi-measurement functions
- > Detection of connection errors

Conformity to standards

- > IEC 62053-21 class 1
- > IEC 62053-31
- > IEC 62053-11



Management software

- > To get the most effective use from your Socomtec measurement and metering devices, we offer a range of dedicated software tools. See page 142.

Front panel



1. Backlit LCD display
2. Navigation key
3. Reset key
4. Metrological LED

Electrical characteristics

Current measurement	
Type	3 x single-phase - direct 100 A
Input consumption	0.5 VA max. per phase
Startup current (I_{st})	80 mA
Minimum current (I_{min})	0.5 A
Transition current (I_t)	2 A
Reference current (I_{ref})	20 A
Permanent overload (I_{max})	100 A
Intermittent overload	3000 A max for 10 ms
Voltage measurement	
Range of measurement	230 ... 400 V +/- 20 %
Consumption on inrush (VA)	2
Permanent overload	280 V phase-neutral / 480 V phase-phase
Energy accuracy	
Active (according to IEC 62053-21)	Class 1

Power supply	
Self-supplied	yes
Frequency	50 / 60 Hz
Operating conditions	
Operating temperature	-10 to 55 °C
Storage temperature	-20 to 70 °C
Relative humidity	95 %
Communication	
Link	RS485
Type	2 ... 3 half duplex wires
Protocol	MODBUS RTU
MODBUS® speed	4800 ... 38400 bauds

Case

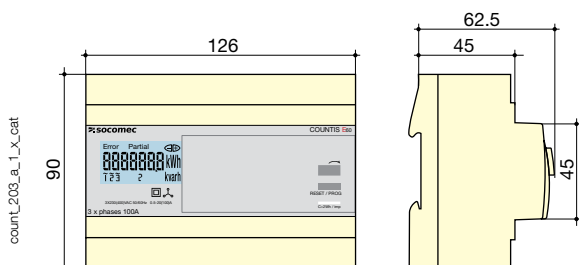

Type	modular
Number of modules	7
Dimensions W x H x D	126 x 90 x 62.5 mm
Case degree of protection	IP20
Front degree of protection	IP51
Display type	backlit LCD display
Rigid cable cross-section	2.5 to 35 mm ²
Flexible cable cross-section	2.5 to 35 mm ²
Weight	490 g

Connection

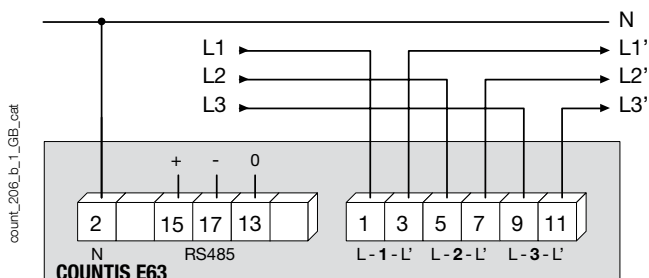

References

Type	3 x single phase - 100 A direct with RS485 MODBUS communication	COUNTIS E63 Reference 4850 3016
------	---	--



COUNTIS ECi_x

Multi-utility pulse concentrator

Single-circuit metering,
measurement &
analysis



COUNTIS ECi3

The solution for

- > Data centres
- > Industry
- > Infrastructure



Strong points

- > Up to 7 multi-utility meters and 2 analogue sensors
- > Load curves
- > RS485 MODBUS communication
- > Improved customisation

Management software

- > To get the most effective use from your Socomec measurement and metering devices, we offer a range of dedicated software tools. See page 142.

Function

The **COUNTIS ECi_x** is a multi-utility pulse concentrator which communicates via an RS485 link using MODBUS protocol.

It enables pulses from water, gas, compressed air, electricity meters and, for the COUNTIS ECi3, the output of analogue sensors (light, temperature, wind etc.) to be registered and stored. All data, ie. total and partial meters and load curves (available for all logical and analogue inputs) can be centralised via RS485 communication using MODBUS protocol.

Principle diagram

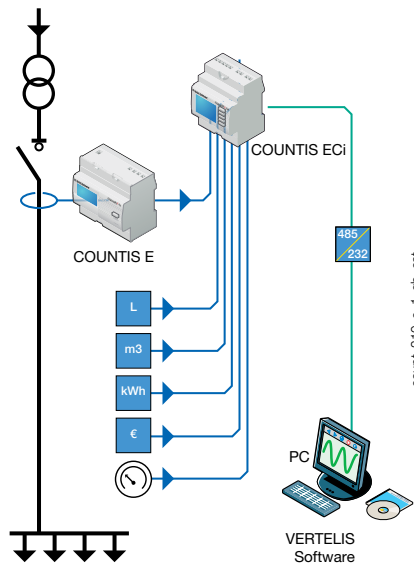

Advantages

Up to 7 multi-utility meters and 2 analogue sensors

- 7 logical inputs + 2 analogue inputs.
- Total, partial and programmable metering (day, week, month, year).

Load curves

Load curves are available for each of the 7 logical inputs.

A history of average values are available for the 2 analogue inputs (ECi3).

RS485 MODBUS communication

- Centralisation and transmission of pulse and analogue data to a supervision station.
- Remote configuration of COUNTIS ECi device.

Improved customisation

- Selection of the measuring unit: kWh, m³, liters.
 - Selection of the currency unit: €, K€, £, \$.
- Values can be displayed in the unit of your choice and energy costs can be directly calculated.

Models	Key characteristics
ECi2	7 insulated inputs
ECi3	7 insulated inputs + 2 analogue inputs.

Front panel

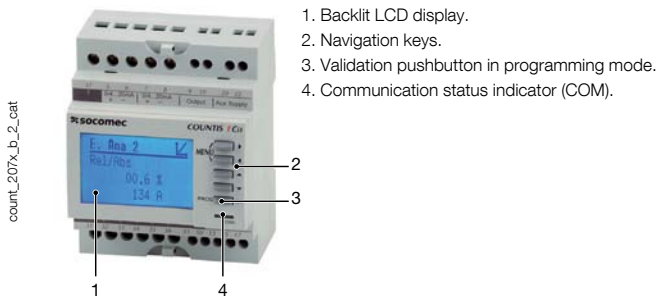

Case

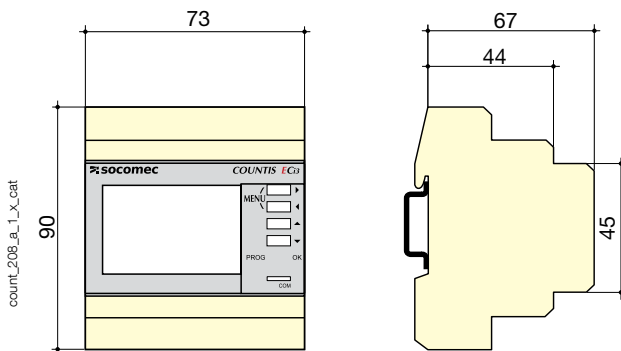

Type	modular
Number of modules	4
Dimensions W x H x D	73 x 90 x 67 mm
Case degree of protection	IP20
Front degree of protection	IP51
Display type	backlit LCD display
Terminal blocks type	fixed
Rigid cable cross-section	1... 10 mm ²
Flexible cable cross-section	0.5... 6 mm ²
Weight	215 g

Characteristics

Auxiliary power supply

Self-supplied	no
Alternating voltage	110 / 400 VAC
Direct voltage	120 / 300 VDC
Tolerance	± 10 %
Frequency	45 / 65 Hz
Consumption	5 VA
Insulation voltage	3.5 kV

Communication

Link	RS485
Type	2 ... 3 half duplex wires
Protocol	MODBUS RTU
MODBUS [®] speed	9600... 38400 bauds

Inputs

Number	7
Control voltage (integrated)	10...30 VDC
Minimum signal width	10 ms
Maximum signal width	2 s
Minimum duration between 2 pulses	30 ms
Edge triggering	rising

Analogue inputs (ECi3)

Number	2
Current	25 mA
Accuracy	0.5 %
Response time	500 ms
Input resistance	200 Ω
Consumption	0.1 VA

Operating conditions

Operating temperature	-10... +55 °C
Storage temperature	-20... +70 °C
Relative humidity	95 %

Connection

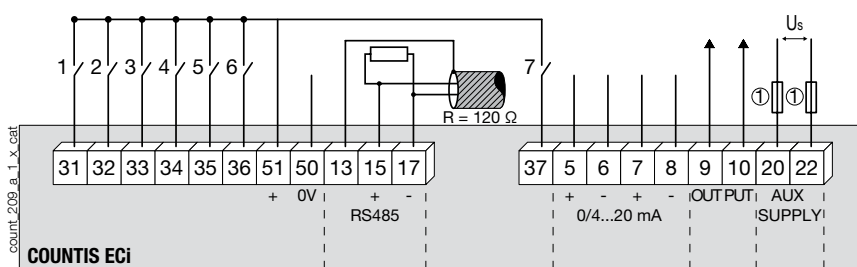

- 31 : logical input n°1.
- 32 : logical input n°2.
- 33 : logical input n°3.
- 34 : logical input n°4.
- 35 : logical input n°5.
- 36 : logical input n°6.
- 37 : logical input n°7.

- 13-15-17 : RS485 link.
- 5-6 : Analogue input n°1.
- 7-8 : Analogue input n°2.
- 9-10 : output.
- 20-22 : power supply
U=110...400 VAC ± 10 %.

51-50 : Inputs internal/
external power supply.

References

Auxiliary power supply U_s	COUNTIS ECi2 Reference	COUNTIS ECi3 Reference
230 / 400 VAC	4853 0000	
230 / 400 VAC + 2 analogue inputs		4853 0001
Description of accessories	Reference	Reference
Panel mounting kit	192J 8015	192J 8015
Management software for COUNTIS	See page 142	



Selection guide

Multifunction meters

DIRIS

Single-circuit metering,
measurement &
analysis

Which application?







Which functions?

Application	Multifunction metering (PMD)			
	 <i>DIRIS A10</i> <i>p. 56</i>	 <i>DIRIS A14</i> <i>p. 60</i>	 <i>DIRIS A17</i> <i>p. 64</i>	 <i>DIRIS A20</i> <i>p. 68</i>
Multi-measurement				
Currents, voltages (ph/ph and ph/n), active/reactive/apparent powers, power factor, frequency	•	•	•	•
4 th CT for neutral current measurement				
Voltage/current unbalance				
Currents, voltages, frequency (average values)	(max. average value for currents)	(max. average value for currents)	(max. average value for currents)	(max. average value for currents)
Max. power demand	•	•	•	•
Temperatures	Internal			
Tangent phi		• cos phi		
Hour meter	•			•
Memorisation of min/max instantaneous values		•		
Metering				
MID: EN 50470 module B + D certification		•		
kWh (+/-), kvarh (+/-)	kWh (+), kvarh (+)	•	•	kWh (+), kvarh (+)
Logical input(s) for pulse meter(s)			1 as standard	
Multi-tariff meters	•	•		
Pulse output(s)	1 as standard		1 as standard	with optional module
Active energy accuracy / IEC 62053-21 class 1			•	
Active energy accuracy / IEC 62053-22 class 0.5 s	•	•		•
Active energy accuracy / IEC 62053-22 class 0.2 s				
Active energy (EN 50470)		Class C		
Reactive energy accuracy / IEC 62053-23 class 2	•	•	•	•
Compatibility with IEC 61557-12	•	•	•	•
Power management				
Load curves (period 5, 8, 10, 15, 20 and 30 minutes)		•		
Predictive power				
Power quality				
THD voltages, currents and neutral currents	Row 51	Row 63	Row 31 (if option available)	Row 51
Individual harmonics				
Interharmonics				
Vector diagram				
Flicker				
EN 50160				
Sag, swell and outages, overcurrent				
RMS 1/2 period curve backup for events				
Management of fault currents				
Plug-in modules				
	<ul style="list-style-type: none"> • 1 logical input as standard • 1 logical output as standard • Modbus as standard for 1 reference 			<ul style="list-style-type: none"> • 1 logical output • Modbus RS485 communication • 3 In / 1 out + alarm

Which dimensions?

Which communication protocol?

Which options?

	Power monitoring (PMD)		Power monitoring & events analysis (PMD)	Power monitoring & residual current monitoring (PMD+RCM)	Power quality & network analysis (PQA)
					
	DIRIS A40 <i>p. 72</i>	DIRIS A41 <i>p. 72</i>	DIRIS A60 <i>p. 78</i>	DIRIS A80 <i>p. 84</i>	DIRIS N <i>p. 88</i>
	•	•	•	•	•
		•		•	•
	•	•	•	•	•
	•	•	•	•	•
	by temperature sensor PT100	by temperature sensor PT100	by temperature sensor PT100		internal + by temperature sensor
	•	•	•	•	•
	optional	optional	•	•	•
	•	•	•	•	•
	up to 6 with optional module	up to 6 with optional module	up to 6 with optional module		optional
					•
	up to 6 with optional module	up to 6 with optional module	up to 6 with optional module		optional
	•	•	•	•	•
					•
	•	•	•	•	•
	•	•	•	•	•
	optional	optional	•	•	•
	•	•	•	•	•
	Row 63	Row 63	Row 63	Row 63	Row 51
	Row 63	Row 63	Row 63	Row 63	Row 51
					•
					•
			•	•	•
			•	•	•
			•	•	•
				•	
	<ul style="list-style-type: none"> • 2 pulse outputs • Modbus RS485 communication • PROFIBUS DP communication • Ethernet communication (available with Modbus gateway) • 2 analogue outputs • 2 inputs / 2 outputs • Memory • Temperature inputs 		<ul style="list-style-type: none"> • Memory fitted as standard • 2 pulse outputs • Modbus RS485 communication • Ethernet communication (available with Modbus gateway) • 2 analogue outputs • 2 inputs / 2 outputs • Temperature inputs 	<ul style="list-style-type: none"> • Modbus RS485 communication • Ethernet communication (available with Modbus gateway) 	<ul style="list-style-type: none"> • 4 digital inputs / 2 digital outputs • 2 analogue inputs • 2 analogue outputs



DIRIS A10

Multifunction meters - PMD
Modular multifunction meter

Single-circuit metering,
measurement &
analysis



DIRIS A10

diris_791_c_1_cat

The solution for

- > Industry
- > Infrastructures
- > Data centres



Strong points

- > Easy to use
- > Integrated temperature sensor
- > Detects wiring errors
- > Compliant with IEC 61557-12

Conformity to standards

- > IEC 61557-12
- > IEC 62053-22 class 0.5S
- > IEC 62053-23 class 2



Function

The **DIRIS A10** is a modular multifunction meter for measuring electrical values in low voltage networks. It allows all electrical parameters to be displayed and utilised for communication and/or output functions.

Advantages

Easy to use

Five direct access pushbuttons enable all measurements to be clearly viewed on its backlit LCD display.

Integrated temperature sensor

It allows variations in temperature to be detected.

Detects wiring errors

An integrated test function can be utilised to detect incorrect wiring and to automatically correct CT installation errors.

Compliant with IEC 61557-12

IEC 61557-12 is a high-level standard for all PMDs (Performance Monitoring Devices) that are designed to measure and monitor electrical parameters in distribution networks. Compliance with IEC 61557-12 ensures a high level of equipment performance, in terms of metrology, and the mechanical and environmental aspects (EMC, temperature, etc.).

Principle diagram

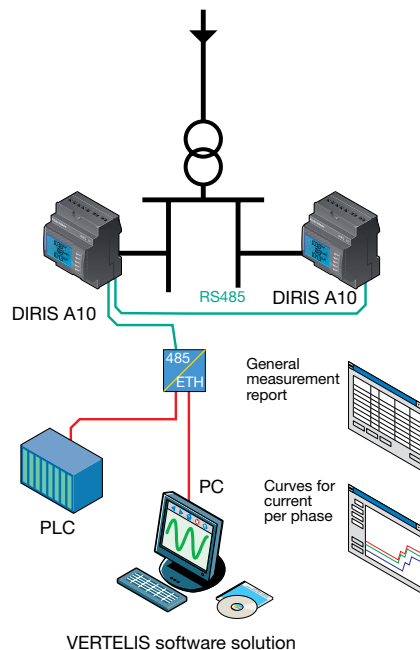

diris_808_L1_lgb_cat

Functions

Multi-measurement

- Currents
 - instantaneous: I1, I2, I3, In
 - maximum average: I1, I2, I3, In
- Voltages & frequency
 - instantaneous: V1, V2, V3, U12, U23, U31, F
- Power
 - instantaneous: 3P, ΣP, 3Q, ΣQ, 3S, ΣS
 - maximum average: ΣP, ΣQ, ΣS
- Power factors
 - instantaneous: 3PF, ΣPF

Metering

- Active energy: + kWh
- Reactive energy: + kVarh
- Hours: ⌚
- Harmonic analysis
 - Total harmonic distortion (level 51)
 - Currents: thd I1, thd I2, thd I3
 - Phase-to-neutral voltage: thd V1, thd V2, thd V3
 - Phase-to-phase voltage: thd U12, thd U23, thd U31

Dual tariff function

Selection of one out of 2 billing tariffs

Events

Alarms on all electrical values

Communications⁽¹⁾

RS485 with MODBUS protocol

Input

- Tariff selection
- Remote device status

Output

- Remote command of device
- Alarm report
- Pulse report

⁽¹⁾ Available on specific version (see the following pages).

Front panel



1. Backlit LCD display.
2. Direct access key for currents (instant and maximum), current THD and test function.
3. Direct access key for voltages, frequency and voltage THD.
4. Direct access key for active, reactive and apparent power (instantaneous and max. values) and power factor.
5. Direct access key for energies.
6. Pushbutton for hour meter, temperature and programming menu access.
7. Metrological LED.

Case

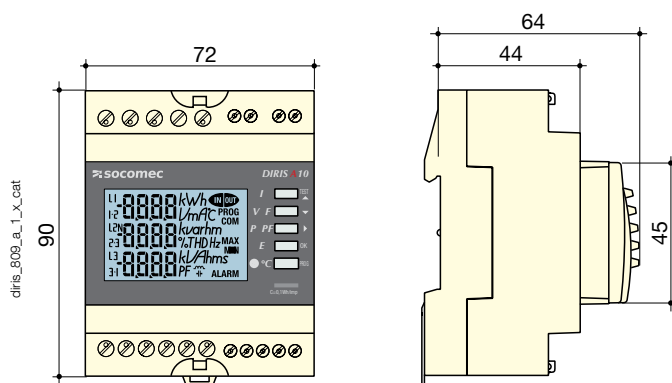

Type	modular
Number of modules	4
Dimensions W x H x D	72 x 90 x 64 mm
Case degree of protection	IP 30
Front degree of protection	IP 52
Display type	backlit LCD display
Voltage and current connection cross-section	4 mm ²
Connection cross-section for AUX supply, input, output and comms.	2.5 mm ²
Weight	205 g (4825 0010) - 215 g (4825 0011)

Electrical characteristics

Current measurement (TRMS)	
Via CT primary	9 999 A
Via CT secondary	5 A
Measurement range	0 ... 11 kA
Input consumption	0.6 VA
Measurement updating period	1 s
Accuracy	0.2 %
Permanent overload	6 A
Intermittent overload	10 I _n for 1 s
Voltage measurements (TRMS)	
Direct measurement between phases	50 ... 500 VAC
Direct measurement between phase and neutral	28 ... 289 VAC
Input consumption	≤ 0.1 VA
Measurement updating period	1 s
Accuracy	0.2 %
Permanent overload	800 VAC
Power measurement	
Measurement updating period	1 s
Accuracy	0.5 %
Power factor measurement	
Measurement updating period	1 s
Accuracy	0.5 %
Frequency measurement	
Measurement range	45 ... 65 Hz
Measurement updating period	1 s
Accuracy	0.1 %

Energy accuracy	
Active (according to IEC 62053-22)	Class 0.5 S
Reactive (according to IEC 62053-23)	Class 2
Metrological LED (EA*)	
Pulse weight	10000 pulses/kWh
Colour	Red
Auxiliary power supply	
Alternating voltage	110 ... 277 VAC
AC tolerance	± 15 %
Frequency	50 / 60 Hz
Consumption	< 3 VA
Digital output (pulses or on/off)	
Number	1
Type	20 / 30 VDC - 0.5 A - 10 VA
Max. number of operations	≤ 10 ⁸
Input (tariff)	
Number	1
Type	0 VAC: T1 / 200-277 VAC: T2
Communication	
Link	RS485
Type	2 ... 3 half duplex wires
Protocol	MODBUS RTU
MODBUS® speed	2400 ... 38400 bauds
Operating conditions	
Operating temperature	- 10 ... + 55 °C
Storage temperature	- 20 ... + 70 °C
Relative humidity	85 %

DIRIS A10

Multifunction meters - PMD
Modular multifunction meter

Connection

Recommendation:

- For IT earthing systems, it is recommended that the CT secondary is not connected to earth.
- When disconnecting the DIRIS, the secondary of each current transformer must be short-circuited. This operation can be carried out automatically by a SOCOMEC PT1, an accessory which is included in this catalogue. Please consult us.
- It is recommended that the earthing point for the DIRIS A10 and the current transformer secondaries are not earthed at the same time.

Low voltage balanced network

3/4 wires with 1 CT

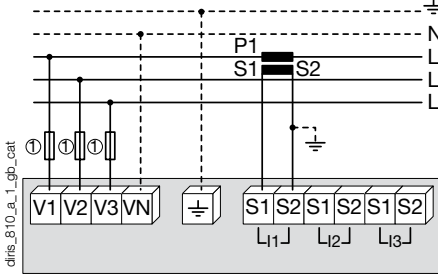

1. Fuses 0.5 A gG / 0.5 A class CC.

Single-phase

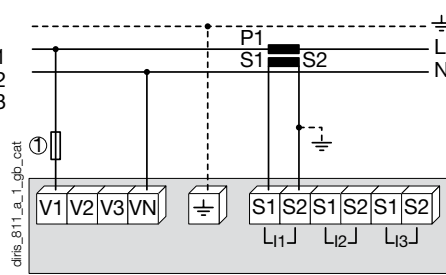

1. Fuses 0.5 A gG / 0.5 A class CC.

Two-phase

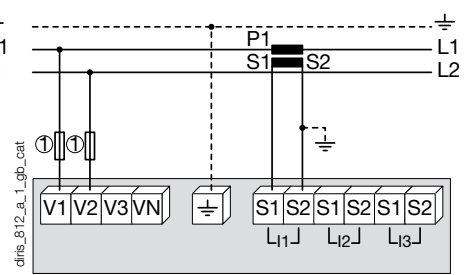

1. Fuses 0.5 A gG / 0.5 A class CC.

Low voltage unbalanced network

3/4 wires with 3 CTs

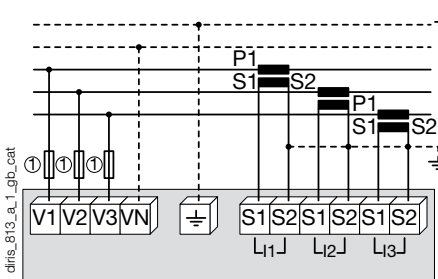

1. Fuses 0.5 A gG / 0.5 A class CC.

3 wires with 2 CTs

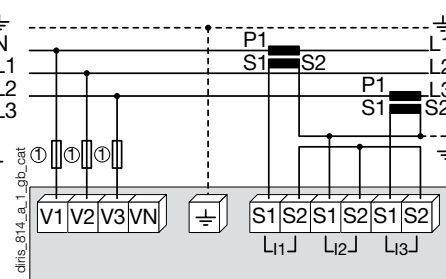

Use of 2 CTs reduces by 0.5% the accuracy of the phases, the current of which is worked out by vector calculation.
1. Fuses 0.5 A gG / 0.5 A class CC.

3 wires with 2 CTs

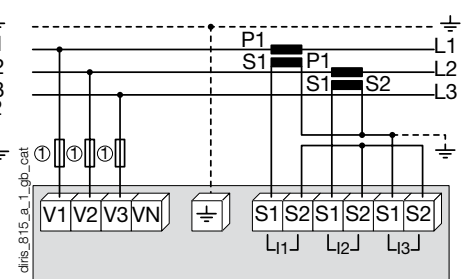

Use of 2 CTs reduces by 0.5% the accuracy of the phases, the current of which is worked out by vector calculation.
1. Fuses 0.5 A gG / 0.5 A class CC.

Additional information

Communication via RS485 link

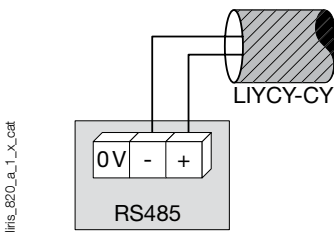

diris_b20_a_1_x_cat

AC auxiliary power supply

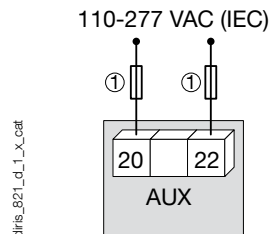

diris_b21_d_1_x_cat

1. Fuses 0.5 A gG / 0.5 A class CC.

Terminals

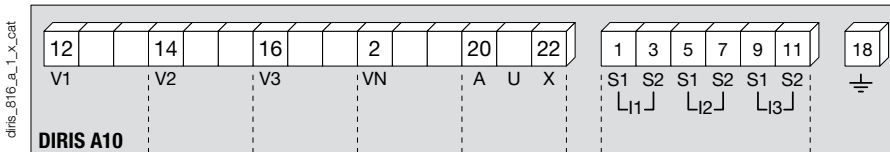

AUX: auxiliary power supply U_s .
V1, V2, V3 & VN: voltage inputs.

S1 - S2: current inputs.

Communication terminals

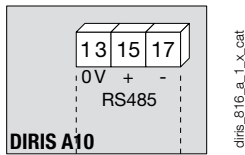

RS485 link.

Pulse or alarm output terminals

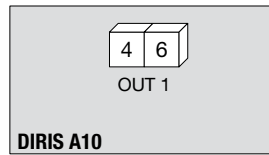

4 - 6: output n°1

Input terminals

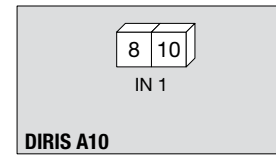

8 - 10: input n°1

References

Basic device		DIRIS A10
Description		Reference
DIRIS A10 (available in light grey on request)		4825 0010
DIRIS A10 with RS485 MODBUS communication (available in light grey on request)		4825 0011
Description of accessories	To be ordered in multiples of	Reference
Fuse disconnect switches for the protection of voltage inputs (type RM) 3 poles	4	5601 0018
Fuse disconnect switches for the protection of the auxiliary supply (type RM) 1 pole + neutral	6	5601 0017
Fuses type gG 10x38 0.5 A	10	6012 0000
Current transformer range	1	See page 98
Management software for DIRIS		See page 142

Services & Technical Assistance

- Technical site audits and solution specification, commissioning, maintenance, training... Our Services & Technical Assistance experts offer you personalised support to ensure success with all your projects.





DIRIS A14

Multifunction meters - PMD
Modular multifunction meter - MID

new



DIRIS A14

Single-circuit metering,
measurement &
analysis

Function

The **DIRIS A14** is a modular multifunction meter for measuring electrical values in low voltage networks. It allows all electrical parameters to be displayed and utilised for communication and/or output functions.

Advantages

MID certified B+D module

DIRIS A14 products with MID certification provide the guaranteed accuracy required for applications in which sub-billing of the electrical energy consumed is necessary. "Module B+D" certification guarantees that the design and manufacturing process of products are approved by an accredited laboratory.

Bi-directional metering (four quadrants)

This function is for metering energy production or energy consumption.

Multi-measurement and load curve.

Display of electrical values (I, U, V, ΣP , ΣQ , ΣS , PF) and P+ load curve over a 7 day period via communication.

Functional diagram

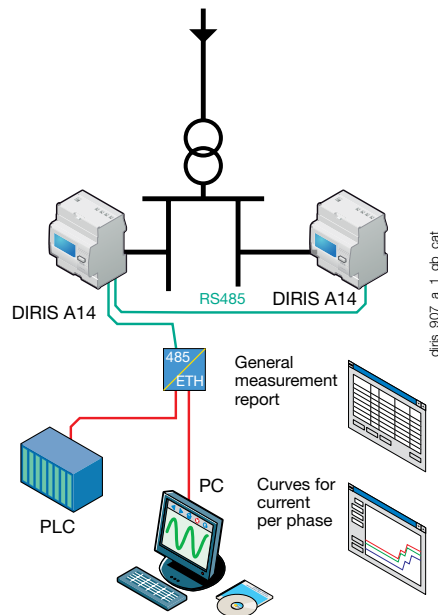

VERTELIS software solution

Compliant with IEC 61557-12

IEC 61557-12 is a high-level standard for all PMDs (Performance Monitoring Devices) that are designed to measure and monitor electrical parameters in distribution networks. Compliance with IEC 61557-12 ensures a high level of equipment performance, in terms of metrology, and the mechanical and environmental aspects (EMC, temperature, etc.).

The solution for

- > Industry
- > Infrastructures
- > Data centre



Strong points

- > MID certified B+D module
- > Bi-directional metering
- > Multi-measurement and load curves
- > Compliant with IEC 61557-12
- > Detection of connection errors

Conformity to standards

- > IEC 61557-12
- > IEC 62053-23 class 2
- > EN50470-1
- > EN50470-3 class C



Detection of connection errors

The product is protected against phase/neutral inversion and detects wiring errors

Functions

Multi-measurement

- Currents
 - instantaneous: I1, I2, I3, In
 - maximum average: I1, I2, I3, In
- Voltages
 - instantaneous: V1, V2, V3, U12, U23, U31
- Power
 - instantaneous: ΣP , ΣQ , ΣS
 - maximum average: ΣP , ΣQ , ΣS
- Power factor ($\cos \varphi$)
 - instantaneous: $\Sigma \cos \varphi$
 - maximum average: $\Sigma \cos \varphi$

Total and partial metering

- Active energy: + kWh, - kWh
- Reactive energy: + kvarh, - kvarh

Harmonic analysis (via communication)

- Total harmonic distortion (level 63)
 - Currents: thd I1, thd I2, thd I3
 - Phase-to-neutral voltage: thd V1, thd V2, thd V3
 - Phase-to-phase voltage: thd U12, thd U23, thd U31

Multi tariff function (via communication)

Selection of one out of 4 billing tariffs

Events (via communication)

- Active energy consumption: day n-1 / week n-1 / month n-1
- Active power load curve: P 10 minutes over 7 days with time-log

Communications

RS485 with MODBUS protocol

Front panel

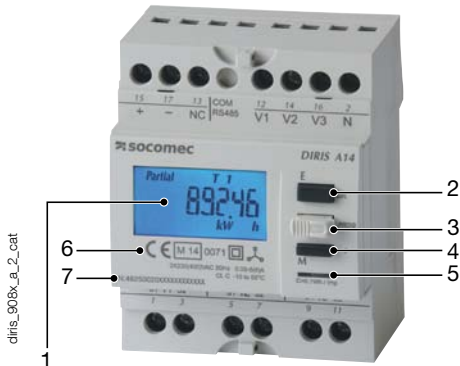

1. Backlit LCD display.
2. Direct access for energies and validation key.
3. Programming key.
4. Navigation key for measurements.
5. Metrological LED
6. MID marking.
7. Serial Number.

Case

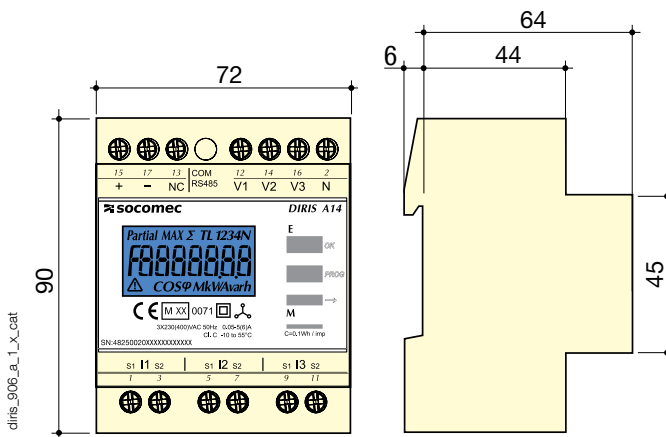

Type	modular
Number of modules	4
Dimensions W x H x D	72 x 90 x 64 mm
Case degree of protection	IP20
Front degree of protection	IP51
Display type	Backlit LCD
Rigid cable cross-section	1.5 to 10 mm ²
Flexible cable cross-section	1 to 6 mm ²
Weight	240 gr

Electrical characteristics

Current measurement (TRMS)	
Via CT primary	10 to 2500 A
Via CT secondary	5 A
Input consumption	0.6 VA
Startup current (I_{st})	5 mA
Minimum current (I_{min})	50 mA
Transmission current (I_{tr})	250 mA
Reference current (I_{ref})	5 A
Measurement updating period	1 s
Accuracy	0,5 %
Permanent overload	6 A
Intermittent overload	120 A for 0.5 s
Voltage measurements (TRMS)	
Direct measurement (four phases)	50 to 460 VAC +/- 15%
Input consumption	2 VA
Measurement updating period	1 s
Accuracy	0,2 %
Permanent overload	480 V (phase-to-phase measurement)
Power measurement	
Measurement updating period	1 s
Accuracy	0.5 %
Power factor measurement (cos φ)	
Measurement updating period	1 s
Accuracy	0.01

Energy accuracy	
Active (according to IEC 62053-22)	Class 0.5 S
Reactive (according to IEC 62053-23)	Class 2
Active (according to EN 50470)	Class C
Metrological LED (EA*,EA*)	
Pulse weight	10000 pulses/kWh
Colour	Red
Auxiliary power supply	
Self-supply	Yes
Frequency	50 / 60 Hz
Communication	
Link	RS485
Type	2 ... 3 half duplex wires
Protocol	MODBUS RTU
MODBUS® speed	4800 ... 38400 bauds
Operating conditions	
Operating temperature	- 10 ... + 55 °C
Storage temperature	- 20 ... + 70 °C
Relative humidity	95% without condensation

DIRIS A14

Multifunction meters - PMD

Modular multifunction meter - MID

Connection

Low voltage balanced network

Recommendation:

- For IT earthing systems, it is recommended that the CT secondary is not connected to earth.

- When disconnecting the DIRIS, the secondary of each current transformer must be short-circuited.

This operation can be carried out automatically by a SOCOMEC PTI, which can be found in the SOCOMEC catalogue: please consult us.

3/4 wires with 1 CT

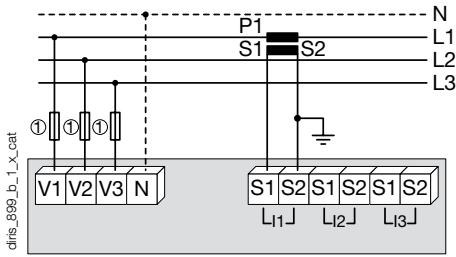

1. Fuses 0.5 A gG / 0.5 A class CC.

Single-phase

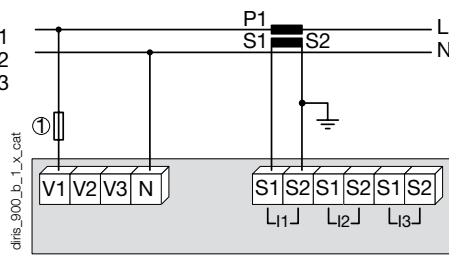

1. Fuses 0.5 A gG / 0.5 A class CC.

Two-phase

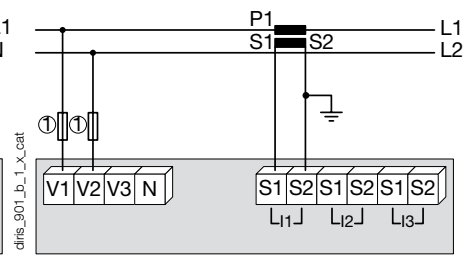

1. Fuses 0.5 A gG / 0.5 A class CC.

Low voltage unbalanced network

3/4 wires with 3 CTs

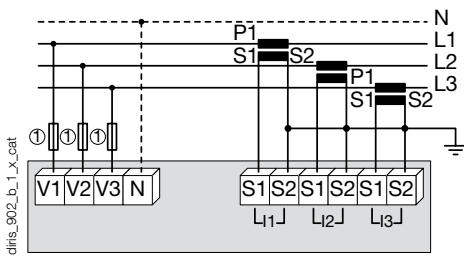

1. Fuses 0.5 A gG / 0.5 A class CC.

Additional information

Communication via RS485 link

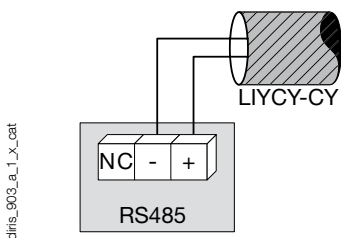

Terminals

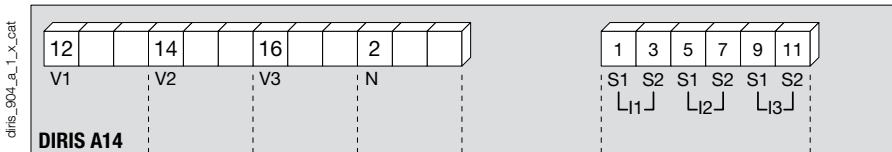

V1, V2, V3 & N: voltage inputs.

S1 - S2: current inputs.

Communication module

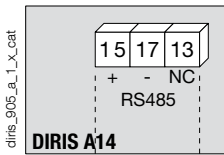

RS485 link.

References

Basic device	DIRIS A14
Description	Reference
DIRIS A14 MID + RS485 MODBUS communication	4825 0020
Accessories	Reference
Panel mounting kit	4825 0070

Services & Technical Assistance

- > Our expertise extends to a complete offer of customised services, such as technical site audit and solution specification, commissioning, training, maintenance, and project engineering.





DIRIS A17

Multifunction meters - PMD

Multi-measurement meter - dimensions 72x72 mm - LV/HV

new

Single-circuit metering,
measurement &
analysis



DIRIS A17

The solution for

- > Industry
- > Infrastructure
- > Non critical buildings



Strong points

- > Compact
- > Compliant with IEC 61557-12
- > User friendly
- > Advanced functionalities

Conformity to standards

- > IEC 61557-12
- > IEC 62053-21 class 1
- > IEC 62053-23 class 2



Management software

- > To get the most effective use from your Socomec measurement and metering devices, we offer a range of dedicated software tools. See page 142.

Function

Compact and ergonomic, the **DIRIS A17** is a multifunction meter specially adapted for monitoring and managing electrical energy. Its communication function allows the use and analysis of data collected via a PLC or VERTELIS energy management software. The DIRIS A17 is a key tool for all your energy efficiency projects.

Advantages

Compact

The 72 x 72 mm compact, surface-mounted format allows easy integration into any type of electrical cabinet configuration.

Compliant with IEC 61557-12

IEC 61557-12 is a high-level standard for all PMDs (Performance Monitoring Devices) that are designed to measure and monitor electrical parameters in distribution networks.

Compliance with IEC 61557-12 ensures a high level of equipment performance, in terms of metrology, and the mechanical and environmental aspects (EMC, temperature, etc.).

User friendly

As well as being compact, the DIRIS A17 also allows easy navigation via its 4 direct access keys. Its screen displays a large amount of information, whilst remaining easy to read.

Functional diagram

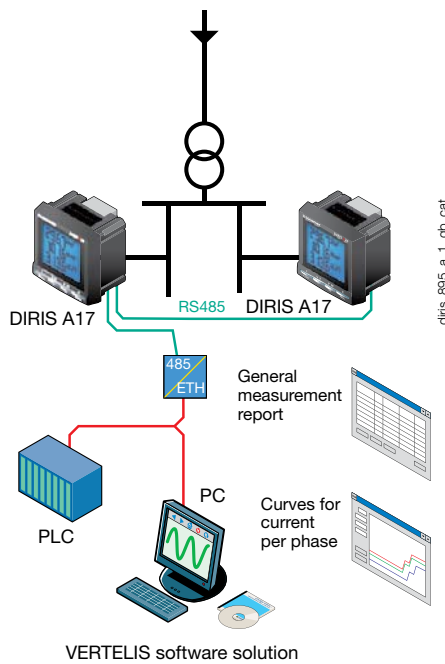

Advanced functionalities

The DIRIS A17 offers input/output functions as standard and has a pulse output or RS485 MODBUS communication output.

Functions

Multi-measurement

- Currents
 - instantaneous: I1, I2, I3, In
 - maximum average: I1, I2, I3, In
- Voltages & frequency
 - instantaneous: V1, V2, V3, U12, U23, U31, f
- Power
 - instantaneous: 3P, ΣP, 3Q, ΣQ, 3S, ΣS
 - maximum average: ΣP, ΣQ, ΣS
- Power factors
 - instantaneous: 3PF, ΣPF

Metering

- Active energy: +/- kWh
- Reactive energy: +/- kvarh

Harmonic analysis

- Total harmonic distortion (level 31)
 - Currents: thd I1, thd I2, thd I3, thd In
 - Phase-to-neutral voltage: thd V1, thd V2, thd V3, (4 wire network)
 - Phase-to-phase voltage: thd U12, thd U23, thd U31, (3 wire networks)

Events

Alarms on all electrical values

Communications

RS485 with MODBUS protocol

Input

- Pulsed Input
- Data report via external dry contact

Output

- Remote command of device
- Alarm report
- Pulse report

Front panel



1. Backlit LCD display.
2. Direct access key for currents (instantaneous and maximum) and current THD.
3. Direct access key for voltages, frequency and voltage THD.
4. Pushbutton for active, reactive, and apparent power (instantaneous and max. values) and power factor.
5. Direct access key for energies.

Case

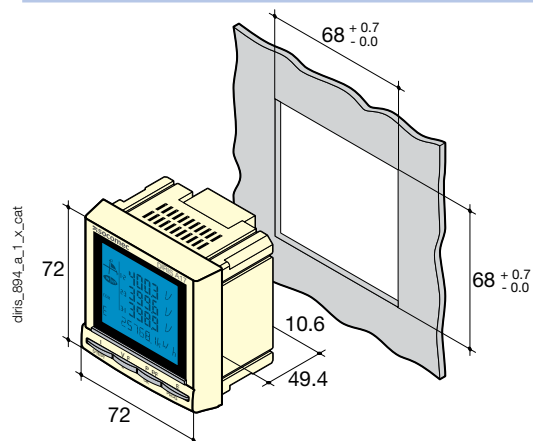

Type	Panel mounting
Dimensions W x H x D	72 x 72 x 60 mm
Case degree of protection	IP30
Front degree of protection	IP52
Display type	Backlit LCD
Terminal block type	fixed or plug-in
Voltage and other connection cross-section	0.2 ... 2.5 mm ²
Current connection cross-section	0.5 ... 6 mm ²
Weight	400 g

Accessories

Current transformers
(see page 98)

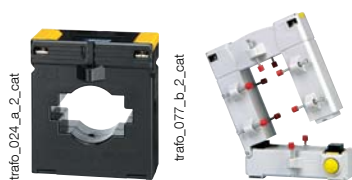

DIRIS A17

Multifunction meters - PMD

Multi-measurement meter - dimensions 72x72 mm - LV/HV

Electrical characteristics

Current measurement (TRMS)	
Via CT primary	9 999 A
Via CT secondary	1 or 5 A
Measurement range	0 ... 11 kA
Input consumption	0.6 VA
Measurement updating period	1 s
Accuracy at 50 Hz	0.5 %
Accuracy at 60 Hz	1 %
Permanent overload	6 A
Intermittent overload	10 I _n for 1 s
Voltage measurements (TRMS)	
Direct measurement between phases	50 ... 500 VAC
Direct measurement between phase and neutral	28 ... 289 VAC
VT primary	400 000 VAC
VT secondary	60, 100, 110, 173, 190 VAC
Input consumption	≤ 0.1 VA
Measurement updating period	1 s
Accuracy at 50 Hz	0.5 %
Accuracy at 60 Hz	1 %
Permanent overload	800 VAC
Power measurement	
Measurement updating period	1 s
Accuracy at 50 Hz	1 %
Accuracy at 60 Hz	2 %
Power factor measurement	
Measurement updating period	1 s
Accuracy at 50 Hz	0.5 %
Accuracy at 60 Hz	1 %
Frequency measurement	
Measurement range	45 ... 65 Hz
Measurement updating period	1 s
Accuracy	0.1 %

Energy accuracy	
Active (according to IEC 62053-21) at 50 Hz	class 1
Active (according to IEC 62053-21) at 60 Hz	class 2
Reactive (according to IEC 62053-23)	class 2
Operating conditions	
Operating temperature	- 10 ... + 55 °C
Storage temperature	- 20 ... + 85 °C
Relative humidity	95 %
Auxiliary power supply	
AC voltage	220 ... 277 VAC
AC tolerance	± 15 %
Frequency	50 / 60 Hz
Consumption	3 VA
Digital, pulse, command input	
Number	1
Type	optocoupler 8 to 30 VDC
Minimum signal width	10 ms
Minimum duration between 2 pulses	18 ms
Communication	
Link	RS485
Type	2 ... 3 half duplex wires
Protocol	MODBUS RTU
MODBUS® speed	1200 ... 38400 bauds
Pulse, alarm and control output	
Number	1
Power supply	8 to 30 VDC
Minimum signal width	10 ms
Minimum duration between 2 pulses	18 ms
Type of optocoupler	IEC 62053-31 Class A (5 ... 30 VDC)
Pulse weight	100 Wh, 1 kWh, 10 kWh, 100 kWh, 1000 kWh, 10000 kWh
Pulse length	100 ms, 200 ms, 300 ms, ..., 900 ms

Terminals

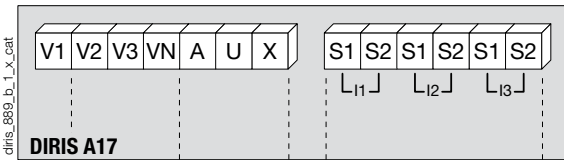

S1 - S2: current inputs.

AUX: Auxiliary power supply.

V1, V2, V3 & VN: voltage inputs.

Communication

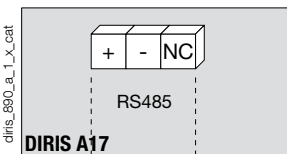

Input/output

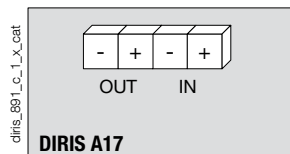

2 inputs

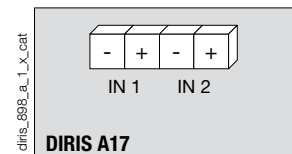

Connection

Recommendation:

- For IT earthing systems, it is recommended that the CT secondary is not connected to earth.
- When disconnecting the DIRIS, the secondary of each current transformer must be short-circuited. This operation can be carried out automatically by a SOCOMEC PTI, which can be found in the SOCOMEC catalogue: please consult us.

Low voltage balanced network

3/4 wires with 1 CT

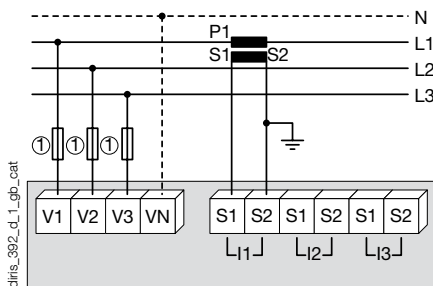

Low voltage unbalanced network

3 wires with 2 CTs

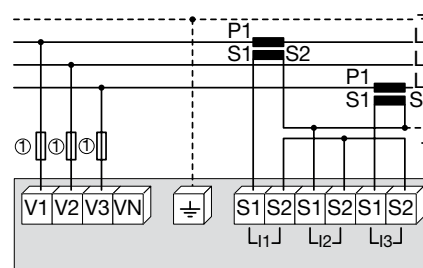

Use of 2 CTs reduces by 0.5% the accuracy of the phases, the current of which is worked out by vector calculation.

3 wires with 2 CTs

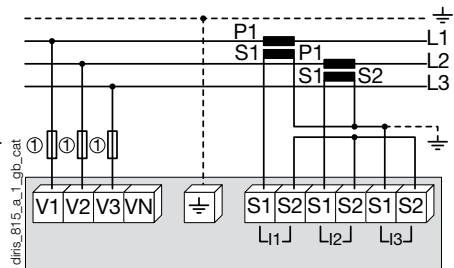

Use of 2 CTs reduces by 0.5% the accuracy of the phases, the current of which is worked out by vector calculation.

Low voltage unbalanced network

3/4 wires with 3 CTs

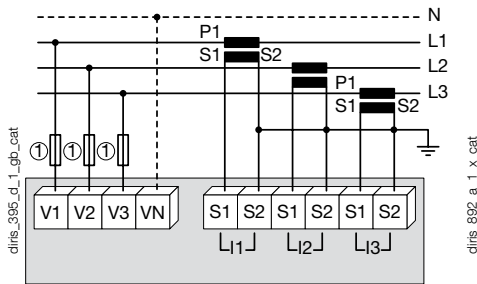

1. Fuses 0.5 A gG / 0.5 A class CC.

Additional information

Communication via RS485 link

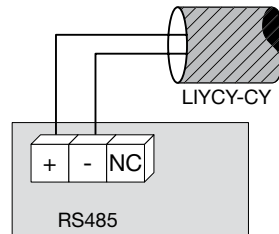

AC auxiliary power supply

AUX Supply 230VAC

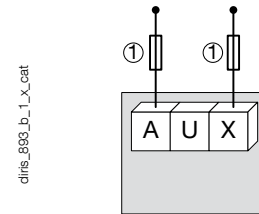

1. Fuses 0.5 A gG / 0.5 A class CC.

References

Basic device		DIRIS A17
Auxiliary power supply U_s		Reference
220 ... 277 VAC with pulse output		4825 0101
220 ... 277 VAC with MODBUS communication via RS485		4825 0102
220 ... 277 VAC with MODBUS communication via RS485 + THD		4825 0103
220 ... 277 VAC with MODBUS communication via RS485 + 2 inputs		4825 0104
220 ... 277 VAC with MODBUS communication via RS485 + 2 inputs + THD		4825 0105
Accessories		Reference
Description of accessories	To be ordered in multiples of	Reference
Fuse disconnect switches for the protection of voltage inputs (type RM) 3 poles	4	5601 0018
Fuse disconnect switches for the protection of the auxiliary supply (type RM) 1 pole + neutral	6	5601 0017
Fuses type gG 10x38 0.5 A	10	6012 0000
Current transformer range	1	See page 98
Management softwares for DIRIS		See page 142

Services & Technical Assistance

- Our expertise extends to a complete offer of customised services, such as technical site audit and solution specification, commissioning, training, maintenance, and project engineering.





DIRIS A20

Multifunction meters - PMD

Multi-measurement meter - dimensions 96 x 96 mm

Single-circuit metering,
measurement &
analysis



DIRIS A20

The solution for

- > Industry
- > Infrastructure
- > Data centres



Strong points

- > Easy to use
- > Compliant with IEC 61557-12
- > Detects wiring errors

Conformity to standards

- > IEC 61557-12
- > IEC 62053-22 class 0.5S
- > IEC 62053-23 class 2



Management software

- > To get the most effective use from your Socomec measurement and metering devices, we offer a range of dedicated software tools. See page 142.

Function

DIRIS A20 are panel mounted measurement units which ensure the user has access to all the measurements required for successfully carrying out energy efficiency projects and ensuring the electrical distribution is monitored.

All this information can be analysed remotely using the VERTELIS software solution.

Advantages

Easy to use

Thanks to its large backlit LCD display and its multiple viewing screens with direct pushbutton access, DIRIS A20 provide clear readings and are easy to use.

They directly display a number of multi-measurement and metering values : + kWh, + kvarh, I, U, V, F, P, Q, S, PF, etc.

Compliant with IEC 61557-12

IEC 61557-12 is a high-level standard for all PMDs (Performance Monitoring Devices) that are designed to measure and monitor electrical parameters in distribution networks. Compliance with IEC 61557-12 ensures a high level of equipment performance, in terms of metrology, and the mechanical and environmental aspects (EMC, temperature, etc.).

Principle diagram

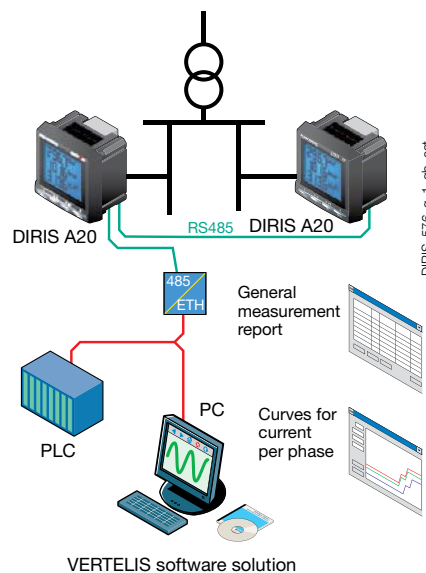

Detects wiring errors

An integrated test function can be utilised to detect incorrect wiring and to automatically correct CT installation errors.

Functions

Multi-measurement

- Currents
 - instantaneous: I1, I2, I3, In
 - maximum average: I1, I2, I3, In
- Voltages & frequency
 - instantaneous: V1, V2, V3, U12, U23, U31, F
- Power
 - instantaneous: 3P, ΣP, 3Q, ΣQ, 3S, ΣS
 - maximum average: ΣP, ΣQ, ΣS
- Power factors
 - instantaneous: 3PF, Σ

Metering

- Active energy: + kWh
- Reactive energy: + kvarh
- Hours: ⌚

Harmonic analysis

- Total harmonic distortion (level 51)
 - Currents: thd I1, thd I2, thd I3
 - Phase-to-neutral voltage: thd V1, thd V2, thd V3
 - Phase-to-phase voltage: thd U12, thd U23, thd U31

Events

Alarms on all electrical values

Communications⁽¹⁾

RS485 with MODBUS protocol

Output

- Remote command of device
- Alarm report
- Pulse report

Inputs

- Remote status device

⁽¹⁾ Available as an option (see the following pages).

Front panel



1. Backlit LCD display.
2. Direct access key for currents (instantaneous and max. values), current THD and test function.
3. Direct access key for voltages, frequency and voltage THD.
4. Pushbutton for active, reactive, and apparent power (instantaneous and max. values) and power factor.
5. Direct access key for energies, hour meter and programming menu.

Case

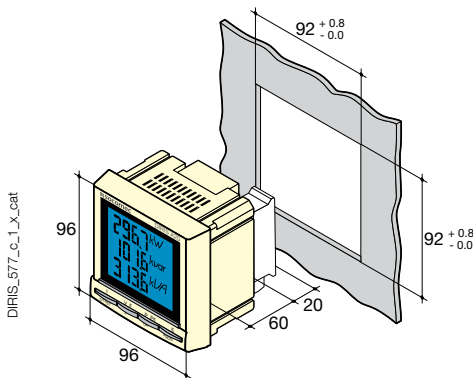

Type	panel mounting
Dimensions W x H x D	96 x 96 x 60 mm
Case degree of protection	IP30
Front degree of protection	IP52
Display type	backlit LCD display
Terminal block type	Fixed or plug-in
Voltage and other connection cross-section	0.2 ... 2.5 mm ²
Current connection cross-section	0.5 ... 6 mm ²
Weight	400 g

Plug-in modules

DIRIS® A20



1 Output

- 1 output assignable to:
- Pulses: configurable (type, weight, duration) in kWh or kvarh.
 - Monitoring: 3I, In, 3V, 3U, F, ΣP, ΣQ, ΣS, ΣPFL/C, THD 3I, THD 3V, THD 3U and timer.
 - Remote command of device.



Communication

RS485 link with JBUS / MODBUS protocol (speed up to 38400 bauds)



3 inputs, 1 output

- 3 inputs assignable to:
- Remote status device.
- 1 output assignable to:
- Pulses: configurable (type, weight, duration) in kWh or kvarh.
 - Monitoring: 3I, In, 3V, 3U, F, ΣP, ΣQ, ΣS, ΣPFL/C, THD 3I, THD 3V, THD 3U and timer.
 - Remote command of device.

Accessories

Current transformers (see page 78)

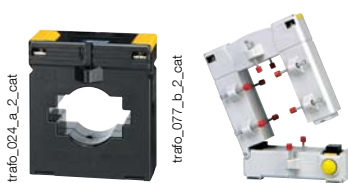

IP65 protection



Panel mounting kit for a 144 x 96 mm cut-out



DIRIS A20

Multifunction meters - PMD

Multi-measurement meter - dimensions 96 x 96 mm

Electrical characteristics

Current measurement (TRMS)	
Via CT primary	9 999 A
Via CT secondary	5 A
Measurement range	0 ... 11 kA
Input consumption	0.6 VA
Measurement updating period	1 s
Accuracy	0.2 %
Permanent overload	6 A
Intermittent overload	10 I _n for 1 s
Voltage measurements (TRMS)	
Direct measurement between phases	50 ... 500 VAC
Direct measurement between phase and neutral	28 ... 289 VAC
Input consumption	≤ 0.1 VA
Measurement updating period	1 s
Accuracy	0.2 %
Permanent overload	800 VAC
Power measurement	
Measurement updating period	1 s
Accuracy	0.5 %
Power factor measurement	
Measurement updating period	1 s
Accuracy	0.5 %
Frequency measurement	
Measurement range	45 ... 65 Hz
Measurement updating period	1 s
Accuracy	0.1 %

Energy accuracy	
Active (according to IEC 62053-22)	Class 0.5 S
Reactive (according to IEC 62053-23)	Class 2
Auxiliary power supply	
Alternating voltage	110 ... 400 VAC
AC tolerance	± 10 %
Direct voltage	120 ... 350 VDC
DC tolerance	± 20 %
Frequency	50 / 60 Hz
Consumption	10 VA
Pulse or alarm output	
Number	1
Type	100 VDC - 0.5 A - 10 VA
Max. number of operations	≤ 10 ⁸
Inputs	
Number	3
Power supply	10 ... 30 VDC
Minimum signal width	10 ms
Minimum duration between 2 pulses	18 ms
Type	Phototransistors
Communication	
Link	RS485
Type	2 ... 3 half duplex wires
Protocol	MODBUS RTU
MODBUS® speed	1400 ... 38400 bauds
Operating conditions	
Operating temperature	- 10 ... + 55 °C
Storage temperature	- 20 ... + 85 °C
Relative humidity	95 %

Terminals

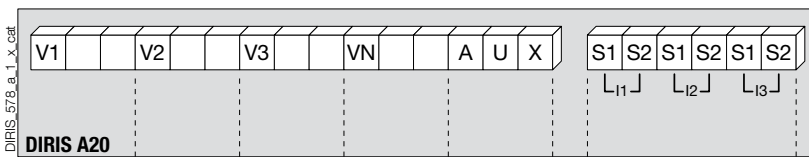

S1 - S2: current inputs.

AUX: auxiliary power supply U_s.
V1, V2, V3 & VN: voltage inputs.

Communication module

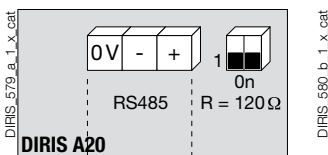

RS485 link.

R = 120 Ω: selectable internal resistance for RS485 end of line termination.

Output or alarm module

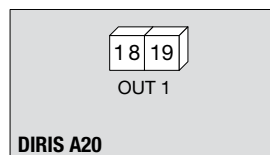

18 - 19: output n°1

3 inputs, 1 output module

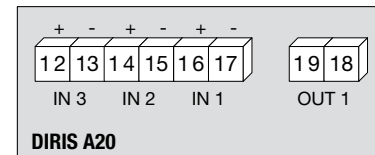

Connection

Recommendation:

- For IT earthing systems, it is recommended that the CT secondary is not connected to earth.
- When disconnecting the DIRIS, the secondary of each current transformer must be short-circuited. This operation can be carried out automatically by a SOCOMEC PTI, an accessory which is included in this catalogue. Please consult us.

Low voltage balanced network

3/4 wires with 1 CT

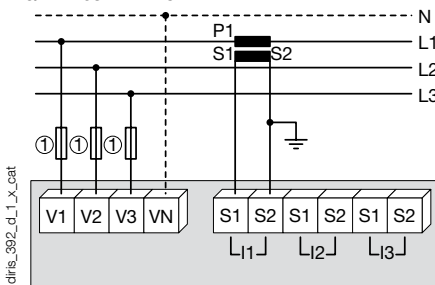

Use of 1 CT reduces by 0.5% the accuracy of the phases, the current of which is worked out by vector calculation.
1. Fuses 0.5 A gG / 0.5 A class CC.

Single-phase

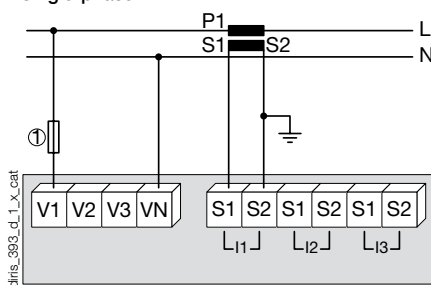

1. Fuses 0.5 A gG / 0.5 A class CC.

Two-phase

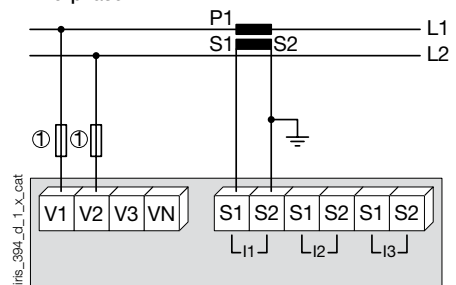

1. Fuses 0.5 A gG / 0.5 A class CC.

Low voltage unbalanced network

3/4 wires with 3 CTs

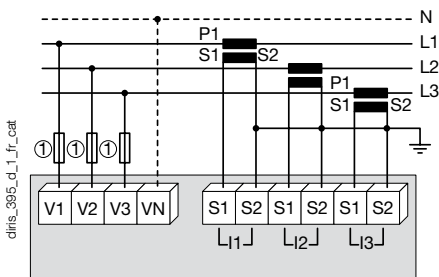

1. Fuses 0.5 A gG / 0.5 A class CC.

3 wires with 2 CTs

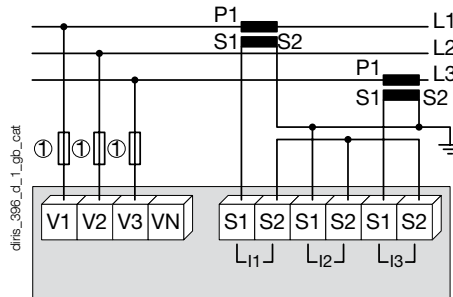

Use of 2 CTs reduces by 0.5% the accuracy of the phases, the current of which is worked out by vector calculation.

1. Fuses 0.5 A gG / 0.5 A class CC.

3 wires with 2 CTs

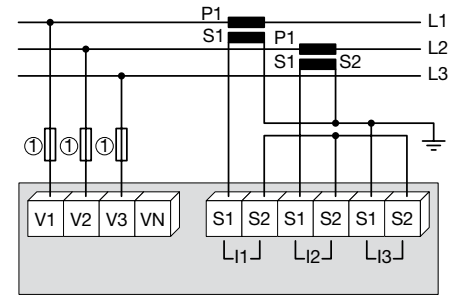

Use of 2 CTs reduces by 0.5% the accuracy of the phases, the current of which is worked out by vector calculation.

1. Fuses 0.5 A gG / 0.5 A class CC.

Additional information

Communication via RS485 link

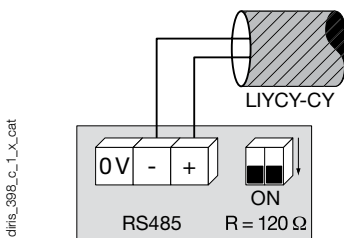

diris_398_c_1_x_cat

AC & DC auxiliary power supply

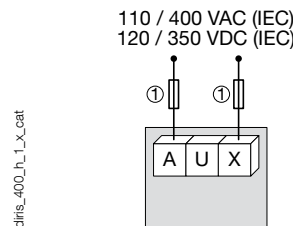

diris_400_h_1_x_cat

1. Fuses 0.5 A gG / 0.5 A class CC.

References

Basic device		DIRIS A20
Auxiliary power supply U_s		Reference
110 ... 400 VAC / 120 ... 350 VDC		4825 0200
Optional plug-in modules		Reference
1 output		4825 0080
RS485 MODBUS® communication		4825 0082
3 inputs, 1 output		4825 0083
Accessories		
Description of accessories	To be ordered in multiples of	Reference
IP65 protection	1	4825 0089
Panel mounting kit for a 144 x 96 mm cut-out	1	4825 0088
Fuse disconnect switches for the protection of voltage inputs (type RM) 3 poles	4	5601 0018
Fuse disconnect switches for the protection of the auxiliary supply (type RM) 1 pole + neutral	6	5601 0017
Fuse type gG 10x38 0.5 A	10	6012 0000
Ferrite to be associated with communication modules	1	4899 0011
Current transformer range	1	See page 98
Management software for DIRIS		See page 142

Services & Technical Assistance

> Technical site audits and solution specification, commissioning, maintenance, training... Our Services & Technical Assistance experts offer you personalised support to ensure success with all your projects.





DIRIS A40/A41

Multifunction meters - PMD

Multi-measurement meter - dimensions 96 x 96 mm

Single-circuit metering,
measurement &
analysis



DIRIS A41

The solution for

- > Industry
- > Data centres
- > Infrastructures



Strong points

- > Easy to use
- > Detects wiring errors
- > Customisable
- > Webserver function
- > Compliant with IEC 61557-12

Conformity to standards

- > IEC 61557-12
- > IEC 62053-22 class 0.5S
- > IEC 62053-23 class 2



Function

DIRIS A40 and A41 are panel mounted measurement units which ensure the user has access to all the measurements required for successfully carrying out energy efficiency projects and ensuring the electrical distribution is monitored.

All this information can be analysed remotely using the VERTELIS software solution.

The DIRIS A41 has a CT current input for measuring the neutral current.

Advantages

Easy to use

Thanks to its large backlit LCD display and its multiple viewing screens with direct pushbutton access, DIRIS A4x provide clear readings and are easy to use.

They directly display a number of multi-measurement and metering values : +/- kWh, +/- kvarh, kVAh, I, U, V, F, P, Q, S, PF, etc.

Detects wiring errors

An integrated test function can be utilised to detect incorrect wiring and to automatically correct CT installation errors.

Customisable

Thanks to the wide range of optional modules, the product can be customised or upgraded after installation.

Principle diagram

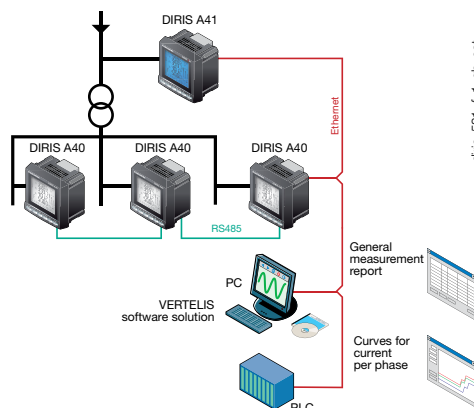

diris_581_t_1_gb_cat

Webserver function

Optional Ethernet communication modules include a Webserver function for monitoring and exploiting data remotely without additional software.

Compliant with IEC 61557-12

IEC 61557-12 is a high-level standard for all PMDs (Performance Monitoring Devices) that are designed to measure and monitor electrical parameters in distribution networks.

Compliance with IEC 61557-12 ensures a high level of equipment performance, in terms of metrology, and the mechanical and environmental aspects (EMC, temperature, etc.).

Functions

Multi-measurement

- Currents
 - instantaneous: I1, I2, I3, In, Isystem
 - average/maximum average: I1, I2, I3, In
- Voltages & frequency
 - instantaneous: V1, V2, V3, U12, U23, U31, F, Vsystem, Ussystem
 - average/maximum average: V1, V2, V3, U12, U23, U31, F
- Power
 - instantaneous: 3P, ΣP , 3Q, ΣQ , 3S, ΣS
 - maximum average: ΣP , ΣQ , ΣS
 - predictive: (ΣP), (ΣQ), (ΣS)
- Power factors
 - instantaneous: 3PF, ΣPF
 - average/maximum average: ΣPF

- Temperatures⁽¹⁾
 - internal
 - external via 3 PT100 sensors

Metering

- Active energy: +/- kWh
- Reactive energy: +/- kvarh
- Apparent power: kVAh
- Hours: ⌚

Harmonic analysis

- Total harmonic distortion
 - Currents: thd I1, thd I2, thd I3, thd In
 - Phase-to-neutral voltage: thd V1, thd V2, thd V3
 - Phase-to-phase voltage: thd U12, thd U23, thd U31

- Individual up to level 63
 - Currents: HI1, HI2, HI3, HIn
 - Phase-to-neutral voltage: HV1, HV2, HV3,
 - Phase-to-phase voltage: HU12, HU23, HU31

Load curves⁽¹⁾

- Active and reactive power: ΣP +/- ; ΣQ +/-
- Voltages & frequency: V1, V2, V3, U12, U23, U31, F

Events⁽¹⁾

- Alarms on all electrical values.

Communications⁽¹⁾

- RS485 MODBUS RTU & PROFIBUS DP
- Ethernet (MODBUS TCP or RTU over TCP and Web server)
- Ethernet with RS485 gateway MODBUS RTU over TCP

Inputs / Outputs⁽¹⁾

- Pulse metering
- Remote control/command
- Alarm report
- Pulse report

Analogue output

- 0/4- 20 mA analogue output

⁽¹⁾ Available as an option
(see the following pages).

Front panel



1. Backlit LCD display.
2. Direct access key for currents and test function.
3. Direct access key for voltages and frequency.
4. Direct access key for active, reactive, and apparent powers and power factor.
5. Direct access key for maximum and average current and power values.
6. Direct access key for harmonic values.
7. Direct access key for energies, hour meter and programming menu.

Plug-in modules

DIRIS® A40











diris_773_a

DIRIS® A41*



diris_774_a

* with a factory fitted neutral CT module.

	<p>Pulse outputs</p> <p>2 configurable pulse outputs (type, weight and duration) on \pm kWh, \pm kvarh and kVAh.</p>
	<p>Communication MODBUS®</p> <p>RS485 link with MODBUS® protocol (speed up to 38400 bauds).</p>
	<p>PROFIBUS® DP communication</p> <p>SUB-D9 link with PROFIBUS® DP protocol (speed up to 12 Mbauds).</p>
	<p>Ethernet communication</p> <ul style="list-style-type: none"> • Ethernet connection with MODBUS TCP or MODBUS RTU over TCP protocol. • Embedded Webserver function⁽¹⁾.
	<p>Ethernet communication with RS485 MODBUS gateway</p> <ul style="list-style-type: none"> • Ethernet connection with MODBUS TCP or MODBUS RTU over TCP protocol. • Connection of 1 to 247 RS485 MODBUS slaves. • Embedded Webserver function⁽¹⁾.
	<p>Analogue outputs</p> <p>A maximum of 2 modules may be connected, providing up to 4 analogue outputs. Per module 2 outputs assignable to:</p> <p>3I, In, 3V, 3U, F, \pm ΣP, \pm ΣQ, ΣS, ΣPFL/C, I sys, Vsys, Usys, Ppred, Q pred, Spred, T°C internal, T°C 1, T°C 2, T°C3 and to 17 VDC power supply.</p>
	<p>2 inputs - 2 outputs</p> <p>A maximum of 3 modules may be connected, providing up to 6 inputs and 6 outputs. Per module 2 outputs assignable to:</p> <ul style="list-style-type: none"> - monitoring: 3I, In, 3V, 3U, F, \pm ΣP, \pm ΣQ, ΣS, ΣPFL/C, THD 3I, THD In, THD 3V, THD 3U, Ppred, Qpred, Spred, internal T°C, T°C 1, T°C2, T°C3 and hour meter, - remote control, - timed remote control. - 2 inputs for pulse metering.
	<p>Memory</p> <ul style="list-style-type: none"> • Storing up to a maximum of 62 days of P+, P-, Q+, Q- with an internal or external synchronisation signal of 5, 8, 10, 15, 20, 30 and 60 minutes. • Storing of 10 hour-dated last alarms. • Storing of the last minimum and maximum instantaneous values for 3U, 3V, 3I, In, F, ΣP\pm, ΣQ\pm, ΣS, THD 3U, THD 3V, THD, 3U, THD, 3V, THD, 3I, THD In. • Storing of 3U, 3V and F average values based on synchronisation function (maximum 60 days).
	<p>Temperature⁽²⁾</p> <p>Temperature indication:</p> <ul style="list-style-type: none"> - internal, - external sensor PT 100 (T°C 1), - external sensor PT 100 (T°C 2), - external sensor PT 100 (T°C 3).

(1) See "Management software for DIRIS" p. 142.
 (2) See "external sensor PT 100" p. 115.

DIRIS A40/A41

Multifunction meters - PMD

Multi-measurement meter - dimensions 96 x 96 mm

Accessories

Current transformers
(see page 98)

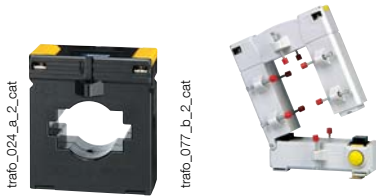

IP65 protection



Panel mounting kit for a 144 x 96 mm cut-out



Terminals

DIRIS A40

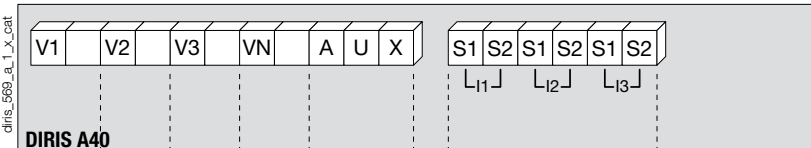

S1 - S2: current inputs

AUX: auxiliary power supplies U_s
V1 - V2 - V3 - VN: voltage inputs

DIRIS A41

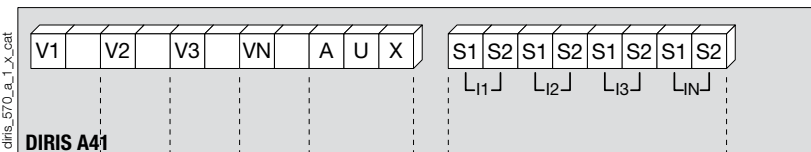

S1 - S2: current inputs

AUX: auxiliary power supplies U_s
V1 - V2 - V3 - VN: voltage inputs

Communication module

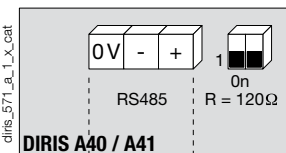

RS485 link.
R = 120 Ω : selectable internal resistance for RS485 end of line termination.

Pulse output module

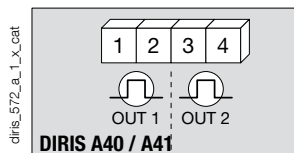

1 - 2: pulse output n°1.
3 - 4: pulse output n°2.

Analogue output module

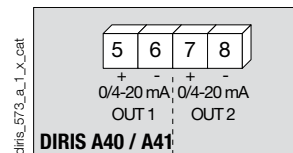

5 - 6: analogue output n°1.
7 - 8: analogue output n°2.

2 inputs / 2 outputs module

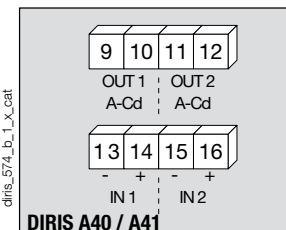

9 - 10: relay output n°1.
11 - 12: relay output n°2.
13 - 14: opto input n°1.
15 - 16: opto input n°2.

Memory module

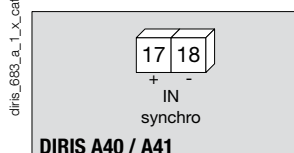

17 - 18: synchronisation input.

Temperature module

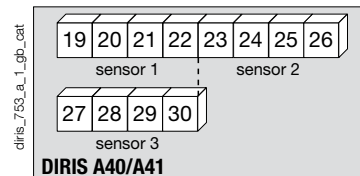

Sensor 1 Sensor 2 Sensor 3
19: red 23: red 27: red
20: red 24: red 28: red
21: white 25: white 29: white
22: white 26: white 30: white

Ethernet Module

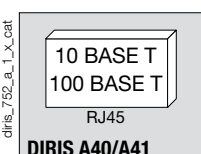

Ethernet module + RS485 MODBUS gateway

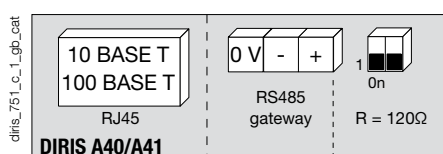

Electrical characteristics

Current measurement on insulated inputs (TRMS)	
Via CT primary	9 999 A
Via CT secondary	1 or 5 A
Measurement range	0 ... 11 kA
Input consumption	≤ 0.1 VA
Measurement updating period	1 s
Accuracy	0.2 %
Permanent overload	6 A
Intermittent overload	10 I _n for 1 s
Voltage measurements (TRMS)	
Direct measurement between phases	50 ... 700 VAC
Direct measurement between phase and neutral	28 ... 404 VAC
VT primary	500 000 VAC
VT secondary	60, 100, 110, 173, 190 VAC
Frequency	50 / 60 Hz
Input consumption	≤ 0.1 VA
Measurement updating period	1 s
Accuracy	0.2 %
Permanent overload	800 VAC
Current-voltage product	
Limitation for 1A CT	10 000 000
Limitation for 5A CT	10 000 000
Power measurement	
Measurement updating period	1 s
Accuracy	0.5 %
Power factor measurement	
Measurement updating period	1 s
Accuracy	0.5 %
Frequency measurement	
Measurement range	45 ... 65 Hz
Measurement updating period	1 s
Accuracy	0.1 %
Energy accuracy	
Active (according to IEC 62053-22)	Class 0.5 S
Reactive (according to IEC 62053-23)	Class 2
Auxiliary power supply	
Alternating voltage	110 ... 400 VAC
AC tolerance	± 10 %
Direct voltage	120 ... 350 VDC / 12 ... 48 VDC
DC tolerance	± 20 % / - 6 ... + 20 %
Frequency	50 / 60 Hz
Consumption	≤ 10 VA

2 inputs / 2 outputs module: Outputs (alarms / control)	
Number of relays	2 ⁽¹⁾
Type	250 VAC - 5 A - 1150 VA
2 inputs / 2 outputs module: Phototransistor inputs	
Number	2 ⁽¹⁾
Power supply	10 ... 30 VDC
Minimum signal width	10 ms
Minimum duration between 2 pulses	18 ms
Type	phototransistors
Pulse output module	
Number of relays	2
Type	100 VDC - 0.5 A - 10 VA
Max. number of operations	≤ 10 ⁸
Analogue output module	
Number of outputs	2 ⁽²⁾
Type	insulated
Range	0 / 4 ... 20 mA
Load resistance	600 Ω
Maximum current	30 mA
MODBUS communication module	
Link	RS485
Type	2 ... 3 half duplex wires
Protocol	MODBUS RTU
MODBUS [®] speed	4800 ... 38400 bauds
PROFIBUS-DP communication module	
Link	SUB-D9
Protocol	PROFIBUS [®] DP
PROFIBUS [®] speed	9.8 kbauds ... 12 Mbauds
Ethernet communication module	
Connection	RJ45
Speed	10 base T / 100 base T
Protocol	MODBUS TCP or MODBUS RTU over TCP
Temperature module (inputs)	
Type	PT100
Connection	2, 3 or 4 wires
Dynamic	- 20 °C ... 150 °C
Accuracy	+/- 1 digit
Maximum length	300 cm
Operating conditions	
Operating temperature	- 10 ... + 55 °C
Storage temperature	- 20 ... + 85 °C
Relative humidity	95 %

(1) Max. 3 modules / DIRIS.

(2) Max. 2 modules / DIRIS.

Case

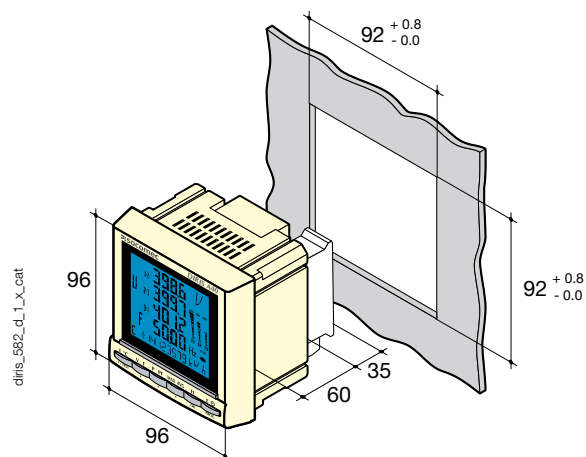

Type	panel mounting
Dimensions W x H x D	96 x 96 x 60 mm
Case degree of protection	IP30
Front degree of protection	IP52
Display type	backlit LCD display
Terminal blocks type	fixed or plug-in
Voltage and other connection cross-section	0.2 ... 2.5 mm ²
Current connection cross-section	0.5 ... 6 mm ²
Weight	400 g

DIRIS A40/A41

Multifunction meters - PMD

Multi-measurement meter - dimensions 96 x 96 mm

Connections

Recommendation: When disconnecting the DIRIS, the secondary of each current transformer must be short-circuited. This operation can be carried out automatically by a SOCOMEC PTI, an accessory which is included in this catalogue. Please consult us. In TNC neutral systems it is recommended to use the functional earth module.

Low voltage balanced network for DIRIS A40

3/4 wires with 1 CT

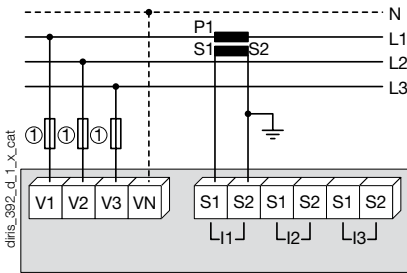

Use of 1 CT reduces by 0.5% the accuracy of the phases, the current of which is worked out by vector calculation.

1. Fuses 0.5 A gG / 0.5 A class CC.

Single-phase

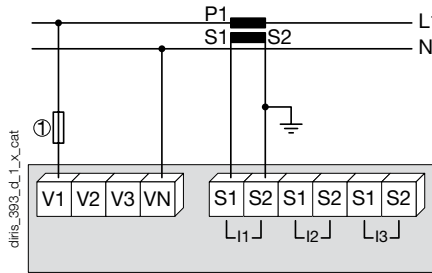

1. Fuses 0.5 A gG / 0.5 A class CC.

Two-phase

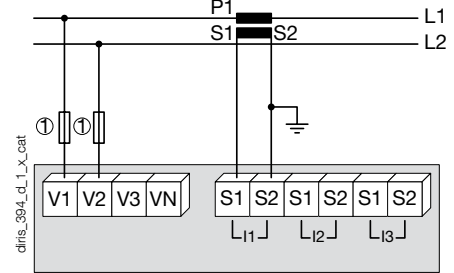

1. Fuses 0.5 A gG / 0.5 A class CC.

Low voltage unbalanced network for DIRIS A40

3/4 wires with 3 CTs

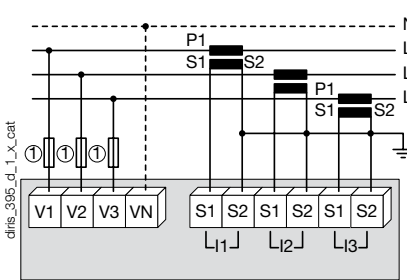

1. Fuses 0.5 A gG / 0.5 A class CC.

3 wires with 2 CTs

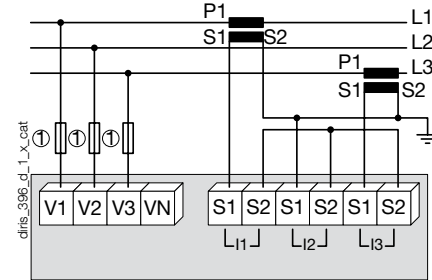

Use of 2 CTs reduces by 0.5% the accuracy of the phases, the current of which is worked out by vector calculation.

1. Fuses 0.5 A gG / 0.5 A class CC.

3 wires with 2 CTs

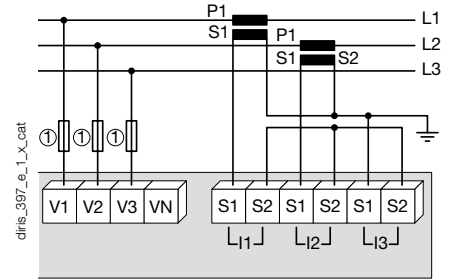

Use of 2 CTs reduces by 0.5% the accuracy of the phases, the current of which is worked out by vector calculation.

1. Fuses 0.5 A gG / 0.5 A class CC.

Low voltage unbalanced network for DIRIS A41

4 wires with 4 CTs

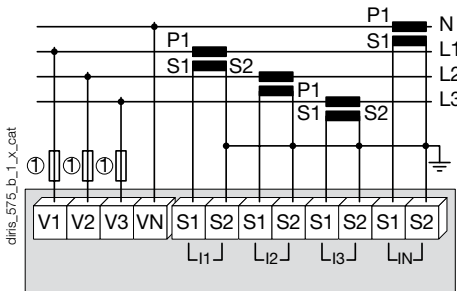

1. Fuses 0.5 A gG / 0.5 A class CC.

Additional information

Communication via RS485 link

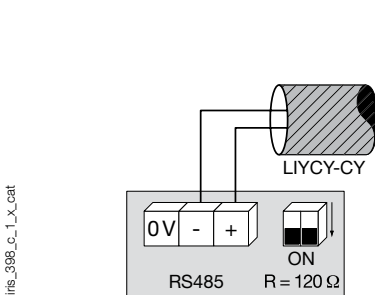

Connection of voltage transformer for HV networks

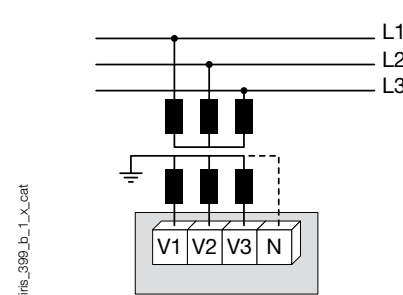

AC & DC auxiliary power supply

110 / 400 VAC (IEC)
120 / 350 VDC (IEC)

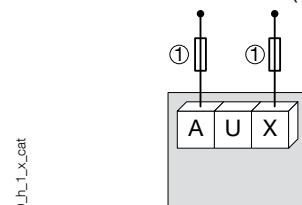

1. Fuses 0.5 A gG / 0.5 A class CC.

References

Basic device	DIRIS A40		DIRIS A41 with CT on the neutral
Auxiliary power supply U_s	Reference		Reference
110 ... 400 VAC / 120 ... 350 VDC	4825 0201		4825 0202
12 ... 48 VDC	4825 1201		4825 1202
Options			
Plug-in modules⁽¹⁾	Reference		Reference
Pulse outputs	4825 0090		4825 0090
RS485 MODBUS [®] communication	4825 0092		4825 0092
Analogue outputs	4825 0093		4825 0093
2 inputs / 2 outputs	4825 0094		4825 0094
Communication Sub D9 PROFIBUS [®] DP ⁽²⁾	4825 0205		4825 0205
Memory	4825 0097		4825 0097
Embedded Webserver function ⁽²⁾ .	4825 0203		4825 0203
Ethernet communication + RS485 MODBUS gateway (Embedded Webserver function) ⁽²⁾	4825 0204		4825 0204
Temperature inputs	4825 0206		4825 0206

(1) Ease of integration for additional functions (maximum 4 slots on A40 and 3 on A41).

(2) Dimension of the plug-in module: 2 slots.

Accessories				
Description of accessories	To be ordered in multiples of	Reference	To be ordered in multiples of	Reference
IP65 protection	1	4825 0089	1	4825 0089
Panel mounting kit for a 144 x 96 mm cut-out	1	4825 0088	1	4825 0088
Fuse disconnect switches for the protection of voltage inputs (type RM) 3 poles	4	5601 0018	4	5601 0018
Fuse disconnect switches for the protection of the auxiliary supply (type RM) 1 pole + neutral	6	5601 0017	6	5601 0017
Fuse type gG 10x38 0.5 A	10	6012 0000	10	6012 0000
Current transformer range	1	See page	1	See page 98
Ferrite to be associated with communication modules	1	4899 0011		4899 0011
Temperature sensor PT100 - M6 screw type	1	4825 0208	1	4825 0208
Temperature sensor PT100 - M6 eyelet type	1	4825 0209	1	4825 0209
Management software for DIRIS				See page 142

Services & Technical Assistance

- Technical site audits and solution specification, commissioning, maintenance, training... Our Services & Technical Assistance experts offer you personalised support to ensure success with all your projects.





DIRIS A60

Multifunction meters - PMD

Energy monitoring and event analysis - dimensions 96x96 mm

Single-circuit metering,
measurement &
analysis



DIRIS A60

Principle diagram

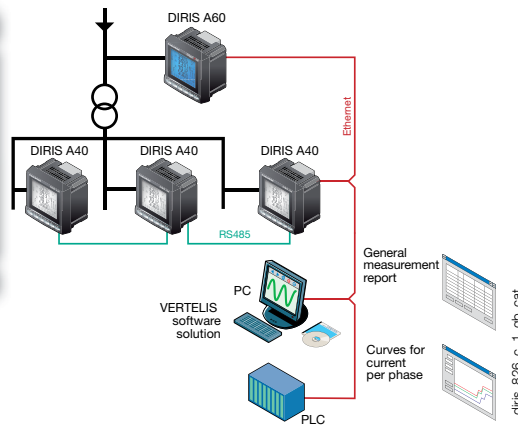

The solution for

- > Industry
- > Infrastructure
- > Data centres



Strong points

- > Easy to use
- > Detects wiring errors
- > Compliant with IEC 61557-12
- > Management softwares
- > Conformity to standard EN 50160

Conformity to standards

- > IEC 61557-12
- > IEC 62053-22 class 0.5S
- > IEC 62053-23 class 2
- > EN 50160



Function

DIRIS A60 is a panel mounted multifunction meter which incorporates all functions of the DIRIS A40 with the addition of enhanced data logging functions, recording curves for quality events. All this information can be analysed remotely using the Analysis software which is available at no charge and can be downloaded from the SOCOMEC website www.socomec.com.

Advantages

Easy to use

Thanks to its large backlit LCD display and its multiple viewing screens with direct key access, the DIRIS A60 provides clear readings and is easy to use.

It directly displays a number of multi-measurement and metering values : +/- kWh, +/- kvarh, kVAh, I, U, V, F, P, Q, S, PF, etc.

Detects wiring errors

An integrated test function can be utilised to detect incorrect wiring and to automatically correct CT installation errors.

Compliant with IEC 61557-12

IEC 61557-12 is a high-level standard for all PMDs (Performance Monitoring Devices) that are designed to measure and monitor electrical parameters in distribution networks.

Compliance with IEC 61557-12 ensures a high level of equipment performance, in terms of metrology, and the mechanical and environmental aspects (EMC, temperature, etc.).

Management softwares

- Optional Ethernet module with Webserver function: For measurement monitoring, data exploitation and the export of load curves remotely without a specific software (web browser access).
- Analysis software: For the analysis of events data in order to improve the reliability of the electrical installation.
- Easy Config software: For quick and easy remote device configuration; configuration files can be copied from and sent to the DIRIS A60, or they can be created without communication and sent at a later time. Multiple devices can be configured from a single file, which is especially useful for OEMs and panel builders.

Conformity to standard EN 50160

EN 50160 is a standard which defines events relating to the quality of electrical networks. The DIRIS A60 captures voltage events in accordance with this standard.

Functions

In addition to the functions of the DIRIS A40, the DIRIS A60 also:

- shows the current and voltage unbalance
- shows the tangent φ
- stores the load curves (60 days with an interval of 10 minutes) for the active, reactive and apparent power: ΣP +/-; ΣQ +/-; ΣS
- detects and stores the last 40 events concerning:
 - overvoltage
 - voltage dips
 - cut-offs
 - overcurrent.

For each stored event, the DIRIS A60 records the relevant RMS 10 ms interval curves for the voltages V1, V2, V3, U12, U23, U31 and the currents I1, I2, I3, In, giving a total of 400 curves.

Other functions:

Multi-measurement

Currents

- instantaneous: I1, I2, I3, In, Isystem,
- average/maximum average: I1, I2, I3, In,
- unbalance: I unb.
- Voltages & frequency
 - instantaneous: V1, V2, V3, U12, U23, U31, F, Vsystem, Usystem
 - average/maximum average: V1, V2, V3, U12, U23, U31, F
 - unbalance: U unb.
- Power
 - instantaneous: 3P, ΣP , 3Q, ΣQ , 3S, ΣS
 - maximum average: ΣP , ΣQ , ΣS
 - predictive: ΣP , ΣQ , ΣS .
- Power factor - PF, ΣPF
- Instantaneous total tangent φ
- Instantaneous, average and max. average unbalance

- Temperatures⁽¹⁾
 - internal,
 - external via 3 PT100 sensors

Metering

- Active energy: +/- kWh
- Reactive energy: +/- kvarh
- Apparent power: kVAh
- Hours: \odot

Harmonic analysis (level 63)

- Total harmonic distortion
 - Currents: thd I1, thd I2, thd I3, thd In
 - Phase-to-neutral voltage: thd V1, thd V2, thd V3
 - Phase-to-phase voltage: thd U12, thd U23, thd U31
- Individual
 - Currents: HI1, HI2, HI3, HIn
 - Phase-to-neutral voltage: HV1, HV2, HV3,
 - Phase to phase voltage: HU12, HU23, HU31

Events⁽¹⁾

- Alarms on all electrical values

Communications⁽¹⁾

- 0/4- 20 mA analogue output
- RS485 MODBUS RTU
- Ethernet (MODBUS TCP or MODBUS RTU over TCP and Webserver)
- Ethernet (MODBUS TCP or MODBUS RTU over TCP and Webserver) with RS485 MODBUS RTU gateway
- Inputs / Outputs⁽¹⁾
 - Pulse metering
 - Remote control/command
 - Alarm report
 - Pulse report

⁽¹⁾ Available as an option (see the following pages).

Front panel



1. Backlit LCD display.
2. Direct access key for currents, temperatures and test function.
3. Direct access key for voltages and frequency.
4. Direct access key for active, reactive, and apparent powers and power factor.
5. Direct access key for maximum and average current, voltage and power values.
6. Direct access key for harmonics values.
7. Direct access key for energies, hour meter and programming menu.

Plug-in modules

DIRIS® A60*



* With integrated memory module.



Pulse outputs

- 2 configurable pulse outputs (type, weight and duration) on \pm kWh, \pm kvarh and kVAh.



Communication MODBUS®

- RS485 link with MODBUS® protocol (speed up to 38400 bauds).



Ethernet communication

- Ethernet connection with MODBUS TCP or MODBUS RTU over TCP protocol.
- Embedded Webserver function⁽¹⁾.



Ethernet communication with RS485 MODBUS gateway

- Ethernet connection with MODBUS TCP or MODBUS RTU over TCP protocol.
- Connection of 1 to 247 RS485 MODBUS slaves.
- Embedded Webserver function⁽¹⁾.



Analogue outputs

- A maximum of 2 modules may be connected, providing up to 4 analogue outputs.
- Per module 2 outputs assignable to: 3I, In, 3V, 3U, F, \pm Σ P, \pm Σ Q, Σ S, Σ PFL/C, Isys, Vsys, Usys, Ppred, Q pred, Spred, T°C internal, T°C 1, T°C 2, T°C3 and to 17 VDC power supply.



2 inputs - 2 outputs

- A maximum of 3 modules may be connected, providing up to 6 inputs and 6 outputs.
- Per module 2 outputs assignable to:
 - monitoring: 3I, In, 3V, 3U, F, \pm Σ P, \pm Σ Q, Σ S, Σ PFL/C, THD 3I, THD In, THD 3V, THD 3U, Ppred, Qpred, Spred, T°C internal, T°C 1, T°C2, T°C3 and hour meter,
 - remote control,
 - timed remote control,
- 2 inputs for pulse metering.



Temperature⁽²⁾

- Temperature indication:
- Internal
 - External sensor PT 100 (T°C 1)
 - External sensor PT 100 (T°C 2)
 - External sensor PT 100 (T°C 3).

(1) See "Management softwares for DIRIS" p. 142.

(2) See "External sensor PT 100" p. 114.

DIRIS A60

Multifunction meters - PMD

Energy monitoring and event analysis - dimensions 96x96 mm

Accessories

Current transformers
(see page 98)



Split-core current transformers



IP65 protection



Panel mounting kit
for a 144 x 96 mm cut-out



Terminals

DIRIS A60

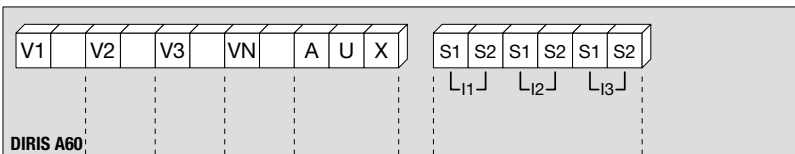

S1 - S2: current inputs

AUX: auxiliary power supplies U_s

V1 - V2 - V3 - VN: voltage inputs

RS485 MODBUS module

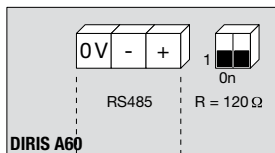

RS485 link.

R = 120 Ω : selectable internal resistance for RS485 end of line termination.

Ethernet module

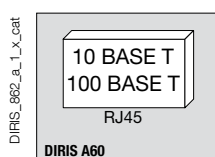

Ethernet module + RS485 MODBUS gateway

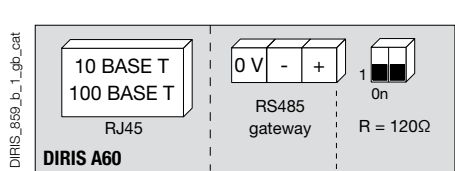

RS485 gateway resistor.

R = 120 Ω : selectable internal resistance for RS485 end of line termination.

Pulse output module

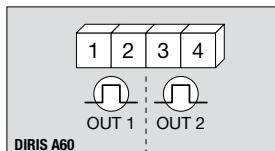

1 - 2: pulse output n°1.

3 - 4: pulse output n°2.

Temperature module

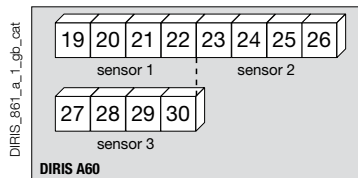

2 inputs / 2 outputs module

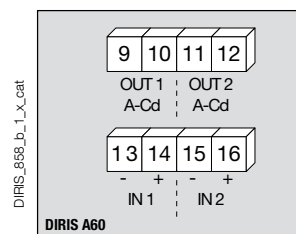

9 - 10: relay output n°1.

11 - 12: relay output n°2.

13 - 14: opto input n°1.

15 - 16: opto input n°2.

Analogue output module

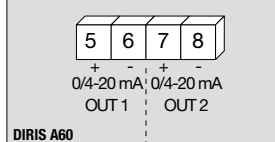

5 - 6: analogue output n°1.

7 - 8: analogue output n°2.

Electrical characteristics

Current measurement on insulated inputs (TRMS)	
Via CT primary	9 999 A
Via CT secondary	1 or 5
Measurement range	0 ... 11 kA
Input consumption	≤ 0.1 VA
Measurement updating period	1 s
Accuracy	0.2 %
Permanent overload	6 A
Intermittent overload	10 I _n for 1 s
Voltage measurements (TRMS)	
Direct measurement between phases	50 ... 700 VAC
Direct measurement between phase and neutral	28 ... 404 VAC
VT primary	500 000 VAC
VT secondary	60, 100, 110, 173, 190 VAC
Frequency	50 / 60 Hz
Input consumption	≤ 0.1 VA
Measurement updating period	1 s
Accuracy	0.2 %
Permanent overload	800 VAC
Current-voltage product	
Limitation for 1A CT	10 000 000
Limitation for 5A CT	10 000 000
Power measurement	
Measurement updating period	1 s
Accuracy	0.5 %
Power factor measurement	
Measurement updating period	1 s
Accuracy	0.5 %
Frequency measurement	
Measurement range	45 ... 65 Hz
Measurement updating period	1 s
Accuracy	0.1 %
Energy accuracy	
Active (according to IEC 62053-22)	Class 0.5 S
Reactive (according to IEC 62053-23)	Class 2
Auxiliary power supply	
Alternating voltage	110 ... 400 VAC
AC tolerance	± 10 %
Direct voltage	120 ... 350 VDC
DC tolerance	± 20 %
Frequency	50 / 60 Hz
Consumption	≤ 10 VA

2 inputs / 2 outputs module: Outputs (alarms / control)	
Number of relays	2 ⁽¹⁾
Type	250 VAC - 5 A - 1150 VA
2 inputs / 2 outputs module: Phototransistor inputs (pulse metering)	
Number	2 ⁽¹⁾
Power supply	10 ... 30 VDC
Minimum signal width	10 ms
Minimum duration between 2 pulses	18 ms
Type	phototransistors
Pulse output module	
Number of relays	2
Type	100 VDC - 0.5 A - 10 VA
Max. number of operations	≤ 10 ⁸
Analogue output module	
Number of outputs	2 ⁽²⁾
Type	insulated
Range	0 / 4 ... 20 mA
Load resistance	600 Ω
Maximum current	30 mA
MODBUS communication module	
Link	RS485
Type	2 ... 3 half duplex wires
Protocol	MODBUS RTU
MODBUS [®] speed	4800 ... 38400 bauds
Ethernet communication module	
Connection	RJ45
Speed	10 base T / 100 base T
Protocol	MODBUS TCP or MODBUS RTU over TCP
Temperature inputs	
Type	PT100
Connection	2, 3 or 4 wires
Dynamic	- 20 °C ... 150 °C
Accuracy	+/- 1 digit
Maximum length	300 cm
Operating conditions	
Operating temperature	- 10 ... + 55 °C
Storage temperature	- 20 ... + 85 °C
Relative humidity	95 %

(1) Max. 3 modules / DIRIS.

(2) Max. 2 modules / DIRIS.

Case

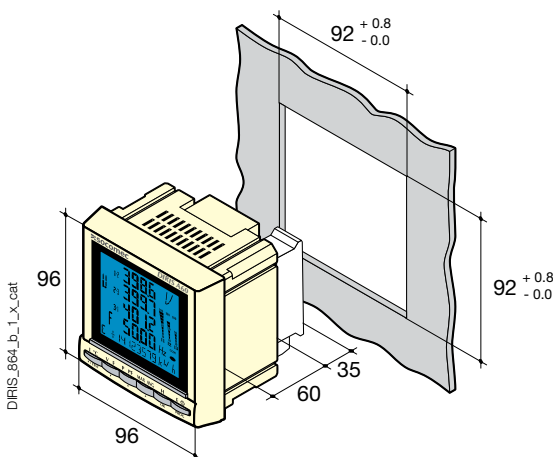

Type	panel mounting
Dimensions W x H x D	96 x 96 x 95 mm
Case degree of protection	IP30
Front degree of protection	IP52
Display type	backlit LCD display
Terminal blocks type	fixed or plug-in
Voltage and other terminals connection cross-section	0.2 ... 2.5 mm ²
Current connection cross-section	0.5 ... 6 mm ²
Weight	450 g

DIRIS A60

Multifunction meters - PMD

Energy monitoring and event analysis - dimensions 96x96 mm

Connection

Low voltage balanced network for DIRIS A60

Recommendation: When disconnecting the DIRIS, the secondary of each current transformer must be short-circuited. This operation can be carried out automatically by a SOCOMEC PTI, which can be found in the SOCOMEC catalogue: please consult us.

3/4 wires with 1 CT

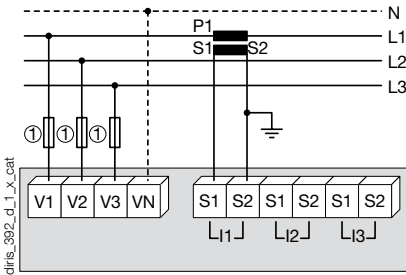

Use of 1 CT reduces by 0.5% the accuracy of the phases, the current of which is worked out by vector calculation.
1. Fuses 0.5 A gG / 0.5 A class CC.

Single-phase

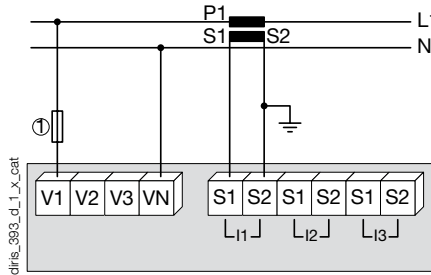

1. Fuses 0.5 A gG / 0.5 A class CC.

Two-phase

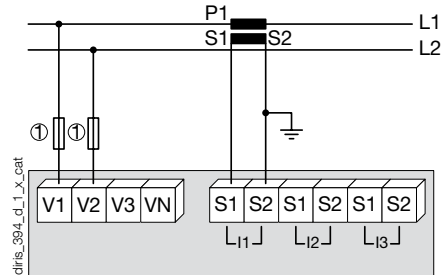

1. Fuses 0.5 A gG / 0.5 A class CC.

Low voltage unbalanced network for DIRIS A60

3/4 wires with 3 CTs

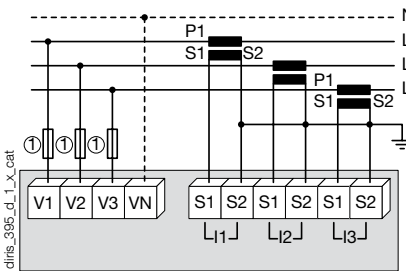

1. Fuses 0.5 A gG / 0.5 A class CC.

3 wires with 2 CTs

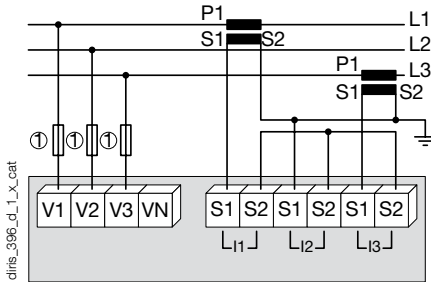

Use of 2 CTs reduces by 0.5% the accuracy of the phases, the current of which is worked out by vector calculation.
1. Fuses 0.5 A gG / 0.5 A class CC.

3 wires with 2 CTs

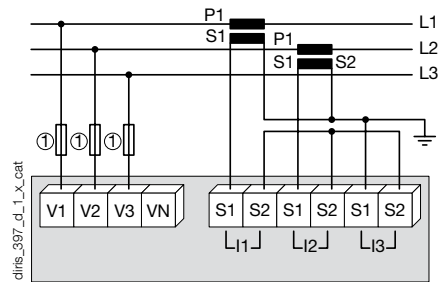

Use of 2 CTs reduces by 0.5% the accuracy of the phases, the current of which is worked out by vector calculation.
1. Fuses 0.5 A gG / 0.5 A class CC.

Additional information

Communication via RS485 link

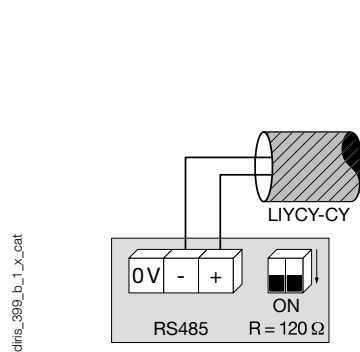

diris_399_b_1_x_cat

Connection of voltage transformer for HV networks

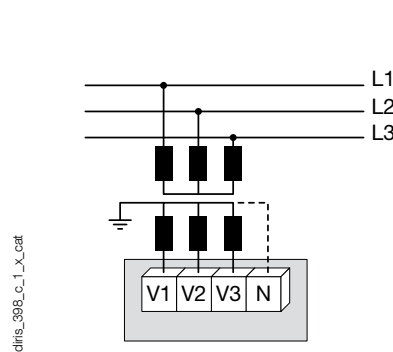

diris_398_c_1_x_cat

AC & DC auxiliary power supply

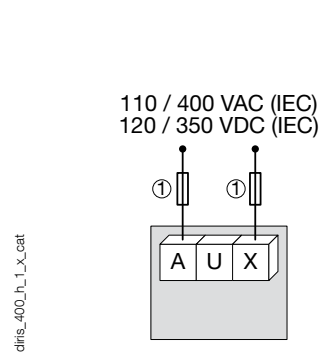

diris_400_h_1_x_cat

1. Fuses 0.5 A gG / 0.5 A class CC.

References

Basic device	DIRIS A60
Auxiliary power supply U_s	Reference
110 ... 400 VAC / 120 ... 350 VDC	4825 0207
Options	
Plug-in-modules⁽¹⁾	Reference
Pulse outputs	4825 0090
RS485 MODBUS [®] communication	4825 0092
Analogue outputs	4825 0093
2 inputs / 2 outputs	4825 0094
Ethernet communication (embedded Ethernet Webserver) ⁽²⁾	4825 0203
Ethernet communication + RS485 MODBUS gateway (embedded Ethernet Webserver) ⁽²⁾	4825 0204
Temperature inputs	4825 0206

(1) Easy integration of additional functions (maximum 3 slots per device).

(2) Dimension of the plug-in module: 2 slots.

Options	To be ordered in multiples of	Reference
Description of accessories		
IP65 protection	1	4825 0089
Panel mounting kit for a 144 x 96 mm cut-out	1	4825 0088
Fuse disconnect switches for the protection of voltage inputs (type RM) 3 poles	4	5601 0018
Fuse disconnect switches for the protection of the auxiliary supply (type RM) 1 pole + neutral	6	5601 0017
Fuse type gG 10x38 0.5 A	10	6012 0000
Ferrite to be associated with communication modules	1	4899 0011
Current transformer range	1	See page 98
Temperature sensor PT100 - M6 screw type	1	4825 0208
Temperature sensor PT100 - M6 eyelet type	1	4825 0209
Management softwares for DIRIS		See page 142

Services & Technical Assistance

- Technical site audits and solution specification, commissioning, maintenance, training... Our Services & Technical Assistance experts offer you personalised support to ensure success with all your projects.





DIRIS A80

Multifunction meters - PMD + RCM

Monitoring energy and fault currents - dimensions 96x96 mm

Single-circuit metering,
measurement &
analysis



DIRIS A80

Function

DIRIS A80 is a complete panel mounted multifunction meter which incorporates RCM current monitoring (Residual Current Monitoring), for networks with TN-S and TT neutral systems, and enhanced data logging functions for recording curves for quality and RCM events. The DIRIS A80 supplies all the measurements required for energy efficiency projects while its RCM function provides preventative earth leakage information, essential in critical applications to avoid installation shutdowns.

Advantages

Compact

The DIRIS A80 combines two complementary products within a single 96 x 96 mm panel mounted case, enabling faster installation and utilising less space. The DIRIS A80 comprises:

- a multifunction meter with enhanced event logging functions which records curves for quality events.
- an RCM fault current monitoring device (Residual Current Monitoring).

Conformity to standard EN 50160

- EN 50160 is a standard which defines events relating to the quality of electrical networks. The DIRIS A80 captures voltage events in accordance with this standard.

Principle diagram

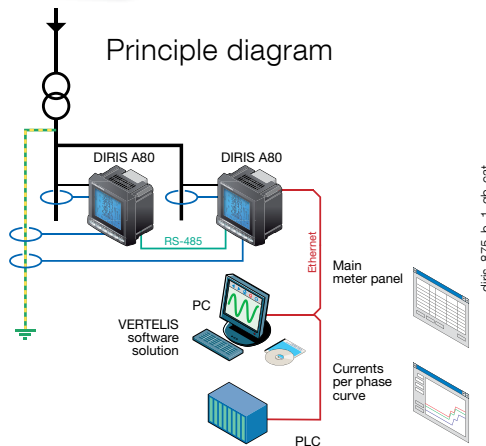

The solution for

- > Industry
- > Infrastructure
- > Health care buildings
- > Data centres

Strong points

- > Compact
- > Patented pending
- > Management softwares
- > Compliant with IEC 61557-12
- > Conformity to standard EN 50160

Conformity to standards

- > IEC 62053-22 class 0.5S
- > IEC 62053-23 class 2
- > IEC 61557-12
- > IEC 62020
- > EN 50160



Patent pending

Automatic adjustment of the leakage current alarm threshold in accordance with the load current to avoid false alarms.

Compliant with IEC 61557-12.

IEC 61557-12 is a high-level standard for all PMDs (Performance Monitoring Devices) that are designed to measure and monitor electrical parameters in distribution networks. Compliance with IEC 61557-12 ensures a high level of equipment performance, in terms of metrology, and the mechanical and environmental aspects (EMC, temperature, etc.).

Management softwares

- Optional Ethernet module with Webserver function: For measurement monitoring, data exploitation and the export of load curves remotely without a specific software (web browser access).
- Analysis software: For the analysis of events data in order to improve the reliability of the electrical installation.
- Easy Config software: For quick and easy remote device configuration; configuration files can be copied from and sent to the DIRIS A80, or they can be created without communication and sent at a later time. Multiple devices can be configured from a single file, which is especially useful for OEMs and panel builders.

Functions

The DIRIS A80 offers the following functions:

- The monitoring of fault currents
- (Residual Current Monitoring)
- Multi-measurement (current, voltage, frequency, power, ...)
- Energy metering
- Harmonic analysis
- Event detection

Fault currents (RCM)

- Measurement of currents $I_{\Delta n}$ ($I_1+I_2+I_3+I_n$) and IPE (protection conductor)
- Permanent monitoring of $I_{\Delta n}$ and IPE
 - Fault current alarms depending on the load current
 - Record of events $I_{\Delta n}$ and IPE (time, duration and curves stored)
 - Alarm report output

Multi-measurement

- Currents
 - instantaneous: $I_1, I_2, I_3, I_n, I_{system}$,
 - average/maximum average: I_1, I_2, I_3, I_n ,
 - unbalance: I_{unb}
- Voltages & frequency
 - instantaneous: $V_1, V_2, V_3, U_{12}, U_{23}, U_{31}, F, V_{system}, U_{system}$
 - average/maximum average: $V_1, V_2, V_3, U_{12}, U_{23}, U_{31}, F$
 - unbalance: U_{unb}
- Power
 - instantaneous: $3P, \Sigma P, 3Q, \Sigma Q, 3S, \Sigma S$
 - maximum average: $\Sigma P, \Sigma Q, \Sigma S$
 - predictive: $\Sigma P, \Sigma Q, \Sigma S$
 - storing of load curves (60 days with an interval of 10 minutes) for the active, reactive and apparent power: $\Sigma P+/-; \Sigma Q+/-; \Sigma S$

- Power factor $PF, \Sigma PF$
- Instantaneous total tangent phi
- Instantaneous, average and max. average unbalance

Metering

- Active energy: +/- kWh
- Reactive energy: +/- kvarh
- Apparent power: kVAh
- Hours \odot

Harmonic analysis (level 63)

- Total harmonic distortion
 - Currents: $thd I_1, thd I_2, thd I_3, thd I_n$
 - Phase-to-neutral voltage: $thd V_1, thd V_2, thd V_3$
 - Phase-to-phase voltage: $thd U_{12}, thd U_{23}, thd U_{31}$.
- Individual
 - Currents: HI_1, HI_2, HI_3, HI_n
 - Phase-to-neutral voltage: HV_1, HV_2, HV_3
 - Phase-to-phase voltage: $HU_{12}, HU_{23}, HU_{31}$.

Events

- Alarms on all electrical values
- Detection and storing of the last 60 events:
 - overvoltage
 - voltage dips
 - cut-offs
 - overloads.

For each stored event, the DIRIS A80 records the relevant RMS 10 ms interval curves for the voltages $V_1, V_2, V_3, U_{12}, U_{23}, U_{31}$, the currents I_1, I_2, I_3 and I_n . These curves can be synchronised with the event curves $I_{\Delta n}$ and IPE.

Communications⁽¹⁾

- RS485 MODBUS RTU
- Ethernet (MODBUS TCP or MODBUS RTU over TCP and Webserver)
- Ethernet (MODBUS TCP or MODBUS RTU over TCP and Webserver) with RS485 MODBUS RTU gateway

⁽¹⁾ Available as an option (see the following pages).

Front panel



1. Backlit LCD display.
2. Direct access key for the currents, RCM function and alarm reset.
3. Direct access key for voltages and frequency.
4. Direct access key for active, reactive, and apparent powers and power factor.
5. Direct access key for maximum and average current, voltage and power values.
6. Direct access key for harmonic values and the connection and RCM test functions.
7. Direct access key for energies, hour meter and programming menu.

Accessories

Core balance transformer ΔIC
Please consult us.



Plug-in modules

DIRIS® A80



Communication MODBUS®

- RS485 link with MODBUS® protocol (speed up to 38400 bauds).

Ethernet communication

- Ethernet connection with MODBUS TCP or MODBUS RTU over TCP protocol.
- Embedded Webserver function⁽¹⁾.

Ethernet communication with RS485 MODBUS gateway

- Ethernet connection with MODBUS TCP or MODBUS RTU over TCP protocol.
- Connection of 1 to 247 RS485 MODBUS slaves.
- Embedded Webserver function⁽¹⁾.

⁽¹⁾ See "Management softwares for DIRIS" p. 142.

Terminals

DIRIS A80

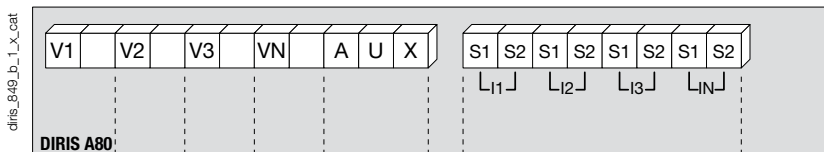

S1 - S2: current inputs

AUX: Auxiliary power supply U_s

V1 - V2 - V3 - VN: voltage inputs

RCM module

1 input / 1 output

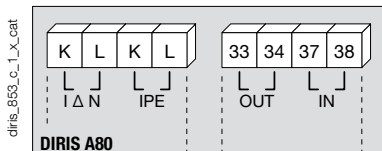

- K-L / IΔN: residual current
- K-L / IPE: ground fault current
- 33-34: relay outputs
- 37-38: opto inputs

RCM module

2 outputs

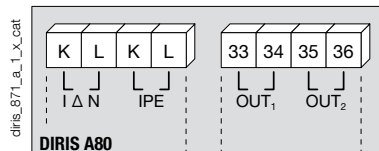

- K-L / IΔN: residual current
- K-L / IPE: ground fault current
- 33-34: relay output n°1
- 35-36: relay output n°2

Memory module

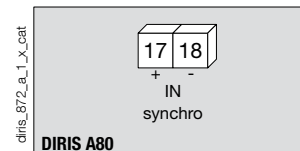

Ethernet module

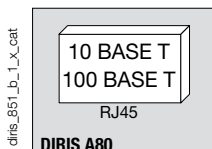

Ethernet module + RS485 MODBUS gateway

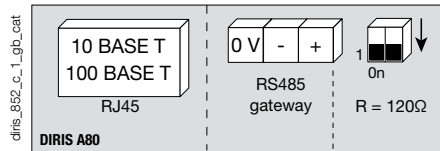

- RS485 gateway resistor.
- R = 120 Ω: selectable internal resistance for RS485 end of line termination.

RS485 MODBUS module

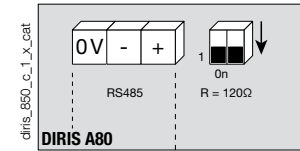

- RS485 link
- R = 120 Ω: selectable internal resistance for RS485 end of line termination.

DIRIS A80

Multifunction meters - PMD + RCM

Monitoring energy and fault currents - dimensions 96x96 mm

Connections

Additional information

Communication via RS485 link

diris_398_c_1_x_cat

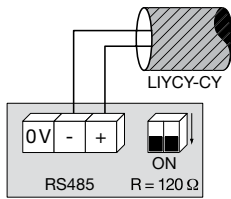

Connection of voltage transformer for HV networks

diris_399_b_1_x_cat

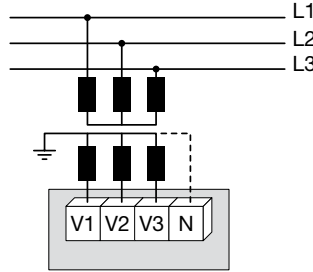

AC & DC auxiliary power supply

diris_400_h_1_gb_cat

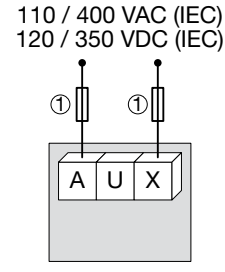

1. Fuses 0.5 A gG / 0.5 A class CC.

Three-phase + N network with RCM

diris_873_a_1_gb_cat

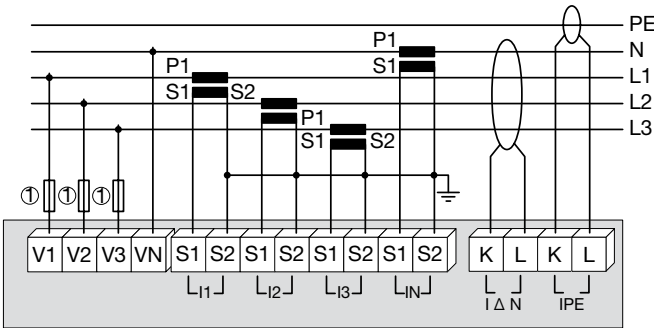

1. Fuses 0.5 A gG / 0.5 A class CC.

Single-phase network with RCM

diris_874_a_1_gb_cat

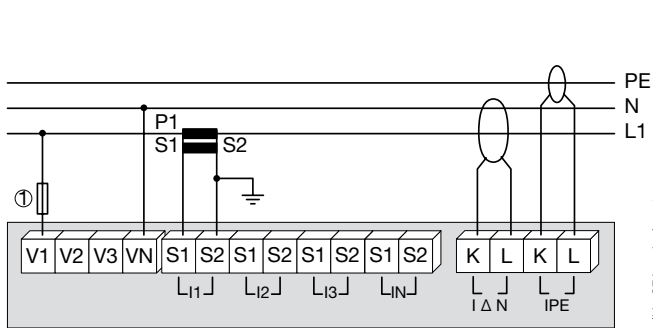

1. Fuses 0.5 A gG / 0.5 A class CC.

Electrical characteristics

Current measurement on insulated inputs (TRMS)	
Via CT primary	9 999 A
Via CT secondary	1 or 5 A
Measurement range	0 ... 11 kA
Input consumption	≤ 0.1 VA
Measurement updating period	1 s
Accuracy	0.2 %
Permanent overload	6 A
Intermittent overload	10 I _n for 1 s
Voltage measurements (TRMS)	
Direct measurement between phases	50 ... 700 VAC
Direct measurement between phase and neutral	28 ... 404 VAC
VT primary	500 000 VAC
VT secondary	60, 100, 110, 173, 190 VAC
Frequency	50 / 60 Hz
Input consumption	≤ 0.1 VA
Measurement updating period	1 s
Accuracy	0.2 %
Permanent overload	800 VAC
Current-voltage product	
Limitation for 1A CT	10 000 000
Limitation for 5A CT	10 000 000
Power measurement	
Measurement updating period	1 s
Accuracy	0.5 %
Power factor measurement	
Measurement updating period	1 s
Accuracy	0.5 %
Frequency measurement	
Measurement range	45 ... 65 Hz
Measurement updating period	1 s
Measurement updating period	0.1 %
Energy accuracy	
Active (according to IEC 62053-22)	Class 0.5 S
Reactive (according to IEC 62053-23)	Class 2
Operating conditions	
Operating temperature	- 10 ... + 55 °C
Storage temperature	- 20 ... + 85 °C
Relative humidity	95 %

Auxiliary power supply	
Alternating voltage	110 ... 400 VAC
AC tolerance	± 10 %
Direct voltage	120 ... 350 VDC
DC tolerance	± 20 %
Frequency	50 / 60 Hz
Consumption	≤ 10 VA
MODBUS communication module	
Link	RS485
Type	2 ... 3 half duplex wires
Protocol	MODBUS® RTU
MODBUS® speed	4800 ... 38400 bauds
Ethernet Communication Module	
Connection	RJ45
Speed	10 base T / 100 base T
Protocol	MODBUS TCP or MODBUS RTU over TCP
Fault current monitoring characteristics (I _{Δn} and I _{PE})	
Inputs I _{Δn} and I _{PE}	
Number of inputs	2
Dedicated core balance transformers	range ΔIC – transformer ratio 600/1
Measurement of fault current I _{Δn} / I _{PE}	6 mA ... 30 A
Accuracy	1 %
Alarms I _{Δn} and I _{PE}	
Thresholds	adjustment depending on the load currents
Time setting	0 to 10 s
Logging	values, dates, durations and curves
Number of events	max. 1000 events
Optocoupler input	
Number	specific to the reference
Power supply	5...24 VDC
Minimum signal width	10 ms
Minimum duration between 2 pulses	20 ms
Type	optocoupler
Alarm outputs	
Number of relays	specific to the reference
Type	230 VAC – 1 A
Max. N° of operations	10 ⁴

Case

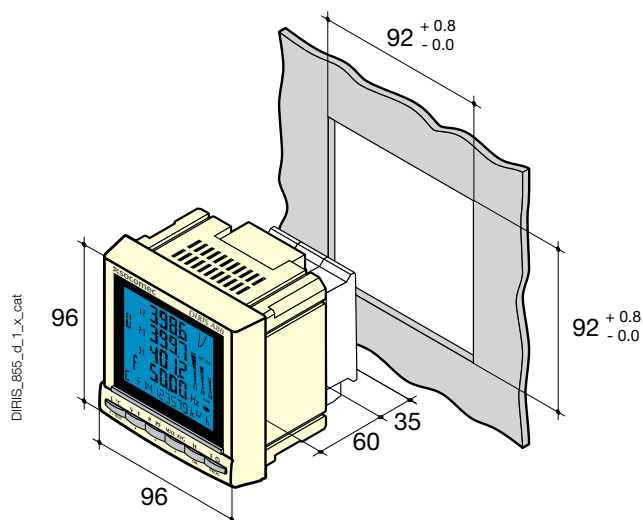

Type	panel mounting
Dimensions W x H x D	96 x 96 x 95 mm
Case degree of protection	IP30
Front degree of protection	IP52
Display type	backlit LCD display
Terminal blocks type	fixed or plug-in
Current connection cross-section	0.5 ... 6 mm ²
Cable cross-section for currents ΔI_n and I_{PE}	0.14 ... 1.5 mm ²
Voltage and other connection cross-section	0.2 ... 2.5 mm ²
Weight	560 g

References

Basic device	DIRIS A80
Type	Reference
With 2 outputs	4825 0213
With 1 input / 1 output	4825 0214
Options	
Plug-in modules	Reference
RS485 MODBUS [®] communication	4825 0092
Ethernet communication (embedded Ethernet Webserver) ⁽¹⁾	4825 0203
Ethernet communication + RS485 MODBUS gateway (embedded Ethernet Webserver) ⁽¹⁾	4825 0204

(1) Dimensions: 2 slots.

Accessories	To be ordered in multiples of	Reference
Description of accessories		
IP65 protection	1	4825 0089
Panel mounting kit for a 144 x 96 mm cut-out	1	4825 0088
Fuse disconnect switches for the protection of voltage inputs (type RM) 3 poles	4	5601 0018
Fuse disconnect switches for the protection of the auxiliary supply (type RM) 1 pole + neutral	6	5601 0017
Fuses type gG 10x38 0.5 A	10	6012 0000
Ferrite to be associated with communication modules	1	4899 0011
Current transformer range	1	See page 98

Core balance transformer ΔIC	Toroid diameter (mm)	Reference
Type		
$\Delta IC \varnothing 15$	15	4950 6015
$\Delta IC \varnothing 30$	30	4950 6030
$\Delta IC \varnothing 50$	50	4950 6050
$\Delta IC \varnothing 80$	80	4950 6080
$\Delta IC \varnothing 120$	120	4950 6120
$\Delta IC \varnothing 200$	200	4950 6200
$\Delta IC \varnothing 300$	300	4950 6300
Management softwares for DIRIS		See page 142

Services & Technical Assistance

- Technical site audits and solution specification, commissioning, maintenance, training... Our Services & Technical Assistance experts offer you personalised support to ensure success with all your projects.





DIRIS N300/N600

Network analysers

Network quality control and analysis system

Single-circuit metering,
measurement &
analysis



The solution for

- > Industry
- > Infrastructure
- > Health care buildings
- > Data centres



Strong points

- > Easy to use
- > Customisable
- > Powerful
- > Accurate
- > Conformity to standard EN 50160

Conformity to standards

- > IEC 61557-12
- > IEC 61000-4-30
- > IEC 62053-22 class 0.2 S
- > IEC 62053-23 class 2
- > EN 50160



Function

DIRIS N300 / N600 are multifunction network analysers designed for in-depth analysis of electrical networks in order to improve their availability and efficiency. They actively contribute to procedures for optimising the operation of your electrical networks. They enable you to:

- improve the efficiency of the facility,
- reduce production costs,
- optimise operating costs,
- optimise maintenance costs,

To ensure these aims are achieved, the DIRIS N includes the following functions:

- measurement of electrical values and temperatures,
- management of energy and allocation of other utilities (water, gas),
- monitoring of all parameters,
- control/command of apparatus,
- analysis of the network quality (waveform, EN 50160 report),
- communication.

Advantages

Easy to use

The DIRIS D600 interface enables easy access to the DIRIS N's menus and clearly displays numerical values and graphs on its large colour TFT screen.

Customisable

Optional input/output modules can be utilised to facilitate, for example, switchboard automation control. These modules can be installed after the initial installation, enabling the implementation of additional functions.

Powerful

The DIRIS N600 can detect transient overvoltages down to 1 microsecond.

Accurate

High accuracy of the measured electrical values (0.1% for I and U).

Conformity to standard EN 50160

EN 50160 is a standard which defines the characteristics and events relating to the quality of electrical networks. The DIRIS N fully complies to this standard.

Principle diagram

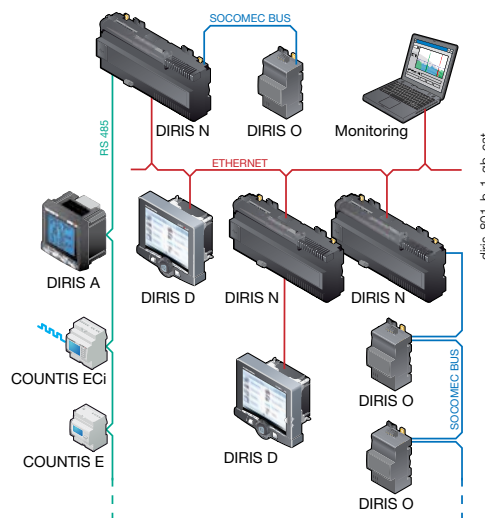

	DIRIS N300 multifunction analyser	DIRIS N600 qualimeter
Advanced multi-measurement	•	•
Measurement history	•	•
Harmonics	•	•
Monitoring	•	•
Load curves	•	•
Dips/Outages/Voltage surges	•	•
Unbalance	•	•
Vector diagram	•	•
Control command (options)	•	•
Interharmonics measurement	•	•
Analysis of transient states	•	•
Flicker	•	•
EN 50160 report	•	•

Functions

The DIRIS N is a true system made up of functional components:

- measurement acquisition and processing: DIRIS N300/N600
- TFT graphic colour interface: DIRIS D 600 (option of using a single DIRIS D 600 for several DIRIS N)
- remote input/output modules: DIRIS O.

In addition, the DIRIS N can provide an interface between products communicating via MODBUS, such as DIRIS A or COUNTIS ECi, for example, using an Ethernet network via an RS485 port to centralise information for monitoring.

General characteristics of the DIRIS N300 and N600

The vast majority of the functions below are available as numerical values (instant, average, minimum and maximum values), graphs (wave captures and 1/2 period RMS) and logs.



Measurements:

- Currents, voltages, frequency (instant, average, minimum and maximum).
- Direct, inverse and homopolar voltages.
- Voltage unbalance.
- Active, reactive, apparent and predictive power.
- Power factor.
- Fresnel diagram.
- Temperatures.



Energy management:

- Active, reactive and apparent energy meters.
- Impulse meters (up to 20 meters).
- Timestamped meters (up to 8 meters).
- Load curves.



Monitoring:

- Display of an alarm and status log.
- Indication of the parameter concerned, the status at time T, the duration and date/time of the start and end of the event.



Control/Command (only with the DIRIS O):

- Controls and commands the position of the remote devices.
- Programmes the logical functions to create automatic processes.



Network and event quality analysis:

- Dips, surges and voltage cut-offs.
- Crest factor.
- Voltage and current harmonics.
- Mains signalling voltages.



Communication:

- RS485 using MODBUS.
- 10BaseT and 100BaseT Ethernet (MODBUS/TCP).
- 2 USB ports (host/device).
- Open CAN (internal bus for DIRIS O modules).

DIRIS N600:

The user also has the following functions:

- Flicker (Pst and Plt).
- EN 50160 report.
- Voltage transients (sampling 1 μ s).
- Voltage and current interharmonics.

A hub of innovation

The **DIRIS N**, developed using innovative technology, has enabled some functions to reach a new level.

Measurements

Optimal calculation functions and sampling in the range of 1 μ s ensuring a very high-level of precision when measuring as shown below:

- Voltages and currents in class 0.1
- Active energy in class 0.2 as per IEC 62053-22
- Harmonics in class 1.

Operation

The DIRIS D600 colour TFT interface module gives the user easy access to all the installation's parameters and clearly displays both numerical values and graphs.

Data stored on the DIRIS N's internal memory can be downloaded onto a USB key via the DIRIS D600's USB port.

Installation

The DIRIS N is designed to be located within close proximity to the installation being monitored in order to greatly reduce the length of cabling for measurement sensor connection (current and voltage transformers).

Using a remote interface module avoids having multiple cables connected on the inside of the panel door; only an RJ45 cable is required. In the same way, power is supplied to the additional DIRIS O modules directly via the communication bus, thus avoiding the use of yet more cables.



diris_759_a_1_gh_cat

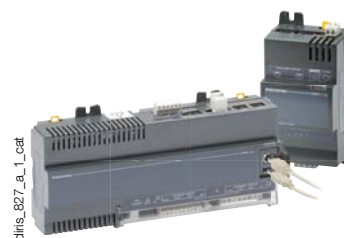

diris_827_a_1_cat

DIRIS N300/N600

Network analysers

Network quality control and analysis system

Power Quality Suite software

The DIRIS N300/N600 network analyser is delivered with this software package which allows all features to be managed remotely. Simple and intuitive, these software tools ensure the functions of:

PQS - Display software

Displays the real time remote monitoring of your installation

This software reproduces the screens of the DIRIS D600 identically on a PC. Any user can therefore access all the data to save time and increase readability:

- Measurements
- Energies
- Events

- Quality Parameters
- Diagnosis.
- Configuration.

Communication between the PC and the DIRIS N units is via Ethernet. A simultaneous display of several DIRIS N is possible.

All measurements displayed on a single screen

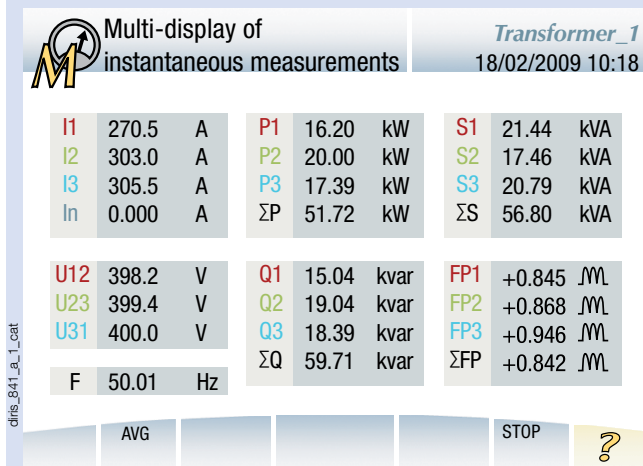

Voltage waveforms displayed

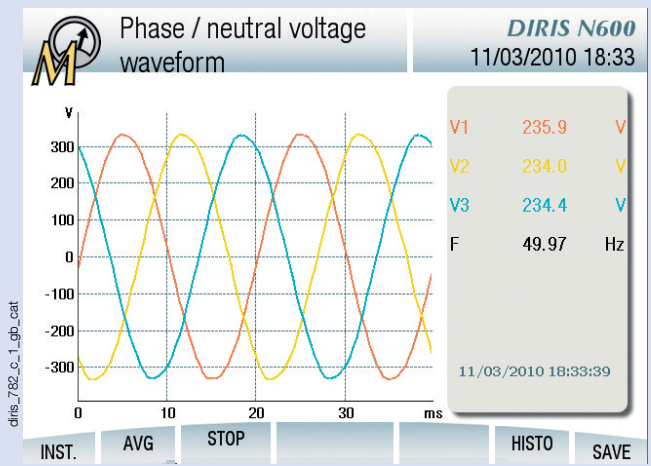

Load curve displayed

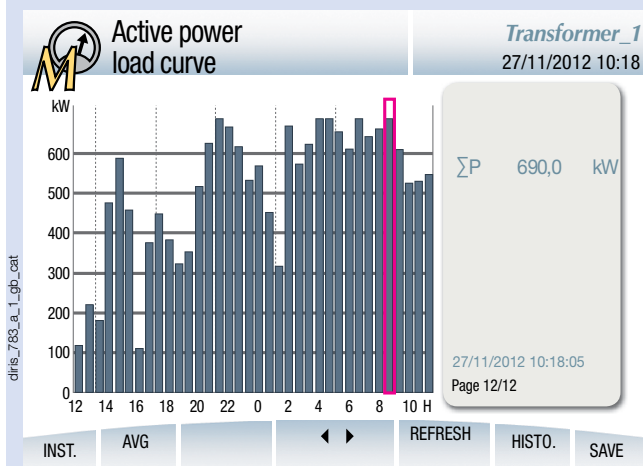

Total and partial consumption displayed per time slot

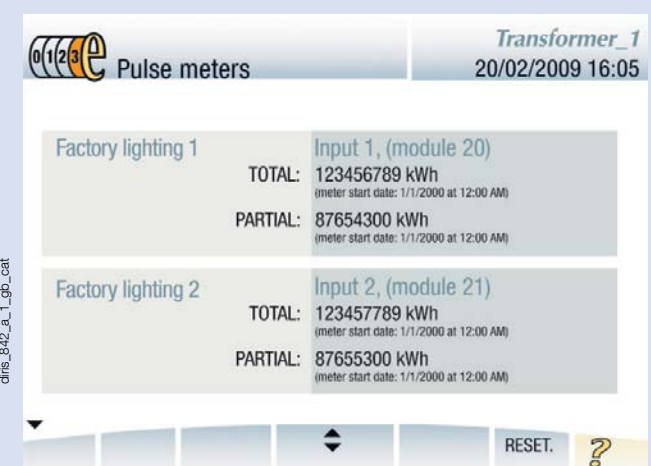

PQS - Settings software

Configuration software for simple and fast parameter setting

The configuration software enables the user to modify, and to quickly adapt, the configuration parameters of the network analyser. The following parameters are available:

- Networks
- Events
- EN 50160 report thresholds
- Pulse meter

- Histories and load curves
- Control/command functions linked to DIRIS O remote modules.

A maintenance function allows the connection and operation of the DIRIS Ns to be checked after they have been configured.

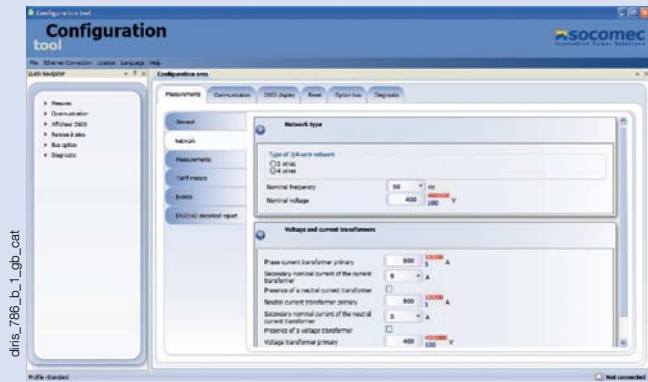

PQS - Analysis software

Quality parameter analysis

This software analyses the DIRIS N300/N600 quality parameters to improve the efficiency of your electrical installation.

It provides the following functions:

- Classification of voltage dips, cuts and surges (Discip table).
- EN 50160 automatic reports (voltages, frequencies, harmonics, flickers...).

- Automatic detection of "out of limit" events.
 - Timestamp EN 50160 events list (surges, dips, cut-offs...).
- The application enables reports to be issued for periods which can be customised by the user.
- The temporal display screen allows rapid access to information relating to the desired period.

Event log: Display

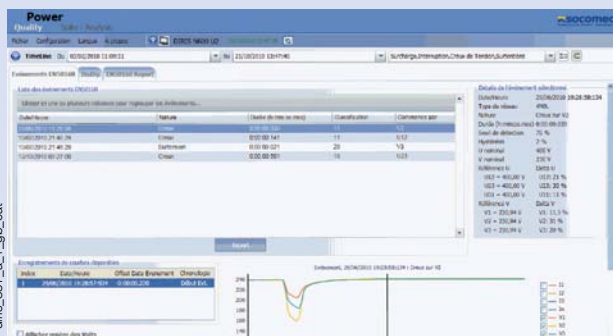

Timeline: chronology of events

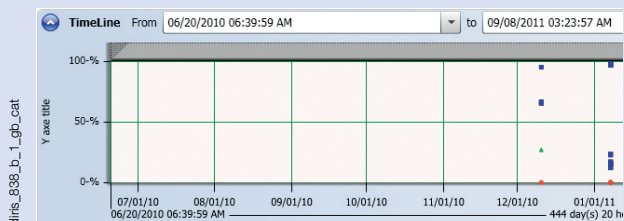

Contractual number of events



EN 50160 report Display



DIRIS N300/N600

Network analysers

Network quality control and analysis system

Case

DIRIS N300/N600

Base-mounting



diris_798_a_1_cat

Overall dimensions

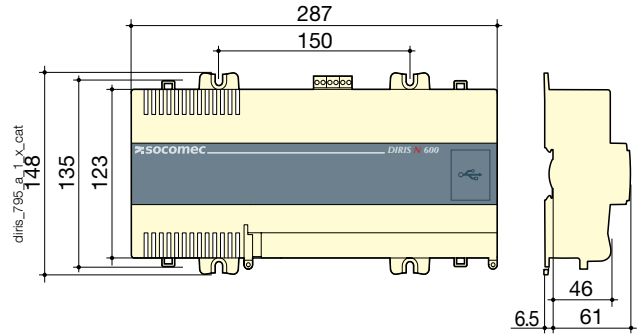

DIN-rail mounting



diris_794_a_1_cat

DIRIS D600

Remote interface

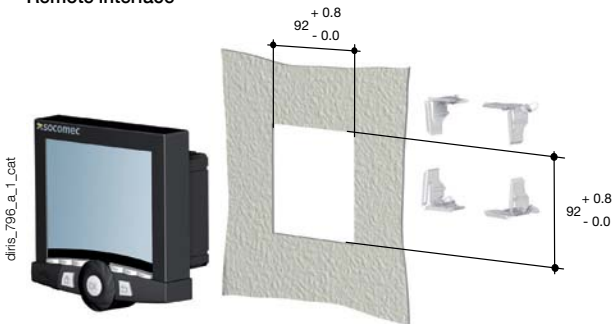

diris_796_a_1_cat

Overall dimensions

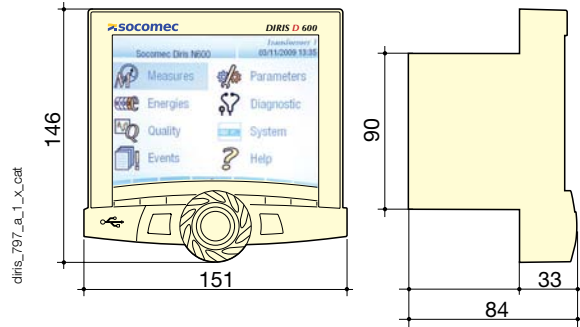

diris_797_a_1_x_cat

DIRIS O

Base-mounting



diris_798_a_1_cat

DIN-rail mounting

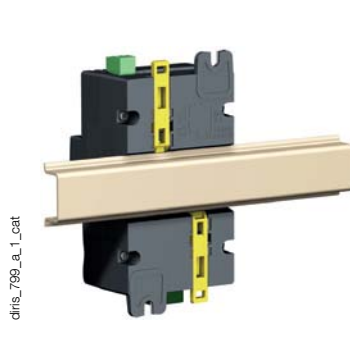

diris_799_a_1_cat

Overall dimensions

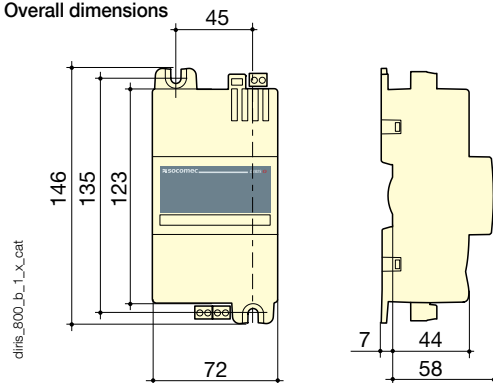

diris_800_b_1_x_cat

Options

DIRIS D 600: an ergonomic remote colour TFT graphic interface



1. High-definition colour TFT display.
2. Direct access buttons.
3. Control by rotating wheel.

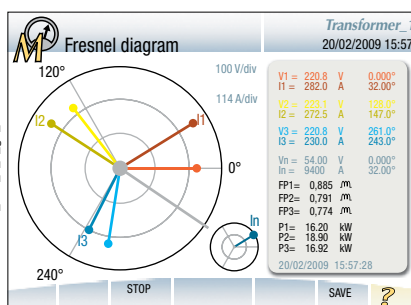
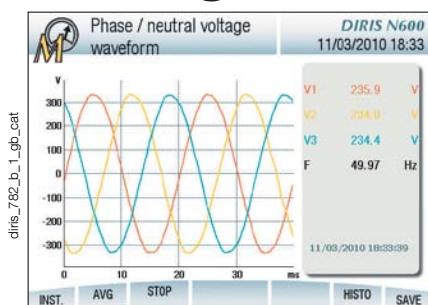

The DIRIS D600 is an interface with a high-definition colour TFT display which allows adaptable, local or remote viewing of the functions of the DIRIS N300 and N600.

A single DIRIS D 600 interface can be used to display information from several DIRIS N through windows on the screen dedicated to measurement, analysis of consumption and energy quality, along with their associated events and curves.

DIRIS O: for extended control-command functions

DIRIS O are optional analogue and/or digital input/output modules which can extend the system's functions by taking into account all information relevant to facility supervision (energies, alarms, etc.).

They communicate with the DIRIS N via a SOCOMEC bus.

They enable you to:

- Acquire and apply the positions of breaker components, contactors, sensors, etc.
- Centralise pulses from water, gas and electricity meters.
- Apply information from analogue sensors (temperature, flow, humidity level, pressure, etc.).
- Actuate breaker components, perform load shedding actions upon alarms. The inputs/outputs can be activated via logic equations.



Characteristics

	DIRIS N300/N600	DIRIS D600 remote interface	DIRIS O 4 inputs - 2 outputs	DIRIS O: 2 analogue inputs 0/4...20 mA	DIRIS O: 2 analogue outputs 0/4...20 mA
Auxiliary power supply					
Alternating voltage	110 ... 240 VAC				
AC tolerance	± 10 %				
Frequency	50 / 60 Hz				
Direct voltage	48...250 VDC	48 VDC ⁽¹⁾	48 VDC ⁽¹⁾	48 VDC ⁽¹⁾	48 VDC ⁽¹⁾
DC tolerance	± 10 %	± 10 %	± 10 %	± 10 %	± 10 %
Connection	2.5 mm ² pull-out 2 point terminal block	2.5 mm ² pull-out 2 point terminal block	2.5 mm ² pull-out 2 point terminal block	2.5 mm ² pull-out 2 point terminal block	2.5 mm ² pull-out 2 point terminal block
Mechanical					
Consumption		10 W	1.5 W	1.3 W	2.5 W
Type	modular		modular	modular	modular
Number of modules	16		4	4	4
Dimensions W x H x D	287 x 123 x 67.5	151 x 146 x 84	72 x 148 x 65	72 x 148 x 65	72 x 148 x 65
Cut-out		92 x 92			
Vibrations	IEC 60068-2-6 compliant	IEC 60068-2-6 compliant	IEC 60068-2-6 compliant	IEC 60068-2-6 compliant	IEC 60068-2-6 compliant
Protection degree	IP40 (front panel), IP20 (unit)	IP52	IP52 (front panel), IP20 (unit)	IP40 (front panel), IP20 (unit)	IP 40 (front panel), IP20 (unit)
Weight	1200 g	600 g	200 g	210 g	220 g

(1) Auxiliary supply or via DIRIS N300/N600 (limited to 15 W) or Power over Ethernet or Power over Can

	DIRIS N300/N600	DIRIS D600 remote interface	DIRIS O 4 inputs - 2 outputs	DIRIS O 2 analogue inputs 0/4...20 mA	DIRIS O 2 analogue outputs 0/4...20 mA
Communication					
Link	RS485	ETHERNET	ETHERNET	BUS OPTION	BUS OPTION
Type	2 half duplex wires	2 half duplex wires			
Protocol	MODBUS RTU	MODBUS [®] TCP or proprietary	Proprietary in TCP mode	Proprietary in CAN mode	Proprietary in CAN mode
MODBUS [®] speed	9.6 ... 115.2 kbauds				
Address	000 ... 256				
Connection	2.5 mm ² pull-out 3 point terminal block	1 x RJ 45 8 point straight cable	1 x RJ 45 8 point straight cable	2 x RJ 45 8 point straight cable	2 x RJ 45 8 point straight cable

Characteristics

Characteristics of the PMD (IEC 61557-12)	
Evaluation of the power supply quality (possible function)	-
PMD classification	SD
Temperature	K55
Humidity + Altitude	-
Operating performance class of active power or active energy (if possible function)	0.2
Startup duration	50 seconds
Characteristics of the functions/ Evaluation of the power supply quality (IEC 61557-12)	
P (Total active power) - class 0,2	5 % I _n to 2 I _n
Qv (reactive power) - class 1	5 % I _n to 2 I _n
Sv - class 0.2	5 % I _n to 2 I _n
Ea - class 0.2	5 % I _n to 2 I _n
Erv - class 1	5 % I _n to 2 I _n
Eapv - class 0.2	5 % I _n to 2 I _n
f - class 0.02	F _{nom} ± 15 %
l - class 0.1	0.1 I _n to 2 I _n
In / Inc - class 0.1	0.1 I _n to 2 I _n
U - class 0.1	
PFv - class 0.5	PF = 0.5 lag. to 0.5 lead.
Pst / Pit - class 5 (complies IEC 61000-4-15)	0 ... 20
Udip - class 0.2	5 % U _n to U _n
Uswl - class 0.2	U _n to 120 % U _n
Utr	0 ... 6 kV
Uint - class 0.2	0 ... 5 % U _n
Unba - class 0.2	
Unb - class 0.2	
Uh - class 1	
THDu - class 1	
THD-Ru - class 1	
Ih - class 1	
THDi - class 2	
THD-Ri - class 1	
Msv - class 1	
Measurements	
Network type	three-phase without neutral or with neutral
Number of power outlets	3 or 4
Measurement category	600V cat III (IEC 61010-1)
Measurement method class	B (A except for temporal aggregation) (IEC 61000-4-30)
TRMS	up to level 50
Measurement sampling frequency	10240 Hz (at the nominal network frequency)
Transient sampling frequency	1 MHz that is 1 μs
Instantaneous measurements refresh frequency	one second
Plot refresh frequency	1 ... 60 minutes
Event log refresh frequency	1 ... 60 s
Voltage inputs	
Number of voltage inputs	3 Phase + Neutral + Earth
Nominal voltage without TP	346 VAC (phase/Neutral) and 600 > VAC (phase/phase)
Voltage transformer	primary maximum: 630 kVAC / Secondary: 60/100/110/115/120/173/190 VAC
Permanent overload	800 VAC
Frequency	45 ... 65 Hz
Insulation	600 V cat III
Connection	2.5 mm ² pull-out 3 point terminal block
Current inputs	
Number of current inputs	3 Phase + Neutral
Nominal current without CT	5 A
Current transformers	primary: max 10000 A / Secondary: 1 or 5 A
Input consumption	< 0.3 VA
Permanent overload	20 A
Intermittent overload	20 I _n / 1s
Insulation	main
Connection	6 mm ² 8 point fixed terminal block
USB	
Host (low power : 100 mA max)	1
Device	1

Memory	
Memory size	128 MB
Environment	
Max. operating temperature	-10 ... +55 °C
Max. storage temperature	-25 ... 70 °C
Humidity	0 ... 95 % RH
Salt spray	EN 60068-2-52
Protection degree	IEC 60259
Sine vibrations	IEC 60068-2-6
Dry heat test (operation and storage)	IEC 60068-2-2
Wet heat cyclic test	IEC 60068-2-30
In-operation and storage cold test	IEC 60068-2-1
Product standards and certification	
Product standard	IEC 61557-12 ed. 1
Active energy metering	IEC 62053-22 class 0.2S
Reactive energy metering	IEC 62053-23 (class 2)
Measurement standards and certification	
Harmonics and interharmonics measurement method	IEC 61000-4-7
Flicker measurement method	IEC 61000-4-15
Supply power quality measurement method	IEC 61000-4-30
Characteristics of the voltage supplied by public distribution networks	EN 50160
Communication standards and certification	
RS485	TIA-485A TSB-89-B IEE 802-3AF
Ethernet	802-1.3-2005_Section1 802-1.3-2005_Section2
Protocol standards and certification	
RS485	MODBUS
Ethernet	MODBUS
USB	USB 2.0
CAN	ISO11898-2
DIRIS D600 interface	
Display	TFT
Dimensions	640 x 480 pixels
Dimension	115.2 x 86.4 mm
DIRIS O 4i2o-d (4 inputs/2 outputs): inputs	
Number	4
Type	phototransistors
Power supply	10 ... 30 VDC
Minimum current	1 mA
Main insulation for < 300 VAC Ph/N network	2.5 kVAC rms 1 minute
Leakage path	> 3 mm
Number of switchings	10 ⁸ operations
DIRIS O 4i2o-d (4 inputs/2 outputs): outputs	
Number of operations	≥ 10 ⁵
Power supply	230 VAC - 250 VDC - 0.2 A - 1500 VA - 50 W
Number of relays	2
Leakage path	> 3 mm
Main insulation for < 300 VAC Ph/N network	2.5 kVAC rms 1 minute
DIRIS O 2i-a inputs (2 analogue inputs)	
Number	2
Scale	0 / 4 ... 20 mA
Accuracy	≤ 1 % of full scale (which is ≤ 0.2 mA)
Max. impedance of inputs	200 Ω
Main insulation for < 300 VAC Ph/N network	2.5 kVAC rms 1 minute
Leakage path	> 3 mm
DIRIS O 2o-a outputs (2 analogue outputs)	
Number of outputs	2
Scale	0 / 4 ... 20 mA
Load resistance	600 Ω
Accuracy	≤ 0.5 % of full scale (which is ≤ 0.1 mA)
Maximum current	25 mA
Main insulation for < 300 VAC Ph/N network	2.5 kVAC rms 1 minute
Leakage path	> 3 mm

Terminals

DIRIS N300/N600

Lower terminal blocks

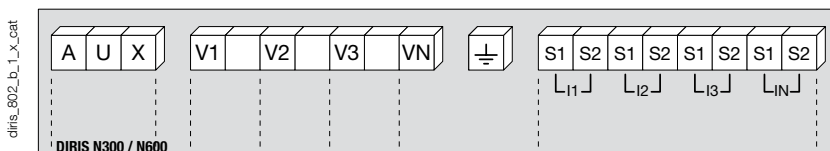

Upper terminal blocks

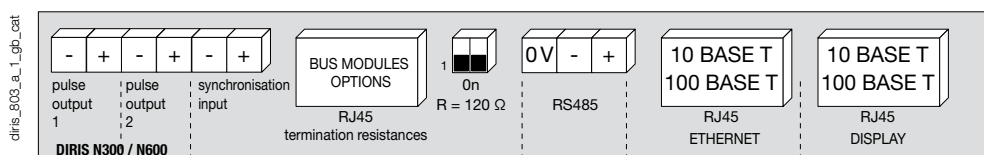

DIRIS O

Upper terminal blocks (shared by all modules)

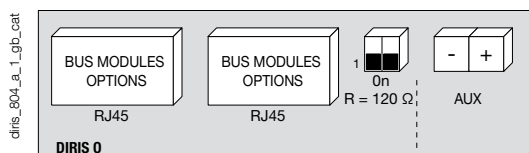

4 inputs / 2 outputs digital

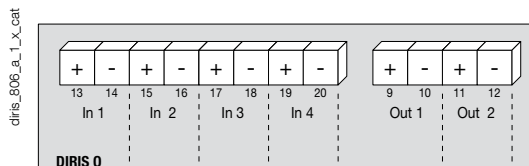

2 analogue outputs, 0/4-20 mA

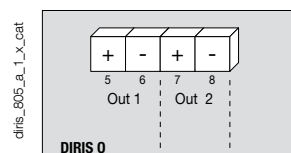

2 analogue inputs, 0/4-20 mA

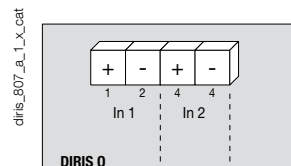

References

Description	DIRIS N300/N600 Reference	
DIRIS N300	4826 0001	
DIRIS N600	4826 0002	
Optional Description	DIRIS D600 Reference	
DIRIS D600 (remote interface)	4826 0003	
Description	DIRIS O Reference	
DIRIS O 4i2o-d (4 digital inputs/2 digital outputs)	4826 0071	
DIRIS O 2i-a (2 analogue inputs)	4826 0072	
DIRIS O 2o-a (2 analogue outputs)	4826 0073	
Accessories		
Description of accessories	To be ordered in multiples of	Reference
Fuse disconnect switches for the protection of voltage inputs (type RM) 3 poles	4	5601 0018
Fuse disconnect switches for the protection of the auxiliary supply (type RM) 1 pole + neutral	6	5601 0017
Fuses type gG 10x38 0.5 A	10	6012 0000
Current transformer range		See page 98

Services & Technical Assistance

- Technical site audits and solution specification, commissioning, maintenance, training... Our Services & Technical Assistance experts offer you personalised support to ensure success with all your projects.





Selection guide

Current transformers

Type	TRB 60	TRB 70	TRB 135	TCA 14	TCA 21	TCA 22	TCB 17-20	TCB 26-30	TCB 28-30	TCB 26-40	TCB 32-40	TCB 44-50
Dimensions	Primary wound			Cable-through			Bar or cable-through					
Class	0.5	0.5	0.5	1	0.5/1	1	1	0.5/1	0.5/1	1	0.5/1	0.5/1
0.2S version			(1)			(2)		T2CB 26-30			T2CB 32-40	
	<i>p. 99</i>			<i>p. 101</i>			<i>p. 102</i>					

Rating (A)

0.5												
5	5											
10	...											
15	20											
20		5										
25		...										
30		40										
40												
50												
60			25	*								
75			...	25								
80			150	...								
100				150								
125												
150					40							
160					...							
200					150							
250												
300												
400												
500												
600												
750												
800												
1000												
1200												
1250												
1500												
1600												
2000												
2500												
3000												
4000												
5000												

Dimensions

Height	75.5	85.5	85	65	65	65	65	61	70	75.5	88.5	98.5
Width	61	71	135	45	45	49.5	49.5	75.5	49.9	61	71	86
Depth	35	45	60	30	30	35	50	48	68	48	58	58
Cable (Ø mm)				14	21	22.5	17.5	26	28	26	32	44
Bar 1							20x5	30x10	30x10	32x18	40x10	50x12
Bar 2								20x10 (x2)		40x12	30x5 (x2)	40x10 (x2)
Bar 3												

* Class 1.

(1) Please see T2RB 115 for a primary wound 0.2S version. Dimensions are different from TRB 135.

(2) Please see T2CA 225 for a cable-through 0.2S version. Dimensions are different from TCA 22.

TCB 44-63	TCB 55-80	TCD 85-100	TCB 100-125	TBA 60	TBA 80	TBA 100	TBA 103	TBA 127	TO 23	TO 58	TO 812	TO 816
Bar or cable-through				Bar-through					Split-core			
0.5	0.5	0.5	0.5	0.5/1	0.5	0.5	0.5	0.5	1/3	0.5/1	0.5/1	0.5
T2CB 44-63						T2BA 100	T2BA 103	T2BA 127				
<i>p. 103</i>				<i>p. 106</i>					<i>p. 110</i>			

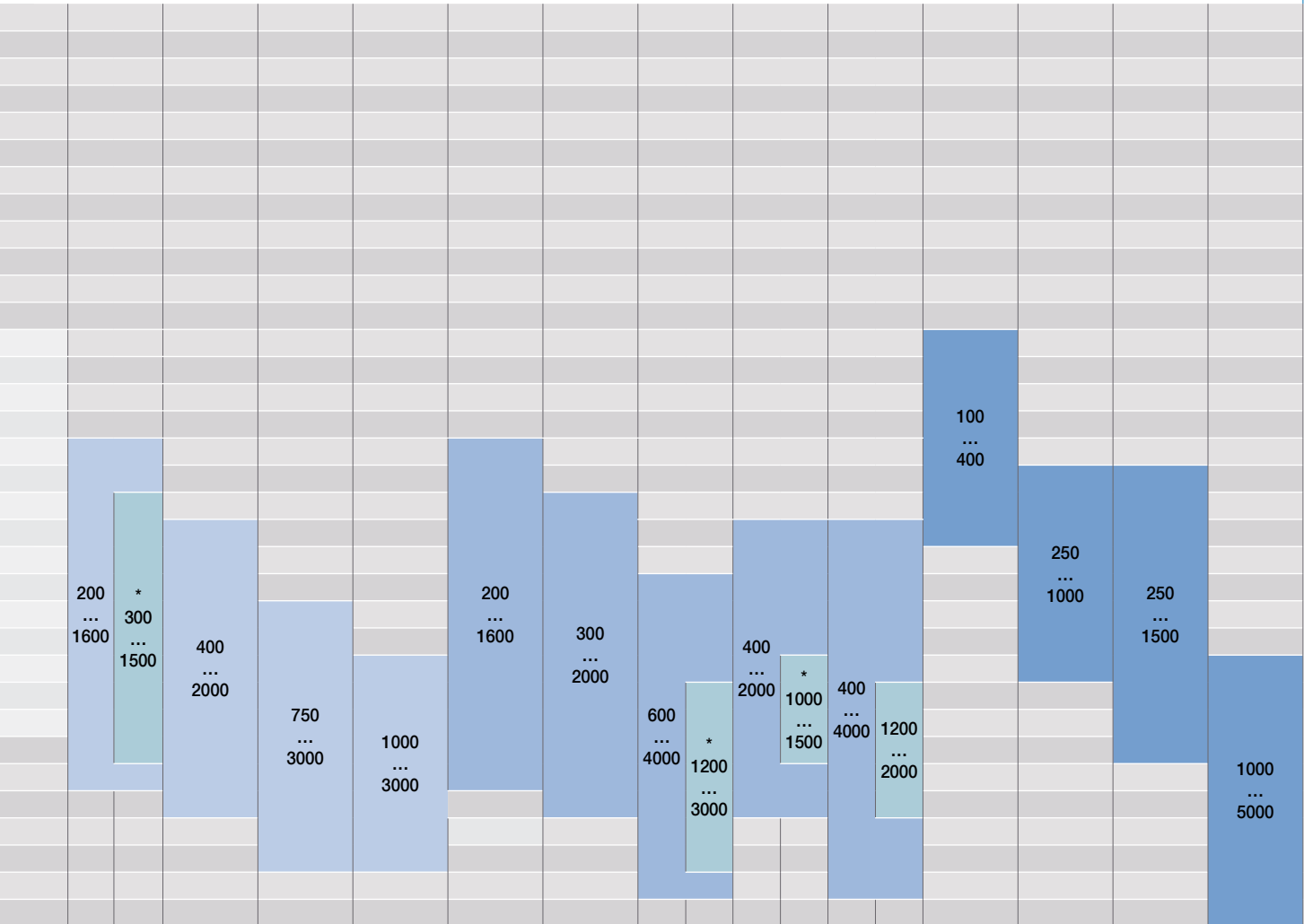

105.5	123.5	184.8	184.8	129	117	167	150	175	106	158	198	243
96	120	172	172	88	96	129	99	100	93	125	155	195
58	58	52	52	48	68	78	58	55	58	58	58	79
44	55	85	100									
63x10	80x10	100x10	123x30	60x30	84x34	100x55	103x41	128x38	33x23	85x55	125x85	165x85
50x10 (x2)	60x30	80x10 (x3)	100x10 (x3)									
	60x10 (x2)											

Current transformers

Measurement devices
from 5 to 5000 A



The solution for

- > Industry
- > Office buildings



Strong points

- > An adapted accuracy class
- > A wide range of ratings and dimensions
- > Quick and easy to mount

Conformity to standards

- > IEC 61869-2
- > IEC 61439-1



Available on request

SOCOMEK also offer customised solutions:

- > 1 A secondary
- > Double or triple primary ratio
- > Voltage transformer
- > Summation CTs

Function

SOCOMEK current transformers deliver to the secondary a standard current proportional to the primary current and adapted to the rating of the associated device. They are equipped as standard with removable terminal covers and double terminals allowing the secondary to be short-circuited without any risk.

They are mounted using two screw-on metal brackets or, in certain cases, by a clip-on DIN-rail fastener. The connections are made by screws or by fast-on terminals.

- Accuracy class: 0.2s — 0.5 or 1.
- Dielectric quality: 3 kV — 50 Hz — 1 min.
- Operating frequency: 50 — 60 Hz.
- Permanent overload: 1.2 In.
- Insulation class: E (120 °C).

Advantages

An adapted accuracy class

In order to get the best of your DIRIS multifunction meters and COUNTIS energy meters, we can provide current transformers with the following accuracy classes: 0.2s; 0.5; 1 or 3.

A wide range of ratings and dimensions

Your measurement process can be optimised whatever your needs in terms of ratings, space requirements, conductor sizing or accuracy class. A wide range of combinations are available in our standard range with specific versions available on request (other ratios, tropicalisation and specific frequency, class or burden).

Quick and easy to mount

Our current transformers are adapted to any type of mounting: edgewise or flat mounting, DIN-rail or back-plate mounting. Implementation is easy and rapid.

Composition of the range

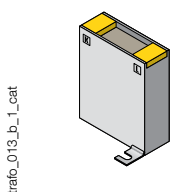

Primary wound moulded case CT

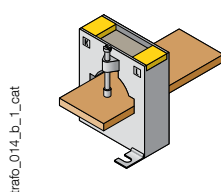

Bar or cable-through CT

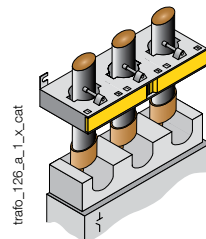

Bar or cable-through three-phase CT

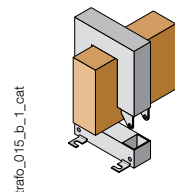

Bar-through split-core CT

Primary wound moulded case CT

References

Primary	Secondary ⁽¹⁾	TRB 60		TRB 70		T2RB 115		TRB 135	
		Class 0.5	Reference	Class 0.5	Reference	Class 0.2s	Reference	Class 0.5	Reference
5 A	5 A	2.5 VA	192 x 0505	10 VA	192T 0521				
10 A	5 A	2.5 VA	192T 0510	10 VA	192T 0522				
15 A	5 A	2.5 VA	192T 0515	10 VA	192T 0523				
20 A	5 A	2.5 VA	192T 0520	10 VA	192T 0524				
25 A	5 A			10 VA	192T 0525	7.5 VA	192U 0402	10 VA	192T 0603
30 A	5 A			5 VA	192T 0530	7.5 VA	192U 0403	10 VA	192T 0607
40 A	5 A			5 VA	192T 0541	7.5 VA	192U 0404	10 VA	192T 0604
50 A	5 A			5 VA	192T 0551	7.5 VA	192U 0405	10 VA	192T 0605
60 A	5 A					7.5 VA	192U 0406	10 VA	192T 0606
75 A	5 A					7.5 VA	192U 0407	10 VA	192T 0608
80 A	5 A					7.5 VA	192U 0408	10 VA	192T 0609
100 A	5 A							10 VA	192T 0610
125 A	5 A					7.5 VA	192U 0412	10 VA	192T 0612
150 A	5 A					7.5 VA	192U 0415	10 VA	192T 0615

(1) Secondary 1 A: on request.

Accessories

Description of accessories	TRB 60 Reference	TRB 70 Reference		TRB 135 Reference
DIN-rail mounting	192T 0003	192T 0005 ⁽¹⁾		
Sealable cover	192T 0105	192T 0103		192T 0101 ⁽²⁾

(1) Not available for 50 A rating

(2) For 125 and 150 A ratings, use reference 192T 0103.

CT Plug-in transducer (CEA-VA)

Power supply	Output	TRB 60 Reference	TRB 70 Reference
Self-supplied	0-20 mA / 0-10 VDC	192Y 0015	192Y 0025 ⁽¹⁾
230 VAC	0-20 mA / 0-10 VDC	192Y 0215	192Y 0225 ⁽¹⁾
24 VDC	0-20 mA / 0-10 VDC	192Y 0115	192Y 0125 ⁽¹⁾

(1) Not available for ratings 40 and 50 A

CT Plug-in transducer (CEA-VA4)

Power supply	Output	TRB 60 Reference	TRB 70 Reference
230 VAC	4-20 mA / 0-10 VDC	192T 0255	192Y 0265 ⁽¹⁾
24 VDC	4-20 mA / 0-10 VDC	192Y 0155	192Y 0165 ⁽¹⁾

(1) Not available for ratings 40 and 50 A

Certificate of performance

Each class 0.2s current transformer is supplied with an individual certificate of performance, attesting to its accuracy.

Current transformers

Measurement devices

from 5 to 5000 A

Primary wound moulded case CT (continued)

Dimensions

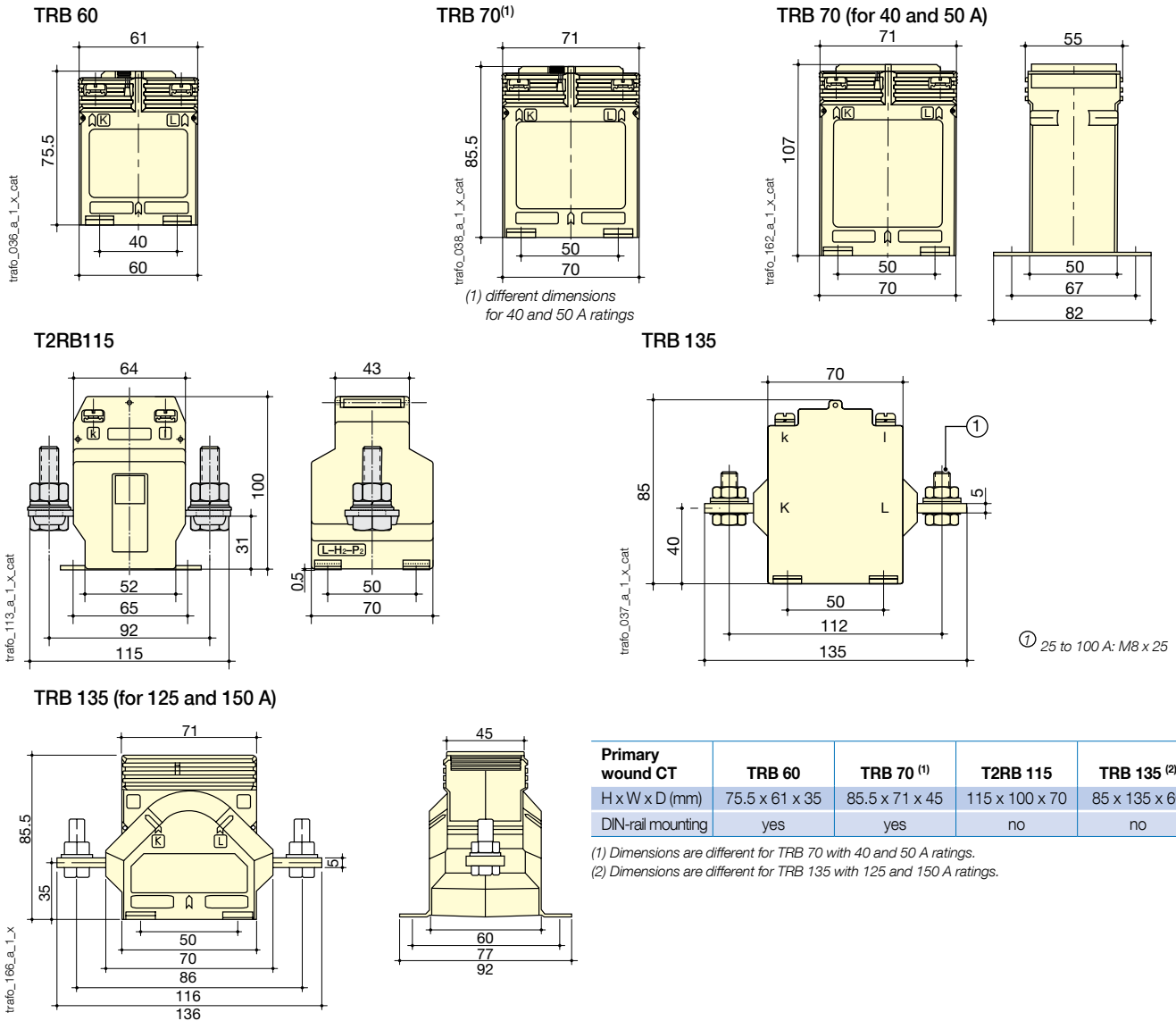

Primary wound CT	TRB 60	TRB 70 (1)	T2RB 115	TRB 135 (2)
H x W x D (mm)	75.5 x 61 x 35	85.5 x 71 x 45	115 x 100 x 70	85 x 135 x 60
DIN-rail mounting	yes	yes	no	no

(1) Dimensions are different for TRB 70 with 40 and 50 A ratings.
 (2) Dimensions are different for TRB 135 with 125 and 150 A ratings.

Associated transducers

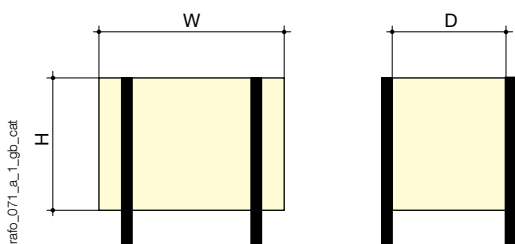
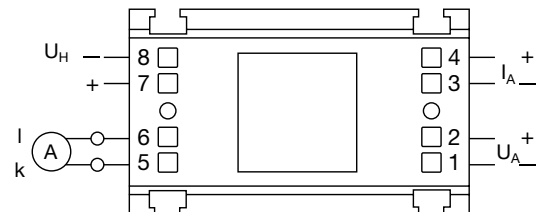
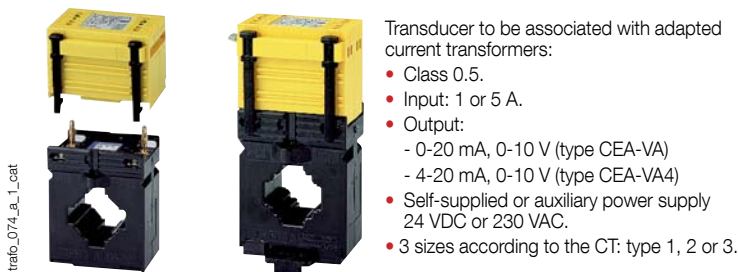

Dimensions (mm)

Converter	For CT	Height (mm)	Width (mm)	Depth (mm)
Type 1	TRB 60	50.5	60	32.5
Type 2	TRB 70	50	70	43

Cable-through CT

References

Primary	Secondary ⁽¹⁾	TCA 14		TCA 21		TCA 22		T2CA 225		
		Class 1	Reference	Class 1	Class 0.5	Reference	Class 1	Reference	Class 0.2s	Reference
40 A	5 A	1	192T 1404							
50 A	5 A	1	192T 1405							
60 A	5 A	1.5	192T 1406	1 VA		192T 2006				
75 A	5 A	1.5	192T 1407	1.5 VA		192T 2007				
80 A	5 A			1.5 VA		192T 2008				
100 A	5 A	2.5	192T 1410		1.5 VA	192T 2010	1 VA	192T 2022		
125 A	5 A	2.5	192T 1412		1.5 VA	192T 2012				
150 A	5 A	2.5	192T 1415		1.5 VA	192T 2015	1.5 VA	192T 2023	1.5 VA	192U 2215
200 A	5 A				2.5 VA	192T 2020	2.5 VA	192T 2024	2.5 VA	192U 2220
250 A	5 A				2.5 VA	192T 2016	3.75 VA	192T 2025	5 VA	192U 2225
300 A	5 A				2.5 VA	192T 2017	3.75 VA	192T 2030	5 VA	192U 2230
400 A	5 A						5 VA	192T 2034	5 VA	192U 2240
500 A	5 A						5 VA	192T 2035 (2)	10 VA	192U 2250
600 A	5 A						5 VA	192T 2036 (2)	10 VA	192U 2260

(1) Secondary 1 A: on request.

(2) Dimensions of T2CA 225

Accessories

Description of accessories	TCA 14 Reference	TCA 21 Reference	TCA 22 Reference	T2CA 225 Reference
DIN-rail mounting	192T 0006	192T 0006	192T 0007	192T 0003
Guide tube Ø 8.5 mm ⁽¹⁾		192T 0020		
Guide tube Ø 12.5 mm ⁽¹⁾		192T 0021	192T 0023	
Guide tube Ø 16.5 mm ⁽¹⁾			192T 0024	
Sealable cover				192T 0105

(1) For centralising cables within the CT aperture.

Dimensions

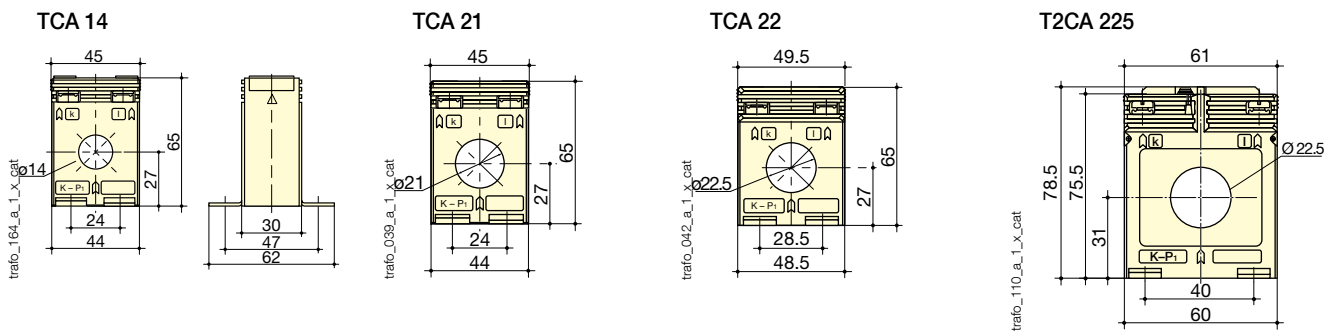

Cable-through CT	TCA 14	TCA 21	TCA 22 ⁽¹⁾	T2CA 225
Ø cable (mm)	14	21	22.5	22.5
H x W x D (mm)	65 x 45 x 30	65 x 45 x 30	65 x 49.5 x 35	78.5 x 61 x 35
DIN-rail mounting	yes	yes	yes	yes

(1) Dimensions are different for 600 A: 78.5x61x35.

Current transformers

Measurement devices

from 5 to 5000 A

Bar or cable-through CT

References

Primary	Secondary ⁽¹⁾	TCB 17-20		TCB 26-30			T2CB 26-30		TCB 28-30		
		Class 1	Reference	Class 0.5	Class 1	Reference	Class 0.2s	Reference	Class 0.5	Class 1	Reference
50 A	5 A				1 VA	192T 2305					
60 A	5 A	1 VA	192T 2106		1 VA	192T 2306					
75 A	5 A	1 VA	192T 2107		1.5 VA	192T 2307					
80 A	5 A	1.25 VA	192T 2108		1.5 VA	192T 2308				1.25 VA	192T 2408
100 A	5 A	1.5 VA	192T 2110	1.5 VA		192T 2310				1.5 VA	192T 2410
125 A	5 A	1.5 VA	192T 2112	1.5 VA		192T 2312				2.5 VA	192T 2412
150 A	5 A	2.5 VA	192T 2115	1.5 VA		192T 2315	1.5 VA	192U 2315		2.5 VA	192T 2415
160 A	5 A	2.5 VA	192T 2116								
200 A	5 A	2.5 VA	192T 2120	2.5 VA		192T 2320	2.5 VA	192U 2320	2.5 VA		192T 2420
250 A	5 A	5 VA	192T 2125	5 VA		192T 2325	2.5 VA	192U 2325	2.5 VA		192T 2425
300 A	5 A	5 VA	192T 2130	5 VA		192T 2330	5 VA	192U 2330	2.5 VA		192T 2430
400 A	5 A	5 VA	192T 2140	5 VA		192T 2340	5 VA	192U 2340	5 VA		192T 2440
500 A	5 A			5 VA		192T 2350	5 VA	192U 2350	5 VA		192T 2450
600 A	5 A			5 VA		192T 2360	5 VA	192U 2360			
750 A	5 A			5 VA		192T 2375	5 VA	192U 2375			

(1) Secondary 1 A: on request.

Primary	Secondary ⁽¹⁾	TCB 26-40		TCB 32-40			T2CB 32-40	
		Class 1	Reference	Class 0.5	Class 1	Reference	Class 0.2s	Reference
75 A	5 A				1.5 VA	192T 4007		
100 A	5 A	1.5 VA	192T 3210	1.5 VA		192T 4010		
125 A	5 A	2.5 VA	192T 3212	1.5 VA		192T 4012		
150 A	5 A	2.5 VA	192T 3215	2.5 VA		192T 4015		
160 A	5 A	2.5 VA	192T 3216					
200 A	5 A	2.5 VA	192T 3220	5 VA		192T 4020	2.5 VA	192U 4020
250 A	5 A	2.5 VA	192T 3225	5 VA		192T 4025	5 VA	192U 4025
300 A	5 A	5 VA	192T 3230	10 VA		192T 4030	5 VA	192U 4030
400 A	5 A	5 VA	192T 3240	10 VA		192T 4040	5 VA	192U 4040
500 A	5 A	5 VA	192T 3250	10 VA		192T 4050	5 VA	192U 4050
600 A	5 A	5 VA	192T 3260	10 VA		192T 4060	5 VA	192U 4060
750 A	5 A	10 VA	192T 3275	10 VA		192T 4075	5 VA	192U 4075
800 A	5 A			10 VA		192T 4080		
1000 A	5 A			10 VA		192T 4090		

(1) Secondary 1 A: on request.

Accessories

Description of accessories	TCB 17-20 Reference	TCB 26-30 Reference	TCB 26-40 Reference	TCB 32-40 Reference
DIN-rail mounting	192T 0007	192T 0003	192T 0003	192T 0005
Sealable cover		192T 0105	192T 0105	192T 0103

CT Plug-in transducer (CEA-VA)

Power supply	Output	TCB 26-30 Reference	TCB 26-40 Reference	TCB 32-40 Reference
Self-supplied	0-20 mA / 0-10 VDC	192Y 0015	192Y 0015	192Y 0035
230 VAC	0-20 mA / 0-10 VDC	192Y 0215	192Y 0215	192Y 0235
24 VDC	0-20 mA / 0-10 VDC	192Y 0115	192Y 0115	192Y 0135

CT Plug-in transducer (CEA-VA4)

Power supply	Output	TCB 26-30 Reference	TCB 26-40 Reference	TCB 32-40 Reference
230 VAC	4-20 mA / 0-10 VDC	192T 0255	192T 0255	192Y 0275
24 VDC	4-20 mA / 0-10 VDC	192Y 0155	192Y 0155	192Y 0175

References

Primary	Secondary ⁽¹⁾	TCB 44-50		TCB 44-63		T2CB 44-63	
		Class 0.5	Reference	Class 0.5	Reference	Class 0.2s	Reference
150 A	5 A	1.5 VA	192T 5015				
200 A	5 A	2.5 VA	192T 5020	1.5 VA	192T 6420		
250 A	5 A	5 VA	192T 5025	1.5 VA	192T 6425		
300 A	5 A	5 VA	192T 5030	2.5 VA	192T 6430	5 VA	192U 6430
400 A	5 A	10 VA	192T 5040	5 VA	192T 6440	5 VA	192U 6440
500 A	5 A	10 VA	192T 5050	10 VA	192T 6450	10 VA	192U 6450
600 A	5 A	10 VA	192T 5060	10 VA	192T 6460	10 VA	192U 6460
750 A	5 A	10 VA	192T 5075	10 VA	192T 6475	10 VA	192U 6475
800 A	5 A	15 VA	192T 5080	10 VA	192T 6480		
1000 A	5 A	15 VA	192T 5090	15 VA	192T 6490	10 VA	192U 6490
1200 A	5 A	15 VA	192T 5092	15 VA	192T 6492	10 VA	192U 6492
1250 A	5 A	15 VA	192T 5095	15 VA	192T 6493	10 VA	192U 6493
1500 A	5 A			15 VA	192T 6495	10 VA	192U 6495
1600 A	5 A			15 VA	192T 6494		

(1) Secondary 1 A: on request.

Primary	Secondary ⁽¹⁾	TCB 55-80		TCB 85-100		TCB 100-125	
		Class 0.5	Reference	Class 0.5	Reference	Class 0.5	Reference
400 A	5 A	2.5 VA	192T 8140				
500 A	5 A	5 VA	192T 8150				
600 A	5 A	5 VA	192T 8160				
750 A	5 A	10 VA	192T 8175	2.5 VA	192T 9675		
800 A	5 A	10 VA	192T 8180	5 VA	192T 9680		
1000 A	5 A	15 VA	192T 8190	10 VA	192T 9690	5 VA	192T 9590
1200 A	5 A	15 VA	192T 8192	10 VA	192T 9692	10 VA	192T 9592
1250 A	5 A	15 VA	192T 8193	15 VA	192T 9693	10 VA	192T 9593
1500 A	5 A	15 VA	192T 8195	15 VA	192T 9695	15 VA	192T 9595
1600 A	5 A	15 VA	192T 8194	15 VA	192T 9694		
2000 A	5 A	15 VA	192T 8196	30 VA	192T 9696	30 VA	192T 9596
2500 A	5 A			30 VA	192T 9697	30 VA	192T 9597
3000 A	5 A			30 VA	192T 9698	30 VA	192T 9598

(1) Secondary 1 A: on request.

Accessories

Description of accessories	TCB 44-50 Reference	TCB 44-63 Reference	TCB 55-80 Reference	TCB 85-100 Reference	TCB 100-125 Reference
Sealable cover	192T 0102	192T 0102	192T 0102	192T 0106	192T 0106

CT Plug-in transducer (CEA-VA)

Power supply	Output	TCB 44-50 Reference	TCB 44-63 Reference	TCB 55-80 Reference
Self-supplied	0-20 mA / 0-10 VDC		192Y 0045	192Y 0045
230 VAC	0-20 mA / 0-10 VDC		192Y 0245	192Y 0245
24 VDC	0-20 mA / 0-10 VDC		192Y 0145	192Y 0145

CT Plug-in transducer (CEA-VA4)

Input	Output	TCB 44-50 Reference	TCB 44-63 Reference	TCB 55-80 Reference
230 VAC	4-20 mA / 0-10 VDC		192Y 0285	192Y 0285
24 VDC	4-20 mA / 0-10 VDC		192Y 0185	192Y 0185

Current transformers

Measurement devices

from 5 to 5000 A

Bar or cable-through CT (continued)

Dimensions

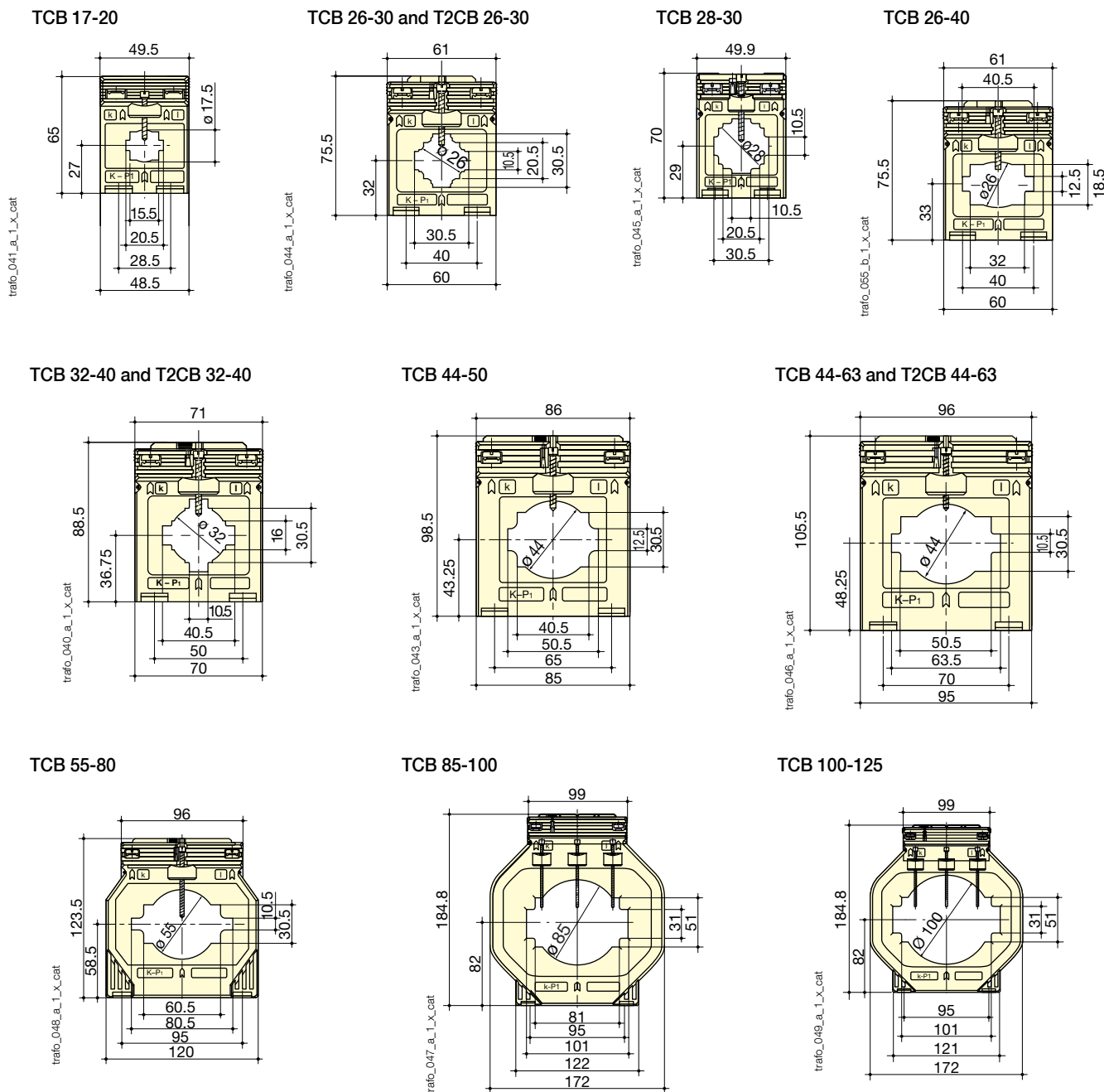

Bar or cable-through CT	TCB 17-20	TCB 26-30	T2CB 26-30	TCB 26-40	TCB 28-30	TCB 32-40	T2CB 32-40
Bar (mm)	20 x 5 (x 1)	30 x 10 (x 1) / 20 x 10 (x 1...2)	30 x 10 (x 1) / 20 x 10 (x 1...2)	40 x 12 (x 1) / 32 x 18 (x 1)	30 x 10 (x 1)	40 x 10 (x 1) / 30 x 5 (x 1...2)	40 x 10 (x 1) / 30 x 5 (x 1...2)
ϕ cable (mm)	17.5	26	26	26	28	32	32
H x W x D (mm)	65 x 49.5 x 50	75.5 x 61 x 48	75.5 x 61 x 48	75.5 x 61 x 48	70 x 49.9 x 68	88.5 x 71 x 58	88.5 x 71 x 58
DIN-rail mounting	yes	yes	yes	yes		yes	yes

Bar or cable-through CT	TCB 44-50	TCB 44-63	T2CB 44-63	TCB 55-80	TCB 85-100	TCB 100-125
Bar (mm)	50 x 12 (x 1) / 40 x 10 (x 1...2)	63 x 10 (x 1) / 50 x 10 (x 1...2)	63 x 10 (x 1) / 50 x 10 (x 1...2)	80 x 10 (x 1) / 60 x 30 (x 1) / 60 x 10 (x 1...2)	100 x 10 (x 1...2) / 80 x 10 (x 1...3)	123 x 30 (x 1) / 100 x 10 (x 1...3)
ϕ cable (mm)	44	44	44	55	85	100
H x W x D (mm)	98.5 x 86 x 58	105.5 x 96 x 58	105.5 x 96 x 58	123.5 x 120 x 58	184.5 x 172 x 52	184.5 x 172 x 52

Associated transducers

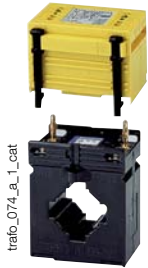

trafo_074_a_1_cat



Transducer to be associated with adapted current transformers:

- Class 0.5.
- Input: 1 or 5 A
- Output:
 - 0-20 mA, 0-10 V (model CEA-VA),
 - 4-20 mA, 0-10 V (model CEA-VA4),
- Self-supplied or auxiliary power supply 24 VDC or 230 VAC.
- 3 sizes according to the CT: type 1, 2 or 3.

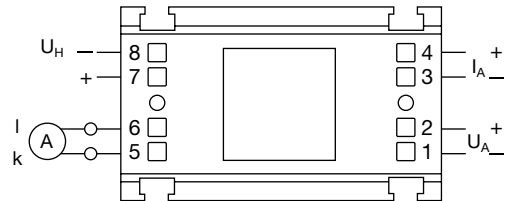

trafo_060_a_1_x_cat

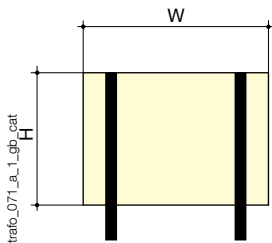

trafo_071_a_1_gb_cat

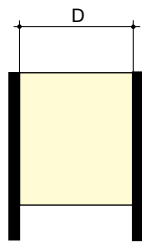

Dimensions (mm)

Converter	For CT	Height (mm)	Width (mm)	Depth (mm)
Type 1	TCB 26-30	50.5	60	32.5
Type 1	TCB 26-40	50.5	60	32.5
Type 2	TCB 32-40	50	70	43
Type 3	TCB 44-63	50.5	95	43
Type 3	TCB 55-80	50.5	95	43

Current transformers

Measurement devices

from 5 to 5000 A

Bar-through CT

References

Primary	Secondary	TBA 60			TBA 80		TBA 100		T2BA 100	
		Class 0.5	Class 1	Reference	Class 0.5	Reference	Class 0.5	Reference	Class 0.2s	Reference
200 A	5 A		2.5 VA	192T 7020						
250 A	5 A	2.5 VA		192T 7025						
300 A	5 A	2.5 VA		192T 7030	2.5 VA	192T 7530				
400 A	5 A	5 VA		192T 7040	5 VA	192T 7540				
500 A	5 A	5 VA		192T 7050	5 VA	192T 7550				
600 A	5 A	10 VA		192T 7060	5 VA	192T 7560	5 VA	192T 8060		
750 A	5 A	10 VA		192T 7075	5 VA	192T 7575	5 VA	192T 8075		
800 A	5 A	10 VA		192T 7080	10 VA	192T 7580	5 VA	192T 8080		
1000 A	5 A	15 VA		192T 7090	15 VA	192T 7590	5 VA	192T 8090		
1200 A	5 A	15 VA		192T 7092	15 VA	192T 7592	10 VA	192T 8092	5 VA	192U 8092
1250 A	5 A	15 VA		192T 7093	15 VA	192T 7593	10 VA	192T 8093	5 VA	192U 8093
1500 A	5 A	15 VA		192T 7095	15 VA	192T 7595	15 VA	192T 8095	5 VA	192U 8095
1600 A	5 A	15 VA		192T 7094	15 VA	192T 7594	15 VA	192T 8094		
2000 A	5 A				15 VA	192T 7596	15 VA	192T 8096	5 VA	192U 8096
2500 A	5 A						30 VA	192T 8097	10 VA	192U 8097
3000 A	5 A						30 VA	192T 8098 (1)	10 VA	192U 8098
4000 A	5 A						30 VA	192T 8099 (1)		

(1) Dimensions are different for TBA 100 with 3000 and 4000 A primary.

Primary	Secondary	TBA 103		T2BA 103		TBA 127		T2BA 127	
		Class 0.5	Reference	Class 0.2s	Reference	Class 0.5	Reference	Class 0.2s	Reference
400 A	5 A	2.5 VA	192T 9340			2.5 VA	192T 9740		
500 A	5 A	2.5 VA	192T 9350			2.5 VA	192T 9750		
600 A	5 A	2.5 VA	192T 9360			2.5 VA	192T 9760		
750 A	5 A	2.5 VA	192T 9375			2.5 VA	192T 9775		
800 A	5 A	5 VA	192T 9380			5 VA	192T 9780		
1000 A	5 A	10 VA	192T 9390	5 VA	192U 9390	10 VA	192T 9790		
1200 A	5 A	10 VA	192T 9392	5 VA	192U 9392	10 VA	192T 9792	5 VA	192U 9792
1250 A	5 A	10 VA	192T 9393	5 VA	192U 9393	10 VA	192T 9793	5 VA	192U 9793
1500 A	5 A	15 VA	192T 9395	5 VA	192U 9395	15 VA	192T 9795	5 VA	192U 9795
1600 A	5 A	10 VA	192T 9394			15 VA	192T 9794		
2000 A	5 A	15 VA	192T 9396			15 VA	192T 9796	5 VA	192U 9796
2500 A	5 A					15 VA	192T 9797		
3000 A	5 A					25 VA	182T 9798 (1)		
4000 A	5 A					30 VA	182T 9799 (1)		

(1) Replacement model TRA 127 for this rating.

Accessories

Description of accessories	TBA 60 Reference	TBA 80 Reference	TBA 100 Reference	T2BA 100 Reference	TBA 103 Reference	T2BA 103 Reference	TBA 127 Reference	T2BA 127 Reference
Sealable cover	192T 0102		192T 0102	192T 0102			192T 0102	192T 0102

CT Plug-in transducer (CEA-VA)

Power supply	Output	TBA 100 Reference
Self-supplied	0-20 mA / 0-10 VDC	192Y 0045
230 VAC	0-20 mA / 0-10 VDC	192Y 0245
24 VDC	0-20 mA / 0-10 VDC	192Y 0145

CT Plug-in transducer (CEA-VA4)

Power supply	Output	TBA 100 Reference
230 VAC	4-20 mA / 0-10 VDC	192Y 0285
24 VDC	4-20 mA / 0-10 VDC	192Y 0185

Dimensions

TBA 60

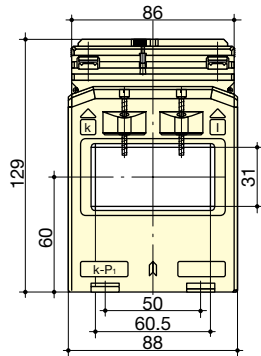

trafo_050_a_1_x_cat

TBA 80
300 to 2000 A

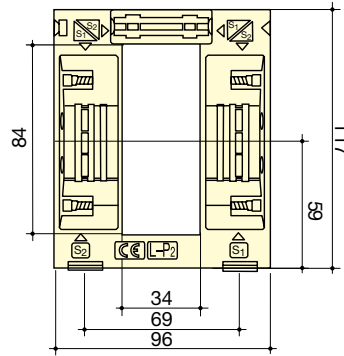

trafo_059_a_1_x_cat

TBA 100 600 to 2500 A⁽¹⁾
T2BA 100 1200 to 3000 A

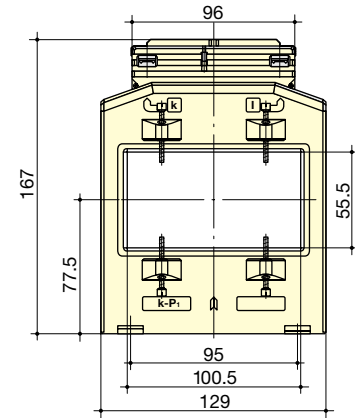

trafo_082_a_1_x_cat

(1) TBA 100, 3000 and 4000 A: 214 x 129 x 78 mm.

TBA 103 and T2BA 103

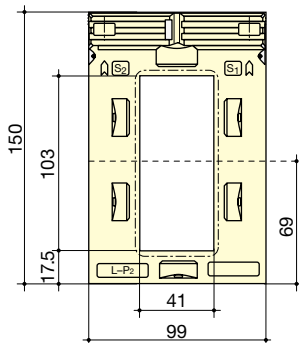

trafo_054_a_1_x_cat

TBA 127 and T2BA 127

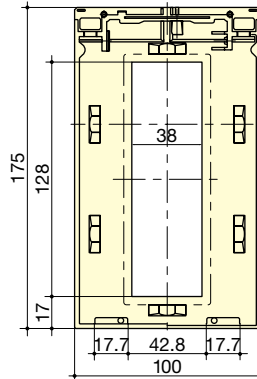

trafo_052_a_1_x_cat

Bar-through CT	TBA 60	TBA 80	TBA 100	T2BA 100	TBA 103	T2BA 103	TBA 127	T2BA 127
Bar (mm)	60 x 30	84 x 34	100 x 55	100 x 55	103 x 41	103 x 41	128 x 38	128 x 38
H x W x D (mm)	129 x 88 x 78	117 x 96 x 68	167 x 129 x 78 ⁽¹⁾	167 x 129 x 78	150 x 99 x 58	150 x 99 x 58	175 x 100 x 55	175 x 100 x 55

(1) TBA 100, 3000 and 4000 A: 214 x 129 x 78 mm.

Current transformers

Measurement devices

from 5 to 5000 A

Three-phase bar or cable-through CT

References

Primary	Secondary ⁽¹⁾	TCB3 18-20		TCB3 22-30	
		Class 1	Reference	Class 1	Reference
3 x 100 A	3 x 5 A	1 VA	192T 3310		
3 x 150 A	3 x 5 A	1.25 VA	192T 3315		
3 x 200 A	3 x 5 A	1.5 VA	192T 3320		
3 x 250 A	3 x 5 A	2.5 VA	192T 3325	2.5 VA	192T 3425
3 x 300 A	3 x 5 A			3.75 VA	192T 3430
3 x 400 A	3 x 5 A			5 VA	192T 3440
3 x 500 A	3 x 5 A			5 VA	192T 3450
3 x 600 A	3 x 5 A			5 VA	192T 3460

(1) Secondary 1 A: on request.

Dimensions

TCB3 18-20

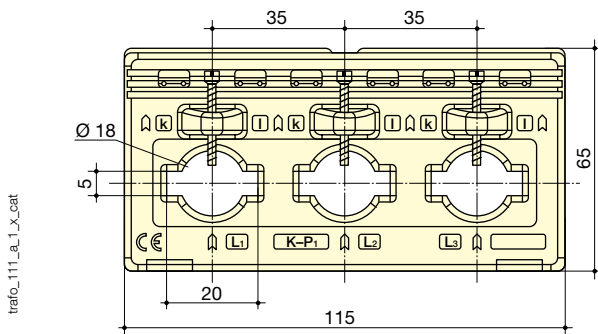

TCB3 22-30

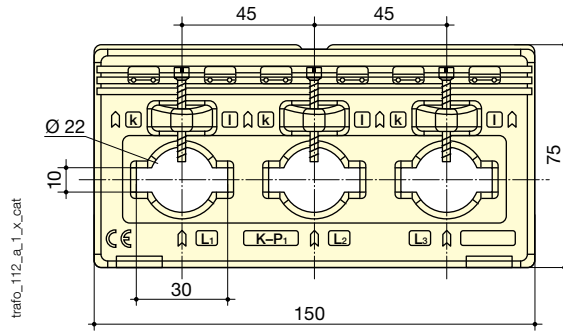

Three-phase bar or cable-through CT	TCB3 18-20	TCB3 22-30
Ø cable (mm)	18	22
Bar-through	20 x 5	30 x 10
H x W x D (mm)	115 x 65 x 37	150 x 75 x 37
DIN-rail mounting	no	no

References

Primary	Secondary ⁽¹⁾	TCA 13 – 3P	
		Class 1	Reference
3 x 50 A	5 A	1 VA	192T 1905
3 x 60 A	5 A	1.25 VA	192T 1906
3 x 75 A	5 A	1.5 VA	192T 1907
3 x 80 A	5 A	1.5 VA	192T 1908
3 x 100 A	5 A	2.5 VA	192T 1910
3 x 125 A	5 A	2.5 VA	192T 1912
3 x 150 A	5 A	2.5 VA	192T 1915
3 x 160 A	5 A	2.5 VA	192T 1916

(1) Secondary 1 A: on request.

Dimensions

TCA 13 – 3P

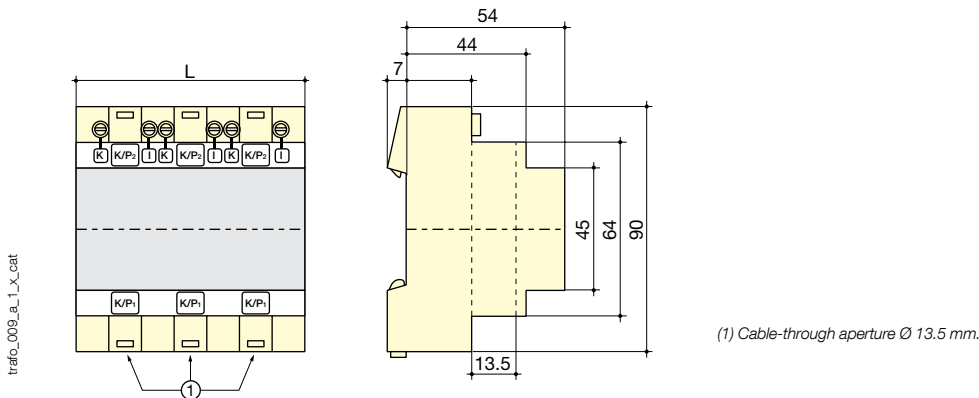

Number of modules	Front degree of protection	Terminal degree of protection	L (mm)	Mounting
6	IP65	IP20	105	35 mm DIN-rail

Current transformers

Measurement devices

from 5 to 5000 A

Split-core CT

References

Primary	Secondary	TO 23			TO 58			TO 812			TO 816	
		Class 1	Class 3	Reference	Class 0.5	Class 1	Reference	Class 0.5	Class 1	Reference	Class 0.5	Reference
100 A	5 A		1.25 VA	192T 4601								
150 A	5 A		1.5 VA	192T 4602								
200 A	5 A		2.5 VA	192T 4603								
250 A	5 A	1.5 VA		192T 4604		1.5 VA	192T 4625		1.5 VA	192T 4725		
300 A	5 A	3.75 VA		192T 4605		2.5 VA	192T 4630		2.5 VA	192T 4730		
400 A	5 A	5 VA		192T 4606	1 VA		192T 4640		2.5 VA	192T 4740		
500 A	5 A				2.5 VA		192T 4650	2.5 VA		192T 4750		
600 A	5 A				2.5 VA		192T 4660	2.5 VA		192T 4760		
750 A	5 A				2.5 VA		192T 4675	2.5 VA		192T 4775		
800 A	5 A				2.5 VA		192T 4680	2.5 VA		192T 4780		
1000 A	5 A				5 VA		192T 4610	5 VA		192T 4710	10 VA	192T 4810
1250 A	5 A							7.5 VA		192T 4712	10 VA	192T 4812
1500 A	5 A							7.5 VA		192T 4715	10 VA	192T 4815
1600 A	5 A										10 VA	192T 4814
2000 A	5 A										10 VA	192T 4820
2500 A	5 A										10 VA	192T 4825
3000 A	5 A										15 VA	192T 4830
4000 A	5 A										15 VA	192T 4840
5000 A	5 A										15 VA	192T 4850

Dimensions

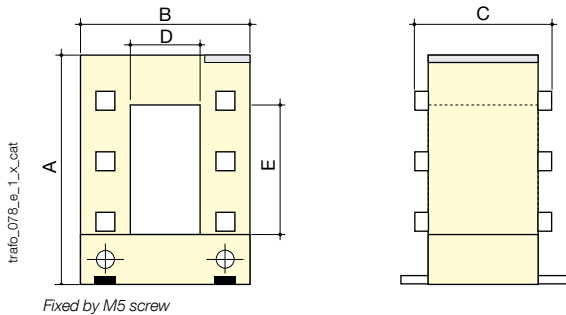

Dimensions (mm)

Type	A (mm)	B (mm)	C (mm)	D (mm)	E (mm)
TO 23	106	93	58	23	33
TO 58	158	125	58	55	85
TO 812	198	155	58	85	125
TO 816	243	195	79	85	165

Split-core CT	TO 23	TO 58	TO 812	TO 816
H x W x D (mm)	106 x 93 x 58	158 x 125 x 58	198 x 155 x 58	243 x 195 x 75

Summation CT

Reference

Primary	Secondary	BSA 02 Reference	BSA 03 Reference	BSA 04 Reference
5 + 5/5 A	5 A	192T 0802		
5A + 5+ 5/5	5 A		192T 0803	
5 + 5 + 5 + 5/5 A	5 A			192T 0904

Dimensions

BSA 02 and BSA 03

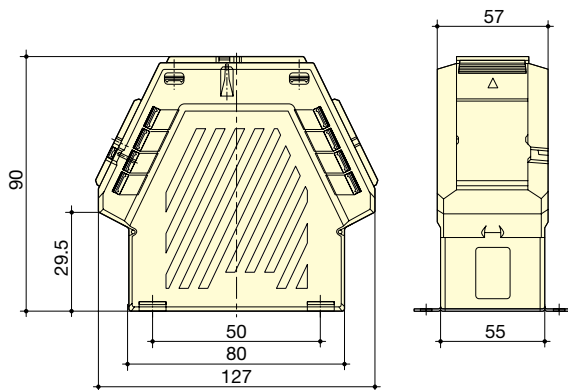

BSA 04

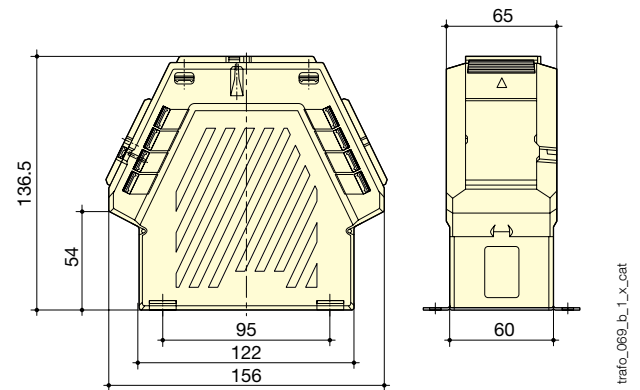

Summation CT	BSA 02	BSA 03	BSA 04
H x W x D (mm)	90 x 127 x 57	90 x 127 x 57	136.5 x 156 x 65
DIN-rail mounting	no	no	no



Measurement shunts

Measurement devices

Current transformers

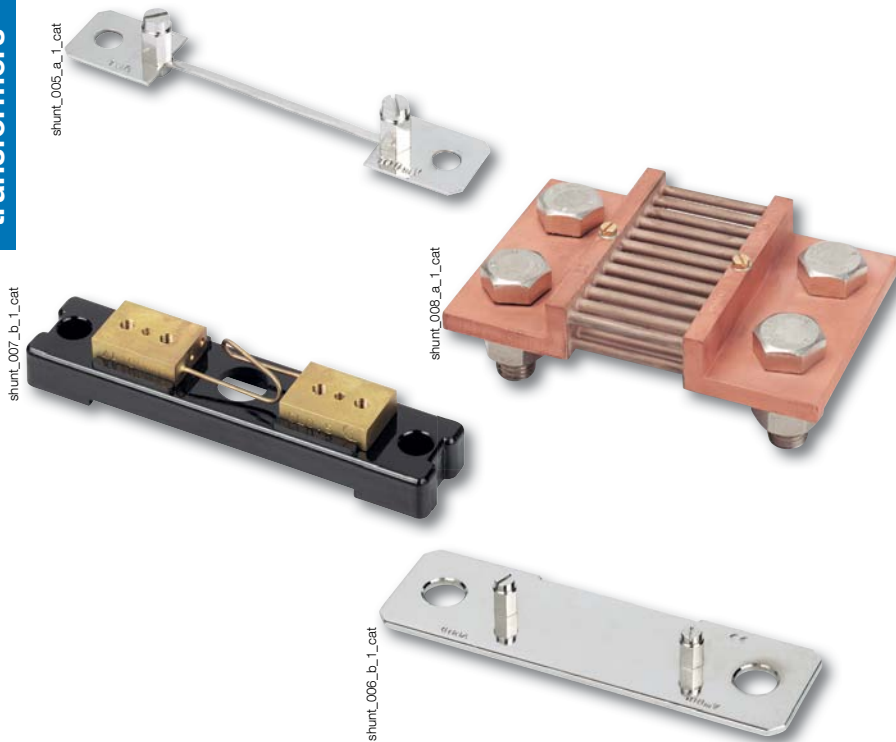

Composition of the range

> 20 ratings available from 1 to 6000 A, with 100 mV output

Function

SOCOMEc shunts provide indirect measurement of direct current by creating a standardised voltage drop.

Characteristics

- Voltage drop: 100 mV for nominal rating.
- Accuracy class: 0,5.
- Permanent overload: 1.2 In.
- 10 In / 5s rating \leq 500 A
5 In / 5s rating 600 to 1500 A
2 In / 5s rating \geq 2500 A.

References

Rating ⁽¹⁾	Secondary voltage drop	DIN series Reference
1 A	100 mV	192S 2101
4 A	100 mV	192S 2104
6 A	100 mV	192S 2106
10 A	100 mV	192S 2110
15 A	100 mV	192S 2112
25 A	100 mV	192S 2114
40 A	100 mV	192S 2116
60 A	100 mV	192S 2118
100 A	100 mV	192S 2120
150 A	100 mV	192S 2125
200 A	100 mV	192S 2220
250 A	100 mV	192S 2235
300 A	100 mV	192S 2230
400 A	100 mV	192S 2240
600 A	100 mV	192S 2250
1000 A	100 mV	192S 2255
1500 A	100 mV	192S 2260
2500 A	100 mV	192S 2165
4000 A	100 mV	192S 2170
6000 A	100 mV	192S 2175

(1) Other rating: please consult us.



Other products

Measurement devices

PTI: CT automatic short-circuiter



Use

This device provides automatic short-circuiting of the CT: if the measuring circuit is opened.

Conformity to standards

- > NF C 15-100 articles 473.1.4-556.3
- > GAM EG 13.C (military standard)

Other regulations

- > Decree n° 88-1056 from 14-11-88: protection of workers
- > Complies with the Mines and Quarries decree n° 91-986

References

Rating (A)	Trigger voltages	Operating frequency	Max. differential voltage	Reference
5	21 VAC	45 ... 400 Hz	600 VAC	4990 0521
5	25 VAC	45 ... 400 Hz	600 VAC	4990 0525(1)

(1) DCN approved (French State Naval Construction Company).

Characteristics

Case degree of protection	IP55
Terminal protection degree	IP20
Connection cross-section	2.5 mm ²
Weight	82 g

Rating (A)	D1	E	F	H	H1	I	L
5	4.2	47	9.6	32	44	41	34.7

Dimensions

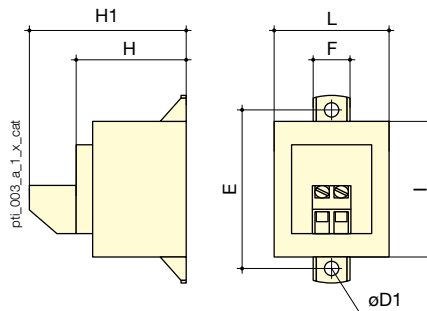

Sensor PT100 - screw type

- Element sensitivity as per standard IEC 751 class A.
- 4 wire mounting.
- 3 meter length output of Teflon isolated cable.
- Tolerance class A:
 - Accuracy at -50 °C: ± 0.14 °C,
 - Accuracy at 0 °C: ± 0.13 °C,
 - Accuracy at +50 °C: ± 0.25 °C,
 - Accuracy at +100 °C: ± 0.26 °C,
 - Accuracy at +150 °C: ± 0.33 °C.

References

Products	Reference
Temperature sensor PT100 - M6 screw type	4825 0208
Temperature sensor PT100 - eyelet type	4825 0209

Dimensions

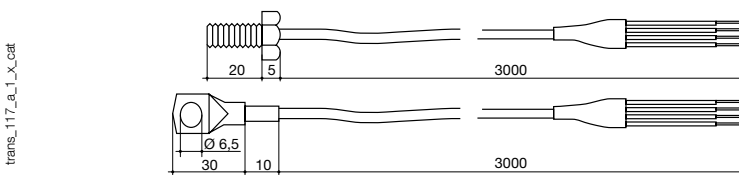

Transformer with integrated converter (CTA-VA)



Compact measurement converter with cable-through transformer (Ø27 mm) or bar transformer (40 x 10 mm).

- Input:
 - Direct Connection 0 to 10 A,
 - CT primary of 40 to 800 A (self-supplied)
 - CT primary of 15 to 800 A (auxiliary supply)
- Output:
 - 0-20 mA, 0-10 V (type CTA-VA)
 - 4-20 mA and 0-10 V (type CTA-VA4).
- Self-supplied or auxiliary power supply 24 VDC or 230 VAC.
- Dimension: 135 x 80 x 50 mm.

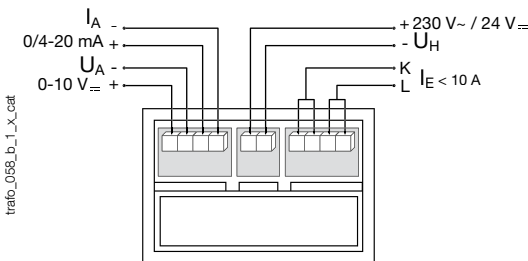

References

Primary	0-20 mA / 0-10 VDC Self supplied	0-20 mA / 0-10 VDC 230 VAC	0-20 mA / 0-10 VDC 24 VDC	4-20 mA / 0-10 VDC 230 VAC	4-20 mA / 0-10 VDC 24 VDC
Reference	Reference	Reference	Reference	Reference	Reference
1 A	192Y 0401	192Y 0501	192Y 0801	192Y 0601	on request
5 A	192Y 0402	192Y 0502	192Y 0802	192Y 0602	192Y 0902
10 A		192Y 0503	192Y 0803	192Y 0603	on request
15 A		192Y 0504	192Y 0804	192Y 0604	192Y 0904
20 A		192Y 0505	on request	192Y 0605	192Y 0905
25 A		on request	on request	192Y 0606	192Y 0906
30 A		192Y 0507	192Y 0807	192Y 0607	192Y 0907
40 A	192Y 0408	192Y 0508	on request	192Y 0608	192Y 0908
50 A	192Y 0409	192Y 0509	192Y 0809	192Y 0609	192Y 0909
60 A	192Y 0410	192Y 0510	on request	192Y 0610	192Y 0910
75 A	192Y 0411	192Y 0511	192Y 0811	192Y 0611	192Y 0911
100 A	192Y 0412	192Y 0512	192Y 0812	192Y 0612	192Y 0912
150 A	192Y 0415	on request	192Y 0815	192Y 0615	on request
200 A	192Y 0420	192Y 0520	on request	192Y 0620	on request
250 A	192Y 0425	192Y 0525	192Y 0825	192Y 0625	192Y 0925
300 A	192Y 0430	192Y 0530	192Y 0830	192Y 0630	192Y 0930
400 A	192Y 0440	192Y 0540	192Y 0840	192Y 0640	192Y 0940
500 A	192Y 0450	192Y 0550	192Y 0850	192Y 0650	on request
600 A	192Y 0460	192Y 0560	on request	on request	192Y 0960
750 A	192Y 0475	on request	192Y 0875	192Y 0675	192Y 0975
800 A	192Y 0480	192Y 0580	192Y 0880	192Y 0680	192Y 0980

Voltage transformer BTV 25



Applications

Measurement and conversion of the input value read at the primary of a transformer in a directly proportional voltage signal.
BTV 25 products are voltage transformers.

Recommendation

Voltage transformers are used specifically for supplying measurement equipment, therefore it is not recommended to connect other components which could affect accuracy. This is due to the effect of the phase shift error. If the consumption is greater than 25 VA, another transformer must be added.

Characteristics

Accuracy class	1 %
Dielectric quality	3 kV for 1 min.
Operating frequency	50 - 60 Hz
Permanent overload	1.2 U_n

Connection

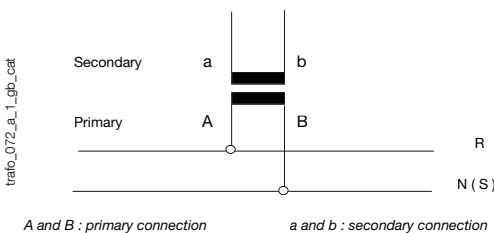

References

Primary	Secondary	Power	Reference
230 VAC	100 VAC	25 VA	192M 2020
400 VAC	100 VAC	25 VA	192M 2030
440 VAC	100 VAC	25 VA	192M 2044
500 VAC	100 VAC	25 VA	192M 2050
600 VAC	100 VAC	25 VA	192M 2060
660 VAC	100 VAC	25 VA	192M 2066
800 VAC	100 VAC	25 VA	Please consult us

Dimensions

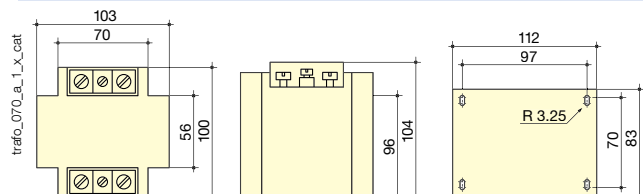



Selection guide

Branch Circuit Monitoring System



DIRIS BCMS 720

Metering and measurement for data centres

Which communication protocol?





New or existing installation?

Products and associated equipment	New installation	
Products		
DIRIS BCMS 720 with RS485 Modbus communication	•	
DIRIS BCMS 720 with RS485 MODBUS communication and Ethernet SNMP	•	
Additional equipment needed		
CT strip with 6 CTs	•	
CT strip with 9 CTs	•	
Split-core CTs (63 A) for 18 branch circuits		
Cable harness for 18 split-core CTs		
	CT strips with 6 CTs Quantity to be ordered	CT strips with 9 CTs Quantity to be ordered
		
	<i>p. 118</i>	<i>p. 118</i>
Number of distribution circuits		
12	2	
18		2
24	4	
30	2	2
36		4
42	4	2
48	2	4
54		6
60	4	4
66	2	6
72		8
Accessories		
DIN-rail mounting kit for DIRIS BCMS 720	•	
Power supply kit 230 VAC / 24 VAC	•	
Measuring kit for 400 A input circuits	•	
CT strip repair kit	•	



How many
branch circuits?

Existing installations	
	•
	•
	•
	•

Cable harness and measurement acquisition card Quantity to be ordered	Split-core CTs for 18 branch circuits Quantity to be ordered
	
<i>p. 118</i>	<i>p. 118</i>
2	1
2	1
2	2
2	2
2	2
4	3
4	3
4	3
4	4
4	4
4	4

	•
	•
	•



DIRIS BCMS 720

Branch Circuit Monitoring System up to 72 branch circuits

Metering and measurement for data centres

new



diris-bcms_003_a_1_cat

diris-bcms_001_b_1_cat

diris-bcms_002_a_1_cat

Function

Energy efficiency is becoming a major concern for the owners and operators of data centres. The DIRIS BCMS 720 is a real asset in obtaining energy savings thanks to its ability to monitor currents, power and energy on 72 single-phase distribution circuits in PDU type electrical switchboards⁽¹⁾.

With a Modbus or SNMP communication, this device can be easily connected to any Power Monitoring Software (EMS/PMS). It can also generate event alarms in order to improve the availability of the data centre.

(1) PDU: Power Distribution Unit

Advantages

Compact and cost effective

Thanks to its compact dimensions, the DIRIS BCMS 720 can be easily integrated into PDU or RPP type end of line switchboards. It also reduces the costs of measuring points, as a single device can supervise up to 72 single-phase distribution circuits and 10 additional main incoming circuits.

Easy installation

The DIRIS BCMS 720 is perfectly adapted to any new or existing installation. The device can be easily back plate or DIN-rail mounted. Setting is also facilitated thanks to the EASY CONFIG software.

Safe and robust

All components are protected by a durable casing to avoid:

- direct electrical contact,
- any possible mechanical damage during transportation, installation and handling of the device.

Performance

The accuracy of the global measurement chain (DIRIS BCMS 720 + CTs) is 0.5%. Real-time supervision enables the detection and reporting of operating faults, for example the detection of zero current on a branch circuit.

Improved communication

With RS485 MODBUS communication and/or Ethernet SNMP, the DIRIS BCMS 720 can be easily connected to Power Monitoring systems (EMS/PMS). When connected through a DIRIS A40's Ethernet module, the Webserver enables remote viewing of the measurements and status of the DIRIS BCMS 720 without the need for additional software.

The solution for

- > Data centres
- > Shopping centres
- > Offices



Strong points

- > Compact and cost effective
- > Easy installation
- > Safe and robust
- > Performance
- > Improved communication

Conformity to standards

- > IEC 60950-1



Product

DIRIS BCMS 720 Multifunction Meter

diris-bcms_001_b_1_cat



The DIRIS BCMS 720 is a measurement reporting device.

Two versions are available:

- one with RS 485 MODBUS communication,
- one with RS 485 MODBUS communication and Ethernet SNMP.

The device requires a 24V AC/DC power source.

Accessories such as a DIN-rail mounting kit or a 230V/24V power supply kit can also be provided.

Additional equipment needed

CT strips with 6 or 9 CTs

diris-bcms_001_b_1_cat



CT strips with 6 or 9 CTs (63A CTs at a pitch of 18mm) are available for new installations. In order to suit the number of distribution circuits of an installation, the total number of current transformers can easily be adapted through a combination of these two CT strips.

For the right solutions, please see page

Cable harness and split-core CTs

diris-bcms_009_a_1_cat diris-bcms_014_a_1_cat



The cable harness and plug and play split-core CT kits are perfectly adapted for easy installation on existing sites.

Accessories

CT strip repair kit

diris-bcms_005_a_1_cat

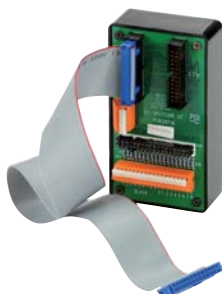

During installation and connection of the panel it is possible that damage may occur to a CT on a 6 or 9 CT strip. This kit enables any damaged CT to be replaced, avoiding the need to replace the entire CT strip. Any CT can be replaced without disconnecting cables or shutting down the installation.

Single input measuring kit

diris-bcms_012_a_1_cat



This kit comprises a connection harness and five split-core CTs. It is designed to measure the three-phase main input circuit of the electrical switchboard. The DIRIS BCMS 720 can include up to two measuring kits for two individual input circuits.

DIRIS BCMS 720

Branch Circuit Monitoring System
up to 72 branch circuits

Device for new installations

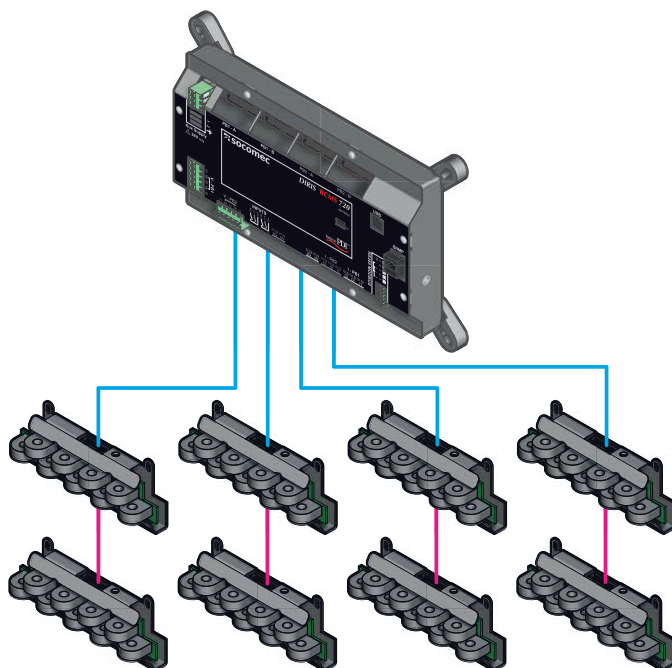

diris-bcms_019_a

Number of distribution circuits	12	18	24	30	36	42	48	54	60	66	72	Reference
	Quantity to be ordered											
CT strips with 6 CTs	2		4	2		4	2		4	2		4827 0106
CT strips with 9 CTs		2		2	4	2	4	6	4	6	8	4827 0109

Device for existing installations

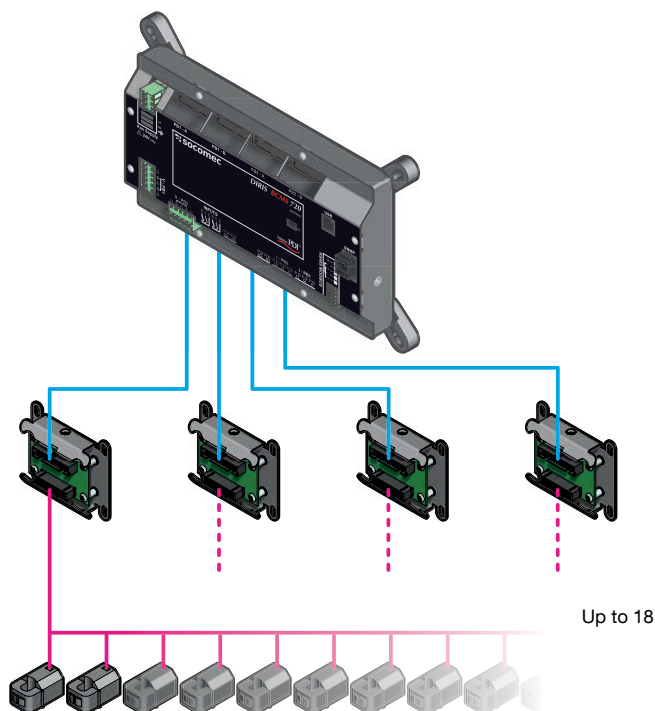

diris-bcms_020_a

Split-core CTs for 18 branch circuits (plug and play CT)	12	18	24	30	36	42	48	54	60	66	72	Reference
	Quantity to be ordered											
Cable harness for the connection of up to 18 split-core CTs			2						4			4827 2001
Split-core CTs for 18 branch circuits (plug and play CT)				1		2			3		4	4827 2003

Technical data

Products and associated equipment		SNMP communication	
Admissible voltage between phase and neutral	0 ... 300 VAC	Link	Ethernet
Frequency	48 ... 62 Hz	Protocol	SNMP
Input current at 20 °C	0 ... 400 A	Speed	10/100 Mbps
Input current at 40 °C	0 ... 250 A	Digital inputs	
Rated output current	63 A	Number of inputs	4
Permanent overload output current	75 A	Power supply	Self-supplied
Accuracy of measurements		Auxiliary power supply	
Voltage	0.3%	AC voltage	24 VAC ± 20%
Frequency	0.1%	DC voltage	24 VDC ± 10%
Output current	0.2%	Consumption	150 mA
Active Power	0.5%	Operating conditions	
Reactive Power	0.6%	Operating temperature	0-40 °C
Apparent Power	0.5%	Maximum humidity	95%
Power factor	1.0%	Maximum altitude	3000 m
Active energy	0.5%	Dimensions (W x H x D)	
MODBUS communication		DIRIS BCMS 720	240 x 145 x 39 mm
Link	RS485	CT strips with 6 CTs	126 x 74 x 41 mm
Protocol	MODBUS RTU	CT strips with 9 CTs	180 x 74 x 41 mm
Speed	9600 bds	Measurement acquisition card	85 x 74 x 23 mm

References

Product	Reference
DIRIS BCMS 720 with RS485 MODBUS communication	4827 0001
DIRIS BCMS 720 with RS485 MODBUS communication + SNMP Ethernet	4827 0002
Additional equipment needed	
CT strip with 6 CTs	4827 0106
CT strip with 9 CTs	4827 0109
Cable harness for 18 split-core CTs	4827 2001
Split-core CTs (63 A) for 18 branch circuits	4827 2003
Accessories	
Measuring kit for 400 A input circuits	4827 3000
CT strip repair kit	4827 0100
DIN-rail mounting kit for DIRIS BCMS 720	4827 0052
Power supply kit 230 VAC/24 VAC	4827 0051

Zoom



Think about it

DIRIS A multifunction measurement units

DIRIS A are panel mounted measurement units which ensure the user has access to all the measurements required for successfully carrying out energy efficiency projects and ensuring the electrical distribution is monitored. All this information can be analysed remotely using the VERTELIS software solution. Please see the DIRIS A pages for more information.

DIRIS N Network analysers

DIRIS N are multifunction network analysers designed for in-depth analysis of electrical networks. They ensure that the power quality level complies with standard EN 50160. They store the events relating to any fault or interference on the electrical network.



Other electrical measurement devices

Measurement devices

Transducers



They provide conversion of an AC electrical value (A, V, Hz, Cos phi, W, Var) into a DC signal, with standardised current or voltage.

They are available in surface-mount casings (CS range).

These devices are designed for DIN rail or back plate mounting.

Type CS transducers are available in two sizes:

- 75 mm for current, voltage and frequency converters,
- 150 mm for power or three-phase converters.

Consult us.

Modular transducers



Available in:

- 3-DIN module housings (52.5 mm) for current, voltage and frequency converters,
- 6-DIN module housings (105 mm) for current (output 4-20 mA), voltage (output 4-20 mA) converters,
- 9-DIN module housings (157.5 mm) for power or three-phase converters.

Consult us.

Analogue meters



SOCOME C ferromagnetic ammeters and voltmeters measure the AC current/voltage of any electrical circuit. SOCOMEC vibrating reed or needle type frequency meters have a converter either integrated or in a separate casing and measure the frequency of any electrical circuit.

The wattmeters, varmeters and phase-meters consist of an analogue meter and a separate converter. They are available in 3 types of casing: Rotex round barrel model in 72 or 96, in a DIN 48 to 144 body or a modular casing (3 modules).

With pointer deflections of 90° and 240°, they can be flush-mounted into cubicles, enclosures or other equipment.

Consult us.

Selector switches



Voltmeter and ammeter switches that allow phase selection on a three-phase circuit for voltage and current measurement.

They are available in three different casings:

- for screw mounting,
- with a central \varnothing 22 mm mounting,
- for DIN rail mounting.

Consult us.

Digital meters



They measure all types of electrical values (A, V, Hz, Cos phi, P, Q...).

The range:

- 2 different types of casing: rectangular or square:
 - 2 sizes of rectangular casing,
 - 2 sizes of square casing.
- direct measurement or connection to a current or voltage transformer,
- 2000-point (3.5 digits) or 20000-point (4.5 digits) display,
- possibility of having 2 or 3 different types of measurement in the same square casing (AAA-VVV-AVF...),
- multi-indicator version,
- RMS-value.

Consult us.

Hour counters



Often combined with analogue meters in an electrical panel, hour counters count the total operating time of machines or electrical equipment.

Consult us.



DIRIS G

Wireless and cabled RS485 to Ethernet communication gateways

Communication gateways

new



Configuration with EasyConfig, see page 142.

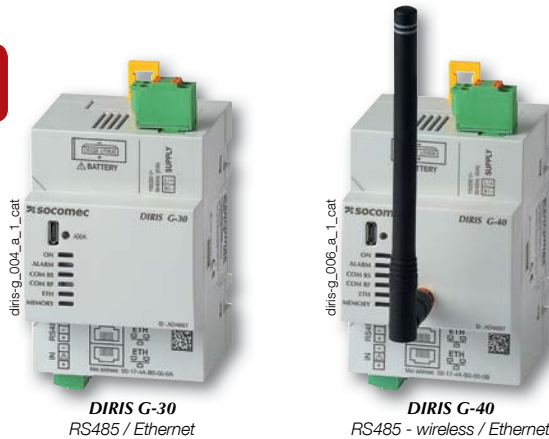

The solution for

- > Industry
- > Building
- > Infrastructure
- > Local authority



Strong points

- > WEBVIEW embedded web server
- > Plug & Play
- > Scalable

Conformity to standards

- > IEC 61010



- > ISO 14025



- > UL



Function

With **DIRIS G** communication gateways, all information from metering and measurement devices communicating wirelessly or via the RS485 bus are centralised in a single device and then made available on the Ethernet network via Modbus TCP.

The gateway has an embedded WEBVIEW web server, allowing real time monitoring of electrical values and analysis of consumption data. The user can be alerted of any alarms via email.

Advantages

WEBVIEW embedded web server⁽¹⁾

DIRIS G gateways include an embedded web server. Two versions are available:

- Power Monitoring:
 - Real time measurements and alarms
- Power & Energy Monitoring:
 - Real time measurements and alarms,
 - Historical of measurements and analysis of consumptions.
- DIRIS D-90 touch-screen tablet can be fitted on the panel door to display WEBVIEW pages.

(1) See page 138.

Plug & Play

Connected metering and measurement devices are automatically addressed and detected by the DIRIS G gateway.

DIRIS G gateways provide:

- Automatic clock synchronisation (SNTP) with battery recording.
- Synchronisation of connected devices.
- Warning messages in case of alarms (e-mail SMTP).
- Automatic recording and storage of measurements and consumption data.
- Automatic display of tariff changes.

Scalable

Several optional modules are available:

- Digital inputs/outputs.
- Analogue inputs/outputs.
- Temperature inputs.

Selection guide

	Gateway	DIRIS G-30	DIRIS G-40	DIRIS G-50	DIRIS G-60
Communication	RS485 Modbus	•	•	•	•
	Radio frequency Communication (wireless)		•		•
	Ethernet	•	•	•	•
	WEBVIEW embedded web server	•	•	•	•
	Power Monitoring	•	•	•	•
	Power & Energy Monitoring	•	•	•	•

Functions

DIRIS G-30 / DIRIS G-50

- RS485 and Ethernet ports (2 ports with integrated switch)
- Automatic addressing and detection of connected devices.
- Historical of measurements: max 1 year
- Internal clock (SNTP synchronisation)
- Sending of alarm by email (SMTP)
- WEBVIEW embedded web server

DIRIS G-40 / DIRIS G-60

- Same functions as DIRIS G-30/G-50
- Wireless connection

Architecture

Example of communication architecture with DIRIS G gateway and WEBVIEW embedded WEB server

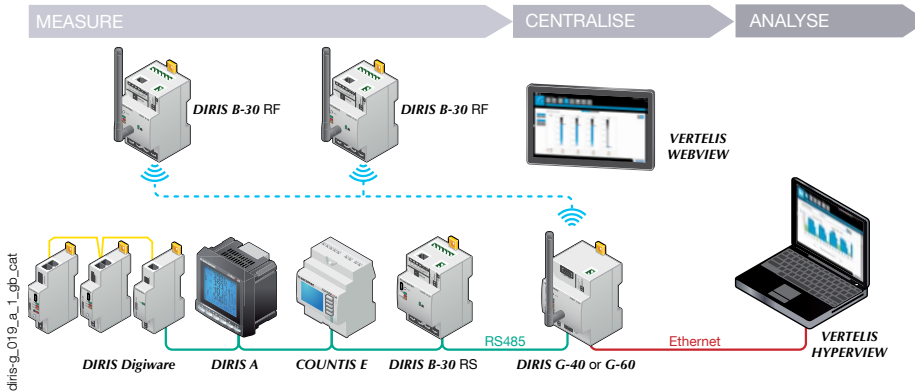

Tablet

D-90 Touch-screen tablet

- Door mounting
- Connected to Ethernet or Wi-Fi (via router)



Embedded web server

WEBVIEW embedded web server⁽¹⁾

- Power Monitoring version: embedded in DIRIS G-30 and G-40
- Power & Energy Monitoring version: embedded in DIRIS G-50 and G-60
- 32 devices max (RS485 and wireless indifferently)



(1) For more details see page 138.

DIRIS O optional modules

Maximum 4 optional modules can be connected to a DIRIS G gateway to ensure control/command functions.

DIRIS O-iod	2 digital inputs / 2 digital outputs
DIRIS O-ioa	2 analogue inputs / 2 analogue outputs
DIRIS O-it	3 temperature inputs
DIRIS O-m	Additional RS485 slave communication

For more information see DIRIS O optional modules see page 27.

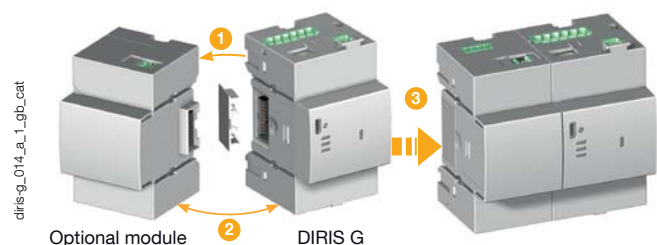

Accessories

Remote radio antenna

- Allows the antenna to be mounted outside the enclosure to increase the transmission distance up to 300 m if there are no obstacles.

USB configuration cable

- Configuration of DIRIS G gateways can be achieved using the EASY CONFIG software via Ethernet or direct USB connection.

Wifi router

- The wifi router is connected to the gateway to allow wifi access to the WEBVIEW web server via the D-90 tablet.

DIRIS G terminals

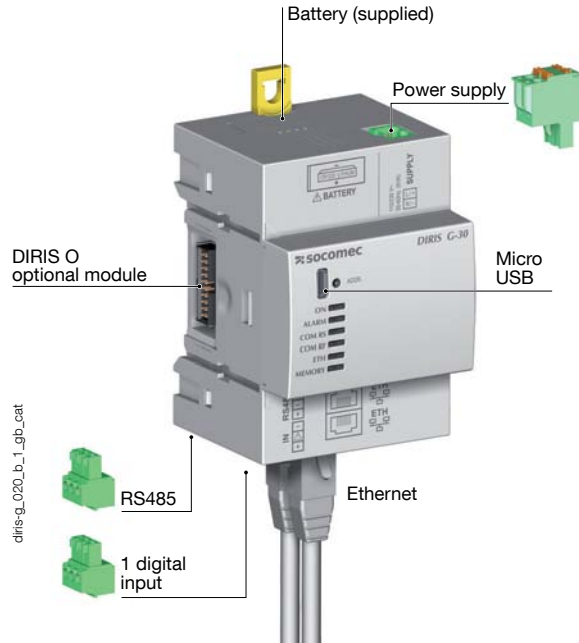

Power supply

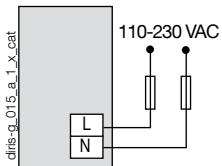

Input supplied by the product

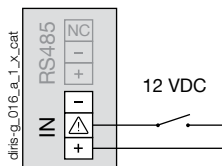

Input with external power supply

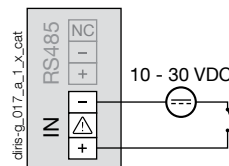

RS485

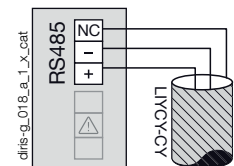

Terminals of DIRIS O optional modules

Optional modules are common to the DIRIS B-30 monitoring device.
For terminal description, see page 28.

Dimensions (mm)

DIRIS G-30 / G-40 / G-50 / G-60

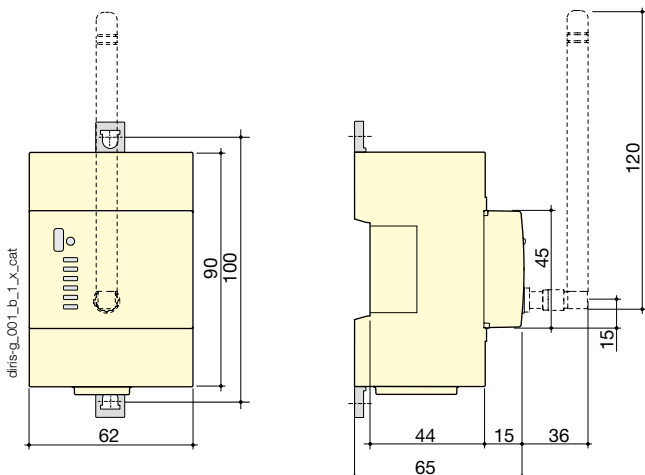

DIRIS O optional modules

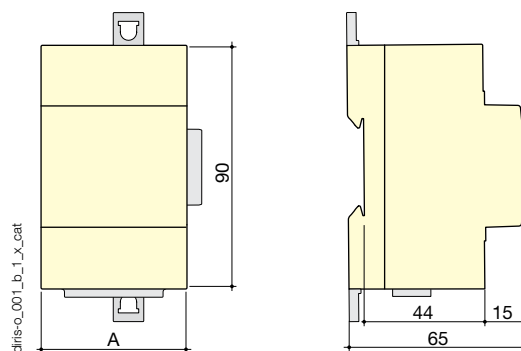

DIRIS O optional modules

DIRIS O-iod - DIRIS O-ioa - DIRIS O-it

A

45 mm

Technical characteristics

Mechanical characteristics	
Casing type	Modular for DIN-rail or back plate mounting
Case degree of protection	IP20 / IK06
Front degree of protection	IP40 (panel face with modular mounting) / IK08
Weight	DIRIS G-30, G-50 = 190 g DIRIS G-40, G-60 = 215 g
Electrical characteristics	
Power supply	
AC voltage	110-230 VAC \pm 15% (Ph/N or Ph/Ph) Cat III
Frequency	50/60 Hz
Consumption	6 VA
Battery	CR 1220 3 V lithium button cell battery
Input	
Number	1
Type / Power supply	Optocoupler internal polarisation (12 VDC \pm 10 %) or external polarisation (10-30 VDC \pm 10%)
Input function	Logic status, pulse meter or synchronisation pulse status
Communication characteristics	
DIRIS G	
Link	RS485
Connection type	2 ... 3 half duplex wires
Protocol	Modbus RTU
Speed	2400 ... 115200 bauds
Function	Communication with PMDs and meters
DIRIS G-40 and DIRIS G-60	
Link	Radio frequency (wireless)
Frequency band	868 MHz (low frequency: 868.1 MHz and high frequency: 869.5875 MHz)
Speed	38400 bauds
Function	Communication with DIRIS B-30 RF
Scope	300 m (open field)
Ethernet	
Link	Ethernet 10/100 base-T, 2 RJ45 bases with integrated switch
Protocol	Modbus TCP (port 502), Modbus RTU over TCP (port 503), HTTP, SMTP, SNTP, DHCP
Clock	Internal
SNTP protocol	Gateway time updating from an NTP server. Connected PMDs time updating.
SMTP protocol	Sending of alarm emails from the gateway
Function	Configuration of the gateway, connected PMDs and meters Access to the WEBVIEW web server, data centralisation
USB	
Connection type	USB 2 (Easy Config software required)
Protocol	Modbus RTU over USB
Function	Configuration of the gateway, connected PMDs and meters
Connection	B-type micro USB connector
Memory capacity	
Historical of consumptions (memory capacity extension of meters and monitoring devices)	1 year (1-hour period)
Electrical values	2 months (10-minute period)
Number of events	Alarms: 1000 Network quality as per EN 50160: 1000
Environment characteristics	
Operating temperature	-10 ... +70 °C
Storage temperature	-25 ... +85 °C
Operating humidity	55 °C / 97% relative humidity

References

DIRIS G gateways		Reference
DIRIS G-30	RS485 / Ethernet - WEBVIEW Power Monitoring	4829 0300
DIRIS G-40	RS485-RF / Ethernet - WEBVIEW Power Monitoring	4829 0301
DIRIS G-50	RS485 / Ethernet - WEBVIEW Power & Energy Monitoring	4829 0302
DIRIS G-60	RS485-RF / Ethernet - WEBVIEW Power & Energy Monitoring	4829 0303
DIRIS O optional modules		Reference
DIRIS O-iod	2 digital inputs / 2 digital outputs	4829 0030
DIRIS O-ioa	2 analogue inputs/2 analogue outputs, 4-20 mA	4829 0031
DIRIS O-it	3 temperature inputs PT 100 / PT 1000	4829 0032
DIRIS O-m	RS485 Modbus communication	4829 0033
Tablet		Reference
DIRIS D-90		4829 0210
Accessories		Reference
Wireless remote antenna, 868 MHz - 210 mm height		4854 0126
Cable for remote antenna - SMA connector - 3 meter length		4854 0127
USB configuration cable		4829 0050



Datalogger

Communication gateways

new

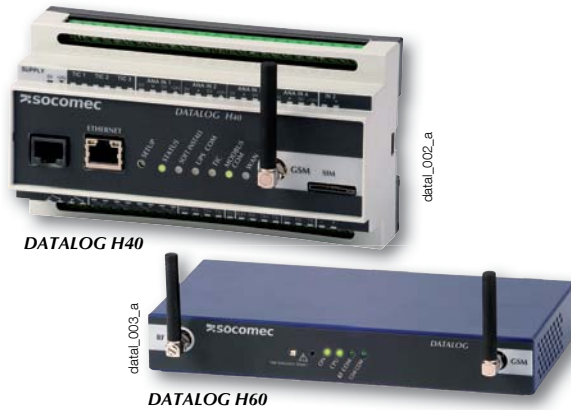

The solution for

- > Industry
- > Building
- > Infrastructure
- > Local authority



Strong points

- > Easy to install
- > Reliable transmission
- > Flexible solution

Services and Technical Assistance

- > Technical site audits and solution specification, commissioning, maintenance, training... Our Services & Technical Assistance experts offer you personalised support to ensure success with all your projects.

Function

DATALOG H40 and H60 dataloggers associated with Socomec wireless interfaces enable you to create a smart energy data communication network in order to:

- Remotely and automatically read multi-fluid energy meters and multi-function meters, isolated or not.
- Centralise, secure and make available single or multi-site data to a monitoring software,
- connect your meters and multi-function meters in a 2G/3G/GPRS network.

Advantages

Easy to install

- Quick fitting on DIN-rail ⁽¹⁾.
- Compact.
- Remote configuration by SMS.
- Guided configuration.(SOCOMECEC service).

Reliable transmission

- Configurable polling frequency for each device.
- Storage in datalogger for periodic wireless secure transmission (daily, weekly, etc.).
- Ethernet network compatible.
- GPRS ⁽¹⁾ or 2G/3G/GPRS ⁽²⁾ compatible.

Flexible solution

Data collection via different links:

- Modbus on RS232, RS485 or Ethernet port,
- M-Bus,
- Remote Customer Information (TIC) inputs,
- analogue inputs,
- pulse inputs,
- wireless M-Bus radio receiver.

(1) H40 only. (2) H60 only.

The SOCOMECEC communicating energy-efficiency solution

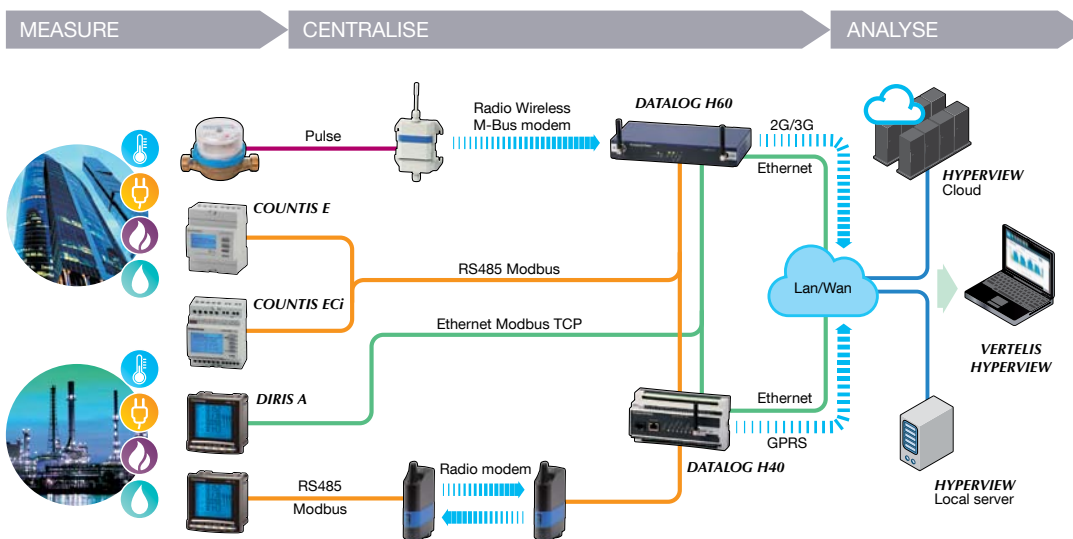

data1_006_c_gb

Functions

DATALOG H40

- Modbus on RS232 or RS485 or Ethernet (selection by software configuration).
- Local history logging and configurable polling frequencies.
- 4 inputs/2 outputs (digital) and 4 analog inputs.
- GPRS.
- Data export in .CSV format.
- Remote Customer Information (TIC 3 meters).
- Remote configuration by SMS.

DATALOG H60

- Modbus on RS485 or Ethernet (selection by software configuration).
- Mbus or Modbus on RS232 port.
- Wireless M-Bus RF bands 868 MHz (contact us for other frequency ranges).
- Local history logging and configurable polling frequencies.
- 3 inputs/1 output (digital).
- 2G/3G/GPRS.
- Data export in .XML format.
- Remote configuration by SMS.

Accessories

GSM/GPRS antenna for DATALOG H40 and H60

- 5-, 10- and 20-metre remote antenna (support not supplied).

Auxiliary power supply

- Auxiliary power supply, DIN-rail mounting 230 ± 12...24 VAC.
- External auxiliary power supply 230 ± 12...24 VAC.

Connection

DATALOG H40

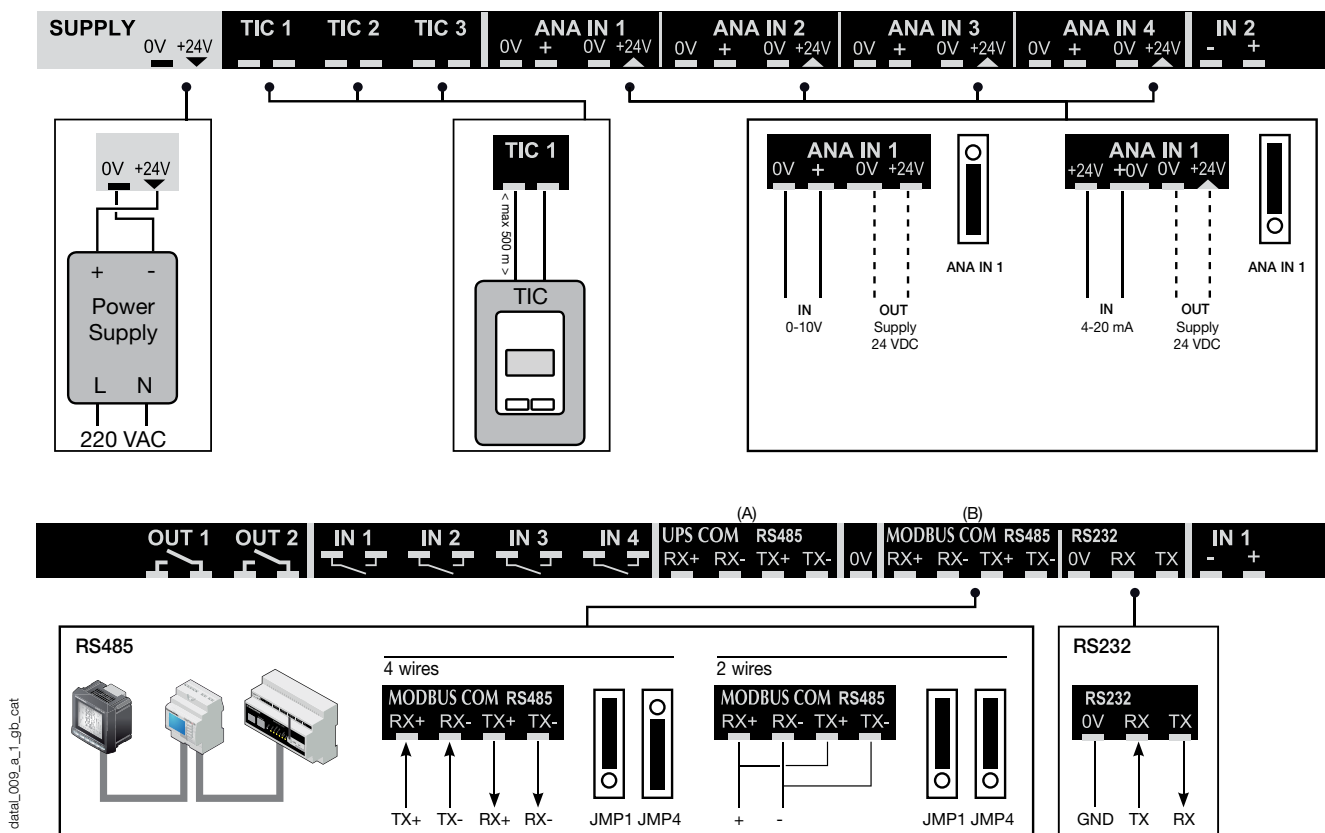

datalog_009_a_1_gbr_cat

Datalogger

Connection (continued)

DATALOG H60

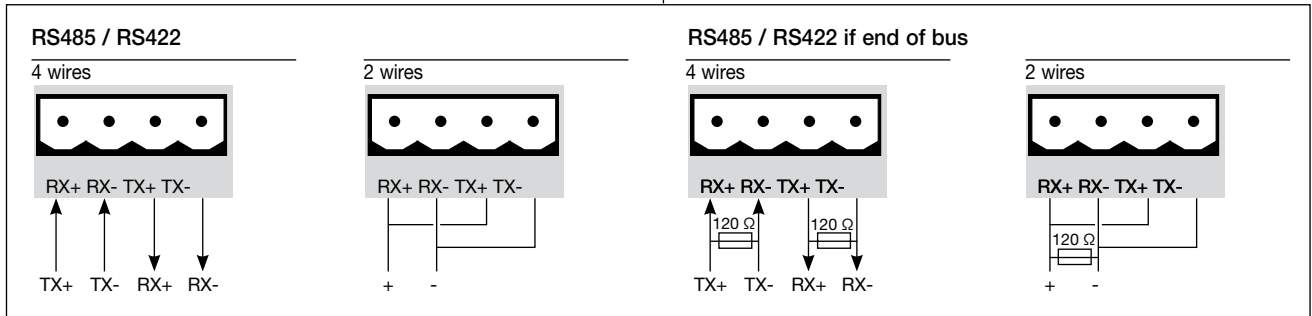
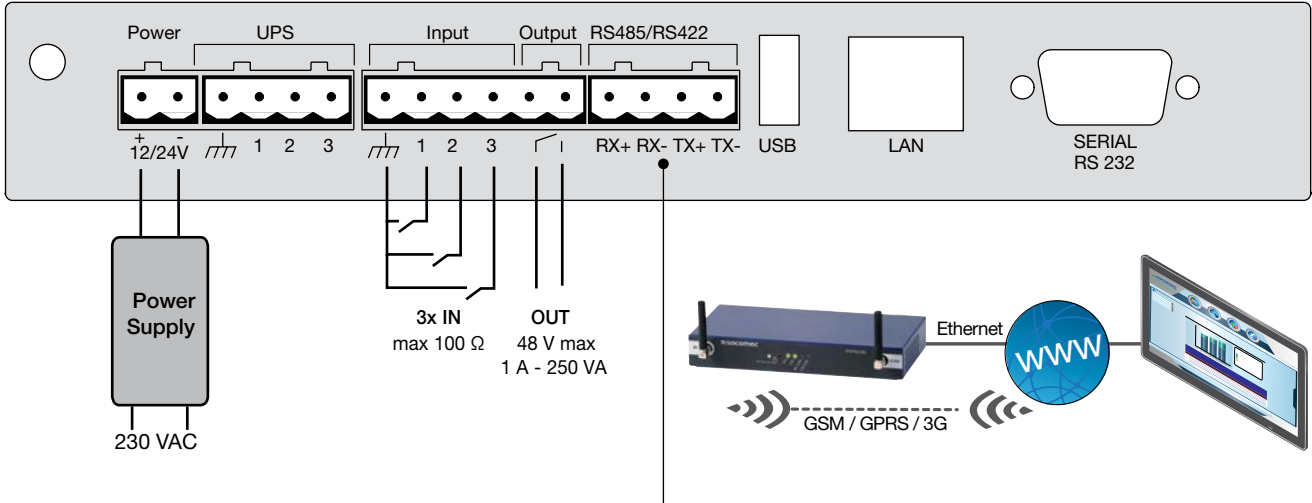

Dimensions

DATALOG H40

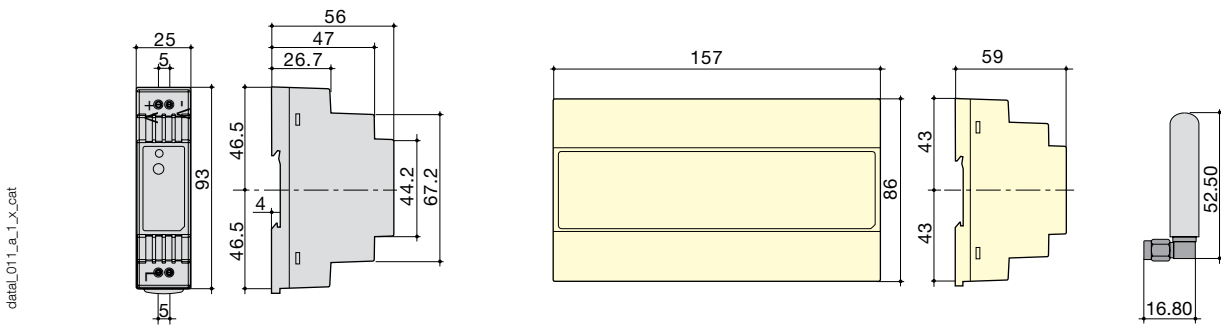

Dimensions (continued)

DATALOG H60

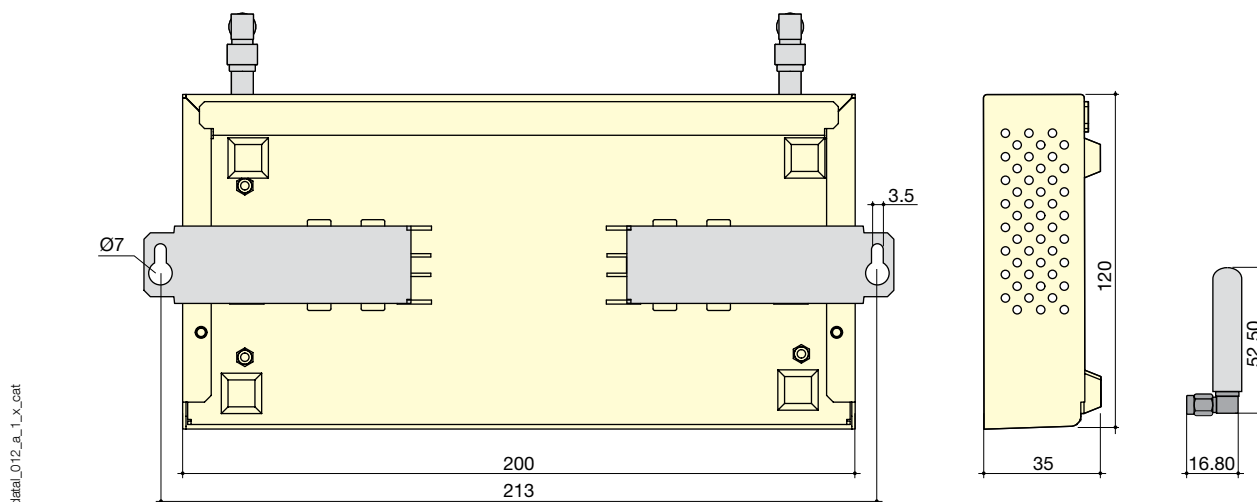

Specifications

	DATALOG H40	DATALOG H60
Input/output interface		
Inputs	4 digital inputs and 2 pulse inputs 4 analogue inputs (0-10 V, 4-20 mA)	3 digital or pulse inputs
Output	2 digital outputs (relay)	1 digital output (relay)
TIC (Remote Customer Information, France only)	3 inputs	-
Serial interfaces		
RS485	2 ports (1 Modbus, 1 Modbus-inverter)	1 port (Modbus)
RS232	1 port (Modbus)	1 port (Modbus or M-Bus)
Radio interface		
Wireless M-Bus	-	868.3 - 868.95 MHz
Network interface		
Ethernet	10/100 Mb	10/100 Mb
GSM/GPRS	850/900/1800/1900 MHz	850/900/1800/1900 MHz
3G	-	900/2100 MHz
General specifications		
Supply voltage	+12 V or +24 VDC	+12 V or +24 VDC
Dimensions W x H x D	DIN rail 157 x 86 x 59 mm	200 x 120 x 32 mm
Operating temperature range	-5 °C ... +50 °C	-20 °C ... +70 °C
Storage temperature range	-20 °C ... +85 °C	-20 °C ... +85 °C

References

Datalogger	References
DATALOG H40 (power supply included)	4854 0000
DATALOG H60 (power supply included)	4854 0001
DATALOG TIC	Contact us
Accessories	References
Remote antenna, 5 m	4854 0105
Remote antenna, 10 m	4854 0110
Remote antenna, 20 m	4854 0120
Auxiliary power supply, DIN-rail mounting 230 ± 12...24 VAC	4854 0200
External auxiliary power supply 230 ± 12...24 VAC	4854 0201



Radio communication interfaces

new



Wireless M-Bus Modem



ARF868 Modem

The solution for

- > Industry
- > Building
- > Infrastructure
- > Local authority



Strong points

Wireless M-Bus Modem

- > Battery life
- > Ease of installation
- > Long range
- > 2 pulse inputs

ARF868 radio modem

- > Sensitivity, transmission/reception quality
- > Ease of installation
- > Long range
- > Several types of communication

Services and Technical Assistance

- > Our expertise extends to a complete offer of customised services, such as technical site audit and solution specification, commissioning, training, maintenance, and project engineering.

Function

Wireless M-Bus Modem

Wireless M-Bus AMR (Automatic Meter Reading) plug-and-play modems automatically collect energy data from water and gas meters.

100% compatible with the Wireless M-Bus standard (EN13757-3 and EN13757-4), device open protocols ensure full interoperability with other Wireless M-Bus products on the market.

ARF868 radio modem

ARF868 radio modems convert data from a serial link into a radio frame to send to a similar device in the frequency range 863-870 MHz. The power and sensitivity allow the data to be transmitted over distances of up to 20 km.

Advantages

Wireless M-Bus Modem

Battery life

- Runs on battery for up to 12 years.

Long range

- Up to 1 km. Range can be increased by installing repeaters.

Ease of installation

- Factory pre-programmed.
- Quick installation.
- Robust IP65.

2 pulse inputs

- A single transmitter can handle two meters.
- Compatible with all water and gas meters.

ARF868 radio modem

Sensitivity, transmission/reception quality

- Power 25 mW or 500 mW at 868 MHz.
- Licence-free frequencies on European bands (863 - 870 MHz) or frequencies subject to license (410 - 470 MHz).

Ease of installation

- Quick installation.
- User-friendly and configuration with intuitive software.
- The product can be configured as a transmitter, receiver or repeater.

Long range

- 1 to 20 km.

Several types of communication

- RS485, RS232 or USB serial port.

General characteristics

Wireless M-Bus Modem

Emitter

Radio transmission of metering data (consumption) every 10 minutes (10s or 12hrs optional). Compatible with the majority of water & gas meters.

Repeater

- Wireless M-Bus radio relay of metering data (consumption).
- Multiple repeaters can be used to extend the range.
- Mains or battery powered (optional).

Receiver

- Wireless M-Bus metering data (consumption) radio receiver.
- RS485, RS232 or USB serial port.
- Remote antenna.

Temperature sensor

- Radio temperature transmission.
- Internal temperature sensor (supplied) and external temperature sensor (not supplied).
- Range up to 600 m (T1 mode).

ARF868 radio modem

Each receiver can communicate with a single repeater and several transmitters-receivers.

- Multiple transmission channels.

3 communication modes

- Transparent: The modem talks to everybody.
- Network: The modem talks to a group.
- Addressed: The modem talks to an addressee.

Accessories

- 1-, 3- and 5-metre remote antenna.
- Antenna mount & adaptor.
- Power supply unit + connector (required).
- TNC converter pack.
- Sub D9 connector.
- IP53 and IP67 ingress protection rating.

Connection

Wireless M-Bus Modem

Standard factory setting (10 minute data report)

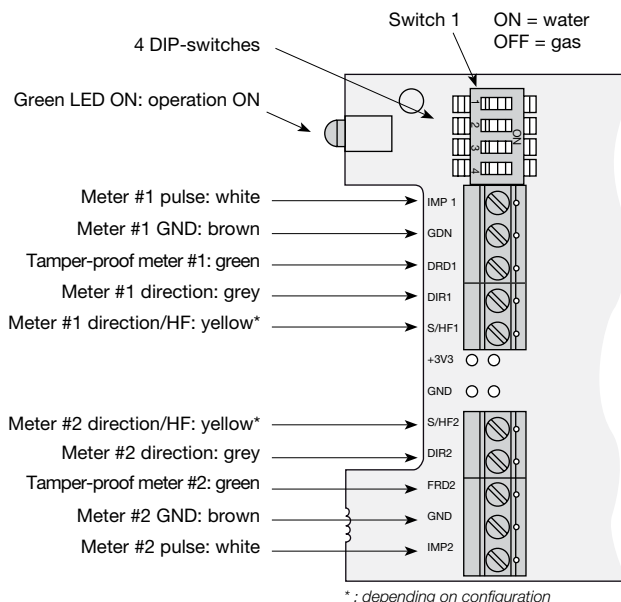

data_L013_a_1_fr_cat

ARF868 radio modem

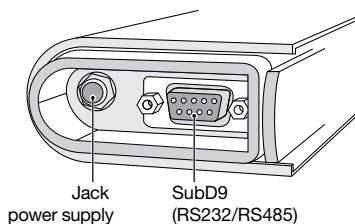

data_L014_a_1_fr_cat

Pin N°	Sub D9 modem - RS232	Sub D9 modem - RS485 ⁽²⁾
1	-	TxD+
2	RxD (Modem Data Out)	TxD-
2	TXD (Modem Data Out)	RxD+
4	-	RxD-
5	GND	
6	Sel RS232	-
7	RTS ⁽¹⁾	-
8	CTS ⁽¹⁾	-
9	Not used	

(1) RTS/CTS are only useful if you use the RS232 flow control.

(2) Half-duplex connection only.

Radio communication interfaces

Dimensions

Wireless M-Bus Modem

ARF868 radio modem

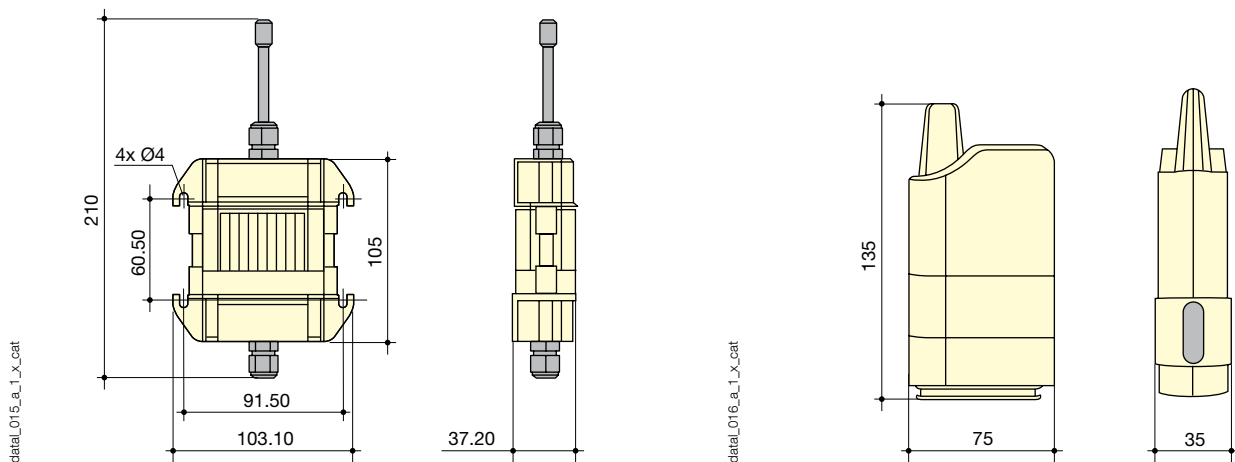

Characteristics

	Modem ARF868 (transmitter/repeater/ receiver model)	Wireless M-Bus transmitter modem: Water/Gas	Wireless M-Bus transmitter modem: Temperature	Wireless M-Bus repeater modem	Wireless M-Bus receiver modem
Scope	Up to 1/4/7/20 km according to model	Up to 1000 m	Up to 1000 m	Up to 1000 m	
Radio frequencies	863-870 MHz	863-870 MHz	863-870 MHz	863-870 MHz	863-870 MHz
Interfaces					
Inputs	-	2 pulse inputs	2 temperature inputs: - 1 pre-equipped input - 1 free input	-	-
Communication	RS232 - RS485 - USB (optional)	-	-	-	RS232 - RS485 - USB
Alerts	-	Leak detection - Fraud detection - Battery spent	-	-	-
Storage capability	-	Index bufferisation (consumption history)	-	-	-
Compatibility	-	Sappel Izar, Itron Cyble, Itron Gallus 2000, Elster BK	-	-	-
General characteristics					
Dimensions W x H x D	135 x 75 x 35 mm	210 x 103.1 x 37.2 mm	210 x 103.1 x 37.2 mm	210 x 103.1 x 37.2 mm	210 x 103.1 x 37.2 mm
Operating temperature range	-30 °C ... +70 °C	-40 °C ... +85 °C	-40 °C ... +85 °C	-40 °C ... +85 °C	-40 °C ... +85 °C
Supply voltage	4.5 ... 36 V	3.6V Li-SOCl2 battery. Battery life up to 12 years guaranteed	3.6V Li-SOCl2 battery. Battery life up to 12 years guaranteed	3.6 V. Power supply block supplied, model with battery optional	4.5 ... 36 VDC
Protection degree	IP53, IP67 (optional)	IP65	IP53	IP65	IP65
Standards	EN300-220 V2010/EN301-489/EN60950				

References

Wireless M-Bus Modem

	References
Wireless M-Bus Modem - Water	4854 0054
Wireless M-Bus Modem - Gas	4854 0055
Wireless M-Bus Modem - Temperature	4854 0056
Wireless M-Bus receiver modem – RS232	4854 0057
Wireless M-Bus receiver modem – RS485	4854 0058
Wireless M-Bus receiver modem – USB	4854 0059
Wireless M-Bus repeater modem	4854 0060

ARF868 radio modem

	References
Modbus radio modem, distance 20 km	4854 0050
Modbus radio modem, distance 7 km	4854 0051
Modbus radio modem, distance 4 km	4854 0052
Modbus radio modem, distance 1 km	4854 0053
Accessories	References
0.5 dB remote antenna, 1 m	4854 0121
0.1 dB remote antenna, 3 m	4854 0122
1.5 dB remote antenna, 5 m	4854 0123
Mounting system + TNC adapter	4854 0124
TNC converter pack	4854 0125
Power supply block + jack	4854 0202
IP53 protection	4854 0300
IP67 protection	4854 0301
RS232- USB cable	4854 0400
Solder jack socket	4854 0401
Sub D9 connector	4700 9993



Communication accessories

Connecting the RS485 link

USB / RS485 interface



inter_002_a_2_cat

Function

If the PC is not equipped with a serial port, this interface can be connected via a USB port to obtain an RS485 communication port. Recommended for local use and not for permanent installation.

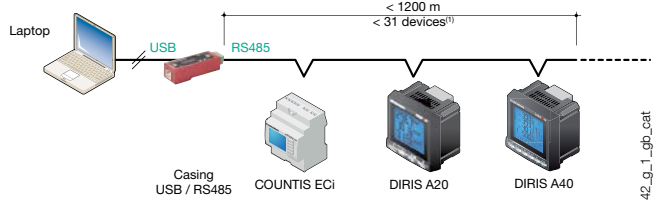

(1) Beyond these characteristics, use an "RS422 / RS485 repeater".

inter_142_g_1_gp_cat

References

Description of accessories	Reference
External USB / RS485 interface unit	4899 0110

RS422 / RS485 repeater

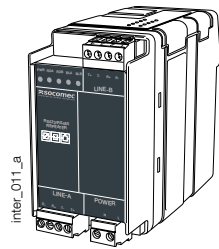

inter_011_a

Function

In some applications the maximum distance and/or the maximum number of devices can be exceeded. One solution to this technical restriction is to install an interface which amplifies the signal over a further 1200 m (at 9600 bauds) for 31 devices.

In addition, it allows you to introduce a new branch to the network, thereby making it possible to reduce the length of connection cable required by avoiding back and forth cabling.

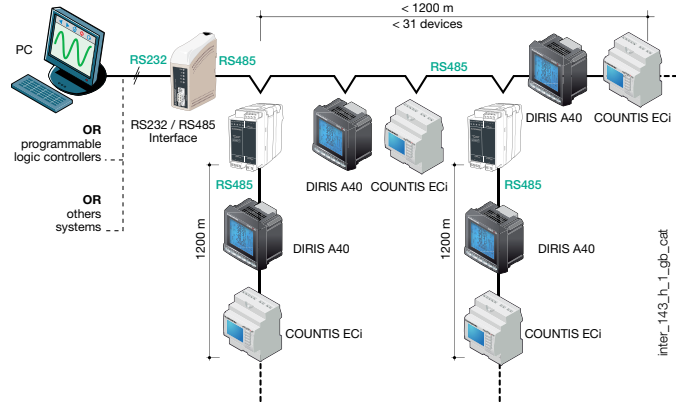

inter_143_h_1_gp_cat

References

Auxiliary power supply U_s	Frequency	Reference
95 ... 240 VAC / 110 ... 250 VDC	50 Hz	4899 0120

Using the telephone network (RTC Modem / RS232 - RS485)

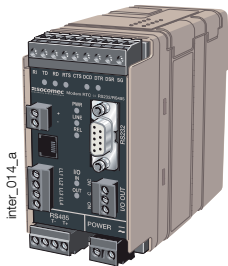

Function

On some sites it is not possible to connect all devices using a single cable. In some cases, the distances may be such that the investment would be too great. In these conditions a possible solution is a modem, utilising existing telephone lines to complete the network. This modem can be configured as a master (RS232: connected directly to PC) or slave (RS485: connected to slave devices, via network).

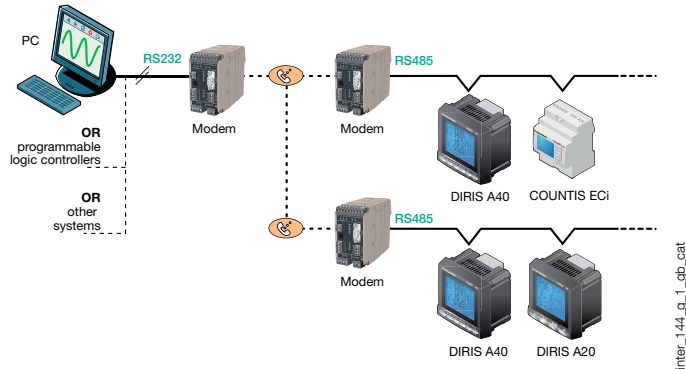

References

Auxiliary power supply U _s	Frequency	Reference
22 ... 240 VAC / 12 ... 48 VDC	50 Hz	4899 0200

Using the Ethernet network (Ethernet / RS232-RS485 interface)



Function

This interface enables RS485 slave devices to be connected to an Ethernet network. These interfaces can be configured differently to suit other architectures.

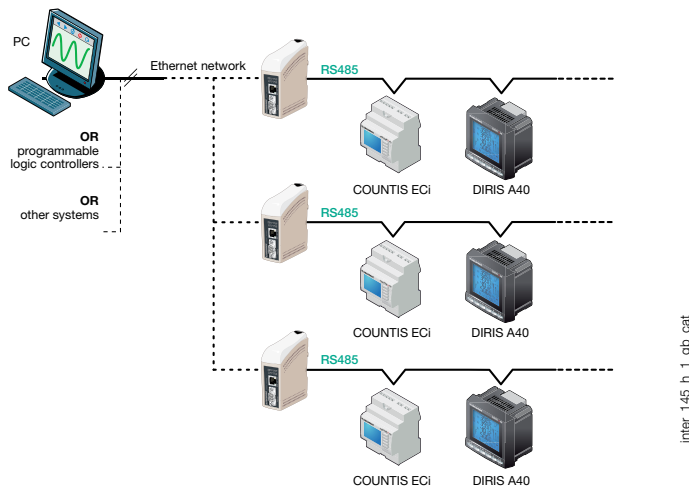

References

Auxiliary power supply U _s	Frequency	Reference
230 VAC / 12 ... 48 VDC	50 Hz	4899 0300

Other solutions and services

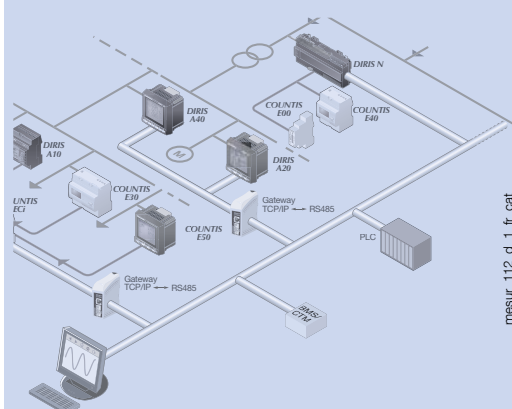

The accessories listed in these pages represent a selection from our range.

We can supply many other solutions upon request, such as SHDSL interfaces, fibre optics/RS485, GSM/GPRS and protocol converter interfaces.

Need something integrating into your network?

No problem with our **Services and Technical Assistance**.

Our Services and Technical Assistance department will fully integrate all your SOCOMEC devices. This team of experts offers a complete range of customised solutions, including technical site audit and solution specification, commissioning, training, maintenance, and project engineering.

For further information, please contact your SOCOMEC branch office.



VERTELIS WEBVIEW

Web server embedded in the DIRIS G communication gateway

Software suite

new



The solution for

- > Industry
- > Building
- > Infrastructure
- > Local authority



Strong points

- > Plug & Play
- > Easy to use
- > Various functions

Function

The **WEBVIEW** web server embedded in DIRIS G gateways enables measurement monitoring up to 32 devices and displays the energy consumptions by usage.

Pre-set alarms defined by the user can sent by e-mail.

User can access WEBVIEW via a web browser on a PC or a tablet.

Advantages

Plug & Play

Automatic detection of connected devices facilitates the WEBVIEW configuration. In order to achieve the consumption distribution, the user is assisted in the metering plan definition.

Easy to use

WEBVIEW centralises all the devices measurements via a unique, clear and easy-to-use interface.

It provides easy and rapid monitoring of the devices by displaying the parameters and events on summary pages.

Various functions

WEBVIEW ensures real time monitoring of all electrical parameters measured thanks to summary pages showing graphs or charts. Time-logged alarms are recored and displayed by usage, type, nature and criticality. The user receives alarm notification by email.

Energy consumption breakdown is displayed per utility (electricity, water, gas...) and usage (heating, lightning...).

Selection guide

WEBVIEW	Functions	Hosted on Gateway (32 devices max.)
Power Monitoring	Monitor - Real time measurement - Alarms	DIRIS G-30
		DIRIS G-40
Power & Energy Monitoring	Monitor - Real time measurement - Alarms Display - Measurement history - Consumptions	DIRIS G-50
		DIRIS G-60

Functions

2 versions available:

Power Monitoring

Monitor

- Automatic detection of connected devices.
- Summary of the parameters measured on the electrical network and the loads.
- Measurements of voltage, current, power, power factor, harmonic distortion rate (THD) and harmonics per rank.
- Display of average/instantaneous values with min/max limits depending on the devices.
- Total and partial energy consumption per load.
- Input/output status.
- Synchronisation of device clocks.
- Graphical or table representation.

Alarm

- Alarms for overloads, events and input status changes.
- Display of alarm history.
- Sorting by type, nature, criticality or state.
- Alarm displayed on the main page.
- Sending of alarm by email (SMTP).

Power & Energy Monitoring

Display

- Historical measurements and consumption (one year of data).
- Distribution of consumption by usage and by utility (water, gas, electricity, etc.).
- Export of consumption data in CSV format.

Power & Energy Monitoring also includes the "Monitoring" and "Alarm" functions.



Real-time display.

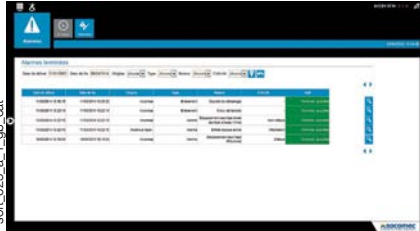

Alarm history.



Consumption history.

Architecture

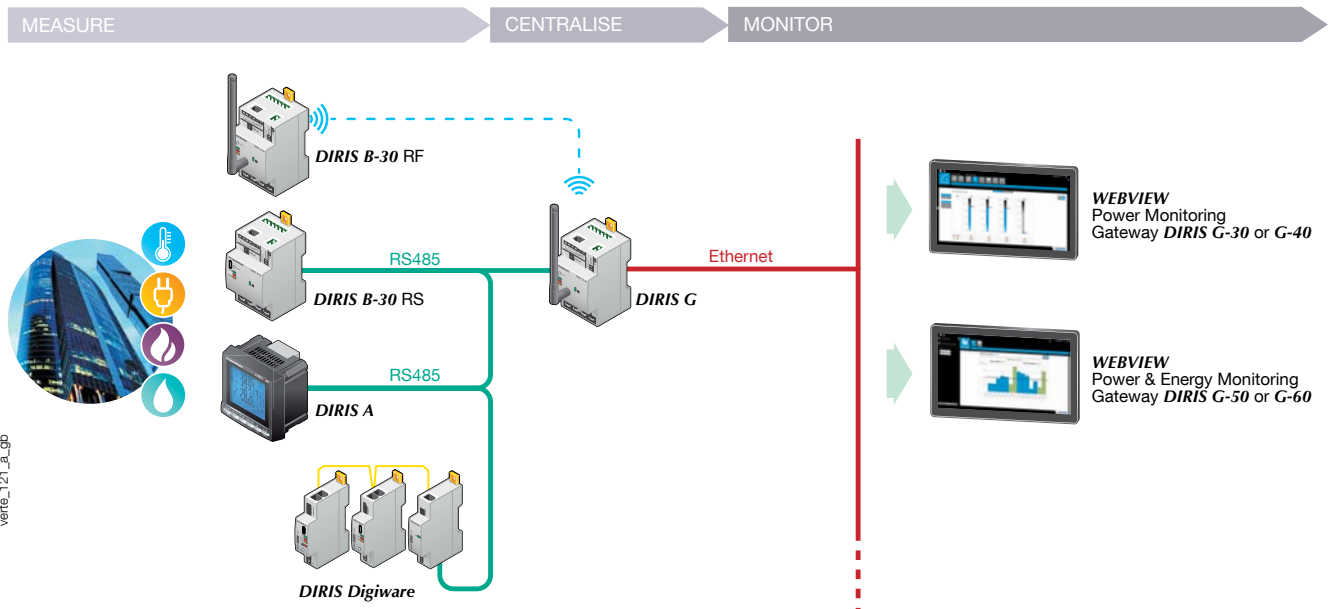

References

Type	Reference
DIRIS G-30	RS485 / Ethernet - WEBVIEW Power Monitoring 4829 0300
DIRIS G-40	RS485-RF / Ethernet - WEBVIEW Power Monitoring 4829 0301
DIRIS G-50	RS485 / Ethernet - WEBVIEW Power & Energy Monitoring 4829 0302
DIRIS G-60	RS485-RF / Ethernet - WEBVIEW Power & Energy Monitoring 4829 0303



VERTELIS *HYPERVIEW*

Energy Management Software

Software suite

new



The solution for

- > Industry
- > Building
- > Infrastructure
- > Local authority



Strong points

- > Energy cost management
- > Advanced analysis functions
- > Rapid results

Function

HYPERVIEW software is for consolidating all the data collected by measuring and metering devices.

Based on open-ended technologies, it can be easily integrated into the IT environment.

A simple and user friendly web interface enables access to various analysis and power consumption optimisation functions.

Advantages

Energy cost management

The **HYPERVIEW** software provides summary on energy savings achieved following the implementation of energy efficiency actions. Data about energy contracts and bills are registered into the system in order to reduce the energy costs. Functions for optimising the subscribed power enable the identification of overcosts, and thus the possibility adapt usage and/or the subscription.

Rapid results

HYPERVIEW is an intuitive and user-friendly tool. Data can always be accessed thanks to the web portal displaying analysis reports with dashboards or graphs. The **HYPERVIEW** software allows users to subscribe to reports and receive them by regular email.

Advanced analysis functions

The management of **SOCOME C** devices load curves provides accurate analysis of consumptions and enables the detection of active and reactive powers maximums and overruns. Thanks to calculated measurement points, consumptions that cannot be measured can be deducted through calculations. Customised consumption models based on relevant indicators facilitate the implementation of a performance measurement and verification protocol.

Selection guide

Hyperview	up to 200 devices	> 200 devices	Functions	Options
Energy Management	Hosted on local server	Hosted on local server ⁽¹⁾	Monitor and analyse <ul style="list-style-type: none"> • Consumption analysis • Exceeded threshold alerts • Energy cost management Follow up your results <ul style="list-style-type: none"> • Integration of external data (temperature, etc.) • Estimation of results achieved • Display of energy savings and losses Communicate <ul style="list-style-type: none"> • Dashboards • Report subscription • Full screen dashboards 	Monitor <ul style="list-style-type: none"> • Graph creation tool Analyse <ul style="list-style-type: none"> • Electrical powers • Customised reports Follow up your results <ul style="list-style-type: none"> • Measurements and verifications
Energy Management Cloud	Data centers			

(1) Architecture: please consult us.

Functions

Energy management

Monitor and analyse

- Measurement and consumption history.
- Alarms for overloads, events & input status changes.
- Display and export of the data collected.
- Distribution of consumption by area, usage, utility and period.
- Identification of energy saving opportunities.
- Comparison of consumption between different sites and periods.
- Calculation and display of energy costs.

Follow up your results

- Integration of external data (temperature, etc.).
- Definition of energy consumption models.
- Estimation of the results of your energy performance actions.
- Identification of savings and losses comparing consumption over a reference period.

Communicate

- Display of customised full screen dashboards in key areas.
- Subscribe to reports and receive them by regular email.
- Presentation of the data in a concise manner to communicate and report about environmental performance.



Consumption analysis

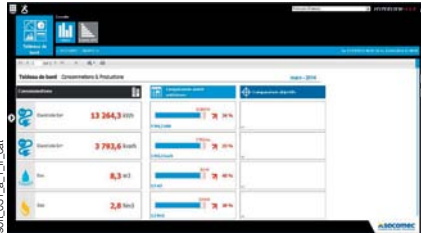

Dashboards



Energy label

Architecture

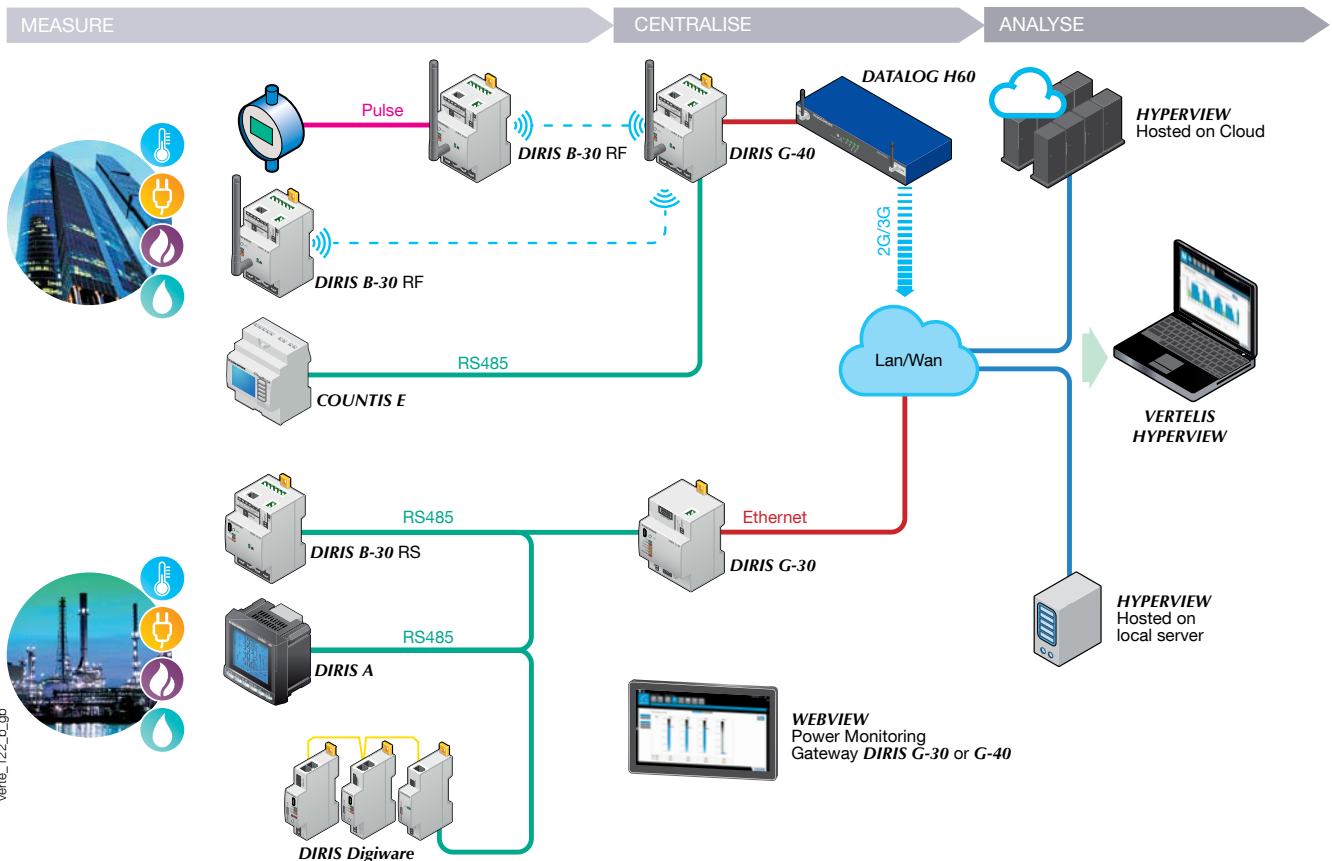

References

HYPERVIEW	Reference
HYPERVIEW on Server + software license	Please consult us
HYPERVIEW on Cloud + software license	Please consult us

Options	Reference
Graph creation tool	Please consult us
Electrical powers	Please consult us
Measurements and verifications	Please consult us



COUNTIS and DIRIS management software tools

Software suite

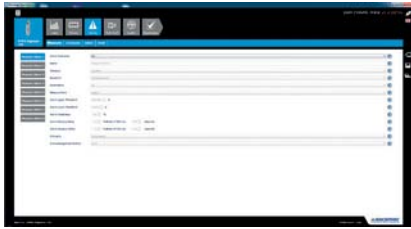

Easy Config software



Analysis software

Compatible with:



COUNTIS E



DIRIS A



DIRIS Digiware



DIRIS B30

Function

To get the most effective use from your Socomec measurement and metering devices, we can provide dedicated software tools:

Easy Config software

The Easy Config software enables quick and easy remote device configuration for DIRIS Digiware, DIRIS B, DIRIS G, DIRIS BCMS 720, COUNTIS E and DIRIS A devices. Configuration files can be copied from and sent to these devices, or they can be created without communication and sent at a later time.

Multiple devices can be configured from a single file which is especially useful for OEMs and panel builders, saving time when having to program many devices with the same configuration.

Analysis software

On the basis of an event log and the displayed curves, the Analysis software allows the analysis and extraction of quality data, as well as fault current monitoring (Residual Current Monitoring).

Webserver function

The DIRIS A's optional Ethernet modules integrate HTML pages, enabling the Webserver function to be directly accessed through a standard web browser (Internet Explorer, Firefox...), eliminating the need for software installation.

The Webserver function enables:

- monitoring of electrical values,
- viewing of energy consumption,
- managing alarms,
- configuration of the main parameters of installation
- viewing and extracting load curves (through a .CSV file).

Principle diagram

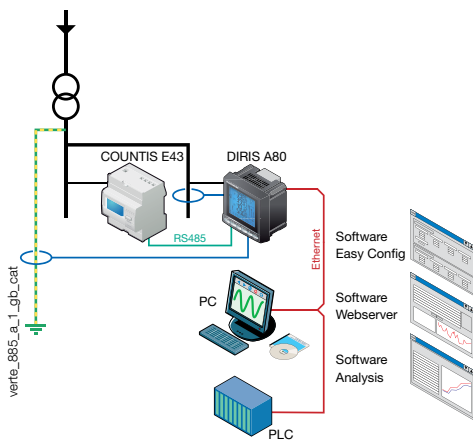

	Easy Config	Webserver	Analysis	WEBVIEW <small>See page 138</small>	HYPERVIEW <small>See page 140</small>
COUNTIS E with RS485 communication	•	• ⁽¹⁾		•	•
COUNTIS Eci	•	• ⁽¹⁾		•	•
DIRIS A10, A14, A17 and A20 with RS485 communication	•	• ⁽¹⁾		•	•
DIRIS A40 with RS485 communication	•	• ⁽¹⁾		•	•
DIRIS A40 with Ethernet communication module	•	•		•	•
DIRIS A60 and A80 with RS485 communication module	•	• ⁽¹⁾	•	•	•
DIRIS A60 and A80 with Ethernet communication module	•	•	•	•	•
DIRIS B	•			•	•
DIRIS Digiware	•			•	•
DIRIS G	•			•	•
DIRIS BCMS 720	•	•			•

(1) through DIRISA fitted with an Ethernet communication module with RS485 gateway.

Easy Config software



The Easy Config software enables quick and easy remote configuration of DIRIS Digiware, DIRIS B, DIRIS G, DIRIS BCMS 720, COUNTIS E and DIRIS A devices.

It offers the following functions:

- Creating the configuration of devices prior to their connection (configuration template).
- Saving a configuration to a PC.
- Loading the configuration to devices through USB, RS485 or Ethernet.
- Retrieving the configuration of a device through USB, RS485 or Ethernet for saving, copying or modification purposes.

diris_886_a_1_gb_cat

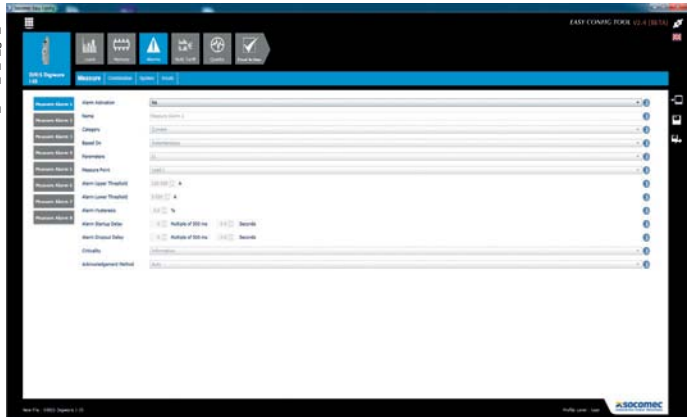

Configuration of loads

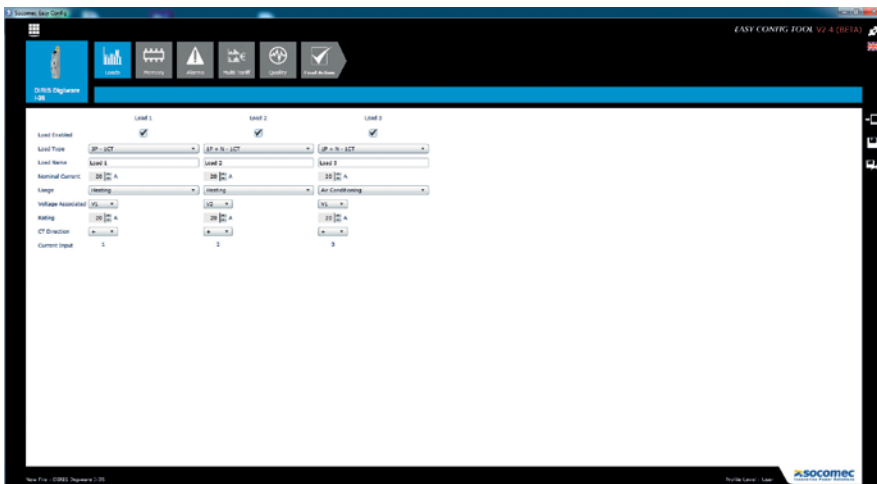

diris_883_a_1_gb_cat

Configuration of Quality events

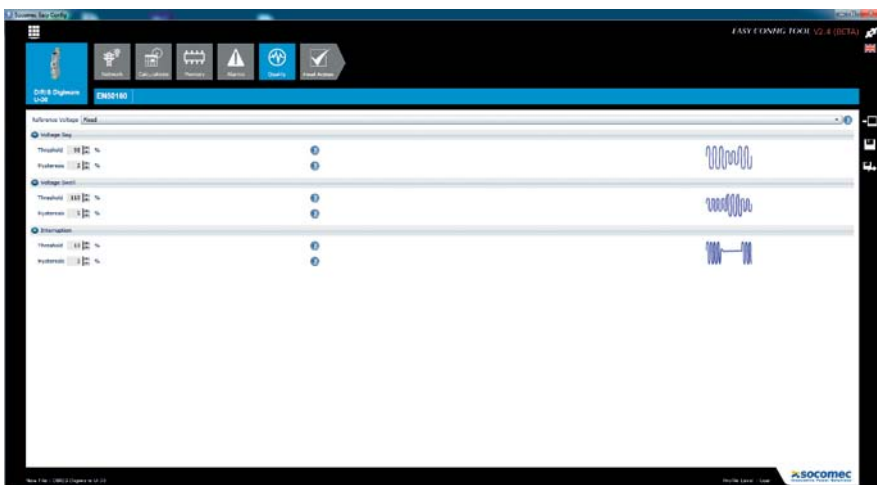

diris_884_b_1_gb_cat

COUNTIS and DIRIS

management software tools

Analysis software

Improvement to the reliability of your electrical installation can be achieved with this software through the analysis of displayed event curves generated from the event log.

It offers the following functions:

- A list of voltage dips, cut-offs, overvoltages and overcurrents.
- A list of alarms $I\Delta n$ and I_{PE} for DIRIS A80.
- A display of 10 curves (3V, 3U, 3I, In) linked to the event with a zoom functionality.
- The classification of events according to the EN 50160 standard.
- Exporting of pictures or curve files.

This software can be connected to the DIRIS using either an RS485 MODBUS or Ethernet communication module. The Analysis software can be downloaded from the SOCOMEC website: www.socomec.com

Event log

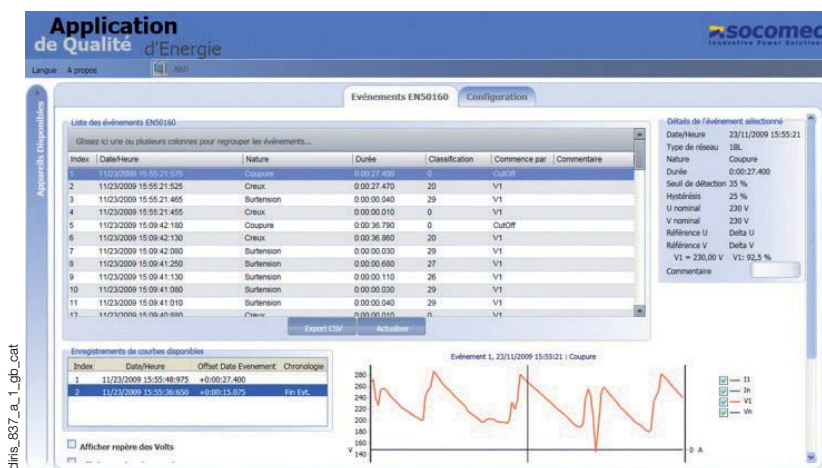

Curves display and analysis

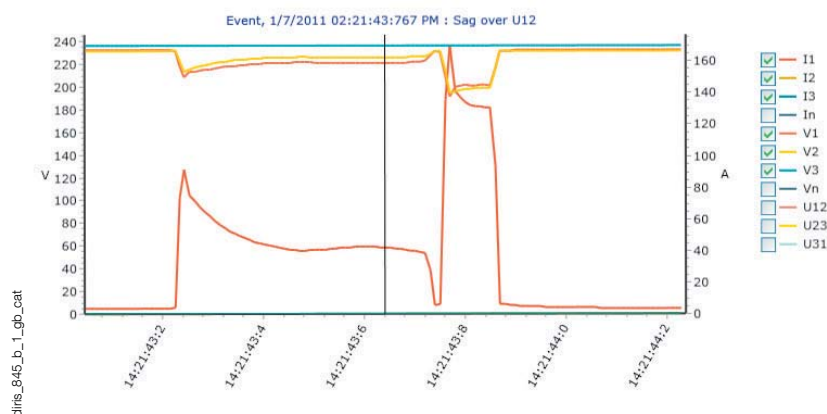

Webserver function



diris_776_a_1_cat

DIRIS A Ethernet communication module with RS485 gateway

The Webserver function comprises HTML pages embedded within the optional Ethernet communication module of the DIRIS A's multifunction meter. These pages can be accessed via an internet browser, simply by entering the DIRIS A IP address.

The Webserver offers the following functions:

- Monitoring of electrical values.
- Viewing of energy consumption.
- Management of alarms.
- Remote configuration of the main parameters for meters within the installation.
- Viewing and extracting load curves (through a .CSV file).

Instantaneous report of measurements

Valeurs instantanées

Courants		Tensions		Courants THD		Tensions THD	
L1	43.67 A	L12	414.21 V	L1	68.00 %	L12	0.70 %
L2	40.54 A	L23	412.25 V	L2	65.30 %	L23	0.90 %
L3	40.52 A	L31	410.25 V	L3	72.00 %	L31	0.80 %

Fréquence: F 80.03 Hz

Valeurs moyennées

Courants AVG		Courants max		Tensions AVG		Tensions max	
L1	45.54 A	L1	1.67 kA	L12	412.96 V	L12	424.94 V
L2	42.33 A	L2	1.64 kA	L23	410.53 V	L23	424.08 V
L3	43.32 A	L3	1.68 kA	L31	418.71 V	L31	428.31 V

diris_867_a_1_gb_cat

Display for viewing instantaneous and average electrical values.

Power and energy

Puissance: Valeurs des lignes

L1		L2		L3	
P	8.48 kW	P	13.78 kW	P	11.25 kW
Q	3.70 var	Q	3.30 var	Q	5.85 kvar
S	9.41 kVA	S	15.79 kVA	S	14.15 kVA
FP	0.8640	FP	0.8760	FP	0.7940

Puissance: Valeurs totales

Σ INST		Σ MAX		Σ AVG		Σ PRED	
P	33.45 kW	P+	990.28 kW	P+	0.00 W	P	32.24 kW
Q	6.45 kvar	Q+	627.55 kvar	Q+	0.00 var	Q	5.44 kvar
S	34.08 kVA	S	1.17 MVA	S	0.00 VA	S	32.88 kVA
FP	0.9810	FP	N/A	FP	N/A	FP	N/A

diris_869_a_1_gb_cat

Display for viewing instantaneous and average power measurements and energy consumption.

Configuration of the devices

Configuration

Configuration réseau

Type de réseau: SNBL

CT primaire (A): 125

CT secondaire (A): 5

Transfo tension présent: Non

Tp tension prim (V): 400000

Tp tension sec (V): 100

Période d'intégration

Top interne/externe: interne

Top synchro POS: 30 minutes

Max/Avg: 35 minutes

I: 30 minutes

UV: 30 minutes

P/O/S: 30 minutes

F: 30 secondes

Date/Heure configuration

Jour (1-31): 9

Mois (1-12): 11

Année (aaaa): 2011

Heure (hh:1-23): 16

Minute (0-59): 27

Seconde (0-59): 36

diris_868_a_1_gb_cat

Alarms

Instantaneous Values

I_{act}: 33.3600 A

I_{l1n}: 1.6000 A

I_{l1c}: 0.0000 A

Residual Current Alarm

Alarm on I_{l1n}: Active

Maximum: 1.6300 A

Threshold: 0.3380 A

Hysteresis: 0.3380 A

Alarm on I_{l1c}: Inactive

Maximum: 0.0000 A

Threshold: 3.3360 A

Hysteresis: 3.1600 A

Alarm History

Cause	Status	Date	Duration (minutes)

diris_884_a_1_gb_cat

The latest alarms are date and time registered. The duration and value for each alarm (low limit value / high limit value), as well as the related output alarm number, are also displayed. Data can be extracted in *.csv format.

References list

References	Pages	References	Pages	References	Pages	References	Pages
19xx xxxx	106	192U 9xxx	106	4825 0207	83	4850 3017	47
192J 8015	53	192Y 0015	99, 102	4825 0208	77, 83, 114	4850 3019	39
192M xxxx	115	192Y 0025	99	4825 0209	77, 83, 114	4850 3020	39
192S xxxx	112	192Y 0035	102	4825 021x	87	4850 3025	45
192T 0003	99, 101, 102	192Y 0045	103, 106	4825 1xxx	77	4850 3026	45
192T 0005	99, 102	192Y 0115	99, 102	4826 xxxx	95	4850 3027	47
192T 0006	101	192Y 0125	99	4827 00xx	121	4850 3028	47
192T 0007	101, 102	192Y 0135	102	4827 0100	121	4850 3029	39
192T 002x	101	192Y 0145	103, 106	4827 0106	120, 121	4850 3030	39
192T 0101	99	192Y 0155	99, 102	4827 0109	120, 121	4850 3031	41
192T 0102	103, 106	192Y 0165	99	4827 2xxx	120, 121	4850 3032	41
192T 0103	99, 102	192Y 0175	102	4827 3000	121	4850 3033	41
192T 0105	99, 101, 102	192Y 0185	103, 106	4829 000x	30	4850 3034	41
192T 0106	103	192Y 0215	99, 102	4829 0030	30, 127	4850 3035	43
192T 0255	99, 102	192Y 0225	99	4829 0031	30, 127	4850 3036	43
192T 05xx	99	192Y 0235	102	4829 0032	30, 127	4850 3036	43
192T 06xx	99	192Y 0245	103, 106	4829 0033	30	4850 3037	43
192T 08xx	111	192Y 0265	99	4829 0034	30	4850 3038	43
192T 09xx	111	192Y 0275	102	4829 0035	30	4853 xxxx	53
192T 14xx	101	192Y 0285	103, 106	4829 0036	30	4854 000x	131
192T 19xx	109	192Y 04xx	115	4829 004x	30	4854 005x	135
192T 20xx	101	192Y 05xx	115	4829 0050	25, 30, 127	4854 006x	135
192T 21xx	102	192Y 06xx	115	4829 01xx	25	4854 010x	131
192T 23xx	102	192Y 08xx	115	4829 0200	25, 30	4854 011x	131
192T 24xx	102	192Y 09xx	115	4829 0201	25	4854 0120	131
192T 32xx	102	4700 9993	135	4829 0210	127	4854 0121	135
192T 33xx	108	4825 001x	59	4829 028x	30	4854 0121	135
192T 34xx	108	4825 002x	63	4829 03xx	127, 139	4854 0122	135
192T 40xx	102	4825 007x	63	4829 05xx	35	4854 0123	135
192T 46xx	110	4825 0080	71	4829 06xx	35	4854 0124	135
192T 47xx	110	4825 0082	71	4850 3000	41	4854 0125	135
192T 48xx	110	4825 0083	71	4850 3001	41	4854 0126	30, 127
192T 5xxx	103	4825 0088	71, 77, 83, 87	4850 3002	41	4854 0127	30, 127
192T 6xxx	103	4825 0089	71, 77, 83, 87	4850 3003	43	4854 0200	131
192T 7xxx	106	4825 0090	77, 83	4850 3004	43	4854 0201	131
192T 80xx	106	4825 0092	77, 83, 87	4850 3005	45	4854 0202	135
192T 81xx	103	4825 0093	77, 83	4850 3006	45	4854 03xx	135
192T 93xx	106	4825 0094	77, 83	4850 3007	45	4854 04xx	135
192T 95xx	103	4825 0097	77	4850 3008	47	4899 0011	71, 77, 83, 87
192T 96xx	103	4825 01xx	67	4850 3009	47	4899 01xx	136
192T 97xx	106	4825 0200	71	4850 3010	49	4899 02xx	137
192U 0xxx	99	4825 0201	77	4850 3011	49	4899 03xx	137
192U 22xx	101	4825 0202	77	4850 3012	45	495x xxxx	87
192U 23xx	102	4825 0203	77, 83, 87	4850 3013	45	499x xxxx	114
192U 4xxx	102	4825 0204	77, 83, 87	4850 3014	47	5xxx xxxx	59, 67, 71, 77, 83, 87, 95
192U 6xxx	103	4825 0205	77	4850 3015	47	6xxx xxxx	59, 67, 71, 77, 83, 87, 95
192U 8xxx	106	4825 0206	77, 83	4850 3016	51		

Model: SOCOMEC
Production: SOCOMEC
Photography: Martin Bernhart en Studio Objectif
Printing:

Socomec worldwide

IN EUROPE

BELGIUM

Critical Power / Power Control & Safety /
Energy Efficiency / Solar Power Power

Tel. +32 2 340 02 30
Fax +32 2 346 28 99
info.be@socomec.com

FRANCE

Critical Power / Power Control & Safety /
Energy Efficiency / Solar Power

Tel. +33 1 45 14 63 00
Fax +33 1 48 67 31 12
dcm.ups.fr@socomec.com

GERMANY

Critical Power

Tel. +49 621 71 68 40
Fax +49 621 71 68 444
info.ups.de@socomec.com

Power Control & Safety / Energy Efficiency

Tel. +49 7243 65292 0
Fax +49 7243 65292 13
info.scp.de@socomec.com

ITALY

Critical Power

Tel. +39 02 98 242 942
Fax +39 02 98 240 723
info.ups.it@socomec.com

Power Control & Safety / Energy Efficiency

Tel. +39 02 98 49 821
Fax +39 02 98 24 33 10
info.scp.it@socomec.com

Solar Power

Tel. +39 0444 598611
Fax +39 0444 598627
info.solar.it@socomec.com

NETHERLANDS

Critical Power / Power Control & Safety /
Energy Efficiency / Solar Power

Tel. +31 30 760 0900
Fax +31 30 637 2166
info.nl@socomec.com

POLAND

Critical Power / Solar Power

Tel. +48 22 825 73 60
Fax. +48 22 825 73 70
info.ups.pl@socomec.com

Power Control & Safety / Energy Efficiency

Tel. +48 91 442 64 11
Fax +48 91 442 64 19
info.scp.pl@socomec.com

PORTUGAL

Critical Power / Power Control & Safety /
Energy Efficiency / Solar Power

Tel. +351 261 812 599
Fax +351 261 812 570
info.ups.pt@socomec.com

ROMANIA

Critical Power / Power Control & Safety /
Energy Efficiency / Solar Power

Tel. +40 21 319 36 88
Fax +40 21 319 36 89
info.ro@socomec.com

RUSSIA

Critical Power / Power Control & Safety /
Energy Efficiency / Solar Power

Tel. +7 495 775 19 85
Fax +7 495 775 19 85
info.ru@socomec.com

SLOVENIA

Critical Power / Power Control & Safety /
Energy Efficiency / Solar Power

Tel. +386 1 5807 860
Fax +386 1 561 11 73
info.si@socomec.com

SPAIN

Critical Power / Power Control & Safety /
Energy Efficiency / Solar Power

Tel. +34 93 540 75 75
Fax +34 93 540 75 76
info.es@socomec.com

TURKEY

Critical Power / Power Control & Safety /
Energy Efficiency / Solar Power

Tel. +90 216 540 71 20-21-22
Fax +90 216 540 71 27
info.tr@socomec.com

UNITED KINGDOM

Critical Power

Tel. +44 1285 863 300
Fax +44 1285 862 304
info.ups.uk@socomec.com

Power Control & Safety / Energy Efficiency

Tel. +44 1462 440 033
Fax +44 1462 431 143
info.scp.uk@socomec.com

IN ASIA PACIFIC

AUSTRALIA

Critical Power / Power Control & Safety

Tel. +61 2 9325 3900
Fax +61 2 9888 9544
info.ups.au@socomec.com

CHINA

Critical Power / Power Control & Safety /
Energy Efficiency

Tel. +86 21 52 98 95 55
Fax +86 21 62 28 34 68
info.cn@socomec.com

INDIA

Critical Power / Power Control & Safety /
Energy Efficiency / Solar Power

Tel. +91 44 39215400
Fax +91 44 39215450 & 51
info.in@socomec.com

SINGAPORE

Critical Power / Power Control & Safety /
Energy Efficiency

Tel. +65 6506 7600
Fax +65 64 58 7377
info.sg@socomec.com

THAILAND

Critical Power

Tel. +66 2 941 1644 7
Fax +66 2 941 1650
info.ups.th@socomec.com

IN MIDDLE EAST

UNITED ARAB EMIRATES

Critical Power / Power Control & Safety /
Energy Efficiency / Solar Power

Tel. +971 4 29 98 441
Fax +971 4 29 98 449
info.ae@socomec.com

IN AMERICA

USA, CANADA & MEXICO

Power Control & Safety / Energy Efficiency

Tel. +1 617 245 0447
Fax +1 617 245 0437
info.us@socomec.com

OTHER COUNTRIES

NORTH AFRICA

Algeria / Morocco / Tunisia
info.naf@socomec.com

AFRICA

Other countries
info.africa@socomec.com

SOUTH EUROPE

Cyprus / Greece / Israel / Malta
info.se@socomec.com

SOUTH AMERICA

Tel. +34 93 540 75 75
info.es@socomec.com

MORE DETAILS

www.socomec.com/worldwide

HEAD OFFICE

SOCOMECC GROUP

SAS SOCOMECC capital 10 816 800€
R.C.S. Strasbourg B 548 500 149
B.P. 60010 - 1, rue de Westhouse
F-67235 Benfeld Cedex - FRANCE
Tel. +33 3 88 57 41 41
Fax +33 3 88 74 08 00
info.scp.isd@socomec.com

www.socomec.com

YOUR DISTRIBUTOR



ENERGY
SPECIALIST
since 1922

socomec
Innovative Power Solutions