

MagLine | Magnetic length and angle measurement systems

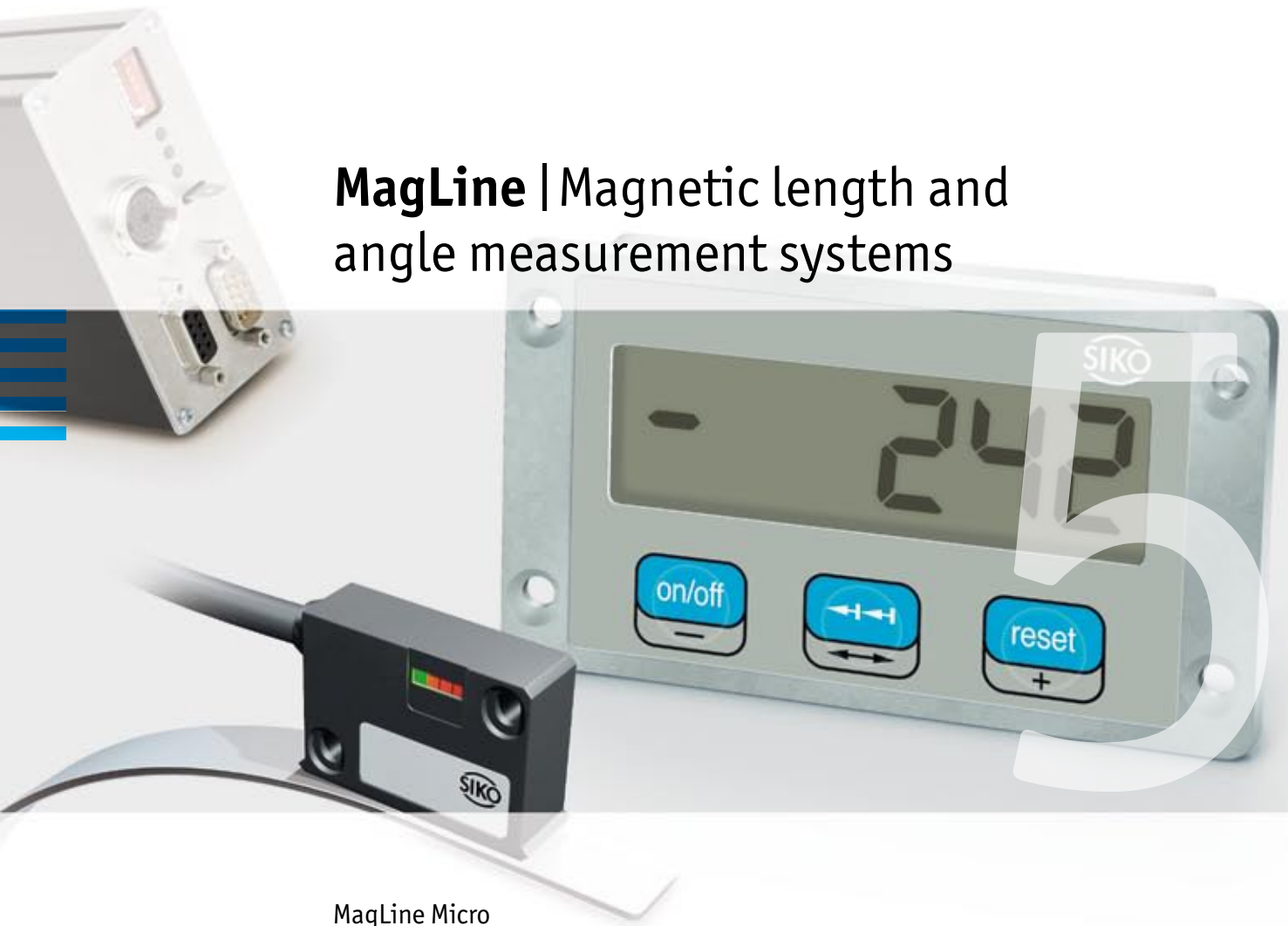

MagLine Micro
MagLine Basic
MagLine Macro
MagLine Roto

Success is the result of a commitment to precision, innovation and customer benefit

“Precision is SIKO’s top priority and standard!” True to this philosophy, SIKO has been developing and producing innovative solutions in distance and angle measurement technology for more than 45 years now. Based in Buchenbach in the foothills of the Black Forest, the company produces its own measurement technologies, which are a global success in all areas of mechanical engineering. Even today, SIKO’s core concept is still manifest in its innovative power, product development and company spirit. Since taking over the business in 1990, industrial engineer Horst Wandres, son of its founder, has continued to develop this philosophy with impressive results.



Intelligent solutions

Attentive ears will always find the right solution. Automation and process optimization are the cornerstones of SIKO’s ambitious new technologies and goal-oriented measurement solutions. The company pursues a clear, consistent line of development, ranging from digital position indicators and handwheels through incremental encoders, absolute encoders and measurement displays to future-oriented technologies with electronically programmable or magnetic measurement systems (MagLine).



Consistent teamwork

The secret of SIKO’s development prowess lies in the motivation and team spirit of its workers. SIKO has a conscious policy of integrating the experiences of its 170 employees, which has a dynamic effect on all areas of company life. Outstanding individual performances blend together to enhance the efficiency of the whole organization.

SIKO again follows the road to success with its compact, ultra-resilient actuators (DriveLine), which enable automated adjustment of machine axles.

Not one for all but all together – this motto typifies SIKO’s synergetic development process, delivering solutions which dominate the market in all aspects of “measurement technology in mechanical engineering”.

This is SIKO today. Precision in motion, dynamic and open for the future ...



6 distinctive product lines

PositionLine	Mechanical and electronic position indicators, handwheels with analog indicators, control knobs
RotoLine	Magnetic and optical encoders, geared potentiometers
LinearLine	Wire-actuated encoders
DriveLine	Actuators
MagLine	Magnetic length and angle measurement systems
DisplayLine	Measurement displays

We speak the same language: At SIKO, a willingness to participate in open dialog enhances engineering performance. Our production site advantages are not interchangeable.



5.0 | MagLine

Product Overview	4
Technical Details	8
Function and Application	11

5.1 MagLine Micro	12
5.2 MagLine Basic	44
5.3 MagLine Macro	110
5.4 MagLine Roto	134
5.5 Accessories	168
5.6 Appendix	182
5.7 Product index, Contact information	188

5.0

5.1

5.2

5.3

5.4

5.5

5.6

5.7

Economical solutions and innovative technologies for industrial applications

The MagLine range is a classic example of SIKO's innovative power. The systems are based on the magnetic measurement principle.

Special benefits of MagLine:

- Completely wear-free
- Insensitive to dust, shavings, humidity, oil, fat, etc.
- Very robust with shock and vibration
- No measurement errors caused by gear ratios or gear backlash
- High system accuracy and reproducibility
- Easy handling and mounting

The challenges faced by measuring devices in extreme industrial conditions make great demands on their reliability and reproducibility. MagLine systems are mainly used for extremely precise tracking of linear and radial positions as well as speeds and angles. The contactless technology demonstrates its advantages in all kinds of applications, such as motor feedback or highly dynamic processes in particularly dirty environments.

Since its introduction, MagLine has undergone continuous further development. Four product families provide a general overview: Micro, Basic and Macro for linear length measurement and Roto for angle and speed measurement.

What is the measurement assignment? The following selection criteria indicate the right MagLine system solution:

- Linear or rotating applications
- Incremental/absolute processes
- System accuracy and reproducibility requirements
- Integration into upstream control systems or independent measuring systems

Featuring a constantly expanding spectrum of components in various specifications, MagLine is designed for a number of special tasks. The technology offers future-oriented, extremely versatile and flexible measuring solutions, which are easily integrated and can be continually extended in line with customers' requirements.

Its easy handling and mounting have won MagLine a reputation as a particularly customer-friendly product line which is universally durable and economical.

Magnetic encoding

The SIKO magnetic bands (flexible steel strips with a magnetic layer) are manufactured precisely and with great care. The bands are equipped with one or more magnetic code tracks in specially developed processes.

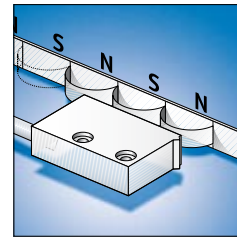

MagLine works in accordance with the principle of contactless scanning of magnetic fields and converts the measured values into digital or analog signals.

The scanning principle is determined by this encoding. Incremental encoding serves for robust and all-round solutions with which, for example, flexible magnetic bands can be individually cut to length before self-adhesive mounting.

The absolute encoding of the band material ensures that the system features a particularly high standard of reproducibility and measuring reliability. Its easy handling and mounting have won MagLine a reputation as a particularly customer-friendly product line, which is universally durable and economical. After power interruptions, for example when the system is switched off and on once more, the actual position value is determined and converted, even if the sensor position has changed in the meantime.

Incremental and absolute encoding methods enable position tracking with different forms of feedback which can be evaluated in various ways (see diagram)

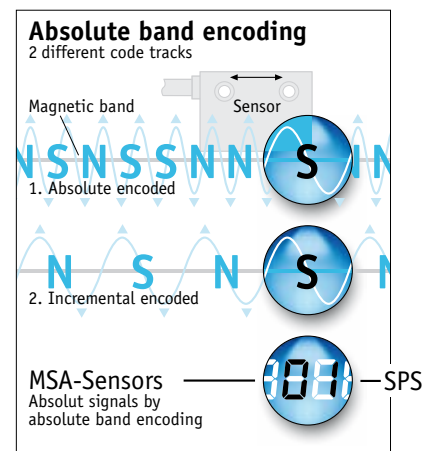
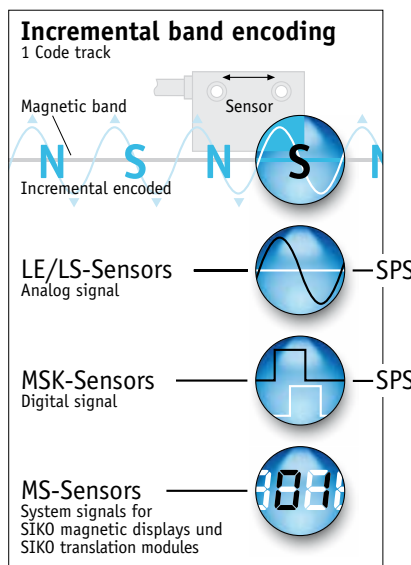

Applications

MagLine systems can be mounted directly on positioning or processing equipment, preventing measurement errors which can occur as the result of gear unit play or spindle tolerances.

The reading distance (sensor/band gap) has a wide tolerance range. This can vary over the whole measuring range and within the defined limits (e.g., due to radial run-out or imprecise guides). Accuracy and reproducibility of the position values are not negatively affected as a result.

The robust measuring equipment is impervious to dirt and mechanical loads in industrial environments. The main advantage is the magnetic measurement method itself, as its principle of operation cannot be negatively affected by typical machine-related effects (vibration, shock), or other influences (bulk solids or fluids).

Demanding conditions require tough equipment. The long service life and durability of the materials and functional units used guarantee maximum reliability. The flexible magnetic bands can also be additionally protected with a stainless steel cover strip to withstand mechanical effects if necessary.

The sensor system itself does not have any moving parts, as the electronics are fully encapsulated. Tough plastic or all-metal housings are generally used for this.

MagLine Micro

This high-resolution linear measuring system was designed for precise and highly-dynamic processes with special requirements regarding measurement in the μm range. The primary applications are in linear and rotary control and drive systems.

With a maximum measuring length of 90 m, MagLine Micro achieves a resolution of $0.2 \mu\text{m}$. All main parameters can be freely selected and enable individual adaptation to site requirements. The measurements made by this sensor-band combination are made available in the form of digital square-wave or analog signals. The measuring ranges can be tracked either incrementally or absolutely.

MagLine Micro systems are an inexpensive alternative to conventional length measurement systems, e.g., using optical methods, yet have a wider range of functional applications due to their robust design and resistance to ambient conditions.

MagLine Micro

Resolution: standard $1 \mu\text{m}$, max. $0.2 \mu\text{m}$
System accuracy $\pm 10 \mu\text{m}$
Repeat accuracy of $\pm 1 \mu\text{m}$
Sensor/band gap max. 0.4 mm

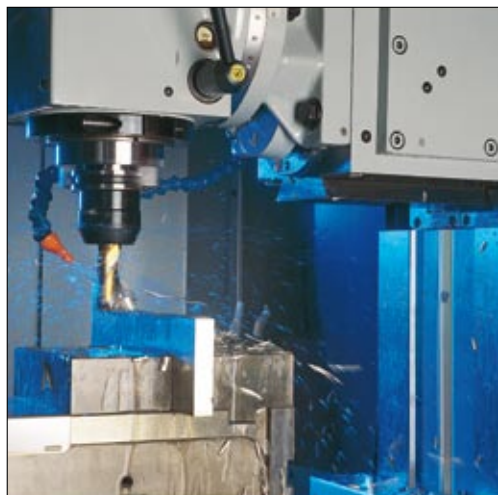

Reliable high-precision measurement and position tracking is still possible even under particularly difficult ambient conditions.

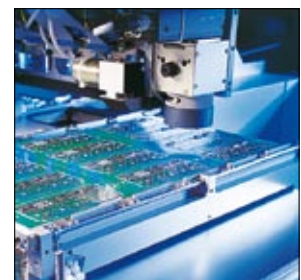

MagLine Basic

Track-proven and mature, the Basic range features an especially wide range of components for incremental or absolute measurement. The system's resolution makes it suitable for measurements right down to the μm range.

Basic is the MagLine product family with the most comprehensive range. It offers economical solutions for industrial applications, which do not require a very high resolution for measuring accuracy. The system is ideal, for example, for applications in the wood, metal or stone processing industries and also for machines for glass and plastic processing.

Applications using Basic components benefit from its precise, robust measuring methods and matching sensors, with and without integrated translation module.

The versatility of this range is also demonstrated in a series of ready-to-use products. The sensor-display combinations are ready to be fitted with the appropriate self-adhesive band and installed at the desired measuring point. A reliable measuring system can therefore be simply mounted, for example for the length limit stops on a saw.

All measured values can be displayed directly or converted by other controllers for further processing. The Basic series also features interfaces for integration into almost any industrial environment.

MagLine Basic

Resolution: standard $10\ \mu\text{m}$, max. $1\ \mu\text{m}$
System accuracy $\pm 25\ \mu\text{m}$
Repeat accuracy $\pm 10\ \mu\text{m}$
Sensor/band gap max. $2\ \text{mm}$

5.0



Incremental and absolute position tracking with compatible electronics for connection to controllers or for direct on-site indication.



FELDER KG, Austria



Wilhelm Attendorf GmbH & Co. KG

MagLine Macro

Macro is specially designed for very long distances with both absolute and incremental measurement. The systems provide a reading distance of up to 20 mm, e.g., to compensate for height variations, and accuracy data also designed for particularly long tracking paths e.g., in storage and conveying technology.

Standardized interfaces allow problem-free integration in controls. Central setting and monitoring is, for example, particularly important in stage and studio applications. MagLine Macro ensures reliable position tracking down to the last millimeter with the complex interaction of a number of moving units.

MagLine Macro

Resolution: standard 1 mm, max. 0.25 mm

System accuracy ± 1 mm

Repeat accuracy of ± 1 mm

Sensor/band gap max. 20 mm

As the sensors are fully encapsulated, MagLine Macro is suitable for use in extreme conditions such as stone processing. The advantages of the high protection category (IP67) and its resistance to even extremely dirty conditions are fully revealed in such applications.

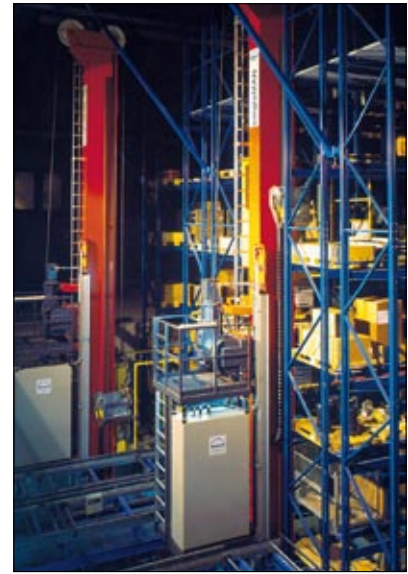

The compact design of the scale and corresponding sensors permits simple and inconspicuous integration into almost any guide unit.



5.0



MagLine Roto

The Roto range is an ideal alternative to conventional optical encoder systems, especially when exact speed or angle measurement is required under difficult ambient conditions such as on balancing machines. The system even runs reliably in an oil bath, for example in a hydraulic pump.

Durability is also a feature of the Roto principle: The contactless measuring principle is also advantageous for elevators, as the extreme mechanical stresses in long-term operation are not transmitted to the measuring system.

MagLine Roto

Max. resolution 200 000 pulses/revolution

System accuracy $\pm 0.1^\circ$

Repeat accuracy of ± 1 increment

Sensor/band gap max. 2 mm



Extremely robust and designed for direct angle and speed measurement – the typical applications of MagLine Roto profit in more ways than one from the contactless magnetic measuring processes.

The magnetic measurement principle

The core element of magnetic linear measurement is a permanently mounted magnetic band (also called the scale). This band is scanned by a magnetic sensor which forwards the information either to an electronic evaluation system, a higher-level controller (PLC) or directly to a connected magnetic display.

The actual magnetic linear measurement is based on the changes in resistance by magnetic effects. The magnetic bands used are encoded by SIKO in specially developed processes.

These encoded scales are scanned by contactless sensors. The integrated electronic system converts the measured values into digital or analog signals for further processing, for example by controllers or a corresponding SIKO indicator.

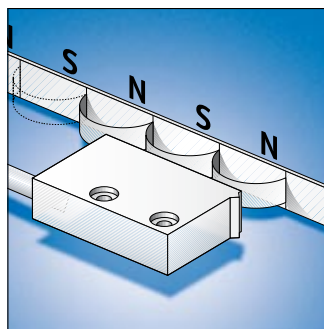

A sensor registers the magnetically encoded path information and converts this to standardized interface signals for subsequent processing.

5.0

Incremental and absolute processes – the difference

Magnetic linear measurement is performed either incrementally, quasi-absolutely or true-absolutely.

Incremental method

In incremental systems the magnetic band is magnetized at regular intervals with north and south poles, and the pole length also determines the maximum resolution and system accuracy. If the sensor is moved over the band, the periods generate the path information which is processed in the form of square-wave signals (counting pulses). Counting of the pulses provides information on the traveled path.

In an incremental system at least one absolute reference is necessary – the so-called reference point. This point serves for re-orientation of the system and can be stored on the magnetic band as additional information. This reference point is also of importance due to the fact that the actual position value is generally lost in an incremental system if the power supply is interrupted (e.g., if the system is switched on and off) and if the sensor position has been changed in the meantime. A new referencing operation is then necessary.

Incremental to absolute measurement

The system requires re-referencing if ...

Scanning method	Band type	Power interruption	Sensor/band reading distance exceeded
■ incremental		yes	yes
■ quasi-absolute		no	yes
■ true-absolute		no	no

- A “quasi-absolute” measurement is achieved by buffering the measured data by means of a battery. Movement of the sensor along an incrementally encoded band is recognized even in a currentless state. Referencing is only necessary if the sensor exceeds the maximum band distance.
- A “true-absolute” measurement is achieved when the magnetic strip is encoded absolutely, thus enabling all currentless movements of the sensor/band to receive an absolute position signal direct from the magnetic band when the system is switched on.



The quasi-absolute method

This method is based on incremental measuring methods. The measured values are buffered in a system-related electronic evaluation unit so that they are available as absolute values. An integrated battery ensures that currentless motion is also recognized. The specially developed lowest-power technology enables reliable operation for up to 10 years without changing the battery.

When installing battery-buffered systems, the prescribed maximum reading distance between the sensor/band must not be exceeded, otherwise measurement information can be lost even with this method. If this is the case, a reference operation is necessary.

The true-absolute method

Reference operations are not necessary for linear measurement with absolute encoded magnetic strips. The flexible plastic strip is magnetized with a special absolute code. Commissioning is performed by one-time alignment and calibration of the system. Due to the absolute encoding of the band, no buffer battery is necessary and the current position value is immediately available when the system is switched on.

Even a change in position in a non-powered condition does not affect the accuracy of the displayed measured value, because the position is stored at each point on the encoded magnetic strip. A reference operation is also unnecessary, for example, if the sensor is lifted from the magnetic band for maintenance purposes.



In summary

Each of the measuring methods described above has its advantages. A decision on whether an incremental process is preferable for economic reasons or the absolute process for time and safety reasons can be made once the details of the respective system and application are known.

Path and angle measurement is a standard assignment in mechanical and plant engineering. The SIKO MagLine products have been in use for many years with modern, track-proven solutions. Irrespective of whether an incremental or absolute process is employed, the contactless measuring principle is by far superior in many applications to conventional solutions such as rotary encoders with rack and pinions, wire-actuated encoders or optical systems due to its extreme robustness.

When measurement is required over long distances with a high degree of accuracy and simple handling, MagLine is always an economical solution for a number of tasks. All standard interfaces for connection to control, regulation and bus systems are available.

Incremental systems: Reference signals of sensors and magnetic bands

1. A **sensor with the code "0"** (without index) is only equipped with one sensor element which measures length. A sensor version without index runs, for example, with MB500 incremental (one track).
2. A **sensor with the code "I"** (index signal) is also only equipped with one sensor element which measures length. With an additional electronic system an index signal is generated by the sensor for each period. A second track on the band is not necessary to generate such a signal. This sensor type therefore also runs with MB500 incremental (one track).
3. A **sensor with the code "R/RB"** (one-time or periodical reference point) is equipped with an additional sensor element which scans a second track parallel to the first track on the band. MB500 (2 tracks) with reference point code E (once) or P (periodically) is used, for example, for this sensor. In addition the position of the reference signal on the band must be determined (refer to the data sheet of the respective magnetic band).

5.0

Options for referencing an incremental system

1. You are using a system comprising a sensor without reference signal and a magnetic band with one track

The system can be either referenced by moving to a defined position – e.g., a stop block – or by linking a certain position with an external encoder (limit switch, light barrier, etc.). Problem: Depending on the version of the stop block or the external encoder, the repeat accuracy of this method is insufficient.

2. You are using a system comprising a sensor with the index signal "I" and a magnetic band with one track

With this version you link an external encoder (limit switch, light barrier, etc.) with an index signal which the sensor emits with each magnetic period. The only function of the external encoder is to determine the correct period. The accuracy of referencing corresponds to the repeat accuracy of the sensor (refer to the respective sensor data sheet). The following must be observed:

- Referencing can be performed at any point of the traveling path.
- The switching path of the external encoder must be shorter than that of the distance between the index pulses.
Note: On the MB500 the index pulse distance is 5 mm, on the MB100 only 1 mm.

Diagram to sections 1./2.

If a **sensor** has the **code I/0**, it works with ...

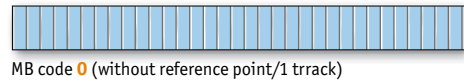
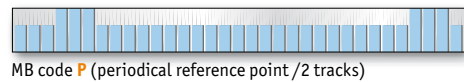
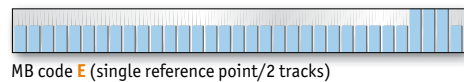

Diagram to sections 3.

If a **sensor** has the **code R/RB**, it works with ...



3. You are using a system comprising a sensor with the reference signal "R/RB" and a magnetic band with two tracks (one-time/periodical reference point, magnetized on the second track)

On this version an external encoder is normally not necessary, referencing is only performed with the reference signal of the sensor. Realignment can only be performed at the point at which a corresponding reference point is magnetized onto the band.

With long measurement distances, it is recommended to work with periodical reference points if necessary and to identify these with external encoders. Referencing is performed with the repeat accuracy of the sensor (refer to the respective sensor data sheet).

Sensor with code **I** without reference point/1 track

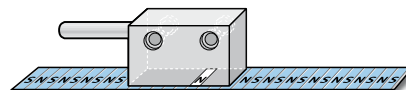

Sensor with codew **R/RB** with 1 or x reference point(s)/2 tracks

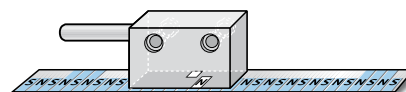

Environmental conditions	Examples of use	Benefits
--------------------------	-----------------	----------

MagLine Micro
max. resolution 0.2 μm

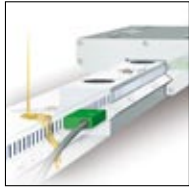

This system is impervious to outside influences, and the system provides extremely high resolutions.



- High resolution
- Incremental/absolute

E.g., linear drives with dowel drilling systems, parquet manufacture, tubular film packaging ...

MagLine Basic
max. resolution 1 μm



Unshakeable all-rounder with a number of incremental and absolute components. The special feature: Ready-to-use solutions with indicators and connected sensor.

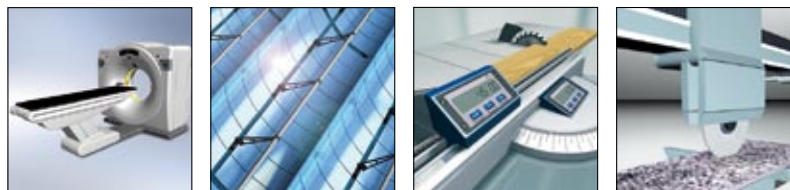

- Versatile system
- Easy mounting
- Ideal for retrofitting

E.g., CT patient tables, mirror adjustment (solar power plants), sliding table saws, stone cutting ...

MagLine Macro
max. resolution 0.25 mm



Especially height-tolerant magnetic measurement system with sensor/band gap of max. 20 mm; therefore, ideally suited for extreme applications (stone processing).

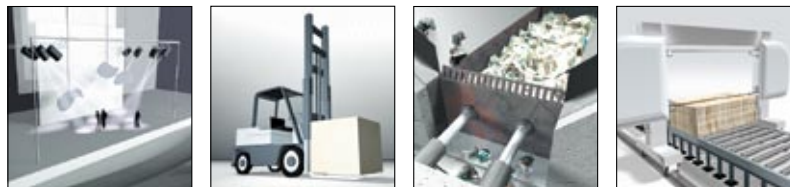

- High resolution with very long measurement paths
- High protection category (IP67)

E.g., stage technology, forklifts, waste and scrap presses, stone cutting ...

MagLine Roto
max. resolution 0.001°



Roto enables particularly durable angle or speed management, as the contactless measuring method physically separates the Roto sensor from the band or ring.

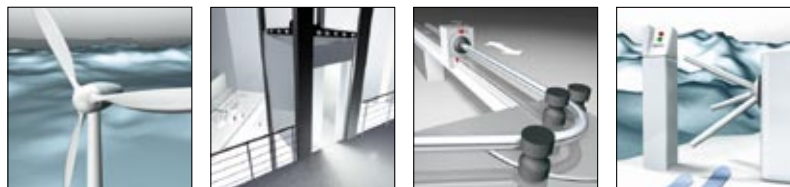

- High operational safety
- Long service life
- High protection category (IP67)

E.g., wind energy plants, elevator technology, tube bending technology, access control ...

5.0

μm 5.1

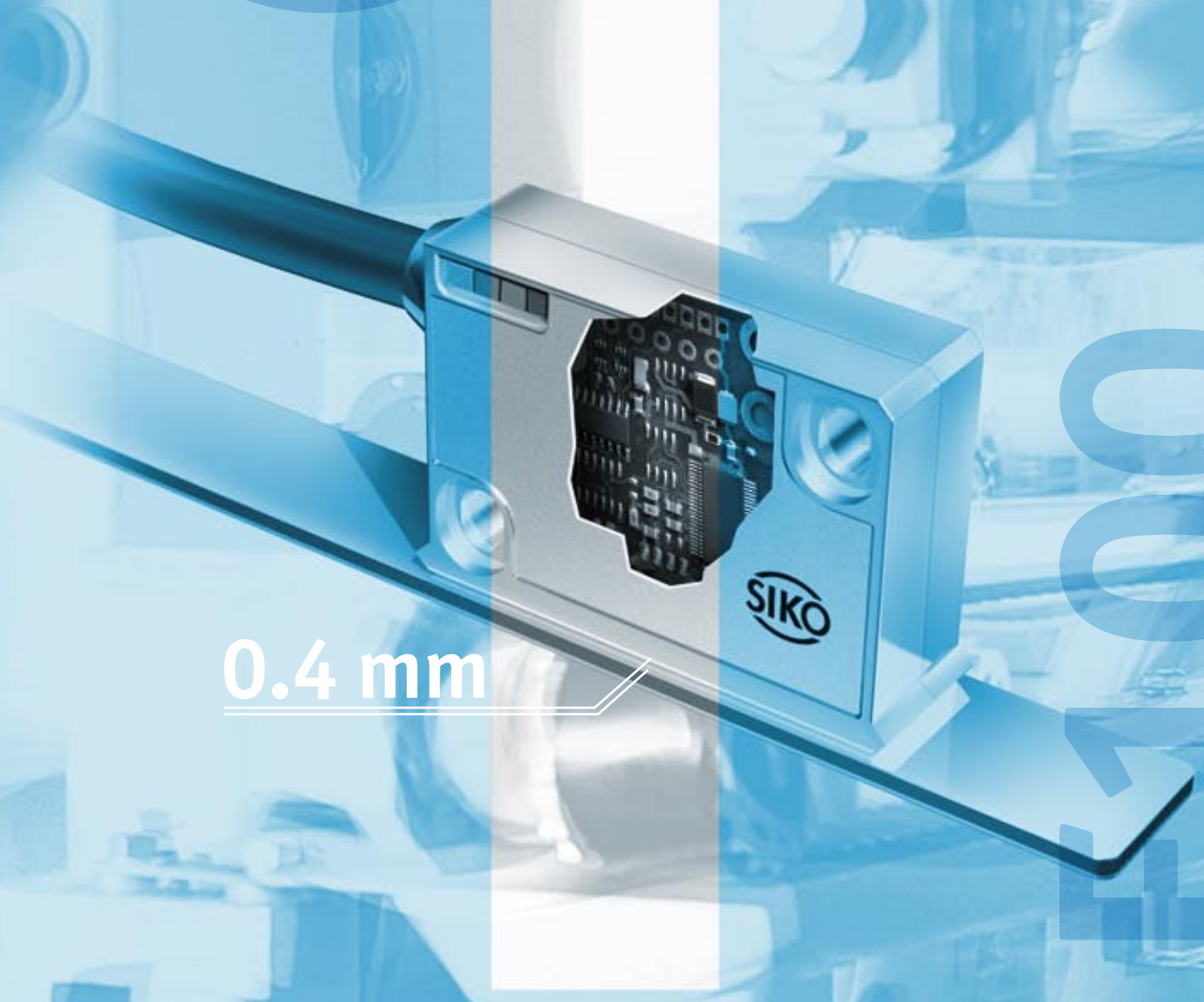

0.4 mm

400

5.0 | MagLine Product Overview 3

5.1 | MagLine Micro

Short Description, Technical Details		14
Product Matrix		15
Products		
incremental	MB100	16
	MSK1000	18
	MSK1100	22
	LE100/1	26
	LS100	29
	MS100/1	32
absolute	MA100/2	34
	MBA111	36
	MSA111	38
	AEA111/1	41

5.2 | MagLine Basic 44

5.3 | MagLine Macro 110

5.4 | MagLine Roto 134

5.5 | Accessories 168

5.6 | Appendix 182

5.7 | Product index, Contact information 188

5.0

5.1

5.2

5.3

5.4

5.5

5.6

5.7

Introduction

The MagLine Micro operates in the μm range and was especially designed for precise and highly dynamic processes on linear and rotary guide and drive systems with their high demands regarding value tracking. With its very high-resolution magnetic measurement the MagLine Micro is available as either an incremental or absolute scanning system with configurable resolutions of up to $0.2 \mu\text{m}$ and a measuring accuracy of up to $10 \mu\text{m}$.

- Incremental and absolute measurement method
- Max. resolution $0.2 \mu\text{m}$
- Repeat accuracy max. $1 \mu\text{m}$
- Accuracy class up to $10 \mu\text{m}$

Product Matrix for the overall system

Whether you need a new system or are retrofitting an existing system – with its simple handling and installation the contactless measuring system can also be integrated into existing measuring environments. With MagLine Micro you combine fully coordinated components such as sensor, magnetic band and display or electronic evaluation system to create a complete system which is unsurpassed when it comes to wear-free operation, robustness and economy.



Magnetic bands

Measuring length up to 90 m
Accuracy class up to $10 \mu\text{m}$

Sensors

Analog interface 1 V_{SS}
Maximum tolerance of reading distance to scale 0.4 mm

Translation module

Real-time signal processing
Resolution $0.2 \mu\text{m}$

Magnetic displays

Direct display
Resolution and repeat accuracy up to $1 \mu\text{m}$

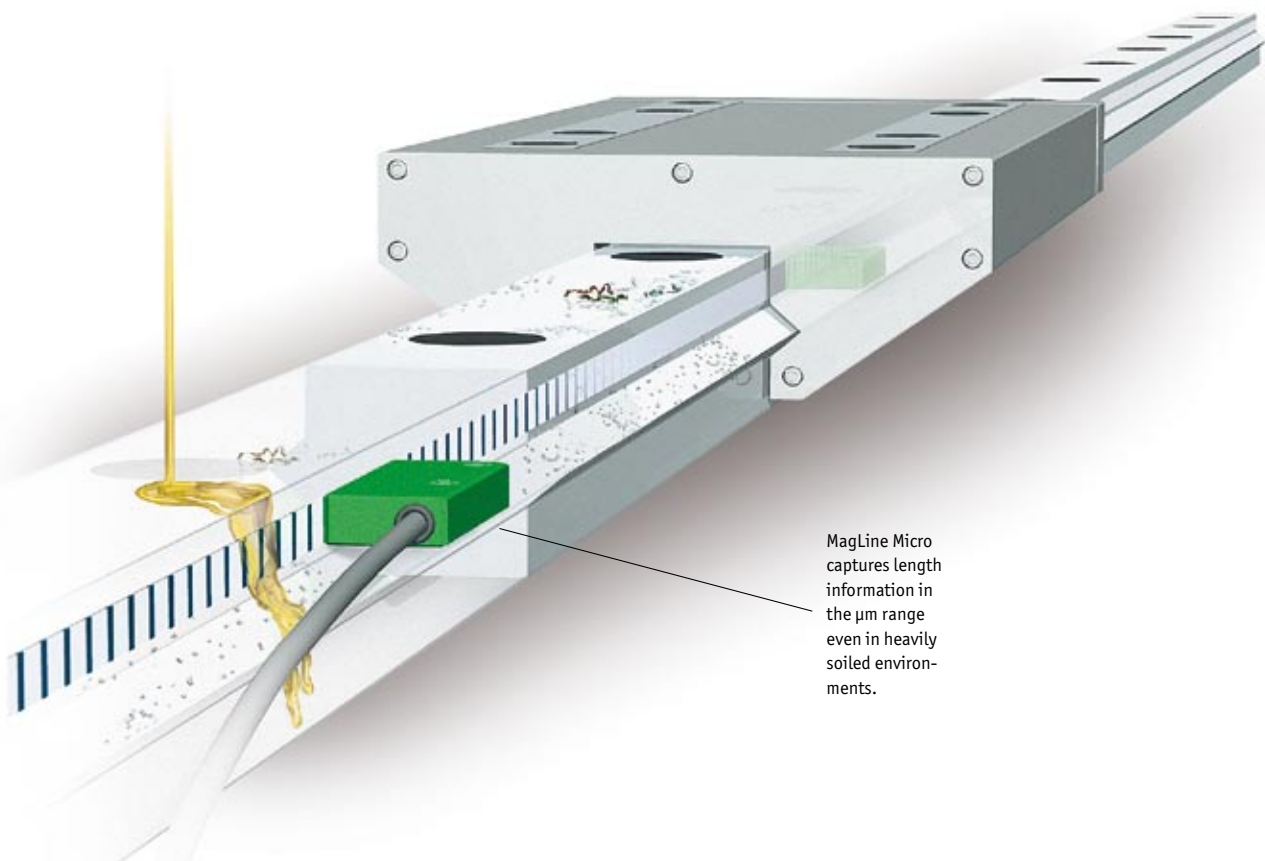

MagLine Micro captures length information in the μm range even in heavily soiled environments.

MagLine Micro

Signal analysis via	Incremental systems				Absolute systems	
	Output, digital	Output, analog	Magnetic display	Translation module	Translation module	Translation module
System accuracy class (μm)	± 10	± 10	± 10	± 10	± 10	± 10
Maximum repeat accuracy (μm)	± 1	± 1	*)	*)	± 1	± 1
Maximum measurement length/magnetic display (m)	infinite	infinite	infinite	infinite	$\pm 9.999.999$	4.0
Maximum reading distance (mm)	0.4	0.4	0.4	0.4	0.4	0.2

Resolution max. in μm	Supply voltage	Output/ interface	Magnetic sensor	Page					
0.2	6.5 ... 30 V DC 4.75 ... 6 V DC	LD	MSK1000	18					
0.2	6.5 ... 30 V DC 4.75 ... 6 V DC	LD	MSK1100	22					
*)	10.5 ... 30 V DC 5 V DC	1 V _{SS}	LE100/1	26					
*)	24 V DC 5 V DC	1 V _{SS}	LS100	29					
*)	feed via down-stream electronics unit	—	MS100/1	32					
1	feed via down-stream electronics unit	1 V _{SS}	MSA111	38					

					Magnetic display				
1	24 V DC 230 V AC 115 V AC	RS232, RS485	MA100/2	34					

					Translation module				
1	24 V DC	1 V _{SS} , SSI RS485	AEA111/1	41					

Width in mm	Accuracy class in μm	Available length max. in m/ piece	Magnetic band	Page					
5 or 10	10 or 50	4 (10 μm) 90 (50 μm)	MB100	16					
10	10	4.07	MBA111	36					

*) depends on the downstream electronics

Magnetic Band MB100

Incrementally coded scale, 1 mm pole length

Profile

- Easy adhesive mounting, self-assembly possible
- Reels up to 90 m available
- 1 mm pole length
- System accuracy up to 10 μm

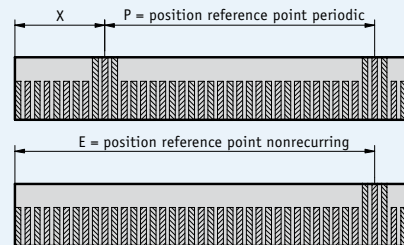
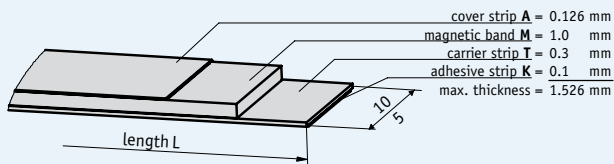

Reference points (all details in mm)

X	0.02
P	0.02, 0.06, 0.1, 0.14, 0.18, 0.22, 0.26, 0.34, 0.42, 0.5
E	0.02, 0.08, 0.14, 0.2, 0.26, 0.32, 0.38, 0.44, 0.5

Mechanical data

Feature	Technical data	Additional information
Pole length	1 mm	
Measuring length	infinite	
Band width	10 mm or 5 mm	
Thickness	1.4 mm	without cover strip
Accuracy class	10 μm or 50 μm	
Temperature coefficient	$(11 \pm 1) \times 10^{-6}/\text{K}$ $(16 \pm 1) \times 10^{-6}/\text{K}$	spring steel stainless steel
Operating temperature	-20 ... +70 °C	
Storage temperature	-40 ... +70 °C	
Humidity	100 % rh	condensation permitted
Mounting type	glued joint	pre-assembled double-sided adhesive strip
Cover strip material	stainless steel	

Order

The necessary band length is calculated as follows:
 Measured path + sensor length "S" + (2 x lead-in and lead-out "B"). Sensor length "S" refer to the drawing of the employed sensor, lead-in and lead-out "B" = 10 mm.

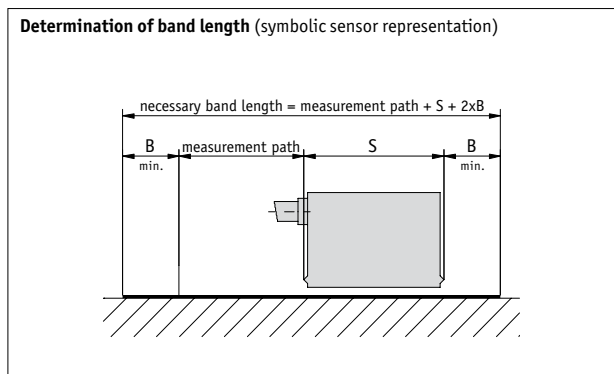

Order table

Feature	Order data	Specifications	Additional information
Width	10	A in mm	
	5	A in mm	
Accuracy class	0.01	B 0.01 mm	available length: max. 4000 mm
	0.05	B 0.05 mm	available length: max. 90000 mm
Length	...	C 0.1 ... 90 m, in steps of 0.1 m	Order information, see "Determination of band length" measurement + sensor length 2 x B
Carrier strip	St	D steel	
	VA	D stainless steel	only with width 10 mm
Adhesive carrier strip	TM	E with	
	TO	E without	
Cover strip	AM	F with	stainless steel
	AO	F without	
Reference point	O	G without	
	E	G one-time	only with width 10 mm
	P	G periodic	only with width 10 mm
Position of reference point E one-time	...	H 0.02, 0.06, 0.1, 0.14, 0.18, 0.22, 0.26, 0.34, 0.42, 0.5 others on request	indicate only if reference point E was selected
or Position of reference point P periodic	...	H 0.02, 0.08, 0.14, 0.2, 0.26, 0.32, 0.38, 0.44, 0.5 others on request	indicate only if reference point P was selected

Order code

MB100 - - - - - - - -

A B C D E F G H

Scope of delivery: MB100, User information

Additional information:

Short Description, Technical Details
 Product Overview

Page 14 cont.
 Page 4 cont.

Profile

- Max. resolution 0.2 μm
- Repeat accuracy $\pm 1 \mu\text{m}$
- Max. sensor/band reading distance 0.4 mm
- Status LED display
- Robust metal housing



5.1

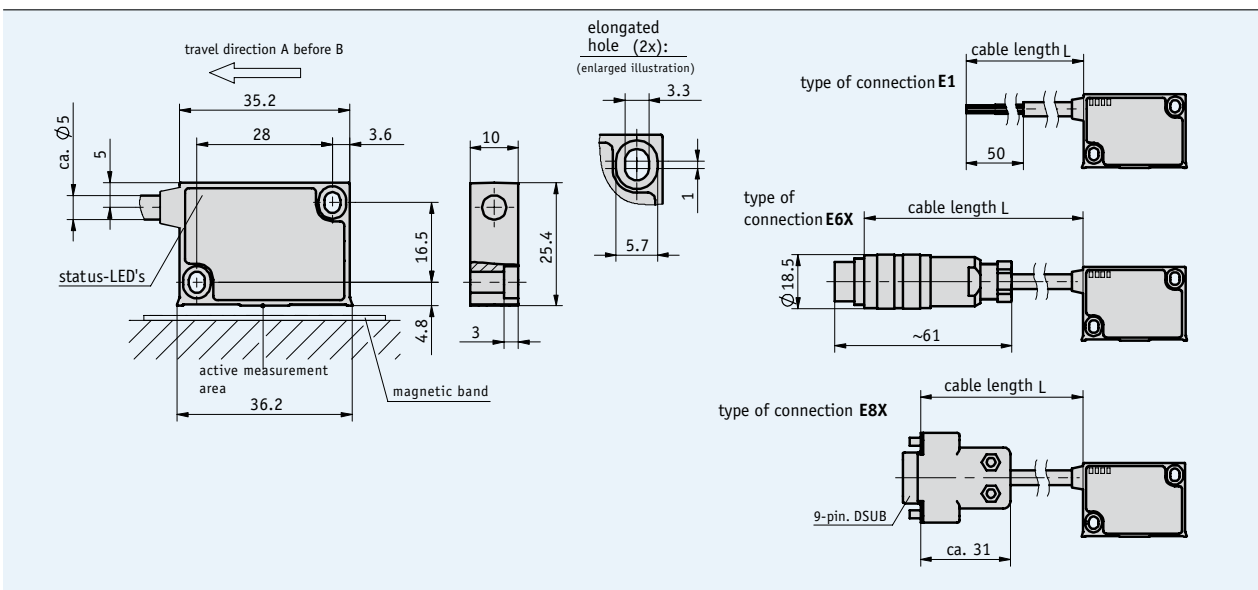

Mechanical data

Feature	Technical data	Additional information
Scale embodiment	MB100	
System accuracy	$\pm 10 \mu\text{m}$	accuracy class 10 μm with MB100
Repeat accuracy	max. $\pm 1 \mu\text{m}$	
Sensor/band reading distance	0.1 ... 0.4 mm 0.1 ... 0.2 mm	with reference signals O, I with reference signal RB
Travel speed	depends on resolution and pulse interval	see table
Housing	zinc die-cast	aluminum front cover, anodized blue
Sensor cable	PUR	drag chain-compatible
Operating temperature	-10 ... +70 °C	
Storage temperature	-30 ... +80 °C	
Humidity	100 % rh	condensation permitted
Protection category	IP67	
Vibration resistance	10 g/50 Hz	
Max. measuring length	infinite	in steps of 90 m

Travel speed

Resolution (μm)	Travel speed V_{max} (m/s)				
	0.2	1	2	5	
0.2	0.64	3.20	6.40	16.00	0.08
1	0.32	1.60	3.20	8.00	0.40
2	0.16	0.80	1.60	4.00	0.80
5	0.08	0.40	0.80	2.00	2.00
Pulse interval (μs)	0.25	0.50	1.00	2.00	
Counting frequency (kHz)	1000.00	500.00	250.00	125.00	

Electrical data

Feature	Technical data	Additional information
Operating voltage	6.5 V DC ... 30 V DC 4.75 V DC ... 6 V DC	reverse-polarity protection on UB no reverse-polarity protection on UB
Current consumption	<25 mA	without load
Type of connection	flying leads round connector D-SUB 9-pin	
Output circuit	LD, RS422	
Output signals	A, /A, B, /B, I, /I, or R, /R	
Pulse width of reference signal	1 or 4 increments	
Resolution	0.2, 1, 2, 5 μm	
Interference protection class	3	IEC-61000-6-2
Real-time requirement	real-time signal processing	
Signal level high	>2.5 V	
Signal level low	<0.5 V	

5.1

Signal forms

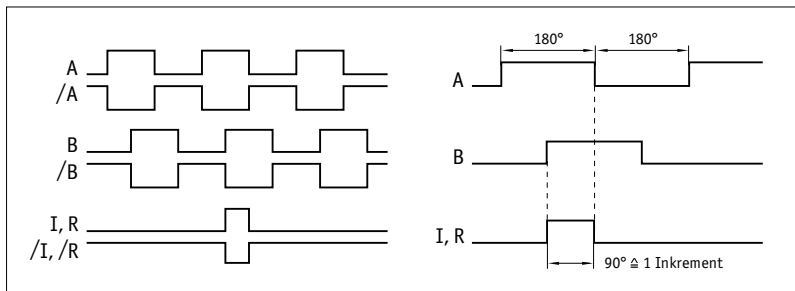

! The logical condition of signals A and B is not defined in reference to the index signal I or the reference signal R. It can deviate from the signal form.

Pulse interval

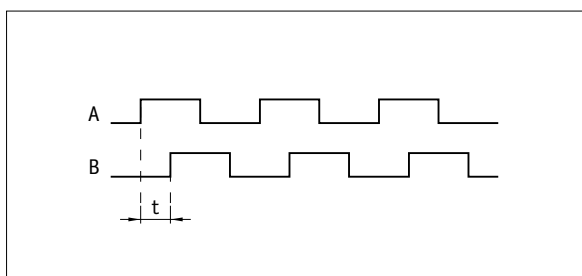

Example: Pulse interval $t = 1 \mu s$
(i.e., the downstream unit must be able to process 250 kHz)

$$\text{Formula for input frequency} = \frac{1}{1 \mu s \times 4} = 250 \text{ kHz}$$

Pin assignment

■ without index signal

Signal	E1	E6X	E8X
A	red	1	1
B	orange	2	2
+UB	brown	4	4
GND	black	5	5
/A	yellow	6	6
/B	green	7	7
N.C.		3	3, 8, 9

■ with index signal

Signal	E1	E6X	E8X
A	red	1	1
B	orange	2	2
I, R	blue	3	3
+UB	brown	4	4
GND	black	5	5
/A	yellow	6	6
/B	green	7	7
/I, /R	violet	8	8
N.C.			9

Mounting note

On systems with reference points on the magnetic band, please ensure the correct alignment of the sensor and band (see diagram).

Reference signal		O, I	RB
Sensor/band reading distance A		max. 0.4 mm	max. 0.2 mm
Lateral offset B		max. ±2 mm	max. ±0.5 mm

Sensor/band reading distance (symbolic sensor representation)

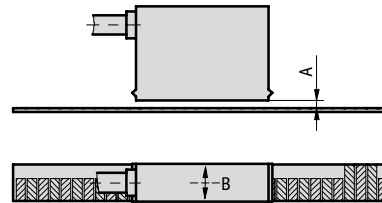

Order

Order note

The internal translation module can generate fast counting pulses. The pulse length is limited by the pulse interval. The follow-up electronic system must be coordinated accordingly, if necessary select the pulse interval previously.

Order table

Feature	Order data	Specifications	Additional information
Operating voltage	10	6.5 ... 30 V DC	
	11	4.75 ... 6 V DC	
Type of connection	E1	flying leads, 2 m cable	
	E6X	round connector without mating connectors	
	E8X	D-SUB 9-pin without mating connectors	
		cable extensions on request	
Cable length L	...	1 ... 20 m, in steps of 1 m	
Reference signal	0	without	
	I	index periodic	
	RB	fixed reference, scanning on band side	
Resolution in μm	...	0.2, 1, 2, 5	
Pulse interval in μs	...	0.25, 0.5, 1, 2 others on request	

Order code

MSK1000 - - - - - -
A B C D E F

Scope of delivery: MSK1000, User information, Allen fastening screws M3 x 14 mm ISO 4762, lock washers M3 DIN 7980, strain relief for sensor cable, distance gage 0.2 mm

Additional information:

Short Description, Technical Details
Product Overview

Page 14 cont.
Page 4 cont.

Profile

- Max. resolution up to 0.2 μm
- Repeat accuracy of ±1 μm
- Max. sensor/band reading distance 0.4 mm
- Status LED display
- Robust metal housing
- Two integrated limit switches, lateral scanning



5.1

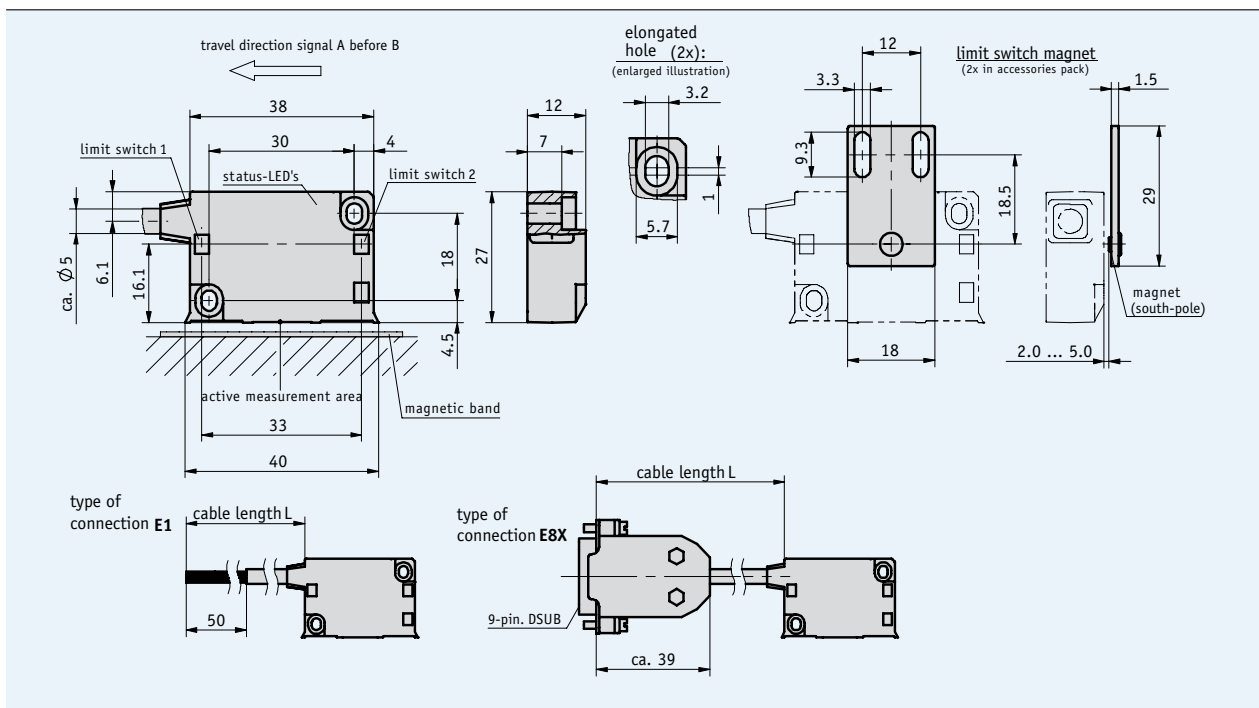

Mechanical data

Feature	Technical data	Additional information
Scale embodiment	MB100	
System accuracy	±10 μm	
Repeat accuracy	max. ±1 μm	
Sensor/band reading distance	0.1 ... 0.4 mm 0.1 ... 0.2 mm	with reference signals 0, I with reference signal RB
Travel speed	depends on resolution and pulse interval	see table
Housing	zinc die-cast	aluminum front cover, anodized blue
Sensor cable	PUR	drag chain-compatible
Operating temperature	-10 ... +70 °C	
Storage temperature	-30 ... +80 °C	
Humidity	100 % rh	condensation permitted
Protection category	IP67	
Vibration resistance	10 g/50 Hz	
Max. measuring length	infinite	in steps of 90 m

Travel speed

Resolution (μm)	Travel speed V max. (m/s)				
	0.2	0.64	0.32	0.16	0.08
1	3.20	1.60	0.80	0.40	0.40
2	6.40	3.20	1.60	0.80	0.80
5	16.00	8.00	4.00	2.00	2.00
Pulse interval (μs)	0.25	0.50	1.00	2.00	2.00
Count. frequency(kHz)	1000.00	500.00	250.00	125.00	125.00

Electrical data

Feature	Technical data	Additional information
Operating voltage	6.5 V DC ... 30 V DC 4.75 V DC ... 6 V DC	reverse-polarity protection on UB no reverse-polarity protection on UB
Current consumption	<25 mA	without load
Type of connection	flying leads D-SUB 15-pin	
Output circuit	LD, RS422	
Output signals	A, /A, B, /B, I, /I, or R, /R	
Pulse width of reference signal	1 or 4 increments	
Resolution	0.2, 1, 2, 5 μm	
Interference protection class	3	IEC-61000-6-2
Real-time requirement	real-time signal processing	
Signal level high	>2.5 V	
Signal level low	<0.5 V	

5.1

Signal forms

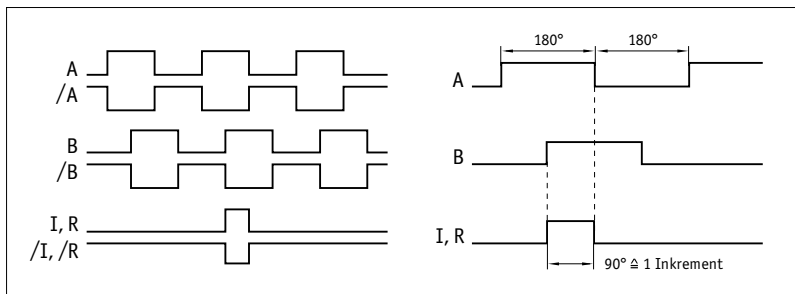

! The logical condition of signals A and B is not defined in reference to the index signal I or the reference signal R. It can deviate from the signal form.

Pulse interval

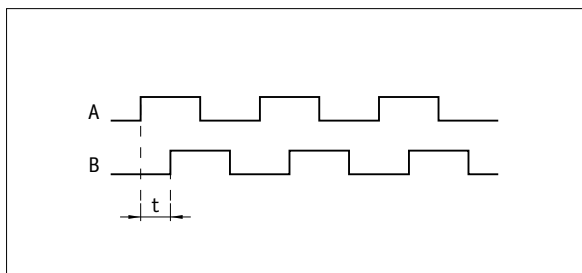

Example: Pulse interval t = 1 μs
(i.e., the downstream system must be able to process 250 kHz)

$$\text{Formula for counting frequency} = \frac{1}{1 \mu\text{s} \times 4} = 250 \text{ kHz}$$

Pin assignment

■ **without index signal**

signal	E1	E8X
L1	blue	1
L2	violet	2
/B	green	5
B	orange	6
A	red	7
/A	yellow	8
GND	black	10
+UB	brown	12
Screen		14
N.C.		3,4,9,11,13,15

■ **with index signal**

signal	E1	E8X
L1	gray	1
L2	white	2
/I, /R	violet	3
I, R	blue	4
/B	green	5
B	orange	6
A	red	7
/A	yellow	8
GND	black	10
+UB	brown	12
Screen		14
N.C.		9,11,13,15

Mounting instruction

On systems with reference points on the magnetic band, please ensure the correct alignment of the sensor and band (see diagram).

Reference signal	O, I	RB
Sensor/band reading distance A	max. 0.4 mm	max. 0.2 mm
Lateral offset B	max. ±2 mm	max. ±0.5 mm

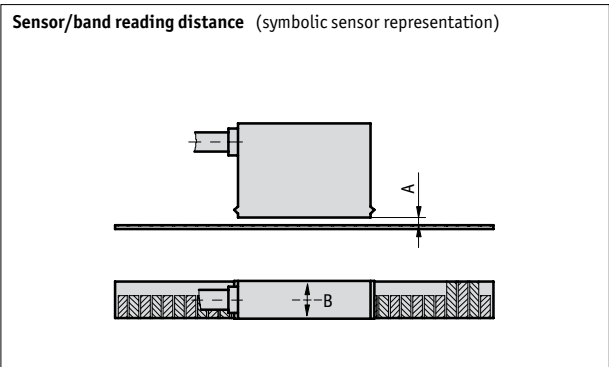

Order

Order note

The internal translation module can generate fast counting pulses. The pulse length is limited by the pulse interval. The follow-up electronic system must be coordinated accordingly; if necessary, select the pulse interval previously.

Order table

Feature	Order data	Specifications	Additional information
Operating voltage	10	6.5 ... 30 V DC	
	11	4.75 ... 6 V DC	
Type of connection	E1	flying leads	
	E8X	D-SUB 15-pin without mating connectors cable extensions on request	
Cable length L	...	1 ... 20 m, in steps of 1 m	
Reference signal	0	without	
	I	index periodic	
	RB	fixed reference, scanning on band side	
Resolution in μm	...	0.2, 1, 2, 5	
Pulse interval in μs	...	0.25, 0.5, 1, 2	

Order code

MSK1100 - - - - - -
A B C D E F

Scope of delivery: MSK1100, User information, Allen fastening screws M3 x 14 mm ISO 4762, lock washers M3 DIN 7980, strain relief for sensor cable, distance gage 0.2 mm, 2x release magnets for limit switch

Additional information:

Short Description, Technical Details
Product Overview

Page 14 cont.
Page 4 cont.

Profile

- Repeat accuracy max. $\pm 1 \mu\text{m}$
- Output circuit sin/cos 1 V_{SS}
- Signal period 1 mm
- Status LED display
- Robust metal housing

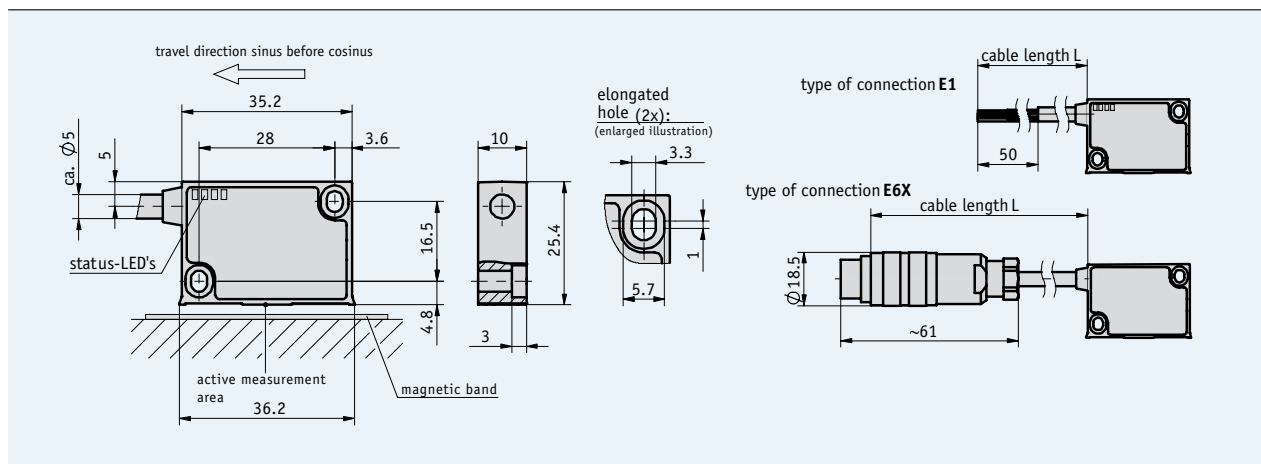

Mechanical data

Feature	Technical data	Additional information
Scale embodiment	MB100	
System accuracy	$\pm 10 \mu\text{m}$	accuracy class $10 \mu\text{m}$ only with MB100
Repeat accuracy	max. $\pm 1 \mu\text{m}$	
Sensor/band reading distance	0.1 ... 0.4 mm 0.1 ... 0.2 mm	with reference signal O, IA, ID with reference signal RB, RD
Travel speed	max. 20 m/s	5 m/s with reference signal RB
Housing	zinc die-cast	
Sensor cable	PUR	drag chain-compatible
Operating temperature	$-10 \dots +70 \text{ }^\circ\text{C}$	
Storage temperature	$-30 \dots +80 \text{ }^\circ\text{C}$	
Humidity	100 % rh	condensation permitted
Protection category	IP67	
Vibration resistance	$<200 \text{ m/s}^2$ (50 ... 2000 Hz)	
Max. measuring length	infinite	in steps of 90 m

Electrical data

Feature	Technical data	Additional information
Operating voltage	10.5 ... 30 V DC 5 V DC ±5 %	reverse-polarity protection on UB no reverse-polarity protection on UB
Current consumption	<25 mA <50 mA	with 24 V with 5 V
Type of connection	flying leads round connector	
Output circuit	1 V _{SS}	
Output signals	sin, cos, /sin, /cos, I, /I, or R, /R	
Pulse width of reference signal	see the drawing of the signal shape	
Interference protection class	3	according to IEC 801
Real-time requirement	real-time signal processing	
Signal amplitude	1 V _{SS} ±10 %	at 0-70 °C with RA = 120 Ohm to 1 kOhm
Output impedance	0 Ohm (Rload >75 Ohm), short-circuit-proof	
Offset sine/cosine	2.5 V ±100 mV UB/2 ±100 mV	
Phasing sine/cosine	90° ±1°; < ±3° (20 kHz)	
Phasing reference signal	sin 45°, cos 135°	
Signal period	1000 µm	

Signal forms

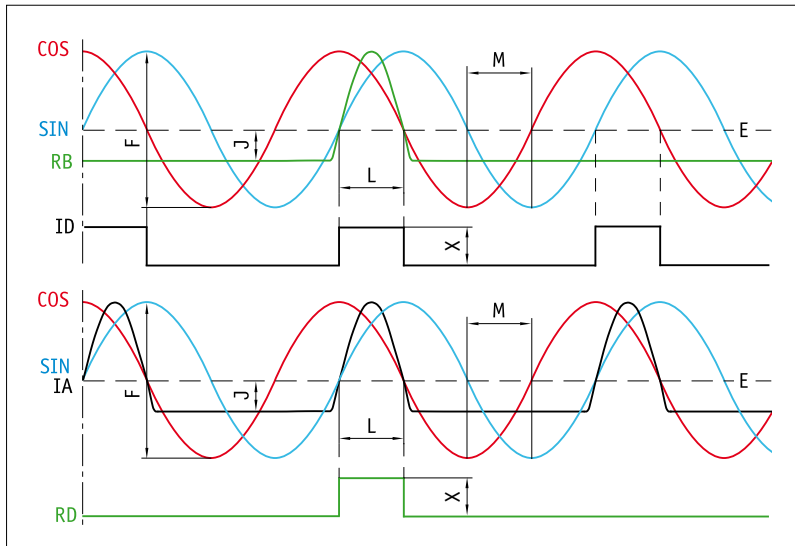

E: reference voltage 2.5 V
 F: 1 V_{SS} ±10 %
 J: ≥0.2 V
 L: 100° ±20°
 M: 90° ±1.0° / < ±3° (25 kHz)
 X: 1 V_{SS}

5.1

Pin assignment

without reference signal

signal	E1	E6X
GND	black	1
sin	red	2
/sin	orange	3
cos	yellow	4
/cos	green	5
+UB	brown	6
N.C.		7

with reference signal

signal	E1	E6X
sin	red	1
cos	yellow	2
index	blue	3
+UB	brown	4
GND	black	5
/sin	orange	6
/cos	green	7
/index	violet	8

Mounting instruction

On systems with reference points on the magnetic band, please ensure the correct alignment of the sensor and band (see diagram).

Reference signal	O, I, ID	RB, RD
Sensor/band reading distance A	max. 0.4 mm	max. 0.2 mm
Lateral offset B	max. ±2 mm	max. ±0.5 mm

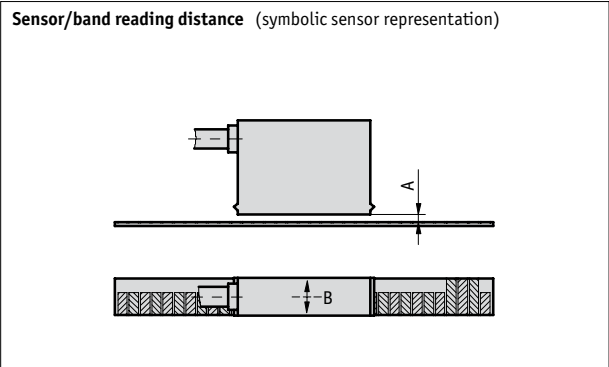

Order

Order table

Feature	Order data	Specifications	Additional information
Operating voltage	10	10.5 ... 30 V DC	
	5	5 V DC ±5 %	
Type of connection	E1		
	E6X		cable extensions on request
Cable length L	...	1 ... 20 m, in steps of 1 m	
Reference signal	O	without	
	IA	index periodic (analog)	index signal every 1 mm
	ID	index periodic (digital)	index signal every 1 mm
	RB	fixed, band side (analog)	
	RD	fixed, band side (digital)	

Order code

LE100/1 - - - - -

A B C D S

Scope of delivery: LE100/1, User information, Allen fastening screws M3 x 14 mm ISO 4762, lock washers M3 DIN 7980, strain relief for sensor cable, distance gage 0.2 mm

Additional information:

Short Description, Technical Details
Product Overview

Page 14 cont.
Page 4 cont.

Profile

- Repeat accuracy max. $\pm 1 \mu\text{m}$
- Output circuit sin/cos 1 V_{SS}
- Signal period 1000 μm (analog)
- Real-time signal processing

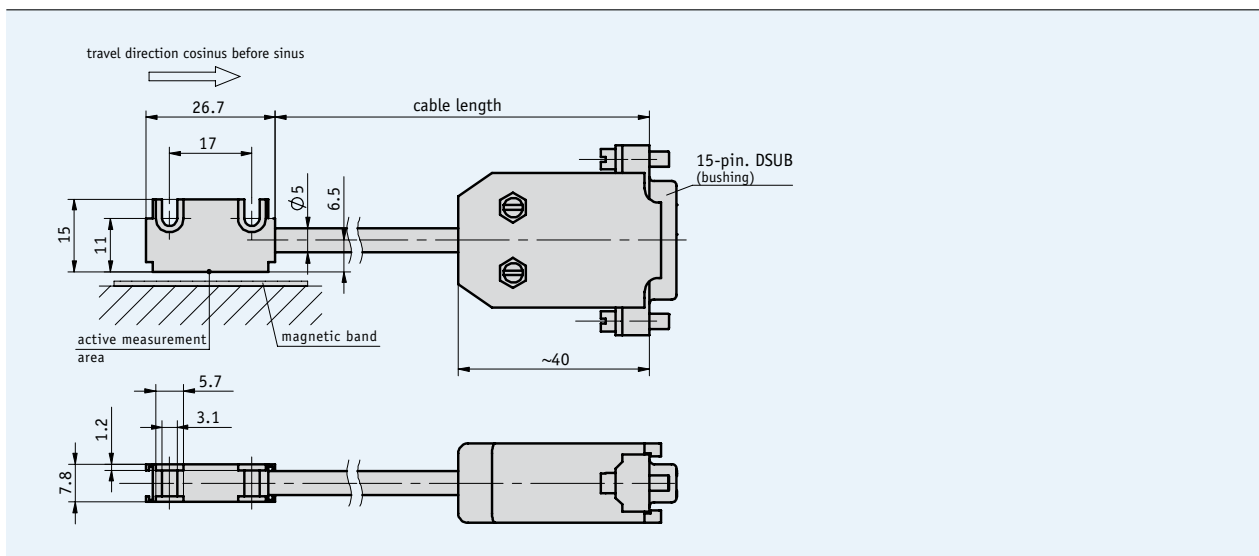
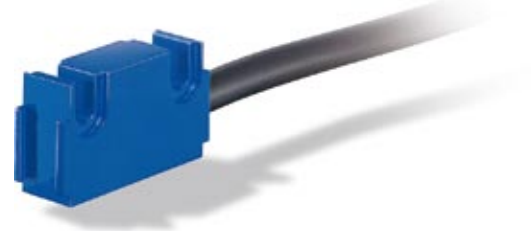

5.1

Mechanical data

Feature	Technical data	Additional information
Scale embodiment	MB100	
System accuracy	$\pm 10 \mu\text{m}$	accuracy class 10 μm only with MB100
Repeat accuracy	max. $\pm 1 \mu\text{m}$	unidirectional
Sensor/band reading distance	0.1 ... 0.4 mm reference signal RB <0.2 mm	over total measuring length, without cover strip
Travel speed	max. 20 m/s	
Housing	zinc die-cast	
Sensor cable	PUR	drag chain-compatible
Operating temperature	-10 ... +70°C	
Storage temperature	-30 ... +80°C	
Humidity	100 % rh	condensation permitted
Protection category	IP67	
Vibration resistance	<200 m/s ² (50 ... 2000 Hz)	
Max. measuring length	infinite	

Electrical data

Feature	Technical data	Additional information
Operating voltage	24 V DC ±20 % 5 V DC ±5 %	reverse-polarity protection on UB no reverse-polarity protection on UB
Current consumption	approx. 30 mA	no load
Type of connection	D-SUB-connector 15 pins	
Output circuit	1 V _{SS}	
Output signals	sin, cos, /sin, /cos	
Interference protection class	3	according to IEC 801
Real-time requirement	real-time signal processing	
Signal amplitude	1 V _{SS} ±10 %	with RA = 120 Ohm up to 1 kOhm at 0 ... 20 °C
Output impedance	R _{load} >75 Ohm	
Offset sine/cosine	2.5 V ±0.5 %	
Phasing sine/cosine	90° ±1°; < ±3° (20 kHz)	
Signal period	1000 μm	

Signal forms

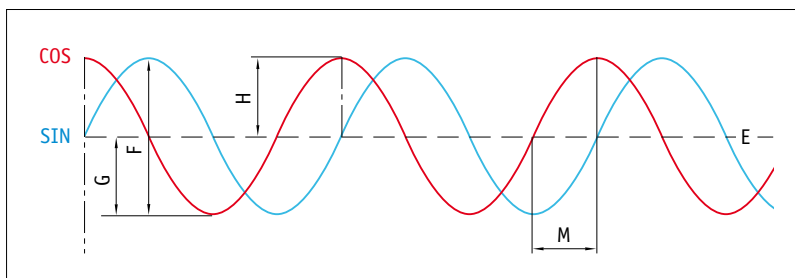

E: 0 V ±5 mV (reference voltage 2.5 V)
 F: 1 V_{SS} ±10 %
 Ratio of G and H: offset ±10 mV
 M: 90° ±1.5° / < ±3° (20 kHz)

Pin assignment

Signal	PIN
GND (0V)	2, 10, 14
/B (cos-)	5
B (cos+)	6
A (sin+)	7
/A (sin-)	8
+UB	12
N.C.	1, 3, 4, 9, 11, 13, 15

Mounting instruction

Sensor/band reading distance A	max. 0.4 mm
Lateral offset B	max. ±2 mm

 *The length of the cable between the sensor and connector cannot be subsequently increased or decreased.*

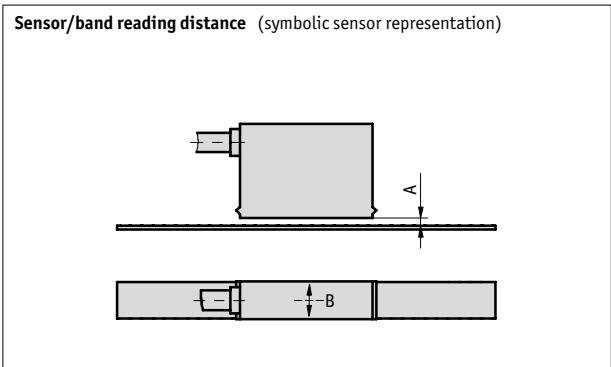

Order

Order table

Feature	Order data	Specifications	Additional information
Operating voltage	4	24 V DC ±20 %	
	5	5 V DC ±5 %	
Cable sheath	PVC	oil-resistant	
	PUR		
Cable length L	...	1 ... 20 m, in steps of 1 m	

Order code

LS100 - - -
A B C

Scope of delivery: LS100, User information, Allen fastening screws M3 x 14 mm ISO 4762, lock washers M3 DIN 7980, strain relief for sensor cable, distance gage 0.2 mm

Additional information:

Short Description, Technical Details
Product Overview

Page 14 cont.
Page 4 cont.

Profile

- Max. resolution of 1 μm in combination with MA100/2
- Repeat accuracy max. $\pm 1 \mu\text{m}$ in combination with MA100/2
- Small, compact design

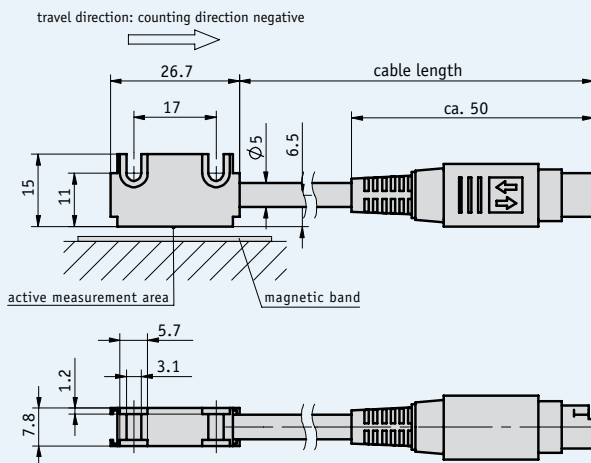

Mechanical data

Feature	Technical data	Additional information
Scale embodiment	MB100	
System accuracy	$\pm(0.01+0.01 \times L)$ mm, L in m	in combination with MA100/2
Repeat accuracy	max. 1 μm	in combination with MA100/2
Sensor/band reading distance	max. 0.4 mm	over total measuring length
Travel speed	max. 5 m/s	
Housing	varnished aluminum, blue	
Sensor cable	PVC or PUR oil-resistant	
Operating temperature	-20 ... +70 °C	
Storage temperature	-20 ... +85 °C	
Humidity	100 % rh	condensation permitted
Protection category	IP67	
Vibration resistance	10 g/50Hz	

Electrical data

Feature	Technical data	Additional information
Operating voltage	feed via magnetic display	
Current consumption	feed via magnetic display	
Type of connection	DIN mini-connector	for magnetic display MA100/2
Real-time requirement	real-time signal processing	

Mounting instruction

Sensor/band reading distance A	max. 0.4 mm
Lateral offset B	max. ±2 mm

Sensor/band reading distance (symbolic sensor representation)

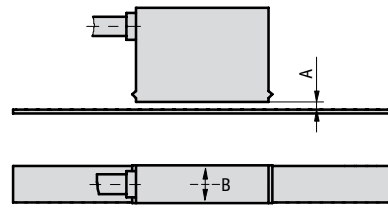

5.1

Order

Order table

Feature	Order data	Specifications	Additional information
Cable sheath	PVC	oil-resistant	
	PUR		
Cable length L	...	B	1 ... 10 m, in steps of 1 m

Order code

MS100/1 - - -

Scope of delivery: MS100/1, User information, Allen fastening screws M3 x 14 mm ISO 4762, lock washers M3 DIN 7980, strain relief for sensor cable, distance gage 0.2 mm

Additional information:

Short Description, Technical Details
Product Overview

Page 14 cont.
Page 4 cont.

Profile

- Max. display accuracy 1 µm
- Repeat accuracy ±1 digit, max. ±1 µm
- High-contrast LCD, 12-digit LCD dot matrix
- Incremental measurement and reference circuit
- Option: serial interface RS232/RS485



5.1

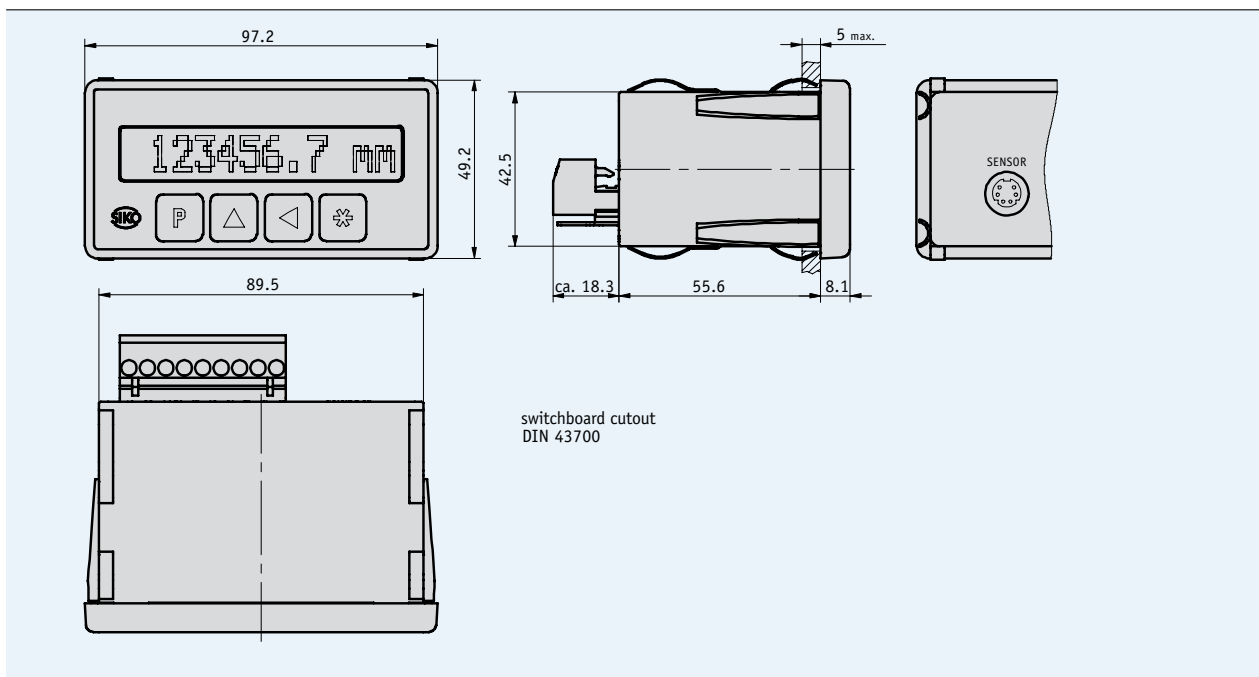

Mechanical data

Feature	Technical data	Additional information
System accuracy	±(0.01 + 0.01 × L) mm, L in m	at T _U = 20 °C with MB100
Repeat accuracy	±1 digit	
Magnetic sensor	type MS100/1	incremental
Supply connection	9-pin screw-type terminal strip (EG)	IEC connector TG
Sensor connection	Mini-DIN-bush	pluggable
Calibration input	9-pin screw-type terminal strip	
Display/display range	12-digit LCD dot matrix	-9 999 999 ... +9 999 999 sign + units
Housing	plastic black	
Protection category	IP 40 acc. to DIN40050 for whole device	IP60 according to DIN 40050 with switchboard installation
Operating temperature	0 ... +50 °C	
Storage temperature	-20 ... +80 °C	
Humidity	95 % rh	condensation inadmissible

Electrical data

Feature	Technical data	Additional information
Operating voltage	24 V DC ±20 % 230 V AC ±10 % 115 V AC ±10 %	
Current consumption	70 mA 20 mA 10 mA	24 V, incl. sensor 115 V, inkl. Sensor 230 V, incl. sensor
Interfaces/protocol	without RS232 with standard protocol RS485 with standard protocol	
Resolution	0.001, 0.01, 0.1, 1, 10 0.001, 0.01, 0.1, 1	in mm in inch
Interference protection class	3 according to IEC 801	
Switching output	with or without	

Pin assignment

Signal	Terminal
RESET	1
UB = +24 V DC (for reference switch) max. 50mA	2
GND	3
	4
RS232 (RXD) RS485 (DÜB) A2	5
RS232 (TXD) RS485 (DÜA) A1	6
PE	7
N (230/115 V AC) GND (24 V DC)	8
L (230/115 V AC) UB (24 V DC)	9

5.1

Order

Order table

Feature	Order data	Specifications	Additional information
Operating voltage	1	230 V AC ±10 %	
	2	115 V AC ±10 %	
	4	24 V DC ±20 %	
Interface/protocol	XX/XX	without	
	S1/00	RS232 with standard protocol	
	S3/00	RS485 with standard protocol	
Switching output	S0	without	
	SM	with	only with interface XX/XX

Order code

MA100/2 - **EG** - **A** - **RM** - **B** - **C**

Scope of delivery: MA100/2, User information

Additional information:

Short Description, Technical Details
Product Overview

Page 14 cont.
Page 4 cont.

Magnetic Band MBA111

Absolutely coded scale, 4000 mm measuring length

Profile

- Absolutely coded scale MBA111 with 10 mm width
- Easy mounting, self-assembly possible

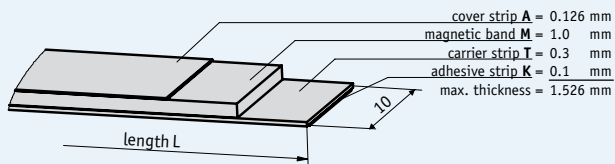

Mechanical data

Feature	Technical data	Additional information
Measuring length	max. 4000 mm	
Band width	10 mm	
Thickness	1.4 mm	without cover strip
Temperature coefficient	$(11 \pm 1) \times 10^{-6} / \text{K}$	
Operating temperature	-20 ... +70 °C	
Storage temperature	-30 ... +80 °C	
Humidity	100 % rh	condensation permitted
Mounting type	glued joint	pre-assembled double-sided adhesive strip
Cover strip material	stainless steel	

Order

The necessary band length is calculated as follows:
 Measured path + sensor length "S" + (2 x lead-in and lead-out "B"). Sensor length "S" refer to the drawing of the employed sensor, lead-in and lead-out "B" = 5 mm.

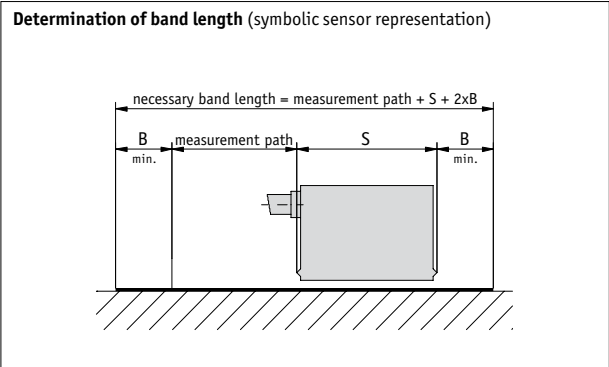

■ **Order table**

Feature	Order data	Specifications	Additional information
Length of magnetic band	... A	0.2 ... 4.09 m, in steps of 0.01-m	Order information, see "Determination of band length"
Adhesive carrier strip	TM B	with	
	TO	without	
Cover strip	AM C	with	
	AO	without	

5.1

■ **Order code**

MBA111 - - -
 A B C

Scope of delivery: MBA111, User information



Additional information:

Short Description, Technical Details
 Product Overview

Page 14 cont.
 Page 4 cont.

Profile

- Max. resolution of 1 µm in combination with AEA111/1
- Repeat accuracy ±1 µm in combination with AEA111/1
- Additionally 1 V_{SS} for highly dynamic controls



5.1

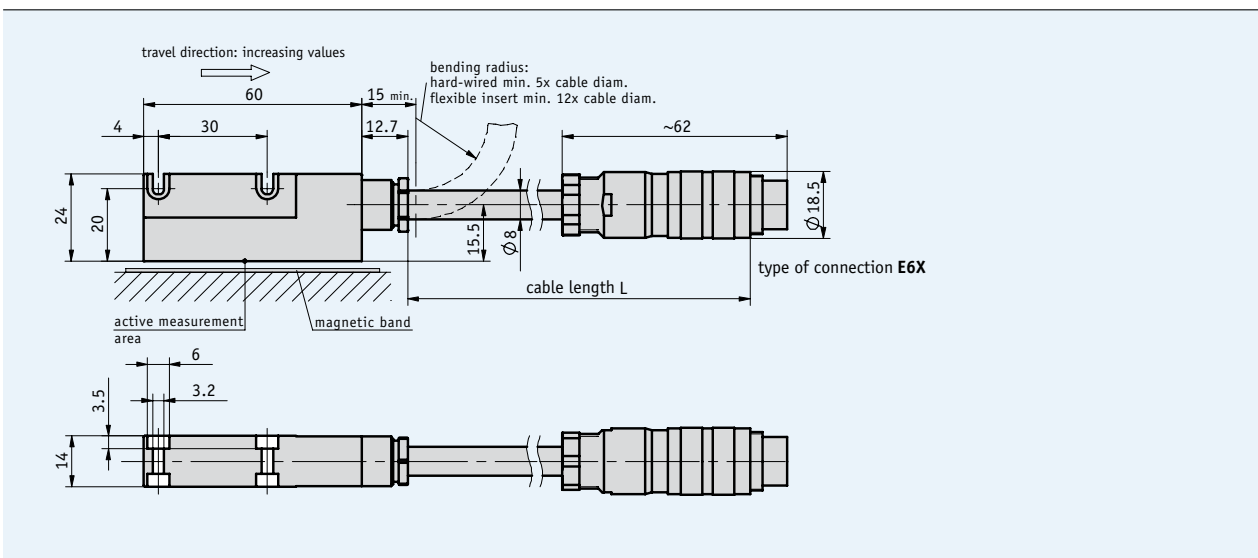

Mechanical data

Feature	Technical data	Additional information
Scale embodiment	MBA111	
System accuracy	±10 µm	
Repeat accuracy	max. ±1 µm	
Sensor/band reading distance	max. 0.1 mm max. 0.2 mm	(with cover strip on magnetic band) (without cover strip on magnetic band)
Travel speed	<0.3 m/s (SSI) <10 m/s (sin/cos)	static operation dynamic operation
Housing	aluminum	
Sensor cable	PUR	max. 20 m
Operating temperature	-10 ... +60 °C	
Storage temperature	-30 ... +80 °C	
Humidity	100 % rh	condensation permitted
Protection category	IP67	
Vibration resistance	10 g/50 Hz	
Max. measuring length	max. 4000 mm	

Electrical data

Feature	Technical data	Additional information
Operating voltage	fed by AEA111/1	
Current consumption	see AEA111/1	
Type of connection	round connector	
Output circuit	see AEA111/1	
Resolution	see AEA111/1	
Interference protection class	3	IEC-61000-6-2
Real-time requirement	real-time signal processing via AEA111/1	sin/cos output
Signal amplitude	1 V _{SS}	

Pin assignment

Signal	PIN
+UB	A
A_Abs	B
B_Abs	C
C_Abs	D
CS_0_Abs	E
CS_1_Abs	F
CS_2_Abs	G
Data_Abs_Digi	H
Data_Abs_Ana	I
GND	K
Sense+	L
Sense-	M
AVCC LK	N
sin+ LK	O
sin- LK	P
cos+ LK	R
cos- LK	S
AGND	T
Screen internal layers	U

5.1

Mounting instruction

When installing the sensor and magnetic band, always ensure that both system components are correctly aligned. The arrows marked on the band and sensor must point in the same direction during installation.

Cover strip auf MB	without	with
Reading distance A	max. 0.2 mm	max. 0.1 mm
Lateral offset B	max. ±0.3 mm	max. ±0.3 mm

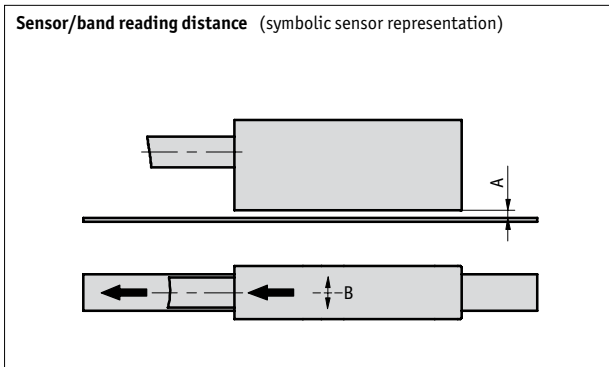

Order

Order note

This sensor is sold in Switzerland and Austria under the product name "AMSA111".

Order table

Feature	Order data	Specifications	Additional information
Cable length L	...	A 1 ... 20 m, in steps of 1 m	

Order code

MSA111 - E6X -

5.1

Scope of delivery: MSA111, User information, strain relief for sensor cable, distance gage

Accessories:

Cable extension KV18S0
Cable extension KV18S1

Page 175
Page 176

Additional information:

Short Description, Technical Details
Product Overview

Page 14 cont.
Page 4 cont.

Profile

- Max. resolution 1 µm
- Repeat accuracy ±1 µm
- Snap module, easy mounting on standard rail
- Parameters adjustable via DIP switches
- SSI and RS485 interfaces
- Connection to Inter-bus, CAN bus, Profibus bus systems possible via SIKO-IF09x interface module

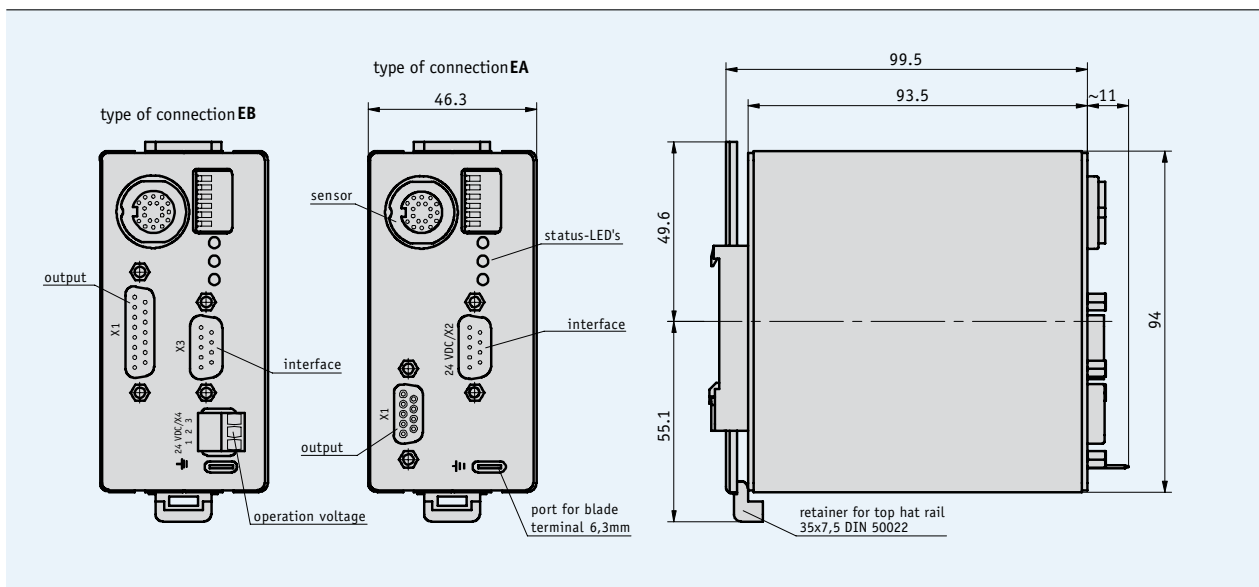

5.1

Mechanical data

Feature	Technical data	Additional information
System accuracy	±10 µm	
Repeat accuracy	max. ±1 µm	
Travel speed	<0.3 m/s SSI <10 m/s (sin/cos)	static operation with MSA111 dynamic operation with MSA111
Housing	aluminum	
Electrical connection	round connector for sensor connection D-SUB for signal output and supply or screw-type terminal for supply	19-pin EA type of connection EB type of connection (separate voltage supply)
Protection category	IP20	
Humidity of translation module	inadmissible	
Operating temperature	0 ... +60 °C	
Storage temperature	-30 ... +80 °C	
Vibration resistance	10 g/50 Hz	
Max. measuring length	4000 mm	in combination with magnetic sensor MSA111

Electrical data

Feature	Technical data	Additional information
Operating voltage	24 V DC ±20 %	
Current consumption	<250 mA with 24 V DC	
Resolution	max. 1µm	
Interfaces	SSI RS485	data available max. 100 ms after applying operating voltage
Output circuit	1 V _{SS}	
Output signals	sin, cos, absolute, SSI	
Real-time requirement	real-time signal processing sin/cos output	
Cycle time absolute value indication	<2 ms	
Interference protection class	3	unwanted emission according to DIN EN 61000-6-4 interference immunity according to DIN EN 61000-6-2

Pin assignment

EA type of connection X1 output

Signal	PIN
sin+	1
sin-	2
cos+	3
cos-	4
analog GND	5
N.C.	6-9

EA type of connection X2 interface

signal	PIN
+24 V DC	1
SSI clock +	2
RS485 DÜA	3
Config in	4
GND	5
SSI data +	6
SSI clock -	7
RS485 DÜB	8
SSI data -	9

EB type of connection X1 interface

Signal	PIN
GND	1
Ext_Config	2
sin-	3
cos-	4
analog_GND	5
SSI clock -	6
SSI clock +	7
sin+	8
cos+	9
Digital_GND	10
Digital_GND	11
analog_GND	12
analog_GND	13
SSI_data-	14
SSI_data+	15

EB type of connection X3 Interface

signal	PIN
N.C.	1
SSI clock +	2
RS485 DÜA	3
Ext_Config	4
GND	5
SSI data+	6
SSI clock-	7
RS485 DÜB	8
SSI data-	9

EB type of connection X4 operating voltage

signal	PIN
+24 V DC	1
GND	2
Ext_Config	3

5.1

Order

Order table

Feature	Order data	Specifications	Additional information
Type of connection	EA	integrated supply	via D-Sub/signal line
	EB	separate power supply	via 3-pin screw-type terminal strip

Order code

ASA111/1 - SSI - 1 V_{SS} - S - A

Scope of delivery: AEA111/1, User information

Accessories:

Cable extension KV18S0
 Cable extension KV18S1

Page 175
 Page 176

Additional information:

Short Description, Technical Details
 Product Overview

Page 14 cont.
 Page 4 cont.

mm 5.2

MSK5000

2 mm

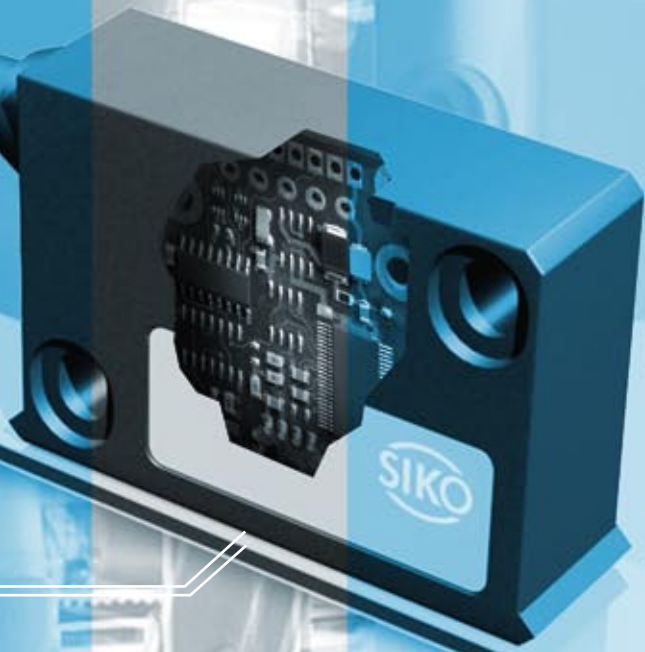

5.0 MagLine Product Overview	3
5.1 MagLine Micro	12

5.2 | MagLine Basic

Short Description, Technical Details		46
Product Matrix		47
Products		
incremental	MB200	50
	MB320	52
	MB500	54
	MSK210	56
	MSK320	59
	MSK5000	62
	MS500	66
	MA502	68
	MA506	70
	AS510/1	72
absolute	MBA	74
	MBA511	76
	MSA	78
	MSA510/1	80
	MSA511	82
	MA505	84
	MA561	86
	AEA	88
quasi-absolute	MA501	90
	MA503/1	93
	MA503WL	96
	RTX500	99
	MA504	101
	MA508	104
	MA564	106
	ASA510	108

5.3 MagLine Macro	110
5.4 MagLine Roto	134
5.5 Accessories	168
5.6 Appendix	182
5.7 Product index, Contact information	188

5.0

5.1

5.2

5.3

5.4

5.5

5.6

5.7

Introduction

The track-proven and mature Basic range features a varied number of components for incremental and absolute measurement through to the μm range. All measured values can be displayed directly and also processed further by controllers. MagLine Basic is equipped with interfaces for integration into almost all industrial environments.

- Resolutions max. 1 μm
- Repeat accuracy max. 10 μm
- Absolute accuracy up to 20 μm

Product matrix³ – the key to variety

In accordance with its three functional groups and for a faster overview, the MagLine Basic components and their possible combinations are shown in the following product matrices:

1. Incremental systems and

2. Absolute systems

as configurable individual components with a choice between signal evaluation via digital output, a translation module or indicators

3. Absolute systems with hard-wired sensor

For direct indication or evaluation of the measured signal

While free and flexible integration and the related combinability of individual components are the main feature of the incremental and absolute systems (matrices 1 and 2), ready-for-use absolute systems with their integrated sensors (matrix 3) have the “plug and play” advantage. These closed circuit systems are extremely suitable for the direct use of signals at the measuring point (display, evaluation).



Magnetic bands

Available length up to 90 m
Accuracy class up to 20 μm
Reference points as an option

Sensors

Direct connection to translation module and magnetic displays
Max. tolerance of reading distance to scale 2 mm

Translation module

Incremental and absolute position tracking
Real-time signal processing
Resolution 1 μm

Magnetic displays

Incremental and absolute position tracking
Resolution and repeat accuracy up to 10 μm





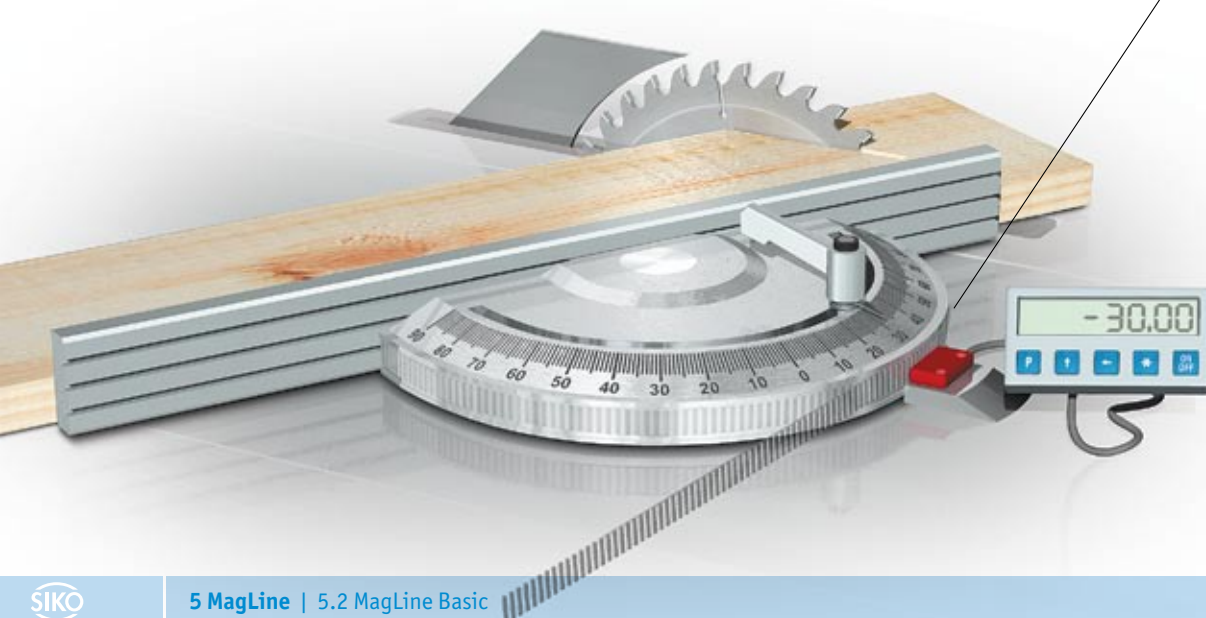



The magnetic band serves as a scale in the measuring system. Its flexible design also permits curved installation on small radii for easy angle measurement.





MagLine Basic

Signal analysis via	Incremental systems					
	Output, digital		Translation module	Magnetic display		
System accuracy class (μm)	± 50	± 100	± 25	± 25	± 100	± 50
Maximum repeat accuracy (μm)	± 25	± 40	± 10	± 5	± 10	± 10
Maximum measurement length/magnetic display (mm)	infinite	infinite	infinite	infinite	± 99.999	$\pm 9.999.999$
Maximum reading distance (mm)	1.0	2.0	2.0	2.0	2.0	2.0

Resolution max. in μm	Supply voltage	Output/ interface	Magnetic sensor	Page			
25	24 V DC 5 V DC	PP, LD, TTL	MSK210	56			
40	24 V DC 5 V DC	PP, LD, TTL	MSK320	59			
1	6.5 ... 30 V DC 4.75 ... 6 V DC	LD	MSK5000	62			
*)	feed via downstr. electronics unit	—	MS500	66			

					Magnetic display		
10	24 V DC 230 V AC 115 V AC	RS232	MA502	68			
10	24 V DC 230 V AC	—	MA506	70			





















					Translation module		
5	24 V DC 5 V DC	PP, LD	AS510/1	72			









Width in mm	Accuracy class in μm	Available length max. in m/ piece	Magnetic band	Page			
10	0.05	90.0	MB200	50			
5 or 10	0.1	90.0	MB320	52			
5 or 10	0.1 or 0.05	90.0	MB500	54			

*) depending on the downstream electronics or magnetic display

MagLine Basic

Signal analysis via	Absolute systems				
	Magnetic display	Translation module	Interface		
System accuracy class (μm)	± 50	± 50	± 50	± 50	± 100
Maximum repeat accuracy (μm)	± 10	± 10	± 10	± 10	± 10
Maximum measurement length/magnetic display (mm)	5120	5120	5120	5120	20480
Maximum reading distance (mm)	1.0	1.0	1.0	1.0	2.0

Resolution max. in μm	Supply voltage	Output/ interface	Magnetic sensor	Page							
*)	**)	—	MSA	78							
10	10 ... 30 V DC	SSI or RS485	MSA510/1	80							
10	24 V DC	SSI	MSA511	82							

					Magnetic display								
10	24 V DC 230 V AC 115 V AC	RS232	MA505	84									
10	10 ... 30 V DC	—	MA561	86									

					Translation module								
10	24 V DC	PP, SSI, Profibus, RS232, RS485	AEA	88									









Width in mm	Accuracy class in μm	Available length max. in m/ piece	Magnetic band	Page									
20	± 50	75.0	MBA	74									
20	± 100	90.0	MBA511	76									

*) depending on the downstream electronics or magnetic display, **) feed via downstream electronics unit

MagLine Basic

Absolute systems with hard-wired sensor

Signal analysis via	Magnetic display						Translation module
System accuracy class (μm)	± 100	± 100	± 100	± 100	± 100	± 100	± 25
Maximum repeat accuracy (μm)	± 10	± 10	± 10	± 10	± 100	± 10	± 10
Maximum measurement length/magnetic display (mm)	$\pm 999\,999$	$\pm 999\,999$	$\pm 999\,999$	$\pm 999\,999$	$\pm 999\,999$	$\pm 999\,999$	$\pm 655\,000$
Maximum reading distance (mm)	2.0	2.0	2.0	2.0	2.0	2.0	2.0

Resolution max. in μm	Supply voltage	Output/ interface	Magnetic display	Page						
10	24 V DC 1.5 V DC backup	RS485	MA501	90						
10	3 V DC 1.5 V DC	—	MA503/1	93						
10	3 V DC	—	MA503WL sender	96						
	24 V DC	RS232, RS485	RTX500 receiver	99						
10	1 ... 3.3 V DC	—	MA504	101						
100	internal 3 V DC	—	MA508	104						
10	10 ... 30 V DC 3 V DC backup	—	MA564	106						
			Translation module							
10	24 V DC	SSI, RS485	ASA510	108						

Width in mm	Accuracy class in μm	Available length max. in m/ piece	Magnetic band	Page							
5 or 10	0.1 or 0.05	90.0	MB500	54							

Subject to technical alterations 10/2008

Magnetic Band MB200

Incrementally coded scale, 2 mm pole length

Profile

- Easy adhesive mounting, self-assembly possible
- Pole length 2 mm
- System accuracy up to 20 µm

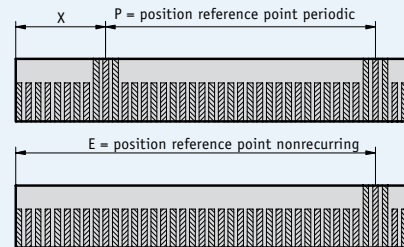
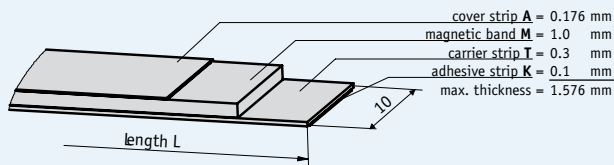

Reference points (all details in mm)

X	0.05
P	0.2, 0.5
E	0.05, 0.1, 0.2, 0.5

Mechanical data

Feature	Technical data	Additional information
Pole length	2 mm	
Measuring length	infinite	
Band width	10 mm	
Thickness	1.4 mm	without cover strip
Accuracy class	50 µm	
Temperature coefficient	$(11 \pm 1) \times 10^{-6}/K$	spring steel
Operating temperature	-20 ... +70 °C	
Storage temperature	-40 ... +70 °C	
Humidity	100 % rh	condensation permitted
Mounting type	glued joint	pre-assembled double-sided adhesive strip
Cover strip material	stainless steel	

Order

The necessary band length is calculated as follows:
Measured path + sensor length "S" + (2 x lead-in and lead-out "B"). Sensor length "S" refer to the drawing of the employed sensor, lead-in and lead-out "B" = 10 mm.

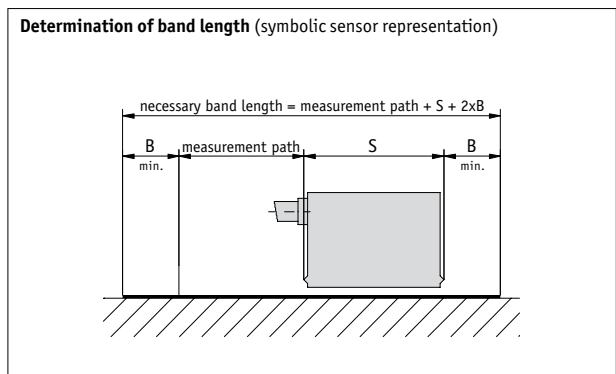

■ **Order table**

Feature	Order data	Specifications	Additional information
Length of magnetic band	... A	0.1 ... 90 m, in steps of 0.1 m	Order information, see "Determination of band length"
Adhesive carrier strip	TM B	with	
	TO B	without	
Cover strip	AM C	with	stainless steel
	AO C	without	
Reference point	O D	without	
	E D	one-time	
	P D	periodic	
Position of reference point E one-time	... E	0.05, 0.1, 0.2, 0.5 others on request	indicate only if reference point E was selected
or Position of reference point P periodic	... E	0.2, 0.5 others on request	indicate only if reference point P was selected

■ **Order code**



Scope of delivery: MB200, User information

Accessories:

- Profile rail PS Page 178
- Protective strip SB Page 179
- Cover rail PS1 Page 177

Additional information:

- Short Description, Technical Details Page 46 cont.
- Product Overview Page 4 cont.

Magnetic Band MB320

Incrementally coded scale, pole length 3.2 mm

Profile

- Easy adhesive mounting, self-assembly possible
- Pole length 3.2 mm
- System accuracy up to 100 µm

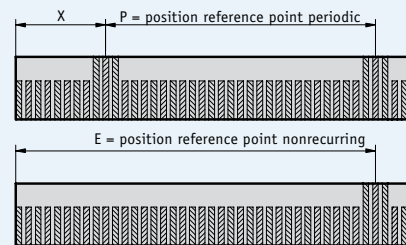
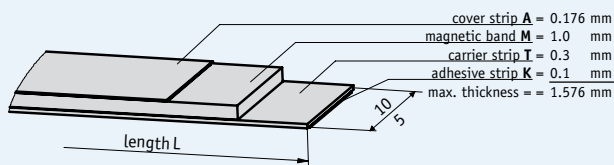

Reference points (all details in mm)

X	0.032
P	0.32, 0.64
E	0.032, 0.064, 0.128, 0.32

Mechanical data

Feature	Technical data	Additional information
Pole length	3.2 mm	
Measuring length	infinite	
Band width	10 mm	
	5 mm	
Thickness	1.4 mm	without cover strip
Accuracy class	100 µm	
Temperature coefficient	$(11 \pm 1) \times 10^{-6}/K$ $(16 \pm 1) \times 10^{-6}/K$	spring steel stainless steel
Operating temperature	-20 ... +70 °C	
Storage temperature	-40 ... +70 °C	
Humidity	100 % rh	condensation permitted
Mounting type	glued joint	pre-assembled double-sided adhesive strip
Cover strip material	stainless steel	

Order

The necessary band length is calculated as follows:
Measured path + sensor length "S" + (2 x lead-in and lead-out "B"). Sensor length "S" refer to the drawing of the employed sensor, lead-in and lead-out "B" = 10 mm.

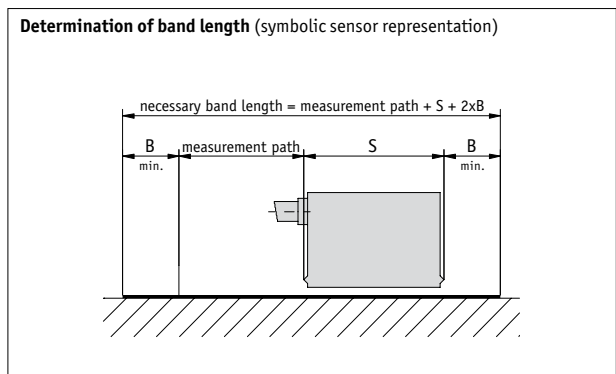

■ **Order table**

Feature	Order data	Specifications	Additional information
Width	10	in mm	
	5	in mm	
Length of magnetic band	...	0.1 ... 90 m, in steps of 0.1 m	Order information, see "Determination of band length"
Carrier strip	St	steel	
	VA	stainless steel	
Length of carrier strip	...	0.1 ... 90 m, in steps of 0.1 m	Order information, see "Determination of band length"
Adhesive carrier strip	TM	with	
	TO	without	
Cover strip	AM	with	stainless steel
	AO	without	
Reference point	O	without	
	E	one-time	only with width 10 mm
	P	periodic	only with width 10 mm
Position of reference point E one-time or	...	0.032, 0.064, 0.128, 0.320	indicate only if reference point E was selected
	...	others on request	
Position of reference point P periodic	...	0.32, 0.64	indicate only if reference point P was selected
	...	others on request	

■ **Order code**



Scope of delivery: MB320, User information

Accessories:

- Profile rail PS Page 178
- Protective strip SB Page 179
- Cover rail PS1 Page 177

Additional information:

- Short Description, Technical Details Page 46 cont.
- Product Overview Page 4 cont.

Magnetic Band MB500

Incrementally coded scale, pole length 5 mm

Profile

- Easy adhesive mounting, self-assembly possible
- Pole length 5 mm
- System accuracy up to 50 μm

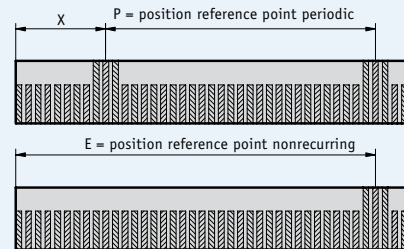
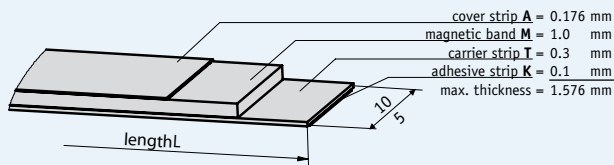

Reference points (all details in mm)

X	0.05
P	0.2, 0.5
E	0.05, 0.1, 0.2, 0.5, 0.9, 1.3, 2.0

Mechanical data

Feature	Technical data	Additional information
Pole length	5 mm	
Measuring length	infinite	
Band width	10 mm	
	5 mm	
Thickness	1.4 mm	without cover strip
Accuracy class	50 μm or 100 μm	
Temperature coefficient	$(11 \pm 1) \times 10^{-6}/\text{K}$ $(16 \pm 1) \times 10^{-6}/\text{K}$	spring steel stainless steel
Operating temperature	-20 ... +70 °C	
Storage temperature	-40 ... +70 °C	
Humidity	100 % rh	condensation permitted
Mounting type	glued joint	pre-assembled double-sided adhesive strip
Cover strip material	stainless steel	

Order

The necessary band length is calculated as follows:
Measured path + sensor length "S" + (2 x lead-in and lead-out "B"). Sensor length "S" refer to the drawing of the employed sensor, lead-in and lead-out "B" = 10 mm.

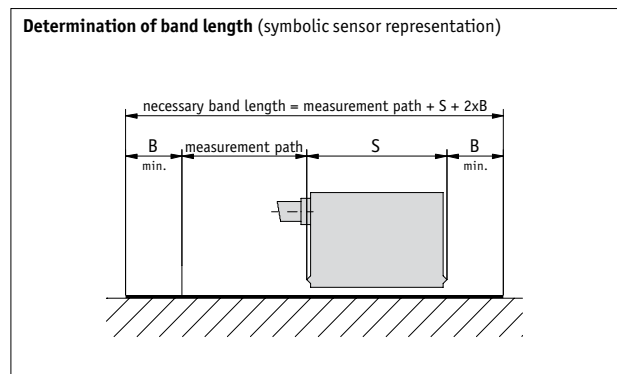

Order table

Feature	Order data	Specifications	Additional information
Width	10	A in mm	
	5	A in mm	
Accuracy class*	0.1	B 0.1 mm	
	0.05	B 0.05 mm	only with width 10 mm
Carrier strip	St	C steel	
	VA	C stainless steel	only with width 10 mm
Length	...	D 0.1 ... 90 m, in steps of 0.1 m	Order information, see "Determination of band length"
Adhesive carrier strip	TM	E with	
	TO	E without	
Cover strip	AM	F with	stainless steel
	AO	F without	
Width of cover strip	10	G in mm	
	5	G in mm	
Reference point	O	H without	
	E	H one-time	only with width 10 mm
	P	H periodic	only with width 10 mm
Position of reference point E one-time	...	I 0.05, 0.1, 0.2, 0.5, 0.9, 1.3, 2.0	indicate only if reference point E was selected
		I others on request	
Position of reference point P periodic	...	I 0.2, 0.5	indicate only if reference point P was selected
		I others on request	

Order code

MB500 - - - - - - - - - -

A B C D E F G H I

Scope of delivery: MB500, User information

Accessories:

Profile rail PS Page 178
Protective strip SB Page 179
Cover rail PS1 Page 177

Additional information:

Short Description, Technical Details Page 46 cont.
Product Overview Page 4 cont.

Magnetic Sensor MSK210

Incremental, digital interface, resolution 25 μm

Profile

- Max. resolution 25 μm
- Repeat accuracy ± 1 increment, max. ± 0.025 mm
- Works with magnetic band MB200
- Reading distance up to 1 mm

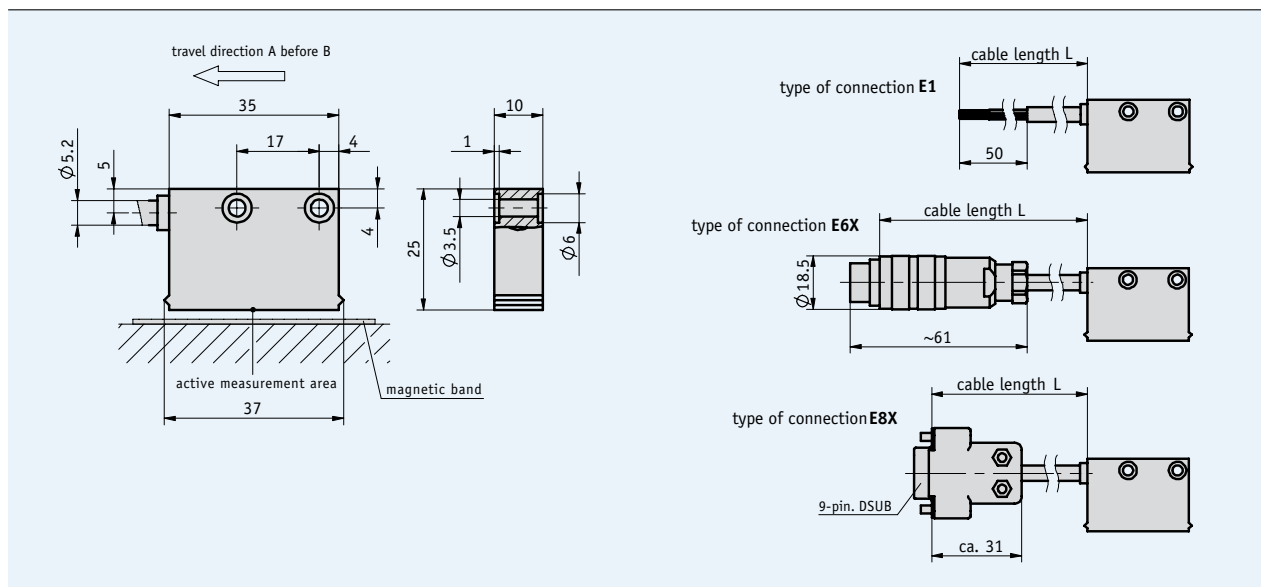

Mechanical data

Feature	Technical data	Additional information
Scale embodiment	MB200	
System accuracy	$\pm(0.05 + 0.01 \times L)$ mm, L in m	
Repeat accuracy	± 1 increment, max. ± 0.025 mm	
Sensor/band reading distance	0.1 ... 1 mm 0.1 ... 0.4 mm	with reference signals O, I with reference signal R
Travel speed	max. 25 m/s	max. referencing speed 2 m/s
Housing	plastic green	
Sensor cable	PUR	
Operating temperature	$-10 \dots +70$ °C	
Storage temperature	$-30 \dots +80$ °C	
Humidity	100 % rh	condensation permitted
Protection category	IP67	
Vibration resistance	10 g/50 Hz	
Max. measuring length	infinite	

Electrical data

Feature	Technical data	Additional information
Operating voltage	24 V DC ± 20 % 5 V DC ± 5 %	reverse-polarity protection on UB no reverse-polarity protection on UB
Current consumption	max. 70 mA	24 V no load
Type of connection	flying leads round connector D-SUB 9-pin	
Output circuit	PP, LD, TTL	PP only with 24 V
Output signals	A, B A, /A, B, /B, Option: I, /I, or R, /R	quadrature signal
Pulse width of reference signal	1 increment	
Resolution	0.025, 0.05, 0.1 mm	
Jitter	<15 % bei	sensor/band reading distance 0.5 mm
Interference protection class	3	according to IEC 801
Real-time requirement	real-time signal processing	
Signal level high	>UB – 2.5 V >2.5 V >2.4 V	with PP with LD with TTL
Signal level low	<0.8 V <0.5 V <0.4 V	with PP with LD with TTL

Signal forms

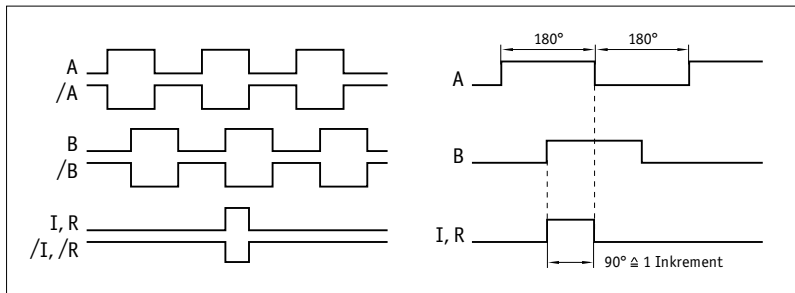

! The logical condition of signals A and B is not defined in reference to the index signal I or the reference signal R. It can deviate from the signal form.

5.2

Pin assignment

non-inverted

Signal	E1	E6X	E8X
A	red	3	3
B	orange	4	4
+UB	brown	2	2
GND	black	1	1
N.C.		5,6,7	5,6,7,8,9

inverted

Signal	E1	E6X	E8X
A	red	1	1
B	orange	2	2
+UB	brown	4	4
GND	black	5	5
A/	yellow	6	6
B/	green	7	7
N.C.		3	3, 8, 9

inverted with reference signal

Signal	E1	E6X	E8X
A	red	1	1
B	orange	2	2
I	blue	3	3
+UB	brown	4	4
GND	black	5	5
A/	yellow	6	6
B/	green	7	7
I/	violet	8	8
N.C.			9

Mounting instruction

On systems with reference points on the magnetic band, please ensure the correct alignment of the sensor and band (see diagram).

Reference signal	O, I	R
Sensor/band reading distance A	max. 0.8 mm	max. 0.4 mm
Lateral offset B	max. ±2 mm	max. ±0.5 mm

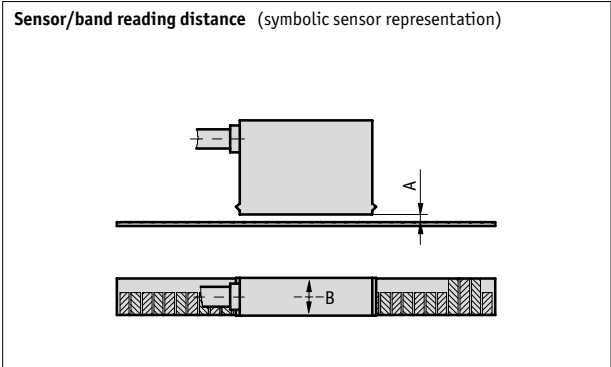

Order

Order table

Feature	Order data	Specifications	Additional information
Operating voltage	4	24 V DC ±20 %	reverse-polarity protection
	5	5 V DC ±5 %	
Type of connection	E1	flying leads, 2 m cable	
	E6X	round connector without mating connectors	
	E8X	D-SUB 9-pin without mating connectors cable extensions on request	
Cable length L	...	1 ... 20 m, in steps of 1 m	
Output circuit	PP	push-pull	only with operating voltage 4
	LD	line driver	
	TTL		only with non-inverted output signal, max. cable length 5 m
Output signal	NI	non-inverted	with reference signal I or R
	I	inverted	
Reference signal	O	without	not possible with resolution 0.5 mm
	I	index periodic	
	R	index fixed	
Resolution	...	0.025, 0.05, 0.1	

Order code

MSK210 - - - - - - - -

A B C D E F G

Scope of delivery: MSK210, User information, Allen fastening screws M3 x 14 mm ISO 4762, lock washers M3 DIN 7980, strain relief for sensor cable, distance gage 0.3 mm

Additional information:

Short Description, Technical Details
Product Overview

Page 46 cont.
Page 4 cont.

Profile

- Max. resolution 40 μm
- Repeat accuracy ±0.04 mm
- Works with magnetic band MB320
- Reading distance up to 2 mm

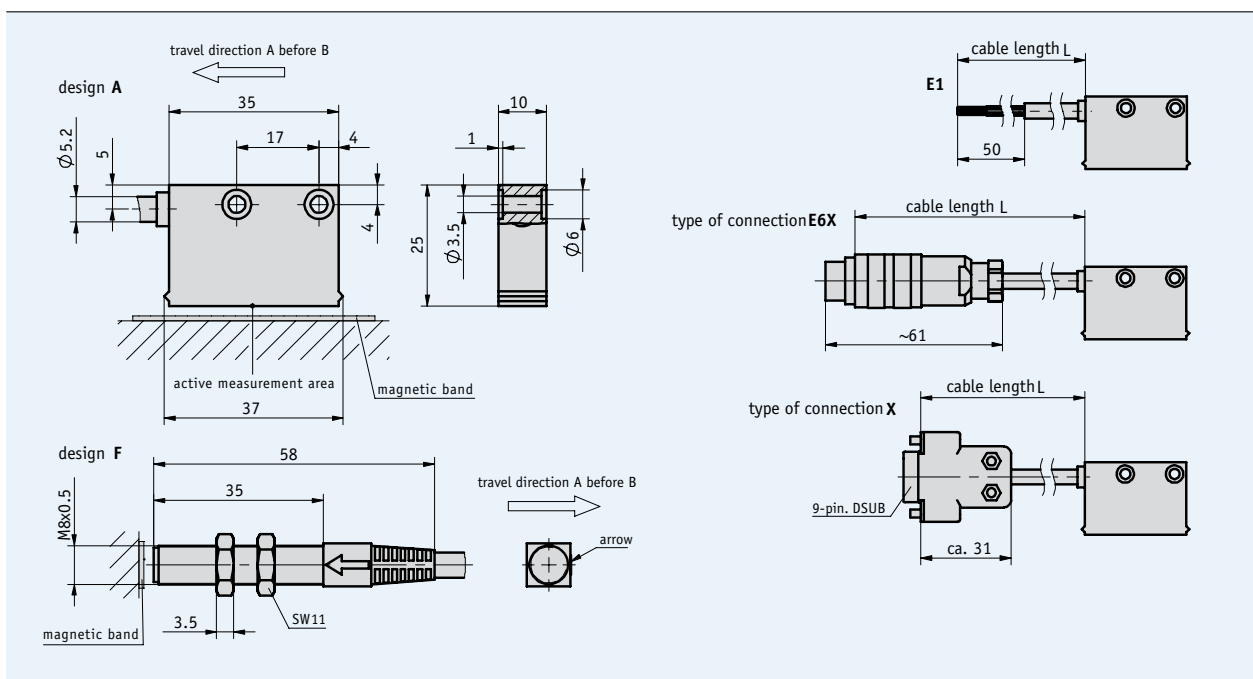

5.2

Mechanical data

Feature	Technical data	Additional information
Scale embodiment	MB320	
System accuracy	±(0.1 + 0.01 × L) mm, L in m	
Repeat accuracy	±1 increment	with T _U = 20 °C
Sensor/band reading distance	0.1 ... 2 mm 0.1 ... 1.5 mm	with reference signals 0, I with reference signal R
Travel speed	max. 25 m/s	max. referencing speed 3.2 m/s
Housing	rectangular housing, plastic red; round housing, steel	
Sensor cable	PUR	
Operating temperature	-10 ... +70 °C	
Storage temperature	-30 ... +80 °C	
Humidity	100 % rh	condensation permitted
Protection category	IP67	
Vibration resistance	10 g/50 Hz	
Max. measuring length	infinite	in steps of 90 m

Electrical data

Feature	Technical data	Additional information
Operating voltage	24 V DC ±20 % 5 V DC ±5 %	reverse-polarity protection on UB no reverse-polarity protection on UB
Current consumption	max. 70 mA	24 V no load
Type of connection	flying leads round connector D-SUB 9-pin	
Output circuit	PP LD TTL	PP only with 24 V
Output signals	A, /A, B, /B, Option: I, /I, or R, /R	quadrature signal
Pulse width of reference signal	1 increment	
Resolution	0.04, 0.05, 0.08, 0.1, 0.16, 0.2, 0.8 mm	
Jitter	<15 %	with reading distance of 0.5 mm
Interference protection class	3	according to IEC 801
Real-time requirement	real-time signal processing	
Signal level high	>UB - 2.5 V >2.5 V >2.4 V	with PP with LD with TTL
Signal level low	<0.8 V <0.5 V <0.4 V	with PP with LD with TTL

Signal forms

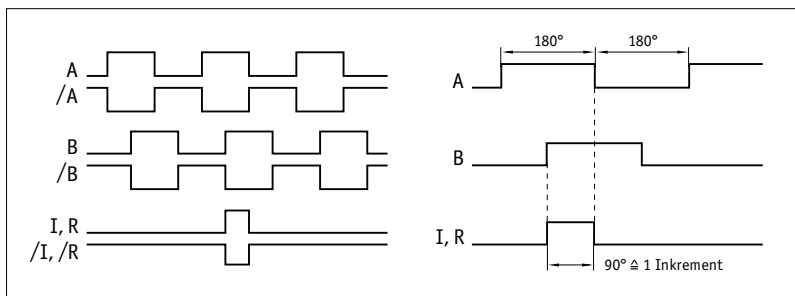

! The logical condition of signals A and B is not defined in reference to the index signal I or the reference signal R. It can deviate from the signal form.

Pin assignment

non-inverted

signal	E1	E6X	E8X
A	red	3	3
B	orange	4	4
+UB	brown	2	2
GND	black	1	1
N.C.		5,6,7	5,6,7,8,9

inverted

signal	E1	E6X	E8X
A	red	1	1
B	orange	2	2
+UB	brown	4	4
GND	black	5	5
A/	yellow	6	6
B/	green	7	7
N.C.		3	3, 8, 9

inverted with reference signal

signal	E1	E6X	E8X
A	red	1	1
B	orange	2	2
I	blue	3	3
+UB	brown	4	4
GND	black	5	5
A/	yellow	6	6
B/	green	7	7
I/	violet	8	8
N.C.			9

Mounting instruction

On systems with reference points on the magnetic band, please ensure the correct alignment of the sensor and band (see diagram).

Reference signal	O, I	R
Sensor/band reading distance A	max. 2 mm	max. 1.5 mm
Lateral offset B	max. ±2 mm	max. ±0.5 mm

Sensor/band reading distance (symbolic sensor representation)

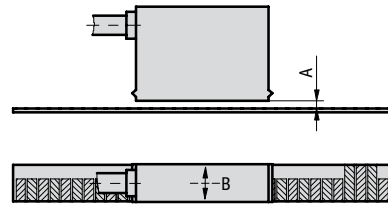

Order

Order table

Feature	Order data	Specifications	Additional information
Operating voltage	4	24 V DC ±20 %	reverse-polarity protection
	5	5 V DC ±5 %	
Sensor design	A	rectangular	
	F	round	
Type of connection	E1	flying leads, 2 m cable	
	E6X	round connector without mating connectors	
	E8X	D-SUB 9-pin without mating connectors	
		cable extensions on request	
Cable length L	...	D 1 ... 20 m, in steps of 1 m	
Output circuit	PP	push-pull	only operating voltage 4
	LD	line driver	
	TTL		only with non-inverted output signal, max. cable length 5 m
Output signal	NI	non-inverted	with reference signal I or R
	I	inverted	
Reference signal	O	without	not possible with resolution 0.8 mm
	I	index periodic	
	R	index fixed	
Resolution	...	H 0.05, 0.1, 0.2, 0.8, 0.04, 0.08, 0.16	F design only possible with resolutions 0.1, 0.2

Order code

MSK320 - - - - - - - -

Scope of delivery: MSK320, User information, Allen fastening screws M3 x 14 mm ISO 4762, lock washers M3 DIN 7980, strain relief for sensor cable

➔ **Additional information:**

Short Description, Technical Details
Product Overview

Page 46 cont.
Page 4 cont.

Profile

- Max. resolution up to 1 μm
- Repeat accuracy $\pm 0.01\text{ mm}$
- Status LED display
- Works with magnetic band MB500
- Reading distance up to 2 mm



5.2

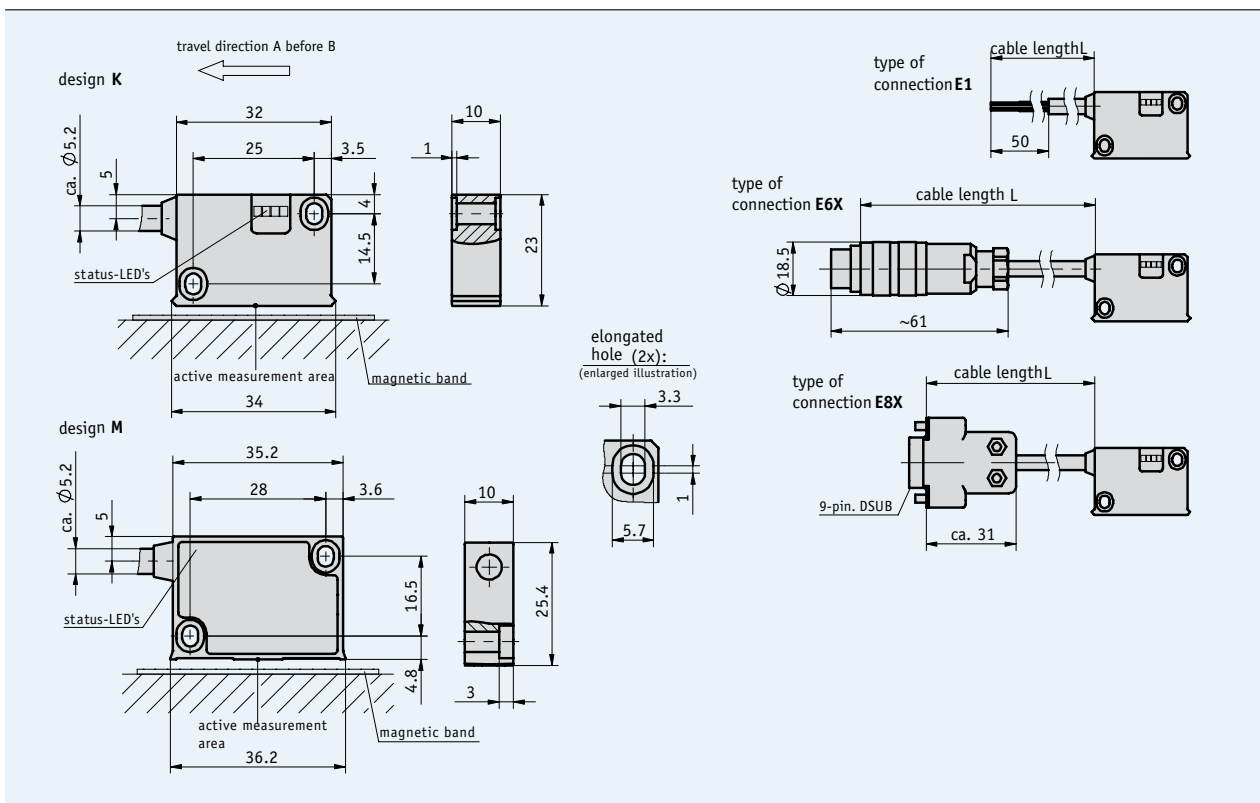

Mechanical data

Feature	Technical data	Additional information
Scale embodiment	MB500	
System accuracy	$\pm(0.025 + 0.01 \times L)$ mm, L in m	
Repeat accuracy	max. ± 0.01 mm	
Sensor/band reading distance	0.1 ... 2 mm 0.1 ... 1.5 mm	with reference signals O, I with reference signal R
Travel speed	depends on resolution and pulse interval	see table
Housing	plastic black	
Sensor cable	PUR	drag chain-compatible
Operating temperature	-10 ... +70 °C	
Storage temperature	-30 ... +80 °C	
Humidity	100 % rh	condensation permitted
Protection category	IP67	
Vibration resistance	10 g/50 Hz	
Max. measuring length	infinite	

Travel speed

Resolution (mm)		Travel speed V_{max} (m/s)										
		0.001	0.005	0.010	0.025	0.050	0.100	0.200	0.500	1.000	2.000	4.000
Pulse interval (μs)	0.001	4.00	1.60	0.80	0.32	0.20	0.10	0.05	0.03	0.01		
	0.005	20.00	8.00	4.00	1.60	1.00	0.50	0.25	0.13	0.06		
	0.010	25.00	16.00	8.00	3.20	2.00	1.00	0.50	0.25	0.12		
	0.025	25.00	25.00	20.00	8.00	5.00	2.50	1.25	0.63	0.30		
	0.050	25.00	25.00	25.00	16.00	10.00	5.00	2.50	1.25	0.61		
Counting frequency (kHz)	0.100	25.00	25.00	25.00	25.00	20.00	10.00	5.00	2.50	1.21		
	0.20	0.20	0.50	1.00	2.50	4.00	8.00	16.00	32.00	66.00		
		1250.00	500.00	250.00	100.00	62.50	31.25	15.63	7.81	3.79		

Electrical data

Feature	Technical data	Additional information
Operating voltage	6.5 V DC ... 30 V DC 4.75 V DC ... 6 V DC	reverse-polarity protection on UB no reverse-polarity protection on UB
Current consumption	<25 mA	no load
Type of connection	flying leads round connector D-SUB 9-pin	
Output circuit	PP LD	
Output signals	A, /A, B, /B, Option: I, /I or R, /R	
Pulse width of reference signal	1 or 4 increments	
Resolution	0.001, 0.005, 0.01, 0.025, 0.05, 0.1 mm	
Interference protection class	3	IEC-61000-6-2
Real-time requirement	real-time signal processing	
Signal level high	>UB - 2.5 V >2.5 V	with PP with LD
Signal level low	<0.8 V	

■ Signal forms

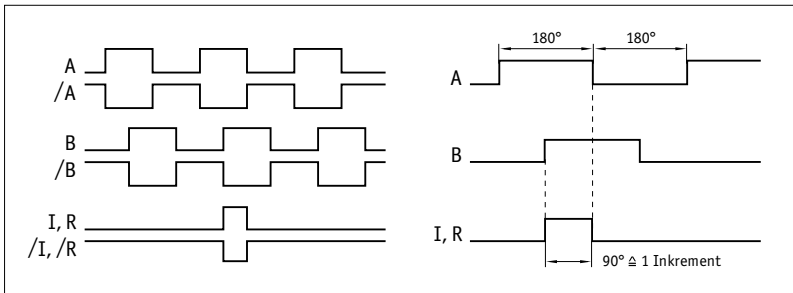

! The logical condition of signals A and B is not defined in reference to the index signal I or the reference signal R. It can deviate from the signal form.

■ Pulse interval

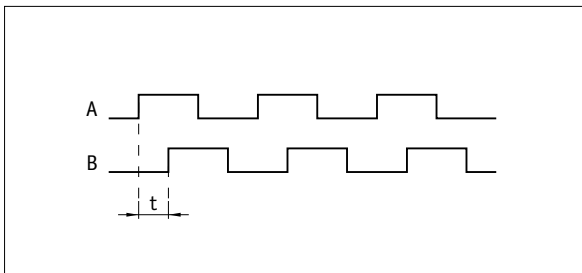

Example: Pulse interval t = 1 μs
(i.e., the downstream unit must be able to process 250 kHz)

$$\text{Formula for counting frequency} = \frac{1}{1 \mu\text{s} \times 4} = 250 \text{ kHz}$$

Pin assignment

■ inverted without index signal

Signal	E1	E6X	E8X
A	red	1	1
B	orange	2	2
+UB	brown	4	4
GND	black	5	5
/A	yellow	6	6
/B	green	7	7
N.C.		3	3, 8, 9

■ inverted with index signal

signal	E1	E6X	E8X
A	red	1	1
B	orange	2	2
I, R	blue	3	3
+UB	brown	4	4
GND	black	5	5
/A	yellow	6	6
/B	green	7	7
/I, /R	violet	8	8
N.C.			9

Mounting instruction

On systems with reference points on the magnetic band, please ensure the correct alignment of the sensor and band (see diagram).

Reference signal	O, I	R
Sensor/band reading distance A	max. 2 mm	max. 1.5 mm
Lateral offset B	max. ± 2 mm	max. ± 0.5 mm

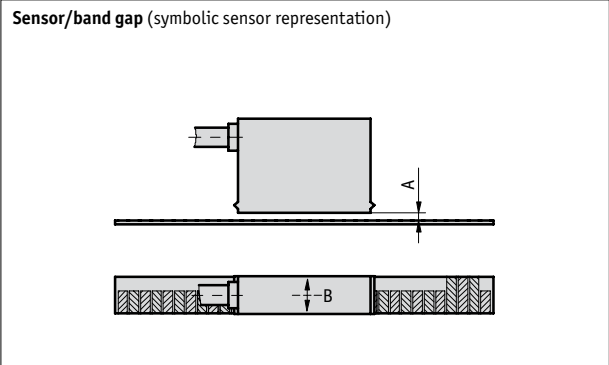

Order

Order table

Feature	Order data	Specifications	Additional information
Operating voltage	10	6.5 ... 30 V DC	
	11	4,75 ... 6 V DC	
Design	K	plastic housing	
	M	metal housing	
Type of connection	E1	flying leads, 2 m cable	
	E6X	round connector without mating connectors	
	E8X	D-SUB 9-pin without mating connectors	
		cable extensions on request	
Cable length L	...	1 ... 20 m, in steps of 1 m	
Output circuit	PP	push-pull	only operating voltage 10
	LD	line driver	
Reference signal	O	without	
	I	index periodic	
	R	fixed reference	
Resolution	...	0.001, 0.005, 0.010, 0.025, 0.050, 0.1	
Pulse interval in μs	...	0.2, 0.5, 1, 2.5, 4, 8, 16, 32, 66	

Order code

MSK5000 - - - - - - - -

A B C D E F G H

Scope of delivery: MSK5000, User information, Allen fastening screws M3 x 14 mm ISO 4762, lock washers M3 DIN 7980, strain relief for sensor cable, distance gage 0.8 mm

Additional information:

Short Description, Technical Details
Product Overview

Page 46 cont.
Page 4 cont.

Magnetic Sensor MS500

Incremental, miniature design

Profile

- Compact design of sensor and connector
- To be connected to MA502, MA506 or AS510/1
- Works with magnetic band MB500
- Max. sensor/band reading distance 2 mm

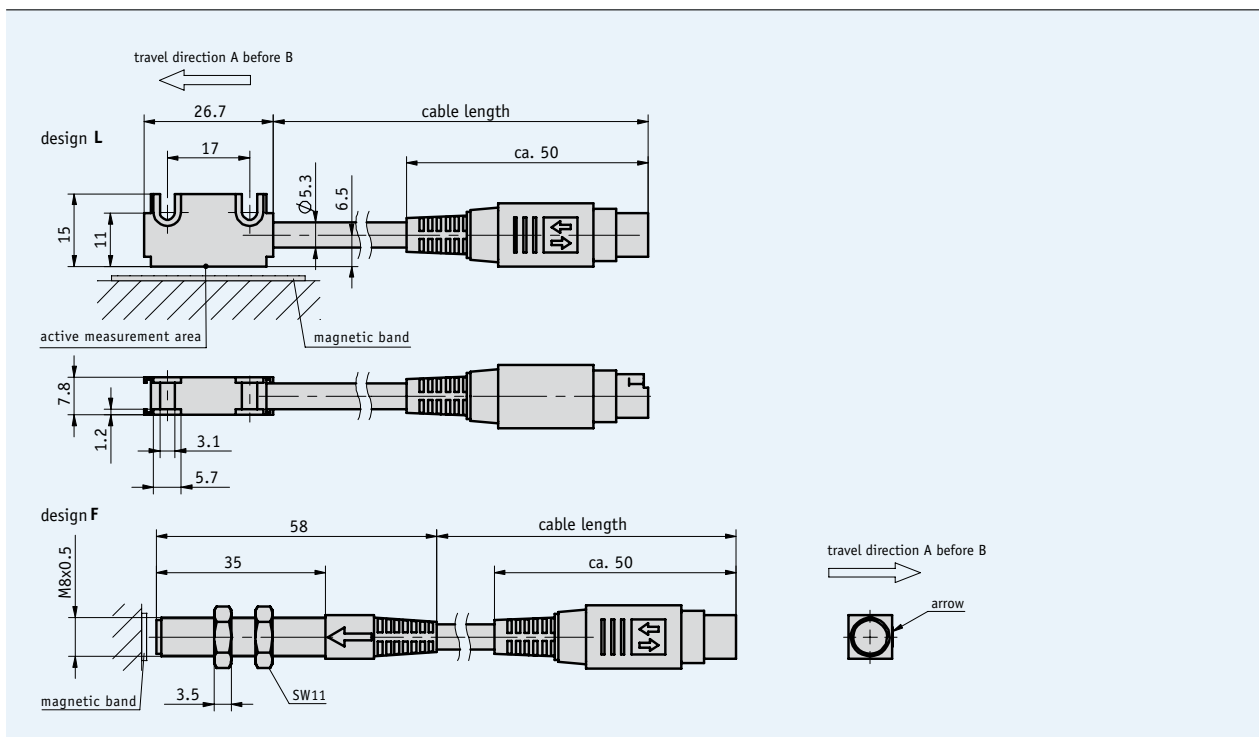

Mechanical data

Feature	Technical data	Additional information
Scale embodiment	MB500	
System accuracy	depends on downstream electronics unit	
Repeat accuracy	depends on downstream electronics unit	
Sensor/band reading distance	0.1 ... 2 mm	
Travel speed	depends on downstream electronics unit	
Housing	aluminum, varnished red steel	sensor design L sensor design F
Sensor cable	PVC	drag chain-compatible
Operating temperature	-20 ... +70 °C (sensor) 0 ... +60 °C (connector)	
Storage temperature	-20 ... +85 °C	
Humidity	100 % rh	condensation permitted
Protection category	IP67	
Vibration resistance	5 ... 2000 Hz bei 20 g	
Shock resistance	200 g at 11 m/s	
Max. measuring length	infinite	

Electrical data

Feature	Technical data	Additional information
Operating voltage	feed via magnetic display/ downstream electronics unit	
Current consumption	depends on magnetic display/ downstream electronics unit	
Type of connection	Mini-DIN 6-pin	
Interference protection class	3	according to IEC 801
Real-time requirement	real-time signal processing	

Mounting instruction

Sensor/band reading distance A	max. 2 mm
Lateral offset B	max. ±2 mm

 The connection must not be changed (e.g., different cable, cable length ...)

Sensor/band reading distance (symbolic sensor representation)

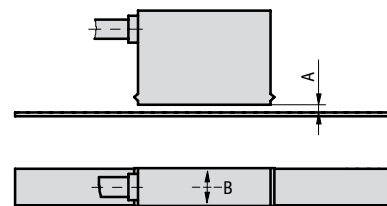

5.2

Order

Order table

Feature	Order data	Specifications	Additional information
Sensor design	L	rectangular	
	F	round	
Cable sheath	PVC	oil-resistant	
	PUR		
Cable length L	...	1 ... 20 m, in steps of 1 m	

Order code

MS500 - - -

Scope of delivery: MS500, User information, Allen fastening screws M3 x 14 mm ISO 4762, lock washers M3 DIN 7980, strain relief for sensor cable

 **Additional information:**

Short Description, Technical Details
Product Overview

Page 46 cont.
Page 4 cont.

Profile

- Max. display accuracy 10 µm
- High-contrast LCD, 12-digit LCD dot matrix
- Incremental measurement and reset function
- Option: serial interface RS232/RS485
- Option: 2 measurement channels
- Programmable actual-value memory
- Works with sensor MS500

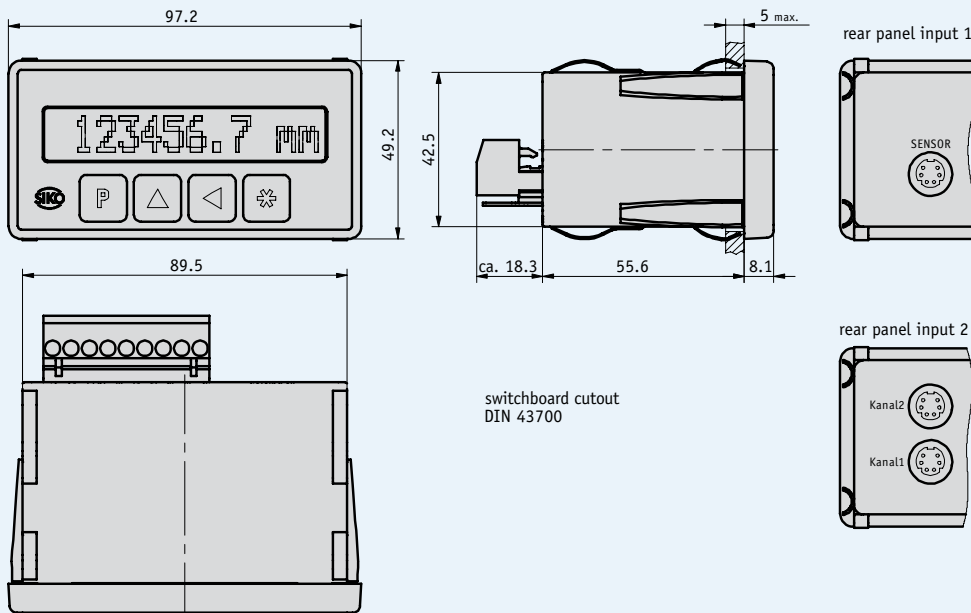

Mechanical data

Feature	Technical data	Additional information
System accuracy	$\pm(0.05 + 0.01 \times L)$ mm, L in m	at $T_U = 20$ °C
Repeat accuracy	± 1 digit	
Magnetic sensor	MS500	incremental
Supply connection	9-pin screw-type terminal strip	
Calibration input connection	9-pin screw-type terminal strip	
Sensor connection	mini-DIN	
Display/display range	12-digit LCD dot matrix	-9 999 999 ... 9 999 999, sign, units
Sensor travel speed	5 m/s	with reading distance of 0.1 ... 2 mm
Design	panel-mount housing cut-out 92 x 45 mm	Noryl GFN 2SE 1, snap module
Housing	plastic black	
Protection category	IP40 according to DIN 40050 for whole device	IP60 according to DIN 40050 with switchboard installation
Operating temperature	0 ... +50 °C	
Storage temperature	-20 ... +80 °C	
Humidity	95 % rh	condensation inadmissible

Electrical data

Feature	Technical data	Additional information
Operating voltage	24 V DC ±20 % 230 V AC ±10 % 115 V AC ±10 %	
Current consumption	70 mA 20 mA 10 mA	24 V, incl. sensor 115 V, incl. sensor 230 V, incl. sensor
Interfaces/protocol	RS232 with standard protocol RS485 with standard protocol	
Resolution	0.01, 0.1, 1, 10 0°–90°–0° / 0°–360°	linear path measurement, in mm angle measurement, max. 0.001°
Interference protection class	3	according to IEC 801
Switching output	with or without	

Pin assignment

panel-mount housing EG

signal	PIN	signal	PIN
Reset	1	TXD (RS232); DÜA(RS485); A1 (switching output)	6
UB= +24 V for calibration input	2	PE	7
GND	3	GND (24 V DC)	8
N.C.	4	N (230/115 V AC)	9
RXD (RS232); DÜB (RS485); A2 (switching output)	5	UB (24 V DC)	
		L (230/115 V AC)	

5.2

Order

Order table

Feature	Order data	Specifications	Additional information
Operating voltage	1	230 V AC ±10 %	
	2	115 V AC ±10 %	
	4	24 V DC ±20 %	
Interface/protocol	XX/XX	without	
	S1/00	RS232 with standard protocol	
	S3/00	RS485 with standard protocol	
Switching output	S0	without	
	SM	with	only with interface XX/XX
Input	1	one channel	
	2	two channels	
Software	S		
	SW01	for two channels	

Order code

MA502 - EG - A - RM - B - C - D - E

Scope of delivery: MA502, User information

Additional information:

Short Description, Technical Details
Product Overview

Page 46 cont.
Page 4 cont.

Profile

- Max. display accuracy 10 µm
- Small design
- Incremental measurement function
- Works with sensor MS500
- Reference input

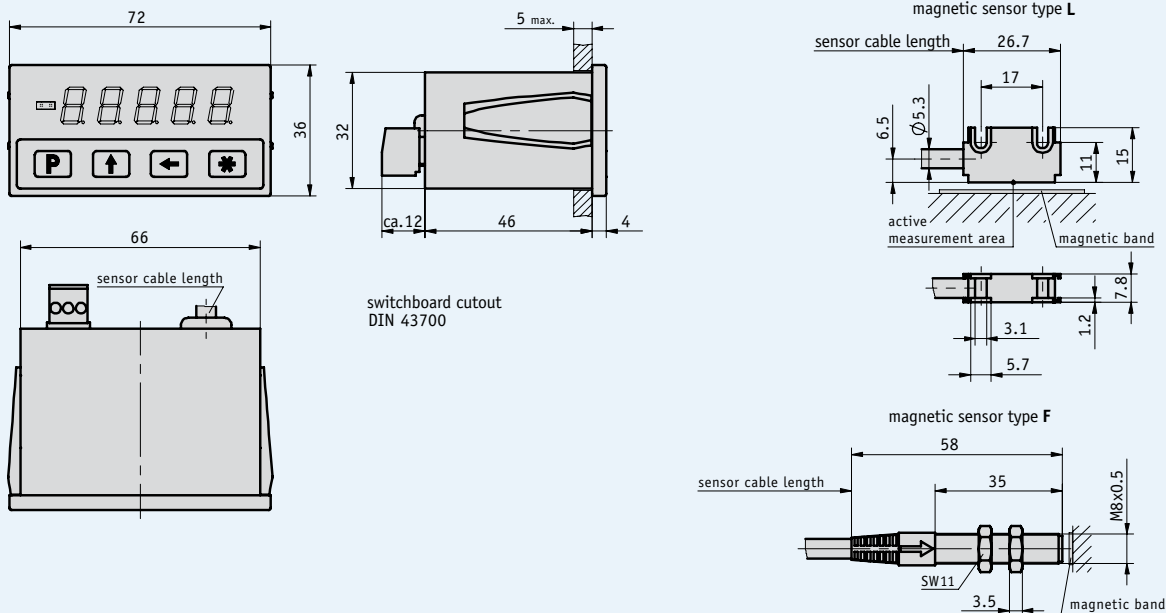

Mechanical data

Feature	Technical data	Additional information
System accuracy	$\pm(0.1+0.01 \times L)$ mm, L in mm	at $T_U = 20$ °C
Repeat accuracy	± 1 digit	
Supply connection	3-pin terminal strip	
Display/display range	5-digit LED, red, 10 mm	-99 999 ... 99 999
Sensor travel speed	5 m/s	with reading distance of 0.1 ... 2 mm
Design	panel-mount housing, cutout 68 x 33 mm bench-top housing	plastic, red transparent, snap module aluminum profile, black anodized
Protection category	IP40 according to DIN 40050 for whole device	IP60 according to DIN 40050 with switchboard installation
Operating temperature	-10 ... +70 °C	
Storage temperature	-30 ... +80 °C	
Humidity	max. 95 % rh	condensation inadmissible

Electrical data

Feature	Technical data	Additional information
Operating voltage	24 V DC ±20 % 230 V AC -10/+6 %	only with TGL with 24 V DC
Current consumption	<60 mA	
Resolution	in mm 0.01, 0.05, 0.1, 1	in inch 0.001, 0.01 programmable angle display
Interference protection class	3	according to IEC 801

Pin assignment

Signal
GND
+UB
Reset

Order

Order table

Feature	Order data	Specifications	Additional information
Operating voltage	4	24 V DC ±20 %	
	1	230 V bench-top housing design on request	
Sensor connection	S	pluggable	delivery without sensor MS500
	M	hard-wired	
Type of magnetic sensor	OS	without sensor	only with sensor connection "S"
	L	L design	
	F	F design	
Sensor cable length	...	1 ... 20 m, in steps of 1 m	only with sensor connection M

Order code

MA506 - EG - - - -

A B C D

Scope of delivery: MA506, User information

Additional information:

Short Description, Technical Details
Product Overview

Page 46 cont.
Page 4 cont.

Profile

- Parameters adjustable via DIP switches
- Resolution up to 1 µm
- Reference signal with intervals of 5 mm
- Works with sensor MS500

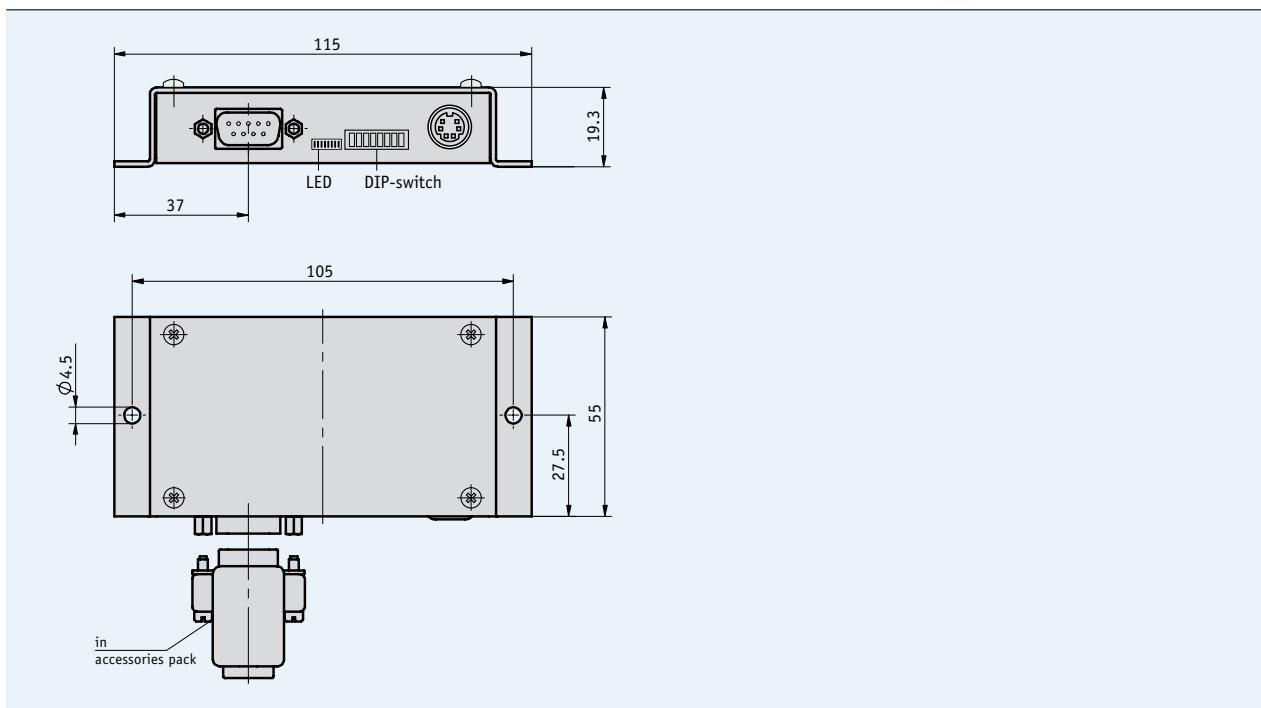

Mechanical data

Feature	Technical data	Additional information
System accuracy	$\pm(0.025 + 0.01 \times L)$ mm, L in m	at $T_U = 20$ °C (with MB500 and 0.05 mm accuracy class)
Repeat accuracy	± 1 increment	
Housing	sheet steel	electrogalvanized
Cable length of connection line	max. 50 m	acc. to RS422 specification
Electrical connection	D-SUB 9-pin for supply and signal output	DIN mini-connector for sensor
Protection category	IP 40 according to DIN VDE 0470	
Humidity of translation module	max. 95 % rh	condensation inadmissible
Operating temperature	0 ... +70 °C	
Storage temperature	-20 ... +70 °C	
Weight	approx. 400 g	
Sensor travel speed	max. 20 m/s	

Electrical data

Feature	Technical data	Additional information
Operating voltage	24 V DC $\pm 20\%$ 5 V DC $\pm 5\%$	reverse-polarity protection no reverse-polarity protection
Current consumption	<70 mA	
Resolution (μm)	5, 10, 20, 25, 50, 100	with quadrature evaluation DIP switch-selectable
Output signals	quadrature A, B, O	each inverted
Output circuit	PP, LD (RS422)	switch-selectable via DIP switches
Real-time requirement	real-time signal processing	
Interference protection class	3	according to IEC 801

Pin assignment

Signal	PIN
A	1
A/	2
GND (for output signals)	3
B	4
B/	5
O/	6
=	7
+ UB	8
GND (for supply)	9

5.2

Order

Order table

Feature	Order data	Specifications	Additional information
Operating voltage	4	24 V DC $\pm 20\%$	reverse-polarity protection
	5	5 V DC $\pm 5\%$	no reverse-polarity protection

Order code

AS510/1 -

Scope of delivery: AS510/1, User information

Additional information:

Short Description, Technical Details
Product Overview

Page 46 cont.
Page 4 cont.

Profile

- Easy adhesive mounting, self-assembly possible

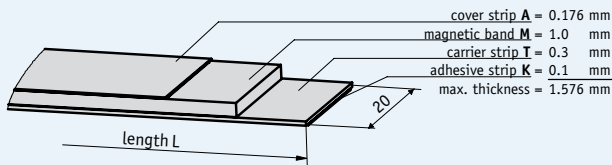

5.2

Mechanical data

Feature	Technical data	Additional information
Measuring length	max. 5120 mm	
Band width	20 mm	
Thickness	1.4 mm	without cover strip
Accuracy class	±50 µm	bei T _U = 20 °C
Temperature coefficient	(11±1) × 10 ⁻⁶ /K	
Operating temperature	-20 ... +70 °C	
Storage temperature	-40 ... +70 °C	
Humidity	100 % rh	condensation permitted
Mounting type	glued joint	pre-assembled double-sided adhesive strip
Cover strip material	stainless steel	

Order

The necessary band length is calculated as follows:
 Measured path + sensor length "S" + (2 x lead-in and lead-out "B"). Sensor length "S" refer to the drawing of the employed sensor, lead-in and lead-out "B" = 5 mm.

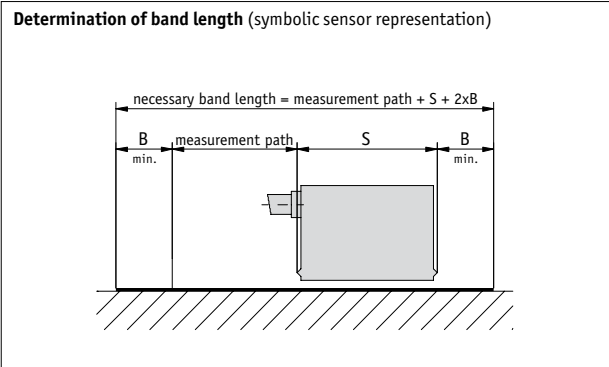

■ **Order table**

Feature	Order data	Specifications	Additional information
Length of magnetic band	... A	0.2 ... 75 m, in steps of 0.1 m	Order information, see "Determination of band length"
Adhesive carrier strip	TM B	with	
	TO B	without	
Cover strip	AM C	with	
	AO C	without	

■ **Order code**

MBA - - -
 A **B** **C**

Scope of delivery: MBA, User information

Accessories:
 Profile rail PSA

Page 180

Additional information:
 Short Description, Technical Details
 Product Overview

Page 46 cont.
 Page 4 cont.

Profile

- Easy adhesive mounting, self-assembly possible

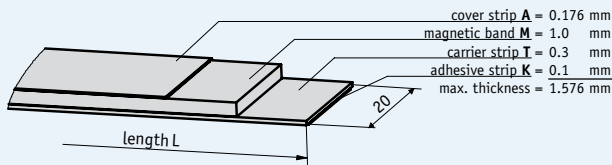

5.2

Mechanical data

Feature	Technical data	Additional information
Measuring length	max. 20480 mm	
Band width	20 mm	
Thickness	1.4 mm	without cover strip
Accuracy class	±100 µm	at T ₀ = 20 °C
Temperature coefficient	(11±1) × 10 ⁻⁶ /K	
Operating temperature	-20 ... +70 °C	
Storage temperature	-40 ... +70 °C	
Humidity	100 % rh	condensation permitted
Mounting type	glued joint	pre-assembled double-sided adhesive strip
Cover strip material	stainless steel	

Order

The necessary band length is calculated as follows:
 Measured path + sensor length "S" + (2 x lead-in and lead-out "B"). Sensor length "S" refer to the drawing of the employed sensor, lead-in and lead-out "B" = 5 mm.

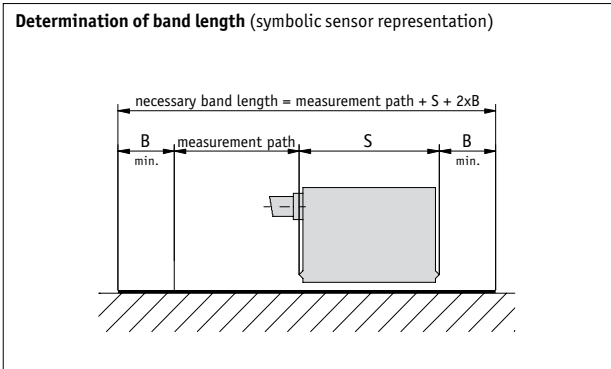

■ **Order table**

Feature	Order data	Specifications	Additional information
Length of magnetic band	... A	0.5 ... 90 m, in steps of 0.1 m	Order information, see "Determination of band length"
Adhesive carrier strip	TM B	with	
	TO B	without	
Cover strip	AM C	with	
	AO C	without	

■ **Order code**

MBA511 - - -
 A B C

Scope of delivery: MBA511, User information

Accessories:
 Profile rail PSA

Page 180

Additional information:
 Short Description, Technical Details
 Product Overview

Page 46 cont.
 Page 4 cont.

Profile

- To be connected to magnetic displays MA505 and MA561 as well as translation module AEA
- Max. resolution depends on downstream electronics unit
- Repeat accuracy depends on downstream electronics unit
- Max. sensor/band reading distance of 1 mm
- Max. measuring length 5120 mm

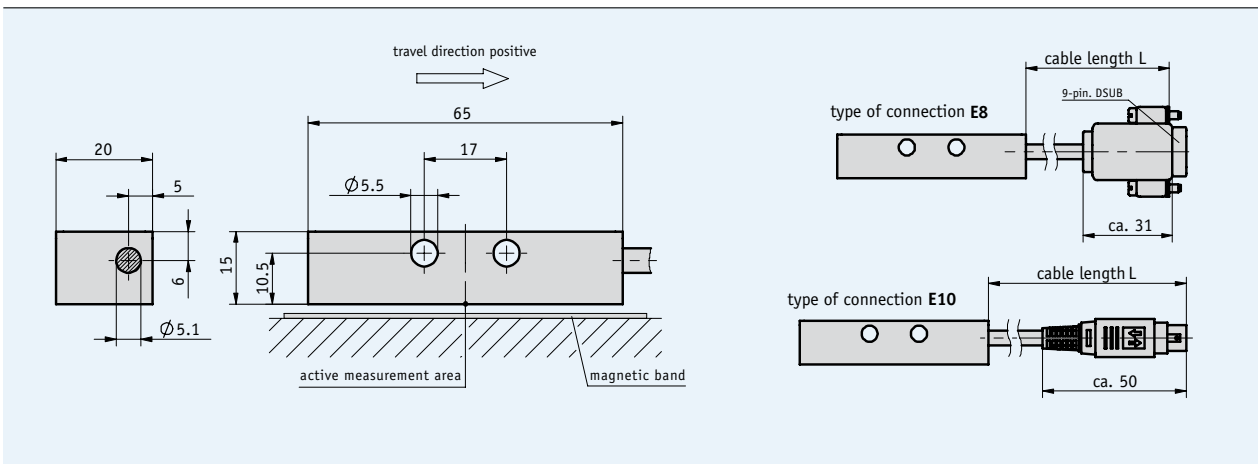

Mechanical data

Feature	Technical data	Additional information
Scale embodiment	MBA	
System accuracy	$(0.05 + 0.03 \times L)$, L in m	
Repeat accuracy	0.01 mm	
Sensor/band reading distance	max. 1 mm	
Travel speed	max. 5 m/s	
Housing	aluminum natural chromated	
Sensor cable	PVC	
Operating temperature	0 ... +60 °C	
Storage temperature	-20 ... +80 °C	
Humidity	100 % rh	condensation permitted
Protection category	IP67	DIN 40050
Vibration resistance	10 g/50 Hz	
Max. measuring length	max. 5120 mm	

Electrical data

Feature	Technical data	Additional information
Operating voltage	feed via downstream electronics unit	
Current consumption	see downstream electronics unit	
Type of connection	Mini-DIN, D-SUB 9-pin	
Resolution	depends on magnetic display, downstream electronics unit	

Pin assignment

signal	E8	E10
LK14-A	2	1
SENS- DATA	3	3
LK14-B	4	5
CLK	6	4
+5V	7	8
GND	8	6
STR	9	7
N.C.	1, 5	2

Mounting instruction

When installing the sensor and magnetic band, always ensure that both system components are correctly aligned. The arrows marked on the band and sensor must point in the same direction during installation.

Sensor/band reading distance A	max. 1.0 mm
Lateral offset B	max. ±1 mm

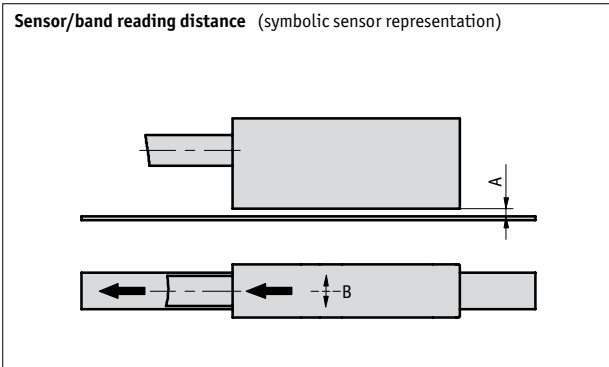

5.2

Order

Order note

This sensor is sold in Switzerland and Austria under the product name "AMSA".

Order table

Feature	Order data	Specifications	Additional information
Type of connection	E8	A	D-SUB 9-pin
	E10	A	Mini-DIN
Cable length L	...	B	1 ... 20 m, in steps of 1 m

Order code

MSA - A - A - B

Scope of delivery: MSA, User information, distance gage 0.5 mm, snap ferrite on sensor cable

Additional information:

Short Description, Technical Details
Product Overview

Page 46 cont.
Page 4 cont.

Magnetic Sensor MSA510/1

Absolute, SSI interface, resolution 10 μm

Profile

- Max. resolution of 10 μm
- Repeat accuracy of 0.01 mm
- SSI, RS485 output circuits
- Max. sensor/band reading distance 1 mm
- Max. measuring length 5120 mm

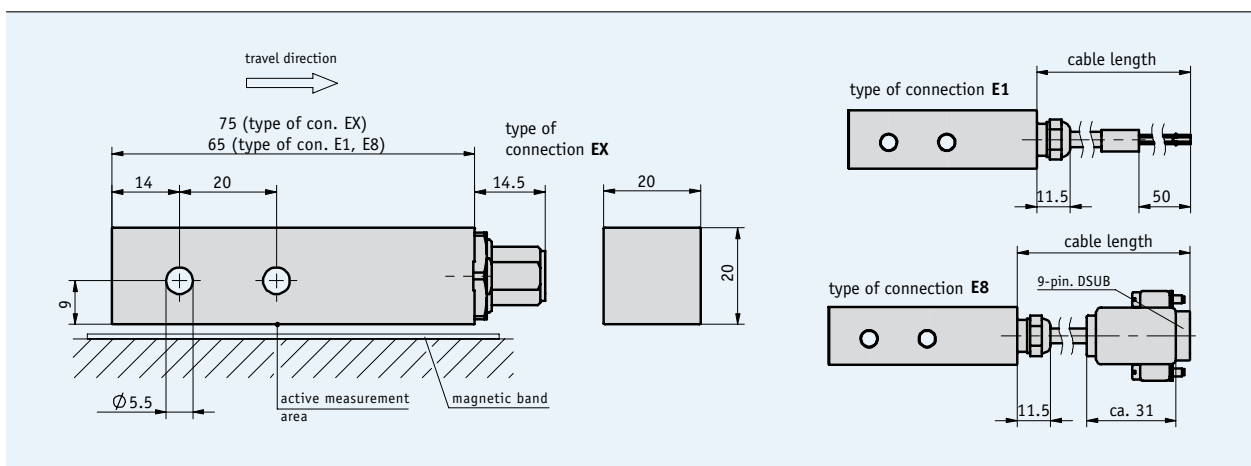

Mechanical data

Feature	Technical data	Additional information
Scale embodiment	MBA	
System accuracy	$\pm(0.05 + 0.03 \times L)$ mm, L in m	at $T_U = 20^\circ\text{C}$
Repeat accuracy	max. 0.01 mm	
Sensor/band reading distance	max. 1 mm	
Travel speed	max. 5 m/s	
Housing	aluminum	
Sensor cable	PVC	option: drag chain-compatible cable
Operating temperature	0 ... +60 $^\circ\text{C}$	
Storage temperature	-30 ... +85 $^\circ\text{C}$	
Humidity	100 % rh	condensation permitted
Protection category	IP65	
Vibration resistance	10 g/50 Hz	
Max. measuring length	max. 5120 mm	

Scope of delivery: MSA510/1, User information, distance gage 0.5 mm

Accessories:

Mating connectors

Page 171

Cable extension KV08S2

Page 173

Additional information:

Short Description, Technical Details

Page 46 cont.

Product Overview

Page 4 cont.

Electrical data

Feature	Technical data	Additional information
Operating voltage	10 ... 30 V DC	reverse-polarity protection on UB
Current consumption	<125 mA	
Power input	<3 VA	
Type of connection	round connector on the housing flying leads D-SUB connector	
Output circuit	SSI, RS485	
Resolution	10 µm	other resolutions programmable
Interference protection class	3	according to IEC 801
SSI clock rate	<500 kHz	
Cycle time	<650 µs	

Pin assignment

SSI (according to RS422)

Signal	E1	EX	E8
Zeroing/config.	white	1	4
+UB	brown	2	1
Data+	green	3	3
Data-	yellow	4	8
GND	gray	5	5
Clock+	pink	6	2
Clock-	blue	7	7
N.C.		8	6, 9
Screen	black		

RS485

Signal	E1	EX	E8
Calibration		1	
Configuration	white		4
+UB	brown	2	1
DÜA	green	3	3
DÜB	yellow	4	8
GND	gray	5	5
N.C.	pink		
N.C.	blue		
N.C.		6, 7, 8	2, 6, 7, 9
Screen	black		

Mounting instruction

When installing the sensor and magnetic band, always ensure that both system components are correctly aligned. The arrows marked on the band and sensor must point in the same direction during installation

Sensor/band reading distance A	max. 1 mm
Lateral offset B	max. ±0.5 mm

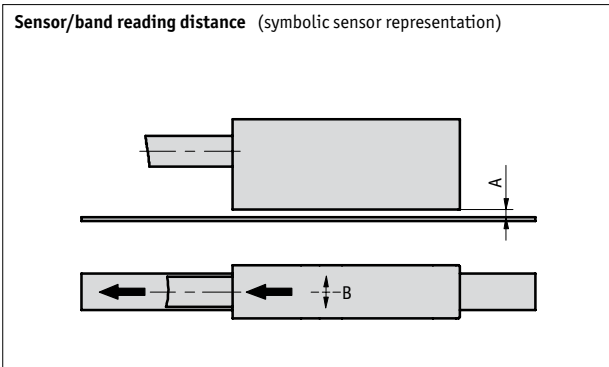

Order

Order note

This sensor is sold in Switzerland and Austria under the product name "AMSA".

Order table

Feature	Order data	Specifications	Additional information
Output circuit	RS485	SIKO standard protocol/SIKONETZ3	bus-compatible
	SSI	incl. RS485 service interface	
Type of connection	EX	without mating connectors, round connector 8-pin	M12, A-coded
	E1	flying leads	
	E8	D-Sub connector	
Cable length L	...	1 ... 20 m, in steps of 1 m	

Order code

MSA510/1 - - -

Magnetic Sensor MSA511

Absolute, SSI interface, resolution 10 μm

Profile

- Max. resolution 10 μm
- Repeat accuracy 0.01 mm
- SSI, RS485 output circuits
- Max. sensor/band reading distance 2 mm
- Max. measuring length 20480 mm

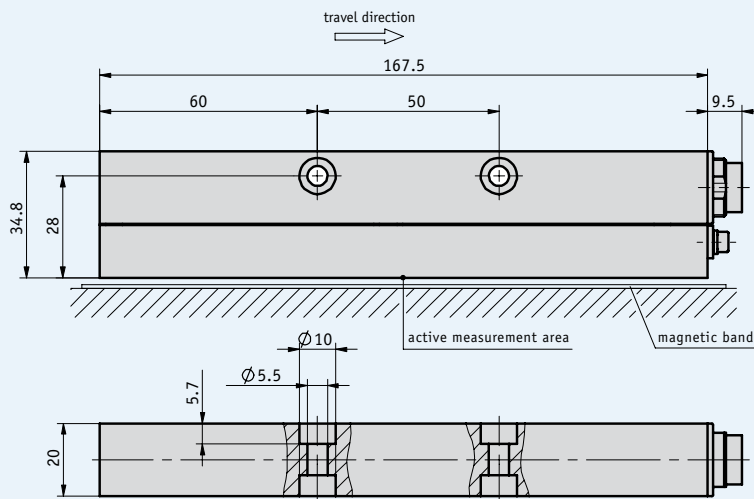

Mechanical data

Feature	Technical data	Additional information
Scale embodiment	MBA511	
System accuracy	$\pm(0.1 + 0.03 \times L)$ mm, L in m	
Repeat accuracy	± 0.01 mm	
Sensor/band reading distance	max. 2 mm	
Travel speed	max. 5 m/s	
Housing	aluminum natural chromated	
Operating temperature	-20 ... +60 °C	
Storage temperature	-20 ... +70 °C	
Humidity	100 % rh	condensation permitted
Protection category	IP65	according to DIN VDE 0470 with a suitable mating connector
Vibration resistance	10 g/50 Hz	
Max. measuring length	20480 mm	

Electrical data

Feature	Technical data	Additional information
Operating voltage	24 V DC ±20 %	reverse-polarity protection on UB
Current consumption	<100 mA	
Power input	<2 V A	
Type of connection	plug connection, 12-pin	
Output circuit	SSI	according to RS422
Output signals	sine, cosine	1 V _{SS} (±100 mV), offset 2.5 V (±100 mV), 5 mm period length
Interfaces	RS485, service interface	
Resolution	10 µm	
Interference protection class	3	according to IEC 801
Baud rate	<500 kHz	
Cycle time	<2 ms	

Pin assignment

SSI (according to RS422)

Signal	
SSI data-	A
SSI data+	B
SSI clock-	C
SSI clock+	D
+24 V DC	E
Sine	F
RS485 DÜA	G
RS485 DÜB	H
GND	J
N.C.	K
Zeroing input	L
Cosine	M

Mounting instruction

When installing the sensor and magnetic band, always ensure that both system components are correctly aligned. The arrows marked on the band and sensor must point in the same direction during installation

Sensor/band reading distance A	max. 2 mm
Lateral offset B	max. ±1 mm

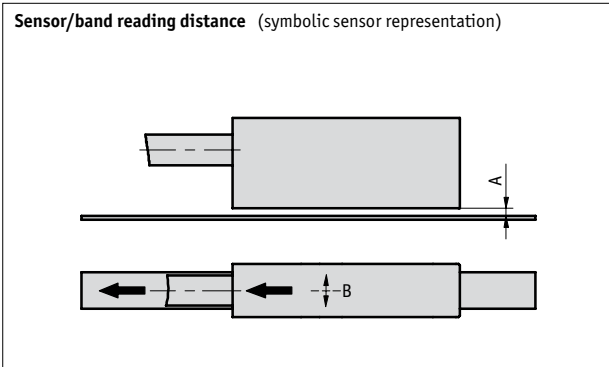

Order

Order note

This sensor is sold in Switzerland and Austria under the product name "AMSA511".

Order code

MSA511 - SSI

Scope of delivery: MSA511, User information

Accessories:

Mating connectors Page 171
Cable extension KV1250 Page 174

Additional information:

Short Description, Technical Details Page 46 cont.
Product Overview Page 4 cont.

Magnetic Display MA505

Absolute, LCD dot matrix display, display accuracy 10 µm

Profile

- Works with sensor MSA
- Max. display accuracy of 10 µm
- Repeat accuracy of ±0.01 mm
- High-contrast LCD, 12-digit dot matrix
- Option: serial interface RS232/RS485

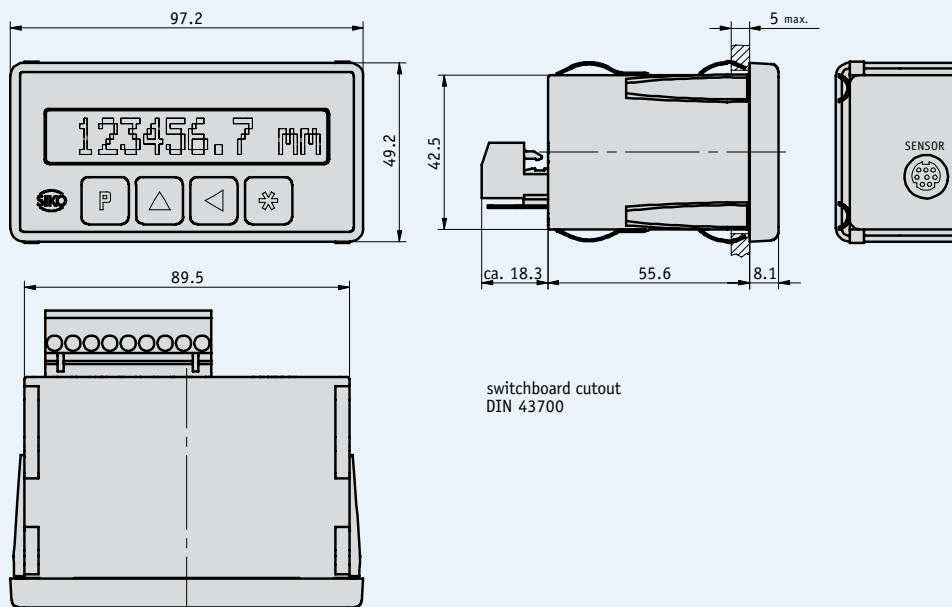

Mechanical data

Feature	Technical data	Additional information
System accuracy	±(0.05+0.03 x L) mm, L in m	at T _U = 20 °C
Repeat accuracy	0.01 mm	
Magnetic sensor	MSA	absolute
Calibration input	9-pin screw-type terminal strip (EG)	
Supply connection	9-pin screw-type terminal strip(EG)	
Sensor connection	pluggable via Mini-DIN	
Display/display range	12-digit LCD dot matrix	-9 999 999 ... 9 999 999, sign, units
Design	panel-mount housing cutout 92 x 45 mm	Noryl GFN 2SE 1, as a snap module
Housing	plastic black	
Protection category	IP40 according to DIN 40050 for whole device	IP60 according to DIN 40050 with switchboard installation
Operating temperature	0 ... +50 °C	
Storage temperature	-20 ... +80 °C	
Humidity	95 % rh	condensation inadmissible

Electrical data

Feature	Technical data	Additional information
Operating voltage	24 V DC ±20 % 230 V AC ±10 % 115 V AC ±10 %	
Current consumption	70 mA 20 mA 10 mA	24 V, incl. sensor 115 V, incl. sensor 230 V, incl. sensor
Interfaces/protocol	without RS232 with standard protocol	others on request
Resolution	in mm 0.01, 0.1, 1, 10 in inch 0.001, 0.01, 0.1, 1	programmable angle display
Interference protection class	3	according to TEC 801

Pin assignment

panel-mount housing EG

Signal	PIN
CAL	1
UB = +12 V for calibration input	2
GND	3
N.C.	4
RXD (RS232); DÜB (RS485); A2 (switching output)	5
TXD (RS232); DÜA (RS485); A1 (switching output)	6
PE	7
GND (24 V DC)	8
N (230/115 V AC)	
UB (24 V DC)	9
L (230/115 V AC)	

Order

Order table

Feature	Order data	Specifications	Additional information
Operating voltage	1	230 V AC ±10 %	
	2	115 V AC ±10 %	
	4	24 V DC ±20 %	
Interface/protocol	XX/XX	without	
	S1/00	RS232 with standard protocol	
	S3/00	RS485 with standard protocol	
Switching output	S0	without	
	SM	with	only with interface XX/XX

Order code

MA505 - EG - A - KM - B - C - S - MSA

Scope of delivery: MA505, User information

Additional information:

Short Description, Technical Details
Product Overview

Page 46 cont.
Page 4 cont.

Profile

- Max. display accuracy 10 µm
- Repeat accuracy ±1 digit, max. ±0.01 mm
- Reference input

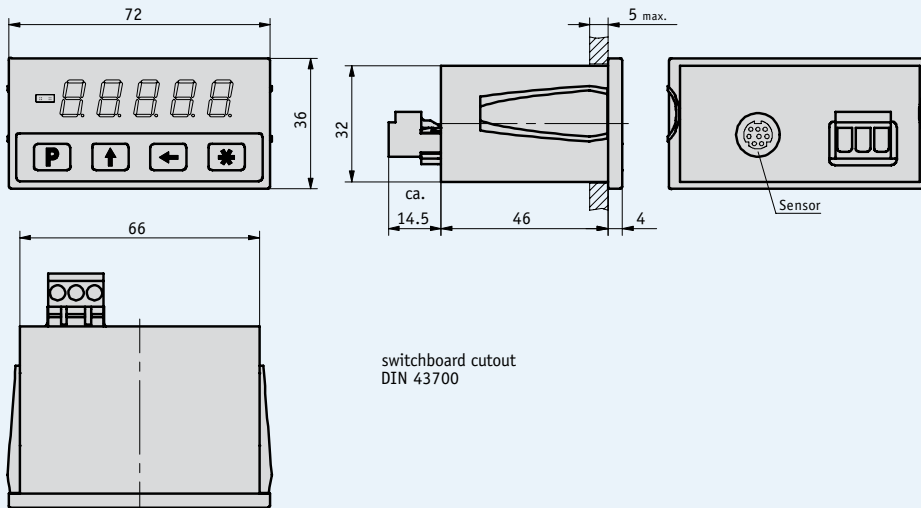

Mechanical data

Feature	Technical data	Additional information
System accuracy	±(0.05 + 0.03 x L) mm, L in m	
Repeat accuracy	±1 digit	max. ±0.01 mm
Magnetic sensor	MSA	
Supply connection	3-pin terminal strip	
Sensor connection	pluggable via Mini-DIN	
Display/display range	5-digit LED, red, 10 mm	-99 999 ...+99 999
Design	panel-mount housing, cutout 68 x 33 mm	
Housing	plastic, red transparent	snap module for switchboard installation
Protection category	IP40 according to DIN 40050 for whole device	IP60 according to DIN 40050 with switchboard installation
Operating temperature	0 ... +50 °C	
Storage temperature	-20 ... +85 °C	
Humidity	max. 95 % rh	condensation inadmissible

Electrical data

Feature	Technical data	Additional information
Operating voltage	10 ... 30 V DC	
Current consumption	<50 mA with 24 V DC	incl. sensor
Resolution	0.01, 0.05, 0.1, 1 mm 0.001 inch, 0.01 inch	programmable angle display
Interference protection class	3	according to IEC 801

Pin assignment

Signal
CAL
+UB
GND

Order

Order code

MA561 - MSA

Scope of delivery: MA561, User information

 **Additional information:**

Short Description, Technical Details
Product Overview

Page 46 cont.
Page 4 cont.

Profile

- Max. resolution 10 µm
- Repeat accuracy 0.01 mm
- SSI, PP parallel, Profibus output circuits
- RS232, RS485 interface options
- Parameters adjustable via DIP switches
- External bus connections can be established (e.g., CAN, Inter-Bus-S ...)



5.2

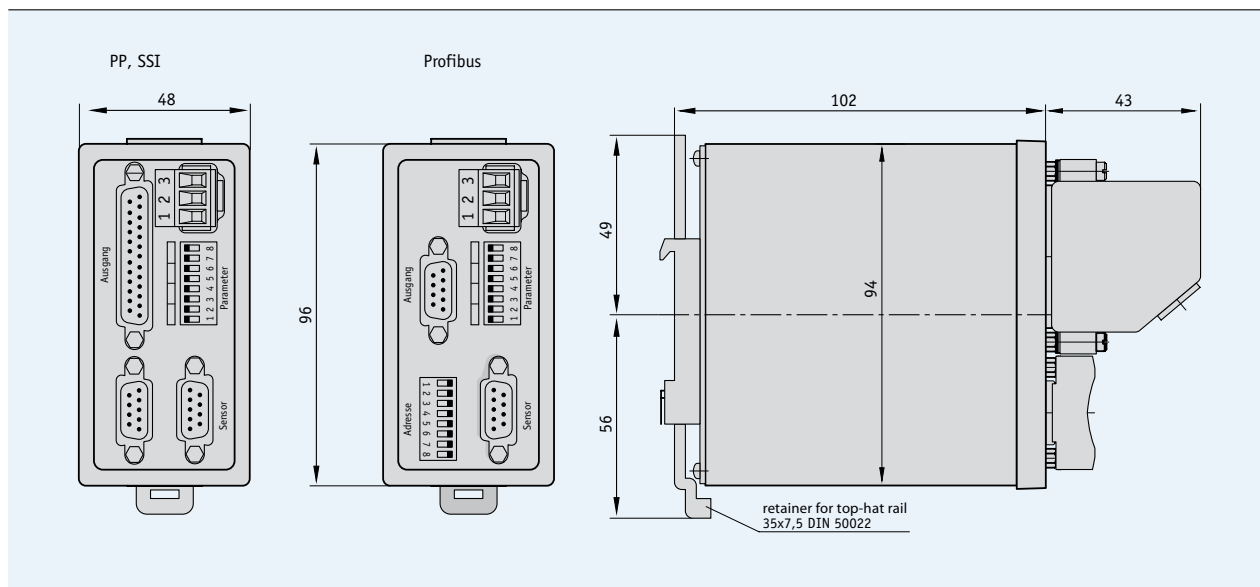

Mechanical data

Feature	Technical data	Additional information
System accuracy	$\pm(0.05 + 0.03 \times L)$ mm, L in m	at $T_U = 20$ °C
Repeat accuracy	0.01 mm	
Housing	aluminum	snap module for top-hat rail mounting
Electrical connection	D-SUB 9-pin for sensor connection D-SUB 9-pin for Profibus connection D-SUB 25-pin for PP/SSI	
Supply connection	3-pin terminal strip	
Protection category	IP 20 according to DIN 40050	
Operating temperature	0 ... +60 °C	
Storage temperature	-20 ... +80 °C	
Weight	approx. 350 g	

Electrical data

Feature	Technical data	Additional information
Operating voltage	24 V DC ±20 %	
Power input	<5 VA	
Resolution	0.01, 0.1, 1, 10 mm	inch 0.001, 0.01, 0.01, 1
Interfaces	RS232 with standard protocol RS485 with standard protocol	
Output circuit	PP parallel/SSI/Profibus	
Interference protection class	3	according to ICE801
SSI clock rate	62.5 – 500 kHz	
Monoflop time	16 µm	
Cycle time	<1 ms	

Pin assignment

SSI

Signal	PIN
SSI-clock +	1
SSI-clock -	2
SSI-data +	3
SSI-data -	4
GND	5
N.C.	6–25

PP, parallel

Signal	PIN
D0	1
D1	2
⋮	⋮
D18	19
D19	20
N.C.	21, 22, 23
GND	24, 25

Power supply

Terminal	PIN
+24 V DC	1
0 V	2
PE	3

Interfaces

RS232	RS485	PIN
RXD	DÜA	3
TXD	GND	5
GND	DÜB	8
N.C.	N.C.	1, 2, 4, 6, 7, 9

5.2

Order

Order table

Feature	Order data	Specifications	Additional information
Output	PP	parallel	
	SSI	synchronous serial interface	
	PB	Profibus	
Interfaces	XX/XX	without	
	S1/00	RS232 with standard protocol	
	S3/00	RS485 with standard protocol	

Order code

AEA - A - 4 - B - MSA

Scope of delivery: AEA, User information,
D-SUB connector 25-pin, D-SUB bush 9-pin

Additional information:

Short Description, Technical Details
Product Overview

Page 46 cont.
Page 4 cont.

Profile

- Max. display accuracy 10 µm
- Repeat accuracy 1 digit
- Freely programmable high-resolution LCD dot matrix display
- Battery-buffered memory
- RS485 interface (option)

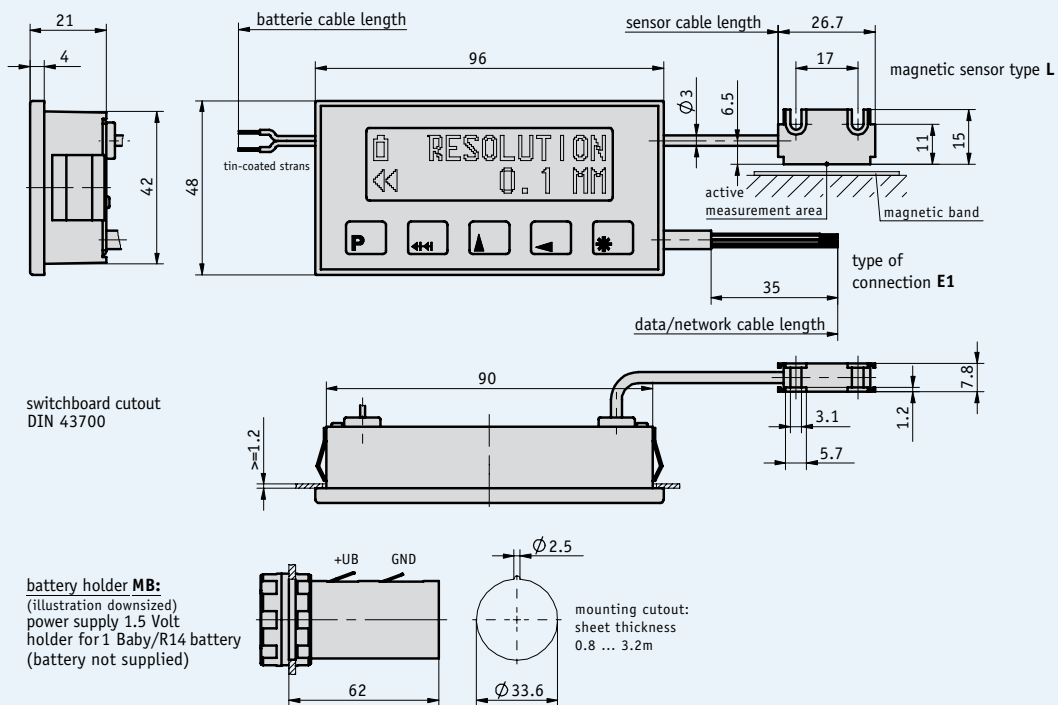

Mechanical data

Feature	Technical data	Additional information
System accuracy	$\pm(0.1 + 0.01 \times L)$, L in m	magnetic band MB500 at $T_U = 20^\circ\text{C}$
Repeat accuracy	± 1 digit	± 0.01 mm
Magnetic sensor	rectangle with elongated hole	hard-wired
Supply connection	cable led to the outside	
Display/display range	2-line dot matrix	-999 999 ... +999 999
Design	panel-mount housing	
Housing	plastic (transparent)	
Protection category	IP54 front side, IP67 sensor	
Operating temperature	0 ... +70 °C	
Storage temperature	-30 ... +80 °C	
Humidity	max. 95 % rh	condensation permitted
Vibration (50 Hz ... 2000 Hz)	<200 m/s ²	
Shock	<300 m/s ²	
Weight	approx. 70 g	
Sensor travel speed	max. 5 m/s	with reading distance of 0.1 ... 2 mm

Electrical data

Feature	Technical data	Additional information
Operating voltage	24 V DC \pm 20 %	
Current consumption	8 mA with 24 V DC active, <0.1 mA with 1.5 V	display switched off DC measurement system active
Interfaces/protocol	RS485 with standard protocol	
Resolution	max. 10 μ m	
Interference protection class	3	according to IEC 61000

Pin assignment

■ with common cable for interface and battery

Signal	E1
GND	black
10 ... 24 V DC/8 mA	brown
1.5 V DC	red
Supply backup	
Data GND	orange
Interface RS485	
Data B	yellow
Interface RS485-DÜB	
Data A	green
Interface RS485-DÜA	

■ with separate cable for interface and battery

Signal	E1	Battery cable
10...24 V DC/8 mA	white	
Data GND	brown	
Data B	yellow	
Data A	green	
GND		black
1.5 V DC		red
24 V DC		
B		
A		
N.C.		

Order

Order table

Feature	Order data	Specifications	Additional information
Sensor cable length	... A	0.3 ... 2 m in steps of 0.1 m	
Data/mains cable length	... B	0.1 ... 2 m in steps of 0.1 m	
Battery cable length	... C	0.2 ... 2 m in steps of 0.1 m	
Interface/protocol	S3/00	RS485 with standard protocol	
	S3/06	RS485/SIKONETZ-3	
	XX/XX	without	
Battery holder	MB	with	provided in the accessories pack
	OB	without	

Order code

MA501 - EG10 - 4 - L - A - E1 - B - C - L - D - S - SF-82990 - E

Scope of delivery: MA501 with sensor, User information, Allen fastening screws M3 x 14 mm ISO 4762, lock washers M3 DIN 7980, strain relief for sensor cable, distance gage 0.8 mm

Additional information:

Short Description, Technical Details
Product Overview

Page 46 cont.
Page 4 cont.

Profile

- Max. display accuracy 10 µm or 1/8 inch
- Repeat accuracy 1 digit – max. ±0.01 mm
- Low-power LCD with decimal and fraction-inch function
- Max. sensor/band reading distance 2 mm
- Battery-buffered memory

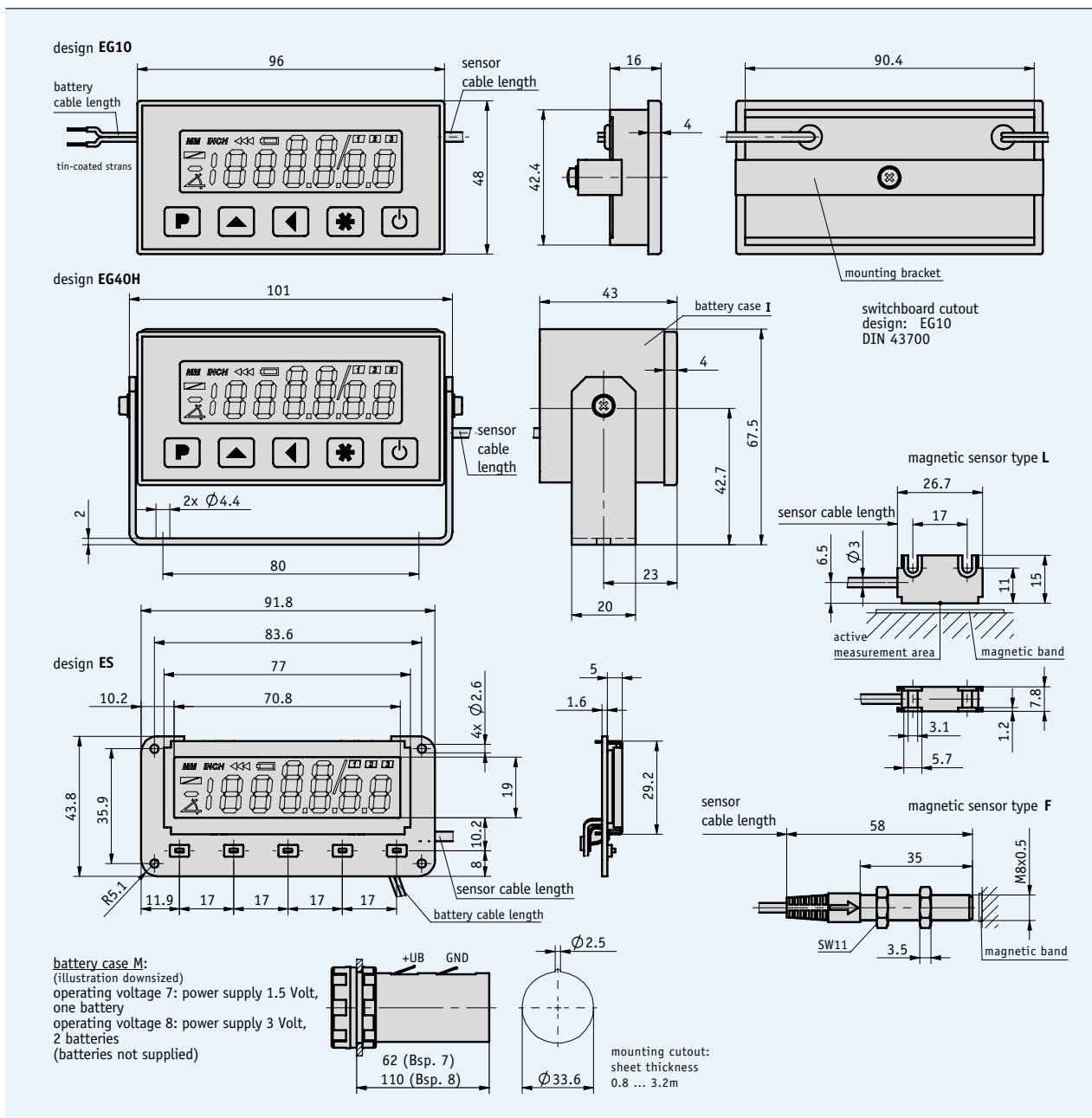

Mechanical data

Feature	Technical data	Additional information
System accuracy	±(0.1+ 0.01 x L) mm, L in mm	
Repeat accuracy	±1 digit	max. ±0.01 mm
Magnetic sensor	hard-wired	
Supply connection	strand led to the outside integrated battery compartment	with external battery holder
Display/display range	low-power LCD, approx. 12.5 mm high	decimal up to 10 µm, fraction-inch up to 1/16 Inch
Design	rectangle with elongated hole round design	
Housing	panel-mount housing, approx. 40 mm deep, installation kit	
Protection category	IP40 whole device, IP54 front side, IP67 sensor	
Operating temperature	0 ... +60 °C	
Storage temperature	-30 ...+80 °C	
Humidity	condensation inadmissible	
Travel speed	max. 5 m/s	

Electrical data

Feature	Technical data	Additional information
Operating voltage	3 V DC 1.5 V DC	
Current consumption	approx. 400 µA	with battery monitoring
Resolution	max. 10 µm	programmable
Interference protection class	3	according to IEC 801

Pin assignment

Signal	Cable color
GND	black
+UB	red

Order

Order table

Feature	Order data	Specifications	Additional information
Housing design	EG10	A	panel-mount housing, approx. 40 mm deep
	EG40H	A	panel-mount housing, approx. 40 mm deep
	ES		installation kit
Operating voltage	7	B	3 V DC
	8	B	1.5 V DC
			only with ES design ES
Sensor design	L	C	rectangular
	F	C	round
Sensor cable length	...	D	0.3 ... 2 m in steps of 0.1 m
Supply cable length	...	E	0.3 ... 2 m in steps of 0.1 m
Battery compartment	M	F	with
	O	F	without
	I		integrated
			only EG40H with operating voltage 7

Order code

MA503/1 - - - - - -

Scope of delivery: MA503/1, User information, Allen fastening screws M3 x 14 mm ISO 4762, lock washers M3 DIN 7980, strain relief for sensor cable, distance gage 0.8 mm

Additional information:

Short Description, Technical Details
Product Overview

Page 46 cont.
Page 4 cont.

Profile

- Max. display accuracy 10 µm or 1/8 inch
- Repeat accuracy 1 digit – max. ±0.01 mm
- Low-power LCD with decimal and fraction-inch function
- Max. sensor/band reading distance 2 mm
- Battery-buffered memory
- Works with receiver module RTX500



5.2

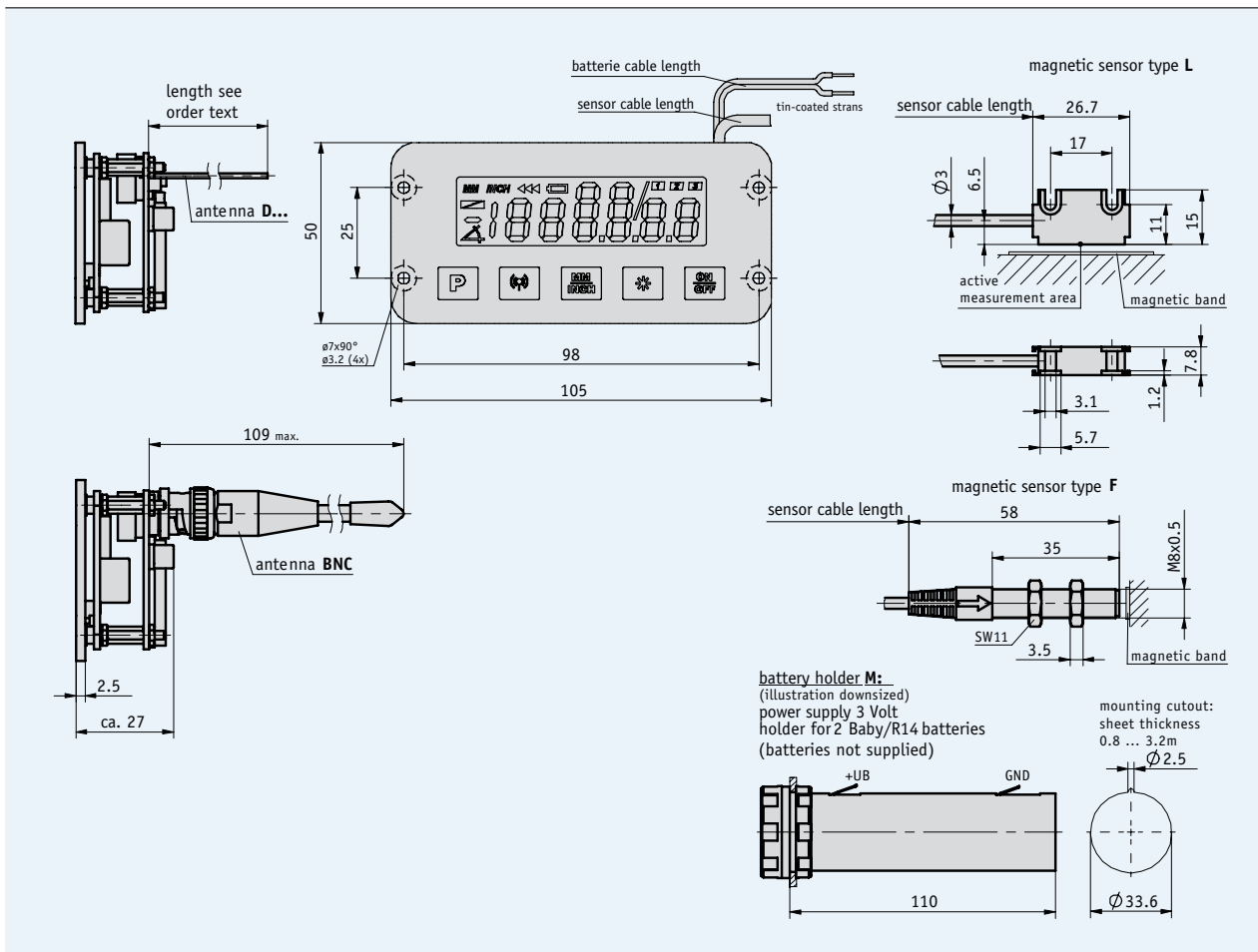

Mechanical data

Feature	Technical data	Additional information
System accuracy	±0.1 mm	
Repeat accuracy	±0.01 mm	
Magnetic sensor	hard-wired	
Supply connection	strand led to the outside	external battery holder
Display/display range	-999 999 ... 999 999	
V _{max} of sensor	5 m/s	with reading distance of 0.1–2 mm
Design	installation kit	
Protection category	IP40 (display) IP67 (sensor)	
Operating temperature	0 ... +60 °C	
Storage temperature	-20 ... +70 °C	
Humidity	condensation inadmissible	

Electrical data

Feature	Technical data	Additional information
Operating voltage	2 ... 3,5 V DC	
Current consumption	Display: max. 600 µA with 3 V DC send operation: 27 ... 55 mA with 3 V DC	
Interfaces/protocol	RS232/RS485	see RTX500 receive side
Resolution	max. 10 µm	

Pin assignment

Signal	Cable color
GND	black
+UB	red

Order

■ **Order table**

Feature	Order data	Specifications	Additional information
Sensor design	L	A	rectangle with elongated hole
	F		round design
Sensor cable length	...	B	0.3 ... 2 m in steps of 0.1 m
Battery cable length	...	C	0.2 ... 2 m in steps of 0.1 m
Operating mode	TX	D	send
	RX		receive
Software	S	E	bi-directional communication
	SW05		
Battery holder	M	F	with
	O		without
Antenna	BNC	G	wire length 82 mm
	D82		radio frequency 915
	D86		wire length 86 mm
	D120		wire length 120 mm
Radio frequency MHz	869	H	worldwide outside USA
	915		USA

■ **Order code**

MA503/WL- ES - A - B - C - D - E - SF-83606 - F - G - H

Scope of delivery: MA503WL, User information

Additional information:

Short Description, Technical Details
Product Overview

Page 46 cont.
Page 4 cont.

Profile

- Works with radio-based magnetic display MA503WL
- Mounting on top-hat rail or as an installation kit
- Pluggable BNC antenna
- 24 V DC supply
- RS232 or RS485 interface with ASCII-protocol

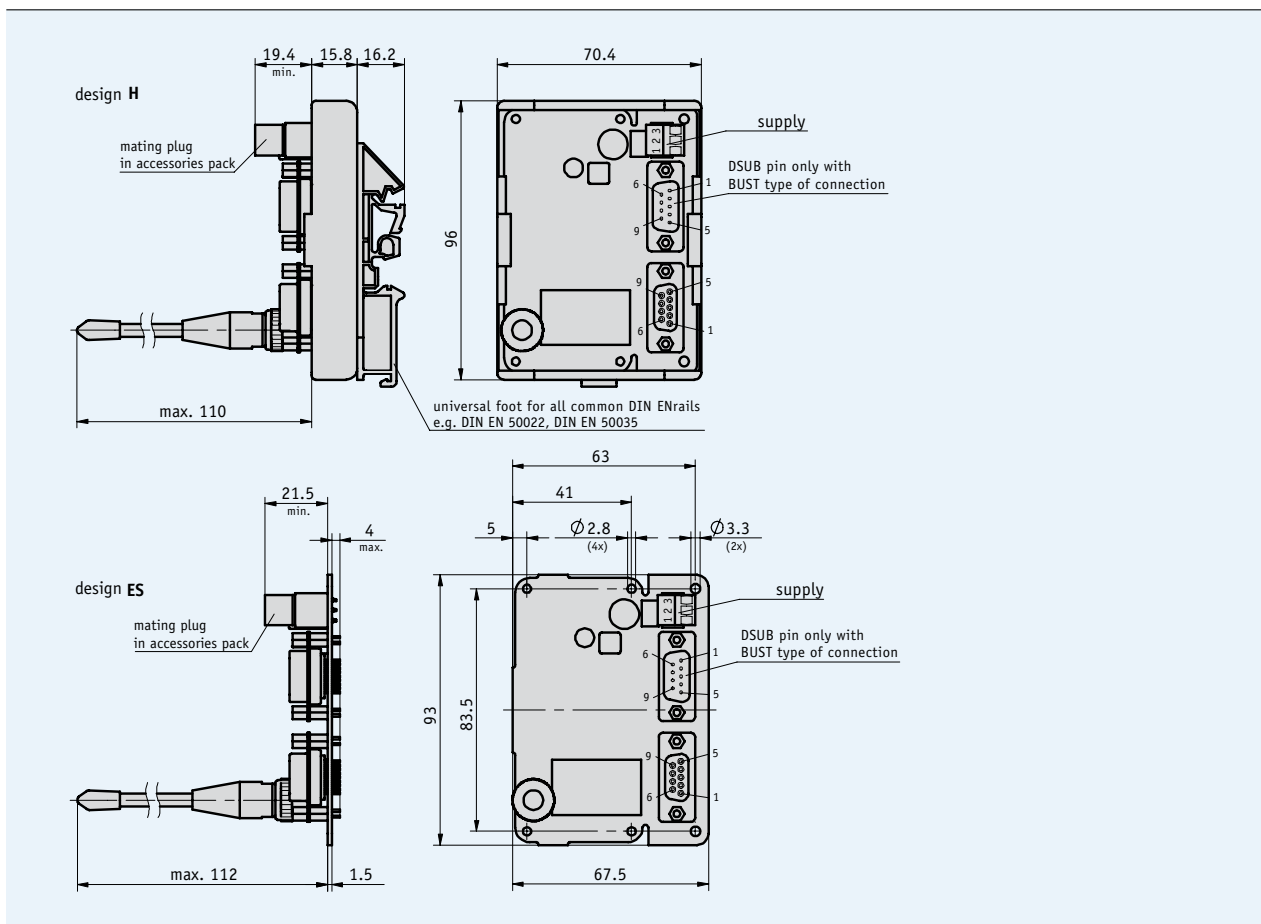

5.2

Mechanical data

Feature	Technical data	Additional information
Housing	Plastic	snap module for top-hat rail mounting
Electrical connection	3-pin screw-type terminal for supply	D-SUB 9-pin for signal output
Protection category	IP40	
Humidity of translation module	condensation inadmissible	
Operating temperature	0 ... +60 °C	
Storage temperature	-20 ... +70 °C	

Electrical data

Feature	Technical data	Additional information
Operating voltage	24 V DC ±20 %	
Power input	<1 VA	
Interfaces	RS232, RS485	
Receive sensitivity	-111 dbm	
Radio frequency	868 ... 870 MHz	
Interference protection class	3	according to IEC 801

Pin assignment

Supply

Signal	PIN
+UB	1
GND	2
PE	3

RS485, 9-pin DSUB

Signal	PIN
DÜB (D-)	1
N.C.	2, 3
DÜA (D+)	4
GND	5
N.C.	6-9

RS232, 9-pin DSUB

Signal	PIN
N.C.	1
TXD	2
RXD	3
N.C.	4
GND	5
N.C.	6-9

5.2

Order

Order table

Feature	Order data	Specifications	Additional information
Design	H	A	top-hat rail mounting
	ES		installation kit
Type of connection	BU	B	9-pin DSUB-bush
	BUST		2 x 9-pin DSUB-bush + pin
Operating mode	TX	C	send
	RX		receive
Interface	RS232	D	
	RS485		
Software	S	E	standard
	SW03		bi-directional communication
Antenna	BNC	F	
Radio frequency	869	G	USA
	915		

Order code

RTX500 - - - - - - -

A B C D E F G

Scope of delivery: RTX500, User information

Additional information:

Short Description, Technical Details
Product Overview

Page 46 cont.
Page 4 cont.

Profile

- Max. display accuracy of 10 μm
- Repeat accuracy 1 digit, max. $\pm 0.01\text{ mm}$
- Lowest-power LCD
- Up to 3 years of service life without battery change
- Metric or decimal-inch indication

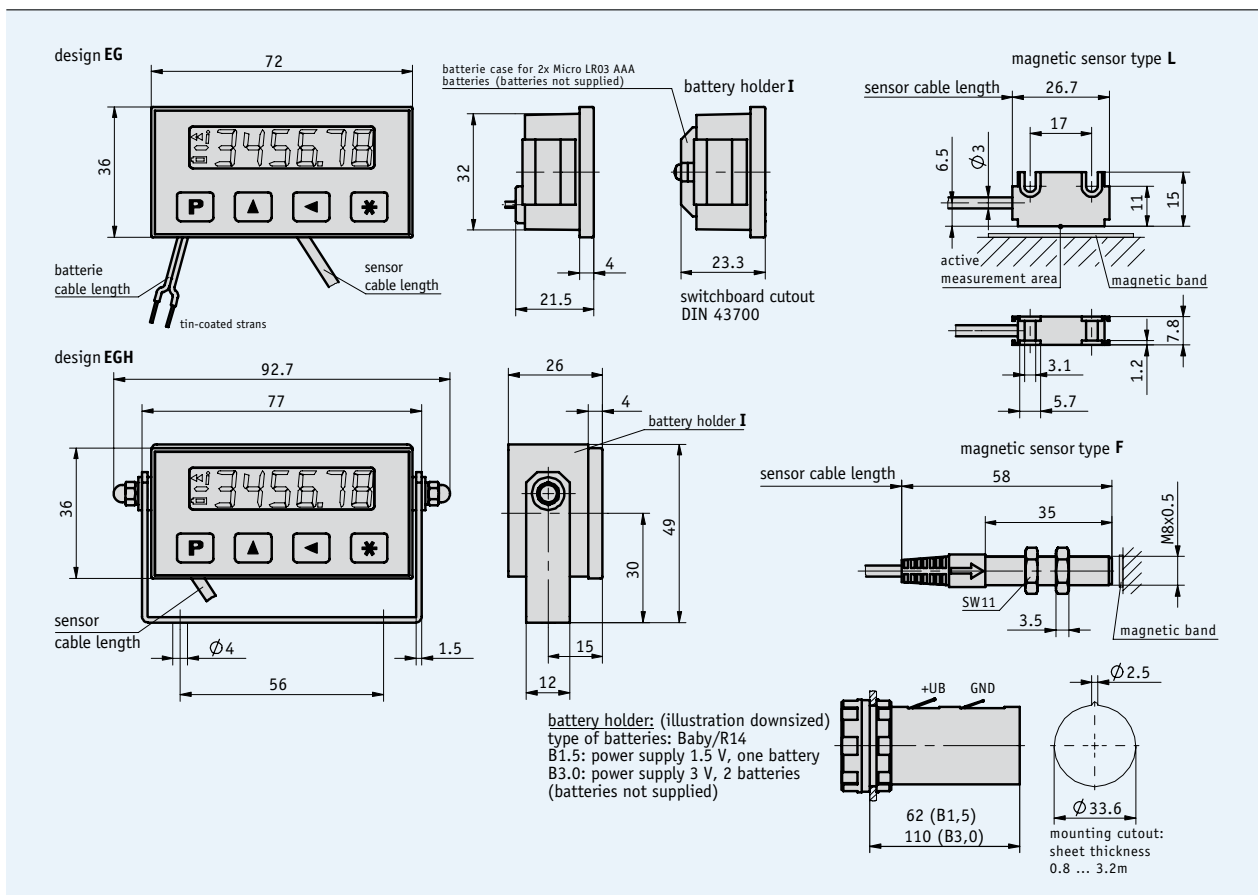

Mechanical data

Feature	Technical data	Additional information
System accuracy	$\pm(0.1 + 0.01 \times L)$, L in m	with magnetic band MB500 at $T_U = 20\text{ °C}$
Repeat accuracy	± 1 digit	max. ± 0.01 mm
Magnetic sensor	hard-wired	
Electrical connection	without connection strand	integrated battery holder external battery holder
Display/display range	6-digit LCD	-999 999 ... +999 999
Design	panel-mount housing panel-mount housing with shackle	
Housing	plastic (transparent)	
Protection category	IP40 whole device IP 54 front side IP67 sensor	
Operating temperature	0 ... +60 °C	
Storage temperature	-30 ... +80 °C	
Humidity	condensation inadmissible	
Travel speed	max. 5 m/s	

Electrical data

Feature	Technical data	Additional information
Operating voltage	1 ... 3.3 V DC	
Current consumption	max. 170 µA with 3 V DC max. 350 µA with 1.5 V DC	<50 µA standby <100 µA standby
Resolution	max. 10 µm	

Pin assignment

Signal	Cable color
GND	black
+UB	red

Order

Order table

Feature	Order data	Specifications	Additional information
Housing design	EG	A panel-mount housing	
	EGH	A panel-mount housing with shackle	
Sensor design	L	B rectangle with elongated hole	
	F	B round design	
Sensor cable length	...	C 0.3 ... 2 m in steps of 0.1 m	
Battery cable length	...	D 0.2 ... 2 m in steps of 0.1 m	
Electrical connection	0A	E without external connection	integrated battery holder
	L	E connection cables led through	external battery holder
Battery holder	I	F integrated	
	B1.5	F with external battery holder 1.5 V	only with electrical connection L
	B3.0	F with external battery holder 3 V	only with electrical connection L
	0	F without battery holder	only with electrical connection L

Order code



Scope of delivery: MA504 with sensor, User information, Allen fastening screws M3 x 14 mm ISO 4762, lock washers M3 DIN 7980, strain relief for sensor cable, distance gage 0.8 mm

Additional information:

Short Description, Technical Details
Product Overview

Page 46 cont.
Page 4 cont.

Profile

- Max. display accuracy 0.1 mm
- Repeat accuracy ± 1 digit
- Lowest-power LCD with integrated sensor
- Supply via integrated battery with up to 10 years of service life
- Programmable via programming tool PTM



5.2

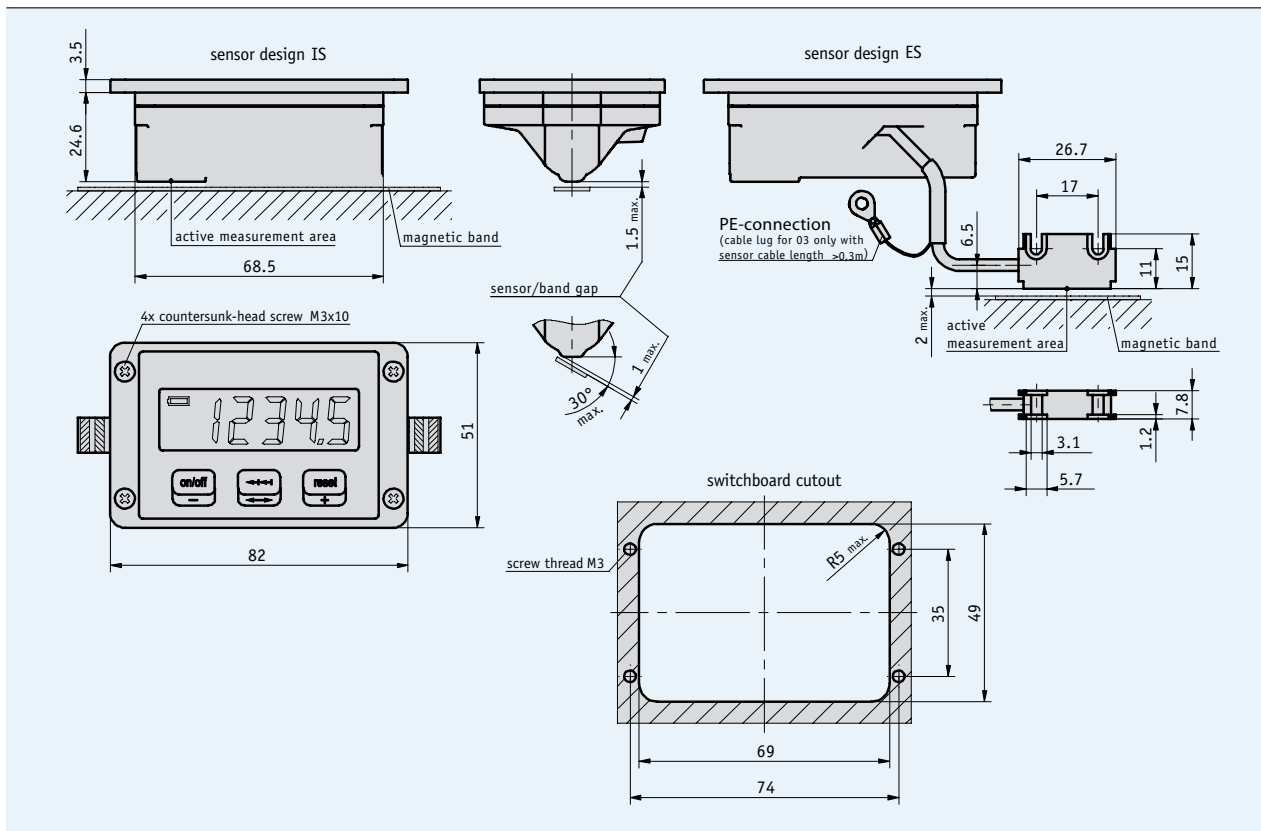

Mechanical data

Feature	Technical data	Additional information
System accuracy	± 0.1 mm	
Repeat accuracy	± 1 digit	
Magnetic sensor	hard-wired	
Display/display range	-99 999 ... +99 999	
Design	panel-mount housing	
Housing	zinc die-cast	
Protection category	IP20 whole device IP60 display side	
Operating temperature	0 ... +60 °C	
Storage temperature	-20 ... +70 °C	
Humidity	95 % rh	condensation inadmissible

Electrical data

Feature	Technical data	Additional information
Interfaces/protocol	interface for PTM (programming tool)	
Resolution	0.1, 1, 1.25, 2, 2.5, 5, 10 mm	
Parameter settings	non-volatily programmable	via external programming tool PTM

Order

■ **Order table**

Feature	Order data	Specifications	Additional information
Sensor design	IS	integrated sensor	
	ES	external sensor	
Sensor cable length	... B	0.1 ... 2 m in steps of 0.1 m	only with sensor design ES

■ **Order code**

MA508 - EG - A - L - B - SF-83083

Scope of delivery: MA508 with sensor, User information



Accessories:
 Programming device PTM Page 170

Additional information:
 Short Description, Technical Details Page 46 cont.
 Product Overview Page 4 cont.

Profile

- Max. display accuracy 10 μm
- Repeat accuracy ±1 digit (max. ±0.01 mm)
- Max. sensor/band reading distance 2 mm



5.2

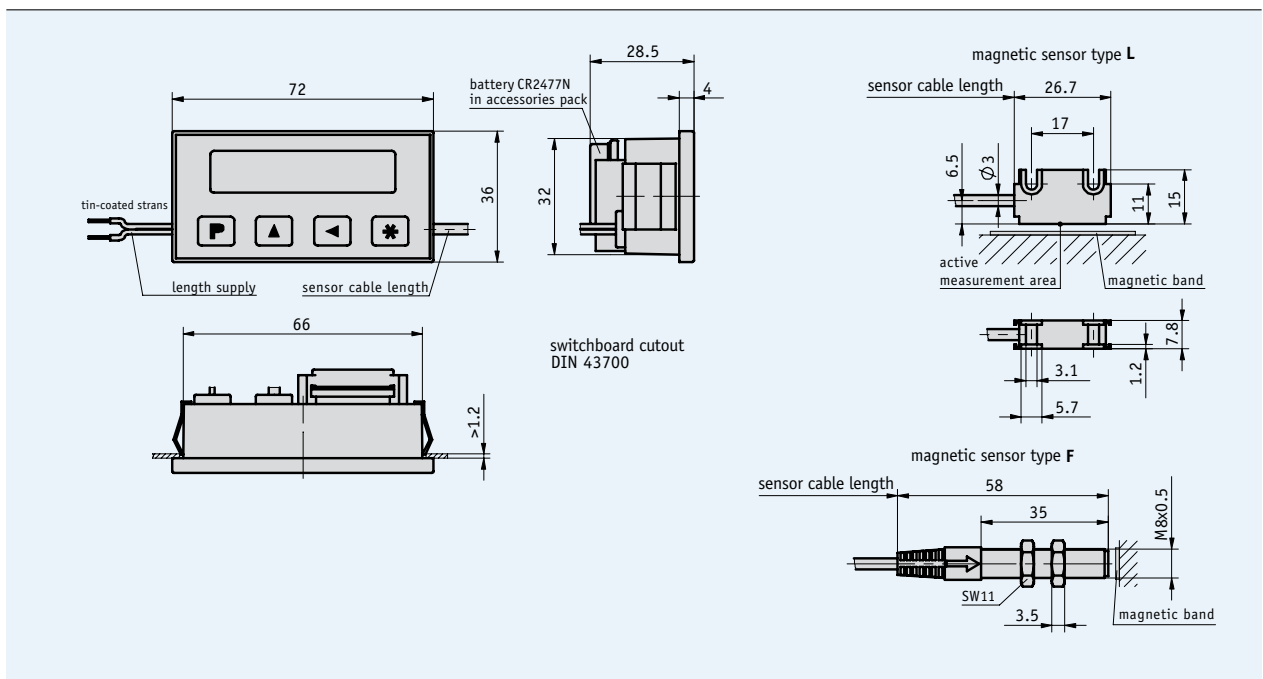

Mechanical data

Feature	Technical data	Additional information
System accuracy	±(0.1 + 0.01 × L) mm, L in m	at T _U = 20 °C
Repeat accuracy	±1 digit	max. ±0.01 mm
Magnetic sensor	hard-wired	
Electrical connection	cable	
Display/display range	-999 999 ... 999 999	
Design	panel-mount housing with retainer	
Housing	plastic transparent	
Protection category	IP40 whole device IP54 front side IP67 sensor	
Operating temperature	0 ... +60 °C	
Storage temperature	-30 ... +80 °C	
Humidity	condensation inadmissible	
Travel speed	max. 5 m/s	

Electrical data

Feature	Technical data	Additional information
Operating voltage	10 ... 30 V DC	at $T_U = 20\text{ °C}$
Current consumption	<8 mA with 24 V DC <25 µA with 3 V DC (backup operation)	
Resolution	10 µm	

Pin assignment

Signal	Cable color
GND	black
+UB	red

Order

Order table

Feature	Order data	Specifications	Additional information
Sensor design	L	rectangular	
	F	round	
Sensor cable length	...	0.1 ... 2 m in steps of 0.1 m	
Supply cable length	1.0	1 m	
	2.0	2 m	

Order code

MA564 - EG - A - B - C - S - SF-82597

Scope of delivery: MA564 with sensor, User information, Allen fastening screws M3 x 14 mm ISO 4762, lock washers M3 DIN 7980, strain relief for sensor cable, distance gage 0.8 mm, battery CR2477N

Additional information:

Short Description, Technical Details
Product Overview

Page 46 cont.
Page 4 cont.

Translation Module ASA510

Quasi-absolute, battery-buffered translation module

Profile

- Max. resolution 10 μm
- Repeat accuracy 1 increment, max. $\pm 0.01\text{ mm}$
- SSI or RS485 interface
- Scale MB500
- Compact, absolutely measuring unit with hard-wired sensor
- Max. measuring length $\pm 655\text{ m}$

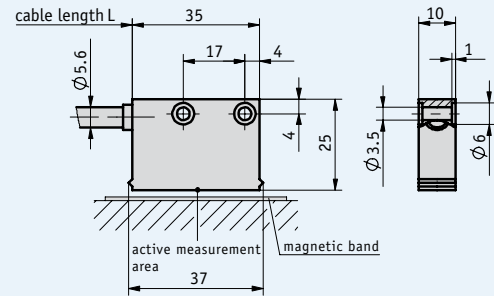
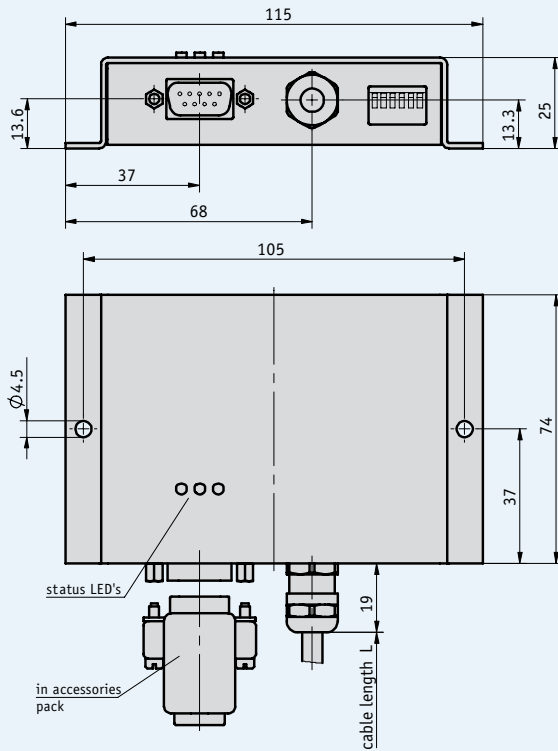

Mechanical data

Feature	Technical data	Additional information
System accuracy	(0.025 + 0.01 x L) mm, L in m	at T _U = 20 °C; (L= length per each meter started)
Repeat accuracy	±1 increment	max. ±0.01 mm
Sensor/band reading distance	max. 2 mm	over the whole measuring length
Measuring length	±655 000 mm	
Housing	sheet steel	electrogalvanized
Cable length of connection line	max. 6 m	acc. to RS422 specification
Sensor cable sheath	PUR oil-resistant	
Travel speed of magnetic sensor	max. 5 m/s	
Electrical connection	D-SUB 9-pin for supply and signal output	
Protection category	IP40 (translation module) IP67 (sensor)	according to DIN VDE 0470 according to DIN 40050
Humidity of translation module	max. 95 % rh	condensation inadmissible
Humidity of sensor	max. 100 % rh	condensation permitted
Operating temperature	0 ... +60 °C	
Storage temperature	-20 ... +70 °C	
Weight	approx. 400 g	

Electrical data

Feature	Technical data	Additional information
Operating voltage	24 V DC ±20 %	with reverse-polarity protection
Power input	<5 VA	
Resolution	10 µm	
Interfaces	SSI RS485 SIKONETZ-3 (bus-compatible)	switch-selectable SSI, RS485
Interference protection class	3	according to IEC 801
SSI clock rate	max. 1 MHz	

5.2

Order

Order table

Feature	Order data	Specifications	Additional information
Sensor cable length	...	A 1 ... 6 m in steps of 1 m	
Interface	SSI RS485	B according to RS422 A, 24 bit SIKONETZ-3, bus-compatible/SERVICE standard protocol	switch-selectable SSI/RS485

Order code

ASA510 - A - A - B

Scope of delivery: ASA510, User information,
D-SUB-bush 9-pin, grounding material

Additional information:

Short Description, Technical Details
Product Overview

Page 46 cont.
Page 4 cont.

cm 5.3

MSK2000

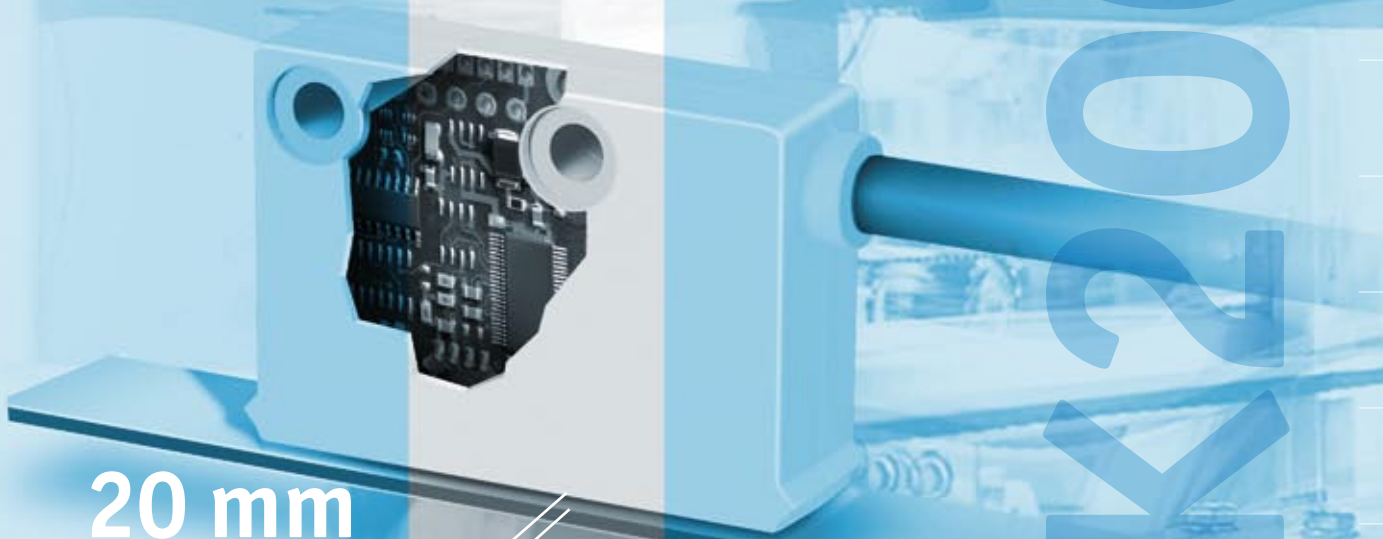

20 mm

5.0 MagLine Product Overview	3
5.1 MagLine Micro	12
5.2 MagLine Basic	44

5.3 | MagLine Macro

Short Description, Technical Details		112
Product Matrix		113
Products		
incremental	MB400	114
	MB2000	116
	MB4000	118
	MSK400/1	120
	MSK2000	123
	MSK4000	126
absolute	MBA1000	129
	MSA1000	131

5.4 MagLine Roto	134
5.5 Accessories	168
5.6 Appendix	182
5.7 Product index, Contact information	188

5.0

5.1

5.2

5.3

5.4

5.5

5.6

5.7

Introduction

Designed for very long paths, the system measures paths of 160 meters and more – as an incremental or absolute system as required. Digital signal outputs forward the measured values via the respective interfaces with a resolution and accuracy of up to 1 mm to displays or higher-level controllers. With its high level of reliability, also in very rough environments, the MagLine Macro is mainly used in the storage and conveying sectors.

- Incremental and absolute measuring systems
- Resolutions of up to 0.25 mm
- Reproducibility and absolute accuracy up to 1 mm

System access

MagLine Macro is suitable for incremental and absolute magnetic measurement. A direct product comparison is possible in the matrix opposite. Macro measurement systems comprise the individual components sensor and magnetic band. The available sensors support signal evaluation via digital outputs (square wave signal, incremental systems) or standardized, digital interfaces (SSI or RS485 absolute systems).

Free and flexible integration into new or existing systems is its main application. Corresponding individual components can be customized and therefore adapted optimally to existing measuring conditions. The values measured by the contactless sensors are generally processed further by follow-up electronic systems or controllers. We would be pleased to put our entire know-how at your disposal to help you design a robust and fail-safe measuring system for long paths. Feel free to contact us at any time.



Magnetic bands

Measuring length up to 160 m (absolute), theoretically infinite (incremental)
Accuracy class up to 1 mm

Sensors

For direct connection to downstream electronics (e.g., PLC)
Max. tolerance of reading distance to scale 20 mm
Incremental und absolute interfaces



5.3

The compact design of the magnetic band and sensor permits integration into almost any guide system.

MagLine Macro

Signal analysis via	Incremental systems		Absolute systems	
	Output, digital		Interface	
System accuracy class (mm)	±1	±1	±2	±2.5
Maximum repeat accuracy (mm)	±1	±0.25	±0.5	±1
Maximum measurement length/magnetic display	infinite	infinite	infinite	163 m
Maximum reading distance (mm)	4.0	10.0	20.0	3.5

Resolution max. in mm	Supply voltage	Output/ interface	Magnetic sensor	Page				
1	24 V DC	PP	MSK400/1	120				
0.25	24 V DC 5 V DC	PP, LD	MSK2000	123				
0.25	24 V DC 5 V DC	PP, LD, TTL	MSK4000	126				
1	24 V DC	SSI, RS485	MSA1000	131				

Width in mm	Available length max. in m/piece	Magnetic band						
5 or 10	90.0	MB400	114					
10 or 20	90.0	MB2000	116					
20	90.0	MB4000	118					
10	163.0	MBA1000	129					

5.3

Magnetic Band MB400

Incrementally coded scale, 4 mm pole length

Profile

- Easy adhesive mounting, self-assembly possible
- Pole length 4 mm
- System accuracy up to 1 mm

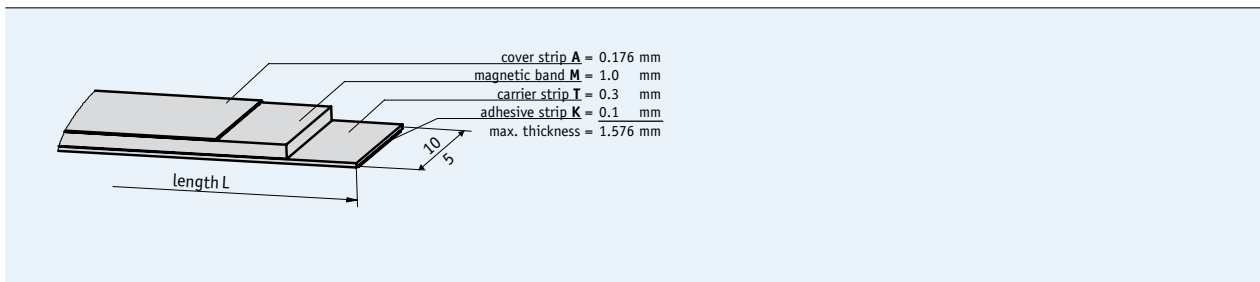

5.3

Mechanical data

Feature	Technical data	Additional information
Pole length	4 mm	
Measuring length	infinite	
Band width	10 mm 5 mm	
Thickness	1.4 mm	without cover strip
Temperature coefficient	$(11 \pm 1) \times 10^{-6}/K$ $(16 \pm 1) \times 10^{-6}/K$	spring steel stainless steel
Operating temperature	-20 ... +70 °C	
Storage temperature	-40 ... +70 °C	
Humidity	100 % rh	condensation permitted
Mounting type	glued joint	pre-assembled double-sided adhesive strip
Cover strip material	stainless steel	

Order

The necessary band length is calculated as follows:
Measured path + sensor length "S" + (2 x lead-in and lead-out "B"). Sensor length "S" refer to the drawing of the employed sensor, lead-in and lead-out "B" = 50 mm.

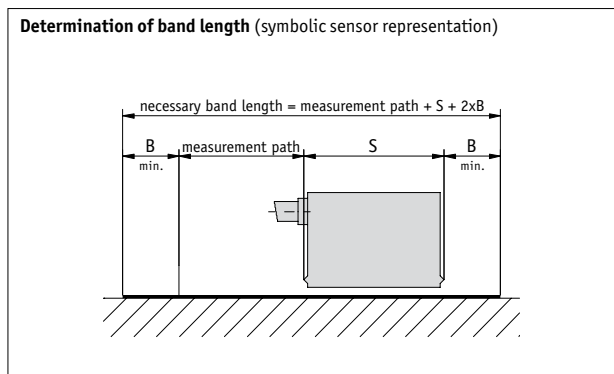

■ **Order table**

Feature	Order data	Specifications	Additional information
Width	10	A band width in mm	
	5	B band width in mm	
Carrier strip material	St	B spring steel	
	VA	stainless steel	
Length of magnetic band	...	C 0.1 ... 90 m, in steps of 0.1 m	Order information, see "Determination of band length"
Adhesive carrier strip	TM	D with	
	TO	without	
Cover strip	AM	E with	
	AO	without	

■ **Order code**

MB400 - - - - -

Scope of delivery: MB400, User information

Accessories:

- Profile rail PS Page 178
- Protective strip SB Page 179
- Cover rail PS1 Page 177

Additional information:

- Short Description, Technical Details Page 112 cont.
- Product Overview Page 4 cont.

Magnetic Band MB2000

Incrementally coded scale, pole length 20 mm

Profile

- Easy adhesive mounting, self-assembly possible
- Pole length 20 mm
- System accuracy up to 1 mm

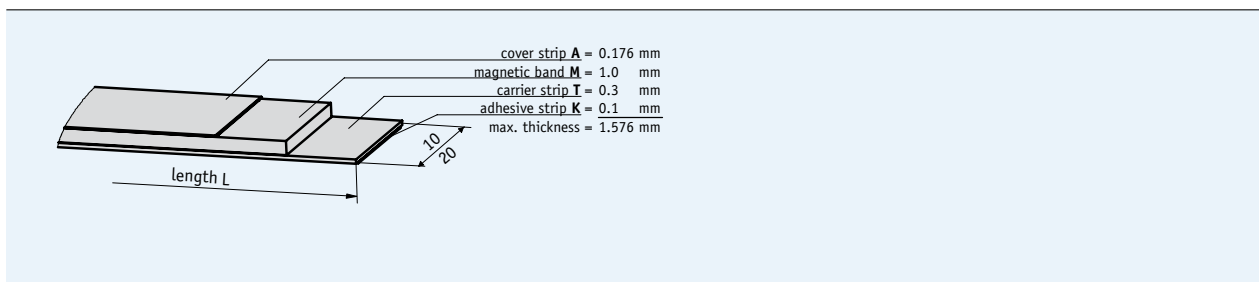

5.3

Mechanical data

Feature	Technical data	Additional information
Pole length	20 mm	
Measuring length	infinite	
Band width	10 mm 20 mm	
Thickness	1.4 mm	without cover strip
Temperature coefficient	$(11 \pm 1) \times 10^{-6}/K$ $(16 \pm 1) \times 10^{-6}/K$	spring steel stainless steel
Operating temperature	-20 ... +70 °C	
Storage temperature	-40 ... +70 °C	
Humidity	100 % rh	condensation permitted
Mounting type	glued joint	pre-assembled double-sided adhesive strip
Cover strip material	stainless steel	

Order

The necessary band length is calculated as follows:
Measured path + sensor length "S" + (2 x lead-in and lead-out "B"). Sensor length "S" refer to the drawing of the employed sensor, lead-in and lead-out "B" = 50 mm.

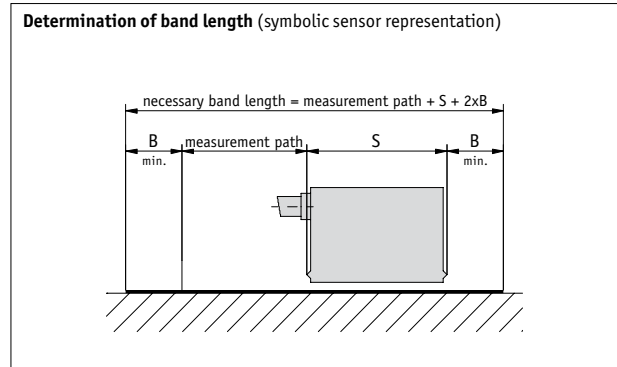

Order table

Feature	Order data	Specifications	Additional information
Width	10	band width in mm	
	20	band width in mm	
Carrier strip material	St	spring steel	
	VA	stainless steel	
	TBO	without steel carrier strip	
Length of magnetic band	...	0.1 ... 90 m, in steps of 0.1 m	Order information, see "Determination of band length"
Adhesive carrier strip	TM	with	only possible with carrier strip material "St" or "VA"
	TO	without	
Cover strip	AM	with	
	AO	without	

Order code

MB2000 - - - - -

Scope of delivery: MB2000, User information

Accessories:

Profile rail PS (only with 10 mm band width) Page 178
 Protective strip SB (only with 10 mm band width) Page 179
 Cover rail PS1 (only with 10 mm band width) Page 177

Additional information:

Short Description, Technical Details Page 112 cont.
 Product Overview Page 4 cont.

Magnetic Band MB4000

Incrementally coded scale, pole length 40 mm

Profile

- Easy adhesive mounting, self-assembly possible
- Without carrier strip
- Pole length 40 mm
- System accuracy up to 2 mm

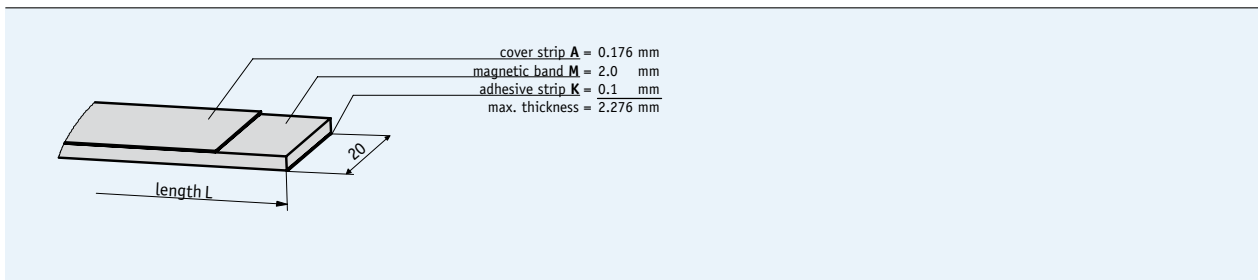

5.3

Mechanical data

Feature	Technical data	Additional information
Pole length	40 mm	
Measuring length	infinite	
Band width	20 mm	
Thickness	2 mm	without cover strip or adhesive strip
Operating temperature	-20 ... +70 °C	
Storage temperature	-40 ... +70 °C	
Humidity	100 % rh	condensation permitted
Mounting type	glued joint	pre-assembled double-sided adhesive strip
Cover strip material	stainless steel	

Order

The necessary band length is calculated as follows:
Measured path + sensor length "S" + (2 x lead-in and lead-out "B"). Sensor length "S" refer to the drawing of the employed sensor, lead-in and lead-out "B" = 100 mm.

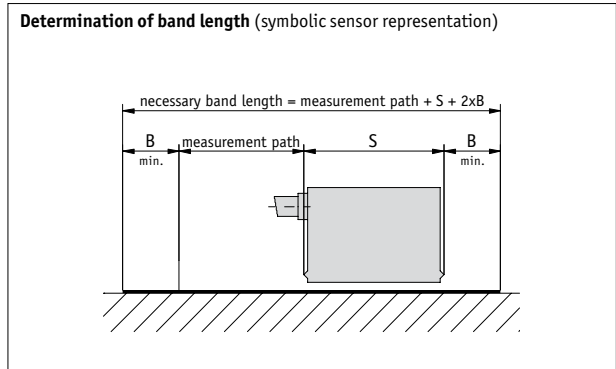

■ **Order table**

Feature	Order data	Specifications	Additional information
Length of magnetic band	... A	0.1 ... 90 m, in steps of 0.1 m	Order information, see "Determination of band length"
Adhesive carrier strip	TM	with adhesive strip	
	TO	without adhesive strip	
Cover strip	AO	without	
	AM	with	

■ **Order code**

MB4000 - 20 - A - B - C

Scope of delivery: MB4000, User information



Additional information:

Short Description, Technical Details
Product Overview

Page 112 cont.
Page 4 cont.

Profile

- Max. resolution 1 mm
- Repeat accuracy ±1 mm
- Max. sensor/band reading distance 4 mm

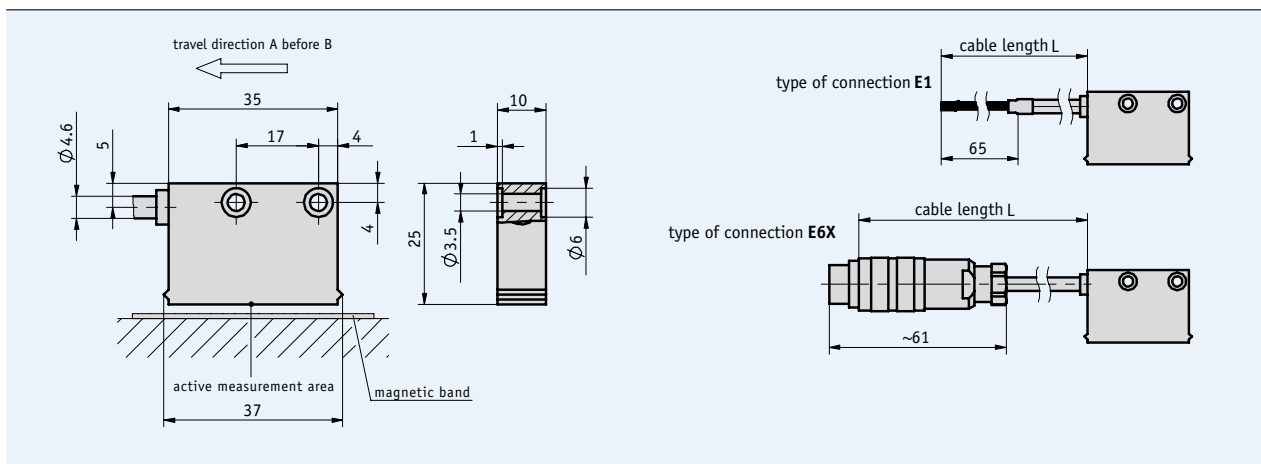

Mechanical data

Feature	Technical data	Additional information
Scale embodiment	MB400	
System accuracy	$\pm(1 + 0.03 \times L)$ mm	L = magnetic band length in m (at 20 °C)
Repeat accuracy	±1 mm	
Sensor/band reading distance	max. 4mm	
Travel speed	<10 m/s	
Housing	plastic, white	
Sensor cable	PUR, oil-resistant	
Operating temperature	-10 ... +70 °C	
Storage temperature	-30 ... +80 °C	
Humidity	100 % rh	condensation permitted
Protection category	IP67	
Vibration resistance	10 g/50 Hz	
Max. measuring length	infinite	

Electrical data

Feature	Technical data	Additional information
Operating voltage	24 V DC \pm 20 %	reverse-polarity protection on UB
Current consumption	<20 mA no load	
Type of connection	flying leads round connector	
Output circuit	PP	
Output signals	A, B	90° phase-shifted
Resolution	1 mm	with quadrature evaluation
Interference protection class	3	according to IEC 801
Real-time requirement	real-time signal processing	
Signal level high	UB -2.5 V	
Signal level low	<0.8 V	

Signal forms

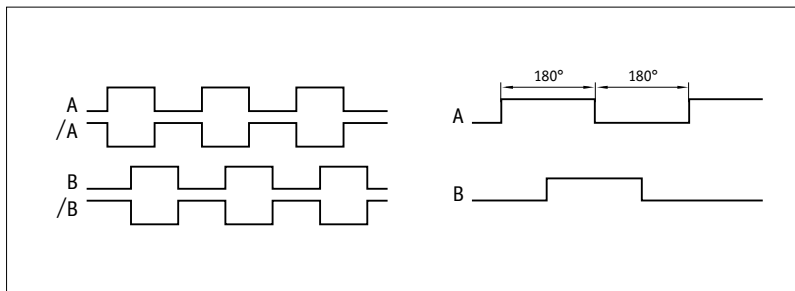

Pin assignment

non-inverted

Signal	E1	E6X
GND	black	1
A	red	2
B	orange	3
+UB	brown	5
Screen	white	
N.C.		4, 6, 7

Mounting instruction

Sensor/band reading distance A	max. 4 mm
Lateral offset B	max. \pm 2 mm

Sensor/band reading distance (symbolic sensor representation)

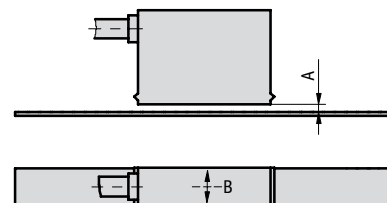

Order

Order table

Feature	Order data	Specifications	Additional information
Type of connection	E1	flying leads, 2 m cable	
	E6X	round connector without mating connectors cable extensions on request	
Cable length L	...	1 ... 20 m, in steps of 1 m	

Order code

MSK400/1 - -

A

B

5.3

Scope of delivery: MSK400/1, User information, Allen fastening screws M3 x 14 mm ISO 4762, strain relief for sensor cable, distance gage

Additional information:

Short Description, Technical Details
Product Overview

Page 112 cont.
Page 4 cont.

Profile

- Linear resolution 0.25 mm
- Repeat accuracy ± 1 increment, max. ± 0.25 mm
- Operating voltage 5 or 24 V
- Max. sensor/band reading distance 10 mm

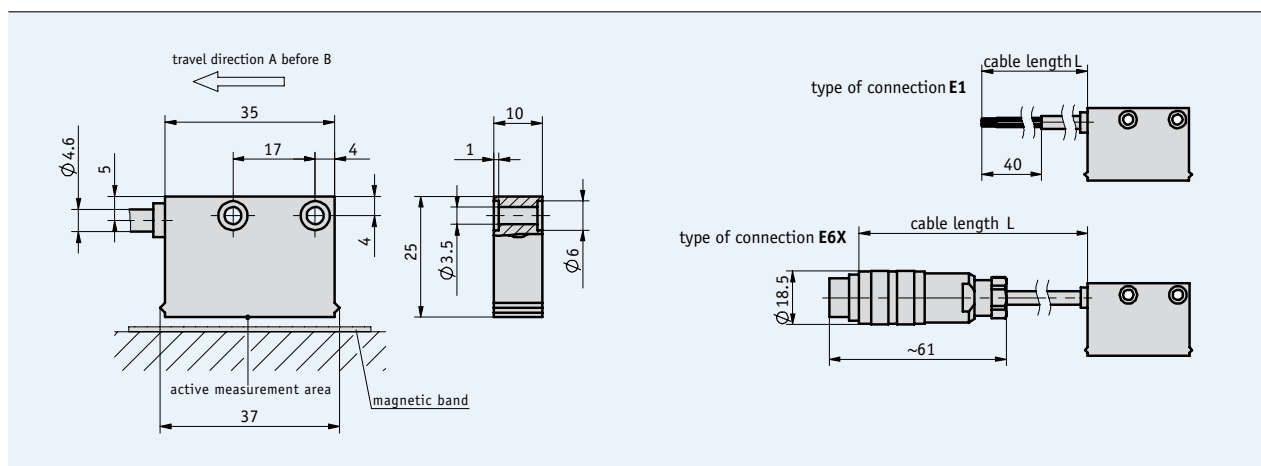

5.3

Mechanical data

Feature	Technical data	Additional information
Scale embodiment	MB2000	
System accuracy	$\pm (1 + 0.03 \times L)$ mm	L = magnetic band length in m (at 20 °C)
Repeat accuracy	± 1 increment	max. ± 0.25 mm
Sensor/band reading distance	max. 10 mm	
Travel speed	<10 m/s	
Housing	plastic, light-green	
Sensor cable	PUR, oil-resistant	drag chain-compatible
Operating temperature	-10 ... +70 °C	
Storage temperature	-30 ... +80 °C	
Humidity	100 % rh	condensation permitted
Protection category	IP67	according to DIN 40050 (Housing)
Vibration resistance	10 g/50 Hz	
Max. measuring length	infinite	

Electrical data

Feature	Technical data	Additional information
Operating voltage	24 V DC \pm 20 % 5 V DC \pm 5 %	reverse-polarity protection on UB no reverse-polarity protection on UB
Current consumption	<50 mA (PP), <25 mA (LD)	without load
Type of connection	flying leads round connector	
Output circuit	PP LD	
Output signals	A, B, option: /A, /B, I, /I	90° phase-shifted
Length of reference signal	1 increment	
Resolution	0.25, 1 mm	
Interference protection class	3	according to IEC 801
Real-time requirement	real-time signal processing	
Signal level high	UB – 2.5 V PP	LD according to RS422 specific
Signal level low	<0.8 V PP	LD according to RS422 specific

Signal forms

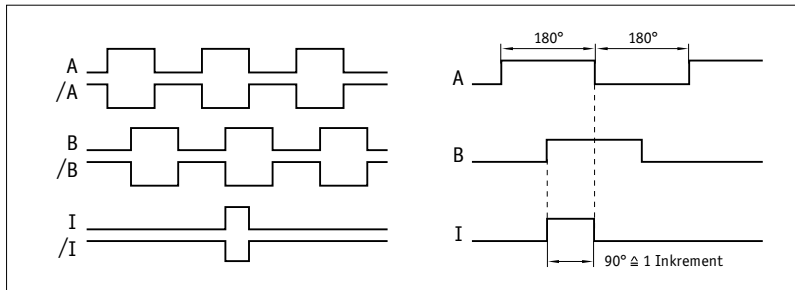

! The logical condition of signals A and B is not defined in reference to the index signal I or the reference signal R. It can deviate from the signal form.

Pin assignment

non-inverted

Signal	E1	E6X
A	red	3
B	orange	4
+UB	brown	2
GND	black	1
N.C.		5,6,7

inverted

Signal	E1	E6X
A	red	1
B	orange	2
+UB	brown	4
GND	black	5
A/	yellow	6
B/	green	7
N.C.		3

inverted with reference signal

Signal	E1	E6X
A	red	1
B	orange	2
I	blue	3
+UB	brown	4
GND	black	5
A/	yellow	6
B/	green	7
I/	violet	8

Mounting instruction

Sensor/band reading distance A	max. 10 mm
Lateral offset B	max. ±2 mm (10 mm band) max. ±5 mm (20 mm band)

Sensor/band reading distance (symbolic sensor representation)

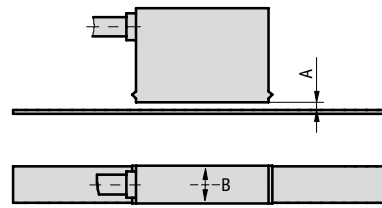

Order

Order table

Feature	Order data	Specifications	Additional information
Operating voltage	4	24 V DC ±20 %	reverse-polarity protection
	5	5 V DC ±5 %	no reverse-polarity protection
Type of connection	E1	flying leads, 2 m cable	
	E6X	round connector without mating connectors	
		cable extensions on request	
Cable length L	...	1 ... 20 m, in steps of 1 m	
Output circuit	PP	push-pull	
	LD	line driver	
Output signal	NI	non-inverted	
	I	inverted	
Reference signal	0	without	
	I	index periodic	
Resolution	...	0.25, 1	

Order code

MSK2000 - - - - - - -

Scope of delivery: MSK2000, User information, Allen fastening screws M3 x 14 mm ISO 4762, lock washers M3 DIN 7980, strain relief for sensor cable

Additional information:

Short Description, Technical Details
Product Overview

Page 112 cont.
Page 4 cont.

Profile

- Max. resolution of 0.25 mm
- Repeat accuracy ± 2 increments (max. ± 0.5 mm)
- Insensitive to dust, shavings, humidity, etc.
- Max. sensor/band reading distance 20 mm

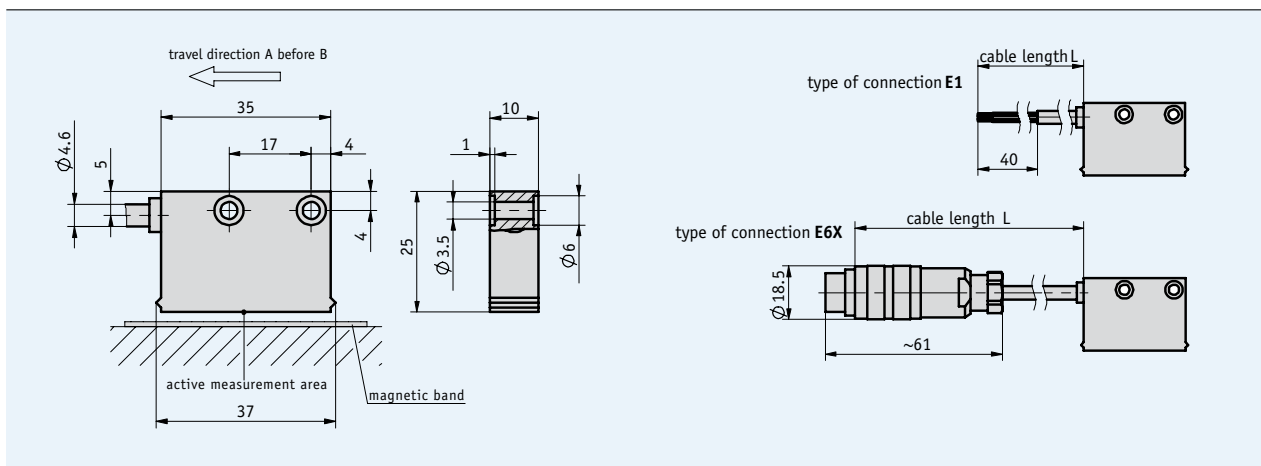

Mechanical data

Feature	Technical data	Additional information
Scale embodiment	MB4000	
System accuracy	± 2 mm, with nominal distance of 15 mm	length-dependent error depends on the mounting situation
Repeat accuracy	2 increments	max. ± 0.5 mm
Sensor/band reading distance	max. 20 mm, min. 5 mm	
Travel speed	<15 m/s	
Housing	plastic ABS, gray	
Sensor cable	PUR, oil-resistant	drag chain-compatible
Operating temperature	-10 ... +70 °C	
Storage temperature	-30 ... +80 °C	
Humidity	100 % rh	condensation permitted
Protection category	IP67	
Vibration resistance	10 g/50 Hz	
Max. measuring length	infinite	

Electrical data

Feature	Technical data	Additional information
Operating voltage	24 V DC \pm 20 % 5 V DC \pm 5 %	reverse-polarity protection on UB no reverse-polarity protection on UB
Current consumption	<50 mA (PP) <25 mA (LD)	no load
Type of connection	flying leads, round connector	
Output circuit	PP, LD, TTL	
Output signals	A, B, option: /A, /B, I, /I	90° phase-shifted
Length of reference signal	1 increment	
Resolution	0.25, 0.5, 1, 2 mm	
Interference protection class	3	IEC-61000-6-2
Real-time requirement	real-time signal processing	
Signal level high	UB – 2.5 V PP	LD according to RS422 specific, TTL > 2.4 V
Signal level low	<0.8 V	LD according to RS422 specific, TTL < 0.4 V

Signal forms

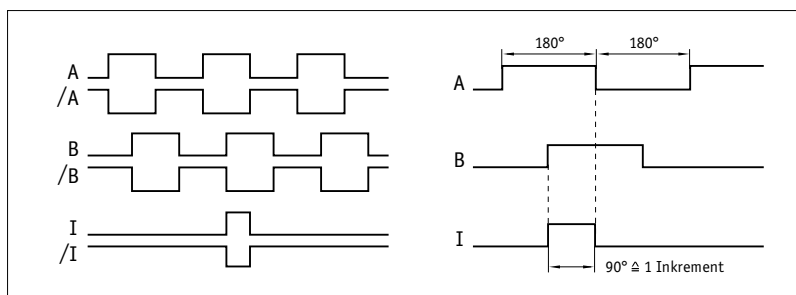

! The logical condition of signals A and B is not defined in reference to the index signal I or the reference signal R. It can deviate from the signal form.

Pin assignment

non-inverted

Signal	E1	E6X
A	red	3
B	orange	4
+UB	brown	2
GND	black	1
N.C.		5,6,7

inverted

Signal	E1	E6X
A	red	1
B	orange	2
+UB	brown	4
GND	black	5
A/	yellow	6
B/	green	7
N.C.		3

inverted with reference signal

Signal	E1	E6X
A	red	1
B	orange	2
I	blue	3
+UB	brown	4
GND	black	5
A/	yellow	6
B/	green	7
I/	violet	8

Mounting instruction

Sensor/band reading distance A	5 ... 20 mm
Lateral offset B	max. ±5 mm

Sensor/band reading distance (symbolic sensor representation)

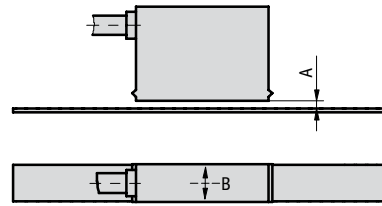

Order

■ **Order table**

Feature	Order data	Specifications	Additional information
Operating voltage	4	10 ... 30 V DC	reverse-polarity protection
	5	5 V DC ±5 %	no reverse-polarity protection
Type of connection	E1	flying leads	
	E6X	round connector without mating connectors	
		cable extensions on request	
Cable length L	...	1 ... 20 m, in steps of 1 m	
Output circuit	PP	push-pull	
	LD	line driver (RS422)	
	TTL		only possible with non-inverted signals
Output signal	NI	non-inverted	
	I	inverted	
Reference signal	0	without	
	I	index periodic	only possible with inverted signals
Resolution	...	0.25, 0.5, 1, 2	

■ **Order code**



Scope of delivery: MSK4000, User information



Additional information:

Short Description, Technical Details
Product Overview

Page 112 cont.
Page 4 cont.

Profile

- Easy adhesive mounting
- Easy self-assembly possible

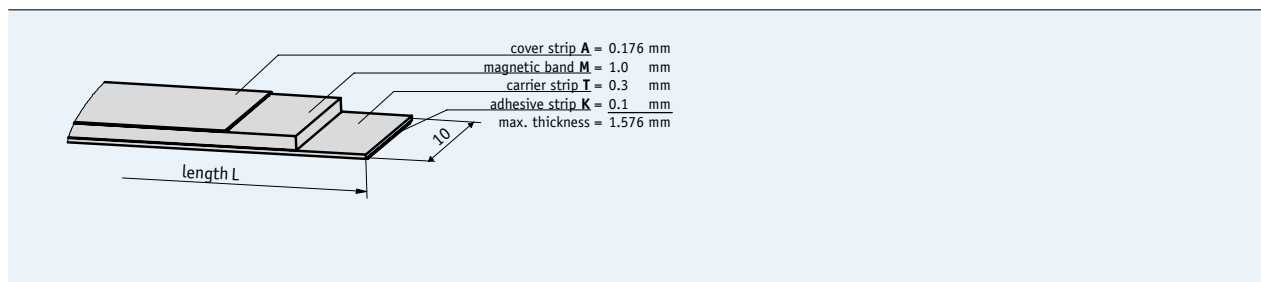

5.3

Mechanical data

Feature	Technical data	Additional information
Measuring length	163 m	
Band width	10 mm	
Thickness	1.4 mm	without cover strip
Temperature coefficient	(11±1) x 10 ⁻⁶ /K, spring steel (16±1) x 10 ⁻⁶ /K, stainless steel	
Operating temperature	-20 ... +70 °C	
Storage temperature	-40 ... +70 °C	
Humidity	100 % rh	condensation permitted
Mounting type	glued joint	pre-assembled double-sided adhesive strip
Cover strip material	stainless steel	

Order

The necessary band length is calculated as follows:
Measured path + sensor length "S" + (2 x lead-in and lead-out "B"). Sensor length "S" refer to the drawing of the employed sensor, lead-in and lead-out "B" = 5 mm.

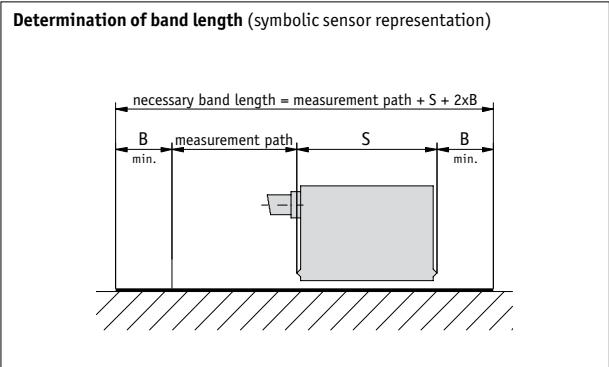

■ **Order table**

Feature	Order data	Specifications	Additional information
Length of magnetic band	... A	1 ... 163 m, in steps of 0.1 m	Order information, see "Determination of band length"
Carrier strip material	St	spring steel	
	VA	stainless steel	
Adhesive carrier strip	TM	with	
	TO	without	
Cover strip	AM	with	
	AO	without	

5.3

■ **Order code**

MBA1000 - - - - -

Scope of delivery: MBA1000, User information

➔ **Accessories:**

- Profile rail PS Page 178
- Protective strip SB Page 179
- Cover rail PS1 Page 177

Additional information:

- Short Description, Technical Details Page 112 cont.
- Product Overview Page 4 cont.

Profile

- Resolution of 1 mm
- Repeat accuracy ± 1 mm
- SSI or RS485 interfaces
- Max. sensor/band reading distance of 3.5 mm

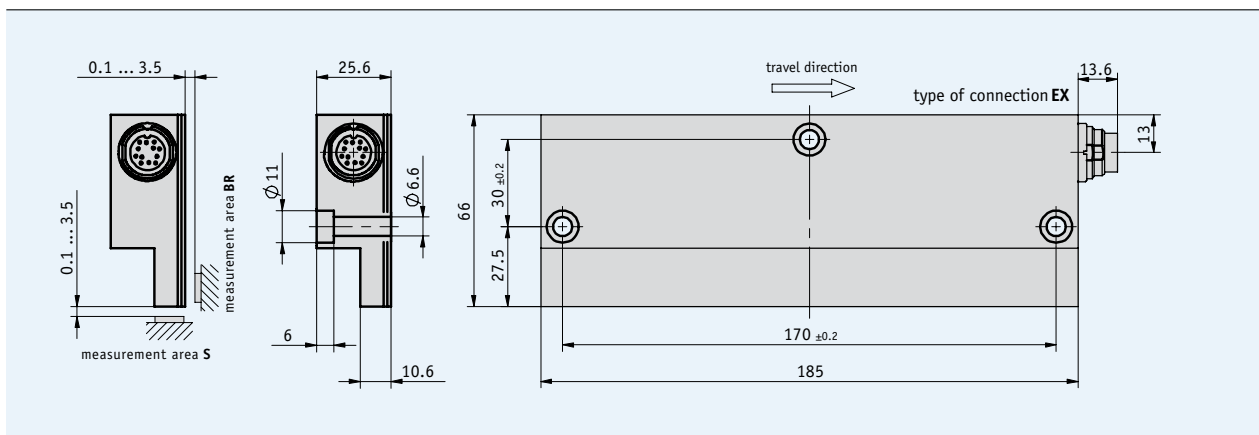

5.3

Mechanical data

Feature	Technical data	Additional information
Scale embodiment	MBA1000	
System accuracy	$\pm(2.5 + 0.03 \times L)$ mm, L in m	
Repeat accuracy	± 1 mm	
Sensor/band reading distance	$0.1 \dots 3.5$ mm	
Travel speed	5 m/s	real-time behavior up to 0.5 m/s
Housing	aluminum	
Operating temperature	$-20 \dots +55$ °C	
Storage temperature	$-20 \dots +85$ °C	
Humidity	100 % rh	condensation only permissible with completely encapsulated version
Protection category	IP65	
Vibration resistance	10 g/50 Hz	
Max. measuring length	≤ 163 m	

Electrical data

Feature	Technical data	Additional information
Operating voltage	24 V DC \pm 20 %	reverse-polarity protection on UB
Current consumption	<500 mA	
Power input	<10 VA	
Type of connection	without connector	
Interfaces	SSI or RS485	
Resolution	1 mm	
Interference protection class	3	according to DIN EN 50081-2 and DIN EN 50082-2
Real-time requirement	up to $v = 0.5$ m/s	
Baud rate	at 200 m max. SSI baud rate 125 kHz (10 x 0.25 mm)	

Pin assignment

Signal	EX
SSI data-	A
SSI data+	B
SSI clock-	C
SSI clock+	D
+24 V DC	E
RS485 GND	F
RS485 DÜA	G
RS485 DÜB	H
GND	J
GND	K
Configuration	L
N.C.	M

5.3

Mounting instruction

When installing the sensor and magnetic band, always ensure that both system components are correctly aligned. The arrows marked on the band and sensor must point in the same direction during installation.

Sensor/band reading distance A	max. 3.5 mm
Lateral offset B	max. \pm 1.5 mm

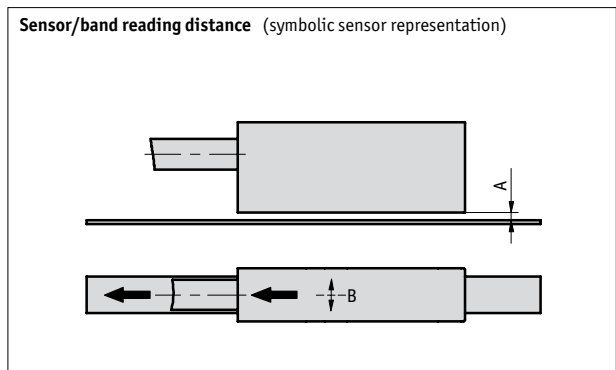

Order

Order note

This sensor is sold in Switzerland and Austria under the product name "AMSA1000".

Order table

Feature	Order data	Specifications	Additional information
Measurement area	S	narrow side	
	BR	wide side	
Electronics unit encapsulated	NV	not encapsulated	
	EV	electronics unit completely encapsulated	for outdoor applications

Order code

MSA1000 - - EX - OK -

Scope of delivery: MSA1000, User information

Additional information:

Short Description, Technical Details
Product Overview

Page 112 cont.
Page 4 cont.

rpn



5.4

MSK5000

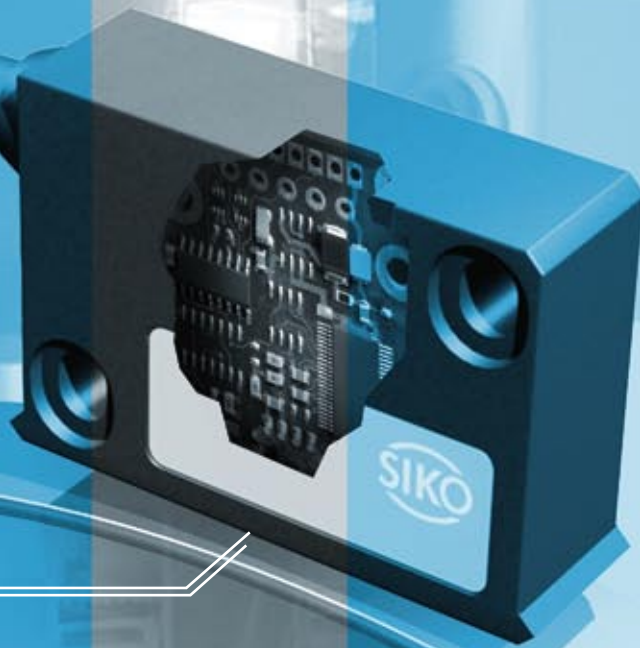

2 mm

5.0 MagLine Product Overview	3
5.1 MagLine Micro	12
5.2 MagLine Basic	44
5.3 MagLine Macro	110

5.4 | MagLine Roto

Short Description, Technical Details	136
Product Matrix	137
Products	
MR200	138
MR320	140
MR500	142
MRI01	144
MBR100	146
MBR200	148
MBR320	150
MBR500	152
LE100/1	154
MSK210	157
MSK320	160
MSK5000	163

5.5 Accessories	168
5.6 Appendix	182
5.7 Product index, Contact information	188

5.0

5.1

5.2

5.3

5.4

5.5

5.6

5.7

Introduction

With all the advantages of magnetic, contactless scanning, MagLine Roto is designed for direct angle and speed measurement. Special sensors scan the incremental graduation of magnetic rings and supply a resolution of up to 200 000 pulses per minute.

Typical applications of the system are speed measurement on drive units or angle measurement, for example on rotary tables. The compact design permits integration either directly or next to the control or machining process.

- Resolutions up to 0.0018°
- System accuracy ± 0.1°
- Rotary encoder system with protection category IP67

Introduction to the rotary system

MagLine Roto is an incremental measuring system. For this reason a wide range of magnetic band and ring diameters are possible. In a system with a set referencing point (ordering option) re-referencing is performed after each full rotation (360°) due to the rotary magnetic measurement, as the reference point is automatically traversed and the system therefore starts with an additional, origin-related measurement operation. Reference operations with the Roto system only require a negligible period of time.

A direct product comparison is possible in the matrix opposite. Roto measurement systems comprise the individual components of sensor and magnetic band or ring. The available sensors support signal evaluation via digital outputs or analog interfaces. Corresponding individual components can be combined and

	
Magnetic ring	
Up to 200 000 pulses/ rev.	
Accuracy up to 0.1°	
Sensors	
Direct connection to translation module and magnetic displays	
Max. tolerance of reading distance to scale 2 mm	
Translation module	
Incremental position tracking	
Real-time signal processing	
Resolutions up to 0.0018°	

therefore adapted optimally to existing measuring conditions. Values obtained in a rotary system are either displayed directly (e.g., speed monitoring) or can be processed in follow-on electronic units or higher-level controllers.





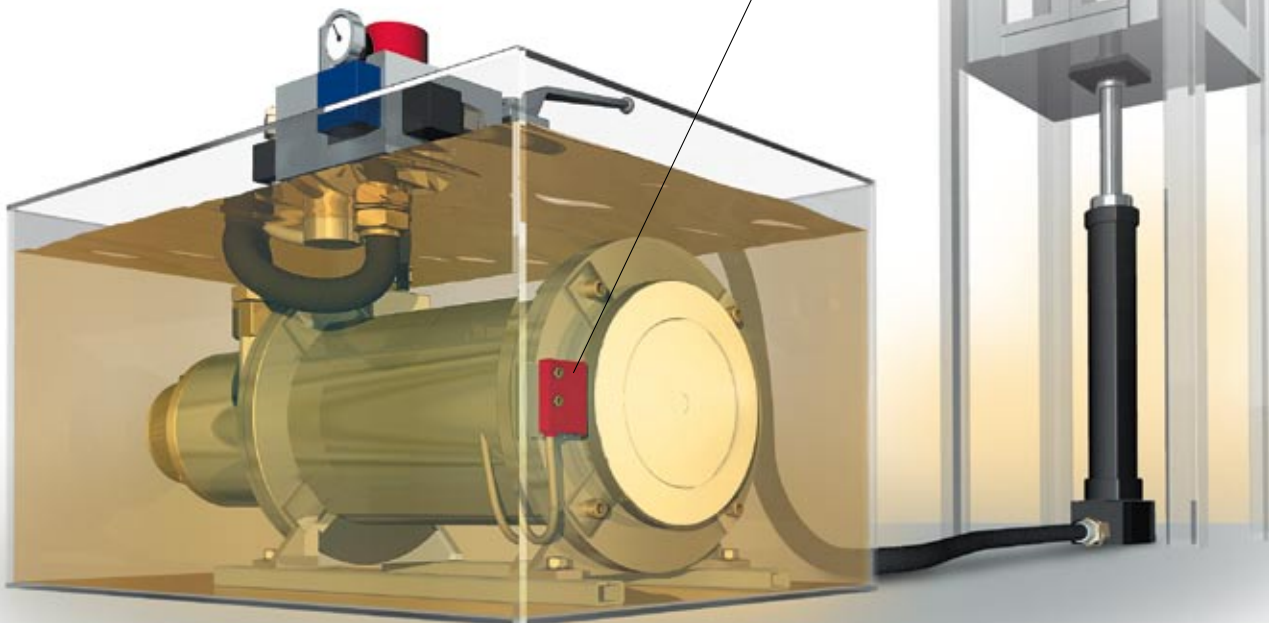



5.4









The measuring system even tracks the motor speed reliably in an oil bath and forwards the values to controllers.



MagLine Roto

Signal analysis via	Incremental systems							
	Output, analog	Output, digital						
System accuracy class (mm)	*)	*)	±0.1°	±0.1°	±0.5°	*)	±0.1°	*)
Maximum repeat accuracy (increment)	-	±1	±1	±1	±1	±1	±1	±1
Maximum reading distance (without reference point, mm)	0.4	0.8	0.8	2.0	2.0	2.0	2.0	2.0

Supply voltage	Output/ interface	Magnetic sensor	Page						
10.5 ... 30 V DC 5 V DC	1 V _{SS}	LE100/1	154						
24 V DC 5 V DC	PP, LD, TTL	MSK210	157						
24 V DC 5 V DC	PP, LD, TTL	MSK320	160						
6.5 ... 30 V DC 4.75 ... 6 V DC	PP, LD	MSK5000	163						

Max. number of poles	Max. pulses/ revolution	Magnetic ring	Page						
100	2 000	MR200	138						
250	5 000	MR320	140						
160	200 000	MR500	142						
64	1 280	MRI01	144						
1120	1 120 **)	MBR100	146						
230	4 600	MBR200	148						
250	5 000	MBR320	150						
210	262 500	MBR500	152						

*) depends on mounting type **) Periods/revolution

Profile

- Easy hollow-shaft mounting
- Rotary encoder system with IP67 protection category (in combination with MSK210)
- Up to 2000 pulses/revolution
- With reference point as an option

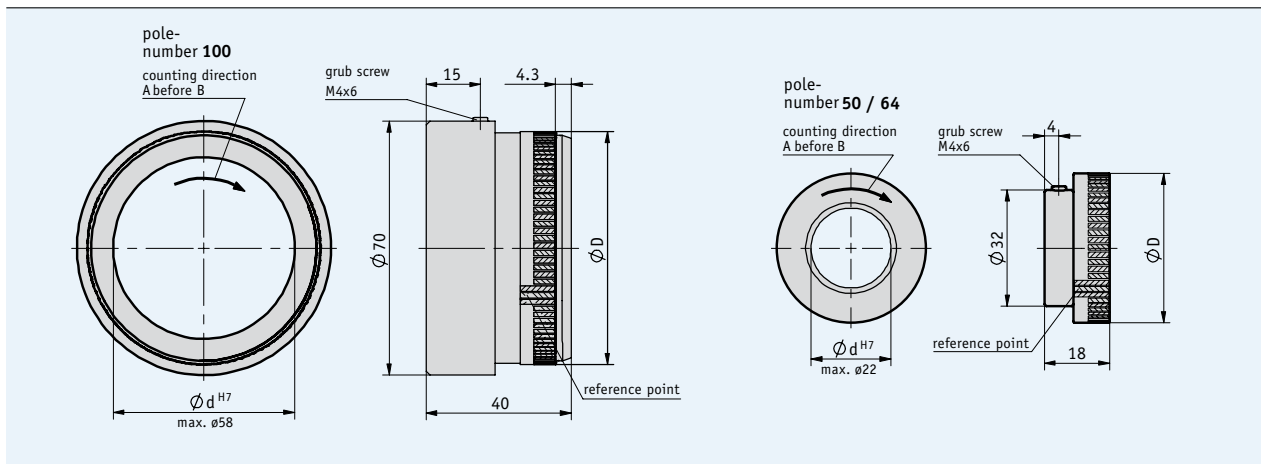

Mechanical data

Feature	Technical data	Additional information
Pole length	2 mm	
Measurement range	360°	
System accuracy	±0.1°	
Operating temperature	0 ... +60 °C	others on request
Storage temperature	-20 ... +70 °C	others on request
Protection category	IP67 according to DIN VDE 0470	
Humidity	100 % rh	condensation permitted
Flange material	aluminum	

■ Dimensions

Poles	50	64	100
Diameter D (mm)	32.3	41.2	64.14
Circumference (mm)	100	130	200
Speed n (rpm)	15000	11500	7500

■ Pulses/revolution

		Number of poles 50	Number of poles 64	Number of poles 100
Scaling factor	20	1000	1280	2000
Sensor	16	800	1024	1600
	10	500	640	1000
	8	400	512	800
	5	250	320	500
	4	200	256	400
	1	50	64	100

The table applies to the combination of MR200 with MSK210

Order

Order table

Feature	Order data	Specifications	Additional information
Number of poles	50	A poles distributed on circumference	hard ferrite
	64		hard ferrite
	100	poles distributed on circumference	flexible magnetic band
		others on request	
Bore diameter	20	B 20 H7	
		others on request	
Fastening type	MNG	C hub thread	
	ONG	without hub thread	
Reference point	O	D without	
	M	with	

Order code

MR200 - - - -

Scope of delivery: MR200, User information

Additional information:

Short Description, Technical Details
Product Overview

Page 136 cont.
Page 4 cont.

Profile

- Easy hollow-shaft mounting
- Rotary encoder system with IP67 protection category (in combination with MSK320)
- Up to 5000 pulses/revolution ($\approx 20\,000$ increments)
- With reference point as an option

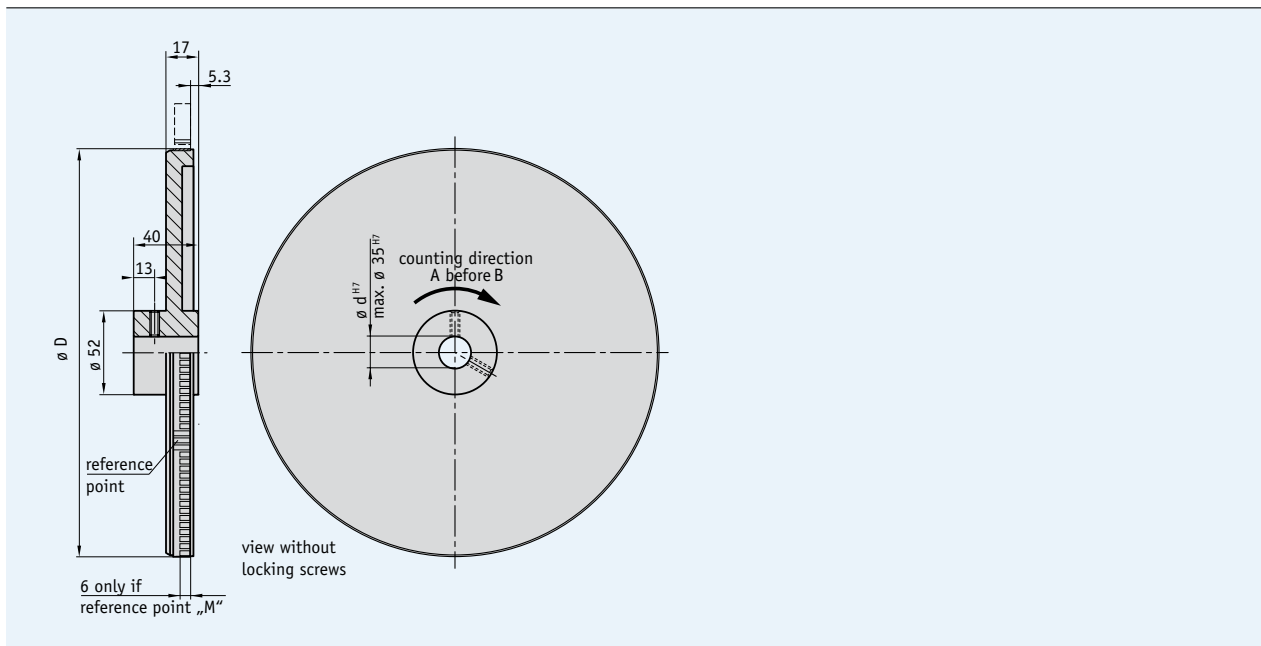

Mechanical data

Feature	Technical data	Additional information
Pole length	3.2 mm	
Measurement range	360°	
System accuracy	$\pm 0.1^\circ$	
Operating temperature	0 ... +60 °C	
Storage temperature	-20 ... +70 °C	
Humidity	100 % rh	condensation permitted
Flange material	aluminum	

■ Dimensions

Pole	100	150	180	250
Diameter D (mm)	100	151	181	253
Circumference (mm)	320	480	570	800
Speed n (rpm)	4687.50	3125.00	2631.00	1875.00

■ Pulses/revolution

		Number of poles 100	Number of poles 150	Number of poles 180	Number of poles 250
Scaling factor of sensor	20	2000	3000	3600	5000
	16	1600	2400	2880	4000
	10	1000	1500	1800	2500
	8	800	1200	1440	2000
	5	500	750	900	1250
	4	400	600	720	1000
	1	100	150	180	250

The table applies to the combination of MR320 with MSK320

Order

■ Order table

Feature	Order data	Specifications	Additional information
Number of poles	100	A 100 poles, distributed on circumference	
	150		150 poles, distributed on circumference
	180		180 poles, distributed on circumference
	250		250 poles, distributed on circumference
			others on request
Bore diameter	20	B 20 H7	
			others on request
Reference point	0	C without	
	M		with

■ Order code

MR320 - - - MNG -

Scope of delivery: MR320, User information

Additional information:

Short Description, Technical Details
Product Overview

Page 136 cont.
Page 4 cont.

Magnetic Ring MR500

Incrementally coded ring with permanently connected flange, pole length 5 mm

Profile

- Easy hollow-shaft mounting
- Rotary encoder system with IP67 protection category (in combination with MSK500)
- Up to 200 000 pulses/revolution (\approx 800 000 increments)
- With reference point as an option

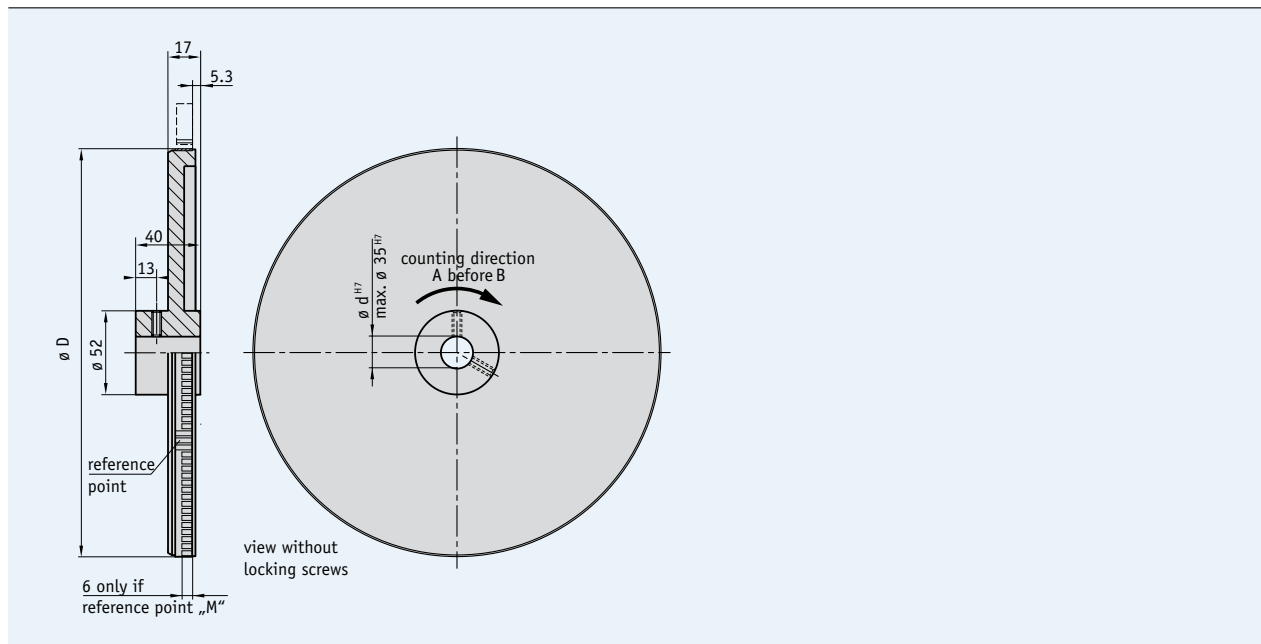

Mechanical data

Feature	Technical data	Additional information
Pole length	5 mm	
Measurement range	360°	
System accuracy	$\pm 0.1^\circ$	
Operating temperature	0 ... +60 °C	
Storage temperature	-20 ... +70 °C	
Humidity	100 % rh	condensation permitted
Flange material	aluminum	

■ Dimensions

Pole	64	96	160
Diameter D (mm)	102	153	255
Circumference (mm)	320	480	800

Pulses/revolution

		Number of poles 64	Number of poles 96	Number of poles 160
Scaling factor of sensor	1250	80000	120000	200000
	250	16000	24000	40000
	125	8000	12000	20000
	50	3200	4800	8000
	25	1600	2400	4000
	12.5	800	1200	2000

The table applies to the combination of MR500 with MSK5000

Speed

The maximum speeds are calculated in reference to the circumferential speed, whereby the circumference of the fitted magnetic ring is decisive. On the MSK5000 sensor, the circumferential speed is variable; it results from the selection of the pulse interval and the scaling factor (refer to table MSK5000). The speed is calculated with the following formula:

Number of poles	U (m)	n (rpm)
64	0.32	variable
96	0.48	variable
160	0.80	variable

$$\text{Speed } n = \frac{v \times 60}{U}$$

v = circumferential speed (m/s); U = circumference (m)
60 = extension factor (60 s/min)

Example:

$$\text{MSK5000 } n = \frac{6 \times 60}{0.32} = 1125 \text{ (rpm)}$$

Order

Order table

Feature	Order data	Specifications	Additional information
Number of poles	64	A 64 poles, distributed on circumference	
	96		
	160		
Bore diameter	20	B 20 H7	
Reference point	O	C without	
	M		

Order code

MR500 - - - MNG -

Scope of delivery: MR500, User information

Additional information:

Short Description, Technical Details
Product Overview

Page 136 cont.
Page 4 cont.

Profile

- Easy hollow-shaft mounting
- Rotary encoder system with IP67 protection category (in combination with MSK320)
- Up to 1280 pulses/revolution (≈ 5120 increments)

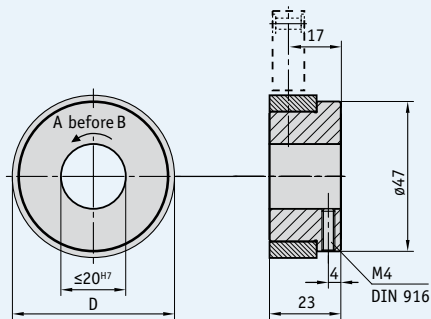

Mechanical data

Feature	Technical data	Additional information
Pole length	2.453 mm	
Measurement range	360°	
System accuracy	$\pm 0.5^\circ$	
Operating temperature	0 ... +60 °C	
Storage temperature	-20 ... +85 °C	
Humidity	100 % rh	condensation permitted
Flange material	aluminum	

Dimensions

Pole	64
Diameter D (mm)	50
Circumference (mm)	157
Speed n (rpm)	9554.14

Pulses/revolution

		Number of poles 64
Scaling factor of sensor	20	1280
	16	1024
	10	640
	8	512
	5	320
	4	256
	1	64

The table applies to the combination of MRI01 with MSK320

Order

Order table

Feature	Order data	Specifications	Additional information
Number of poles	64 A	64 poles distributed on circumference others on request	
Bore diameter	20 B	20 H7	max. 20 H7
	9	9 H8 others on request	

Order code

MRI01 - - - MNG

Scope of delivery: MRI01, User information

Additional information:

Short Description, Technical Details
Product Overview

Page 136 cont.
Page 4 cont.

Magnetic Ring MBR100

Incremental, flexible magnetic band ring for self-assembly, pole length 1 mm

Profile

- With reference point as an option
- Easy mounting on self-made carrier

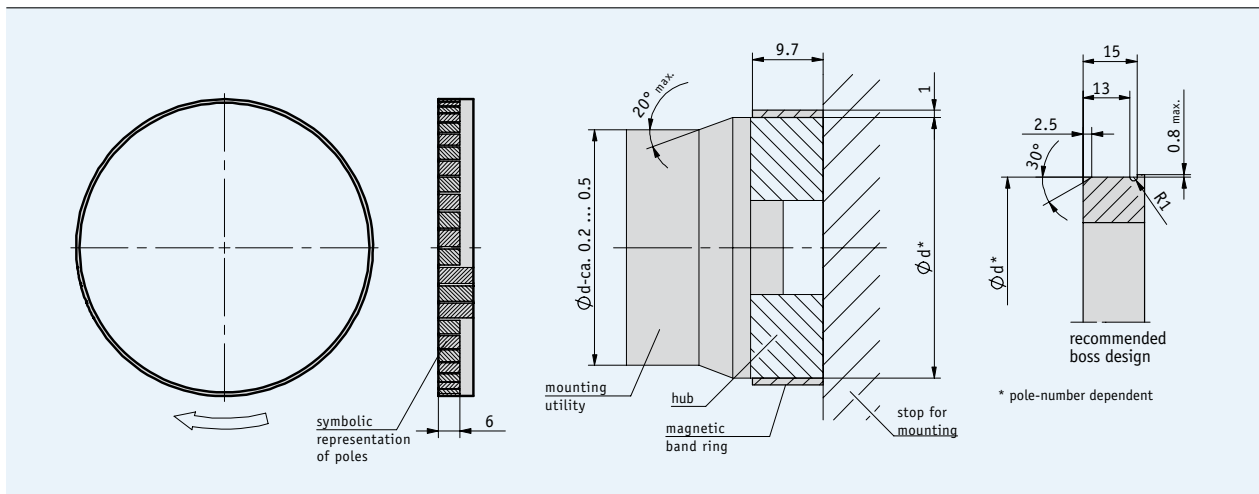

Mechanical data

Feature	Technical data	Additional information
Pole length	1 mm	
Measuring length	360°	
Band width	10 mm	
Thickness	1 mm	without cover and adhesive carrier strip
Operating temperature	0 ... +60 °C	
Storage temperature	-20 ... +70 °C	
Humidity	100 % rh	condensation permitted
Mounting type	glued joint	recommended two-component adhesive: Uhu Plus 300 Endfest
Minimum diameter	40 mm	
Maximum diameter	400 mm	

■ Dimensions for magnetic band ring accommodation

Poles	460	540	720	1120
Diameter d (mm)	144.7 ±0.03	170.1 ±0.03	227.4 ±0.03	354.74 ±0.03
Circumference (mm)	460	540	720	1120
Speed n (rpm)	3274.77	2220.60	1665.94	1071.27

■ Periods/revolution

Number of poles	460	540	720	1120
Period	460	540	720	1120

The table applies to the combination of MBR100 with LE100/1

Order

Order table

Feature	Order data	Specifications	Additional information
Number of poles	460	A 460 poles	
	540		540 poles
	720		720 poles
	1120		1120 poles
			others on request
Reference point	O	B without	
	M		with

Order code

MBR100 - -
A B

Scope of delivery: MBR100, User information

Additional information:

Short Description, Technical Details
 Product Overview

Page 136 cont.
 Page 4 cont.

Magnetic Ring MBR200

Incremental, flexible magnetic band ring for self-assembly, pole length 2 mm

Profile

- With reference point as an option
- Easy mounting on self-made carrier

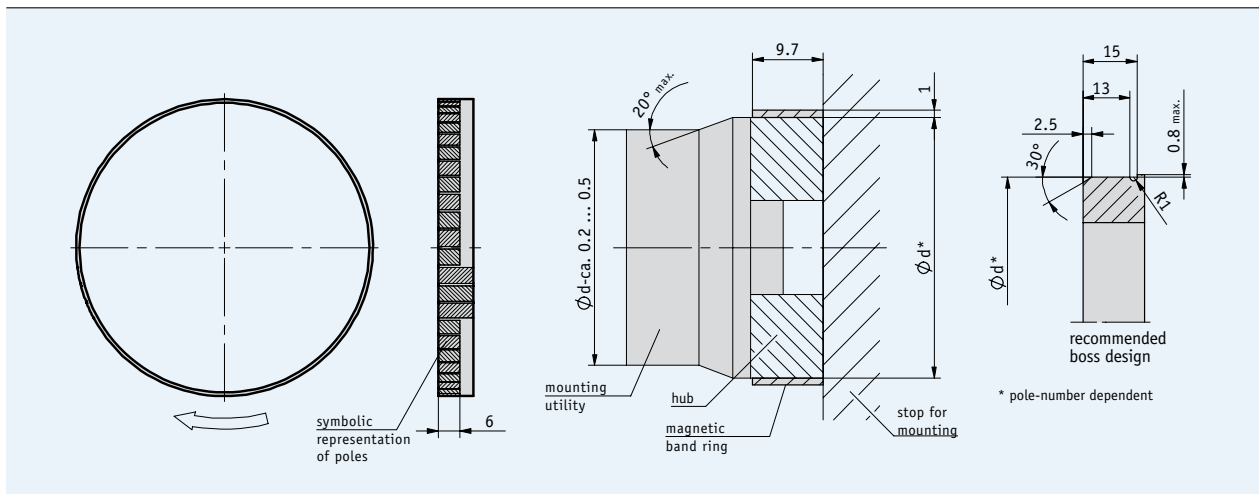

Mechanical data

Feature	Technical data	Additional information
Pole length	2 mm	
Measuring length	360°	
Band width	10 mm	
Thickness	1 mm	without cover and adhesive carrier strip
Operating temperature	0 ... +60 °C	
Storage temperature	-20 ... +70 °C	
Humidity	100 % rh	condensation permitted
Mounting type	glued joint	recommended two-component adhesive: Uhu Plus 300 Endfest

- **Dimensions** for magnetic band ring accommodation

Poles	50	64	100	230
Diameter d (mm)	30.7 ±0.03	39.6 ±0.03	62.6 ±0.03	144.7 ±0.03
Circumference (mm)	100	130	200	370
Speed n (rpm)	14608.78	11483.34	7394.85	4093.46

Pulses/revolution

		Number of poles 50	Number of poles 64	Number of poles 100	Number of poles 230
Scaling factor of sensor	20	1000	1280	2000	4600
	16	800	1024	1600	3680
	10	500	640	1000	2300
	8	400	512	800	1840
	5	250	320	500	1150
	4	200	256	400	920
	1	50	64	100	230

The table applies to the combination of MBR200 with MSK210

Order

Order table

Feature	Order data	Specifications	Additional information
Number of poles	50	50 poles	
	64	64 poles	
	100	100 poles	
	230	230 poles	
		others on request	
Reference point	0	without	
	M	with	

Order code

MBR200 - -
A B

Scope of delivery: MBR200, User information

Additional information:

Short Description, Technical Details
 Product Overview

Page 136 cont.
 Page 4 cont.

Profile

- With reference point as an option
- Easy mounting on self-made carrier

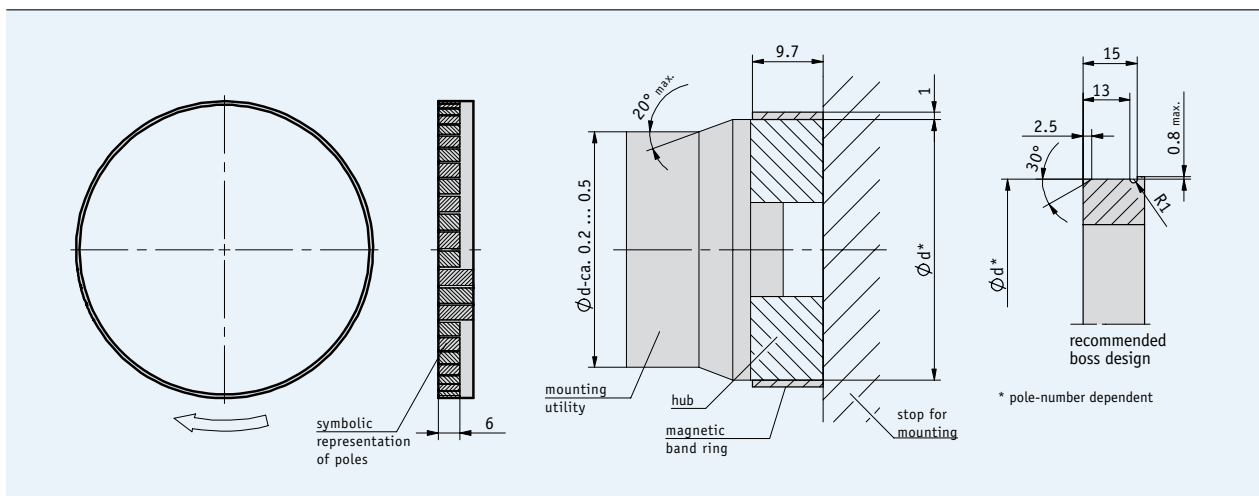

Mechanical data

Feature	Technical data	Additional information
Pole length	3.2 mm	
Measuring length	360°	
Band width	10 mm	
Thickness	1 mm	without cover and adhesive carrier strip
Operating temperature	0 ... +60 °C	
Storage temperature	-20 ... +70 °C	
Humidity	100 % rh	condensation permitted
Mounting type	glued joint	recommended two-component adhesive: Uhu Plus 300 Endfest

■ Dimensions for magnetic band ring accommodation

Poles	36	50	100	150	180	250
Diameter d (mm)	35.7 ±0.03	49 ±0.03	100.9 ±0.03	151.8 ±0.03	182.4 ±0.03	253.7 ±0.03
Circumference (mm)	120	160	320	480	580	1117
Speed n (rpm)	12671.27	9366.80	4642.44	3106.03	2590.60	1339.09

Pulses/revolution

		Number of poles 36	Number of poles 50	Number of poles 100	Number of poles 150	Number of poles 180	Number of poles 250
Scaling factor of sensor	20	720	1000	2000	3000	3600	5000
	16	576	800	1600	2400	2880	4000
	10	360	500	1000	1500	1800	2500
	8	288	400	800	1200	1440	2000
	5	180	250	500	750	900	1250
	4	144	200	400	600	720	1000
	1	36	50	100	150	180	250

The table applies to the combination of MBR320 with MSK320

Order

Order table

Feature	Order data	Specifications	Additional information
Number of poles	36	A 36 poles 50 poles 100 poles 150 poles 180 poles 250 poles others on request	
	50		
	100		
	150		
	180		
	250		
Reference point	O	B without with	
	M		

Order code

MBR320 - -
A B

Scope of delivery: MBR320, User information

Additional information:

Short Description, Technical Details
Product Overview

Page 136 cont.
Page 4 cont.

Magnetic Ring MBR500

Incremental, flexible magnetic band ring for self-assembly, pole length 5 mm

Profile

- With reference point as an option
- Easy mounting on self-made carrier

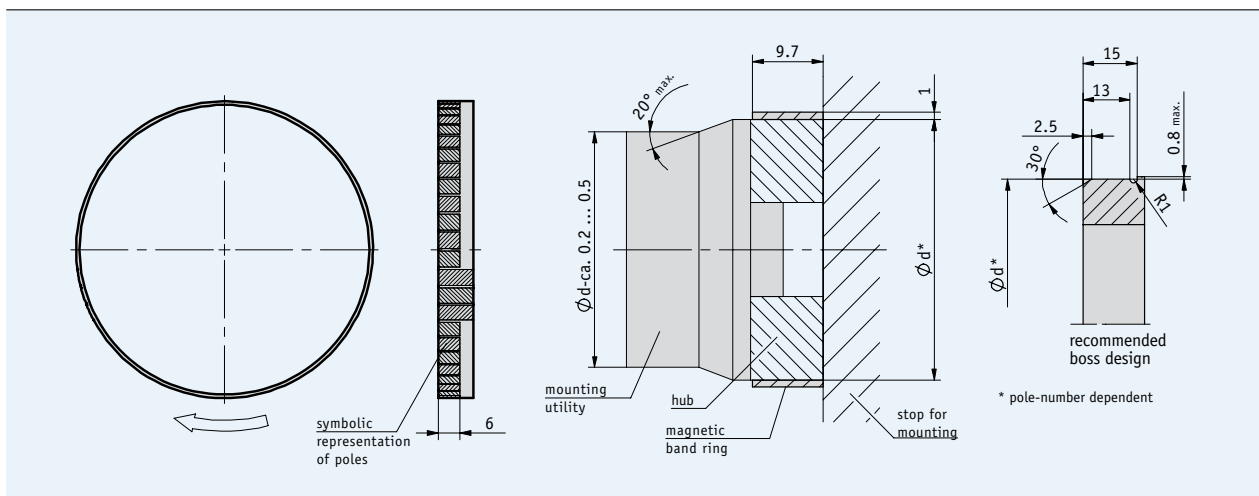

Mechanical data

Feature	Technical data	Additional information
Pole length	5 mm	
Measuring length	360°	
Band width	10 mm	
Thickness	1 mm	without cover and adhesive carrier strip
Operating temperature	0 ... +60 °C	
Storage temperature	-20 ... +70 °C	
Humidity	100 % rh	condensation permitted
Mounting type	glued joint	recommended two-component adhesive: Uhu Plus 300 Endfest

- **Dimensions** for magnetic band ring accommodation

Poles	36	50	64	96	160	188
Diameter d (mm)	57.5 ±0.03	79.8 ±0.03	102 ±0.03	153 ±0.03	254.8 ±0.03	299.4 ±0.03
Circumference (mm)	190	260	330	490	810	950

Pulses/revolution

		Number of poles 36	Number of poles 50	Number of poles 64	Number of poles 96	Number of poles 160	Number of poles 188
Scaling factor of sensor	1250	45000	62500	80000	120000	200000	235000
	250	9000	12500	16000	24000	40000	47000
	125	4500	6250	8000	12000	20000	23500
	50	1800	2500	3200	4800	8000	9400
	25	900	1250	1600	2400	4000	4700
	12.5	450	625	800	1200	2000	2350

The table applies to the combination of MBR500 with MSK5000

Speed

The maximum speeds are calculated in reference to the circumferential speed, whereby the circumference of the fitted magnetic ring is decisive. On the MSK5000 sensor, the circumferential speed is variable; it results from the selection of the pulse interval and the scaling factor (refer to table MSK5000). The speed is calculated with the following formula:

$$\text{Speed } n = \frac{v \times 60}{U}$$

v = circumferential speed (m/s); U = circumference (m)
60 = extension factor (60 s/min)

Example:

$$\text{MSK5000 } n = \frac{6 \times 60}{0.32} = 1125 \text{ (rpm)}$$

Number of poles	U (mm)	n (rpm)
36	190	variable
50	260	variable
64	330	variable
96	490	variable
160	810	variable
188	950	variable

Order

Order table

Feature	Order data	Specifications	Additional information
Number of poles	36	36 poles	
	50	50 poles	
	64	64 poles	
	96	96 poles	
	160	160 poles	
	188	188 poles	
		others on request	
Reference point	0	without	
	M	with	

Order code

MBR500 - -
 A B

Scope of delivery: MBR500, User information

Additional information:

Short Description, Technical Details
Product Overview

Page 136 cont.
Page 4 cont.

Magnetic Sensor LE100/1

Incremental, analog interface 1 V_{SS}

Profile

- Accuracy class $\pm 0.1^\circ$
- Output circuit sin/cos 1 V_{SS}
- Status LED display
- Robust metal housing
- Scale MBR100
- Signal period 1000 μm

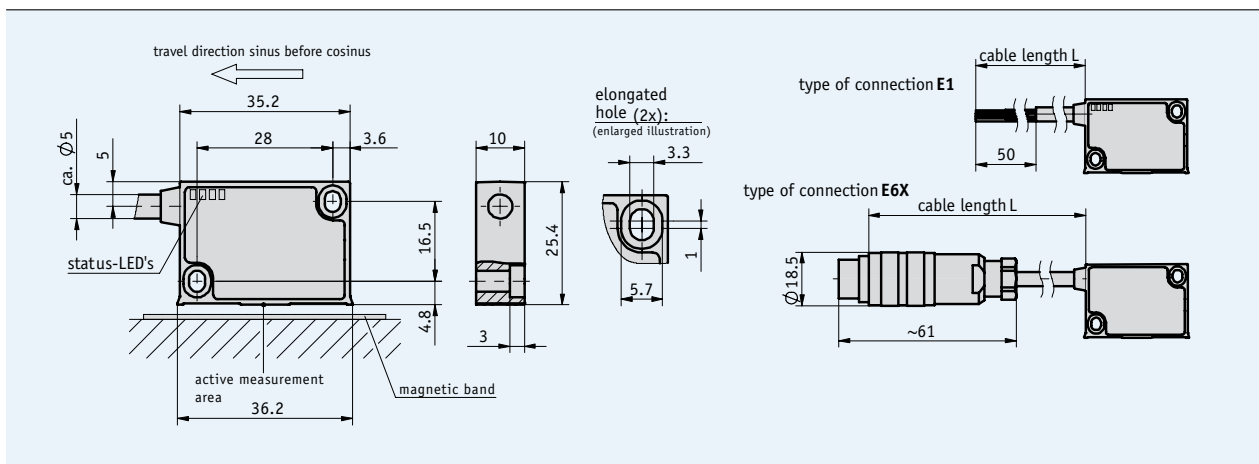

Mechanical data

Feature	Technical data	Additional information
Scale embodiment	MBR100	
System accuracy	max. 1 % related to division period	
Sensor/ring reading distance	0.1 ... 0.4 mm 0.1 ... 0.2 mm	with reference signal 0, IA, ID with reference signal RB
Circumferential speed	max. 20 m/s	
Housing	zinc die-cast	
Sensor cable	PUR	drag chain-compatible
Operating temperature	-10 ... +70 °C	
Storage temperature	-30 ... +80 °C	
Humidity	100 % rh	condensation permitted
Protection category	IP67	
Vibration resistance	<200 m/s ² (50 ... 2000 Hz)	
Max. measuring length	infinite	

Electrical data

Feature	Technical data	Additional information
Operating voltage	10.5 ... 30 V DC 5 V DC ±5 %	reverse-polarity protection on UB no reverse-polarity protection on UB
Current consumption	<25 mA <50 mA	with 24 V with 5 V
Type of connection	flying leads round connector	
Output circuit	1 V _{SS}	
Output signals	sin, cos, /sin, /cos, I, /I, or R, /R	
Pulse width of reference signal	see the drawing of the signal shape	
Interference protection class	3	according to IEC 801
Real-time requirement	real-time signal processing	
Signal amplitude	1 V _{SS} ±10 %	at 0-70 °C with RA = 120 Ohm to 1 kOhm
Output impedance	0 Ohm (Rload >75 Ohm)	short-circuit-proof
Offset sine/cosine	2.5 V ±100 mV UB/2 ±100 mV	
Phasing sine/cosine	90° ±1°; < ±3° (20 kHz)	
Phasing of reference signal	sin 45, cos 135°	
Signal period	1000 µm	

Signal forms

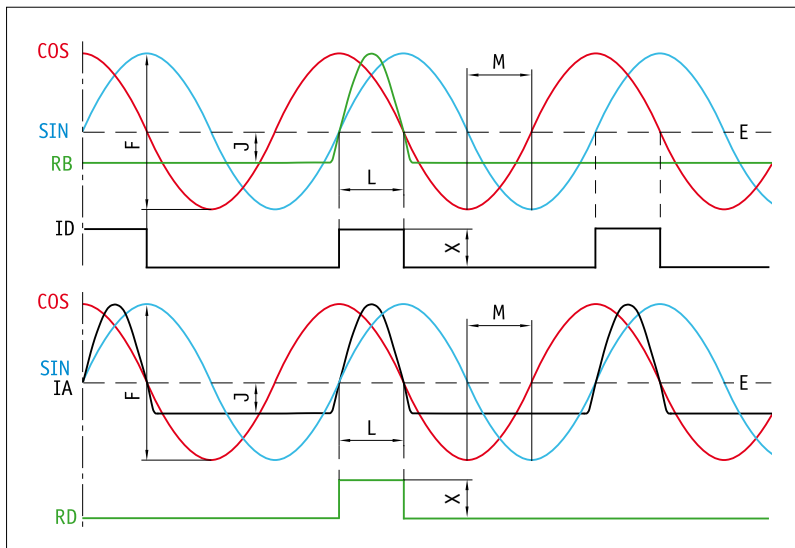

E: reference voltage 2.5 V
 F: 1 V_{SS} ±10 %
 J: ≥0.2 V
 L: 100° ±20°
 M: 90° ±1.0° / < ±3° (25 kHz)
 X: 1 V_{SS}

Pin assignment

without reference signal

Signal	E1	E6X
GND	black	1
sin	red	2
/sin	orange	3
cos	yellow	4
/cos	green	5
+UB	brown	6
N.C.		7

with reference signal

Signal	E1	E6X
sin	red	1
cos	yellow	2
index	blue	3
+UB	brown	4
GND	black	5
/sin	orange	6
/cos	green	7
/index	violet	8

Mounting instruction

On systems with reference points on the magnetic ring, please ensure the correct alignment of the sensor and band.

Reference signal	O, IA, ID	RB, RD
Sensor/band reading distance A	max. 0.4 mm	max. 0.2 mm
Lateral offset B	max. ±2 mm	max. ±0.5 mm

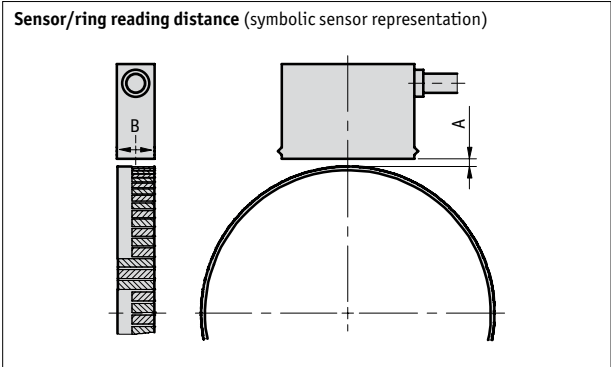

Order

Order table

Feature	Order data	Specifications	Additional information
Operating voltage	10	10.5 ... 30 V DC	
	5	5 V DC ±5 %	
Type of connection	E1	flying leads	
	E6X	round connector	
		cable extensions on request	
Cable length L	...	1 ... 20 m, in steps of 1 m	
Reference signal	O	without	
	IA	index periodic	analog index signal every 1 mm
	ID	index periodic	digital index signal every 1 mm
	RB	fixed, band side	analog reference signal
	RD	fixed, band side	digital reference signal

Order code

LE100/1 - - - - -

A B C D S

Scope of delivery: LE100/1, User information, Allen fastening screws M3 x 14 mm ISO 4762, lock washers M3 DIN 7980, strain relief for sensor cable, distance gage 0.2 mm

Additional information:

Short Description, Technical Details
Product Overview

Page 136 cont.
Page 4 cont.

Profile

- Resolution 0.045° with MR200 and MBR200 (100 poles)
- Max. 4600 pulses/revolution with MBR200 (230 poles)
- Max. 18 400 increments/revolution with quadrature evaluation
- Repeat accuracy ±1 increment

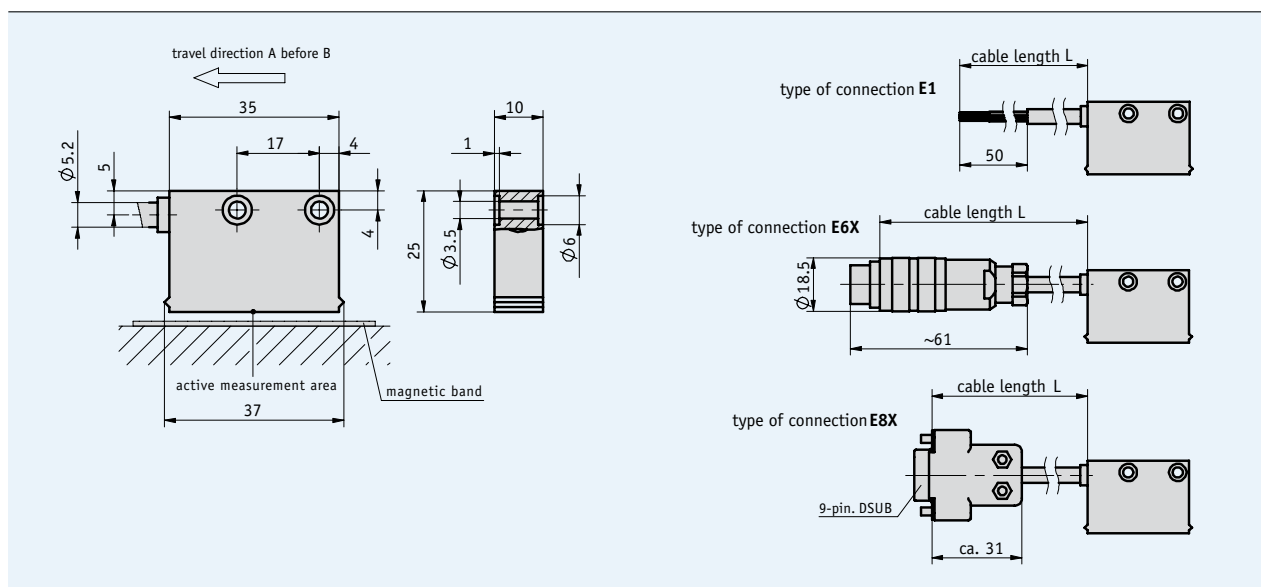

5.4

Mechanical data

Feature	Technical data	Additional information
Scale embodiment	MR200 MBR200	
System accuracy	±0.1°	
Repeat accuracy	±1 increment	
Sensor/ring reading distance	0.1 ... 0.8 mm 0.1 ... 0.4 mm	with reference signals O, I with reference signal R
Circumferential speed	max. 25 m/s	max. referencing speed 2 m/s
Housing	plastic, green	
Sensor cable	PUR	
Operating temperature	-10 ... +70 °C	
Storage temperature	-30 ... +80 °C	
Humidity	100 % rh	condensation permitted
Protection category	IP67	
Vibration resistance	10 g/50 Hz	
Max. measurement range	infinite	

Electrical data

Feature	Technical data	Additional information
Operating voltage	24 V DC \pm 20 % 5 V DC \pm 5 %	reverse-polarity protection on UB no reverse-polarity protection on UB
Current consumption	max. 70 mA	24 V no load
Type of connection	flying leads round connector D-SUB 9-pin	
Output circuit	PP LD TTL	PP only with 24 V
Output signals	A, B A, /A, B, /B, option: I, /I, or R, /R	quadrature signal
Max. pulses/revolution rotary	max. 2000 pulses/revolution	with MR or MBR200
Pulse width of reference signal	1 increment	
Scaling factor	1, 4, 5, 8, 10, 16, 20	
Jitter	<15 % with reading distance of 0.5 mm	sensor/magnetic ring reading distance 0.5 mm
Interference protection class	3	according to IEC 801
Real-time requirement	real-time signal processing	
Signal level high	>UB – 2.5 V >2.5 V >2.4 V	with PP with LD with TTL
Signal level low	<0.8 V <0.5 V <0.4 V	with PP with LD with TTL

Signal forms

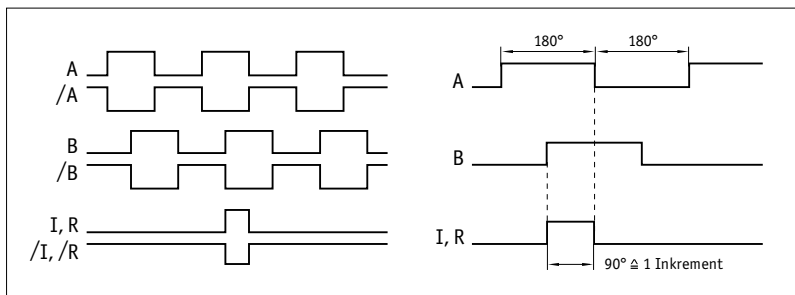

! The logical condition of signals A and B is not defined in reference to the index signal I or the reference signal R. It can deviate from the signal form.

Pin assignment

non-inverted

Signal	E1	E6X	E8X
A	red	3	3
B	orange	4	4
+UB	brown	2	2
GND	black	1	1
N.C.		5,6,7	5,6,7,8,9

inverted

Signal	E1	E6X	E8X
A	red	1	1
B	orange	2	2
+UB	brown	4	4
GND	black	5	5
A/	yellow	6	6
B/	green	7	7
N.C.		3	3, 8, 9

inverted with reference signal

Signal	E1	E6X	E8X
A	red	PIN 1	PIN 1
B	orange	2	2
I	blue	3	3
+UB	brown	4	4
GND	black	5	5
A/	yellow	6	6
B/	green	7	7
I/	violet	8	8
N.C.			9

Mounting instruction

On systems with reference points on the magnetic ring, please ensure the correct alignment of the sensor and band.

Reference signal	0, I	R
Sensor/band reading distance A	max. 0.8 mm	max. 0.4 mm
Lateral offset B	max. ±2 mm	max. ±0.5 mm

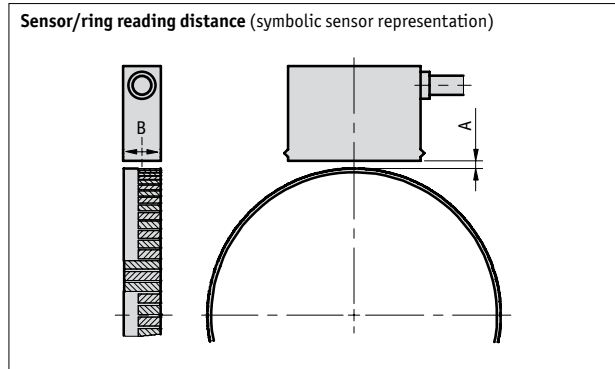

Order

Order table

Feature	Order data	Specifications	Additional information
Operating voltage	4	24 V DC ±20 %	reverse-polarity protection
	5	5 V DC ±5 %	
Type of connection	E1	flying leads	
	E6X	round connector without mating connectors	
	E8X	D-SUB 9-pin without mating connectors	
		cable extensions on request	
Cable length L	...	1 ... 20 m, in steps of 1 m	
Output circuit	PP	push-pull	only with operating voltage 4
	LD	line driver	
	TTL		only with non-inverted output signal, max. 5 m cable length
Output signal	NI	non-inverted	
	I	inverted	with reference signal I or R
Reference signal	0	without	
	I	index periodic	
	R	index fixed	not with scaling factor 1
Scaling factor	...	1, 10, 20	

Order code

MSK210 - - - - - - - -

A B C D E F G

Scope of delivery: MSK210, User information, Allen fastening screws M3 x 14 mm ISO 4762, lock washers M3 DIN 7980, strain relief for sensor cable, distance gage 0.3 mm

Additional information:

Short Description, Technical Details
Product Overview

Page 136 cont.
Page 4 cont.

Profile

- Max. resolution 0.018° with MR320
- Max. 5000 pulses/revolution with MR320 and MBR320 (250 poles)
- Max. 20 000 increments/revolution with quadrature evaluation
- Repeat accuracy of ±1 increment

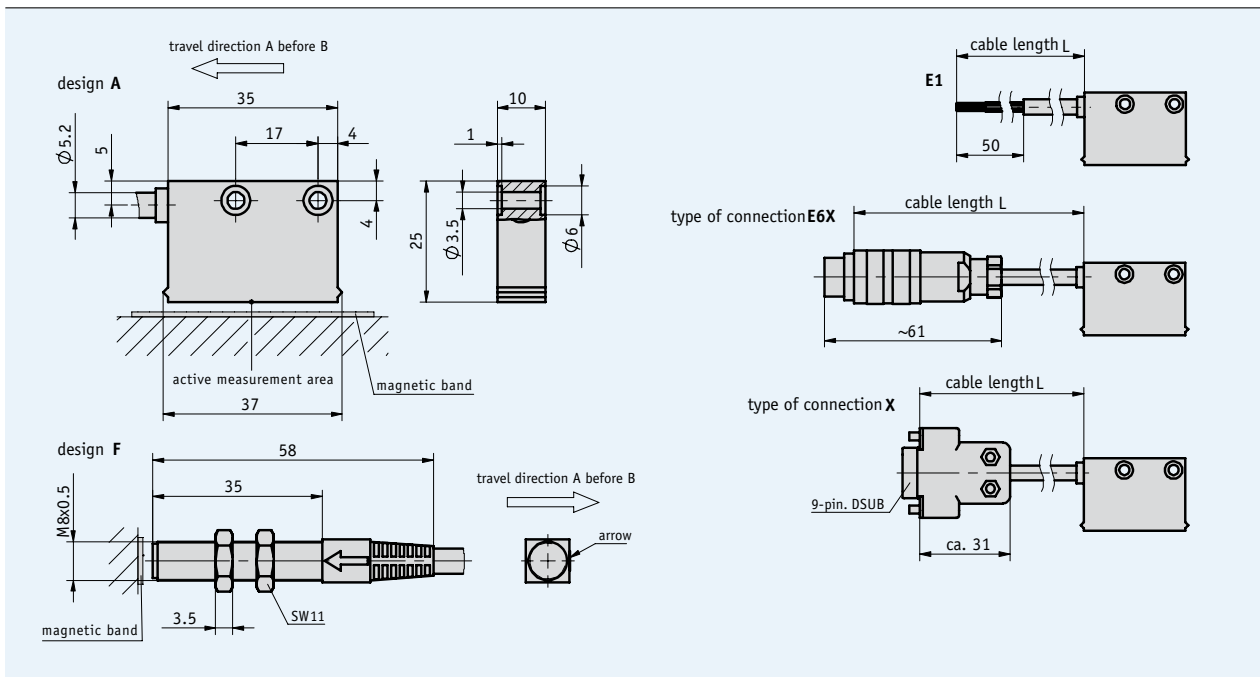

Mechanical data

Feature	Technical data	Additional information
Scale embodiment	MR320 MBR320 MRI01	
System accuracy	± 0.1°	
Repeat accuracy	± 1 increment	
Sensor/ring reading distance	0.1 ... 2 mm 0.1 ... 0.4 mm	with reference signals 0, I with reference signal R
Circumferential speed	max. 25 m/s	max. referencing speed 3.2 m/s
Housing	rectangular housing, plastic red; round housing, steel	
Sensor cable	PUR	
Operating temperature	-10 ... +70 °C	
Storage temperature	-30 ... +80 °C	
Humidity	100 % rh	condensation permitted
Protection category	IP67	
Vibration resistance	10 g/50 Hz	
Max. measuring length	infinite	

Electrical data

Feature	Technical data	Additional information
Operating voltage	24 V DC $\pm 20\%$ 5 V DC $\pm 5\%$	reverse-polarity protection on UB no reverse-polarity protection on UB
Current consumption	max. 70 mA	24 V no load
Type of connection	flying leads round connector D-SUB 9-pin	
Output circuit	PP LD TTL	PP only with 24 V
Output signals	A, /A, B, /B, option: I, /I, or R, /R	quadrature signal
Max. pulses/revolution	max. 5000 pulses/revolution max. 20000 increments/revolution	number of poles 250 when combined with MR/MBR 320
Pulse width of reference signal	1 increment	
Scaling factor	1, 4, 5, 8, 10, 16, 20	
Jitter	<15 %	with reading distance of 0.5 mm
Interference protection class	3	according to IEC 801
Real-time requirement	real-time signal processing	

Signal forms

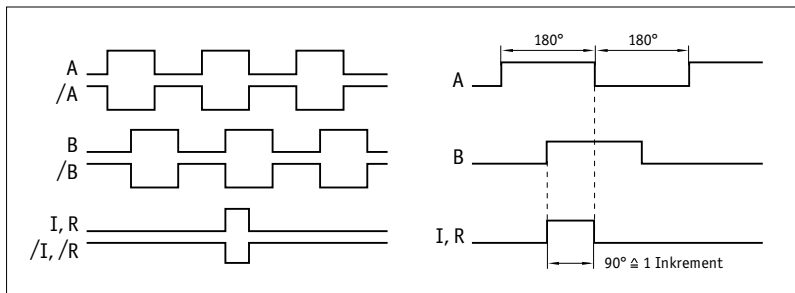

⚠ The logical condition of signals A and B is not defined in reference to the index signal I or the reference signal R. It can deviate from the signal form.

Pin assignment

non-inverted

Signal	E1	E6X	E8X
A	red	3	3
B	orange	4	4
+UB	brown	2	2
GND	black	1	1
N.C.		5,6,7	5,6,7,8,9

inverted

Signal	E1	E6X	E8X
A	red	1	1
B	orange	2	2
+UB	brown	4	4
GND	black	5	5
A/	yellow	6	6
B/	green	7	7
N.C.		3	3, 8, 9

inverted with reference signal

Signal	E1	E6X	E8X
A	red		
B	orange	2	2
I	blue	3	3
+UB	brown	4	4
GND	black	5	5
A/	yellow	6	6
B/	green	7	7
I/	violet	8	8
N.C.			9

Mounting instruction

On systems with reference points on the magnetic ring, please ensure the correct alignment of the sensor and band.

Reference signal	O, I	R
Sensor/band reading distance A	max. 2 mm	max. 1.5 mm
Lateral offset B	max. ±2 mm	max. ±0.5 mm

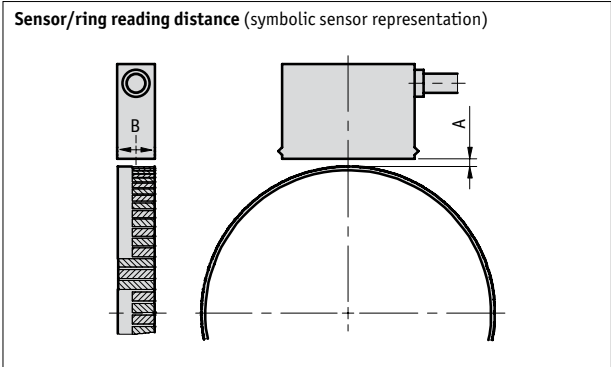

Order

Order table

Feature	Order data	Specifications	Additional information
Operating voltage	4	24 V DC ±20 %	reverse-polarity protection
	5	5 V DC ±5 %	
Sensor design	A	rectangular	
	F	round	
Type of connection	E1	flying leads	
	E6X	round connector without mating connectors	
	E8X	D-SUB 9-pin without mating connectors	
		cable extensions on request	
Cable length L	...	D 1 ... 20 m, in steps of 1 m	
Output circuit	PP	push-pull	only operating voltage 4
	LD	line driver	
	TTL		only with non-inverted output signal, max. 5 m cable length
Output signal	NI	non-inverted	with reference signal I or R
	I	inverted	
Reference signal	O	without	not with scaling factor 1
	I	index periodic	
	R	index fixed	
Scaling factor	...	H 1, 4, 5, 8, 10, 16, 20	F design only possible with scalings 4, 8

Order code

MSK320 - - - - - - - -

A B C D E F G H

Scope of delivery: MSK320, User information, Allen fastening screws M3 x 14 mm ISO 4762, lock washers M3 DIN 7980, strain relief for sensor cable

Additional information:

Short Description, Technical Details
Product Overview

Page 136 cont.
Page 4 cont.

Profile

- Max. resolution up to 262 500 pulses/revolution in combination with MR500 and MBR500 (188 poles)
- Max. 800 000 increments/revolution with 4-fold evaluation for MR500 and MBR500 (188 poles)
- Repeat accuracy of ± 1 increment
- Status LED display

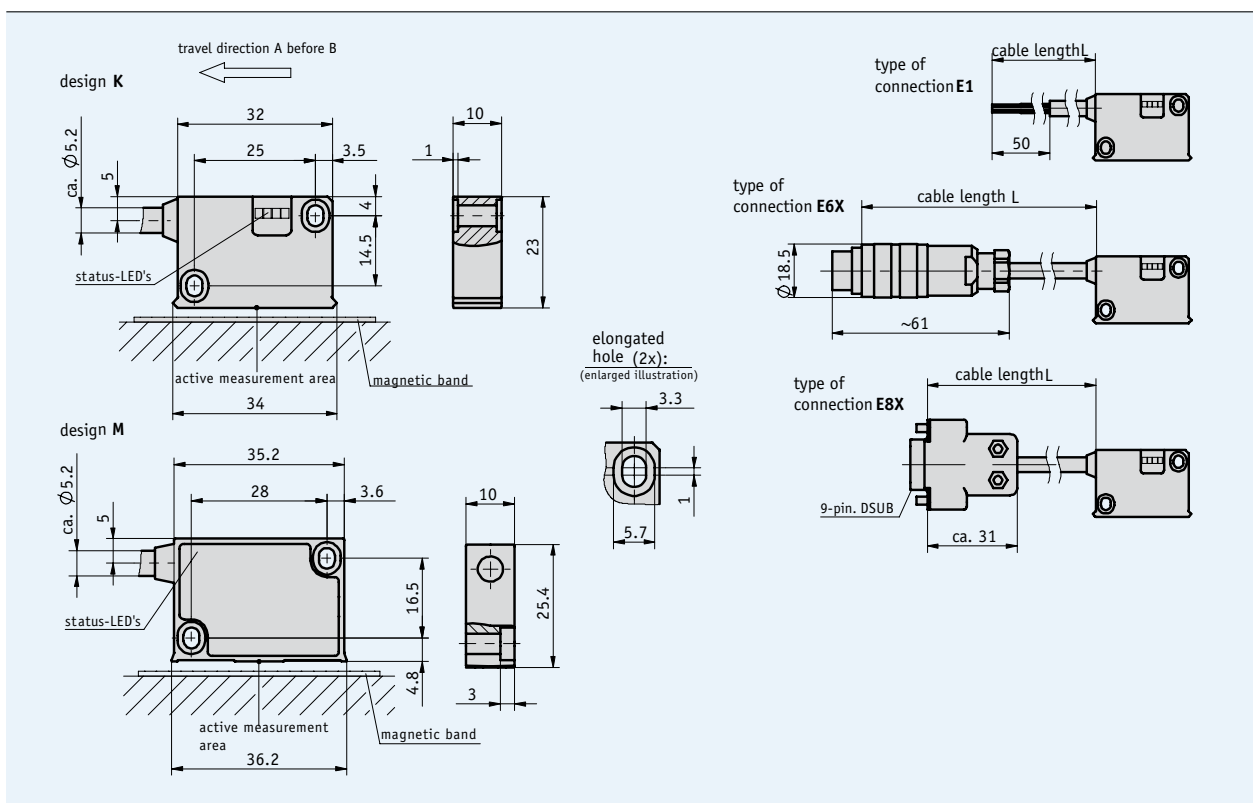

Mechanical data

Feature	Technical data	Additional information
Scale embodiment	MR500 MBR500	
System accuracy	±0.1°	
Repeat accuracy	max. ±10 µm	
Sensor/ring reading distance	0.1 ... 2 mm 0.1 ... 1.5 mm	with reference signals O, I with reference signal R
Circumferential speed	depends on resolution and pulse interval	see table
Housing	plastic, black	
Sensor cable	PUR, drag chain-compatible	
Operating temperature	-10 ... +70°C	
Storage temperature	-30 ... +80°C	
Humidity	100 % rh	condensation permitted
Protection category	IP67	
Vibration resistance	10 g/50 Hz	
Max. measuring length	infinite	

■ Circumferential speed

Scaling factor	circumferential speed V_{max} (m/s)									
	1250	250	125	50	25	12.5	4.00	1.60	0.80	0.32
1250	4.00	20.00	25.00	25.00	25.00	25.00	0.20	8.00	4.00	1.60
250	20.00	8.00	16.00	20.00	25.00	25.00	0.10	1.00	1.60	0.32
125	25.00	16.00	8.00	3.20	2.00	1.00	0.05	0.50	0.25	0.10
50	25.00	25.00	20.00	8.00	5.00	2.50	0.03	1.25	0.63	0.03
25	25.00	25.00	25.00	16.00	10.00	5.00	0.01	2.50	1.25	0.01
12.5	25.00	25.00	25.00	25.00	20.00	10.00	0.01	5.00	2.50	0.01
Pulse interval (µs)	0.20	0.50	1.00	2.50	4.00	8.00	16.00	32.00	66.00	
Counting frequency (kHz)	1250.00	500.00	250.00	100.00	62.50	31.25	15.63	7.81	3.79	

Electrical data

Feature	Technical data	Additional information
Operating voltage	6.5 V DC ... 30 V DC 4.75 V DC ... 6 V DC	reverse-polarity protection on UB no reverse-polarity protection on UB
Current consumption	<25 mA	no load
Type of connection	flying leads round connector D-SUB 9-pin	
Output circuit	PP LD	
Output signals	A, /A, B, /B, option: I, /I or R, /R	
Max. pulses/revolution	max. 40000 pulses/revolution	
Pulse width of reference signal	1 or 4 increments	
Scaling factor	1250, 250, 125, 50, 25, 12.5	
Interference protection class	3	IEC-61000-6-2
Real-time requirement	real-time signal processing	
Signal level high	>UB - 2.5 V >2.5 V	with PP with LD
Signal level low	<0.8 V	

■ Signal forms

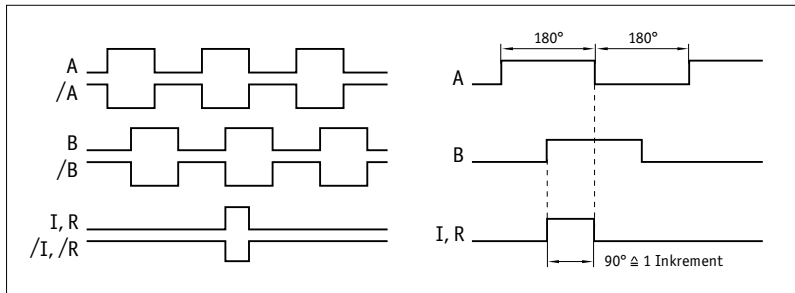

! The logical condition of signals A and B is not defined in reference to the index signal I or the reference signal R. It can deviate from the signal form.

■ Pulse interval

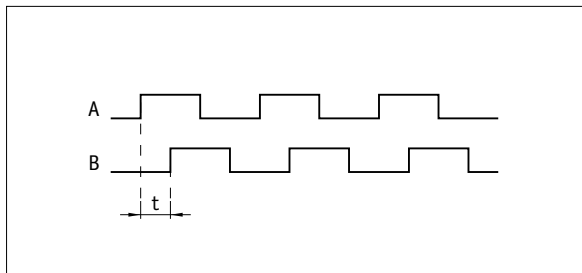

Example: Pulse interval $t = 1 \mu\text{s}$

(i.e., the downstream unit must be able to process 250 kHz)

$$\text{Formula for counting frequency} = \frac{1}{1 \mu\text{s} \times 4} = 250 \text{ kHz}$$

Pin assignment

■ inverted without index signal

Signal	E1	E6X	E8X
A	red	1	1
B	orange	2	2
+UB	brown	4	4
GND	black	5	5
/A	yellow	6	6
/B	green	7	7
N.C.		3	3, 8, 9

■ inverted with index signal

Signal	E1	E6X	E8X
A	red	1	1
B	orange	2	2
I, R	blue	3	3
+UB	brown	4	4
GND	black	5	5
/A	yellow	6	6
/B	green	7	7
/I, /R	violet	8	8
N.C.			9

Mounting instruction

On systems with reference points on the magnetic ring, please ensure the correct alignment of the sensor and band.

Reference signal	O, I	R
Sensor/band reading distance A	max. 2 mm	max. 1.5 mm
Lateral offset B	max. ±2 mm	max. ±0.5 mm

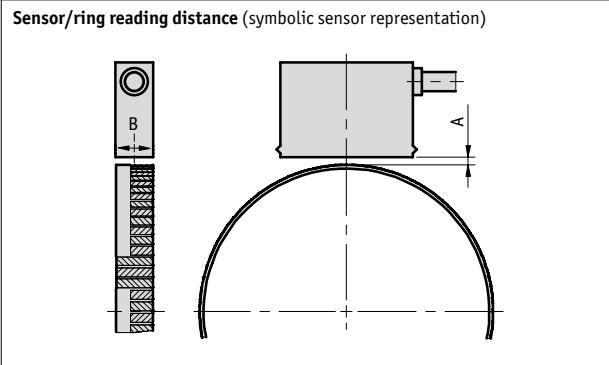

Order

Order table

Feature	Order data	Specifications	Additional information
Operating voltage	10	6.5 ... 30 V DC	
	11	4,75 ... 6 V DC	
Design	K	plastic housing	
	M	metal housing	
Type of connection	E1	flying leads	
	E6X	round connector without mating connectors	
	E8X	D-SUB 9-pin without mating connectors	
		cable extensions on request	
Cable length L	...	1 ... 20 m, in steps of 1 m	
Output circuit	PP	push-pull	only operating voltage 10
	LD	line driver	
Reference signal	O	without	
	I	index periodic	
	R	fixed reference	
Scaling factor	...	12.5, 25, 50, 125, 250, 1250	
Pulse interval in µs	...	0.2, 0.5, 1, 2.5, 4, 8, 16, 32, 66	

Order code

MSK5000 - - - - - - - -

A B C D E F G H

Scope of delivery: MSK5000, User information, Allen fastening screws M3 x 14 mm ISO 4762, lock washers M3 DIN 7980, strain relief for sensor cable, distance gage 0.8 mm

Additional information:

Short Description, Technical Details
Product Overview

Page 136 cont.
Page 4 cont.

5.4

5.5



5.0 MagLine Product Overview	3
5.1 MagLine Micro	12
5.2 MagLine Basic	44
5.3 MagLine Macro	110
5.4 MagLine Roto	134

5.5 | Accessories

Products	Programming tool PTM	170
	Mating connectors	171
	Cable extensions	172
	Cover rail PS1	177
	Profile rail PS	178
	Protective strip	179
	Profile rail PSA	180

5.6 Appendix	182
5.7 Product index, Contact information	188

5.0

5.1

5.2

5.3

5.4

5.5

5.6

5.7

Profile

- Easy handling
- No additional accessories required
- Battery operation with 9 V block battery
- For programming MA508: LC display mode, resolution, decimal point position, counting direction, reset delay

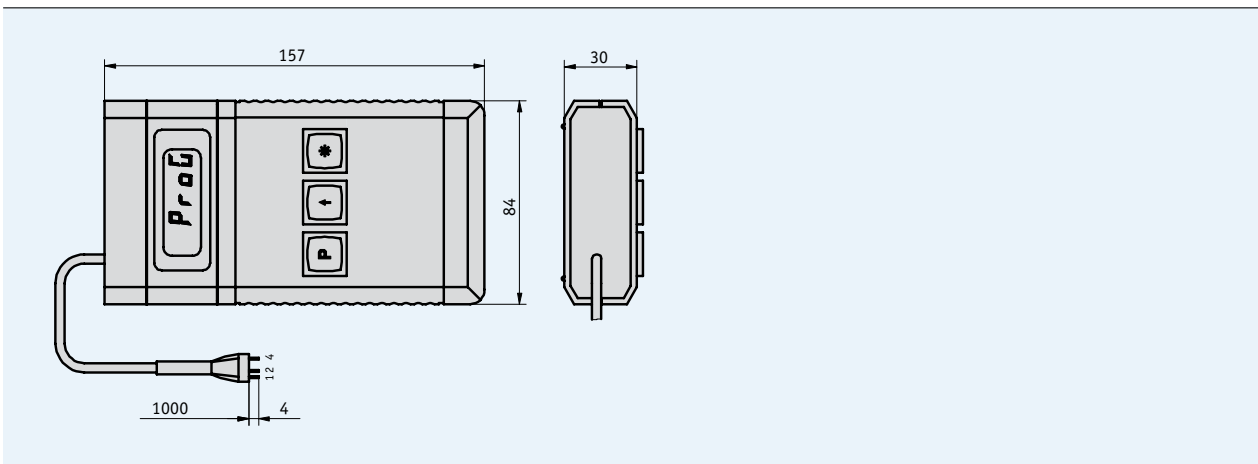

5.5

Mechanical data

Technical data		Additional information
Supply	9 V block battery	exchangeable with standard connector, reverse-polarity protection
Display	7 segments, 4-digit	digit height 9 mm
Temperature range	0 ... +50 °C	

Pin assignment

Signal	PIN
CLK	1
DATA	2
GND	3

Order

- Order code

PTM

Scope of delivery: PTM, Benutzerinformationen

Profile

- Mating connectors, straight
- Mating connectors, offset

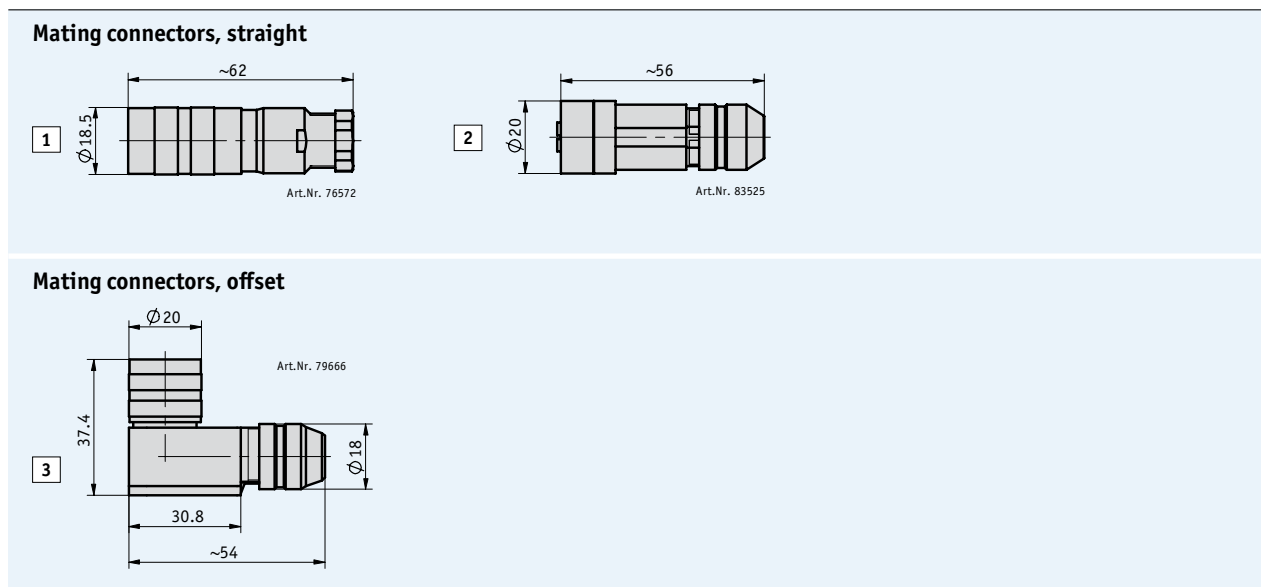

5.5

	Sensors
	MSA510/1 MSA511

	Pict.	PIN	Cable Ø	Order data		
Mating connectors, straight						
Encoder	1	12	6 ... 8	76572		•
Encoder	2	8	6 ... 8	83525	•	
Mating connectors, offset						
Encoder	3	12	6 ... 8	79666		•

Order

- Order code (see Product Matrix)

Scope of delivery: Mating connector

Accessories MagLine

■ Matrix for cable extension

Cable extensions are offered for a range of sensors. For appropriate pin assignments, refer to the data sheets of the individual cable extensions (see matrix).

			Sensors			
			AEA111/1	MSA111	MSA510/1	MSA511
Page	Cable sheath	Products				
Cable extension						
173	PUR	KV08S2			•	
174	PUR	KV12S0				•
175	PUR	KV18S0	•	•		
176	PUR	KV18S1	•	•		

Profile

- Ready-to-use cable connection
- Cable lengths up to 20 m



Type of connection GE

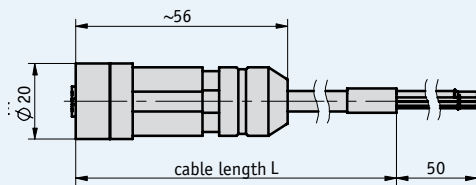

Mechanical data

Feature	Technical data	Additional information
Cable sheath	PUR	
Temperature range	-30 ... +100 °C	

5.5

Pin assignment

KV08S2

Cable color	PIN
white	1
brown	2
green	3
yellow	4

Cable color	PIN
gray	5
pink	6
blue	7
red	8

Order

Order table

Feature	Order text	Specification	Additional information
Cable length	...	1 ... 20 m, in steps of 1 m	

Order code

KV08S2 - GE -

Scope of delivery: KV08S2, User information

Profile

- Ready-to-use cable connection
- Cable lengths up to 20 m

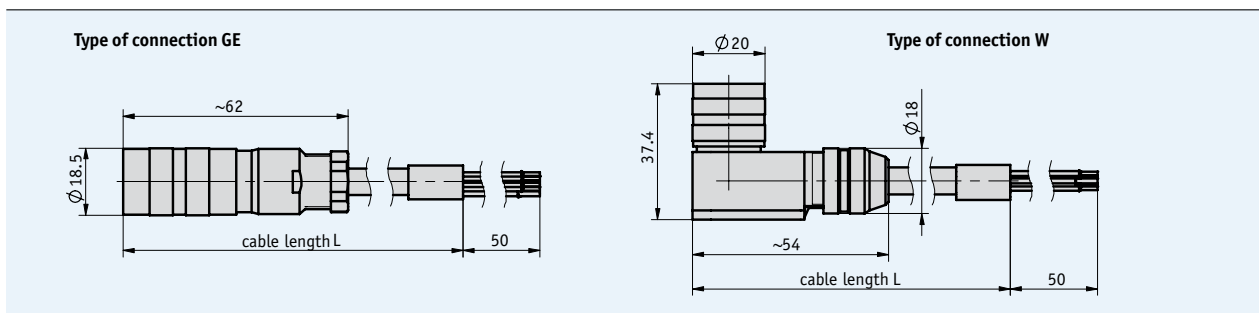

Mechanical data

Feature	Technical data	Additional information
Cable sheath	PUR	
Temperature range	-30 ... +100 °C	

Pin assignment

KV12S0

Cable color	PIN
blue	A
violet	B
green	C
red	D
yellow	E
pink	F

Cable color	PIN
red-blue	G
white	H
gray-pink	J
gray-pink	K
black	L
brown	M

Order

Order table

Feature	Order text	Specification	Additional information
Type of connection	GE W	straight connector angle connector	
Cable length	... B	1 ... 20 m, in steps of 1 m	

Order code

KV12S0 - -

Scope of delivery: KV12S0, User information

Profile

- Ready-to-use cable connection
- Cable lengths up to 20 m



Type of connection GE

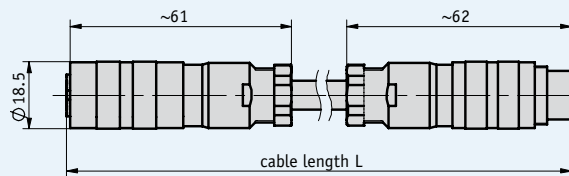

Mechanical data

Feature	Technical data	Additional information
Cable sheath	PUR	
Temperature range	-30 ... +100 °C	

5.5

Pin assignment

■ KV18S0

Cable color	PIN
white-blue	A
white-yellow	B
yellow-brown	C
white-green	D
brown-green	E
red-blue	F
gray-pink	G
violet	H
black	I

Cable color	PIN
gray-brown	K
white	L
brown	M
red	N
gray	O
pink	P
yellow	R
green	S
blue	T
screen	U

Order

■ Order table

Feature	Order text	Specification	Additional information
Cable length	...	A 1 ... 20 m, in steps of 1 m	

■ Order code

KV18S0 - GE/GE -

Scope of delivery: KV18S1, User information

Profile

- Ready-to-use cable connection
- Cable lengths up to 20 m



Type of connection GE/GE

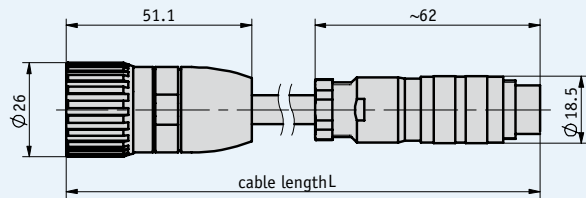

Mechanical data

Feature	Technical data	Additional information
Cable sheath	PUR	
Temperature range	-30 ... +100 °C	

Pin assignment

KV18S1

Cable color	PIN
white-blue	A/1
white-yellow	B/2
yellow-brown	C/3
white-green	D/4
brown-green	E/5
red-blue	F/6
gray-pink	G/7
violet	H/8
black	I/9

Cable color	PIN
gray-brown	K/10
white	L/11
brown	M/12
red	N/13
gray	O/14
pink	P/15
yellow	R/16
green	S/17
blue	T/18
screen	U/19

Order

Order table

Feature	Order text	Specification	Additional information
Cable length	...	1 ... 20 m, in steps of 1 m	

Order code

KV18S1 - GE/GE -

Scope of delivery: KV18S1, User information

Profile

- Aluminum cover for mechanical protection of magnetic strips with widths up to 10 mm (except MB100 and MBA111)
- Easy mounting owing to the V-notch for drilling holes

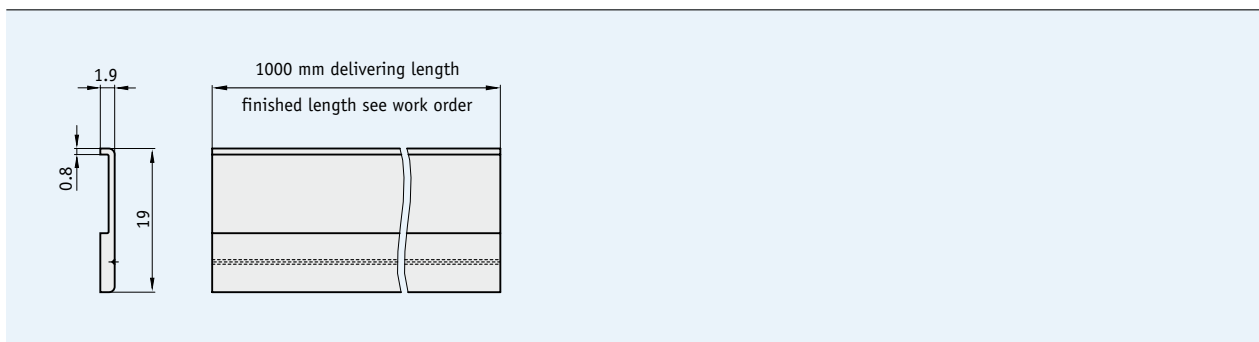

Mechanical data

Feature	Technical data	Additional information
Material	aluminum	

5.5

Order

- Order code

PS1 - 1.0

Scope of delivery: PS1

Profile

- Robust mounting unit for magnetic bands with 10 mm width
- No adhesive joints
- Perfect accommodation for magnetic bands
- Extensible plug-in modules
- Easy mounting

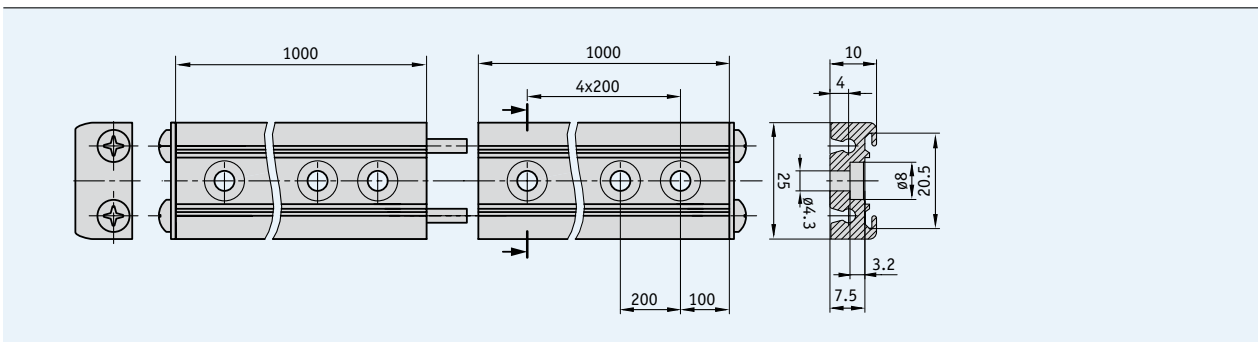

Mechanical data

Feature	Technical data	Additional information
Material	aluminum	

Order

▪ **Order table**

Feature	Order data	Specification	Ergänzungen
Length	1.0 ...	1 m 0.3 ... 10 m, in steps of 0.1 m	

▪ **Order code**

PS -

Scope of delivery: PS, coupling pins, closing panel, User information



Accessories:
Protective strip SB

Page 181

Profile

- Easy mounting
- For sliding into profile rail PS
- No adhesive joints

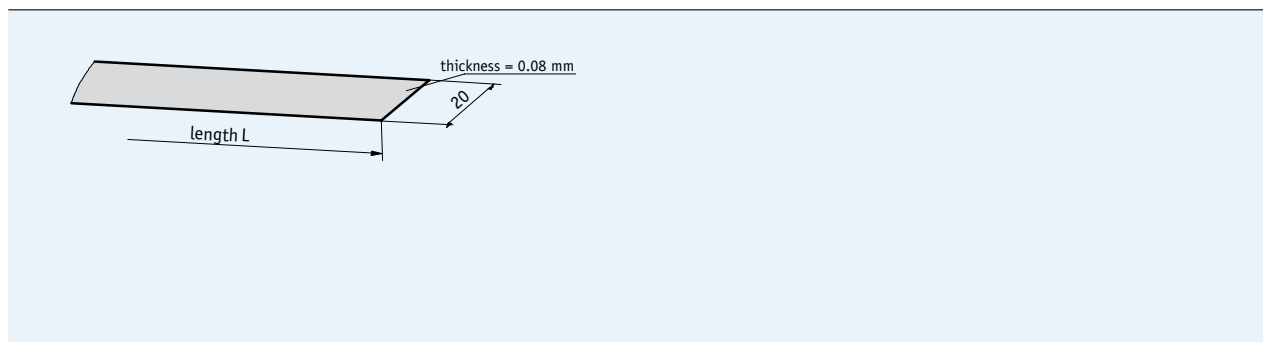

Mechanical data

Feature	Technical data	Additional information
Material	stainless steel	

5.5

Order

Order table

Feature	Order data	Specification	Ergänzungen
Length	1.0 ...	1 m 0.3 ... 10 m, in steps of 0.1 m	required length = profile rail + 36 mm

Order code

SB - 20 - - without
A

Scope of delivery: SB

Profile

- Robust mounting unit for magnetic bands with 20 mm width
- Extensible via plug-in modules
- Easy mounting

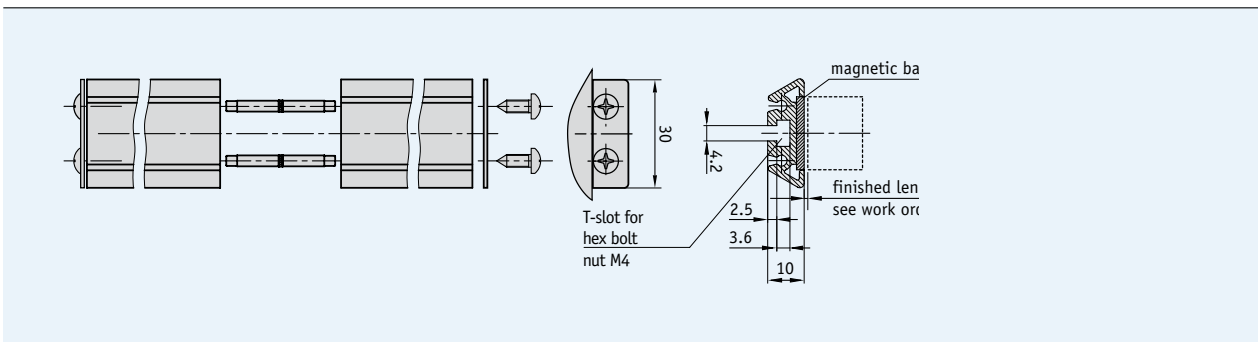

Mechanical data

Feature	Technical data	Additional information
Material	aluminum	

Order

▪ **Order table**

Feature	Order data	Specification	Ergänzungen
Length	0.5 ...	A profile rail: 0.5 m ±0.5 mm 0.15 ... 3 m, in steps of 0.15 m	

▪ **Order code**

PSA -

Scope of delivery: PS, closing unit, connection parts

5.6



Länge

5.0 MagLine Product Overview	3
5.1 MagLine Micro	12
5.2 MagLine Basic	44
5.3 MagLine Macro	110
5.4 MagLine Roto	134
5.5 Accessories	168

5.6 | Appendix

Measuring curves sensor/band	184
Specifications of magnetic bands	185
Resolution, pulse interval, travel speed, counting frequency	186

5.7 Product index, Contact information	188
--	-----

5.0

5.1

5.2

5.3

5.4

5.5

5.6

5.7

Accuracy comparison (MB100, MB500)

The diagrams opposite show typical measurement curves. Measurement is based on combinations of magnetic band and the corresponding sensor.

Picture 1 (MagLine Micro)

- MB100 (10 μ)
- MSK1000
- Increment 1.1 mm, measuring length 1000 mm

Picture 2 (MagLine Micro)

- MB100 (50 μ)
- MSK1000
- Increment 1.1 mm, measuring length 1000 mm

Picture 3 (MagLine Basic)

- MB500 (100 μ)
- MSK5000
- Increment 5.1 mm, measuring length 1900 mm

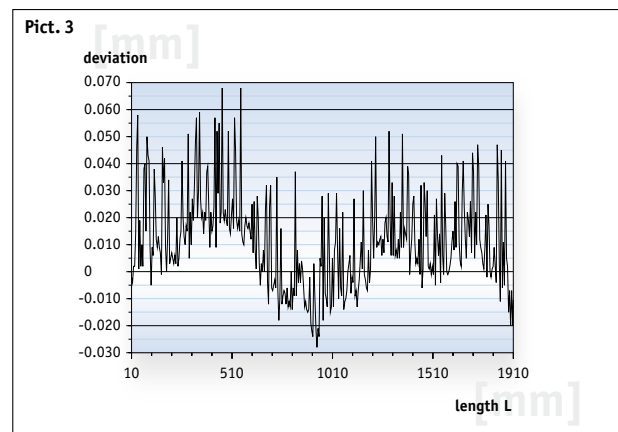
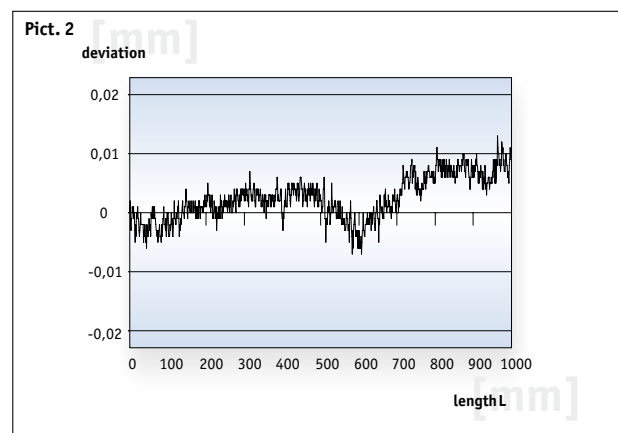
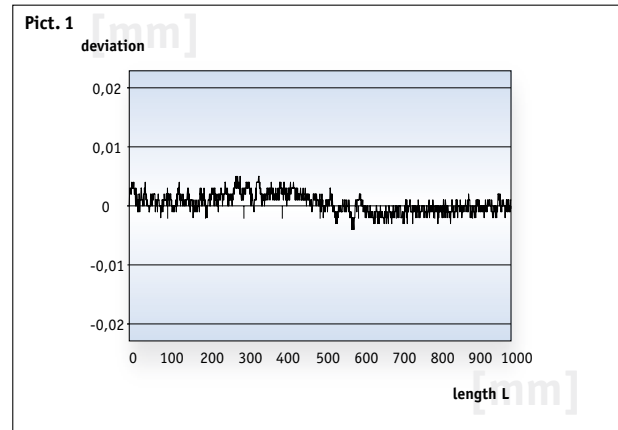

Technical data

Mechanical data

Dimensions	see data sheets	MB100, MB200, MB320, MB400, MB500, MB2000, MBA, MBA511, MBA111, MBA1000, MB4000
Bend radius	>50 mm	
Available length	max. 90 m	

Band/strip materials

Carrier strip	spring steel	
	VA (stainless steel strip)	
Magnet material	plastic-bonded ferrite	
Cover strip	stainless steel	

Environmental conditions

Operating temperature	-40 ... +80 °C	option: -40 ... +120 °C
Storage temperature	-40 ... +80 °C	

Resistance to chemicals, dirt, and liquids (qualitative allocation)

high	medium	low (can be enhanced by additional protective measures)
water/water vapor	acetone	xylo/toluol
formic acid	stearic acid 70 °C, anhydrous	trichlorethylene
formaldehyde, 40 %,	oleic acid	tetrahydrofuran
glycerin 98 °C	diisopropyl ether	tetrachloromethane
N-hexane	acetic acid	turpentine
iso-octane	benzine	nitric acid
lactic acid	kerosene	nitrobenzene
mineral oil	ammonia	lacquer solvent
linseed oil	acetylene	benzene
cotton seed oil	seawater	aromatic hydrocarbons
plant oils		ketones
wood dust/chips		anorganic acids (HCL, H ₂ SO ₄)
stone dust		drilling emulsions
metal dust/chips		

Field strength (typical values, measured on the band surface with hall-effect probe)

MB100	30 kA/m	
MB200	28 kA/m	
MB320	40 kA/m	
MB400	38 kA/m	
MB500	36 kA/m	

Accuracy data

	Accuracy classes	
MB100	10 µm	
	50 µm	
MB200	50 µm	
	100 µm	
MB320	100 µm	
	1 mm	
MB400	50 µm	
	100 µm	
MB500	1 mm	
	1 mm	
MB2000	1 mm	
MB4000	1 mm	
MBA111	10 µm	
MBA	50 µm	
MBA511	100 µm	
MBA1000	1 mm	

Expansion coefficients

spring steel	11 µm/K
VA carrier	16 µm/K

Typical accuracy curves

MB100	10 µm	Picture 1
	50 µm	Picture 2
MB500	100 µm	Picture 3

Relation between resolutions and pulse interval

The resolution and pulse interval parameters can be selected on the sensors of MSK range. The interfaces of these sensors supply digital output signals (counting pulses), which can be processed in a higher-level controller with a counter input.

Definition: Pulse interval

The pulse interval “t” is the smallest period of time between two edges which can occur during sensor motion. Micro-vibrations can also act as triggers.

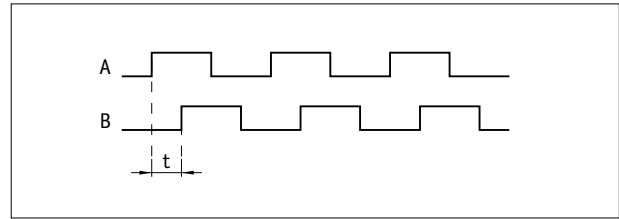

The calculation formula

Resolution and pulse intervals must be coordinated with the maximum possible counting frequency of the controller. With the **maximum travel speed** of the system, the **counting frequency** of the follow-up electronic system can be determined with the gray highlighted formulas. An example calculation with these formulas is shown below.

$$\text{Pulse interval} = \frac{\text{resolution}}{\text{max. travel speed}} \times 0.8$$

$$\text{Counting frequency} = \frac{1}{\text{pulse interval} \times 4}$$

Calculation example

A path should be measured with a resolution of 0.025 mm. The maximum traversing speed is 15 m/s; the pulse interval and counting frequency must be determined. The values for these calculation examples are shown in the table below (highlighted in blue).

1. Determining the pulse interval:

The next lower, programmable value is selected, in this case **1 μs**.

$$\text{Pulse interval} = \frac{0.025 \text{ mm}}{15 \text{ m/s}} \times 0.8 = 1.33 \mu\text{s}$$

2. Determining the counting frequency of the follow-up electronic system:

The downstream electronics unit must be able to recognize a frequency of **250 kHz** at the input.

$$\text{Counting frequency} = \frac{1}{1 \mu\text{s} \times 4} = 250 \text{ kHz}$$

Table for MSK5000 (example)

Resolution (mm)	Travel speed V_{max} (m/s)								
0.001	0.01	0.03	0.05	0.10	0.20	0.32	0.80	1.60	4.00
0.005	0.06	0.13	0.25	0.50	1.00	1.60	4.00	8.00	20.00
0.010	0.12	0.25	0.50	1.00	2.00	3.20	8.00	16.00	25.00
0.025	0.30	0.63	1.25	2.50	5.00	8.00	20.00	25.00	25.00
0.050	0.61	1.25	2.50	5.00	10.00	16.00	25.00	25.00	25.00
0.100	1.21	2.50	5.00	10.00	20.00	25.00	25.00	25.00	25.00
Pulse interval (μs)	66.00	32.00	16.00	8.00	4.00	2.50	1.00	0.50	0.20
Counting frequency (kHz)	3.79	7.81	15.63	31.25	62.50	100.00	250.00	500.00	1250.00

5.7



5.0 MagLine Product Overview	3
5.1 MagLine Micro	12
5.2 MagLine Basic	44
5.3 MagLine Macro	110
5.4 MagLine Roto	134
5.5 Accessories	168
5.6 Appendix	182

5.7 Product index, Contact information	190
---	------------

5.0

5.1

5.2

5.3

5.4

5.5

5.6

5.7

MagLine Micro, MagLine Basic, MagLine Macro,
and MagLine Roto

PTM

MSK320

Gerät	Typ	Page
A		
AEA	Translation module, absolute	88
AEA111/1	Translation module, absolute	41
AS510/1	Translation module, incremental	72
ASA510	Translation module, quasi-absolute	108
G		
	Mating connectors	171
K		
KV08S2	Cable extension	173
KV12S0	Cable extension	174
KV18S0	Cable extension	175
KV18S1	Cable extension	176
L		
LE100/1	Magnetic sensor, incremental	26, 154
LS100	Magnetic sensor, incremental	29
M		
MA100/2	Magnetic display	34
MA501	Magnetic display with sensor	90
MA502	Magnetic display	66
MA503/1	Magnetic display with sensor	93
MA503/WL	Magnetic display with sensor	96
MA504	Magnetic display with sensor	101
MA505	Magnetic display	84
MA506	Magnetic display	70
MA508	Magnetic display with sensor	104
MA561	Magnetic display	86
MA564	Magnetic display with sensor	106
MB100	Magnetic band, incremental	16
MB200	Magnetic band, incremental	50
MB320	Magnetic band, incremental	52
MB400	Magnetic band, incremental	114
MB500	Magnetic band, incremental	54
MB2000	Magnetic band, incremental	116
MB4000	Magnetic band, incremental	118
MBA	Magnetic band, absolute	74
MBA111	Magnetic band, absolute	36
MBA511	Magnetic band, absolute	76
MBA1000	Magnetic band, absolute	129

Gerät	Typ	Page
MBR100	Magnetic ring, incremental	146
MBR200	Magnetic ring, incremental	148
MBR320	Magnetic ring, incremental	150
MBR500	Magnetic ring, incremental	152
MR200	Magnetic ring, incremental	138
MR320	Magnetic ring, incremental	140
MR500	Magnetic ring, incremental	142
MRI01	Magnetic ring, incremental	144
MS100/1	Magnetic sensor, incremental	32
MS500	Magnetic sensor, incremental	66
MSA	Magnetic sensor, absolute	78
MSA111	Magnetic sensor, absolute	38
MSA510/1	Magnetic sensor, absolute	80
MSA511	Magnetic sensor, absolute	82
MSA1000	Magnetic sensor, absolute	131
MSK210	Magnetic sensor, incremental	56, 157
MSK320	Magnetic sensor, incremental	59, 160
MSK400/1	Magnetic sensor, incremental	120
MSK1000	Magnetic sensor, incremental	18
MSK1100	Magnetic sensor, incremental	22
MSK2000	Magnetic sensor, incremental	123
MSK4000	Magnetic sensor, incremental	126
MSK5000	Magnetic sensor, incremental	62, 163
P		
PTM	Programming tool	170
PS	Profile rail	178
PS1	Cover rail	177
PSA	Profile rail	180
R		
RTX500	Radio module	99
S		
SB	Protective strip	179

MBA

LS100

5.7

Germany

A dealer near you? Our website will help you.

Just enter your postal code at www.siko.de/en/contact/germany and you will find the current contact data of the representative in your area. Or give us a call and we will be pleased to pass on the contact data.

International

SIKO is represented by our subsidiaries and trade partners all over the world: www.siko.de/en/contact/international

Africa

Republic of South Africa

Asia

China
Indonesia
Israel
Japan
Malaysia
Republic of Korea
Singapore
Taiwan
Thailand
Vietnam

Australia

Australia
New Zealand

Europe

Austria
Belgium
Croatia
Czech Republic
Denmark
Finland
France
Greece
Hungary
Italy
Lithuania
Luxembourg
Netherlands
Norway
Poland
Portugal
Russian Federation
Serbia and Montenegro
Slovakia
Slovenia
Spain
Sweden
Switzerland
Turkey
Ukraine
United Kingdom

America

Brazil
Canada
Mexico
United States





SIKO GmbH
Weihermattenweg 2
D-79256 Buchenbach

Telephone
+49 7661 394-0

Telefax
+49 7661 394-388

E-Mail
info@siko.de

Internet
www.siko.de

