

**FREE RETURN SHIPPING
ON SHARPENING ORDERS**

SEE BACK COVER OR
PAGE 76 FOR DETAILS

EXPRESS SERVICE

Custom Manufactured Router Bits
Shaper Cutters • Moulding Knives
2-3 Day Delivery • Call for Details!

**AMERICA'S
★ BEST ★ S**

RIDGE CARBIDE TOOL CO.

**SAW BLADES
ROUTER BITS • CUTTERS**



**LIBERTY LINE
ROUTER BITS
RATED EXCELLENT BY
FINE WOODWORKING
MAGAZINE**

**TS2000
SAW BLADES RATED
NO. 1 BY
AMERICAN WOODWORKER
MAGAZINE**

**RS1000
MITRE BLADE RATED
NO. 1 BY
FINE WOODWORKING
MAGAZINE**

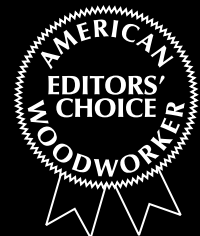

MASTER CATALOG

CARBIDE TIPPED SAW BLADES • ROUTER BITS • SHAPER CUTTERS • KNIVES

CALL TOLL FREE: 1-800-443-0992 • TOLL FREE FAX: 1-888-728-8665

VISIT OUR WEB SITE AT WWW.RIDGECARBIDETOOL.COM



Custom Tooling - Factory Direct

TOLL FREE FAX (888) 728-8665

RCT can manufacture custom made-to-order router bits, shaper cutters and profile knives for your special jobs and restoration projects. Use this handy form for a free price quote.

We are not responsible for verbal instructions.

Customer Information

Company Name: _____
 Contact: _____
 Address: _____

 City: _____
 State: _____ Zip Code: _____
 Phone Number: _____
 Fax Number: _____

Send Wood Samples
 or Drawings to:
Ridge Carbide Tool Co.
 P.O. Box 497
 595 New York Ave.
 Lyndhurst, NJ 07071

Standard 2 Week Delivery Quote Express 2-3 Day Delivery Quote

Drawing Examples

Router Bit
 Rotation:
 CW
 Tool is in
 relation to
 the material.

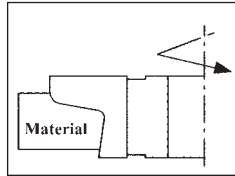
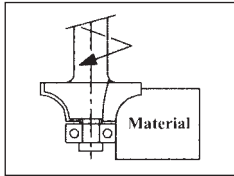

Tool Rotation:
 CCW
 Tool is in
 relation to
 the material.

For Custom Profile Knives See Chart Page 62

1/8" Squares

Actual-size Drawings Only (1 to 1 Scale)

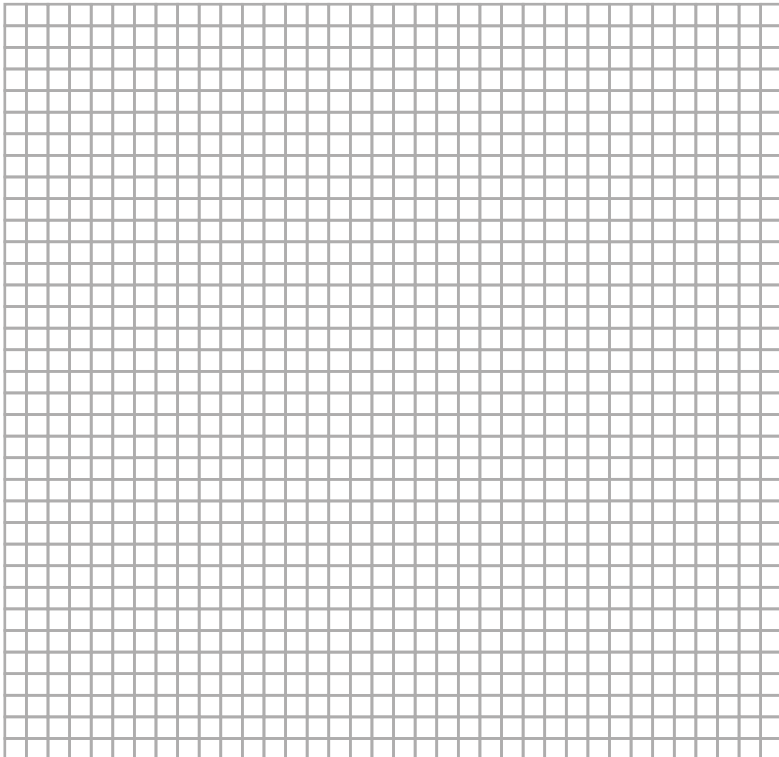

Signature: _____ Date: _____

Machine Information

Type of Machine: _____
 Collet/Spindle Size: _____
 Keyway: Yes No Quantity: _____ Size: _____
 RPM: _____
 Feed Rate: _____
 Minimum Circle: _____
 Maximum Circle: _____
 Comments: _____

Tool Information

Type of Tool: _____
 Tip Preference: Carbide RCT-Alloy
 Bore/Shank Size: _____
 Number of Wings:
 Two Three Four Other _____
 Rotation:
 Clockwise Counterclockwise
 If Moulder:
 Top Head Bottom Head
 Left Head Right Head
 Feed Direction:
 With Grain Against Grain
 Both
 Optional: Tool Diameter: _____
 Comments: _____

Material Information

Type of Material Being Cut: _____

 Thickness of Material: _____
 Position of Material:
 Face-Up Face-Down
 Comments: _____

Profile Information

Wood Sample
 Scale Drawing Showing Material
 Fax Drawing
 CAD File (.DXF or .DWG format)
 Comments: _____

• PROFILE ROUTER BITS • CNC ROUTER BITS

• CORRUGATED BACK KNIVES • MOLDER PLANNER KNIVES • GROOVERS & CUTTERS

• PROFILE SHAPER CUTTERS • WILLIAM & HUSSEY AND SHOP FOX PROFILE KNIVES •

EXPRESS 2-3 DAY DELIVERY

CUSTOM MADE
ROUTER BITS • SHAPER CUTTERS • PROFILE SHAPER KNIVES



"WE DELIVER WHAT OTHER'S ONLY PROMISE."

When you need custom made router bits and cutters super fast Ridge Carbide Tool has changed the way people think about what express service really is.

Anyone can ship over night after taking weeks to make your tool. But only Ridge Carbide can build your custom tools practically overnight. So you'll have them faster than ever before. And just like any other one of our products of 35 years, your 100% satisfaction is always guaranteed.

So the next time you need a custom cutter fast, call Ridge Carbide Tool and get it super fast.... ***Not Half Fast.***

***Full Quality Sharpening Service - Quick 2 Day Turnaround
Free Return Shipping
See Back Cover For Info***

RIDGE CARBIDE TOOL COMPANY

595 NEW YORK AVE. • P.O. BOX 497 • LYNDBURST, NJ 07071

CALL US TOLL FREE 1-800-443-0992

FOR FAST QUOTES FAX DRAWINGS

TOLL FREE 1-888-728-8665 or EMAIL TO: rcttool@verizon.net



www.ridgecarbide.com
www.ridgeblades.com

TABLE OF CONTENTS

ACCESSORIES	PAGE
ADAPTORS	22
ARBORS	22
BEARINGS	22
LOCK COLLARS	22
CARBIDE ROUTER BITS	
BEEGING	16
BEVEL	12, 13
BULL NOSE	17
CABINET DOOR BIT SETS	35
CHAMPHER	19, 29
CLASSICAL	18
COMBO BEVEL	12
COMPRESSION	12
CONESTOGA DOOR EDGE	26
COPE & STICK SETS	33, 36
CORE BOX/ROUND NOSE	17
COVE	18
CUSTOM MADE BIT FORM	INSIDE COVER
DADO CLEAN OUT	13
DISH CUTTING	20
DOOR EDGE	30
DOUBLE EDGE EASING	28
DOVE TAIL	20
DROP LEAF	18
EDGE BEAD	17
EDGE FORMING	23-27
FINGER JOINT	31
FLOORING	29
FLUSH PILOT PANEL	12
FLUSH TRIM	14
GLUE-WELL FLUSH TRIM	13
GLUE JOINT	13
HAND RAIL - 6010	32
LOCK MITRE	31
MICA FILE - LAMINATE	13
MORTISING	11, 16
OGEE	19
OVERHANG	14
PATTERN - TEMPLET	14
RABBET	15
RAISED PANEL	36, 37
REVERSIBLE PROFILE	32
ROMAN OGEE	19
ROUND BOTTOM VEINING	15
ROUND OVER	16
ROUND OVER - PLUNGE	16, 28
ROUND OVER - POINTED	16
SHORTENED HALF ROUND	28
SLOT CUTTERS	21
SPIRAL	12
SOLID SURFACE	23-26
SPLINE CUTTERS	13
STAGGER TOOTH	11
STRAIGHT - PLUNGE	11, 15
TRADITIONAL	17, 20
TONGUE & GROOVE	29
V-GROOVE	15, 20
V-PANEL T&G	30
WAVY	18
WINDOW SASH	30
WINDOW SILL	27

DRILLING TOOLS	
FORSTNER	74
METRIC BORING BITS	75

SAW BLADES - DADO SETS - GROOVERS	
AWARD WINNING WOODWORKING BLADES	
BAND SAW BLADES	38
TS2000 COMBINATION TABLE SAW BLADE	4
RS1000 RADIAL CHOP & MITRE SAW BLADE	4
ALUMINUM	7
COMBINATION	4, 7
CORIAN - SOLID SURFACE	7
CUT OFF	6
DADO SETS	5
GROOVERS	10
LAMELLO (BISCUIT) BLADES	10
MELAMINE BLADES	6
MITRE BLADES	4
PLASTIC BLADES	9
RADIAL OVERARM BLADES	4
RIP BLADES	7
SAW BLADE SHARPENING	BACK COVER
SCORING SAW - SPLIT	8
SLIDING TABLE SAW BLADE	8
THIN LINE BLADES	9
THIN RIM PLASTIC BLADES	9
VENEER BLADES	6
VERTICAL PANEL BLADES	8

CARBIDE SHAPER CUTTERS	
ANGLE	41
CONVEX RADIUS (FLUTE)	39, 74
CONCAVE RADIUS (BULL NOSE)	39
CUSTOM MADE	
TO ORDER CUTTERS	INSIDE COVER

CARBIDE SHAPER CUTTERS (con't)	
COPE & STICK -	
CABINET DOOR SETS	43, 44
INTERIOR DOOR SETS	45, 46
EXTERIOR DOOR SETS	46, 47
DOOR EDGE DETAIL	51, 53
DOUBLE EDGE EASING -	
SINGLE CUTTER	40
2 PC. ADJUSTABLE SET	40
FLOORING	42
FLUTE	39
GLUE JOINT	54
HALF ROUND - SHORTENED	40
HAND RAIL (6010)	55
LOCK MITRE	54
MAJIC MOLDER	56-61
RAISED PANEL	49, 50
REVERSIBLE MATCHED DETAIL	55
STRAIGHT	40
TONGUE & GROOVE	42
V-PANEL T&G	42

KNIVES AND HEADS	
CORRUGATED BACK -	
CUSTOM PROFILE CHART	62
STOCK PROFILE KNIVES	62-68
HEADS	62
JOINTER/PLANER	69-73
MAJIC MOLDER - HEAD	56
MAGIC - PLUG CUTTERS	57-61
WILLIAM & HUSSEY -	
CUSTOM PROFILE CHART	62
STOCK PROFILE KNIVES	62-68
NOTE: ALL WILLIAM & HUSSEY KNIVES WILL ALSO WORK ON THE NEW SHOP FOX MACHINE.	



CUSTOM ORDER & RETURN POLICY

- FULL PAYMENT IN ADVANCE.
- CUSTOM TOOLS ARE NOT RETURNABLE.
- CUSTOM TOOLS CANNOT BE CANCELLED.
- 15% RESTOCKING CHARGE ON STANDARD TOOL RETURNS, PLUS RECONDITIONING CHARGE IF NEEDED.
- THIS CATALOG SUPERSEDES ALL PREVIOUS EDITIONS. PRICES SUBJECT TO CHANGE WITHOUT NOTICE. WE ARE NOT LIABLE FOR TYPOGRAPHICAL ERRORS.

**100% QUALITY & SATISFACTION GUARANTEE
ALL RIDGE CARBIDE TOOL PRODUCTS CARRY
A 90 DAYS UNCONDITIONAL GUARANTEE.**

PUT VERY SIMPLY, IF YOU ARE NOT COMPLETELY SATISFIED WITH OUR PRODUCT AFTER 90 DAYS YOU MAY RETURN IT FOR REFUND OR REPLACEMENT.

THIS GUARANTEE DOES NOT APPLY TO INFERIOR PERFORMANCE CAUSED DIRECTLY OR INDIRECTLY BY MISUSE, ABUSE, NEGLIGENCE OR ALTERATION TO TOOL OR TO IMPROPER SHARPENING.

PRICES AND SHIPPING CHARGES SUBJECT TO CHANGE WITHOUT NOTICE.

RIDGE CARBIDE TOOL COMPANY.

REAL TOOLS. REAL SOLUTIONS. EXTRAORDINARY SERVICE.

When it comes to Carbide Cutting Tools, our reputation precedes us. That's why so many other tool companies recommend us for our vast experience in carbide cutting tools.

We'd like to thank you for requesting our latest catalog. This catalog not only offers the most complete line of the finest carbide tipped and high-speed steel wood-cutting products in America, it also contains some tools that have been nationally recognized as being among the best in the industry.

The Award Winning, 100% American Made TS2000 Table Saw Blade.

Rated "Excellent" by Fine Woodworking Magazine and recipient of the "Editor's Choice" award from American Woodworker Magazine. We're proud to have been recognized by these two fine industry publications.



Take a close look at our North Woods 4-tooth chipper Dado-Master. Priced at \$100.00 less than the best known Dado, we'll confidently go cut for cut against any competition. Our Dado-Master offers both the hobbieist and the professional outstanding quality and tremendous savings. The Dado-Master is geared to all your production needs and is available in either a 6", 8" or 10" diameter.

Liberty Line Router Bits, 100% American Made.

Talk to us about all of your carbide tipped, jointer planer knives, solid carbide and HSS knife needs. We can also custom manufacture HSS profile knives for the new jointer planer machines and Williams and Hussy's on the market.

The Ridge Carbide Difference.

We are a real tool company. We are not just tools from a catalog. We're also here to help you. If you don't see the tool you're looking for in our catalog, we can make it for you. We carry a wider range of unique bits and cutters than other catalogs and we'll even help you find tools you're looking for. We can sharpen and repair any tool in our catalog or any other tools you may need sharpened.

There aren't many other mail-order catalogs that can make these claims. Think of Ridge Carbide as your *Comfort Zone* where top quality products and service are built into the way we do business.



AWARD WINNING SAW BLADES



Wood Magazine, February 2000 "Ridge Carbide's TS2000 come close to the edge quality of a Forrest blade but has more side clearance so it is less likely to burn your material than the Forrest."

THE SAW BLADE TESTS ARE IN!

Here's Your Chance To Own A Ridge Carbide Award Winning Blade!

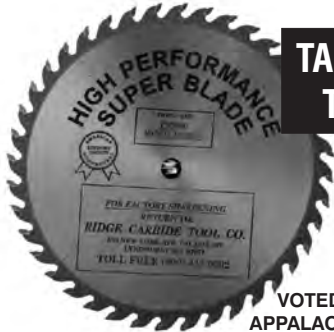

TABLE SAW BLADE TS2000 SERIES

America's Smoothest
Cutting Top Rated
Woodworking Table
Saw Blade

VOTED BEST PRODUCT AT THE
APPALACHIAN HARDWOOD EXPO '95

Order No.	Description	Kerf	Bore	Price
TS2640	<i>New</i> 6" x 40T	3/32"	5/8"	\$89.00
TS26540	<i>New</i> 6-1/2" x 40T	3/32"	5/8"	95.00
TS272540	7-1-1/4" x 40T	3/32"	5/8"	69.00
TS2840TK	8" x 40T	3/32"	5/8"	95.00
TS2840	8" x 40T	1/8"	5/8"	89.00
TS282540	8-1/4" x 40T	1/8"	5/8"	95.00
TS2940	9" x 40T	1/8"	5/8"	109.00
TS21024TK	<i>New</i> 10" x 24T	3/32"	5/8"	89.00
TS21040	10" x 40T	1/8"	5/8"	104.00
TS21040TK	10" x 40T	3/32"	5/8"	104.00
UTS21048AF	<i>New</i> 10" x 48T	1/8"	5/8"	115.00

25 DEGREE ATB WITH 5 DEGREE ALT. FACE BEVELS

THE ULTIMATE TABLE SAW BLADE FOR TODAY'S SERIOUS WOODWORKER
CUTS SOFT & HARDWOOD SUPER SMOOTH
CROSSCUTS PLYWOOD BETTER THAN A 100 TOOTH BLADE

TS2124858	<i>New</i> 12" x 48T	1/8"	5/8"	135.00
TS21240	12" x 40T	1/8"	1"	125.00
TS21440	14" x 40T	5/32"	1"	145.00
TS21640	<i>New</i> 16" x 40T	5/32"	1"	165.00

ADD \$19.00 FOR BORE SIZE OTHER THAN LISTED

CUSTOM SIZE BLADES MADE TO ORDER CALL FOR PRICE

FULL ORIGINAL FACTORY SHARPENING SERVICE ON OUR BLADES
AND ALL OTHER BRANDS OF CARBIDE BLADES.

Super Table Saw Blades Hi Performance TS2000 & RS 1000

- C-4 Micro-Grain carbide tips 1/3 larger than the best known blades
- Rips and crosscuts hard and soft wood, smooth as a baby's bottom
- No bottom splintering on plywood veneers
- Carbide teeth are ground to a 600 grit micro finish for razor sharpness
- 20-25 blade sharpenings possible

Only Ridge Carbide Tool Company's Super Saw Blades TS2000 and RS1000 woodworking blades are Guaranteed to cut super smooth, swirl free cutting without stabilizers for its usable life.



MITER SAW BLADE RS1000 SERIES

ALSO FOR RADIAL SAWS &
COMPOUND MITER SAWS

#1 Top Rated Blade
In America by
Fine Home Building

Order No.	Description	Kerf	Bore	Price
<i>New</i> RS116048	FESTOOL 160MM x 48T	3/32"	20MM	\$90.00
RS172560	7-1/4" x 60T	3/32"	5/8"	85.00
RS1860	8" x 60T	1/8"	5/8"	105.00
RS182560	8-1/4" x 60T	1/8"	5/8"	105.00
RS18560	8-1/2" x 60T	3/32"	5/8"	109.00
RS1960	9" x 60T	1/8"	5/8"	109.00
RS11060	10" x 60T	1/8"	5/8"	119.00
RS11080	10" x 80T	1/8"	5/8"	129.00
<i>New</i> URS11080AF	NEW ULTRA 5 DEG. ALT. FACE BEVEL - 25 DEG. ATB ULTRA MITER BLADE 10" x 80T	1/8"	5/8"	135.00
RS1126058	12" x 60T	1/8"	5/8"	135.00
RS11260	12" x 60T	1/8"	1"	135.00
RS1128058	12" x 80T	1/8"	5/8"	145.00
RS1280	12" x 80T	1/8"	1"	139.00
<i>New</i> URS11280AF	NEW ULTRA 5 DEG. ALT. FACE BEVEL - 25 DEG. ATB ULTRA MITER BLADE 12" x 80T	1/8"	1"	159.00
RS11460	14" x 60T	5/32"	1"	165.00

ADD \$19.00 FOR BORE SIZE OTHER THAN LISTED

100% SATISFACTION
OR YOUR MONEY BACK!

TS2000 Rated Excellent by Fine Woodworking
In all 5 tests and had the least plate runout.
October 1996 Issue, Page 42 & 43

FWW-TEST	FWW-RATING
PLATE RUNOUT	.003/LEAST
PLYWOOD CROSSCUT	EXCELLENT
MELAMINE	EXCELLENT
MDF	EXCELLENT
OAK (RIP)	EXCELLENT



ONCE AGAIN, THE RIDGE CARBIDE COMBO BLADE IS RECOGNIZED.

Fine Woodworking magazine reviewed and tested thirty saw-blades. We're proud to say that our TS-2000 combo blade was rated excellent in all areas. We even ran truer than the most popular blade on the market. Today we feel honored once again. Our TS-2000 combo blade isn't only the choice of many seasoned woodworkers, it's the Editor's Choice, given to us by American Woodworker magazine. And after being put to the test again, against eighteen competitors, we wear this honor proudly. (See AW issue #65, page 66, April 1998).



CALL TOLL FREE 1-800-443-0992 • FAX TOLL FREE 1-888-728-8665
or visit our web site at www.ridgecarbide.com



VERY FINE CUTTING DADO SETS



RCT'S NORTHWOODS 4-TOOTH CHIPPER DADO-MASTER

At Last...An Affordable Quality Dado Set!



SUPER FINE CUT!



This set also cuts undersize plywood grooves 15/32" & 23/32"

COMPLETE DADO SET PACKAGE

Set Consists Of:

- 2 Outside Dado Blades, 5° Negative Hook, with 5/8" or 1" Bore
- 4 - 1/8" x 4 Tooth Chipper
- 1 - 1/16" x 4 Tooth Chipper
- 1 - 3/32" x 4 Tooth Chipper
- **Free Shim Set** - Full Instruction Sheet
- **Free Blade Runner Storage Case** (a \$20 value)



**-Try RCT's Dado-Master-
Compare: Before you spend over \$100.00 or more on the best known set. If you are looking for the ultimate dado set, THIS IS IT!**

Our Northwoods Dado-Master will give superior tearout-free, perfect flat bottom groove dados on all hardwoods and softwoods. This superior dado set will also dado even the most fragile plywood veneers like oak ply and melamine without a splinter or chip, and will cut in all directions.

Order No.	Dia.	Teeth/Bore	Price
NW6-DM-DS	6	16 Teeth x 5/8 Bore	\$189.95
NW8-DM-DS	8	24 Teeth x 5/8 Bore	209.95
NW8-DM-DS1	8	24 Teeth x 1 Bore	219.95
NW10-DM-DS	10	24 Teeth x 5/8 Bore	239.95
NW10-DM-DS1	10	24 Teeth x 1 Bore	259.95

THIS IS AN 8 PIECE SET!
Not 6-Piece Like Other Brands
Special Bore Size Available

Seeing is Believing! 20 Different Size Dados - 1/4" to 29/32" Wide Cuts Possible!

90 DAY 100% SATISFACTION OR YOUR MONEY BACK!



RCT'S QUARTERMASTER DADO BLADE

Here Is The Dado Blade Everyone Has Asked For!

For Undersize 1/4" Plywood and Melamine Dado Cuts

Makes a PERFECT 5.7 mm wide groove - the same width as undersize Plywood and Melamine. Makes PERFECT Flat Bottom Grooves. Make the right groove in one pass for metric Plywood and Melamine. The Quarter-Master undersize is available: 8" x 24 teeth x 5.7 mm kerf x 5/8" bore.

Order No. NW824 **\$159.95**

Other bore sizes available - add \$19.00 to price.



For Drawer Bottoms



CALL TOLL FREE 1-800-443-0992 • FAX TOLL FREE 1-888-728-8665
or visit our web site at www.ridgecarbide.com



SAW BLADES



CUT OFF & TRIM SAWS

FOR HARDWOOD, SOFT WOOD, PLY WOOD, VENEER, PANEL, FLAKEBOARD, FIBERBOARD, MASONITE

CO SERIES Cutoff & Trim ATB

Order No.	Dia.	No. of Teeth	Kerf	Bore	Price
CO84002	8	40	.112	5/8	\$79.00
CO84802	8	48	.112	5/8	92.00
CO86002	8	60	.112	5/8	99.00
CO87202	8	72	.112	5/8	129.00
CO9602	9	60	.125	5/8	102.00
CO10402	10	40	.125	5/8	84.00
CO10482	10	48	.125	5/8	99.00
CO10602	10	60	.125	5/8	102.00
CO10722	10	72	.125	5/8	135.00
CO10802	10	80	.125	5/8	139.00
CO12402	12	40	.135	1	104.00
CO12482	12	48	.135	1	112.00
CO12602	12	60	.135	1	125.00
CO12722	12	72	.135	1	139.00
CO12802	12	80	.135	1	142.00
CO121002	12	100	.135	1	177.00
CO14402	14	40	.156	1	135.00
CO14602	14	60	.156	1	142.00
CO14722	14	72	.156	1	159.00
CO14802	14	80	.156	1	162.00
CO141002	14	100	.156	1	194.00
CO16402	16	40	.156	1	145.00
CO16602	16	60	.156	1	160.00
CO16722	16	72	.156	1	179.00
CO16802	16	80	.156	1	185.00
CO161002	16	100	.156	1	205.00
CO18602	18	60	.160	1	225.00
CO18802	18	80	.160	1	235.00
CO181002	18	100	.160	1	245.00
CO181202	18	120	.160	1	281.00



A.T.B. #2



T.C.G. #3

CO SERIES Cutoff & Trim TCG

Order No.	Dia.	No. of Teeth	Kerf	Bore	Price
CO84003	8	40	.112	5/8	\$81.00
CO84803	8	48	.112	5/8	94.00
CO86003	8	60	.112	5/8	101.00
CO87203	8	72	.112	5/8	131.00
CO9603	9	60	.125	5/8	104.00
CO10403	10	40	.125	5/8	86.00
CO10483	10	48	.125	5/8	101.00
CO10603	10	60	.125	5/8	104.00
CO10723	10	72	.125	5/8	137.00
CO10803	10	80	.125	5/8	141.00
CO12403	12	40	.135	1	106.00
CO12483	12	48	.135	1	114.00
CO12603	12	60	.135	1	127.00
CO12723	12	72	.135	1	141.00
CO12803	12	80	.135	1	144.00
CO121003	12	100	.135	1	179.00
CO14403	14	40	.156	1	137.00
CO14603	14	60	.156	1	144.00
CO14723	14	72	.156	1	161.00
CO14803	14	80	.156	1	164.00
CO141003	14	100	.156	1	196.00
CO16403	16	40	.156	1	148.00
CO16603	16	60	.156	1	162.00
CO16723	16	72	.156	1	181.00
CO16803	16	80	.156	1	187.00
CO161003	16	100	.156	1	207.00
CO18603	18	60	.160	1	227.00
CO18803	18	80	.160	1	237.00
CO181203	18	120	.160	1	283.00



**Custom Blades
Made To Order**

MELA-CRAFTER DOUBLE SIDED SAW BLADE

NO. MC10802
10" x 80 TEETH x 5/8" BORE x 30° ATB
\$109.95

VERY FINE CUTTING VENEER SAWS

COMBINATION PLANER SAW BLADES

VS SERIES Fine Veneer Saws 30°ATB

Order No.	Dia.	No. of Teeth	Kerf	Bore	Price
VS109002	10	90	.125	5/8	\$160.00
VS129002	12	90	.125	1	187.00
VS141002	14	100	.145	1	203.00
VS161202	16	120	.160	1	266.00
VS181202	18	120	.175	1	286.00
VS201302	20	130	.175	1	344.00



4.B.T.1.R.
#5

BLADES FOR MELAMINE PANELS

FOR TABLE MACHINES - HAND FEED
"SCORE-FREE/ATB" NO CHIPPING
FOR DOUBLE OR SINGLE COATED PANELS

Melamine (MCP), Polyester Coated Panels, Printed Surfaces,
Low and High Pressure Surfaces

DC SERIES "Score-Free" 30° ATB

Order No.	Dia.	No. of Teeth	Kerf	Bore	Price
DC087202	8	72	.095	5/8	\$145.00
DC109002	10	90	.110	5/8	159.00
DC121002	12	100	.120	1	199.00
DC141003	14	100	.136	1	225.00
DC161203	16	120	.145	1	275.00

CALL TOLL FREE 1-800-443-0992 • FAX TOLL FREE 1-888-728-8665
or visit our web site at www.ridgecarbide.com



SAW BLADES



RIP SAWS

HAND FEED, POWER FEED, GLUE JOINT

RSH SERIES Hand Feed Rip STR

Order No.	Dia.	No. of Teeth	Kerf	Bore	Price
RSH10241	10	24	.125	5/8	\$87.00
RSH12241	12	24	.140	1	110.00
RSH12301	12	30	.140	1	115.00
RSH12403	12	40	.140	1	122.00
RSH14241	14	24	.155	1	140.00
RSH14301	14	30	.155	1	145.00
RSH14403	14	40	.155	1	152.00
RSH16301	16	30	.165	1	160.00
RSH16403	16	40	.165	1	169.00

ALUMINUM CUTTING BLADES

NFT SERIES - Thin Wall Extrusions - TCG Grind

Order No.	Dia.	No. of Teeth	Kerf	Plate Gauge	Bore	Price
NFT086003	8	60	.095	.075	5/8	\$116.00
NFT096003	9	60	.105	.085	5/8	137.00
NFT107203	10	72	.115	.095	5/8	158.00
NFT108003	10	80	.115	.095	5/8	169.00
NFT101003	10	100	.115	.095	5/8	209.00
NFT129003	12	90	.115	.095	1	194.00
NFT121003	12	100	.115	.095	1	213.00
NFT141003	14	100	.125	.105	1	220.00
NFT141203	14	120	.125	.105	1	255.00

CORIAN® SAWS

PLC-BAT SERIES Corian®, Avonite®
Solid Surface Materials

Bat Grind; 5° Hook

Order No.	Dia.	No. of Teeth	Kerf	Bore	Price
PLC0848BAT	8	48	.128	5/8	#139.00
PLC1048BAT	10	48	.138	5/8	155.00
PLC1248BAT	12	48	.145	1	162.00
PLC1460BAT	14	60	.160	1	179.00
PLC1660BAT	16	60	.170	1	189.00

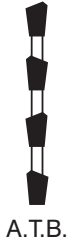

A.T.B.

PLC-9 SERIES Corian®, Avonite®
Solid Surface Materials

#9 TCG/AFB Grind; 5° Hook

Order No.	Dia.	No. of Teeth	Kerf	Bore	Price
PLC08609	8	60	.120	5/8	\$172.00
PLC10609	10	60	.128	5/8	199.00
PLC10809	10	80	.125	5/8	239.00
PLC12609	12	60	.150	1	219.00
PLC12809	12	80	.130	1	249.00
PLC14609	14	60	.160	1	235.00
PLC14809	14	80	.150	1	255.00
PLC161009	16	100	.155	1	292.00



#9

COMBINATION PLANER SAW BLADES

CP SERIES Combination Planer

Order No.	Dia.	No. of Teeth	Kerf	Bore	Price
CP08405	8	40	.120	5/8	\$78.00
CP09405	9	40	.124	5/8	86.00
CP10405	10	40	.124	5/8	86.00
CP10505	10	50	.124	5/8	96.00
CP10555	10	55	.124	5/8	105.00
CP12505	12	50	.135	1	108.00
CP12605	12	60	.135	1	118.00
CP14705	14	70	.160	1	167.00
CP16805	16	80	.160	1	189.00
CP18905	18	90	.175	1	260.00



4.B.T.1

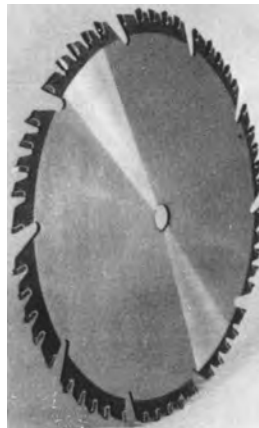

SAW BLADE SHARPENING AVAILABLE

See Back Cover

CALL TOLL FREE 1-800-443-0992 • FAX TOLL FREE 1-888-728-8665
or visit our web site at www.ridgecarbide.com



SAW BLADES



SLIDING TABLE PANEL MASTER BLADES

STP-3 SERIES (TCG) SLIDING TABLE

Order No.	Dia.	No. of Teeth	Kerf	Bore	Price
STP30060303	300MM	60	.135	30MM	\$150.00
STP30072303	300MM	72	.135	30MM	158.00
STP30080303	300MM	80	.135	30MM	165.00
STP300100303	300MM	100	.135	30MM	170.00
STP350100303	350MM	100	.145	30MM	223.00
STP35580303	14	80	.145	30MM	179.00
STP355100303	14	100	.145	30MM	223.00

STP-2 SERIES (30° ATB) SLIDING TABLE

Order No.	Dia.	No. of Teeth	Kerf	Bore	Price
STP30060302	300MM	60	.135	30MM	\$150.00
STP30072302	300MM	72	.135	30MM	158.00
STP30080302	300MM	80	.135	30MM	165.00
STP300100302	300MM	100	.135	30MM	170.00
STP350100302	350MM	100	.145	30MM	223.00
STP35580302	14	80	.145	30MM	179.00
STP355100302	14	100	.145	30MM	223.00

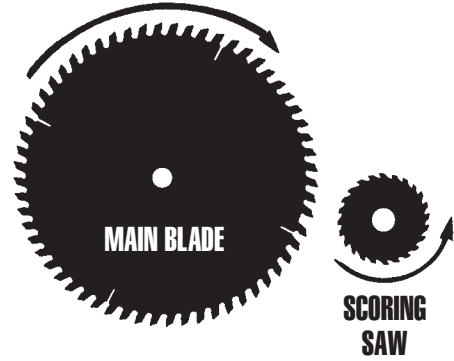

FULL SHARPENING AND REPAIR SERVICE ON ALL MAKES OF SAW BLADES, BITS, CUTTERS AND KNIVES.



SPLIT TYPE SCORING SAWS

SSS SERIES SPLIT SCORING SAWS

Order No.	Dia.	No. of Teeth	Kerf	Bore	Price
SSS1001020	100MM	2x10	2.8/3.6	20MM	\$112.00
SSS1201020	120MM	2x12	2.8/3.6	20MM	115.00
SSS1001022	100MM	2x10	2.8/3.6	22MM	112.00
SSS1201222	120MM	2x12	2.8/3.6	22MM	115.00
SSS1251222	125MM	2x12	2./3.6	22MM	145.00
SSS1001075	100MM	2x10	2.8/3.6	3/4	112.00
SSS1201275	120MM	2x12	2.8/3.6	3/4	115.00
SSS082045	8	2x20	4.6/5.8	45MM	265.00

VERTICAL PANEL MASTER BLADES

VP SERIES - VERTICAL PANEL BLADES

30° Order No.	TCG Order No.	2+1 ATB Order No.	Dia.	No. of Teeth	Kerf	Bore	Price
VP08802	VP08803		8	80	.125	5/8	\$149.00
VPN08602	VP08603		8	60	.110	5/8	109.00
		VP08487	8	48	.125	5/8	92.00
VP22042302	VP22042303		220MM	42	.110	30MM	119.00
VP22064302	VP22064303		220MM	64	.110	30MM	105.00
VP22070302	VP22070303		220MM	70	.130	30MM	139.00
VP30072302	VP30072303	VP30072307	300MM	72	.120	30MM	158.00
VP300100302	VP300100303		300MM	100	.120	30MM	170.00



CALL TOLL FREE 1-800-443-0992 • FAX TOLL FREE 1-888-728-8665 or visit our web site at www.ridgecarbide.com



PLASTIC CUTTING SAW BLADES



THIN KERF & THIN RIM BLADES

THIN RIM BLADES

TR SERIES - Thin Rim & Thin Kerf Blades

Order No.	Dia.	No. of Teeth	Kerf	Plate Gauge	Bore	Price
TR086003	8	60	.075	2	5/8	\$172.00
TR087203	8	72	.075	2	5/8	189.00
TR108003	10	80	.080	2	5/8	199.00
TR101003	10	100	.080	2	5/8	249.00
TR129003	12	90	.085	2	1	245.00
TR121003	12	100	.085	2	1	259.00
TR141003	14	100	.090	2	1	279.00

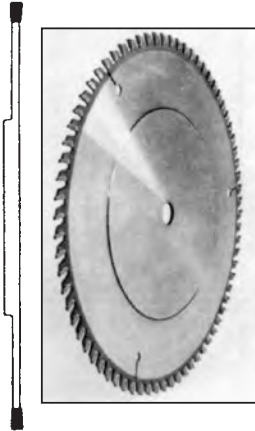

T.C.G.

1/16" KERF THIN RIM BLADES

TR -1/16" SERIES

Order No.	Dia.	No. of Teeth	Kerf	Plate Gauge	Bore	Price
TR08600316	8	60	1/16	2	5/8	\$189.00
TR08720316	8	72	1/16	2	5/8	209.00
TR0880316	8	80	1/16	2	5/8	228.00
TR1800316	10	80	1/16	2	5/8	218.00
TR10100216	10	100	1/16	2	5/8	265.00
TR12900316	12	90	1/16	2	1	259.00
TR12100316	12	100	1/16	2	1	275.00



THIN LINE SAWS

THIN KERF - MATERIAL SAVER
THIN KERF THIN PLATE
THIN LINE BLADES

TL SERIES - Thin Kerf Blades

Order No.	Dia.	No. of Teeth	Kerf	Plate Gauge	Bore	Price
TL086004	8	60	.080	.060	5/8	\$159.00
TL087204	8	72	.080	.060	5/8	175.00
TL108004	10	80	.085	.065	5/8	192.00
TL128004	12	80	.095	.070	5/8	199.00
TL121004	12	100	.095	.070	1	245.00



T.C.G.



LOW MELT THIN KERF BLADES

Extruded Acrylics and Other Heat Sensitive Plastics; Modified TCG Grind

TLL SERIES

Order No.	Dia.	No. of Teeth	Kerf	Plate Gauge	Bore	Price
TLL10804	10	80	.105	.065	5/8	\$199.00
TLL121004	12	100	.105	.065	1	245.00

STANDARD KERF PLASTIC BLADES

Low Melt Design for Acrylics
PLL SERIES for Extruded Acrylics
and heat sensitive plastics

Low Melt Geometry & Modified TCG Grind

Order No.	Dia.	No. of Teeth	Kerf	Plate Gauge	Bore	Price
PLL08724	8	72	.115	.083	5/8	\$156.00
PLL10724	10	72	.135	.095	5/8	178.00
PLL10804	10	80	.135	.095	5/8	199.00
PLL109004	10	90	.120	.085	5/8	210.00
PLL12804	12	80	.155	.115	1	210.00
PLL121004	12	10	.145	.110	1	236.00
PLL14804	14	80	.165	.118	1	236.00
PLL141004	14	100	.165	.118	1	266.00
PLL16804	16	80	.165	.118	1	246.00
PLL161204	16	120	.165	.118	1	295.00
PLL181004	18	100	.170	.125	1	299.00
PLL181304	18	130	.170	.125	1	335.00

CALL TOLL FREE 1-800-443-0992 • FAX TOLL FREE 1-888-728-8665
or visit our web site at www.ridgecarbide.com



CARBIDE TIPPED GROOVERS



RIP STYLE GROOVERS STRAIGHT TOP & FACE

RG SERIES - RIP Groovers

Order No.	Dia.	No. of Teeth	Kerf	Bore	Price
RG6614	6	6	1/4	5/8	\$150.00
RG6638	6	6	3/8	5/8	156.00
RG6612	6	6	1/2	5/8	168.00
RG6658	6	6	5/8	5/8	QUOTE
RG6634	6	6	3/4	5/8	QUOTE
RG81214	8	12	1/4	5/8 or 1	190.00
RG82414	8	24	1/4	5/8	235.00
RG81238	8	12	3/8	5/8 or 1	199.00
RG81212	8	12	1/2	5/8 or 1	208.00
RG81258	8	12	5/8	5/8 or 1	QUOTE
RG81234	8	12	3/4	5/8 or 1	QUOTE
RG102414	10	24	1/4	5/8 or 1	270.00
RG102438	10	24	3/8	5/8 or 1	270.00
RG102412	10	24	1/2	5/8 or 1	300.00
RG102458	10	24	5/8	5/8 or 1	QUOTE
RG102434	10	24	3/4	5/8 or 1	QUOTE
RG122414	12	24	1/4	1	287.00
RG122438	12	24	3/8	1	311.00
RG122412	12	24	1/2	1	344.00
RG122458	12	24	5/8	1	QUOTE
RG122434	12	24	3/4	1	QUOTE



S.T.G.

*For bore sizes
other than listed
Add \$19.00*



A.S.F.G.

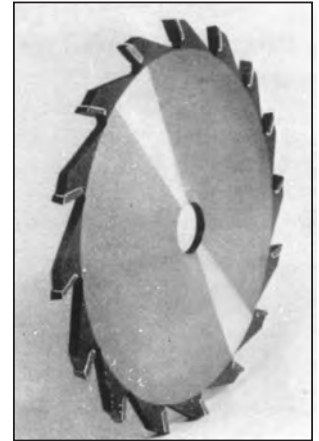

**CUSTOM GROOVERS MADE TO ORDER
CALL FOR PRICE QUOTE**

REPLACEMENT BISCUIT JOINER BLADE

Fits - Lamello, Porter-Cable,
Virutex, Fried, Kaiser, ELU, etc.

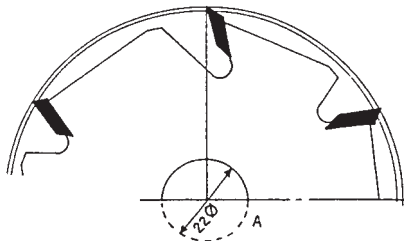

Order No.	Dia.	No. of Teeth	Bore	Price
LAM10012	100MM	12	22MM	\$59.95

COMBINATION GROOVERS ALTERNATE SHEAR FACE STRAIGHT TOP

CG SERIES - AFB Groovers

Order No.	Dia.	No. of Teeth	Kerf	Bore	Price
CG62414	6	24	1/4	5/8	\$258.00
CG62438	6	24	3/8	5/8	300.00
CG62412	6	24	1/2	5/8	324.00
CG62458	6	24	5/8	5/8	QUOTE
CG62434	6	24	3/4	5/8	QUOTE
CG82414	8	24	1/4	5/8 or 1	264.00
CG82438	8	24	3/8	5/8 or 1	312.00
CG82412	8	24	1/2	5/8 or 1	342.00
CG82458	8	24	5/8	5/8 or 1	QUOTE
CG82434	8	24	3/4	5/8 or 1	QUOTE
CG102414	10	24	1/4	5/8 or 1	298.00
CG102438	10	24	3/8	5/8 or 1	323.00
CG102412	10	24	1/2	5/8 or 1	384.00
CG102458	10	24	5/8	5/8 or 1	QUOTE
CG102434	10	24	3/4	5/8 or 1	QUOTE
CG122414	12	24	1/4	1	335.00
CG122438	12	24	3/8	1	408.00
CG122412	12	24	1/2	1	474.00
CG122458	12	24	5/8	1	QUOTE
CG122434	12	24	3/4	1	QUOTE

**CALL TOLL FREE 1-800-443-0992 • FAX TOLL FREE 1-888-728-8665
or visit our web site at www.ridgecarbide.com**



LIBERTY LINE ROUTER BITS

TOP RATED BY FINE WOODWORKING MAGAZINE



CARBIDE TIPPED STRAIGHT PLUNGE CUTTING BITS

RCT'S LIBERTY BITS ARE PREMIUM MANUFACTURED WITH THE FINEST MICRO-GRAIN CARBIDE AND ARE PRECISION GROUND TO A RAZOR SHARP EDGE TO GIVE BOTH THE PROFESSIONAL AND AMATEUR WOODWORKER LONG CUTTING LIFE.

ROUTER TEST RESULTS FINE WOODWORKING MAGAZINE ISSUE #137 AUGUST 1999

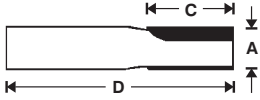

1/4" SHANK - 2 FLUTES

Order No.	A Diameter	C Cut Length	Overall Length	Price
SC01	1/16	5/16	1-1/2	\$ 23.00
10-105	1/8	7/16	2	16.00
10-115	3/16	7/16	2	17.20
10-SC13	7/32	3/4	2	21.00
10-125	1/4	1/2	2	16.25
10-135	1/4	3/4	2	16.25
10-145	1/4	1	2-1/4	16.75
10-150	1/4	1	2-7/8	19.25
10-155	9/32	1	2-1/4	18.70
10-160	5/16	1	2-1/4	17.35
10-165	3/8	3/4	1-3/4	17.50
10-170	3/8	1	2-1/4	18.50
10-175	7/16	1	2-1/8	20.35
10-1024A	31/64	3/4	2-1/4	21.00
10-180	1/2	3/4	1-3/4	18.70
10-185	1/2	1	2-1/8	19.25
10-190	9/16	3/4	2	19.80
*10-1027A	19/32	3/4	2-1/4	21.00
10-195	5/8	3/4	2	20.70
10-200	11/16	3/4	2	24.00
*10-1029A	23/32	3/4	2-1/8	24.00
10-205	3/4	3/4	2	22.55
10-210	13/16	3/4	2	25.00
10-1033	1	3/4	2-1/8	26.00
10-1303	1-1/4	1/2	2-1/8	30.00

* Undersized Dado Bit

- CNC GRADE BITS ADD 20% TO CATALOG TOOL PRICE.
- SPECIAL OR METRIC SIZES MADE TO ORDER.
- FLAT BOTTOM BORING POINT ADD \$10.00 TO CATALOG PRICE.
- V BOTTOM BORING POINT ADD \$12.00 TO CATALOG PRICE
- LEFT HAND BITS AVAILABLE.



MORTISING BITS

2 FLUTES

Order No.	A Cutting Diameter	Shank Diameter	C Cutting Diameter	D Overall Length	Price
10-600	1/2	1/4	3/4	1-3/4	\$ 17.60
10-605	5/8	1/4	3/4	2	21.75
10-610	3/4	1/4	3/4	2	22.25

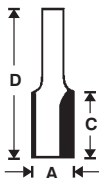

1/2" SHANK - 2 FLUTES

Order No.	A Diameter	C Cut Length	Overall Length	Price
10-240	1/4	3/4	2-1/2	\$ 20.50
10-1059	9/32	3/4	2-3/8	21.00
10-250	5/16	3/4	2-1/2	20.70
10-255	5/16	1	2-3/4	20.35
10-270	3/8	1	2-3/4	20.00
10-275	3/8	1-1/4	3	22.00
*10-1064	13/32	1	2-1/2	20.00
10-280	7/16	1-1/4	3	24.00
*10-1065A	31/64	1	2-5/8	20.00
10-285	1/2	1	2-5/8	20.00
10-295	1/2	1-1/4	2-7/8	20.35
10-305	1/2	1-1/2	3-1/8	21.50
10-320	1/2	2	4-1/4	27.30
10-325	1/2	2-1/2	4-1/2	37.50
*10-1074	17/32	1-1/4	2-7/8	23.00
10-335	9/16	1-1/4	2-7/8	23.75
*10-1075A	19/32	3/4	2-1/4	22.00
10-350	5/8	1-1/4	2-7/8	26.60
10-1080	21/32	1-1/4	3	26.00
10-360	11/16	1-1/4	2-7/8	28.60
10-370	3/4	1-1/4	2-7/8	26.70
10-1087	3/4	2	3-5/8	34.00
10-380	25/32	1-1/4	2-3/4	32.00
*10-1083A	23/32	1	2-1/2	23.00
10-385	13-16	1-1/4	2-7/8	30.80
10-390	7/8	1-1/4	2-7/8	31.00
10-395	1	1-1/4	2-7/8	31.90
10-400	1-1/4	1-1/4	2-7/8	42.00
10-405	1-1/2	1-1/4	2-7/8	48.00
10-410	1-3/4	1-1/4	2-7/8	64.50
10-415	2	1-1/4	2-7/8	82.00

* Undersized Dado Bit - CNC 3/4" Shank Tools available - call for size & price.



STAGGER TOOTH

PLUNGE CUTTING ROUTER BITS

Order No.	A Cutting Diameter	Shank Diameter	C Cutting Diameter	D Overall Length	Price
10-500	1/4	1/4	1	2-1/4	\$ 19.75
10-505	3/8	3/8	1-3/8	3	23.70
10-510	3/8	1/2	1-1/2	3-1/8	25.00
10-515	1/2	1/2	1-1/2	3-1/8	25.75
10-520	1/2	1/2	2	4-1/4	28.25
10-525	1/2	1/2	2-1/4	4-1/2	37.00

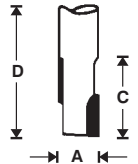

CALL TOLL FREE 1-800-443-0992 • FAX TOLL FREE 1-888-728-8665
 or visit our web site at www.ridgecarbide.com



LIBERTY LINE ROUTER BITS

TOP RATED BY FINE WOODWORKING MAGAZINE



SPIRAL SHEAR FACE

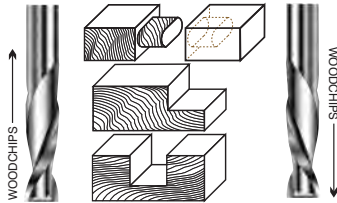

Two flute flat bottom cutters. Top quality micrograin solid carbide. Will cut faster, smoother, and stays sharper longer. Produces a very clean, fast and accurate cut with minimal chatter. Upcut spiral helps remove material. Ideal for making mortise and tenon joints. Downcut spirals help hold the material in place while using handheld routers. Will plunge cut and plane edges. Eliminates chipping at the top of the cut. Ideal for soft & hardwoods, plywoods & composite, laminates, plastics and some non-ferrous metals.

Custom Bits Made To Order

SPIRAL UP-SHEAR FLUSH TRIM BIT

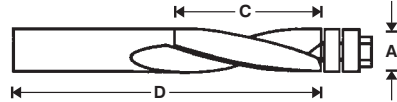

2 BALL BEARING GUIDES - 2 FLUTES

Order No.	A Cutting Diameter	Shank Diameter	C Cutting Length	D Overall Length	Price
14-300	1/2	1/2	1-1/4	3	\$114.40
14-320	1/2	1/2	1-1/2	3-1/4	126.50
14-340	1/2	1/2	2	3-3/4	132.00
*14-365	1/2	1/2	1-1/4	3-3/4	154.00

*Compression Bit

12-145	Replacement Bearing Guide				4.50
--------	---------------------------	--	--	--	------

SPIRAL UPCUT BITS

SPIRAL DOWNCUT BITS

UP CUT	DOWN CUT	A Cutting Diameter	Shank Diameter	C Cutting Length	D Overall Length	Price
10-800	10-805	1/8	1/8	1/2	1-1/2	\$19.80
10-810	10-815	1/8	1/4	1/2	2	25.75
10-820	10-825	5/32	1/4	1/2	2-1/2	27.75
10-840	10-845	3/16	1/4	1/2	2-1/2	28.50
10-850	10-855	3/16	1/4	1/2	2-1/2	26.75
10-860	10-865	7/32	1/4	1	2-1/2	27.00
10-870	10-875	1/4	1/4	3/4	2-1/2	27.50
10-880	10-885	1/4	1/4	1	2-1/2	28.60
10-4800U	10-4800D	9/32	1/2	1	3	69.00
10-4850U	10-4850D	5/16	1/2	1	3	55.00
10-890	10-895	3/8	3/8	1	2-1/2	55.00
10-4875U	10-4875D	3/8	1/2	3/4	3	55.00
10-4900U	10-4900D	3/8	1/2	1-1/4	3	56.00
10-4950U	10-4950D	7/16	1/2	1-1/4	3	65.00
10-900	10-905	1/2	1/2	1-1/4	3	77.00
10-910	10-915	1/2	1/2	2	4	101.00

WE SHARPEN SPIRAL BITS



COMPRESSION UP/DOWN SPIRAL BIT

One and two flute solid carbide bit is needed to get clean, chip-free and splinter-free cuts in composite sheet goods such as Melamine or 2-sided Formica/Laminates and veneered plywood. The Up-shear/Down-shear design of the bit cuts toward the center of the sheet from both sides at once, saving time and eliminating waste.

ONE & TWO FLUTES

Order No.	Flutes	A Cutting Diameter	Shank Diameter	C Cutting Length	D Overall Length	Price
10-940	1	1/4	1/4	7/8	2-1/2	\$60.50
10-952	2	3/8	3/8	1	3	72.60
10-960	1	1/2	1/2	1-1/8	3	99.00
10-962	2	1/2	1/2	1-1/8	3	102.50
10-967	2	1/2	1/2	1-1/4	3	103.40
10-970	1	1/2	1/2	1-5/8	3-1/2	118.80
10-972	2	1/2	1/2	1-5/8	3-1/2	125.00



BEVEL PANEL PILOT BIT

7° ANGLE - 1 FLUTE

Order No.	Shank Diameter	C Cutting Length	D Overall Length	Price
14-805	1/4	1/4	1-1/2	\$12.93

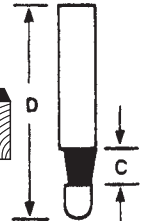

FLUSH PANEL PILOT BIT

1 FLUTE

Order No.	Shank Diameter	C Cutting Length	D Overall Length	Price
14-800	1/4	1/4	1-1/2	\$13.00
14-802	SM. PILOT/DADO CUT			15.00

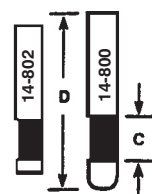

BEVEL TRIM BITS

WITH BALL BEARING GUIDE

Order No.	Flutes	Bevel	Shank Diameter	C Cutting Length	Price
16-200	3	7°	1/4	3/8	\$32.45
16-205	2	15°	1/4	1/4	23.65
16-210	3	23°	1/4	3/8	30.80
16-215	2	25°	1/4	1/4	24.20
16-220	2	45°	1/4	1/4	28.05
Replacement Bearing Guide					
12-145	For 2 Flute Bits				4.50
12-160	For 3 Flute Bits				5.00



CALL TOLL FREE 1-800-443-0992 • FAX TOLL FREE 1-888-728-8665
or visit our web site at www.ridgecarbide.com



GLUE WELL TRIM BITS



TIRED OF BEARING BURNOUT?
New Glue Well™ Trim Bits

FLUSH TRIM BITS

Standard flush trim router bits clog with adhesive. The glue adheres to the bearing quickly during trimming. To prevent bearing burn, you have to clean the bit regularly and cleaning it reduces your productivity and profits.



Standard flush trim router bit bearing clogged with contact adhesive.

The patented American made Glue Well™ prevents seizure. The specially designed and engineered glue reservoir traps the contact adhesive before it can reach the bearing surface. Adhesive free bearings guarantee you smoother and longer trimming.



Patented Glue Well™ Flush Trim router bit bearing is free of contact adhesive after extensive use.

Order No.	Flutes	Cutting Diameter	Shank Diameter	Cutting Length	No. of Bearings	Price
14-118	2	3/8	1/4	1/2	1	\$21.50
14-128	2	1/2	1/4	1/2	1	20.70
14-143	2	1/2	1/2	1/2	1	24.20
14-173	3	1/2	1/4	1/2	1	28.70
14-183	3	1/2	1/2	1/2	1	29.20
14-118A	2	3/8	1/4	1/2	2	26.50
14-128A	2	1/2	1/4	1/2	2	25.70
14-143A	2	1/2	1/2	1/2	2	29.20
14-173A	3	1/2	1/4	1/2	2	33.70
14-183A	3	1/2	1/2	1/2	2	34.20

100% SATISFACTION
 OR YOUR MONEY BACK!

GLUE WELL™ BEVEL TRIM ROUTER BITS

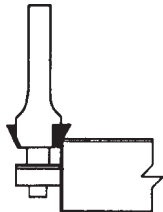

CARBIDE TIPPED WITH BEARING GUIDE

Order No.	Flutes	Bevel	Shank Diameter	Cutting Length	Price
16-208	2	15°	1/4	1/4	\$24.85
16-218	2	25°	1/4	1/4	25.40
12-145	Replacement Bearing Guide				4.50

LAMINATE TRIM BIT

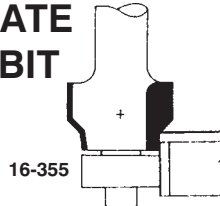

GLUE WELL™ LAMINATE TRIM BIT



New Laminate Trim Bit has eliminated the tedious, time consuming task of hand filling of laminates. The Glue Well Laminate Trim Bits with its specially designed and engineered glue reservoir traps the contact adhesive before it can reach the bearing surface. Adhesive free bearings, plus its unique double bevel design assures a smoother and more accurate finished product.

SAVES TIME AND MONEY - NO MORE HAND FILING

Order No.	Glue Well	Cutting Diameter	Flute Length	Shank Diameter	Overall Length	Price
16-355	NO	1/2	3/8	1/4	1-3/4	\$32.50
16-356	YES	1/2	3/8	1/4	1-3/4	32.50
12-135	Replacement Bearing Guide					5.00

DADO CLEANOUT BITS

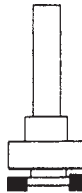

Order No.	No. of Wings	Diameter	Shank	Cutting Length	Price
14-460	2	1/2	1/4	1/8	\$34.00
14-465	2	5/8	1/4	1/8	36.00
14-470	2	3/4	1/4	1/8	39.00
12-120	Replacement Bearing Guide for 14-460				9.00
12-160	Replacement Bearing Guide for 14-465				5.00
12-165	Replacement Bearing Guide for 14-470				5.50

SPLINE CUTTERS



Order No.	Dia.	No. of Wings	Shank Diameter	Kerf	Price
50-125	2"	4	1/4	1/8	\$95.00
50-093	2"	4	1/4	3/32	95.00
50-250	2"	4	1/4	1/4	95.00
51-250	2"	4	1/2	1/4	95.00
53-125	2-1/2"	10	1/2	1/8	130.00
53-187	2-1/2"	10	1/2	3/16	130.00
53-250	2-1/2"	10	1/2	1/4	130.00

CALL TOLL FREE 1-800-443-0992 • FAX TOLL FREE 1-888-728-8665
 or visit our web site at www.ridgecarbide.com



LIBERTY LINE ROUTER BITS

TOP RATED BY FINE WOODWORKING MAGAZINE

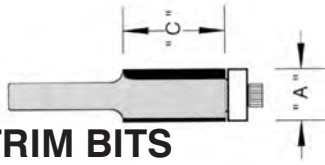

FLUSH TRIM BITS

WITH BALL BEARING GUIDE

Order No.	Number of Bearings	Flutes	A Cutting Diameter	Shank Diameter	C Cutting Length	Price
14-020	1	2	3/8	1/4	1-1/4	\$31.00
14-050	1	2	3/8	1/2	1	32.00
14-065	1	2	1/2	1/2	1-1/4	41.00
14-070	1	2	5/8	1/2	1	42.00
14-075	1	2	5/8	1/2	1-1/4	45.00
14-080	1	2	5/8	1/2	1-1/2	48.00
14-100	1	2	1/4	1/4	1/2	29.70
14-105	1	2	1/4	1/4	3/4	29.70
14-110	1	2	1/4	1/4	1	30.80
14-112	1	2	1/4	1/4	1-1/4	25.20
14-115	1	2	3/8	1/4	1/2	20.30
14-120	1	2	3/8	1/4	1	20.40
14-125	1	2	1/2	1/4	1/2	19.50
14-130	1	2	1/2	1/4	1	19.75
14-134	1	2	3/4	1/4	3/4	41.00
14-135	1	2	1/2	3/8	1	25.00
14-138	1	2	1/4	1/2	1	37.00
14-140	1	2	1/2	1/2	1/2	23.00
14-145	1	2	1/2	1/2	1	22.00
14-150	1	2	1/2	1/2	1-1/2	33.00
14-155	2	2	1/2	1/2	1-1/2	46.00
14-160	1	2	1/2	1/2	2	36.20
14-165	2	2	1/2	1/2	2	49.50
14-170	1	3	1/2	1/4	1/2	27.50
14-175	1	3	1/2	1/4	1	28.00
14-180	1	3	1/2	1/2	1/2	28.00
14-185	1	3	1/2	1/2	1	29.20
14-190	1	3	1/2	1/2	1-1/2	43.00
14-195	2	3	1/2	1/2	1-1/2	56.00
14-196	1	2	1/2	1/2	2-1/2	56.00
14-208	1	2	5/8	1/2	2	58.00
14-209	1	2	5/8	1/2	2-1/2	72.00
14-215	1	2	3/4	1/2	1-1/4	41.00
14-220	1	2	3/4	1/2	1-1/2	44.00
14-225	1	2	3/4	1/2	1-3/4	48.00
14-228	1	2	3/4	1/2	2	73.00

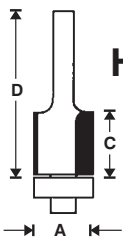

HELIX FLUSH TRIM BITS



WITH BALL BEARING GUIDE - 2 FLUTES

Order No.	A Cutting Diameter	Shank Diameter	C Cutting Length	D Overall Length	Price
14-200	3/4	1/4	5/8	2	\$29.50
14-205	3/4	1/2	5/8	2	30.25
12-165	Replacement Ball Bearing Guide				5.50

PATTERN/TEMPLATE FLUSH TRIM BITS



WITH BALL BEARING GUIDE - 2 FLUTES

Order No.	A Cutting Diameter	Shank Diameter	C Cutting Length	Price
14-442	3/8	1/4	1/2	\$31.00
14-445	3/8	1/4	1/2	31.75
14-447	3/8	1/4	1	32.50
14-400	1/2	1/4	1/2	31.25
14-405	1/2	1/4	3/4	30.55
14-410	1/2	1/4	1	32.00
14-415	5/8	1/4	3/4	32.45
14-420	3/4	1/4	3/4	34.38

Replacement Bearing Guides

12-120	1/2" Cutting Diameter	9.00
12-160	5/8" Cutting Diameter	5.00
12-165	3/4" Cutting Diameter	5.50
14-422	3/4 1/2 1	45.10
14-423	3/4 1/2 1-1/4	48.40
14-421	3/4 1/2 1-1/2	51.20
14-437	3/4 1/2 2	69.00
14-424	1 1/2 1-3/4	74.50
14-425	1-1/8 1/2 1-1/4	74.00
14-430	1-1/8 1/2 1-1/2	72.60
14-435	1-1/8 1/2 2	90.75

Replacement Bearing Guides

12-173	3/4" Cutting Diameter	15.00
12-175	1" Cutting Diameter	22.00
12-170	1-1/8" Cutting Diameter	8.00
LC-1/4	Lock Collars 1/4"	6.00
LC-1/2	Lock Collars 1/2"	6.00

FLUSH TRIM "V" GROOVE BITS

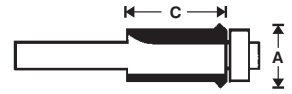

WITH BALL BEARING GUIDE - 2 FLUTES

Order No.	A Cutting Diameter	Shank Diameter	C Cutting Length	Price
14-600	5/8	1/4	1	\$39.50
14-605	5/8	1/2	1	37.95
12-145	Replacement Ball Bearing Guide			4.50

OVERHANG TRIM BITS

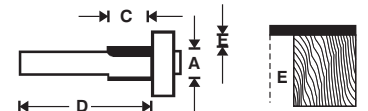

WITH BALL BEARING GUIDE - 2 FLUTES

Order No.	A Cutting Diameter	Shank Diameter	C Cutting Length	D Overall Length	E Overhang	Price
14-500	3/8	1/4	1/2	1-7/8	1/8	\$27.50
14-505	3/8	1/4	1/2	1-7/8	3/16	28.50
Replacement Ball Bearing Guide						
12-160	for 1/8" Overhang					5.00
12-165	for 3/16" Overhang					5.50

CALL TOLL FREE 1-800-443-0992 • FAX TOLL FREE 1-888-728-8665
or visit our web site at www.ridgecarbide.com



LIBERTY LINE ROUTER BITS

TOP RATED BY FINE WOODWORKING MAGAZINE

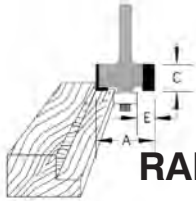

RABBETING BITS



WITH BALL BEARING GUIDE - 2 FLUTES

Order No.	A Cutting Diameter	Shank Diameter	C Cutting Length	D Depth of Rabbet	Price
15-100	1	1/4	1/2	1/4	\$36.75
15-105	1	1/2	1/2	1/4	38.75
15-110	1-1/4	1/4	1/2	3/8	36.75
15-115	1-1/4	1/2	1/2	3/8	38.75
15-120*	1-3/8*	1/4*	1/2*	1/2*	40.75
15-125	1-1/2	1/2	3/4	1/2	41.75
15-135	1-3/4	1/2	7/8	5/8	102.00
15-140	2	1/2	1	3/4	108.50
15-145	2-1/2	1/2	1	1-1/16	145.00
12-145	Replacement Bearing Guide				4.50
12-135	Replacement Bearing Guide*				5.00

STRAIGHT FLUTE

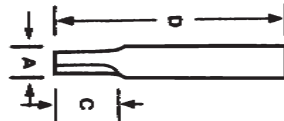

PLUNGE CUTTING ROUTER BITS - 2 FLUTES

Order No.	A Cutting Diameter	Shank Diameter	C Cutting Length	D Overall Length	Price
10-700	1/8	1/8	1/2	1-1/2	\$21.00
10-705	3/16	3/16	3/4	2	23.00
10-710	1/8	1/4	1/2	2	21.75
10-715	3/16	1/4	1/2	2	22.50
10-720	1/4	1/4	3/4	2-1/2	24.20
10-725	1/4	1/4	1	2-1/2	25.75

RABBIT BIT BEARING CONVERSION KIT

#SBE200: Complete Kit

including 4 bearings, hex key, washer and screw.



Get 4 depths of cut from just one bit!

\$19.95

1/2 Rabbet; 7/16 Rabbet; 3/8 Rabbet; 5/16 Rabbet

RABBETING SET

Five different depths of rabbet - 1/4, 5/16, 3/8, 7/16 and 1/2

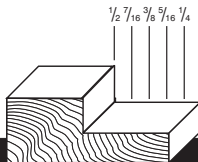

2 FLUTES

Order No.	A Cutting Diameter	Shank Diameter	C Cutting Length	Price
15-150	1-1/4	1/4	1/2	\$50.00
15-155	1-1/4	1/2	1/2	52.00
15-1965	2	1/2	1	84.00

ROUND BOTTOM VEINING BITS



Order No.	Radius	A Cutting Diameter	Shank Diameter	D Overall Length	Price
28-100	1/16	1/8	1/4	2	\$17.50
28-105	3/32	3/16	1/4	2	17.50
28-110	1/8	1/4	1/4	2	17.50

EXTRA DEEP MULTI RABBIT SET

Our Largest Set with 8 Piece Bearing Kit
Includes 3/8", 5/8", 11/16", 3/4" 7/8", 1" Bearings
To Cut Rabbets Shown Below



ALL THESE RABBETS CAN BE CUT WITH TOOL #15-1965

Rabbeting Depth



"V" GROOVING VEINING BIT



90° INCLUDED ANGLE

Order No.	A Cutting Diameter	Shank Diameter	D Overall Length	Price
28-200	1/4	1/4	2	\$17.50

CALL TOLL FREE 1-800-443-0992 • FAX TOLL FREE 1-888-728-8665
or visit our web site at www.ridgecarbide.com



LIBERTY LINE ROUTER BITS

TOP RATED BY FINE WOODWORKING MAGAZINE



BEADING BITS



ROUNDING OVER BITS



WITH BALL BEARING - 2 FLUTES

BEADING Order No.	ROUND OVER Order No.	R Radius	A Cutting Diameter	Shank Diameter	C Cutting Length	Price
22-200	22-300	1/16	5/8	1/4	5/16	\$39.00
22-205	22-305	1/16	5/8	1/2	5/16	42.00
22-210	22-310	1/8	3/4	1/4	3/8	38.25
22-215	22-315	1/8	3/4	1/2	3/8	40.25
22-220	22-320	5/32	13/16	1/4	3/8	41.00
22-225	22-325	3/16	7/8	1/4	3/8	38.50
22-230	22-330	3/16	7/8	1/2	3/8	39.75
22-235	22-335	1/4	1	1/4	7/16	39.00
22-240	22-340	1/4	1	1/2	7/16	39.75
22-245	22-345	5/16	1-1/8	1/4	1/2	40.50
33-250	22-350	5/16	1-1/8	1/2	1/2	43.00
22-255	22-355	3/8	1-1/4	1/4	5/8	40.50
22-260	22-360	3/8	1-1/4	1/2	5/8	42.00
22-265	22-365	1/2	1-1/2	1/4	3/4	45.00
22-270	22-370	1/2	1-1/2	1/2	3/4	45.50
22-275	22-375	5/8	1-3/4	1/2	7/8	67.00
22-280	22-380	3/4	2	1/2	1	71.50
22-285	22-385	7/8	2-1/4	1/2	1-1/8	126.00
22-290	22-390	1	2-1/2	1/2	1-1/4	141.00
To Convert To Beading Bits Add Bearing #12-135 To Your Order	22-395	1-1/8	2-3/4	1/2	1-3/8	176.00
	22-400	1-1/4	3	1/2	1-1/2	181.50
	22-405	1-3/8	3-1/4	1/2	1-5/8	187.00
	22-410	1-1/2	3-1/2	1/2	1-3/4	203.50
	22-415	3/32	5/8	1/4	3/8	44.00
	22-430	7/16	1-1/4	1/4	5/8	66.00
	22-435	7/16	1-1/4	1/2	5/8	68.20
	22-440	9/16	1-1/2	1/2	3/4	71.50
	22-445	11/16	1-3/4	1/2	7/8	79.20
	22-450	13/16	2	1/2	1	90.20

Replacement Bearing Guides

12-135	Beading Bit	5.00
12-145	Round Over Bit	4.50

LOCK MORTISING BITS

2 FLUTES - SCREW TYPE 1/4 - 28 THREAD

Order No.	A Cutting Diameter	C Cutting Diameter	Price
11-100	3/4	1/2	\$34.00
11-105	13/16	1/2	34.00
11-110	7/8	1/2	34.00
11-115	15/16	1/2	34.00
11-120	1	1/2	34.00
11-125	1-1/8	9/16	34.00
11-130	1-1/4	5/8	30.25

ARBORS FOR ABOVE

13-130	1/4 diameter shank	5.50
13-135	1/2 diameter shank	5.50

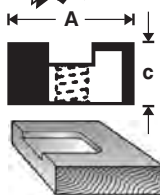

PLUNGE CUTTING ROUNDING OVER BITS

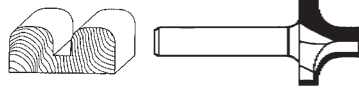

2 FLUTES

Order No.	R Radius	Large Cutting Diameter	A Shank Diameter	Cutting Length	C Overall Length	D Small Diameter	Price
22-100	1/8	3/8	1/4	1/8	1-7/8	1/8	\$33.00
22-105	1/8	3/8	1/2	1/8	2	1/8	37.75
22-110	3/16	1/2	1/4	1/4	1-7/8	1/8	45.00
22-115	3/16	1/2	1/2	1/4	2	1/8	51.00
22-120	1/4	3/4	1/4	3/8	1-7/8	1/4	54.00
22-125	1/4	3/4	1/2	3/8	2	1/4	57.50
22-130	5/16	7/8	1/2	7/16	2-1/8	1/4	58.85
22-135	3/8	1	1/2	1/2	2-1/8	3/8	61.60
22-140	1/2	1-3/8	1/2	3/4	2-3/8	3/8	74.80
22-145	5/8	1-3/4	1/2	1	2-5/8	1/2	83.60
22-150	3/4	2	1/2	1-1/8	2-7/8	1/2	93.50

ROUNDROVER LONG NOSE EDGE TRIM BITS



1/2" SHANK

Order No.	R Radius	Large Cutting Diameter	A Shank Diameter	Cutting Length	C Overall Length	D Small Diameter	Price
*22-2068	3/16	1	1/2	13/16	2-5/8	1/2	\$68.00
**22-2070	3/16	1	1/2	1-5/16	3-1/8	1/2	90.00
*22-2072	1/4	1-1/8	1/2	13/16	2-5/8	1/2	79.00
**22-2074	1/4	1-1/8	1/2	1-5/16	3-1/4	1/2	101.00
*22-2076	3/8	1-3/8	1/2	1-3/16	2-3/4	1/2	90.00
**22-2078	3/8	1-3/8	1/2	1-5/16	3-1/4	1/2	110.00

*Edge Trim for 3/4" Stock **Edge Trim for 1-1/4" Stock

POINT CUTTING ROUNDROVER

A great bit for sign making, turning legs, surface design, etc.

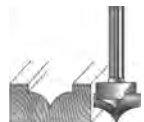

DECORATIVE TRIMMING & LETTERING

Order No.	Radius	Cutting Diameter	Shank Diameter	Cutting Length	Overall Length	Price
10-1570	3/16	3/8	1/4	3/8	2	\$26.00
10-1572	1/4	1/2	1/4	3/8	2	30.00
10-1574	3/8	3/4	1/4	5/8	2	34.00
10-1580	3/8	3/4	1/2	5/8	2	36.00

CALL TOLL FREE 1-800-443-0992 • FAX TOLL FREE 1-888-728-8665
or visit our web site at www.ridgecarbide.com



LIBERTY LINE ROUTER BITS

TOP RATED BY FINE WOODWORKING MAGAZINE

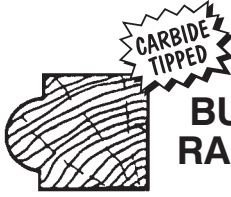
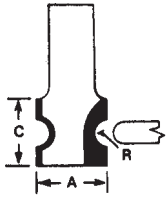

BULL NOSE RADIUS BITS

2 FLUTES

Order No.	A Cutting Diameter	Shank Diameter	C Cutting Length	R Radius	Material Thickness	Price
22-500	21/32	1/4	1/2	5/64	1/8	\$52.80
22-505	21/32	1/2	1/2	5/64	1/8	55.00
22-510	23/32	1/4	1/2	7/64	3/16	55.00
22-515	23/32	1/2	1/2	7/64	3/16	57.75
22-520	25/32	1/4	3/4	9/64	1/4	57.75
22-525	25/32	1/2	3/4	9/64	1/4	59.95
22-530	29/32	1/4	3/4	13/64	3/8	65.00
22-535	29/32	1/2	3/4	13/64	3/8	68.50
22-1433A	1-7/8	1/2	1-1/2	7/16	7/8	75.00
22-540	1-1/32	1/2	1	17/64	1/2	73.00
22-545	1-3/16	1/2	1-1/8	11/32	5/8	86.75
22-550	1-5/16	1/2	1-1/4	13/32	3/4	98.00
22-555	1-9/16	1/2	1-1/2	17/32	1	118.75
22-1434A	1-15/16	1/2	1-1/2	9/16	1-1/8	90.00
22-560	1-13/16	1/2	1-3/4	21/32	1-1/4	126.40
22-1436	2-7/16	1/2	1-7/8	3/4	1-1/2	140.00

BULL NOSE RADIUS BITS

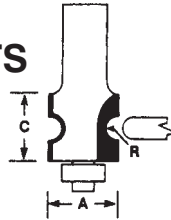

WITH BALL BEARING GUIDE - 2 FLUTES

Order No.	A Cutting Diameter	Shank Diameter	C Cutting Length	R Radius	Material Thickness	Price
22-600	21/32	1/4	1/2	5/64	1/8	\$61.60
22-605	21/32	1/2	1/2	5/64	1/8	63.80
22-610	23/32	1/4	1/2	7/64	3/16	63.80
22-615	23/32	1/2	1/2	7/64	3/16	66.55
22-620	25/32	1/4	3/4	9/64	1/4	66.55
22-625	25/32	1/2	3/4	9/64	1/4	68.75
22-630	29/32	1/4	3/4	13/64	3/8	73.00
22-635	29/32	1/2	3/4	13/64	3/8	76.50
22-640	1-1/32	1/2	1	17/64	1/2	81.00
22-645	1-3/16	1/2	1-1/8	11/32	5/8	94.75
22-650	1-5/16	1/2	1-1/4	13/32	3/4	106.50
22-655	1-9/16	1/2	1-1/2	17/32	1	127.40
22-660	1-13/16	1/2	1-3/4	21/32	1-1/4	135.00
12-145	Replacement Bearing Guide					4.50



TRADITIONAL EDGE BEADING BITS

WITH BALL BEARING GUIDE - 2 FLUTES

Order No.	R Radius	A Cutting Diameter	Shank Diameter	C Cutting Length	D Overall Length	E Bead	Price
22-3240	1/16	7/8	1/4	9/16	2	1/8	\$34.00
22-3242	1/16	7/8	1/2	9/46	2-1/4	1/8	35.00
22-700	1/8	25/32	1/4	1/2	1-1/2	1/4	41.20
22-705	1/8	25/32	1/2	1/2	2	1/4	42.35
22-3248	5/32	1	1/4	5/8	2-1/4	5/16	42.00
22-3250	5/32	1	1/2	5/8	2-1/4	5/16	44.00
22-710	3/16	29/32	1/4	5/8	1-5/8	3/8	49.00
22-715	3/16	2-9/32	1/2	5/8	2-1/8	3/8	48.15
22-720	1/4	1-1/32	1/4	3/4	1-3/4	1/2	51.15
22-725	1/4	1-1/32	1/2	3/4	2-1/4	1/2	53.35
22-3260	5/16	1-3/8	1/2	1	2-5/8	5/8	58.00
22-3262	3/8	1-1/2	1/2	1-1/8	3	3/4	62.00
12-145	Replacement Bearing Guide						4.50

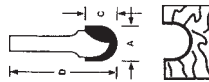

CORE BOX/ROUND NOSE BITS



CORE BOX - 2 FLUTES

Order No.	R Radius	A Cutting Diameter	Shank Diameter	C Cutting Length	D Overall Length	Price
19-100	1/16	1/8	1/4	3/16	1-3/4	\$27.50
19-105	3/32	3/16	1/4	3/16	1-3/4	27.50
19-110	1/8	1/4	1/4	3/16	1-3/4	27.50
19-115	3/16	3/8	1/4	3/8	1-3/4	29.65
19-120	3/16	3/8	1/2	3/8	2	34.65
19-125	1/4	1/2	1/4	1/2	1-3/4	30.25
19-130	1/4	1/2	1/2	1/2	2	35.25
19-135	5/16	5/8	1/4	1/2	1-3/4	31.35
19-140	5/16	5/8	1/2	1/2	2	40.15
19-145	3/8	3/4	1/4	5/8	2	32.45
19-150	3/8	3/4	1/2	5/8	2-1/4	42.35
19-155	7/16	7/8	1/4	5/8	2	44.00
19-160	7/16	7/8	1/2	5/8	2-1/4	52.80
19-165	1/2	1	1/4	5/8	2	50.60
19-170	1/2	1	1/2	5/8	2-1/4	60.50
19-175	5/8	1-1/4	1/2	3/4	2-3/4	88.00
19-180	3/4	1-1/4	1/2	7/8	2-7/8	110.00
19-185	7/8	1-3/4	1/2	1	3	137.50
19-190	1	2	1/2	1-1/8	3	165.00

ROUND NOSE- 2 FLUTES

Order No.	R Radius	A Cutting Diameter	Shank Diameter	C Cutting Length	D Overall Length	Price
19-1407	3/16	3/8	1/2	1	2-5/8	\$32.00
19-1408	1/4	1/2	1/2	1-1/4	2-7/8	34.00
19-1410	5/16	5/8	1/2	1-1/4	2-7/8	36.00
19-1411	3/8	3/4	1/2	1-1/4	2-7/8	42.00
19-1412	7/16	7/8	1/2	1-1/4	2-7/8	51.00
19-1413	1/2	1	1/2	1-1/4	2-7/8	53.00
19-1414	5/8	1-1/4	1/2	1-1/4	3	56.00
19-1415	3/4	1-1/2	1/2	1-1/4	3	73.00
19-1416	7/8	1-3/4	1/2	1-1/4	3	106.00
19-1417	1	2	1/2	1-1/4	3	110.00

CALL TOLL FREE 1-800-443-0992 • FAX TOLL FREE 1-888-728-8665
or visit our web site at www.ridgecarbide.com



LIBERTY LINE ROUTER BITS

TOP RATED BY FINE WOODWORKING MAGAZINE

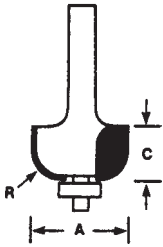

DROP LEAF TABLE SET

FOR 3/4" MATERIAL
2 PIECES 1/2" RADIUS COVE & ROUND OVER
24-185 1/4" SHANK
24-190 1/2" SHANK
\$79.95



COVE BITS

WITH BALL BEARING GUIDE - 2 FLUTES



DOUBLE FILLET COVE BITS

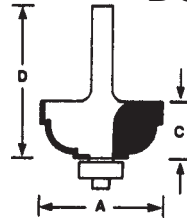

WITH BALL BEARING GUIDE - 2 FLUTES

Order No.	A Radius	Cutting Diameter	C Shank	D Cutting Length	Price
24-100	1/16	1/2	1/4	1/2	\$41.75
24-105	1/16	1/2	1/2	1/2	42.75
24-110	1/8	5/8	1/4	1/2	44.00
24-115	1/8	5/8	1/2	1/2	43.00
24-120	3/16	3/4	1/4	1/2	42.00
24-125	3/16	3/4	1/2	1/2	43.00
24-130	1/4	7/8	1/4	1/2	42.50
24-135	1/4	7/8	1/2	1/2	44.00
24-140	5/16	1	1/4	1/2	43.50
24-145	5/16	1	1/2	1/2	45.00
24-150	3/8	1-1/8	1/4	1/2	44.50
24-155	3/8	1-1/8	1/2	1/2	44.50
24-160	1/2	1-3/8	1/4	5/8	48.00
24-165	1/2	1-3/8	1/2	5/8	51.00
24-1806	5/8	1-3/4	1/2	3/4	60.00
24-1807	3/4	2	1/2	7/8	69.00
24-1810	1	2-1/2	1/2	1	98.00
12-140	3/8	Replacement Bearing Guide			5.00
12-145	1/2	Replacement Bearing Guide			4.50

Order No.	A Cutting Diameter	Shank Diameter	C Cutting Length	D Overall Length	Price
24-300	1-1/8	1/4	1/2	1-5/8	\$56.90
24-305	1-1/8	1/2	1/2	2	57.70
24-310	1-3/8	1/4	5/8	1-3/4	63.40
24-315	1-3/8	1/2	5/8	2-1/8	64.75
12-145		Replacement Bearing Guide			4.50



ROUNDING OVER COVE BITS

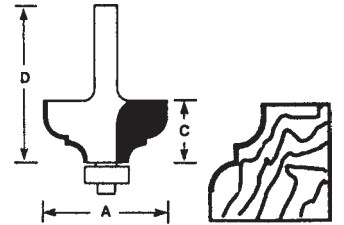

WITH BALL BEARING GUIDE - 2 FLUTES

COVE FILLET BITS

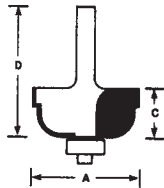

WITH BALL BEARING GUIDE - 2 FLUTES

Order No.	A Cutting Diameter	Shank Diameter	C Cutting Length	D Overall Length	Price
24-200	1-1/8	1/4	1/2	1-5/8	\$57.25
24-205	1-1/8	1/2	1/2	2	58.35
24-210	1-3/8	1/4	5/8	1-3/4	61.25
24-215	1-3/8	1/2	5/8	2-1/8	63.75
12-145		Replacement Bearing Guide			4.50

Order No.	A Cutting Diameter	Shank Diameter	C Cutting Length	D Overall Length	Price
23-500	1-1/8	1/4	1/2	1-5/8	\$51.20
23-505	1-1/8	1/2	1/2	2	52.30
23-510	1-3/8	1/4	11/16	1-3/4	53.95
23-515	1-3/8	1/2	11/16	2-1/8	55.60
12-145		Replacement Bearing Guide			4.50

WAVY EDGE FORM BITS

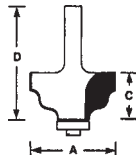

WITH BALL BEARING GUIDE - 2 FLUTES

Order No.	A Cutting Diameter	Shank Diameter	C Cutting Length	D Overall Length	Price
26-300	1-1/4	1/4	5/8	1-3/4	\$56.00
26-305	1-1/4	1/2	5/8	2-1/4	56.00
12-145		Replacement Bearing Guide			4.50



CLASSICAL BITS

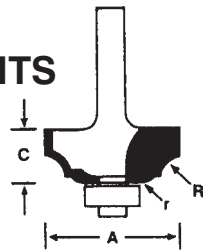

WITH BALL BEARING GUIDE - 2 FLUTES

Order No.	A Cutting Diameter	Shank Diameter	C Cutting Length	R Radius	r Radius	Price
25-200	1-1/4	1/4	1/2	3/16	3/16	\$57.25
25-205	1-1/4	1/2	1/2	3/16	3/16	59.45
25-210	1-1/2	1/4	5/8	1/4	3/16	65.10
25-215	1-1/2	1/2	5/8	1/4	3/16	67.30
12-145		Replacement Bearing Guide				4.50

CALL TOLL FREE 1-800-443-0992 • FAX TOLL FREE 1-888-728-8665
or visit our web site at www.ridgecarbide.com



LIBERTY LINE ROUTER BITS

TOP RATED BY FINE WOODWORKING MAGAZINE



CHAMFER BITS

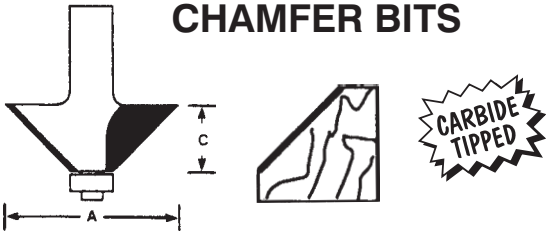

WITH BALL BEARING GUIDE - 2 FLUTES - 30° & 45° ANGLE

Order No.	A Cutting Diameter	Angle of Cut	Shank Diameter	C Cutting Length	Price
16-300	1-1/4	45°	1/4	7/16	\$36.30
16-305	1-1/4	45°	1/2	7/16	37.40
16-310	2	45°	1/2	13/16	112.20
16-315	2-1/2	45°	1/2	1-1/16	116.50
16-320	3	45°	1/2	1-1/4	181.50
16-325	1-3/4	30°	1/2	1-1/16	185.90
Replacement Bearing Guides					
12-140	For 1-1/4 Cutting Diameter Bits				5.00
12-145	For 2 & 2-1/2 Cutting Diameter Bits				4.50

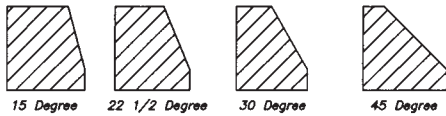

EDGE BEVEL BITS

WITH BALL BEARING GUIDES - 2 FLUTES

Order No.	Degree of Angle	Shank Diameter	Cutting Length	Cutting Height	Price
16-2308	30° ①	1/4	7/8	3/4	\$40.00
16-2325	15° ③	1/2	1	15/16	35.00
16-2307	22 1/2° ②	1/2	15/16	7/8	36.00
16-2309	30° ①	1/2	7/8	3/4	37.00
12-145	Replacement Bearing Guide				4.50

- ① Used for six side boxes
- ② Used for eight side boxes
- ③ Used for twelve side boxes

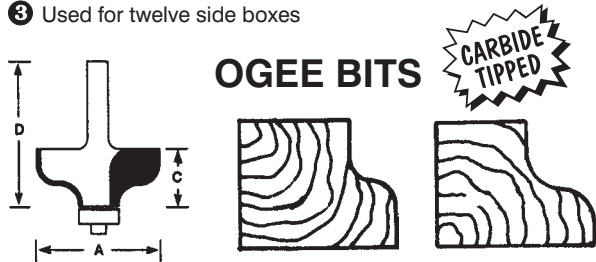

OGEE BITS

WITH BALL BEARING GUIDE - 2 FLUTES

Order No.	A Cutting Diameter	Shank Diameter	C Cutting Length	D Overall Length	Price
23-400	1-1/8	1/4	1/2	1-5/8	\$54.50
23-405	1-1/8	1/2	1/2	2	57.25
23-410	1-3/8	1/4	11/16	1-3/4	59.45
23-415	1-3/8	1/2	11/16	2-1/8	61.65
12-140	Replacement Bearing Guide				5.00

ROMAN OGEE BITS



WITH BALL BEARING GUIDE - 2 FLUTES

Order No.	Radius	A Cutting Diameter	Shank Diameter	C Cutting Length	Price
23-100	5/32	1	1/4	15/32	\$44.45
23-105	5/32	1	1/2	15/32	46.65
23-110	1/4	1-3/8	1/4	21/32	45.55
23-115	1/4	1-3/8	1/2	21/32	47.75
12-140	Replacement Bearing Guide				5.00



DOUBLE ROMAN OGEE BITS

WITH BALL BEARING GUIDE - 2 FLUTES

Order No.	A Cutting Diameter	Shank Diameter	C Cutting Length	D Overall Length	Price
23-200	1	1/4	5/8	1-3/4	\$49.65
23-205	1	1/2	5/8	2	53.85
23-210	1-3/8	1/4	3/4	1-7/8	55.05
23-215	1-3/8	1/2	3/4	2-1/4	58.25
12-140	Replacement Bearing Guide				5.00

OGEE FILLET BITS

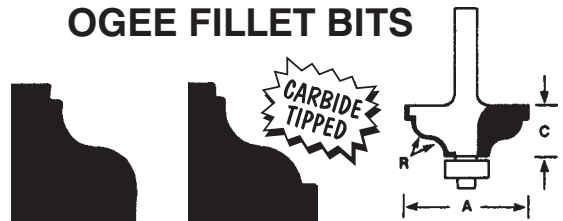

WITH BALL BEARING GUIDE - 2 FLUTES

Order No.	A Cutting Diameter	Shank Diameter	C Cutting Length	D Overall Length	Price
23-600	1-3/8	1/4	9/16	3/16	\$63.65
23-605	1-3/8	1/2	9/16	3/16	66.40
23-610	1-5/8	1/2	13/16	1/4	72.35
12-145	Replacement Bearing Guide				5.00

CALL TOLL FREE 1-800-443-0992 • FAX TOLL FREE 1-888-728-8665
or visit our web site at www.ridgecarbide.com



LIBERTY LINE ROUTER BITS

TOP RATED BY FINE WOODWORKING MAGAZINE



DOVETAIL BITS

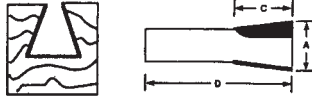

2 FLUTES

Order No.	Degree Each Side	A Cutting Diameter	Shank Diameter	C Cutting Length	D Overall Length	Price
18-100	9°	3/8	1/4	3/8	1-3/4	\$22.00
18-105	9°	3/8	1/2	3/8	2	23.10
18-110	14°	1/2	1/4	1/2	1-3/4	22.55
18-115	14°	1/2	1/2	1/2	2-1/8	25.30
18-120	7°	5/8	1/2	7/8	2-3/4	36.30
18-125	7°	3/4	1/2	7/8	2-1/2	28.50
18-130	7°	7/8	1/2	7/8	2-1/2	40.70
18-135	14°	1	1/2	1	2-1/2	41.80

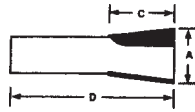

STAIR ROUTING BITS

7° ANGLE - 2 FLUTES

Order No.	Rotation	A Cutting Diameter	Shank Diameter	C Cutting Length	D Overall Length	Price
18-200	Right Hand	3/4	1/2	7/8	2-1/2	\$41.50
18-205	Left Hand	3/4	1/2	7/8	2-1/2	50.50
18-210	Right Hand	7/8	1/2	7/8	2-1/2	43.70
18-215	Left Hand	7/8	1/2	7/8	2-1/2	52.70
18-220	Right Hand	1	1/2	7/8	2-1/2	49.70
18-225	Left Hand	1	1/2	7/8	2-1/2	58.70

TRADITIONAL FILLET BITS

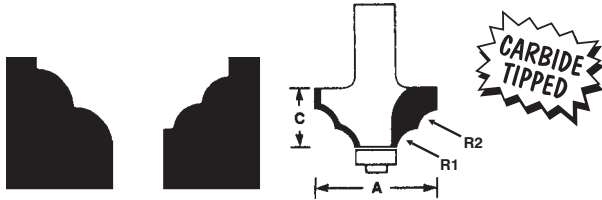

WITH BALL BEARING GUIDE - 2 FLUTES

Order No.	A Cutting Diameter	Shank Diameter	C Cutting Length	R1 Radius	R2 Radius	Price
26-200	1-1/8	1/4	9/16	5/32	5/32	\$60.50
26-205	1-1/8	1/2	9/16	5/32	5/32	61.60
26-210	1-3/8	1/4	11/16	7/32	7/32	64.90
26-215	1-3/8	1/2	11/16	7/32	7/32	66.00
26-220	1-1/2	1/4	3/4	1/4	1/4	82.50
26-225	1-1/2	1/2	3/4	1/4	1/4	83.60
26-230	1-3/4	1/2	7/8	1/4	3/8	88.00
26-235	1-3/4	1/2	7/8	3/8	1/4	100.00
12-145	Replacement Bearing Guide					4.50

"V" GROOVING BITS



90° INCLUDED ANGLE - 2 FLUTES

Order No.	A Cutting Diameter	Shank Diameter	C Cutting Length	D Overall Length	Price
20-100	3/8	1/4	1/2	1-3/4	\$28.00
20-105	3/8	1/2	1/2	2	29.40
20-110	1/2	1/4	1/2	1-3/4	31.35
20-115	1/2	1/2	1/2	2	35.25
20-120	5/8	1/4	1/2	1-7/8	43.45
20-125	5/8	1/2	1/2	2-1/2	48.00
20-130	3/4	1/4	5/8	2	41.15
20-135	3/4	1/2	5/8	2-1/4	55.75
20-140	7/8	1/4	5/8	2	61.05
20-145	7/8	1/2	5/8	2-1/4	63.20
20-150	1	1/4	5/8	2-1/4	66.00
20-155	1	1/2	5/8	2-1/2	71.50
20-160	1-1/4	1/2	3/4	2-3/4	75.00
20-165	1-1/2	1/2	1	3	82.00

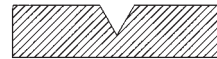

60° INCLUDED ANGLE - FOR SIGN CARVING

Order No.	A Cutting Diameter	Shank Diameter	C Cutting Length	D Overall Length	Price
20-1540	1/4	1/4	7/32	1-1/2	\$20.00
20-1541	1/4	1/4	7/32	2	22.00
20-1550	1/2	1/4	7/16	2	26.00
20-1560	1/2	1/2	7/16	2-1/4	27.00

DISH & DRAINBOARD BITS

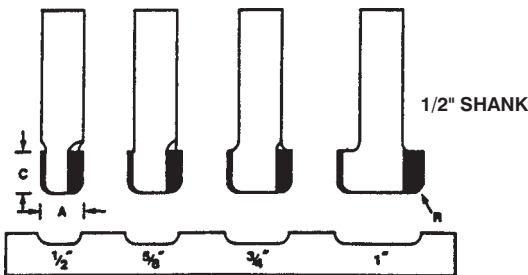

FOR ROUTING DRAINBOARD DESIGNS IN FOUNTAINHEAD™ COUNTERTOPS

Order No.	A Cutting Diameter	C Cutting Length	R Radius	Price
30-050	1/2	1/2	1/8	\$38.00
30-052	5/8	1/2	1/8	40.00
30-054	3/4	1/2	1/8	42.00
30-056	1	1/2	1/8	53.00

CALL TOLL FREE 1-800-443-0992 • FAX TOLL FREE 1-888-728-8665
or visit our web site at www.ridgecarbide.com



LIBERTY LINE ROUTER BITS

TOP RATED BY FINE WOODWORKING MAGAZINE



2 WING COMPLETE ASSEMBLIES

INCLUDES: Cutter, Arbor, and Bearing Guide

Order No.	Kerf	Shank Diameter	Price
29-200	1/16	1/4	\$28.00
29-205	1/16	1/2	28.00
29-210	.075	1/4	28.00
29-215	.075	1/2	28.00
29-220	.080	1/4	28.00
29-225	.080	1/2	28.00
29-230	3/32	1/4	28.60
29-235	3/32	1/2	28.60
29-240	1/8	1/4	28.60
29-245	1/8	1/2	28.60
29-250	3/16	1/4	30.25
29-255	3/16	1/2	30.25
29-260	1/4	1/4	30.25
29-265	1/4	1/2	30.25

2 WING SLOTTING CUTTERS

- CUTTERS ONLY -

2" DIAMETER - 5/16" HOLE

Order No.	Kerf	Price
29-100	1/16	\$16.80
29-105	.075	16.80
29-110	.080	16.80
29-115	3/32	17.60
29-120	1/8	17.60
29-125	3/16	19.25
29-130	1/4	19.25

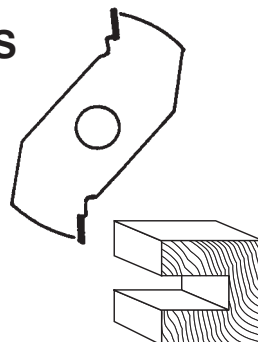

3 WING SLOTTING CUTTERS

- CUTTERS ONLY -

2" DIAMETER - 5/16" HOLE

Order No.	Kerf	Price
29-300	1/16	\$20.00
29-305	5/64	21.00
29-310	3/32	21.50
29-315	1/8	22.50
29-320	5/32	23.50
29-325	3/16	24.00
29-330	1/4	24.50

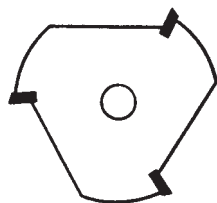

3 WING COMPLETE ASSEMBLIES

INCLUDES: Cutter, Arbor, and Bearing Guide

Order No.	Kerf	Shank Diameter	Price
29-400	1/16	1/4	\$30.00
29-405	1/16	1/2	30.00
29-410	5/64	1/4	31.50
29-415	5/64	1/2	31.50
29-420	3/32	1/4	32.00
29-425	3/32	1/2	32.00
29-430	1/8	1/4	33.00
29-435	1/8	1/2	33.00
*29-440	5/32	1/4	34.00
*29-445	5/32	1/2	34.00
29-450	3/16	1/4	34.50
29-455	3/16	1/2	34.50
29-460	1/4	1/4	35.00
29-465	1/4	1/2	35.00

* For Biscuit Jointing



FOR BISCUIT JOINTING

0 - 10 - 20 BISCUITS

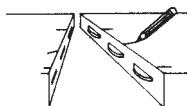

USE COMP #

* 29-440 1/4" SHANK

* 29-445 1/2" SHANK

BEARING CONVERSION KIT

TWO PIECE SET TO VARY DEPTH OF CUT

COMP # 47729 \$22.00

4 WING COMPLETE ASSEMBLIES

INCLUDES: Cutter, Arbor, and Bearing Guide

Order No.	Kerf	Shank Diameter	Price
29-600	1/16	1/4	\$40.15
29-605	1/16	1/2	40.15
29-610	.075	1/4	40.15
29-615	.075	1/2	40.15
29-620	.080	1/4	40.15
29-625	.080	1/2	40.15
29-630	3/32	1/4	41.80
29-635	3/32	1/2	41.80
29-640	1/8	1/4	41.80
29-645	1/8	1/2	41.80
29-650	3/16	1/4	43.45
29-655	3/16	1/2	43.45
29-660	1/4	1/4	45.65
29-665	1/4	1/2	45.65

4 WING SLOTTING CUTTERS

- CUTTERS ONLY -

2" DIAMETER - 5/16" HOLE

Order No.	Kerf	Price
29-500	1/16	\$29.15
29-505	.075	29.15
29-510	.080	29.15
29-515	3/32	30.80
29-520	1/8	30.80
29-525	3/16	32.45
29-530	1/4	64.65

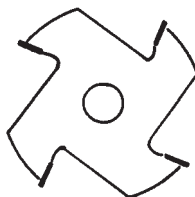

CALL TOLL FREE 1-800-443-0992 • FAX TOLL FREE 1-888-728-8665
or visit our web site at www.ridgecarbide.com



LIBERTY LINE ROUTER BITS

TOP RATED BY FINE WOODWORKING MAGAZINE

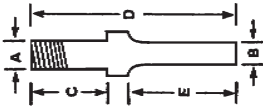

ROUTER CUTTER ARBORS

WITH NUT AND WASHER

Order No.	A Arbor Diameter	B Shank Diameter	C Arbor Length	D Overall Length	E Shank Length	Price
13-100	5/16	1/4	7/8	2-3/8	1-1/4	\$5.50
13-105	5/16	3/8	7/8	2-3/8	1-1/4	5.50
13-110	5/16	1/2	7/8	2-3/8	1-1/2	5.50
13-115	5/16	1/4	11/16	2-1/8	1	5.50
13-120	5/16	1/2	11/16	2	1-3/8	5.50
13-125	1/4	1/4	7/8	2-3/8	1-1/4	5.50
13-130	1/4	1/4	1/4	1-3/4	1-3/8	5.50
13-135	1/4	1/2	1/4	2-3/8	2-1/8	5.50
13-140	1/4	1/4	1	2-1/4	1-1/8	6.00
13-145	1/4	1/2	1	2-1/2	1-1/2	6.00
13-150	5/16	1/4	1/4	1-3/4	1-3/8	6.00
13-155	5/16	1/2	1/4	1-3/4	1-1/2	6.00
13-160	5/16	1/2	1-1/2	3	1-1/2	9.25

- SPECIAL ARBORS MADE TO ORDER -

HIGH-PERFORMANCE DELRIN® PLASTIC SLEEVE BEARINGS

A synthetic plastic material which will not mark material being cut. Applications include solid surface material and all plastics.



NOT RECOMMENDED FOR WOOD

Order No.	A Inside Diameter	B Outside Diameter	Degrees	Price
12-305	3/16	1/2	---	\$12.00
12-307	3/16	1/2	---	18.00*
12-340	1/4	3/4	---	20.00
12-342	1/4	3/4	---	23.00*
12-360	5/16	7/8	---	23.00
12-362	5/16	7/8	---	28.00*
12-395	1/4	3/4	5°	21.00
12-397	1/4	3/4	---	21.00*
12-405	1/4	3/4	10°	21.00
12-425	1/4	15/16	5°	21.00
12-427	1/4	15/16	---	26.00*
12-485	1/4	7/8	5°	21.00
12-487	1/4	7/8	5°	26.00*
12-497	1/4	7/8	15°	21.00
12-510	1/4	7/8	10°	21.00
12-512	1/4	7/8	10°	26.00*
12-515	1/4	1	5°	26.00*
12-517	1/4	1	7°	26.00
12-520	1/4	1	5°	21.00
12-522	1/4	1	---	26.00*
12-525	1/4	1	10°	21.00
12-527	1/4	1	10°	26.00*
12-540	1/4	1	30°	22.00

*Denotes bearing guide assemblies, which include: bushed bearing with plastic retainer bearing, high hat steel bushing and screw.

ADAPTER BUSHINGS

STEEL ADAPTER BUSHINGS

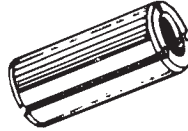

Used to reduce the collet size for smaller diameter shank bits. Used for router bits, end mills, drill bits, and dremel bits. Never exceed the recommended RPM of the cutting tool.

Order No.	OD	ID	Price
271	1/4	1/8	\$15.00
272	1/4	3/16	15.00
273	1/2	1/8	15.00
274	1/2	3/16	15.00
275	1/2	1/4	15.00
276	1/2	5/16	15.00
277	1/2	3/8	15.00

BEARING LOCK COLLARS

Retaining collars used when bearings are added to shanks of router bits for following templates.

Order No.	Shank Diameter	Outside Diameter	Price
LC-1/4	1/4	7/16	\$6.00
LC-1/2	1/2	11/16	6.00

STEEL BEARING GUIDES

SPECIAL SIZES MADE TO ORDER



Order No.	A Inside Diameter	B Outside Diameter	Price
12-100	5/16	1/2	\$10.00
12-105	5/16	5/8	9.00
12-110	5/16	3/4	12.00
12-115	1/4	3/8	9.00
12-120	1/4	1/2	9.00
12-125	1/8	1/4	9.00
12-130	1/8	1/2	8.00
12-135	3/16	3/8	5.00
12-140	1/8	3/8	5.00
12-145	3/16	1/2	4.50
12-150	5/16	.865	5.50
12-155	5/16	.945	9.00
12-160	1/4	5/8	5.00
12-165	1/4	3/4	5.50
12-170	1/2	1-1/8	9.00
12-173	1/2	3/4	15.00
12-175	1/2	1	24.50
12-B7	3/16	5/8	10.00
12-B8	3/16	3/4	12.00
12-B12	3/8	7/8	11.00
12-B14	3/16	11/16	10.00
12-B15	3/16	13/16	13.00
12-B16	1/2	1-1/4	19.00
12-B17	1/2	1-3/8	19.00
12-B18	1/2	1-1/2	19.00
12-B20	1/4	7/8	12.00
12-B24	1/2	1-7/8	21.00
12-B25	5/16	1-1/8	17.00
12-B26	5/16	1-3/8	17.00

SHAPER CUTTER TO ROUTER ADAPTOR

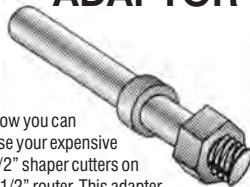

Now you can use your expensive 1/2" shaper cutters on a 1/2" router. This adaptor is to be used with a variable speed router or with a combination router speed control and a router. Use with speeds of about 10,000 RPM. Not to be used at full speeds on a router.

Item # 282

\$24.95

CALL TOLL FREE 1-800-443-0992 • FAX TOLL FREE 1-888-728-8665
or visit our web site at www.ridgecarbide.com



EDGE FORMING BITS

FOR SOLID SURFACE OR WOOD - NOT TO SCALE



#60-101 MERRICK

1/2 Shank, 3 Diameter,
1-1/8 Cutting Length,
2 Flutes
\$205.00

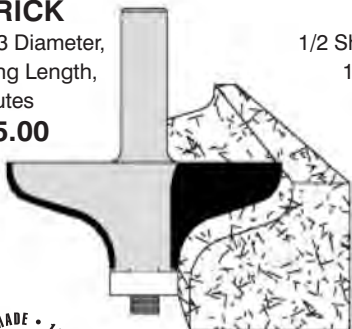

#60-102 BALDWIN

1/2 Shank, 2-5/8 Diameter,
1 Cutting Length,
2 Flutes
\$200.00



#60-103 HILLSIDE

1/2 Shank, 2-3/4 Diameter,
1-1/4 Cutting Length,
2 Flutes
\$245.00



#60-104 BAYSIDE

1/2 Shank, 3 Diameter,
1-3/8 Cutting Length,
2 Flutes
\$255.00

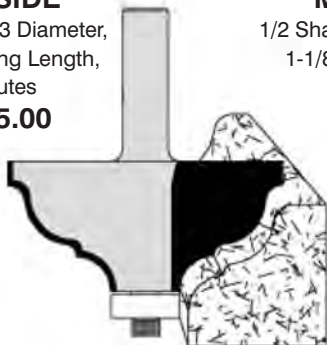

#60-105 MONTAUK

1/2 Shank, 2-1/2 Diameter,
1-1/8 Cutting Length,
2 Flutes
\$190.00

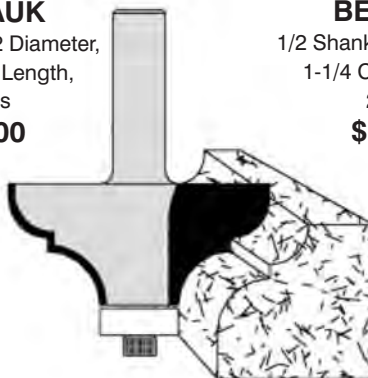

#60-106 BELMONT

1/2 Shank, 2-1/4 Diameter,
1-1/4 Cutting Length,
2 Flutes
\$190.00

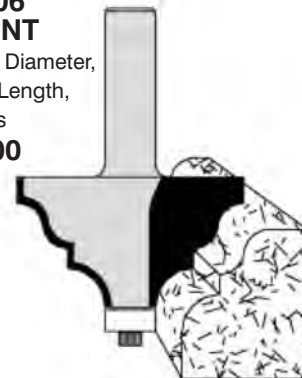

#60-107 BARKER

1/2 Shank, 2-3/4 Diameter,
1-1/2 Cutting Length,
2 Flutes
\$230.00

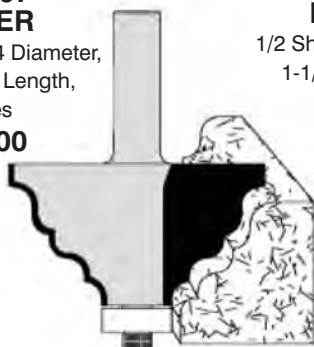

#60-108 HAMPTON

1/2 Shank, 2-1/4 Diameter,
1-1/4 Cutting Length,
2 Flutes
\$180.00

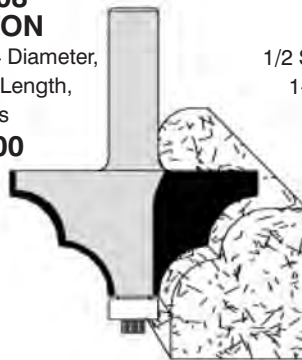

#60-109 HILLCREST

1/2 Shank, 2-3/4 Diameter,
1-5/8 Cutting Length,
2 Flutes
\$205.00

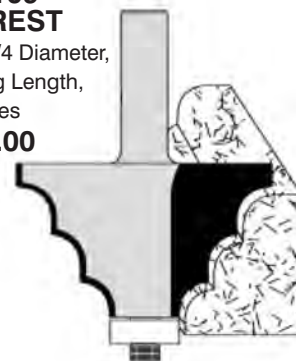

CALL TOLL FREE 1-800-443-0992 • FAX TOLL FREE 1-888-728-8665
or visit our web site at www.ridgecarbide.com



EDGE FORMING BITS

FOR SOLID SURFACE OR WOOD - NOT TO SCALE



**#60-110
OLYMPIA**
1/2 Shank, 1-1/2 Diameter,
2 Cutting Length,
2 Flutes
\$210.00

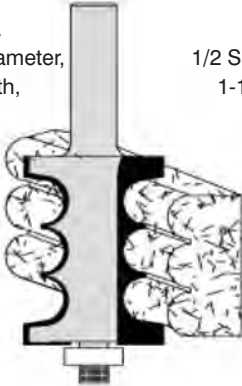

**#60-111
HUNTER**
1/2 Shank, 2-1/2 Diameter,
1-1/2 Cutting Length,
2 Flutes
\$205.00

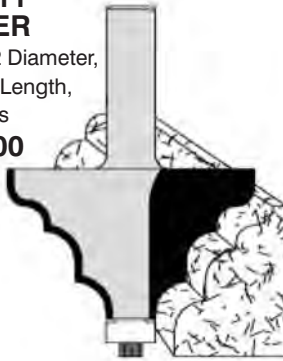

**#60-112
HUDSON**
1/2 Shank, 3 Diameter,
1-1/8 Cutting Length,
2 Flutes
\$265.00

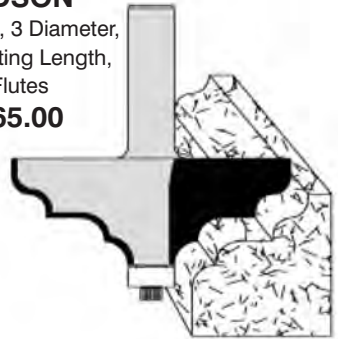

**#60-113
CLIFTON**
1/2 Shank, 1-1/2 Diameter,
1-3/4 Cutting Length
\$200.00

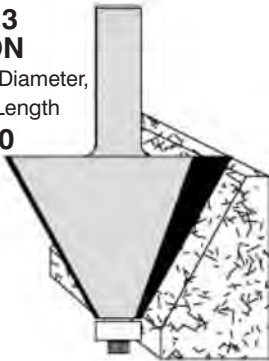

**#60-114
HAMILTON**
1/2 Shank, 3 Diameter,
1-1/3 Cutting Length,
2 Flutes
\$255.00

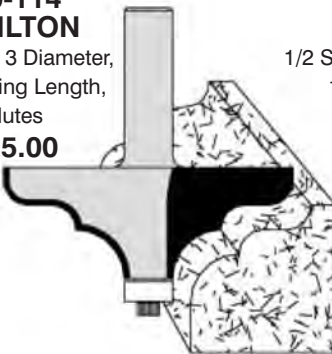

**#60-115
HANOVER**
1/2 Shank, 3-1/8 Diameter,
1 Cutting Length,
2 Flutes
\$255.00

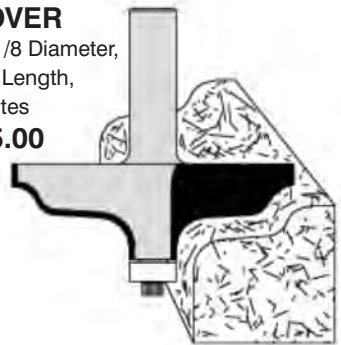

**#60-116
BAXTER**
1/2 Shank, 2-1/2 Diameter,
7/8 Cutting Length,
2 Flutes
\$210.00

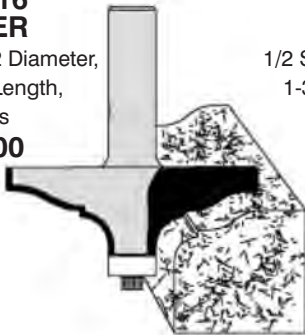

**#60-117
BUTLER**
1/2 Shank, 2-1/2 Diameter,
1-3/16 Cutting Length,
2 Flutes
\$210.00

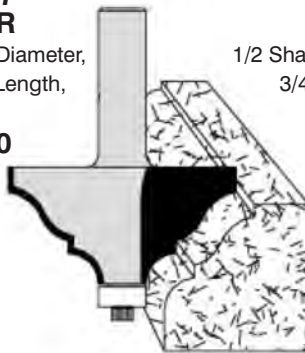

**#60-118
HAMLET**
1/2 Shank, 1-11/16 Diameter,
3/4 Cutting Length,
2 Flutes
\$160.00

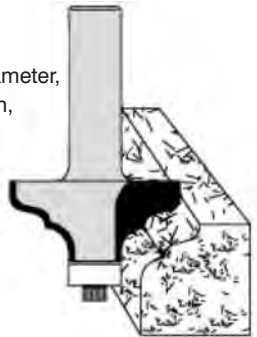

**#60-119
BRADLEY**
1/2 Shank, 2-1/4 Diameter,
1-3/8 Cutting Length,
2 Flutes
\$215.00

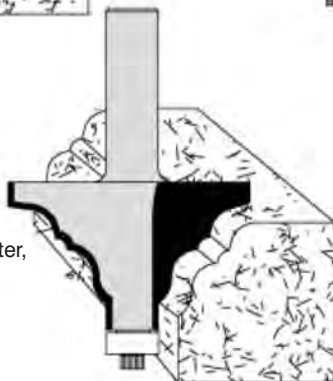

**#60-120
OAKDALE**
1/2 Shank, 1-1/2 Diameter,
2 Cutting Length,
2 Flutes
\$210.00

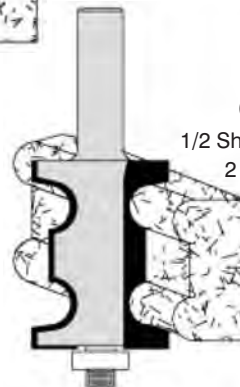

CALL TOLL FREE 1-800-443-0992 • FAX TOLL FREE 1-888-728-8665
or visit our web site at www.ridgecarbide.com





EDGE FORMING BITS

FOR SOLID SURFACE OR WOOD - NOT TO SCALE



**#60-121
ONTARIO**
1/2 Shank, 1-1/2 Diameter,
2 Cutting Length,
2 Flutes
\$220.00

**#60-122
N. OCEAN**
1/2 Shank, 1-3/8 Diameter,
3/4 Cutting Length,
2 Flutes
\$145.00



**#60-123
S. OCEAN**
1/2 Shank, 1-3/4 Diameter,
3/4 Cutting Length,
2 Flutes
\$160.00



**#60-124
WALTON**
1/2 Shank, 1-3/4 Diameter,
1-1/4 Cutting Length,
2 Flutes
\$165.00



**#60-125
BENTLEY**
1/2 Shank, 2 Diameter,
1-1/8 Cutting Length,
2 Flutes
\$200.00

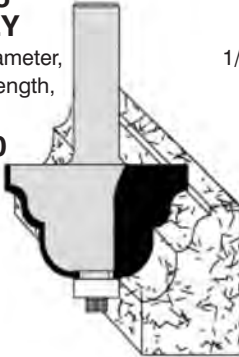

**#60-126
HAMBURG**
1/2 Shank, 1-3/4 Diameter,
1/2 Cutting Length,
2 Flutes
\$160.00



**#60-127
MANOR**
1/2 Shank, 2-1/4 Diameter,
1 Cutting Length,
2 Flutes
\$187.00



**#60-128
BEVERLY**
1/2 Shank, 1-3/4 Diameter,
1-1/4 Cutting Length,
2 Flutes
\$195.00



**#60-129
BOSWELL**
1/2 Shank, 1-1/2 Diameter,
3/4 Cutting Length,
2 Flutes
\$185.00

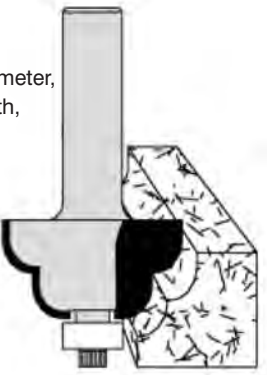

**#60-130
BANGOR**
1/2 Shank, 2-1/2 Diameter,
1-1/4 Cutting Length,
2 Flutes
\$195.00

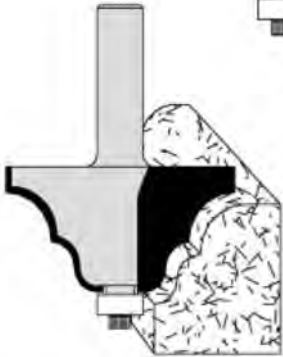

**#60-131
BROOKS**
1/2 Shank, 2 Diameter,
7/8 Cutting Length,
2 Flutes
\$160.00



CALL TOLL FREE 1-800-443-0992 • FAX TOLL FREE 1-888-728-8665
or visit our web site at www.ridgecarbide.com



EDGE FORMING BITS

FOR SOLID SURFACE OR WOOD - NOT TO SCALE

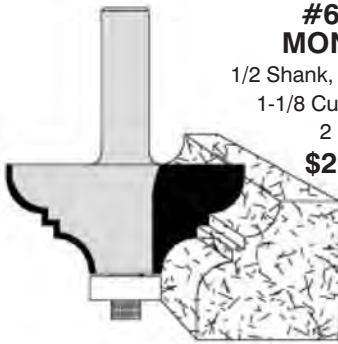

**#60-132
MONARCH**
1/2 Shank, 2-1/2 Diameter,
1-1/8 Cutting Length,
2 Flutes
\$200.00

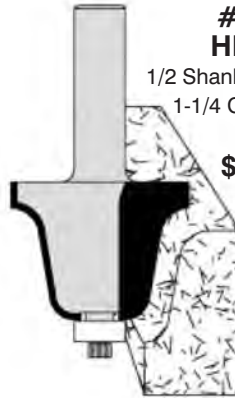

**#60-133
HIALEAH**
1/2 Shank, 1-3/4 Diameter,
1-1/4 Cutting Length,
2 Flutes
\$170.00



**#60-134
SPANISH**
1/2 Shank, 1-3/4 Diameter,
5/8 Cutting Length,
2 Flutes
\$175.00

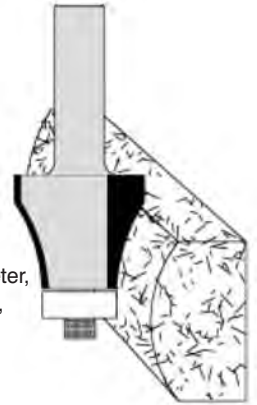

**#60-135
GLENDALE**
1/2 Shank, 1-5/16 Diameter,
1-1/16 Cutting Length,
2 Flutes
\$175.00



We now offer this popular door edge profile as a standard item!

CONESTOGA DOOR EDGE BIT

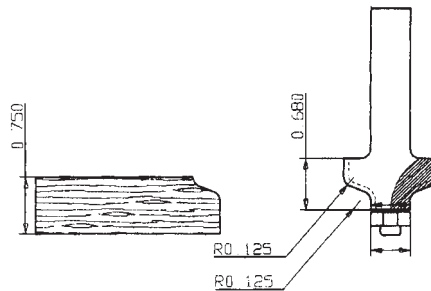

WITH 1/2" BEARING GUIDE

Order No.	A Cutting Diameter	Shank Diameter	C Cutting Length	D Overall Length	Price
CDE-4	1-3/16	1/4	11/16	2-11/16	\$95.00
CDE-8	1-3/16	1/2	11/16	2-11/16	98.00
12-145		Replacement Bearing			3.70

CALL TOLL FREE 1-800-443-0992 • FAX TOLL FREE 1-888-728-8665
or visit our web site at www.ridgecarbide.com



EDGE FORMING ROUTER BITS



TOOLS SHOWN NOT TO SCALE
EDGE DETAILS

**CARBIDE
TIPPED**

CNC
H-1215
\$81.00

CNC
H-1619
\$69.00

CNC
H-1703
\$89.00

CNC
H-1702
\$89.00

CNC
H-29
\$73.00

CNC
H-1694
\$132.00

CNC
H-1685
\$161.00

CNC
H-1650P
\$115.00

CNC
H-2013
\$69.00

CNC
WINDOW SILL BIT
H-2011
\$81.00

CNC
H-1619-C1C
\$86.00

CNC
H-1215-C3S
\$88.00

CNC
H-2012
\$81.00

CNC
H-1154
\$81.00

CNC
H-1104
\$88.00

CNC
WINDOW SILL BIT
H-17C
\$86.00



2 FLUTE-1/2" SHANK ONLY

Order No.	Inside Diameter	Outside Diameter
H-1104	3/4	2-1/8
H-1154	3/4	2
H-1215	1/2	1-25/32
H-1215-C3S	3/4	2
H-1619	1/2	1-3/4
H-1619-C1C	3/4	2
H-1650P	3/4	1-13/16
H-1685	3/4	2-3/4
H-1694	3/4	2-3/8
H-17C	3/4	1-5/8
H-1702	1/2	1-3/4
H-1703	1/2	1-3/4
H-2011	3/4	1-1/2
H-2012	1/2	1-5/8
H-2013	1/2	1-5/16
H-29	5/8	1-1/2

CALL TOLL FREE 1-800-443-0992 • FAX TOLL FREE 1-888-728-8665
or visit our web site at www.ridgecarbide.com



SPECIALTY ROUTER SHAPER BITS



CARBIDE TIPPED

EXTENDED QUARTER ROUND

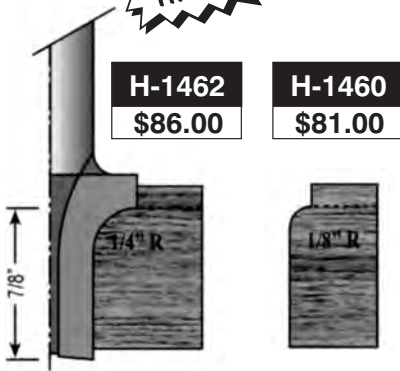

H-1462
\$86.00

H-1460
\$81.00

2 FLUTE - 1/2" SHANK

Order No.	Inside Diameter	Outside Diameter
H-1460	1/2	3/4
H-1462	1/2	1
H-1464	1/2	1-1/4
H-1466	1/2	1-1/2

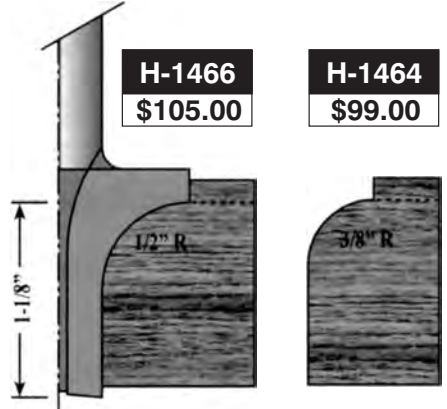

H-1466
\$105.00

H-1464
\$99.00



SHORTENED HALF ROUND

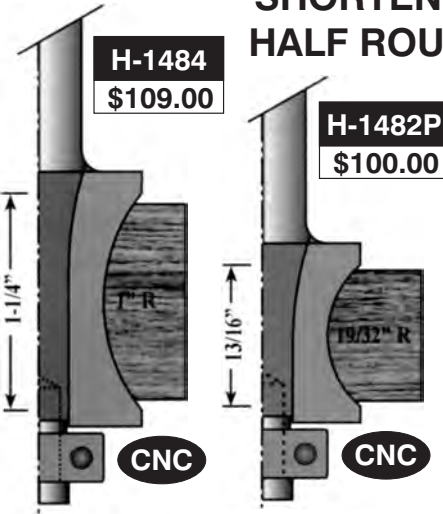

H-1484
\$109.00

H-1482P
\$100.00

2 FLUTE - 1/2" SHANK

Order No.	Inside Diameter	Outside Diameter
H-1482P	3/4	1-1/8
H-1484	3/4	1-3/16
H-1492	3/4	1
H-1494	3/4	1

DOUBLE EASING BIT

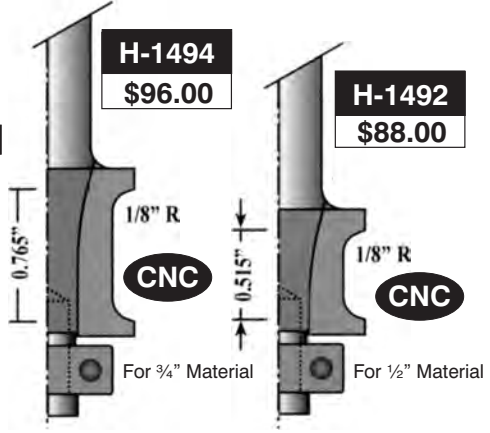

H-1494
\$96.00

H-1492
\$88.00

LARGE 120° V-GROOVE (INCLUDED ANGLE)

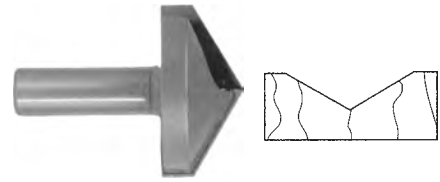

1/2" SHANK				
Order No.	Large Diameter	Cel	Overall Length	Price
22-1340	1-3/4	1/2	2-1/4	\$75.00

LARGE ROUND NOSE BIT

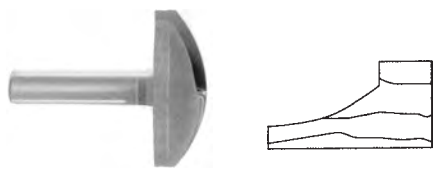

1/2" SHANK			
Order No.	Radius	Large Diameter	Price
19-2250	1-3/4	2-1/4	\$80.00



CNC

"CNC" Bearing System

The bearing and post are removable so cuts can be produced on a CNC.

All stock router bits are only available with a 1/2" shank. Routers with a 3/4" I.D. have larger bearings that strengthen the tools for industrial applications.



SPECIALTY ROUTER SHAPER BITS



TOOLS SHOWN NOT TO SCALE

CHAMFER BEVEL ANGLE BITS

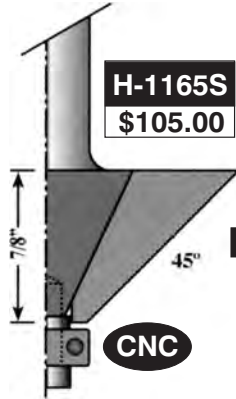
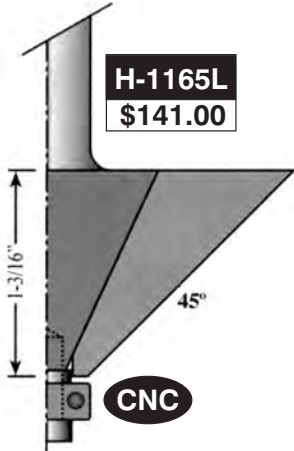

2 FLUTE - 1/2" SHANK

Order No.	Inside Diameter	Outside Diameter
H-1165L	1/2	2-13/16
H-1165S	1/2	2-7/32
H-1166-22.5	1/2	1-1/2

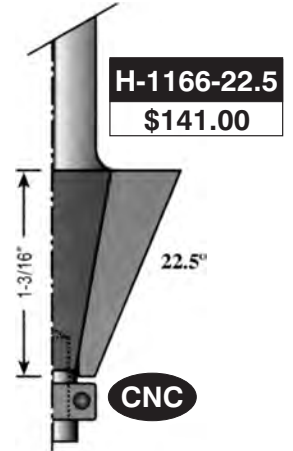

STRAIGHT T&G SET



FLOORING SET

H-T&G-C
\$99.00

H-T&G-S
\$99.00

H-725-S
\$155.00

H-725-C
\$155.00

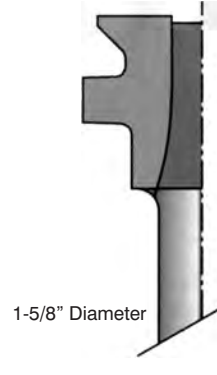
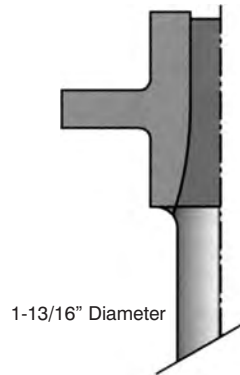
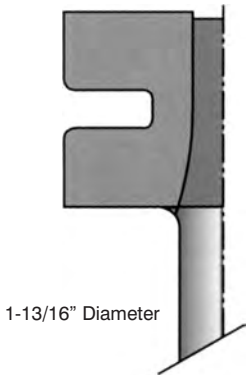

H-T&G SET
\$186.00

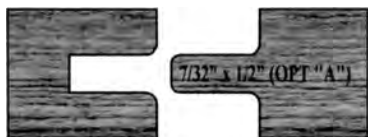

2 FLUTE - 1/2" SHANK

H-725 SET
\$293.00



CALL TOLL FREE 1-800-443-0992 • FAX TOLL FREE 1-888-728-8665
or visit our web site at www.ridgecarbide.com



SPECIALTY ROUTER SHAPER BITS



V-PANEL SET

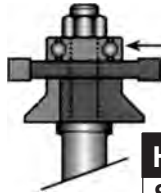
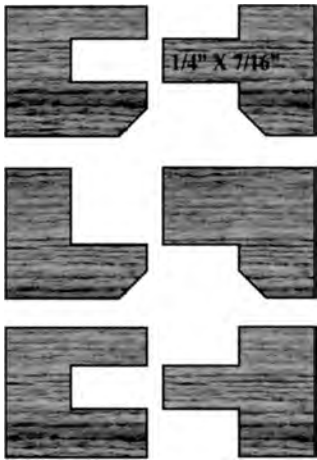

The bearing can be replaced with an H-A3 if a cutter is needed.
\$31.00

H-729-S
\$109.00

H-729 SET
\$206.00

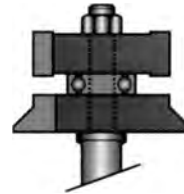

H-729-C
\$109.00

2 FLUTE - 1/2" SHANK

Order No.	Inside Diameter	Outside Diameter
H-729-S	22mm	1-3/4
H-729-C	22mm	2-1/4



WINDOW SASH SET

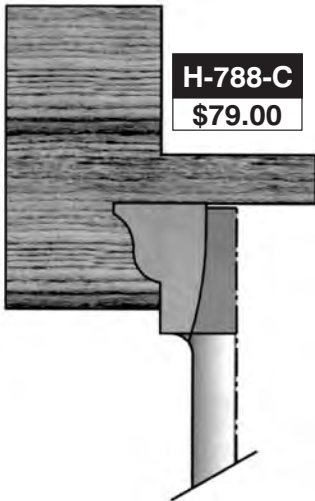

H-788-C
\$79.00

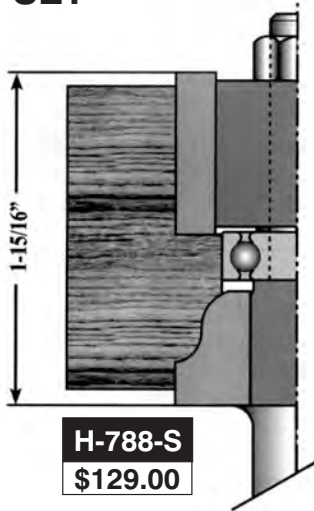

H-788-S
\$129.00

V-GROOVE SET

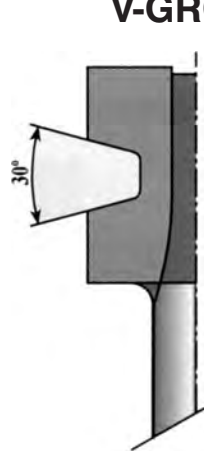

H-742-C
\$88.00

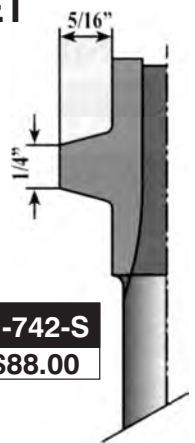

H-742-S
\$88.00



H-742 SET
\$165.00

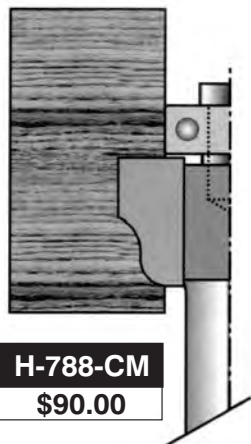

H-788-CM
\$90.00

H-788 SET 2
S + C
\$179.00

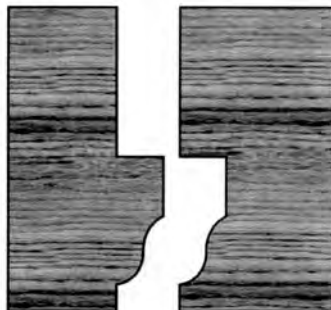

H-788 SET 3
S + C + CM
\$285.00

2 FLUTE - 1/2" SHANK

Order No.	Diameter
H-788-C	1-13/32
H-788-S	1-13/32
H-788-CM	1-13/32
H-742-C	1-1/4
H-742-S	1-1/4



.3/4" to 1-1/8" Material

CALL TOLL FREE 1-800-443-0992 • FAX TOLL FREE 1-888-728-8665
or visit our web site at www.ridgecarbide.com



SPECIALTY ROUTER BITS



TOOLS SHOWN NOT TO SCALE

FINGER JOINT



H-3080M
\$115.00

GLUE JOINT

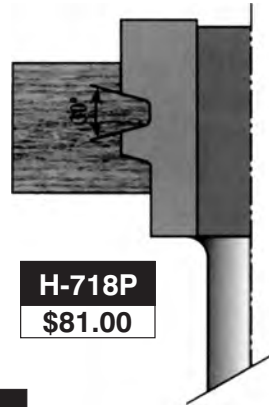

H-718P
\$81.00

CARBIDE TIPPED

2 FLUTE-1/2" SHANK ONLY

Order No.	Outside Diameter
H-3080M	1-3/8
H-718P	1-1/2
H-748M	2
H-747M	2-5/16
H-757	2-1/16



LOCK-MITER

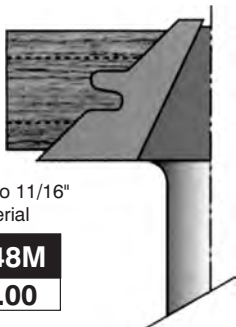

For 3/8" to 11/16"
Material

H-748M
\$90.00

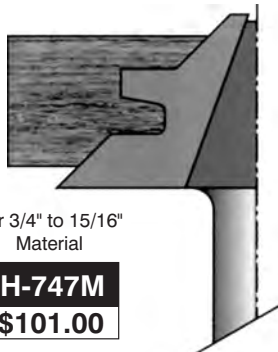

For 3/4" to 15/16"
Material

H-747M
\$101.00

When properly positioned, these router bits will cut "A" and "B" matching joints without changing the vertical adjustment of the fence.

Both "A" and "B" are run flat on the router table. Part "B" is run again on the table saw to cut the groove.

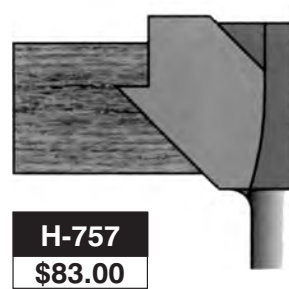

H-757
\$83.00

**CALL TOLL FREE 1-800-443-0992 • FAX TOLL FREE 1-888-728-8665
or visit our web site at www.ridgecarbide.com**



SPECIALTY ROUTER BITS



TOOLS SHOWN NOT TO SCALE

REVERSIBLES



2 FLUTE-1/2" SHANK ONLY

Order No.	Inside Diameter	Outside Diameter
H-178	3/4	1-1/2
H-182	3/4	2
H-1880A	3/4	3-1/16
H-1884A	3/4	2
H-1880B	3/4	1-9/16

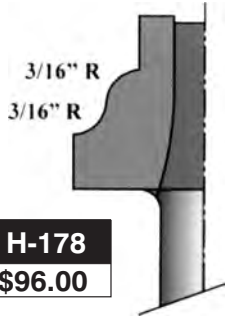

H-178
\$96.00

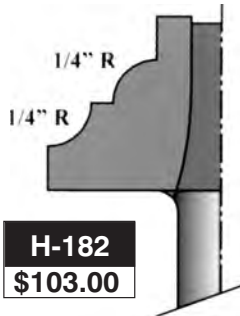

H-182
\$103.00



HAND RAILS FOR 6010 HAND RAIL

Custom Handrail Bit
Made To Order
Fax Drawing or
Send Wood Sample

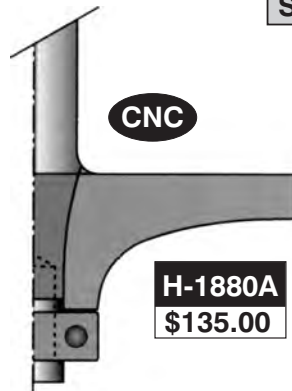
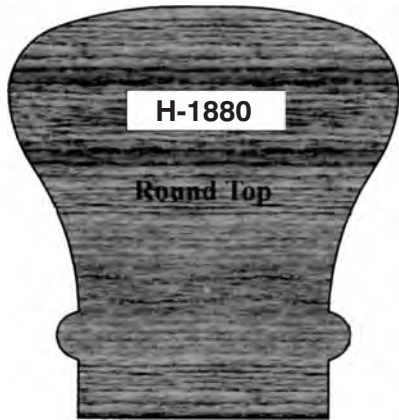

The H-1880B is used for the bottom cuts on both the H-1880 and H-1884.

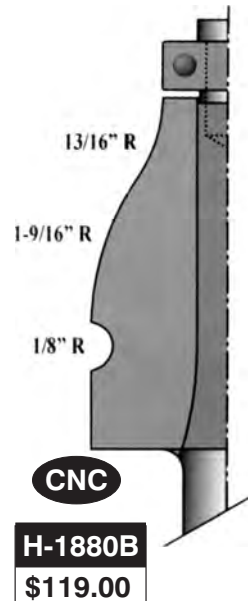
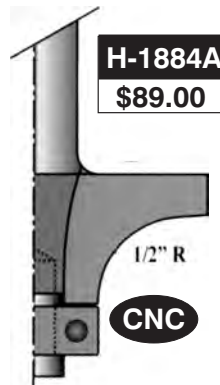
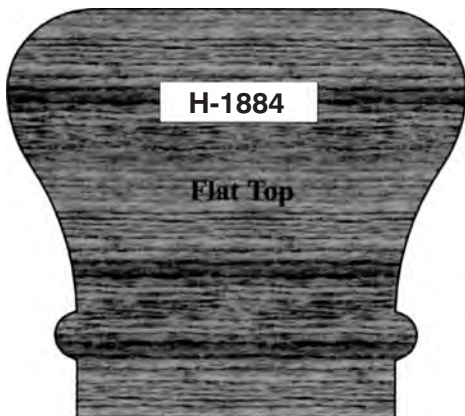

CALL TOLL FREE 1-800-443-0992 • FAX TOLL FREE 1-888-728-8665
or visit our web site at www.ridgecarbide.com



ROUTERS - CABINET DOOR COPE & STICK



TOOLS SHOWN NOT TO SCALE

Custom
Cope & Stick Sets
Made To Order

CABINET DOOR SETS

2 FLUTE - 1/2" SHANK

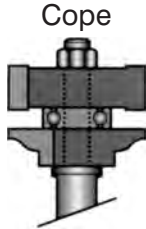

Cope

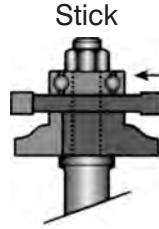

Stick

The bearings can be replaced with an H-A3 if a cutter is needed. \$33.00

Your
Choice
\$189.00
2 PC. SET

**CARBIDE
TIPPED**

All cope and sticks have a 1-3/4" outside diameter and a 22MM inside diameter.

Each cope & stick set will produce the three following wood samples: cabinet door, glass door, and shaker door.

H-48-SC

2 PC.
SET

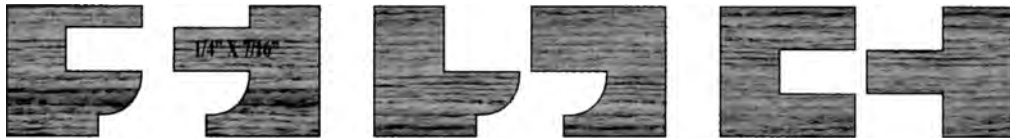

H-49-SC

2 PC.
SET



H-750-SC

2 PC.
SET

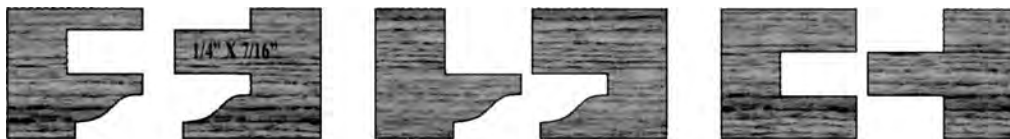

H-752-SC

2 PC.
SET

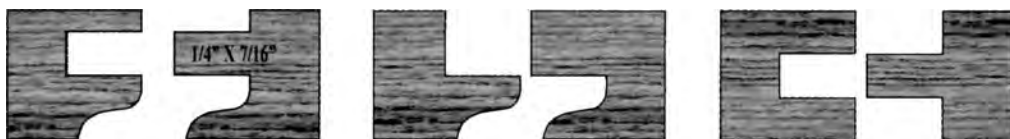

**CALL TOLL FREE 1-800-443-0992 • FAX TOLL FREE 1-888-728-8665
or visit our web site at www.ridgecarbide.com**



ROUTERS - INTERIOR & EXTERIOR DOOR SETS



TOOLS SHOWN NOT TO SCALE



INTERIOR/EXTERIOR DOOR SETS

INTERIOR DOOR SET (1-3/8" MATERIAL)

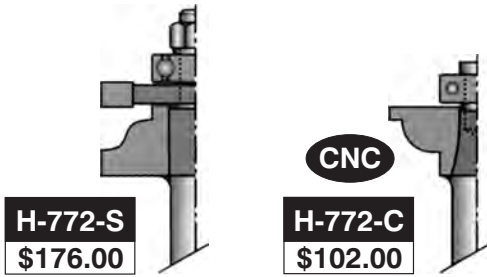

The 1/4" groove cutter is available by itself. The order number is H-77-14. \$33.00

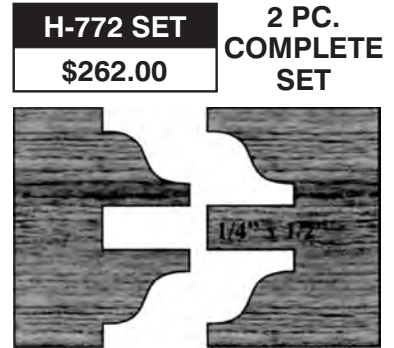

EXTERIOR DOOR SET (1-3/4" MATERIAL)

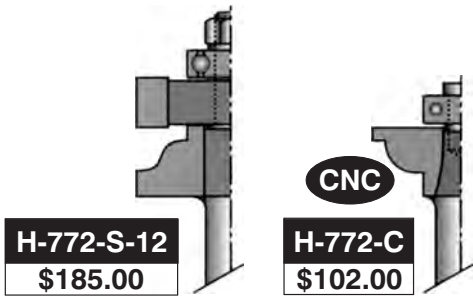

The 1/2" groove cutter is available by itself. The order number is H-77-12. \$38.00

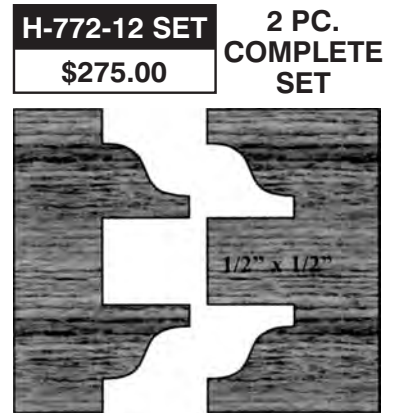

GLASS DOOR SET (1-3/8" TO 1-3/4" MATERIAL)

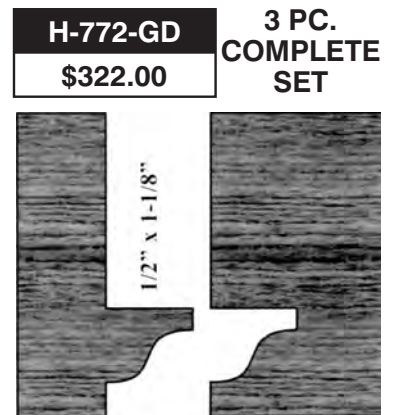

2 FLUTE		
Order No.	Inside Diameter	Outside Diameter
H-772-S	22MM	1-7/8
H-772-C	3/4	1-3/4
H-772-S12	22MM	1-7/8
H-77-GD	3/4	1-3/4

CALL TOLL FREE 1-800-443-0992 • FAX TOLL FREE 1-888-728-8665
or visit our web site at www.ridgecarbide.com



ROUTERS - INTERIOR & EXTERIOR DOOR SETS



TOOLS SHOWN NOT TO SCALE



INTERIOR/EXTERIOR DOOR SETS

INTERIOR DOOR SET (1-3/8" MATERIAL)



H-771-S
\$176.00

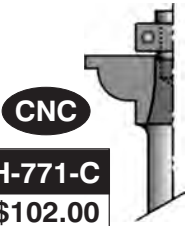

H-771-C
\$102.00

CNC

The 1/4" groove cutter is available by itself. The order number is H-77-14. \$33.00

H-771 SET
\$262.00

2 PC. COMPLETE SET



EXTERIOR DOOR SET (1-3/4" MATERIAL)

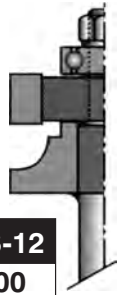

H-771-S-12
\$185.00

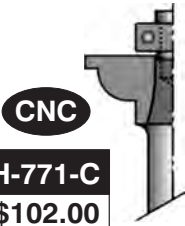

H-771-C
\$102.00

CNC

The 1/2" groove cutter is available by itself. The order number is H-77-12. \$38.00

H-771-12 SET
\$271.00

2 PC. COMPLETE SET



GLASS DOOR SET (1-3/8" TO 1-3/4" MATERIAL)



H-771-S
\$176.00



H-77-GD
\$63.00

CNC



H-771-C
\$102.00

CNC

H-771-GD
\$322.00

3 PC. COMPLETE SET

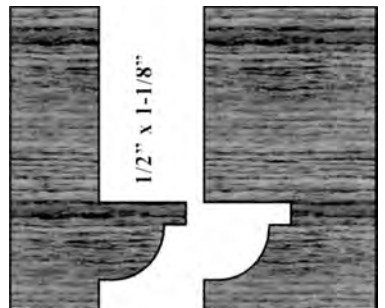

2 FLUTE

Order No.	Inside Diameter	Outside Diameter
H-771-S	22MM	1-7/8
H-771-C	3/4	1-3/4
H-771-S12	22MM	1-7/8
H-77-GD	3/4	1-3/4

CALL TOLL FREE 1-800-443-0992 • FAX TOLL FREE 1-888-728-8665
or visit our web site at www.ridgecarbide.com



CABINET DOOR ROUTER BITS



TOOLS SHOWN NOT TO SCALE

**CARBIDE
TIPPED**

RAISED PANELS FOR 5/8" AND 3/4" MATERIAL

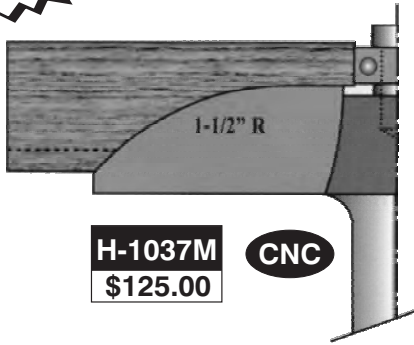

H-1037M
\$125.00 **CNC**

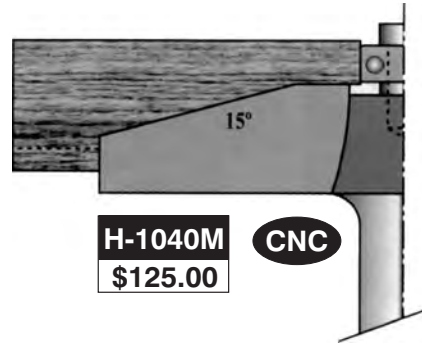

H-1040M
\$125.00 **CNC**

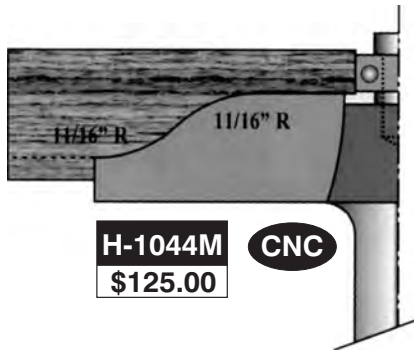

H-1044M
\$125.00 **CNC**

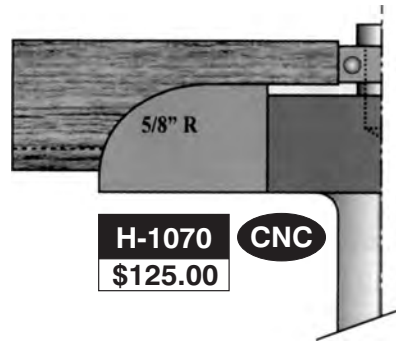

H-1070
\$125.00 **CNC**

PARTIAL DOUBLE RAISED PANEL

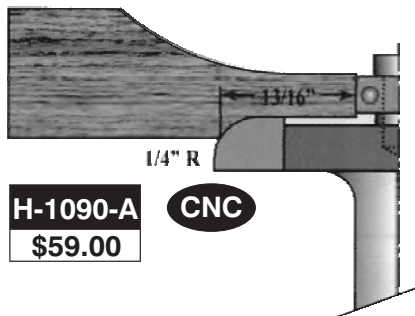

H-1090-A
\$59.00 **CNC**

2 FLUTE-1/2" SHANK ONLY

Order No.	Inside Diameter	Outside Diameter
H-1037M	1/2	3-1/2
H-1040M	1/2	3-1/2
H-1044M	1/2	3-1/2
H-1070	1/2	3-1/4
H-1090A	1/2	2-1/8

Custom Router Bits Made To Order

CALL TOLL FREE 1-800-443-0992 • FAX TOLL FREE 1-888-728-8665
or visit our web site at www.ridgecarbide.com



CABINET DOOR ROUTER BITS



TOOLS SHOWN NOT TO SCALE

RAISED PANELS WITH BACK CUT

**CARBIDE
TIPPED**

2 FLUTE-1/2" SHANK ONLY

Order No.	Inside Diameter	Outside Diameter
H-1037MB	5/8	3-1/2
H-1040MB	5/8	3-1/2

Both router bits are
Multi-pass Application.

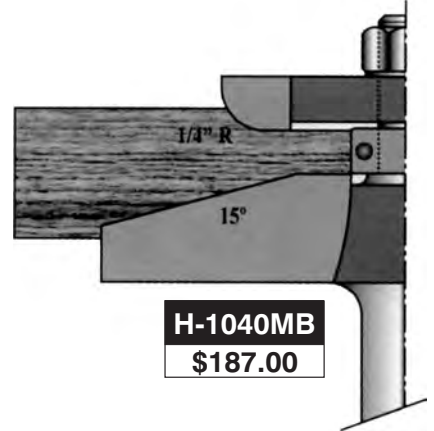
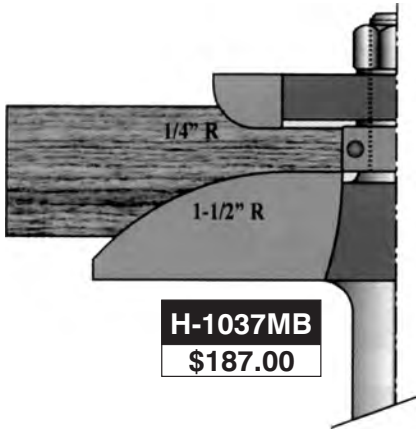

VERTICAL RAISED PANELS FOR 5/8" AND 3/4" MATERIAL

2 FLUTE-1/2" SHANK ONLY

Order No.	Diameter
H-1038V	1-1/8
H-1037MV	1-1/4

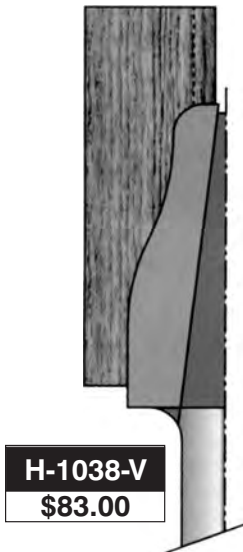

**CARBIDE
TIPPED**

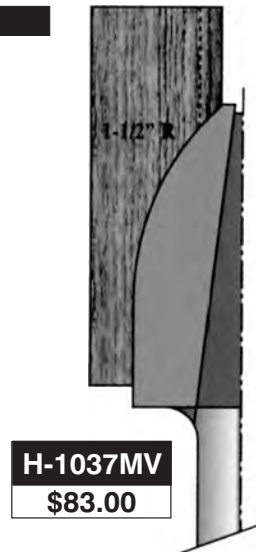

**CALL TOLL FREE 1-800-443-0992 • FAX TOLL FREE 1-888-728-8665
or visit our web site at www.ridgecarbide.com**



BAND SAW BLADES



CARBON WOOD PRODUCTION & GENERAL PURPOSE

Ideal for wood production cutting as well as short production/maintenance applications using low alloy steel & non-ferrous metals. These carbon steel blades are manufactured from a single piece of high carbon steel with individually hardened tooth tips. The flexible back makes them more fatigue resistant. These blades are a perfect, all around band saw blade for all woodworking shops. Carbide tipped blades are readily available.

		NUMBER OF TEETH & BLADE TYPE																							
		4	6	8	10	12	14	18	24	8	10	12	14	18	24	32	2	3	4	6	2	3	4	6	
INCHES		STANDARD RAKER								STANDARD WAVY								HOOK				SKIP			
1/4" x .025"				▼	▼	▼	▼	▼	▼							▼			▼	▼			▼	▼	
3/8" x .025"				▼	▼	▼	▼	▼	▼							▼			▼	▼			▼	▼	
1/2" x .025"		▼	▼	▼	▼		▼	▼	▼		▼		▼	▼	▼	▼			▼	▼			▼	▼	
5/8" x .032"				▼	▼		▼	▼	▼		▼		▼	▼	▼	▼			▼	▼			▼	▼	
3/4" x .032"			▼	▼	▼	▼	▼	▼	▼	▼	▼	▼	▼	▼	▼	▼			▼	▼			▼	▼	
1" x .035"			▼	▼	▼		▼	▼	▼		▼		▼	▼	▼	▼	▼	▼	▼	▼	▼	▼	▼	▼	

**Custom Size
Band Saws
Made To Order**

HEF CARBON HARD EDGE, FLEXIBLE BACK		Weld to length pricing						
Band Width (Thickness)	Length - Up To	1/4" (.025")	3/8" (.025")	1/2" (.025")	5/8" (.032")	3/4" (.032")	1" (.035")	1-1/4" (.035")
7"	NBS107014 \$14.15	NBS107038 \$14.60	NBS107012 \$14.80	NBS107058 \$16.25	NBS107034 \$17.25	NBS107010 \$20.50	NBS1070125 \$35.60	
7'6"	NBS107514 14.55	NBS107538 15.00	NBS107512 15.25	NBS107558 16.50	NBS107534 17.75	NBS107510 21.25	NBS1075125 37.25	
8"	NBS108014 14.95	NBS108038 15.50	NBS108012 15.70	NBS108058 17.00	NBS108034 18.25	NBS108010 22.25	NBS1080125 38.90	
8'6"	NBS108514 15.35	NBS108538 15.95	NBS108512 16.25	NBS108558 17.60	NBS108534 18.95	NBS108510 22.95	NBS1085125 40.55	
9"	NBS109014 15.75	NBS109038 16.30	NBS109012 16.75	NBS109058 18.25	NBS109034 19.50	NBS109010 23.75	NBS1090125 42.20	
9'6"	NBS109514 16.25	NBS109538 16.75	NBS109512 17.00	NBS109558 18.75	NBS109534 20.25	NBS109510 24.75	NBS1095125 43.85	
10'	NBS110014 16.55	NBS110038 17.25	NBS110012 17.50	NBS110558 19.25	NBS110034 20.75	NBS110010 25.50	NBS1100125 45.50	
10'6"	NBS110514 16.95	NBS110538 17.75	NBS110512 17.95	NBS110558 19.75	NBS110534 21.25	NBS110510 26.50	NBS1105125 47.15	
11'	NBS111014 17.35	NBS111038 18.00	NBS111012 18.35	NBS111058 20.25	NBS111034 21.95	NBS111010 27.25	NBS1110125 48.80	
11'6"	NBS111514 17.75	NBS111538 18.50	NBS111512 18.80	NBS111558 20.75	NBS111534 22.50	NBS111510 28.00	NBS1115125 50.45	
12"	NBS112014 18.25	NBS112038 18.95	NBS112012 19.25	NBS112058 21.25	NBS112034 23.25	NBS112010 28.95	NBS1120125 52.10	
12'6"	NBS112514 18.55	NBS112538 19.35	NBS112512 19.75	NBS112558 21.75	NBS112534 23.75	NBS112510 29.75	NBS1125125 53.75	
13"	NBS113014 18.95	NBS113038 19.75	NBS113012 20.25	NBS113058 22.25	NBS113034 24.25	NBS113010 30.50	NBS1130125 55.40	
13'6"	NBS113514 19.35	NBS113538 20.25	NBS113512 20.65	NBS113558 22.85	NBS113534 24.95	NBS113510 31.50	NBS1135125 57.05	
14"	NBS114014 19.75	NBS1140.8 20.75	NBS114012 21.00	NBS114058 23.25	NBS114034 25.50	NBS114010 32.25	NBS1140125 58.70	
14'6"	NBS114514 20.25	NBS114538 21.00	NBS114512 21.50	NBS114558 23.75	NBS114534 26.00	NBS114510 33.00	NBS1145125 60.35	
15"	NBS115014 20.55	NBS115038 21.50	NBS115012 22.00	NBS115058 24.50	NBS115034 26.75	NBS115010 34.00	NBS1150125 61.95	
15'6"	NBS115514 20.95	NBS115538 21.95	NBS115512 22.50	NBS115558 25.00	NBS115534 27.50	NBS115510 34.75	NBS1155125 63.65	
16"	NBS116014 21.35	NBS116038 22.50	NBS116012 2.95	NBS116058 25.50	NBS116034 27.95	NBS116010 35.75	NBS1160125 65.30	
16'6"	NBS116514 21.75	NBS116538 22.75	NBS116512 23.25	NBS116558 25.95	NBS116534 28.50	NBS116510 36.50	NBS1165125 66.95	
17"	NBS117014 22.25	NBS117038 23.25	NBS117012 23.75	NBS117058 26.25	NBS117034 29.25	NBS117010 37.25	NBS1170125 68.60	
17'6"	NBS117514 22.55	NBS117538 23.75	NBS117512 24.25	NBS117558 27.00	NBS117534 29.75	NBS117510 38.25	NBS1175125 70.25	
18"	NBS118014 22.95	NBS118038 24.25	NBS118012 24.75	NBS118058 27.75	NBS118034 30.50	NBS118010 38.95	NBS1180125 71.90	
18'6"	NBS118514 23.50	NBS118538 24.50	NBS118512 25.00	NBS118558 28.00	NBS118534 31.00	NBS118510 39.95	NBS1185125 73.55	
19"	NBS119014 23.75	NBS119038 24.95	NBS119012 25.50	NBS119058 28.50	NBS119034 31.75	NBS119010 40.75	NBS1190125 75.20	
19'6"	NBS119514 24.25	NBS119538 25.50	NBS119512 26.00	NBS119558 29.00	NBS119534 32.25	NBS119510 41.50	NBS1195125 76.85	
20"	NBS120014 24.75	NBS120038 25.75	NBS120012 26.50	NBS120058 28.00	NBS120034 32.75	NBS120010 42.95	NBS1200125 78.50	
20'6"	NBS120514 24.95	NBS120538 26.25	NBS120512 27.00	NBS120558 30.25	NBS120534 33.50	NBS120510 43.50	NBS1205125 80.15	



AT-A-GLANCE

- Flexible backs are fatigue-resistant
- Individually hardened teeth
- Can be run at speeds up to 15,000 SFM (Surface Feet Per Minute)
- Low cost-per-blade/low cost-per-cut in wood. Higher cost-per-cut in metal

APPLICATIONS

- Wood
- Plastic
- Cork
- Composition Board
- Plywood
- Aluminum
- Non-ferrous metals
- Low alloy steel

**CALL TOLL FREE 1-800-443-0992 • FAX TOLL FREE 1-888-728-8665
or visit our web site at www.ridgecarbide.com**



RADIUS CUTTERS

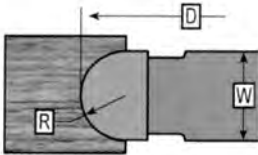

CONVEX RADIUS SHAPER



AVAILABLE BEARINGS

C-885	2 1/4" x 3/4" BORE	\$77.00
C-887	2 3/4" x 1" BORE	82.00
C-891	2 3/4" x 1 1/4" BORE	91.00

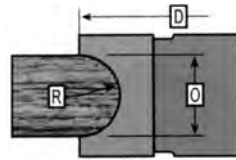

CONCAVE RADIUS SHAPER



AVAILABLE BEARINGS

C-885	2 1/4" x 3/4" BORE	\$77.00
C-887	2 3/4" x 1" BORE	82.00
C-891	2 3/4" x 1 1/4" BORE	91.00

3 WING - CARBIDE TIPPED

Order No.	R Radius	W Width	Outside Diameters		Price
			3/4" Arbor	1" & 1 1/4" Arbor	
K-1400	1/8	1/4	2-1/2	3	\$136.00
K-1401	3/16	3/8	2-5/8	3-1/8	141.00
K-1402	1/4	1/2	2-3/4	3-1/4	157.00
K-1403	5/16	5/8	2-7/8	3-3/8	172.00
K-1404	3/8	3/4	3	3-1/2	188.00
K-1405	7/16	7/8	3-1/8	3-5/8	211.00
K-1406	1/2	1	3-1/4	3-3/4	234.00
K-1407	5/8	1-1/4	3-1/2	4	289.00
K-1408	3/4	1-1/2	3-3/4	4-1/4	329.00
K-1409	1	2	4-1/4	4-3/4	389.00

3 WING - CARBIDE TIPPED

Order No.	R Radius	O Opening	Outside Diameters		Price
			3/4" Arbor	1" & 1 1/4" Arbor	
K-1420	1/8	1/4	2-1/2	3	\$153.00
K-1421	3/16	3/8	2-5/8	3-1/8	169.00
K-1422	1/4	1/2	2-3/4	3-1/4	188.00
K-1423	5/16	5/8	2-7/8	3-3/8	207.00
K-1424	3/8	3/4	3	3-1/2	225.00
K-1425	7/16	7/8	3-1/8	3-5/8	256.00
K-1426	1/2	1	3-1/4	3-3/4	278.00
K-1426-9/16R	9/16	1-1/8	3-3/8	3-7/8	286.00
K-1427	5/8	1-1/4	3-1/2	4	350.00
K-1428	3/4	1-1/2	3-3/4	4-1/4	387.00
K-1429	1	2	4-1/4	4-3/4	468.00



QUARTER ROUND CONCAVE RADIUS SHAPER

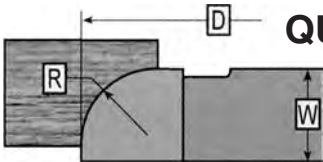
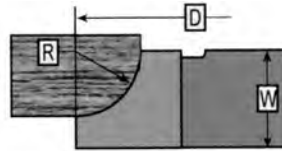

QUARTER ROUND CONVEX RADIUS SHAPER



AVAILABLE BEARINGS

C-885	2 1/4" x 3/4" BORE	\$77.00
C-887	2 3/4" x 1" BORE	82.00
C-891	2 3/4" x 1 1/4" BORE	91.00

3 WING - CARBIDE TIPPED

Order No.	R Radius	W Width	Outside Diameters		Price
			3/4" Arbor	1" & 1 1/4" Arbor	
K-1430	1/8	3/8	2-1/2	3	\$147.00
K-1430-FU	1/8	3/8	2-1/2	3	147.00
K-1431	3/16	3/8	2-5/8	3-1/8	161.00
K-1432	1/4	1/2	2-3/4	3-1/4	167.00
K-1432-FU	1/4	1/2	2-3/4	3-1/4	167.00
K-1433	5/16	5/8	2-7/8	3-3/8	175.00
K-1434	3/8	5/8	3	3-1/2	190.00
K-1434-FU	3/8	5/8	3	3-1/2	190.00
K-1435	7/16	3/4	3-1/8	3-5/8	215.00
K-1436	1/2	3/4	3-1/4	3-3/4	236.00
K-1436-FU	1/2	3/4	3-1/4	3-3/4	236.00
K-1437	5/8	7/8	3-1/2	4	256.00
K-1438	3/4	1	3-3/4	4-1/4	273.00
K-1439	1	1-1/8	4-1/4	4-3/4	305.00
K-1439-1/4	1-1/4	1-3/8	4-3/4	5-1/4	372.00
K-1439-1/2	1-1/2	1-5/8	5-1/4	5-3/4	435.00
*K-1439-2	2	2-1/2	6-1/2	7	760.00

• "FU" indicates tool in face-up position. The diagram is in a standard face-down position.
* Bearing sizes for part number K-1436-2 are 2 1/2" (3/4" bore) and 3" (1" & 1 1/4" bore).

AVAILABLE BEARINGS

C-885	2 1/4" x 3/4" BORE	\$77.00
C-887	2 3/4" x 1" BORE	82.00
C-891	2 3/4" x 1 1/4" BORE	91.00

3 WING - CARBIDE TIPPED

Order No.	R Radius	W Width	Outside Diameters		Price
			3/4" Arbor	1" & 1 1/4" Arbor	
K-1410	1/8	3/8	2-1/2	3	\$151.00
K-1411	3/16	3/8	2-5/8	3-1/8	167.00
K-1412	1/4	1/2	2-3/4	3-1/4	181.00
K-1413	5/16	5/8	2-7/8	3-3/8	198.00
K-1414	3/8	5/8	3	3-1/2	217.00
K-1415	7/16	3/4	3-1/8	3-5/8	230.00
K-1416	1/2	3/4	3-1/4	3-3/4	239.00
K-1417	5/8	7/8	3-1/2	4	260.00
K-1418	3/4	1	3-3/4	4-1/4	290.00
K-1419	1	1-1/8	4-1/4	4-3/4	320.00
K-1419-1 1/4	1-1/4	1-3/8	4-3/4	5-1/4	380.00
K-1419-1 1/2	1-1/2	1-5/8	5-1/4	5-3/4	418.00

CALL TOLL FREE 1-800-443-0992 • FAX TOLL FREE 1-888-728-8665
or visit our web site at www.ridgecarbide.com



RADIUS CUTTERS



SHORTENED HALF ROUND SHAPER

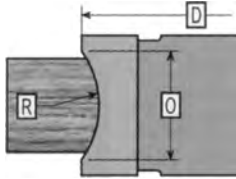

3 WING - CARBIDE TIPPED

Order No.	R Radius	O Opening	Outside Diameters		Price
			3/4" Arbor	1" & 1 1/4" Arbor	
K-1480	1/4	7/16	2-5/8	3-1/8	\$226.00
K-1481P	7/16	11/16	2-5/8	3-1/8	238.00
K-1482P	9/16	13/16	2-5/8	3-1/8	270.00
K-1483P	7/8	1-1/16	2-5/8	3-1/8	295.00
K-1484	1	1-1/4	2-11/16	3-3/16	352.00
K-1485	1-1/4	1-5/8	2-3/4	3-1/4	391.00
K-1486	1-3/4	1-7/8	2-3/4	3-1/4	419.00

EXTENDED QUARTER ROUND RADIUS SHAPER

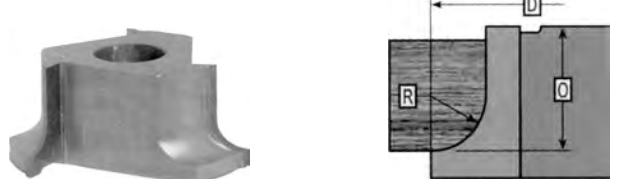

3 WING - CARBIDE TIPPED

Order No.	R Radius	O Opening	Outside Diameters		Price
			3/4" Arbor	1" & 1 1/4" Arbor	
K-1460	1/8	7/8	2-1/2	3	\$252.00
K-1462	1/4	7/8	2-3/4	3-1/4	268.00
K-1464	3/8	1-1/8	3	3-1/2	315.00
K-1466	1/2	1-1/8	3-1/4	3-3/4	348.00
K-1468	3/4	1-5/8	3-3/4	4-1/4	405.00

DOUBLE EASING SHAPER

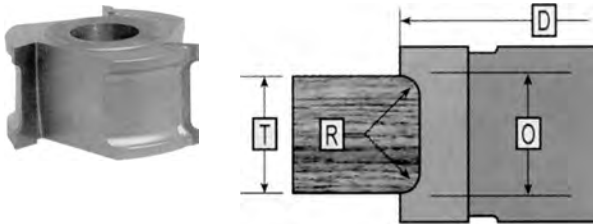

3 WING - CARBIDE TIPPED

Order No.	R Radius	O Opening	M Material Thickness	Outside Diameters		Price
				3/4" Arbor	1" & 1 1/4" Arbor	
K-1491	1/8	25/64	3/8	2-1/2	3	\$157.00
K-1492	1/8	33/64	1/2	2-1/2	3	171.00
K-1494	1/8	49/64	3/4	2-1/2	3	202.00
K-1495	1/8	1-1/64	1	2-1/2	3	217.00

AVAILABLE BEARINGS

C-885	2 1/4" x 3/4" BORE	\$77.00
C-887	2 3/4" x 1" BORE	82.00
C-891	2 3/4" x 1 1/4" BORE	91.00

ADJUSTABLE DOUBLE EASING SHAPER

Adjustable Double Easing set includes:
2 cutters, 2 spacers, and a shim set.

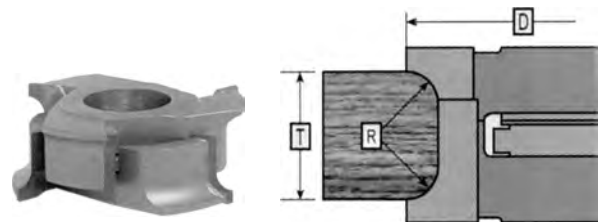

3 WING - CARBIDE TIPPED

Order No.	Radius	T Material Thickness	Outside Diameters		Price
			3/4" Arbor	1" & 1 1/4" Arbor	
K-1498	1/8	11/16 to 1-1/2	2-3/4	3-1/4	\$508.00
K-1499	1/4	11/16 to 1-1/2	3	3-1/2	58.00

**Custom Cutters
Made To Order**

**CALL TOLL FREE 1-800-443-0992 • FAX TOLL FREE 1-888-728-8665
or visit our web site at www.ridgecarbide.com**



STRAIGHT AND BEVEL ANGLE CUTTERS



STRAIGHT EDGE SHAPER

AVAILABLE BEARINGS			
C-885	2 1/4" x 3/4" BORE	\$77.00	
C-887	2 3/4" x 1" BORE	82.00	
C-891	2 3/4" x 1 1/4" BORE	91.00	

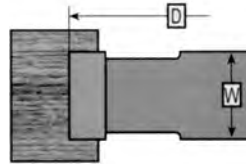

Custom Cutters
Made To Order



3 WING - CARBIDE TIPPED				
Order No.	W Width	Outside Diameters		Price
		3/4" Arbor	1" & 1 1/4" Arbor	
K-1440	1/4	3-1/8	3-5/8	\$101.00
K-1441	3/8	3-1/5	3-5/8	106.00
K-1442	1/2	3-1/8	3-5/8	116.00
K-1443	5/8	3-1/8	3-5/8	126.00
K-1444	3/4	3-1/8	3-5/8	138.00
K-1445	7/8	3-1/8	3-5/8	142.00
K-1446	1	3-1/8	3-5/8	148.00
K-1447	1-1/4	3-1/8	3-5/8	166.00
K-1448	1-1/2	3-1/8	3-5/8	184.00
K-1449	1-3/4	3-1/8	3-5/8	198.00
K-1450	2	3-1/8	3-5/8	209.00
K-1451	3-1/4	3-1/8	3-5/8	225.00
K-1452	2-1/2	3-1/8	3-5/8	250.00
K-1453	3	3-1/8	3-5/8	276.00
K1454	3-1/2	3-1/8	3-5/8	345.00

ANGLE BEVEL SHAPER



Stock cutters are 1" wide, but other widths are available as Non-Stock items.

3 WING - CARBIDE TIPPED					
Order No.	Angle	Max. Material Thickness	Outside Diameters		Price
			3/4" Arbor	1" & 1 1/4" Arbor	
K-1165	45°	15/16	4-1/8	4-5/8	\$240.00
K-1165-FU	45°	15/16	4-1/8	4-5/8	240.00
K-1166	30°	15/16	3-7/16	3-15/16	201.00
K-1166-FU	30°	15/16	3-7/16	3-15/16	201.00
K-1166-22.5	22.5°	15/16	3-1/16	3-9/16	225.00

AVAILABLE BEARINGS			
C-885	2 1/4" x 3/4" BORE	\$77.00	
C-887	2 3/4" x 1" BORE	82.00	
C-891	2 3/4" x 1 1/4" BORE	91.00	

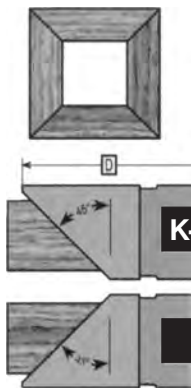

K-1165-FU

K-1165

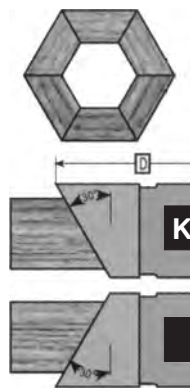

K-1166-FU

K-1166

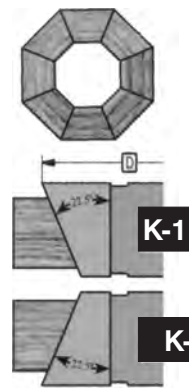

K-1166-22.5-FU

K-1166-22.5

CALL TOLL FREE 1-800-443-0992 • FAX TOLL FREE 1-888-728-8665
or visit our web site at www.ridgecarbide.com



T&G, FLOORING, V-PANEL and WEDGE CUTTERS



NOT TO SCALE

T&G FOR FLOORING FOR 3/4" MATERIAL



FLOORING

K-725

\$626.00

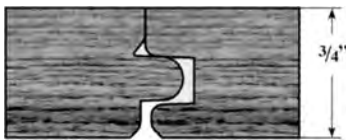

T&G FOR SHAKER DOORS FOR 1-1/8" MATERIAL

PR-T&G

\$466.00

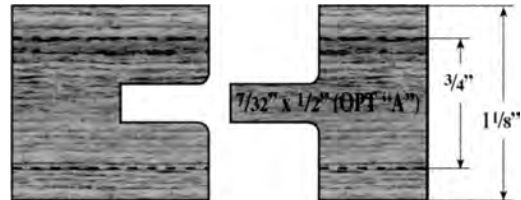

• A spacer is placed between cutters for a cope cut.

STRAIGHT T&G FOR 1-1/4" MATERIAL

SET "A"

K-736

\$300.00

SET "B"

K-736

\$407.00

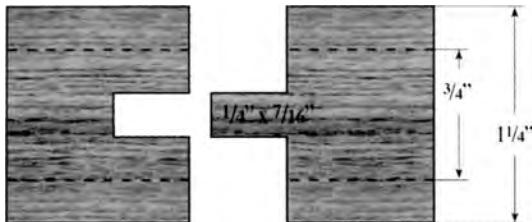

SET "A" STYLE

3 CUTTERS
1 SHIM SET

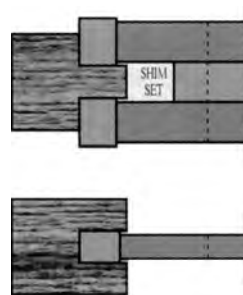

SET "B" STYLE

6 CUTTERS

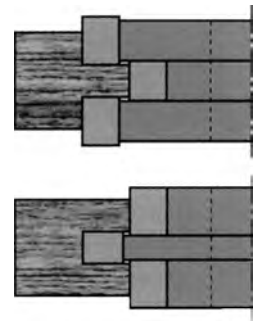

3 WING - CARBIDE TIPPED

Order No.	Outside Diameters	
	3/4" Arbor	1" & 1 1/4" Arbor
K-725	3-1/16	3-9/16
K-729	3-5/8	4-1/8
K-730	3-5/8	4-1/8
K-736 Set A	3-1/8	3-5/8
K-736 Set B	3-1/8	3-5/8
PR-T&G	3-1/4	3-3/4

"V" PANEL T&G SHAPERS & WEDGE T&G SHAPERS

FOR 1" MATERIAL



K-729 (FU or FD)

\$478.00

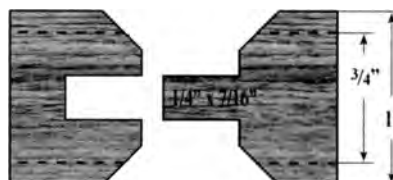

K-730

\$527.00



CALL TOLL FREE 1-800-443-0992 • FAX TOLL FREE 1-888-728-8665
or visit our web site at www.ridgecarbide.com



CABINET & GLASS DOOR CUTTERS



NOT TO SCALE

“COMPONENT” COPE & STICK SETS

ADVANTAGE

- 1) Sets are available face-up or face-down.
- 2) All are available with Opt. "A" Eased Edge. Opt. "A" Set will only produce a cabinet door cut.
- 3) Available with 5.5mm or 1/4" by 7/16" deep tongue.
- 4) Constant minor diameter and tool width requires no fence or height adjustment when changing heads.
- 5) Sets will produce cabinet door, glass door, and shaker door styles.
- 6) All bores are honed for accuracy.
- 7) All tools are balanced for vibration-free smooth cuts.

3 WING - CARBIDE TIPPED

Order No.	Price
All Sets with 5.5 Tongue	\$439.00
*Same Set Tipped in Tangtung	605.00



PR-48-FU \$521.00
PR-48-FD \$521.00

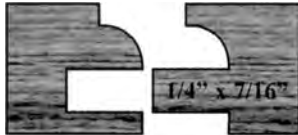

SET WITH OPT. A \$624.00

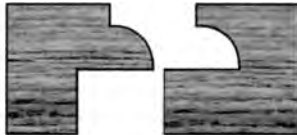

***KT-48-FD (H-ALLOY) \$650.00**

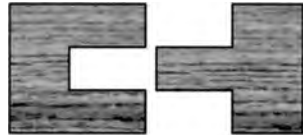

PR-49-FU \$521.00
PR-49-FD \$521.00

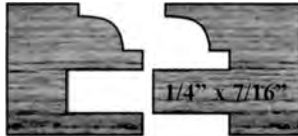

SET WITH OPT. A \$624.00

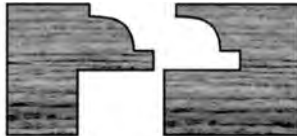

***KT-49-FD (H-ALLOY) \$650.00**

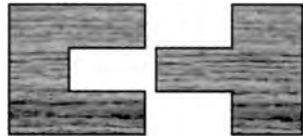

PR-50-FU \$521.00
PR-50-FD \$521.00

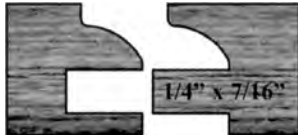

SET WITH OPT. A \$624.00

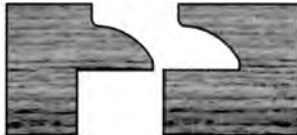

***KT-50-FD (H-ALLOY) \$650.00**

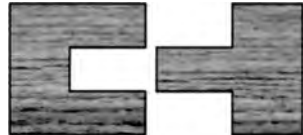

PR-750-FU \$521.00
PR-750-FD \$521.00



SET WITH OPT. A \$624.00

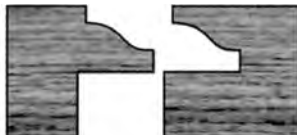

***KT-750-FD (H-ALLOY) \$650.00**

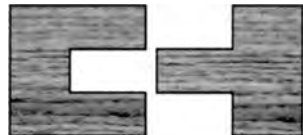

CALL TOLL FREE 1-800-443-0992 • FAX TOLL FREE 1-888-728-8665
or visit our web site at www.ridgecarbide.com



CABINET & GLASS DOOR CUTTERS



NOT TO SCALE

“COMPONENT” COPE & STICK SETS

Sets are for 3/4" to 1-1/8" material, and wood samples are shown face up. The Outside Diameters for 1" and 1-1/4" bores are 3-5/8", and 3/4" bores are 3-1/8".



PR-752P-FU \$521.00
PR-752P-FD \$521.00

**SET WITH
 OPT. A \$624.00**

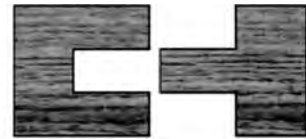
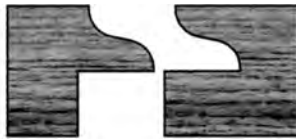
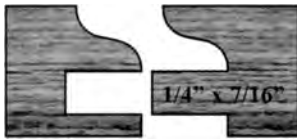

PR-54-FU \$521.00
PR-54-FD \$521.00

**SET WITH
 OPT. A \$624.00**

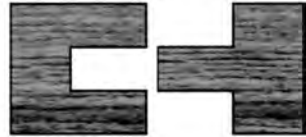
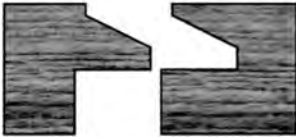
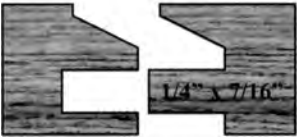

PR-56P-FU \$521.00
PR-56P-FD \$521.00

**SET WITH
 OPT. A \$624.00**

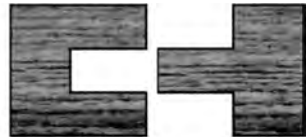
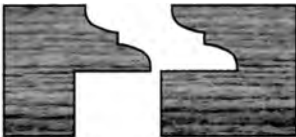

PR-25P-FU \$521.00
PR-25P-FD \$521.00

**SET WITH
 OPT. A \$624.00**

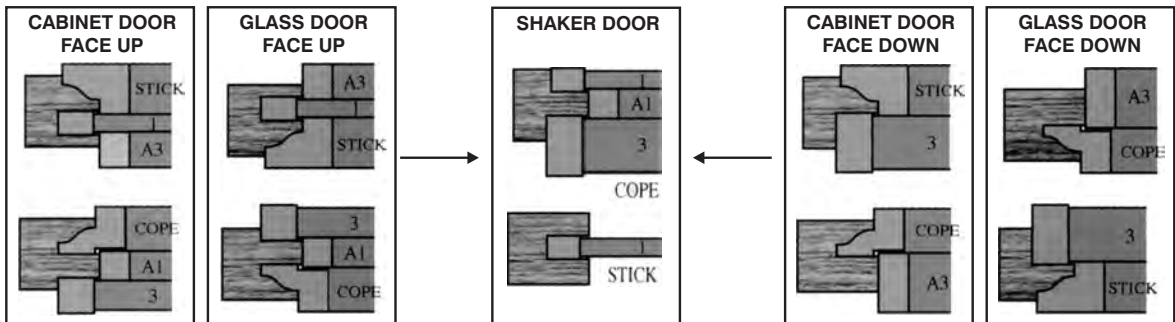
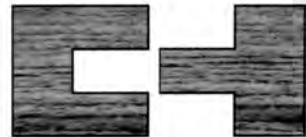
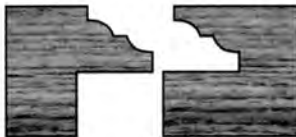
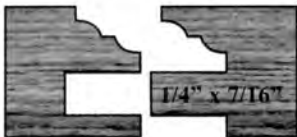

CALL TOLL FREE 1-800-443-0992 • FAX TOLL FREE 1-888-728-8665
 or visit our web site at www.ridgecarbide.com



CABINET DOOR & INTERIOR DOOR CUTTERS



NOT TO SCALE

3 WING - CARBIDE TIPPED

**DOUBLE DETAIL SETS
FOR 3/4" TO 7/8" MATERIAL**

Your Choice
\$549.00

K-751

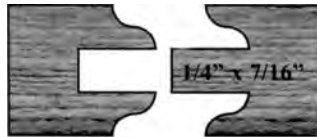

K-753



AVAILABLE BEARINGS

C-885	2 1/4" x 3/4" BORE	\$77.00
C-887	2 3/4" x 1" BORE	82.00
C-891	2 3/4" x 1 1/4" BORE	91.00

• The outside diameters for 1" and 1-1/4" bores are 3-5/8", and 3/4" bores are 3-1/8".

Your Choice
\$589.00

3 WING - CARBIDE TIPPED

**DOUBLE DETAIL SETS
FOR 1" TO 1-1/8" MATERIAL**

• The outside diameters for 1" and 1-1/4" bores are 3-5/8", and 3/4" bores are 3-1/8".



AVAILABLE BEARINGS

C-885	2 1/4" x 3/4" BORE	\$77.00
C-887	2 3/4" x 1" BORE	82.00
C-891	2 3/4" x 1 1/4" BORE	91.00



K-760

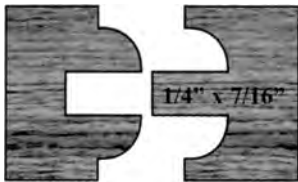

K-761



K-762

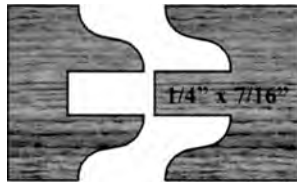

K-763



K-764



K-766P4



K-767P



K-768P

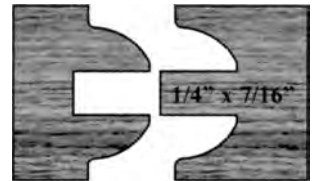

**CALL TOLL FREE 1-800-443-0992 • FAX TOLL FREE 1-888-728-8665
or visit our web site at www.ridgecarbide.com**



INTERIOR DOOR CUTTERS



DOUBLE DETAIL SETS
FOR 1-3/8" MATERIAL (1/4" WIDE T&G)

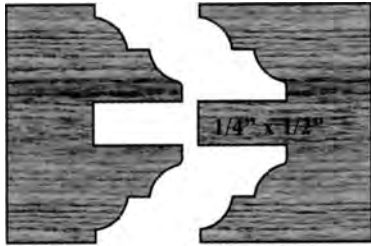

K-770P
\$823.00

K-771
\$788.00

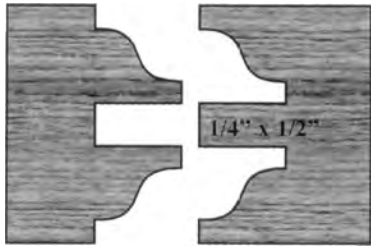

K-772
\$788.00



K-773P
\$788.00



NOT TO SCALE

EXTERIOR DOOR CUTTERS

2" MATERIAL (1/2" WIDE T&G)

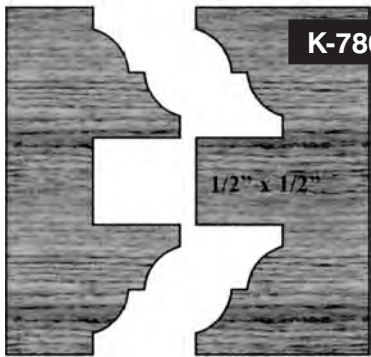

K-780P-12

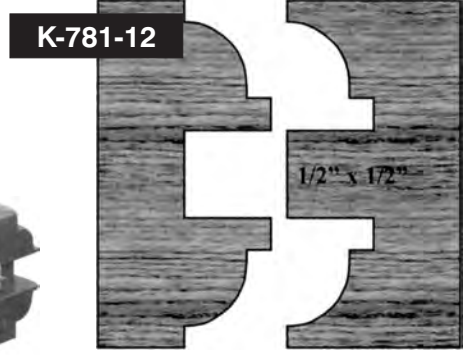

K-781-12

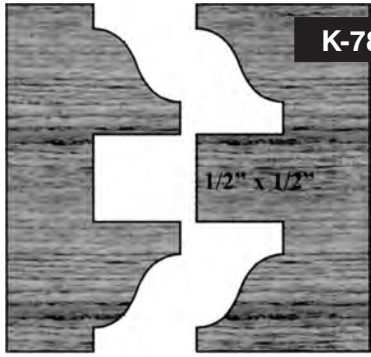

K-782-12

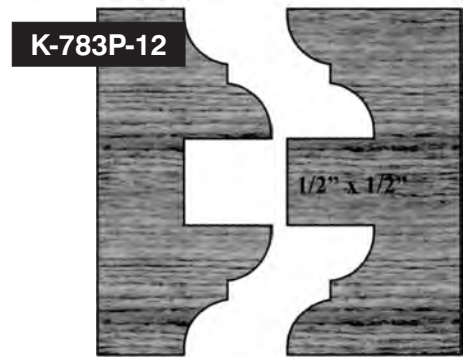

K-783P-12

NOT TO SCALE

3 WING - CARBIDE TIPPED

• The outside diameters for 1" and 1-1/4" bores are 3-3/4", and 3/4" bores are 3-1/4".

AVAILABLE BEARINGS		
C-885	2 1/4" x 3/4" BORE	\$77.00
C-887	2 3/4" x 1" BORE	82.00
C-891	2 3/4" x 1 1/4" BORE	91.00

CALL TOLL FREE 1-800-443-0992 • FAX TOLL FREE 1-888-728-8665
or visit our web site at www.ridgecarbide.com



EXTERIOR DOOR CUTTERS



1-3/4" MATERIAL (1/4" WIDE T&G)

3 WING - CARBIDE TIPPED

• The outside diameters for 1" and 1-1/4" bores are 3-3/4", and 3/4" bores are 3-1/4".

AVAILABLE BEARINGS

C-885	2 1/4" x 3/4" BORE	\$77.00
C-887	2 3/4" x 1" BORE	82.00
C-891	2 3/4" x 1 1/4" BORE	91.00

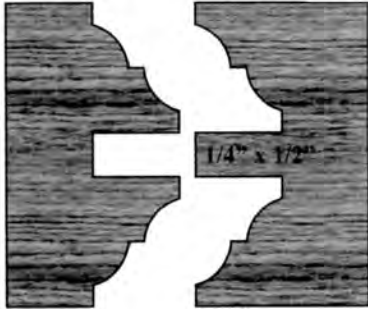

K-780P
\$989.00

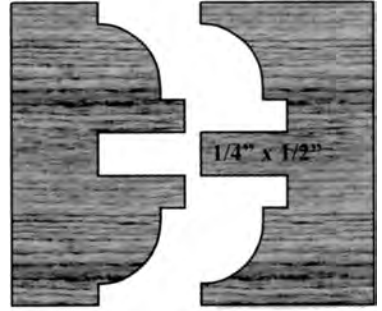

K-781
\$945.00

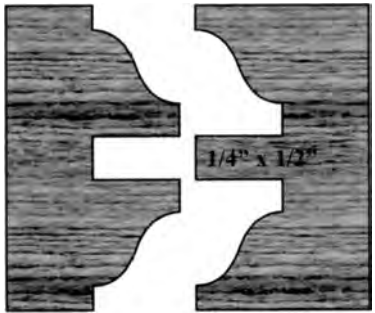

K-782
\$945.00



K-783P
\$989.00



NOT TO SCALE

1-3/4" MATERIAL (1/2" WIDE T&G)

3 WING - CARBIDE TIPPED

• The outside diameters for 1" and 1-1/4" bores are 3-3/4", and 3/4" bores are 3-1/4".

AVAILABLE BEARINGS

C-885	2 1/4" x 3/4" BORE	\$77.00
C-887	2 3/4" x 1" BORE	82.00
C-891	2 3/4" x 1 1/4" BORE	91.00

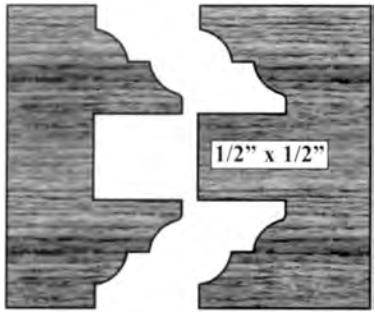

K-770P-12
\$872.00



K-771-12
\$872.00

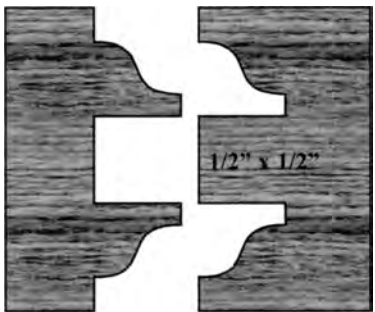

K-772-12
\$872.00



K-773P-12
\$872.00



NOT TO SCALE

CALL TOLL FREE 1-800-443-0992 • FAX TOLL FREE 1-888-728-8665
or visit our web site at www.ridgecarbide.com



RAISED PANEL CUTTERS



K-1085-SA
\$270.00



SINGLE RAISED PANELS FOR 1/2" MATERIAL

AVAILABLE BEARINGS

C-884	1 5/8" x 3/4" BORE	\$69.00
C-886	2" x 1" BORE	69.00
C-890	2 1/4" x 1 1/4" BORE	79.00

K-1086-SA
\$273.00



**NOT TO SCALE
ALL 1-1/2" REVEAL**

3 WING - CARBIDE TIPPED

Order No.	Availability	Profile Depth	Outside Diameters		
			3/4" Arbor	1" Arbor	1 1/4" Arbor
K-1085-SA	In Stock	1-5/8	4-7/8	5-1/4	5-1/2
K-1086-SA	In Stock	1-5/8	4-7/8	5-1/4	5-1/2

**Custom Raised
Panel Cutters
Made To Order**

K-1022P
\$256.00

SINGLE RAISED PANELS FOR 5/8" MATERIAL 3/8" FLAT ON ALL TOOLS

K-1023
\$256.00

K-1041
\$261.00

K-1045
\$296.00

K-1025
\$264.00

K-1040
\$261.00

K-1049
\$270.00

K-1036-FD*
K-1036
\$261.00

AVAILABLE BEARINGS

C-884	1 1/2" x 3/4" BORE	\$69.00
C-886	2" x 1" BORE	69.00
C-890	2 1/4" x 1 1/4" BORE	79.00

K-1070-FD*
K-1070
\$261.00

K-1038
\$270.00



3 WING - CARBIDE TIPPED

Order No.	Availability	Profile Depth	Outside Diameters		
			3/4" Arbor	1" Arbor	1 1/4" Arbor
K-1022P	In Stock	1-1/2	4-5/8	5	5-1/4
K-1023	In Stock	1-3/8	4-3/8	4-3/4	5
K-1025	In Stock	1-1/2	4-5/8	5	5-1/4
K-1036 or FD	In Stock	1-5/8	4-7/8	5-1/4	5-1/2
K-1038	In Stock	1-5/8	4-7/8	5-1/4	5-1/2
K-1040	In Stock	1-5/8	4-7/8	5-1/4	5-1/2
K-1041	In Stock	1-5/8	4-7/8	5-1/4	5-1/2
K-1045	In Stock	1-5/8	4-7/8	5-1/4	5-1/2
K-1049	In Stock	1-5/8	4-7/8	5-1/4	5-1/2
K-1070 or FD	In Stock	1-3/8	4-3/8	4-3/4	5

*FD=Face Down. Profiles shown are for CCW rotation face up design. For cutters CCW rotation face down except K-1070-FD add 20% to above price.

**CALL TOLL FREE 1-800-443-0992 • FAX TOLL FREE 1-888-728-8665
or visit our web site at www.ridgecarbide.com**



RAISED PANEL CUTTERS



NOT TO SCALE - ALL 1-1/2" REVEAL

SINGLE RAISED PANELS FOR 3/4" MATERIAL

K-1042-FD*
K-1042
\$270.00

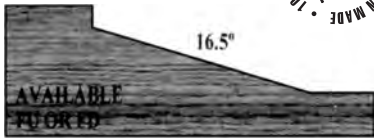

AVAILABLE BEARINGS
C-884 1 7/8" x 3/4" BORE \$69.00
C-886 2" x 1" BORE 69.00
C-890 2 1/4" x 1 1/4" BORE 79.00

K-1043
\$271.00

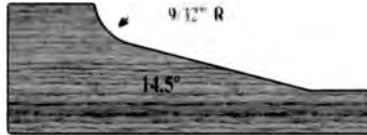

K-1070-FD*
K-1070
\$261.00

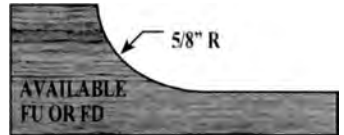

K-1037
\$273.00

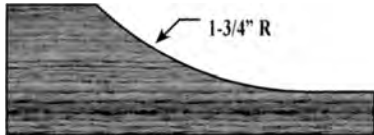

K-1051
\$310.00

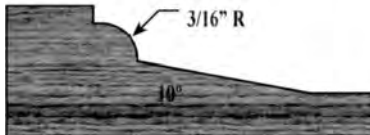

K-1044
\$283.00

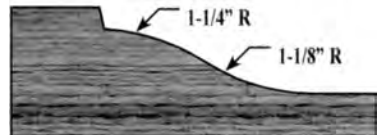

K-1039
\$283.00

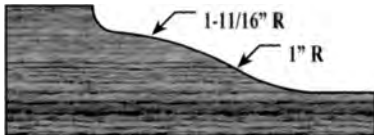

K-1064
\$265.00

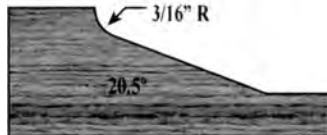

K-1066
\$267.00

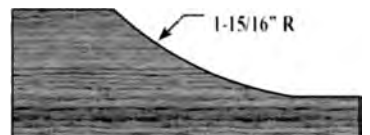

*FD=Face Down. Profiles shown are for CCW rotation face up design. For cutters CCW rotation face down except K-1042-FD & K-1070-FD add 20% to above price.

3 WING - CARBIDE TIPPED

Order No.	Availability	Profile Depth	Outside Diameters		
			3/4" Arbor	1" Arbor	1 1/4" Arbor
K-1037	In Stock	1-5/8	4-7/8	5-1/4	5-1/2
K-1039	In Stock	1-5/8	4-7/8	5-1/4	5-1/2
K-1042	In Stock	1-5/8	4-7/8	5-1/4	5-1/2
K-1043	In Stock	1-5/8	4-7/8	5-1/4	5-1/2
K-1044	In Stock	1-5/8	4-7/8	5-1/4	5-1/2
K-1051	In Stock	1-5/8	4-7/8	5-1/4	5-1/2
K-1064	In Stock	1-1/8	4-3/8	4-3/4	5
K-1066	In Stock	1-1/4	4-5/8	5	5-1/4
K-1070	In Stock	1-3/8	4-3/8	4-3/4	5

CALL TOLL FREE 1-800-443-0992 • FAX TOLL FREE 1-888-728-8665
or visit our web site at www.ridgecarbide.com



RAISED PANEL CUTTERS



DOUBLE RAISED PANELS FOR 1-3/4" TO 1-1/2" MATERIAL

1-3/8" SHOWN WITH 3/8" FLATS

- NOTES FOR IN STOCK ITEMS:**
- Set includes 2 cutters and a spacer.
 - Bearing option is available upon request.

3 WING - CARBIDE TIPPED

Order No.	Availability	Profile Depth	Outside Diameters		
			3/4" Arbor	1" Arbor	1 1/4" Arbor
K-1036-SB	In Stock	1-5/8	4-7/8	5-1/4	5-1/2
K-1070-SB	In Stock	1-3/8	4-3/8	4-3/4	5
K-1042-SB	In Stock	1-5/8	4-7/8	5-1/4	5-1/2

**NOT TO SCALE
ALL 1-1/2" REVEAL**

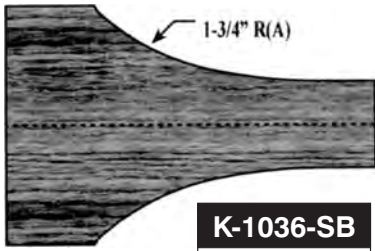

K-1036-SB
\$555.00

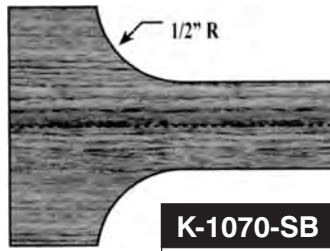

K-1070-SB
\$554.00

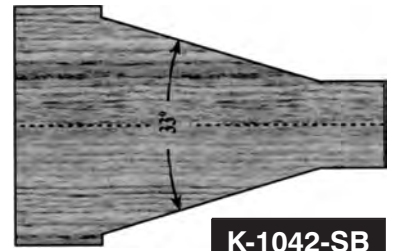

K-1042-SB
\$573.00

PARTIAL DOUBLE RAISED PANELS



K-1090-A
\$221.00

• K-1090A Set includes a spacer.

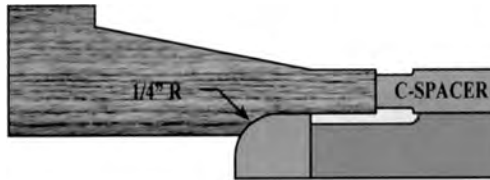

K-1090-B
\$218.00

• K-1090B Set includes a spacer.

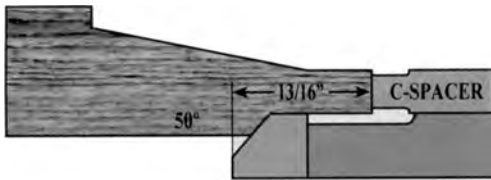

K-1090-A-BB
\$316.00

K-1090-B-BB
\$315.00

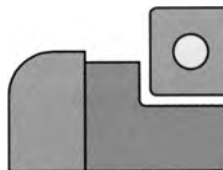

• K-1090-BB Set include a cutter, a bearing, and one shim for adjustability.

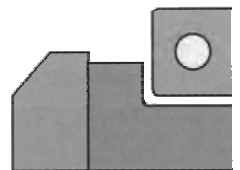

C-Cutter
\$101.00

• A C-Cutter is available for replacing a spacer when shaping material.



3 WING - CARBIDE TIPPED

Order No.	Availability	Outside Diameters		
		3/4" Arbor	1" Arbor	1 1/4" Arbor
K-1090A	In Stock	3-1/4	3-5/8	3-7/8
K-1090B	In Stock	3-1/4	3-5/8	3-7/8
K-1090A-BB	In Stock	3-1/4	3-5/8	3-7/8
K-1090B-BB	In Stock	3-1/4	3-5/8	3-7/8
C-Cutter	In Stock	1-5/8	2	2-1/4

**CALL TOLL FREE 1-800-443-0992 • FAX TOLL FREE 1-888-728-8665
or visit our web site at www.ridgecarbide.com**



EDGE DETAIL CUTTERS



“COMPONENT” TOP DETAIL DOOR LIP CUTTERS FOR 3/4” TO 1-1/8” MATERIAL

- All Top and Bottom Detail Door Lip Cutters are compatible with each other.
- Refer to this page for examples of how to set up “Component” Door Lip Cutters.

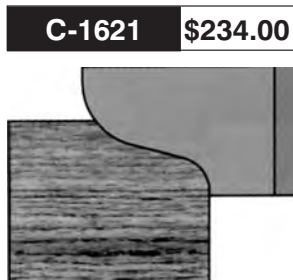
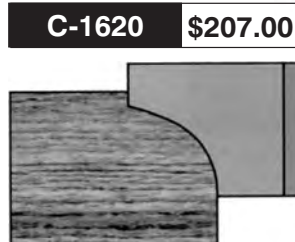
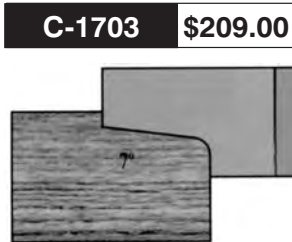
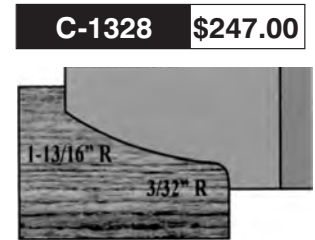
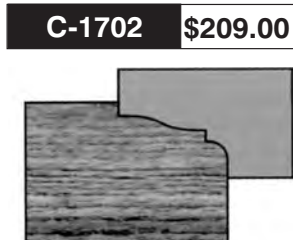
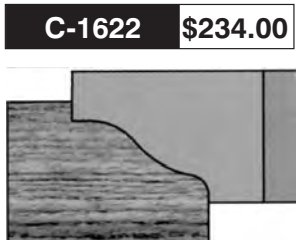
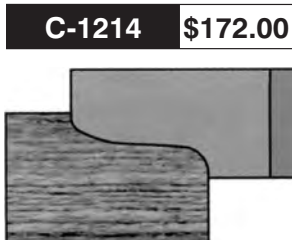
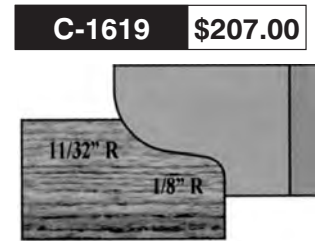
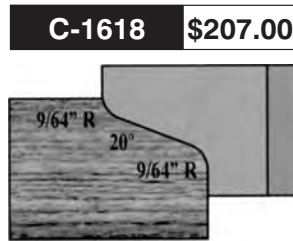
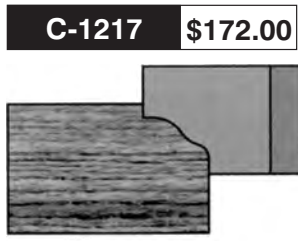
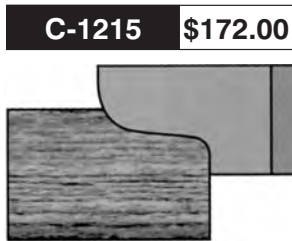
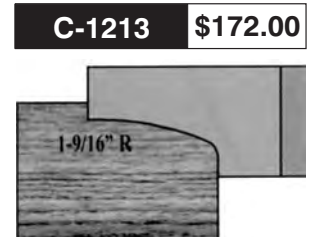
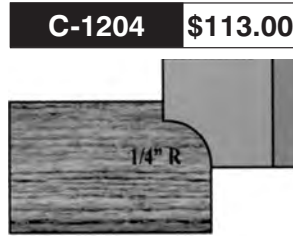
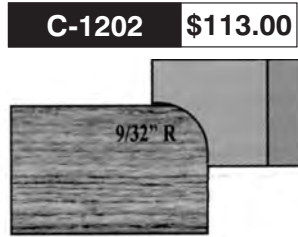
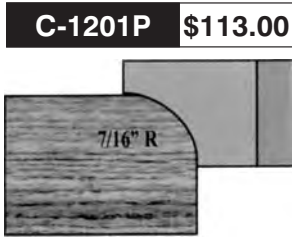

NOT TO SCALE

3 WING - CARBIDE TIPPED

Order No.	Availability	Outside Diameters	
		3/4" Arbor	1 & 1/4" Arbor
C-1201P	In Stock	2-13/16	3-25/32
C-1202	In Stock	2-19/32	3-9/16
C-1204	In Stock	2-1/2	3-7/16
C-1213	In Stock	3-27/32	4-7/8
C-1214	In Stock	3-1/2	4-15/32
C-1215	In Stock	3-7/32	4-3/16
C-1217	In Stock	2-11/16	3-21/32
C-1328	In Stock	3-29/32	4-7/8
C-1618	In Stock	3-5/32	4-1/8
C-1619	In Stock	3-3/16	4-5/32
C-1620	In Stock	2-15/16	3-29/32
C-1621	In Stock	3-13/32	4-3/8
C-1622	In Stock	3-1/2	4-15/32
C-1702	In Stock	3-3/16	4-5/32
C-1703	In Stock	3-3/16	4-5/32

**CALL TOLL FREE 1-800-443-0992 • FAX TOLL FREE 1-888-728-8665
or visit our web site at www.ridgecarbide.com**



EDGE DETAIL CUTTERS



DETAIL SHAPER CUTTERS

FOR 3/4" TO 7/8" MATERIAL

3/4" MATERIAL SHOWN

NOT TO SCALE

K-1104
\$257.00

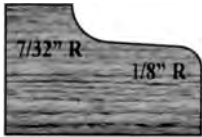

K-1196
\$251.00



K-2012
\$286.00



K-2013
\$265.00

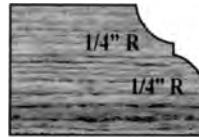

K-1120
\$246.00

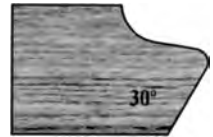

K-1154
\$251.00



K-1152P
\$230.00

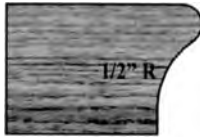

K-2011
\$281.00



K-1168
\$230.00

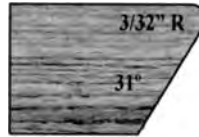

K-1157
\$221.00



K-1199
\$257.00



K-1133
\$248.00



K-144
\$297.00



K-182
\$304.00



K-178
\$278.00



K-183
\$300.00



K-1460
\$252.00

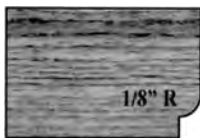

K-1462
\$252.00

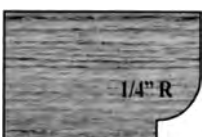

**Custom
Profile Cutters
Made To Order
Fax Drawing
For Quote**

3 WING - CARBIDE TIPPED

Order No.	Availability	Outside Diameters	
		3/4" Arbor	1 & 1/4" Arbor
K-1104	In Stock	3-3/4	4-1/4
K-1120	In Stock	3-1/4	3-3/4
K-1133	In Stock	3-7/8	4-3/8
K-1152P	In Stock	3-1/16	3-9/16
K-1154	In Stock	3-1/2	4
K-1157	In Stock	3	3-1/2
K-1168	In Stock	3-1/4	3-3/4
K-1196	In Stock	3-3/4	4-1/4
K-1199	In Stock	3-9/16	4-1/16
K-144	In Stock	3-1/4	3-3/4
K-1460	In Stock	2-1/2	3
K-1462	In Stock	2-3/4	3-1/4
K-178	In Stock	3	3-1/2
K-182	In Stock	3-1/2	4
K-183	In Stock	3-1/4	3-3/4
K-2011	In Stock	3	3-1/2
K-2012	In Stock	3-3/8	3-7/8
K-2013	In Stock	3-1/16	3-9/16

**CALL TOLL FREE 1-800-443-0992 • FAX TOLL FREE 1-888-728-8665
or visit our web site at www.ridgecarbide.com**



EDGE DETAIL CUTTERS



NOT TO SCALE

How To Set Up "Component" Door Lip Cutters

Shims are placed between the top and bottom cutters to acquire desired cut for various material sizes.

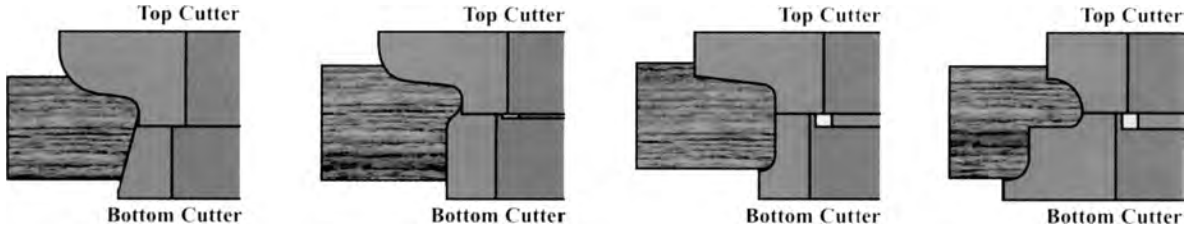

"COMPONENT" BOTTOM DOOR LIP CUTTERS



C-1-CP
\$156.00

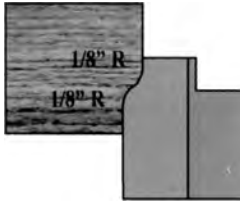

C-3-S
\$128.00

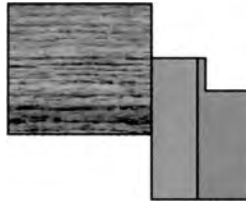

C-3-SEP
\$140.00

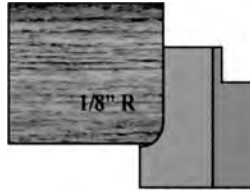

C-4
\$135.00

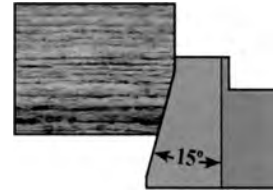

C-1-CEP
\$170.00

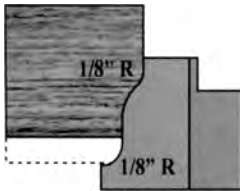

C-1
\$112.00

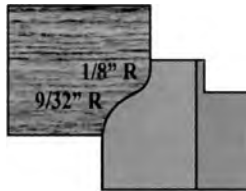

- Each bottom cutter includes a few shims for adjustability.
- All Bottom Door Lip cutters will match with "Component" Top Door Lip cutters in the previous section.

C-3P
\$112.00

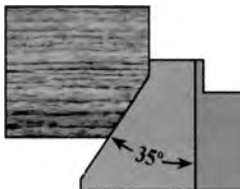

C-2
\$128.00

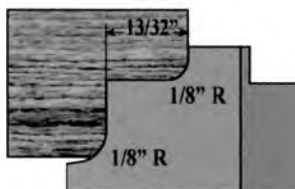

3 WING - CARBIDE TIPPED

Order No.	Availability	Outside Diameters	
		3/8" Arbor	1 & 1/4" Arbor
C-1-CP	In Stock	2-17/64	3-1/8
C-3-S	In Stock	1-15/16	2-29/32
C-3-SEP	In Stock	2-3/16	3-5/32
C-4	In Stock	2-1/4	3-7/32
C-1-CEP	In Stock	2-7/16	3-13/32
C-1	In Stock	2-1/2	3-15/32
C-3P	In Stock	2-23/32	3-11/16
C-2	In Stock	3-3/16	4-1/8

CALL TOLL FREE 1-800-443-0992 • FAX TOLL FREE 1-888-728-8665
or visit our web site at www.ridgecarbide.com



GLUE JOINT CUTTER LOCK-MITER JOINTS



GLUE JOINT CUTTERS

NOT TO SCALE

Order No.	Availability	Outside Diameters	
		3/4" Arbor	1 & 1/4" Arbor
K-717P	In Stock	2-19/32	3-3/32
K-718P	In Stock	2-19/32	3-3/32

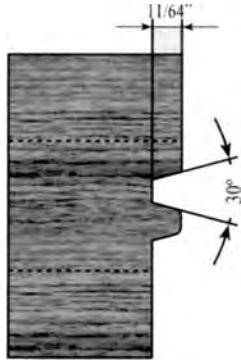

K-717P
\$315.00

3/4" to 1 1/4" Material

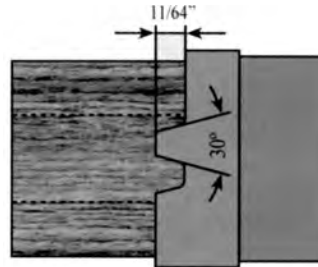

K-718P
\$261.00

1/2" to 1 1/8" Material

LOCK-MITER SETS

Advantage:

Our Multi-Piece Lock-Miter sets are designed with a shim for adjustability. The benefit allows the cutter to maintain a good joint throughout the life of the tool.

K-757
\$359.00

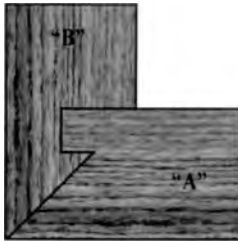

K-747
\$386.00

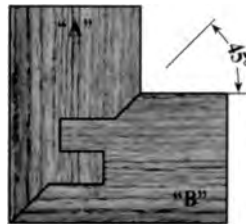

Both "A" and "B" are run flat on the shaper table. Part "B" is run again on a table saw to cut the groove.

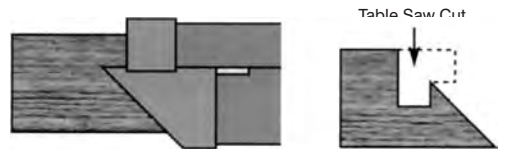

K-748
\$348.00

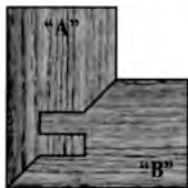

K-749
\$353.00

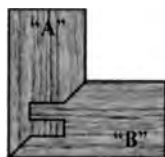

Order No.	Availability	Outside Diameters	
		3/4" Arbor	1 & 1/4" Arbor
K-747	In Stock	4-11/16	5-3/16
K-748	In Stock	3-5/8	4-1/8
K-757	In Stock	3-1/2	4
K-749	Non-Stock	3-7/16	4/3/16

When properly positioned this cutter set will cut "A" and "B" matching joints without changing the vertical adjustment of the cutter on the shaper.

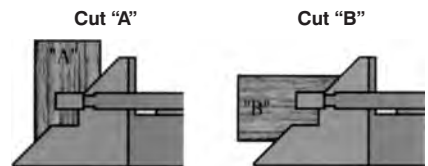



REVERSIBLES ARCHITECTURAL CUTTERS



MATCHED REVERSIBLE DETAIL CUTTERS

K-144
\$297.00



K-178
\$278.00

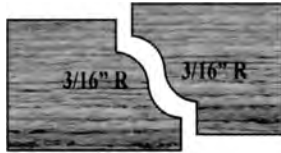

K-182
\$304.00

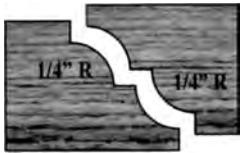

K-183
\$300.00

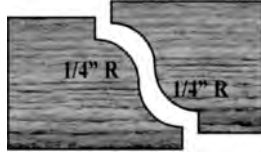

3 WING - CARBIDE TIPPED

Order No.	Availability	Outside Diameters	
		3/4" Arbor	1 & 1/4" Arbor
K-144	In Stock	3-1/4	3-3/4
K-178	In Stock	3	3-1/2
K-182	In Stock	3-1/2	4
K-183	In Stock	3-1/4	3-3/4

* Each pattern is made with one reversible cutter. All of the material is passed through the same way. Turn over one piece and it becomes a perfect fitting joint.



NOT TO SCALE

HAND RAIL CUTTERS

6010 HAND RAIL

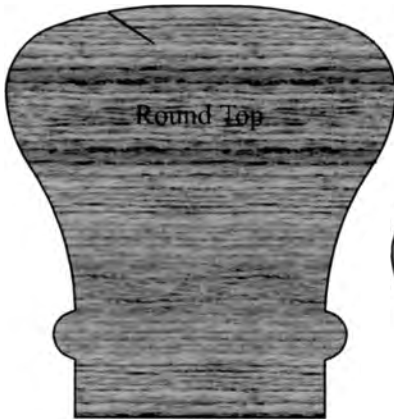

K-1880
\$691.00



K-1885
\$706.00

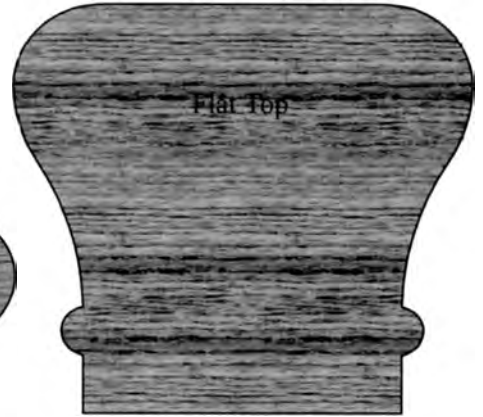

K-1884
\$621.00

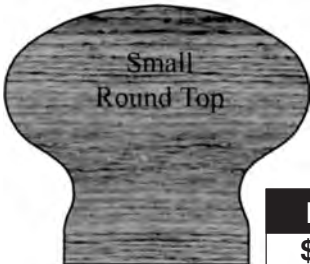

K-1882
\$499.00

3 WING - CARBIDE TIPPED

Order No.	Availability	Outside Diameters	
		3/4" Arbor	1 & 1/4" Arbor
K-1880	Non-Stock	4-13/16	5-5/16
K-1882	Non-Stock	4-1/4	4-3/4
K-1884	Non-Stock	3-1/2	4
K-1885	Non-Stock	5	5-1/2

CALL TOLL FREE 1-800-443-0992 • FAX TOLL FREE 1-888-728-8665
or visit our web site at www.ridgecarbide.com



MAGIC MOLDER

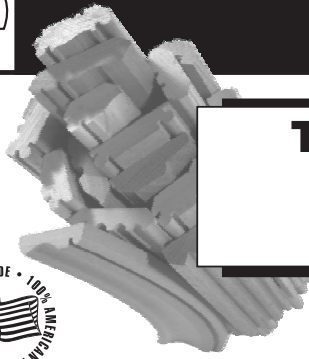

TURN YOUR TABLE SAW INTO A MOLDER WITH MAGIC MOLDER



The unique design of the Magic Molder allows the universal head to be anti-kickback with any profile. The chip limiting design produces smooth, vibration-free cuts. It is a 7" diameter and is available with 5/8", 3/4", or a 1" bore. Other bore sizes are available for service charge of \$30.00

For Your Table Saw MAGIC MOLDER HEAD INTRODUCTORY OFFER

Choose One of 72 Different Profiles!

\$206.00

Set Includes: One Magic Molder Head and any One Detail Set of seventy-two available profile plugs.

#PR-MM-2

To order the Magic Molder use stock number *PR-MM* and list the chosen detail. Example: *PR-MM with P-20*.



#MM-STARTER SET INCLUDES ONE HEAD AND 2 PR. PLUGS



\$295.00

FOR YOUR SHAPER MACHINE UNIVERSAL "MAGIC SHAPER HEAD"

Anti-kickback Chip Limiting Stackable



Plugs for the Magic Molder and Magic Shaper are interchangeable. Custom plugs are also available.

Available In 3/4" and 1 1/4" Bores

Order No.	Tip Diameters	Price
MS-1-1/4	5-5/8	\$209.00
MS-3/4	4-7/8	209.00

Plug Profiles Additional

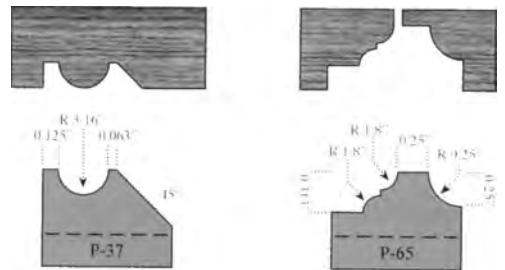

DRAWINGS NOT TO SCALE

#MM-ADVANCED STARTER SET INCLUDES ONE HEAD AND 4 PR. PLUGS

\$469.00



DRAWINGS NOT TO SCALE

**CALL TOLL FREE 1-800-443-0992 • FAX TOLL FREE 1-888-728-8665
or visit our web site at www.ridgecarbide.com**



Your Choice
\$99.00
 per pair

MAGIC MOLDER PLUGS

CARBIDE TIPPED - NOT TO SCALE

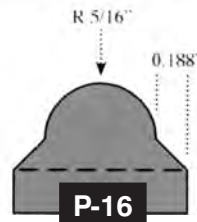
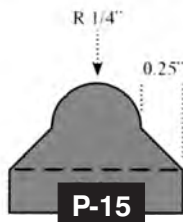
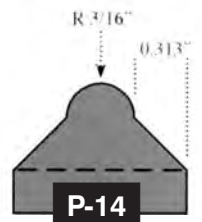
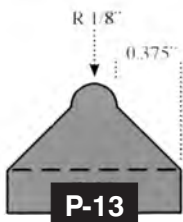
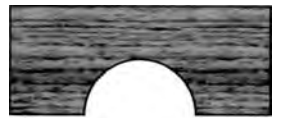
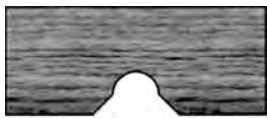
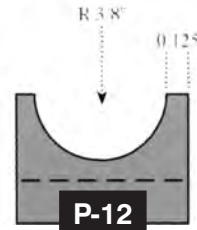
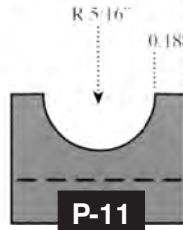
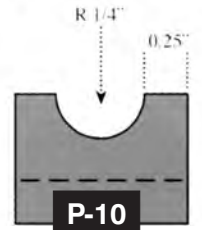
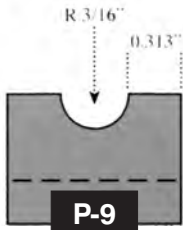
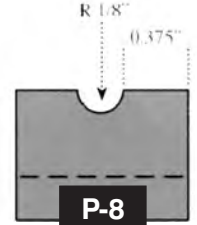
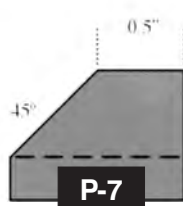
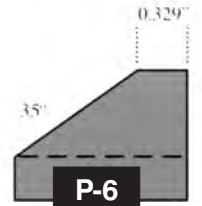
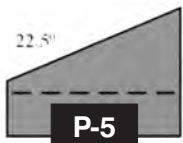
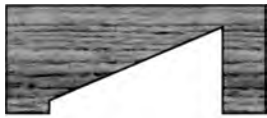
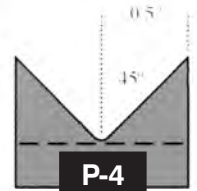
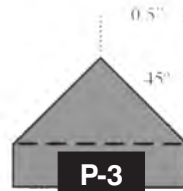
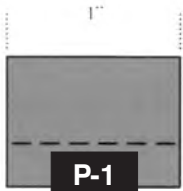
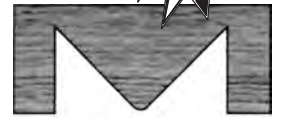

CALL TOLL FREE 1-800-443-0992 • FAX TOLL FREE 1-888-728-8665
 or visit our web site at www.ridgecarbide.com



Your Choice
\$99.00
 per pair

MAGIC MOLDER PLUGS

CARBIDE TIPPED - NOT TO SCALE

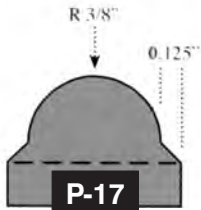
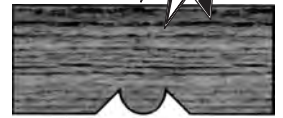

P-17

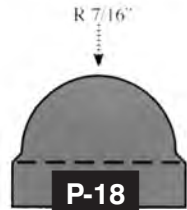

P-18

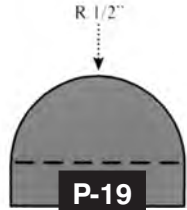

P-19

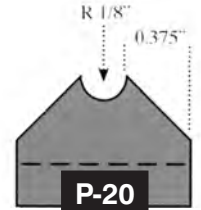

P-20

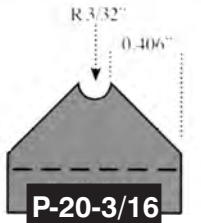
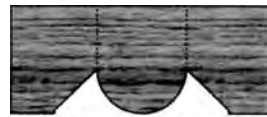

P-20-3/16

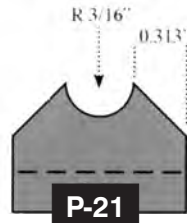

P-21

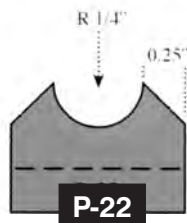

P-22

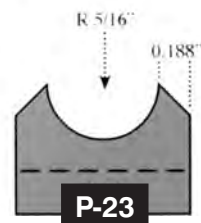

P-23

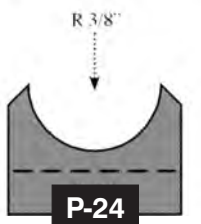
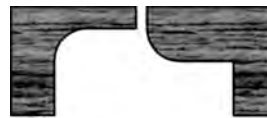

P-24

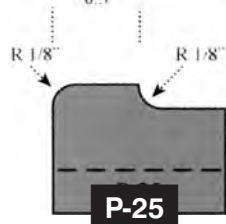

P-25

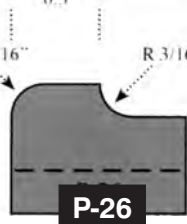

P-26

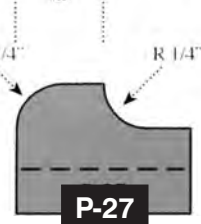

P-27

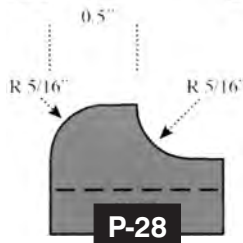
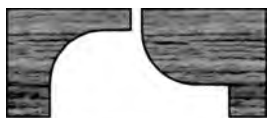

P-28

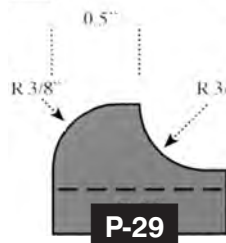

P-29

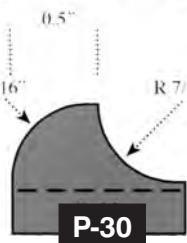

P-30

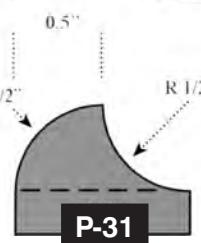

P-31



CALL TOLL FREE 1-800-443-0992 • FAX TOLL FREE 1-888-728-8665
 or visit our web site at www.ridgecarbide.com



Your Choice
\$99.00
 per pair

MAGIC MOLDER PLUGS

CARBIDE TIPPED - NOT TO SCALE



0.658"
 R 5/32" R 5/32" R 5/32"

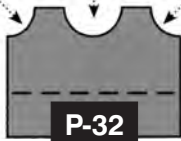

P-32



0.171"
 R 5/32"

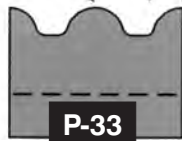

P-33



0.843"
 R 9/64" 0.281" 0.094"



P-34



0.312" R 5/32"
 0.125" 0.125"

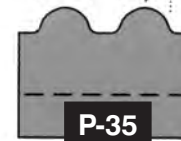

P-35



R 1/8"
 0.125" 0.125"

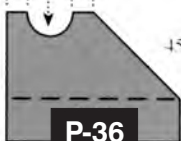

P-36



R 3/16"
 0.125" 0.063"

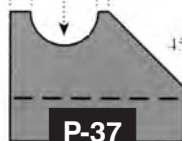

P-37



R 1/4"
 0.125" 0.063"



P-38



0.72"
 0.094" R 3/32" R 3/32"



P-39



0.565"
 0.094" R 3/32" R 1/8"



P-40



0.438"
 R 3/32" R 1/8"

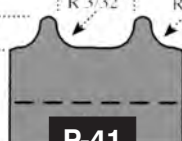

P-41

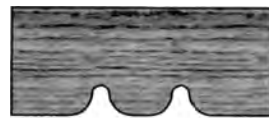

0.343"
 R 3/32" R 1/8"

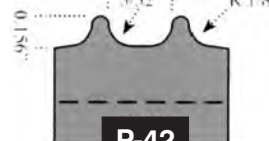

P-42



0.708"
 R 5/32"

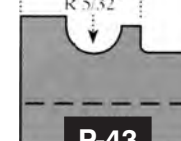

P-43



0.708"
 R 5/32"

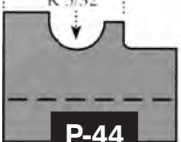

P-44



0.713"
 R 3/16"

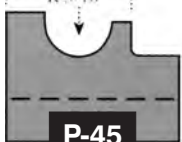

P-45



3/4" wide material

0.062" R 1/2" 0.062"



P-46



5/8" wide material
 0.093 R 0.489 0.093

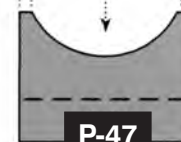

P-47



CALL TOLL FREE 1-800-443-0992 • FAX TOLL FREE 1-888-728-8665
 or visit our web site at www.ridgecarbide.com



Your Choice
\$99.00
 per pair

MAGIC MOLDER PLUGS

CARBIDE TIPPED - NOT TO SCALE

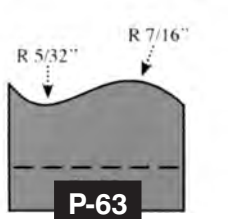
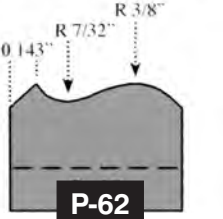
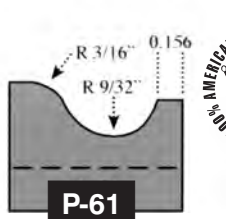
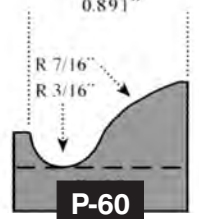
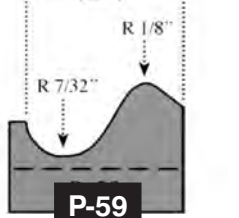
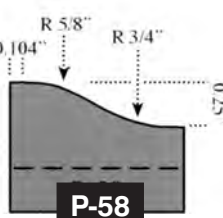
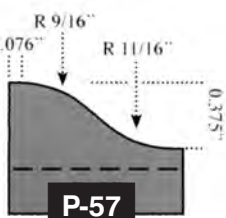
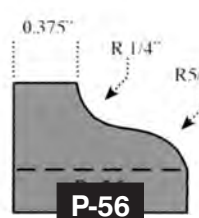
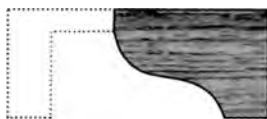
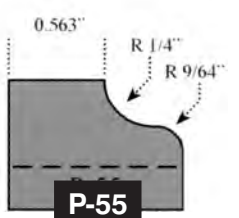
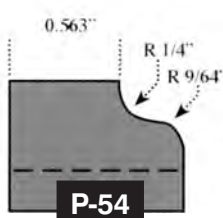
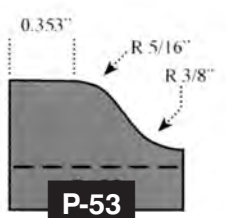
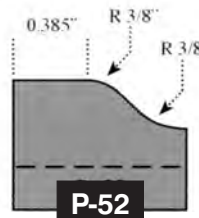
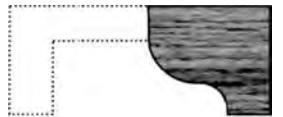
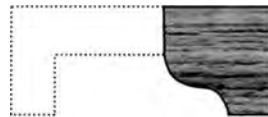
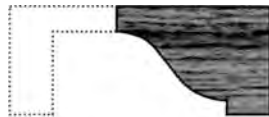
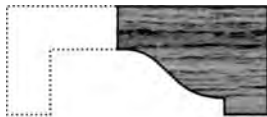
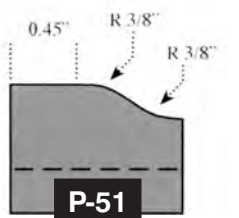
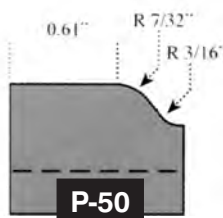
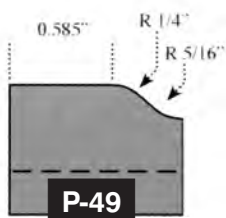
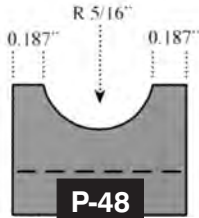
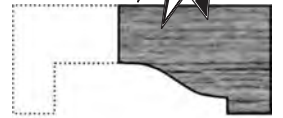
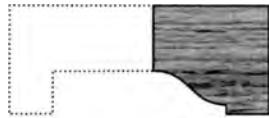

CALL TOLL FREE 1-800-443-0992 • FAX TOLL FREE 1-888-728-8665
 or visit our web site at www.ridgecarbide.com



Your Choice
\$99.00
 per pair

MAGIC MOLDER PLUGS

CARBIDE TIPPED - NOT TO SCALE

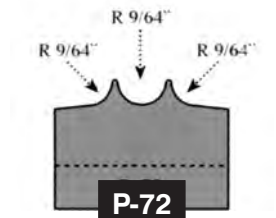
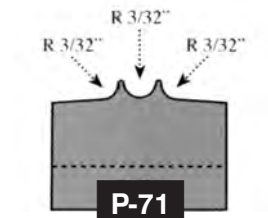
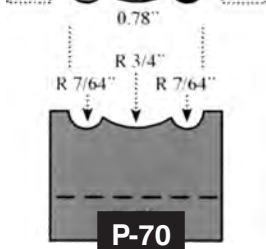
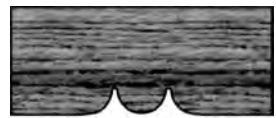
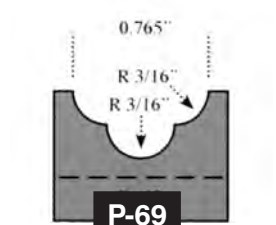
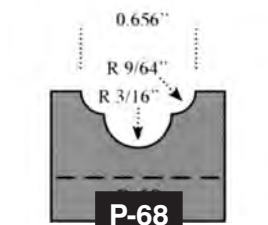
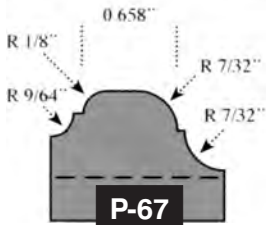
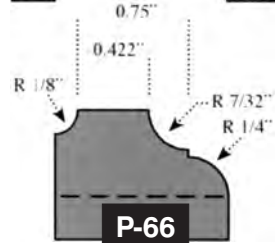
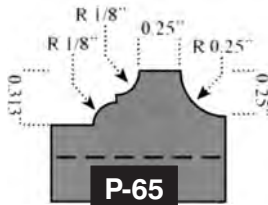
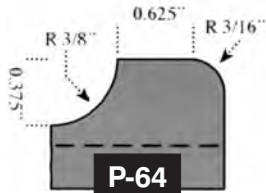

**CUSTOM PLUGS
 MADE TO ORDER
 \$250.00 PER PAIR**





CUSTOM GROUND KNIVES & CORRUGATED BACK HEADS

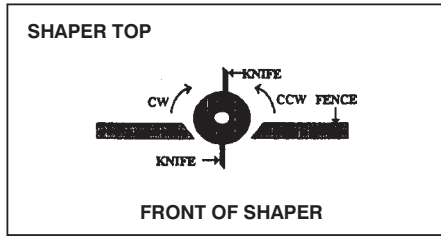
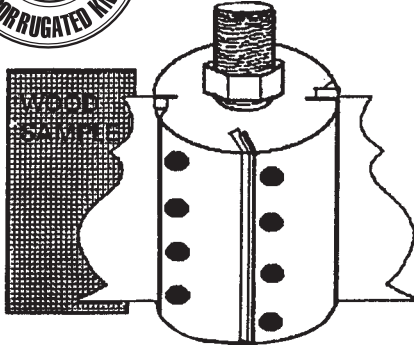

CUSTOM GROUND KNIFE PRICING PER PAIR

Finish Length To:	Corrugated	William & Hussey Shop Fox Molder Machines
2" Wide	\$126.00	\$108.00
2-1/2"	148.00	132.00
3"	159.00	159.00
3-1/2"	181.00	185.00
4"	209.00	211.00
4-1/2"	236.00	237.00
5"	258.00	264.00
5-1/2"	280.00	290.00
6"	302.00	317.00
6-1/2"	319.00	343.00

CUSTOM GROUND SMOOTH BACK JOINTER-PLANER PROFILE KNIVES FOR:

WOODMASTER, RBI, BELL SAW, JET, GRIZZLY & SEARS MACHINES

1 SINGLE KNIFE SET - \$30.00 PER INCH OF PROFILE
 3 PIECE SET - \$20.00 PER INCH OF PROFILE PER KNIFE

2-WING INDUSTRIAL STEEL CORRUGATED BACK HEADS



Machined to accept 1/4" or 5/16" corrugated back knives, 20 degree hook, 60 degree corrugations, pocket style gibbs. Maximum pattern depth 3/4"

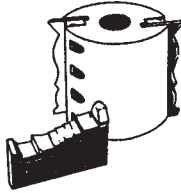

FOR SHAPER MACHINES

Head Height 2-Knife	3" Diameter 3/4" Bore	3-1/2" Diameter 1" Bore	4" Diameter 1-1/4" Bore
1"	#4300402 \$138.00	#43350402 \$144.00	
2"	#43300802 \$150.00	#43350802 \$174.00	#41400802 \$181.00
3"	#43301202 \$180.00	#43351202 \$192.00	#41401202 \$204.00
4"		#43351602 \$228.00	#41401602 \$240.00
5"			#41402002 \$258.00
6"			#41402402 \$282.00

2-KNIFE MOULDER HEADS FOR WILLIAMS & HUSSEY KNIVES



We now offer a line of cutter heads that allow you to use your existing Williams & Hussey knives on your shaper or larger high speed moulder - no need to order two sets of knives for each. Use all your existing W&H knives in these heads to match the exact profiles without having to order more corrugated back knives. Heads accept knives up to 1/4" thickness, 6000 rpm max. Heads include 3/8" bolts - placed on 1.0" centers.



2-Knife Moulder Heads for Williams & Hussey Knives

Body Diameter	4" Cutting Length	6" Cutting Length
4"	Bore Size 1-1/4" MHW100-100 \$290.00	1-1/4" MHW100-150 \$334.00
4-13/16"	Bore Size 1-1/2" MHW122-100-1.5 \$301.00	1-1/2" MHW122-150-1.5 \$349.00
4-13/16"	Bore Size 40mm MHW122-100 \$301.00	40mm MHW122-150 \$349.00

CALL TOLL FREE 1-800-443-0992 • FAX TOLL FREE 1-888-728-8665
 or visit our web site at www.ridgecarbide.com



STOCK PROFILE KNIVES/ HIGH SPEED STEEL



NOT TO SCALE

QUARTER ROUNDS

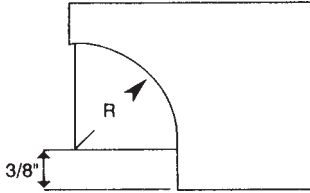

Order No.	Radius	Price
WM102	1-1/4	\$115.00
WM103	1-1/16	110.00
WM104	1	105.00
WM105	3/4	95.00
WM106	11/16	95.00
WM107	5/8	95.00
WM108	1/2	85.00
WM109	3/8	85.00
WM110	1/4	85.00

COVES

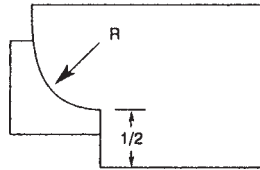

Order No.	Radius	Price
WM93	3/4	\$95.00
WM94	5/8	85.00
WM95	9/16	85.00
WM96	1/2	85.00
WM100	7/16	85.00
WM101	3/8	85.00

Standard Knives Ready to be Shipped.

Prices based on Corrugated Back and Williams & Hussey Knives and Shop Fox machines.

Smooth Back Molder Knives quoted on order.

Profiles available for Belsaw, RBI & Wood Master. See chart on page 62 for custom profiles.

BEAD & BULLNOSE KNIVES

BEDS

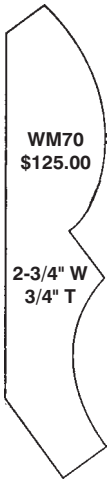

WM70
\$125.00

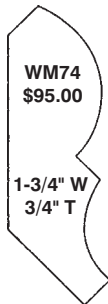

WM74
\$95.00

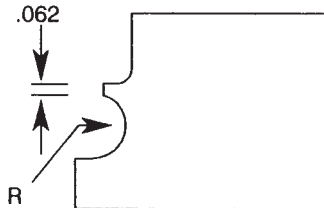

Order No.	Radius	Price
BK100	1/8	\$85.00
BK101	3/16	85.00
BK102	1/4	85.00

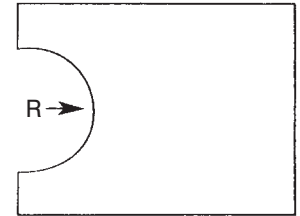

Order No.	Radius	Price
BK103	5/16	\$95.00
BK104	3/8	95.00
BK105	7/16	95.00
BK106	1/2	95.00
BK107	9/16	95.00
BK108	5/8	95.00
BK109	3/4	115.00
BK110	7/8	135.00
BK111	1	135.00

ANGLE & BACKOUT KNIVES

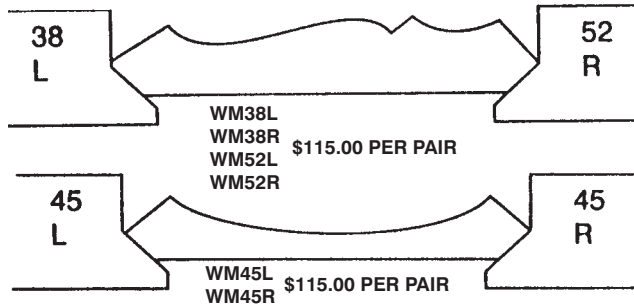

THESE KNIVES ONLY (32°, 52°, 45°)

BASE SHOES



WM126
\$85.00

3/4" W
1/2" T



WM127
\$85.00

3/4" W
7/16" T

W = WOOD WIDTH
T = WOOD THICKNESS

CALL TOLL FREE 1-800-443-0992 • FAX TOLL FREE 1-888-728-8665
or visit our web site at www.ridgecarbide.com











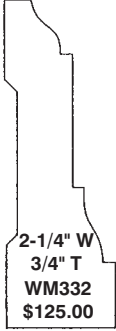
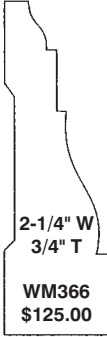

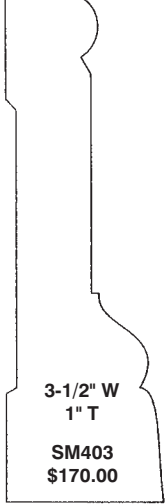

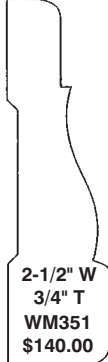
STOCK PROFILE KNIVES/ HIGH SPEED STEEL

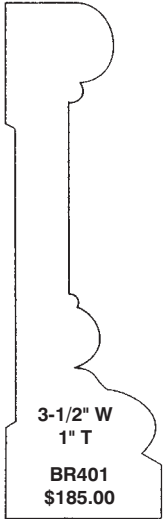
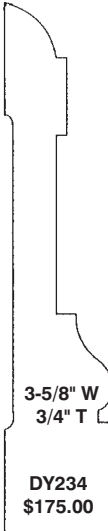
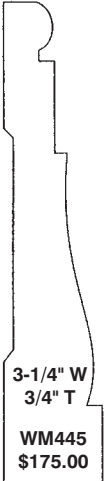
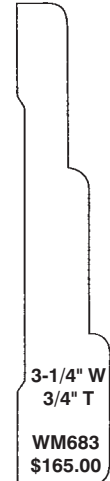

NOT TO SCALE

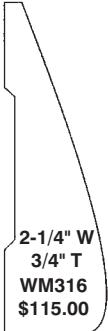
CHAIR RAIL & CASINGS

 <p>2-1/4" W 3/4" T WM332 \$125.00</p>	 <p>2-1/4" W 3/4" T WM366 \$125.00</p>	 <p>2-3/4" W 3/4" T DY233 \$150.00</p>	 <p>3-1/2" W 1" T SM403 \$170.00</p>	 <p>3-1/2" W 3/4" T WM444 \$165.00</p>	 <p>3-1/2" W 3/4" T WM448 \$165.00</p>
 <p>2-1/2" W 3/4" T WM351 \$140.00</p>	 <p>2-1/2" W 3/4" T WM371 \$140.00</p>	 <p>3-1/2" W 1" T BR401 \$185.00</p>	 <p>3-5/8" W 3/4" T DY234 \$175.00</p>	 <p>3-1/4" W 3/4" T WM445 \$175.00</p>	 <p>3-1/4" W 3/4" T WM683 \$165.00</p>
 <p>2-1/4" W 3/4" T WM356 \$140.00</p>	 <p>2-1/4" W 3/4" T WM376 \$140.00</p>	 <p>3-1/2" W 3/4" T DY255 \$170.00</p>	 <p>2-1/4" W 3/4" T WM316 \$115.00</p>	 <p>2-1/4" W 3/4" T WM329 \$115.00</p>	 <p>2-1/2" W 3/4" T WM315 \$115.00</p>

W = WOOD WIDTH
T = WOOD THICKNESS

CALL TOLL FREE 1-800-443-0992 • FAX TOLL FREE 1-888-728-8665
or visit our web site at www.ridgecarbide.com



STOCK PROFILE KNIVES/ HIGH SPEED STEEL



NOT TO SCALE

CHAIR RAIL

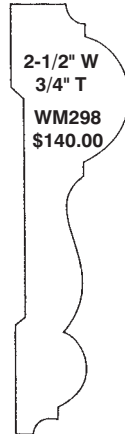
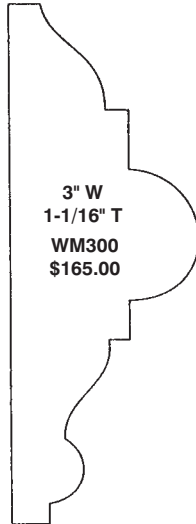
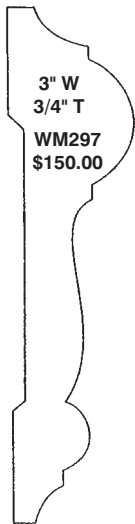
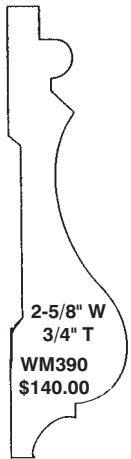

W = WOOD WIDTH
T = WOOD THICKNESS

PICTURE MOULDINGS

BASE MOULDINGS & STOPS

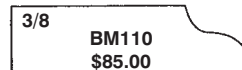
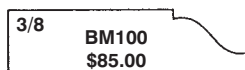
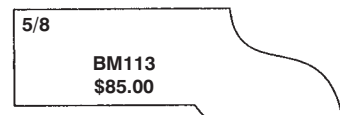
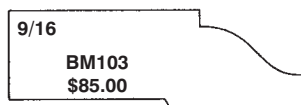
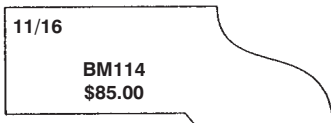
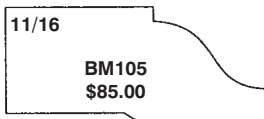
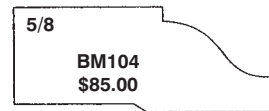
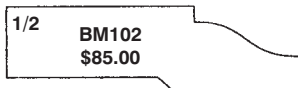
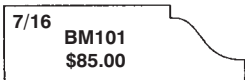
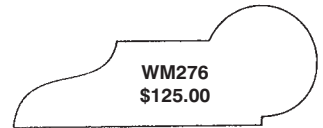
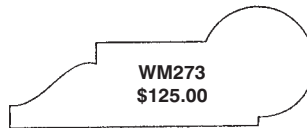

CALL TOLL FREE 1-800-443-0992 • FAX TOLL FREE 1-888-728-8665
or visit our web site at www.ridgecarbide.com



STOCK PROFILE KNIVES/ HIGH SPEED STEEL



NOT TO SCALE

CROWNS

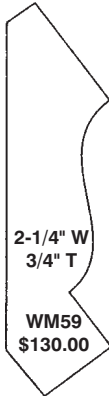
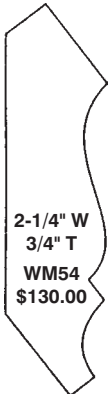
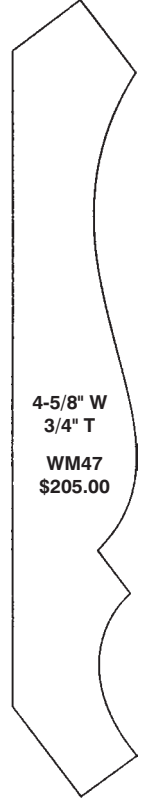
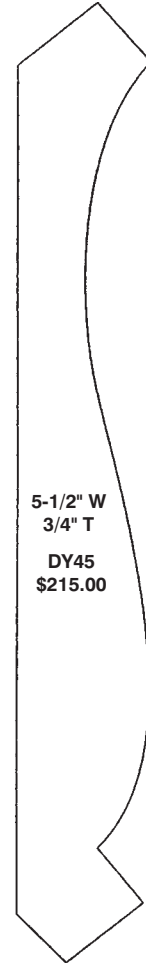
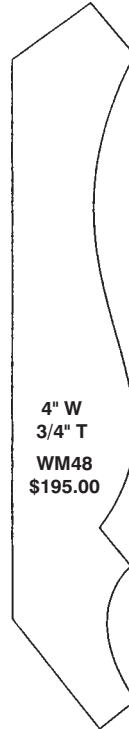
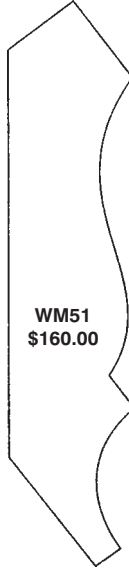
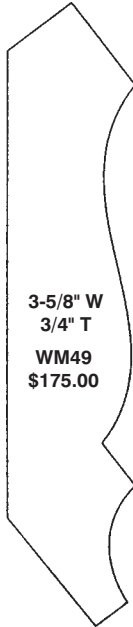
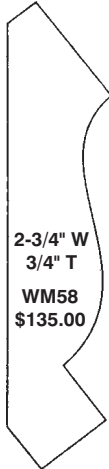
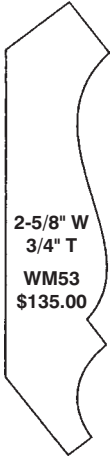

W = WOOD WIDTH
T = WOOD THICKNESS

COVES

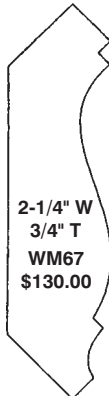

Custom Profiles
Made To Order
See Page 62.

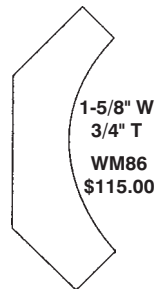
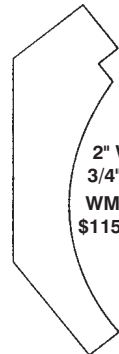

CALL TOLL FREE 1-800-443-0992 • FAX TOLL FREE 1-888-728-8665
or visit our web site at www.ridgecarbide.com



STOCK PROFILE KNIVES/ HIGH SPEED STEEL



NOT TO SCALE

SOLID CROWNS

<p>7/8" W 11/16" T DY191 \$95.00</p>	<p>1-1/8" W 11/16" T DY192 \$95.00</p>	<p>1-1/8" W 11/16" T DY193 \$105.00</p>	<p>1-3/8" W 11/16" T DY194 \$95.00</p>	<p>1-3/4" W 1-3/8" T DY195 \$115.00</p>	<p>1-3/4" W 3/4" T DY202 \$115.00</p>	<p>1-3/4" W 1-1/8" T DY203 \$115.00</p>
--	--	---	--	---	---	---

CROWN MOULDING

<p>2-1/4" W 1-1/8" T DY204 \$165.00</p>	<p>2-1/4" W 1-3/8" T DY205 \$170.00</p>	<p>3-5/8" W 3/4" T DY184 \$159.00</p>	<p>4-5/8" W 3/4" T DY185 \$195.00</p>	<p>5-1/2" W 3/4" T DY201 \$215.00</p>
---	---	---	---	---

SHINGLE PANEL MOLDINGS

<p>2-1/2" W 11/16" T WM207 \$130.00</p>	<p>2-1/2" W 11/16" T WM212 \$130.00</p>	<p>2" W 9/16" T WM213 \$120.00</p>	<p>1-3/4" W 11/16" T WM217 \$120.00</p>	<p>1-1/2" W 11/16" T WM218 \$120.00</p>
---	---	--	---	---

STOOLS

<p>1-1/16" T WM116 \$110.00</p>	<p>11/16" T WM119 \$110.00</p>
---	--

W = WOOD WIDTH
T = WOOD THICKNESS



STOCK PROFILE KNIVES/ HIGH SPEED STEEL



PANEL & FLOORING KNIVES

V-PANELS



TONGUE & GROOVE



FLOORING KNIVES

BACKOUT FOR 2-1/4" FLOORING
TGB116 \$125.00



WINDOW SASH CUTTERS

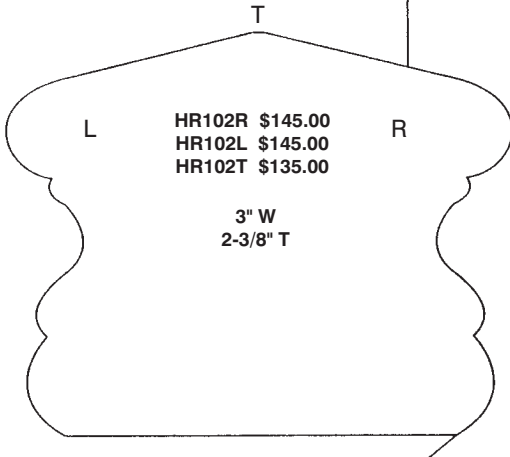
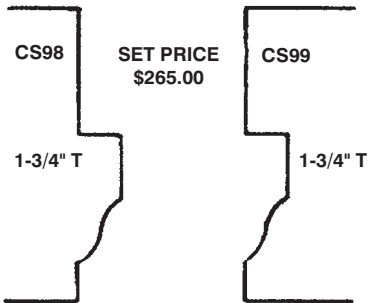

HAND RAILS

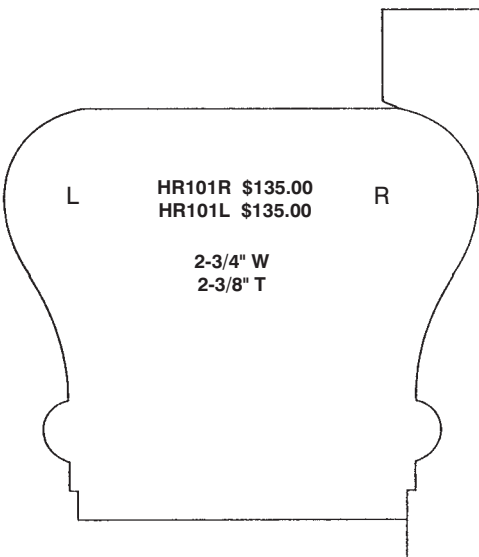

6010 HAND RAIL

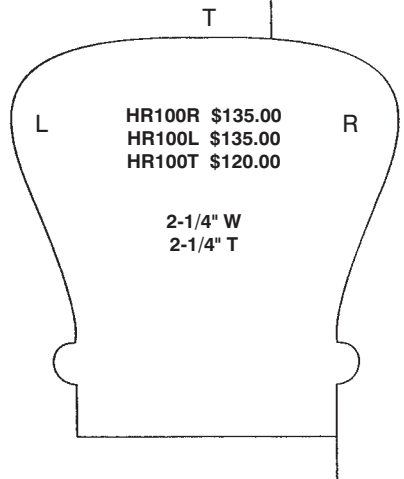

NOT TO SCALE

W = WOOD WIDTH
T = WOOD THICKNESS

CALL TOLL FREE 1-800-443-0992 • FAX TOLL FREE 1-888-728-8665
or visit our web site at www.ridgecarbide.com



M2+ - HSS - JOINTER & PLANER KNIFE SETS

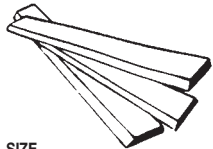

PLEASE SPECIFY THE NUMBER OF KNIVES NEEDED FOR EACH SET.

Some of Our Most Popular Knife Set Sizes
Call For Other Sizes

SIZE	OLD NUMBER	KNIVES IN SET	PART NUMBER	MACHINES	LIST PRICE PER SET
2-1/4 x 1 x 3/16	NEW!	1	1000	POWERMATIC QUIET HEAD	\$21.95
4 x 19/32 x 3/32	JP01	3	1001	DELTA 4" 37-290, WALKER TURNER	27.95
4 x 5/8 x 1/8	JP02	3	1004	JET JJ-4, ATLAS, BOICE, CRAFTSMAN	28.95
4 x 3/4 x 1/8	JP03	3	1007	GRIZZLY 4", 3 KNIFE HEAD	27.95
4 x 7/8 x 1/8	NEW!	3	1010	HUTCHINSON	28.95
4-3/8 x 11/16 x 1/8	JP04	3	1016	CRAFTSMAN	29.95
5-1/16 x 3/4 X 1/8	NEW!	3	1019	DURO	29.95
6 x 5/8 x 1/16	NEW!	4	1022	CRESCENT J-6	49.95
6 x 5/8 x 1/8	JP05	3	1025	JET JJ-6, DELTA ROCKWELL, BOICE, TTL, SUNHILL, WOODTEK	40.95
6 x 5/8 x 1/8	JP06	4	1028	BOICE	48.95
6 x 11/16 x 1/8	NEW!	3	1031	BRIDGEWOOD, YORKCRAFT	48.95
6 x 3/4 x 1/8	JP07	3	1034	POWERMATIC 50, CRESCENT, ATLAS	40.95
6 x 3/4 x 1/8	NEW!	4	1037	IMPORTS	49.95
6 x 7/8 x 1/8	JP08	3	1040	HUTCHINSON, POWERMATIC 50	40.95
6 x 1 x 1/8	JP09	3	1043	GRIZZLY 6"	40.95
6-1/16 x 5/8 x 3/32	JP10	3	1046	YATES, J-LINE	40.95
6-1/16 x 5/8 x 1/8	NEW!	3	1049	POWERMATIC 54A, JET, JJ-6	42.95
6-1/16 x 3/4 x 1/8	JP11	3	1052	WALKER-TURNER, WALLACE	40.95
6-1/16 x 13/16 x 1/8	NEW!	3	1055	DELTA DJ-15, DELTA 37-154	42.95
6-1/8 x 19/32 x 3/32	NEW!	3	1058	DELTA 37-658, 37-205, 37-220, 37-190, 37-195	40.95
6-1/8 x 5/8 x 3/32	JP12	3	1061	CRAFTSMAN	42.95
6-1/8 x 5/8 x 1/8	JP13	3	1064	CRAFTSMAN	40.95
6-1/8 x 3/4 x 1/8	JP14	3	1067	DURO	40.95
6-1/4 x 1 x 1/8	NEW!	3	1070	OLIVER 133	42.95
8 x 5/8 x 1/16	JP17	4	1076	DELTA 37-301, CRESCENT	64.95
8 x 19/32 x 3/32	JP16	3	1079	WALKER-TURNER	54.95
8 x 5/8 x 1/8	JP18	3	1082	POWERMATIC 60, DELTA ROCKWELL, JET JJ-8 WOODTEK, BOICE, TTL	49.95
8 x 5/8 x 1/8	JP19	4	1085	BOICE CRANE	59.95
8 x 11/16 x 1/8	NEW!	3	1088	JET JJ-8	62.95
8 x 3/4 x 1/8	JP20	3	1091	POWERMATIC 60, PRYOR, SUNHILL	49.95
8 x 3/4 x 1/8	JP21	4	1094	BRIDGEWOOD	64.95
8 x 7/8 x 1/8	JP22	3	1097	POWERMATIC	49.95
8 x 1 x 1/8	JP24	3	1100	GRIZZLY 8", OLIVER	49.95
8 x 1-1/8 x 1/8	NEW!	4	1103	CRESCENT	64.95
8 x 1-1/4 x 1/8	JP23	4	1106	NORTHFIELD	64.95
8-1/16 x 19/32 x 3/32	NEW!	3	1109	DELTA 37-315	62.95
8-1/16 x 5/8 x 3/32	JP25	3	1112	YATES, J-LINE	49.95
8-1/16 x 3/4 x 1/8	NEW!	4	1113	SUNHILL	64.95
8-1/16 x 13/16 x 1/8	JP26	3	1115	DELTA DJ-20, 37-365	62.95
8-1/16 x 7/8 x 1/8	NEW!	4	1118	WALLACE	62.95
8-3/8 x 11/16 x 1/8	JP27	3	1121	FOLEY-BELSAW	49.95
8-1/8 x 1-1/8 x 5/32	NEW!	3	1124	YATES	64.95
8-1/4 x 1 x 1/8	NEW!	3	1127	OLIVER	62.95
11.81" (300MM) x 30MM x 3MM	JP28	3	1130	SCMI	95.95
12 x 5/8 x 1/8	JP29	3	1133	POWERMATIC	71.95
12 x 3/4 x 1/8	NEW!	2	1136	GRIZZLY 12"	62.95
12 x 3/4 x 1/8	JP30	3	1139	CRAFTSMAN	72.95
12 x 7/8 x 1/8	JP31	3	1142	POWERMATIC 100, PARKS, WOODTEK	76.95
12 x 1 x 1/8	JP32	3	1145	CRAFTSMAN	76.95
12 x 1-1/8 x 1/8	JP35	2	1148	JET JJ-12	51.95
12 x 1-1/8 x 1/8	JP34	3	1151	GRIZZLY 12"	76.95
12 x 1-1/8 x 1/8	NEW!	4	1154	BRIDGEWOOD, GRIZZLY 12", CRESCENT	95.95
12 x 1-1/8 x 1/8	NEW!	4	1157	YATES B101	95.95
12 x 1-1/4 x 1/8	NEW!	3	1160	OLIVER, NORTHFIELD	76.95
12 x 1-1/4 x 1/8	JP33	4	1163	NORTHFIELD	95.95
12 x 1-3/8 x 1/8	JP37	3	1166	POWERMATIC FS-305, OLIVER 166	76.95
12 x 1-1/8 x 5/32	NEW!	3	1169	YATES	85.95

***FOR MACHINES AND SIZES NOT LISTED HERE - PLEASE CALL**

CALL TOLL FREE 1-800-443-0992 • FAX TOLL FREE 1-888-728-8665
or visit our web site at www.ridgecarbide.com



M2+ - HSS - JOINTER & PLANER KNIFE SETS

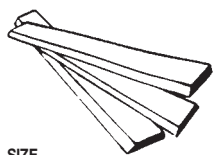

PLEASE SPECIFY THE NUMBER OF KNIVES NEEDED FOR EACH SET.

Some of Our Most Popular Knife Set Sizes
Call For Other Sizes

SIZE	OLD NUMBER	KNIVES IN SET	PART NUMBER	MACHINES	LIST PRICE PER SET
12 x 1-1/2 x 5/32	NEW!	4	1172	NEWMAN, FAY & EGAN, RED FOX	\$116.95
12-1/16 x 1-1/8 x 5/32	JP38	3	1175	YATES J-139	86.95
12-1/8 x 1-1/8 x 1/8	JP39	3	1178	POWERMATIC	85.95
12-1/4 x 5/8 x 1/8	JP40	3	1181	BOICE CRANE	74.95
12-1/4 x 3/4 x 1/8	NEW!	3	1184	WILKE, BOICE, RELIANT	79.95
12-1/4 x 7/8 x 1/8	JP41	3	1187	POWERMATIC 100	79.95
12-1/4 x 1 x 1/8	JP42	3	1190	PARKS, BOICE, MOST EURO. COMBINATION MACHINES	85.95
12-1/2 x 5/8 x 1/8	NEW!	2	1193	JET JWP-12	64.95
12-1/2 x 5/8 x 1/8	JP44	3	1196	BOICE CRANE	74.95
12-1/2 x 11/16 x 1/8	NEW!	2	1199	FOLEY-BELSAW	59.95
12-1/2 x 11/16 x 1/8	JP46	3	1202	FOLEY-BELSAW, WOODMASTER 712, POWERMATIC, RBI, JET	79.95
12-1/2 x 3/4 x .070	JP43	2	1208	(DOUBLE EDGED) DELTA 22-540C	59.95
12-1/2 x 3/4 x 1/8	JP47	2	1211	GRIZZLY 12-1/2"	64.95
12-1/2 x 7/8 x 1/8	NEW!	3	1214	POWERMATIC 12	74.95
13 x 7/8 x 1/8	JP48	4	1220	PARKS	94.95
13-1/16 X 5/8 X 1/8	JP49	3	1223	DELTA, JET JPM-13, GRIZZLY 13"	76.95
13-1/16 x 7/8 x 1/8	NEW!	2	1226	WOODTEK	69.95
13-1/8 x 11/16 x 5/32	JP50	3	1228	(NO SLOTS) DELTA 22-401	94.95
13-1/8 x 11/16 x 5/32	NEW!	3	1229	(WITH END SLOTS) DELTA 22-401	97.95
13-1/8 x 1 x 1/8	JP51	3	1232	DELTA RC-33 DC-33, ROCKWELL	84.95
13.78" (350MM) x 30MM X 3MM	JP52	3	1235	SCMI	118.95
14 x 1-1/2 x 5/32	NEW!	4	1238	NEWMAN 18	126.95
14 x 1-3/4 x 5/32	JP53	4	1241	NEWMAN 500	145.95
14-1/4 x 3/4 x 1/8	NEW!	4	1244	CRESCENT	126.95
15 x 1 x 1/8	JP54	3	1250	DELTA 380, JET JWP-15, GRIZZLY, POWERMATIC 15, WOODTEK, MOST 15" IMPORTED PLANERS	87.95
15 x 1 x 1/8 (2 BEVELS)	NEW!	3	1253	POWERMATIC 15 AND MANY 15" PLANERS (2 BEVELS)	142.95
15 x 1/3/4 x 5/32	JP56	3	1256	STETSON ROSS	108.95
15 x 2 x 5/32	JP57	3	1259	STETSON ROSS	108.95
15-1/8 x 1 x 1/8	NEW!	3	1262	DELTA 22-677	92.95
15-5/16 x 5/8 x 1/8	NEW!	3	1265	POWERMATIC PM-15	97.95
16 x 1 x 1/8	JP59	3	1268	JET JWP-16	116.95
16 x 1-1/8 x 1/8	JP63	4	1271	BRIDGEWOOD, GRIZZLY 16", CRESCENT	136.95
16 x 1-1/4 x 1/8	JP62	3	1274	NORTHFIELD 16 HD	109.95
16 x 1-1/4 x 1/8	NEW!	4	1277	NORTHFIELD 16 PM, GENERAL	131.95
16 x 1-1/2 x 1/8	JP64	3	1280	PORTER 300	119.95
16 x 1-1/8 x 5/32	NEW!	3	1283	YATES M-31	126.95
16 x 1-1/4 x 5/32	JP68	3	1286	TOWSLEY	119.95
16 x 1-3/8 x 5/32	JP66	3	1289	MOAK	122.95
16 x 1-1/2 x 5/32	JP67	3	1292	NEWMAN 60, VANCE 66	122.95
16 x 1-3/4 x 5/32	NEW!	3	1295	NEWMAN 510 512, FAY & EGAN	122.95
16-1/8 x 1 x 1/8	NEW!	3	1298	JET JWP-160S	116.95
16.14" (410MM) x 30MM x 3MM	NEW!	4	1301	SCMI 410	153.95
16-1/4 x 1-1/4 x 5/32	JP68	3	1304	POWERMATIC 160	119.95
16-1/2 x 11/16 x 1/8	NEW!	4	1307	RBI 816	126.95
16-21/32 x 1-3/8 x 1/8	NEW!	4	1310	DELTA 37-420 RJ-42	156.95
17 x 1-1/4 x 1/8	JP69	4	1313	POWERMATIC FS-430	149.95
18 x 3/4 x 1/8	NEW!	4	1316	CRESCENT	159.95
18 x 7/8 x 1/8	JP70	3	1319	DELTA CRESCENT	119.95
18 x 1-1/8 x 5/32	JP71	3	1322	YATES J-188	126.95
18 x 1-1/4 x 5/32	JP73	3	1325	POWERMATIC	126.95
18-1/8 x 1-1/8 x 5/32	JP71	3	1328	DELTA 22-212, ROCKWELL, YATES J180	126.95
18-1/8 x 1-1/8 x 5/32	JP76	4	1331	YATES J-180	174.95
18-1/4 x 3/4 x 1/8	NEW!	4	1334	DELTA CRESCENT	156.95
18-1/4 x 1-1/4 x 5/32	JP74	3	1337	POWERMATIC 180	127.95
18-3/8 x 1 x 1/8	NEW!	3	1340	OLIVER 399	127.95
18-1/2 x 11/16 x 1/8	JP44	3	1343	WOODMASTER 718	127.95
18-1/2 x 1-1/8 x 5/32	NEW!	4	1346	NORTHFIELD	174.95

* FOR MACHINES AND SIZES NOT LISTED HERE - PLEASE CALL

CALL TOLL FREE 1-800-443-0992 • FAX TOLL FREE 1-888-728-8665
 or visit our web site at www.ridgecarbide.com



M2+ - HSS - JOINTER & PLANER KNIFE SETS

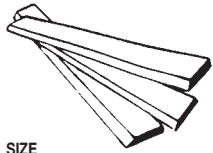

PLEASE SPECIFY THE NUMBER OF KNIVES NEEDED FOR EACH SET.

Some of Our Most Popular Knife Set Sizes
Call For Other Sizes

SIZE	OLD NUMBER	KNIVES IN SET	PART NUMBER	MACHINES	LIST PRICE PER SET
20 x 1 x 1/8	JP79	3	1349	NORTHWOOD	\$119.95
20 x 1 x 1/8	JP80	4	1352	GRIZZLY 20", JET 208, SUNHILL, POWERMATIC 209, PARKS, TTL, NORTHSTATE	142.95
20 x 1-1/8 x 1/8	NEW!	3	1355	BRIDGEWOOD	127.95
20 x 1-1/8 x 1/8	JP81	4	1358	CRESCENT, DELTA 20 x 9, MANY EUROPEAN MACHINES	163.95
20 x 1-3/16 x 1/8	NEW!	3	1361	GRIZZLY 20" (3) G 6704	127.95
20 x 1-3/16 x 1/8	NEW!	4	1364	GRIZZLY 20" (4) H 7269	163.95
20 x 1-1/4 x 1/8	JP82	3	1370	WOODTEK 20"	138.95
20-3/16 x 1-3/16 x 1/8	NEW!	3	1373	DELTA DC-580	138.95
20-3/16 x 1-3/8 x 1/8	JP83	4	1376	DELTA RC-51 22-460	171.95
20-1/4 x 1-1/4 x 5/32	JP84	3	1379	POWERMATIC 221	133.95
20.47" (520MM) x 30MM x 3MM	JP87	4	1385	SCMI 520 550 552	189.95
20-1/2 x 11/16 x 1/8	NEW!	4	1385	RBI 820	174.95
22 x 1-1/2 x 5/32	NEW!	4	1388	NEWMAN 8B	229.95
22-1/8 x 7/8 x 1/8	NEW!	4	1391	POWERMATIC 201	187.95
24 x 1 x 1/8	NEW!	3	1394	NORTHWOOD	154.95
24 x 1-1/8 x 1/8	JP89	4	1397	CRESCENT	187.95
24 x 1-1/8 x 1/8	NEW!	4	1400	BRIDGEWOOD, NORTHFIELD	187.95
24 x 1-3/16 x 1/8	NEW!	3	1403	GRIZZLY 24"	154.95
24 x 1-1/4 x 1/8	NEW!	3	1406	SECO	154.95
24 x 1-1/4 x 1/8	NEW!	4	1409	NORTHFIELD	187.95
24 x 1-3/8 x 1/8	JP90	4	1412	BUSS 4L 248, OLIVER	187.95
24 x 1-1/8 x 5/32	JP92	3	1415	YATES B-44, FAY & EGAN	165.95
24 x 1-1/4 x 5/32	JP91	4	1418	POWERMATIC, NORTHFIELD	198.95
24 x 1-3/8 x 5/32	JP93	3	1421	FAY & EGAN	165.95
24-1/4 x 1-1/8 x 1/8	NEW!	3	1424	DELTA 22-470	154.95
24-1/4 x 1-1/8 x 1/8	NEW!	4	1427	CRESCENT	188.95
24-1/4 x 1-1/4 x 1/8	JP98	4	1430	NORTHFIELD	188.95
24-1/4 x 1-1/2 x 1/8	NEW!	3	1433	PORTER	151.95
24-1/4 x 1-1/4 x 5/32	JP99	4	1436	POWERMATIC 225, NEWMAN 600	209.95
24-5/16 x 1-1/8 x 1/8	NEW!	4	1439	WHITNEY P-4	192.95
24-5/16 x 1-1/4 x 1/8	JP101	4	1442	WHITNEY 105	187.95
24-1/2 x 1-1/8 x 1/8	JP103	3	1445	OLIVER 199 229D	154.95
24-1/2 x 1-1/4 x 5/32	JP104	4	1448	OLIVER 199 E	209.95
24-3/4 x 1-1/8 x 1/8	JP105	3	1451	JET 24H	151.95
24-13/16 x 1-3/8 x 1/8	NEW!	4	1454	DELTA RC-63 22-610	187.95
25 x 11/16 x 1/8	JP106	3	1457	WOODMASTER 725	165.95
25 x 1-1/4 x 5/32	JP107	4	1460	NORTHFIELD	209.95
25.2" (640MM) x 35MM x 3MM	NEW!	4	1463	SCMI F535 630	225.95
26 x 1-3/8 x 1/8	JP108	4	1446	BUSS 4L	249.95
30 x 1-3/8 x 1/8	JP109	4	1469	BUSS 8A 66 88	249.95
30 x 1-1/4 x 1/8	JP110	4	1472	YATES B-8	229.95
30 x 1-3/8 x 5/32	JP111	4	1475	BUSS	279.95
30 x 1-1/2 x 1/8	JP113	3	1478	PORTER	187.95
30 x 1-1/2 x 5/32	JP112	3	1481	FAY & EGAN	204.95
30-1/8 x 1-3/4 x 5/32	JP115	4	1484	YATES 177	269.95
30-5/16 x 1-3/8 x 1/8	JP114	4	1487	WHITNEY 97 324 24A	242.95
32-5/16 x 1-1/2 x 1/8	NEW!	4	1490	WHITNEY 33 37	288.95
36 x 1-3/8 x 1/8	JP116	4	1493	WHITNEY	297.95
36 x 1-1/2 x 1/8	NEW!	4	1496	BUSS MASTER P 44 66 88	288.95
36-1/8 x 1-1/8 x 1/8	NEW!	4	1499	WHITNEY 29A	288.95
36-1/4 x 1-1/2 x 1/8	JP117	4	1502	PORTER	297.95
36-5/16 x 1-3/8 x 5/32	JP119	4	1505	WHITNEY	319.95
40 x 1-3/8 x 1/8	NEW!	4	1508	BUSS 44 66 88	363.95
40 x 1-1/2 x 1/8	NEW!	3	1511	PORTER	272.95
40-5/16 x 1-1/8 x 1/8	NEW!	4	1514	WHITNEY 24	349.95
44 x 1-1/8 x 1/8	NEW!	4	1517	WHITNEY 27	382.95

* FOR MACHINES AND SIZES NOT LISTED HERE - PLEASE CALL

CALL TOLL FREE 1-800-443-0992 • FAX TOLL FREE 1-888-728-8665
 or visit our web site at www.ridgecarbide.com



CARBIDE TIPPED PLANER & JOINTER KNIFE SETS



PLEASE SPECIFY THE NUMBER OF KNIVES NEEDED FOR EACH SET.

Some of Our Most Popular Knife Set Sizes

Call For Other Sizes

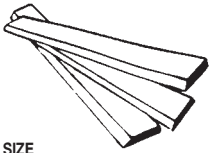

SIZE	KNIVES IN SET	PART NUMBER	MACHINES	LIST PRICE PER SET
4 x 19/32 x 3/32	3	3001	DELTA, WALKER-TURNER	\$89.95
4 x 5/8 x 1/8	3	3004	BOICE CRANE, ATLAS, JET JJ-4, CRAFTSMAN, GRIZZLY	89.95
4-3/8 x 11/16 x 1/8	3	3007	CRAFTSMAN	139.95
6 x 5/8 x 1/8	3	3010	ROCKWELL, JET JJ-6, BOICE, WOODTEK, TTL, SUNHILL, BRIDGEWOOD	126.95
6 x 5/8 x 1/8	4	3013	BOICE CRANE	169.95
6 x 3/4 x 1/8	3	3016	POWERMATIC 50, CRESCENT, ATLAS	169.95
6 x 3/4 x 1/8	4	3019	IMPORTS	236.95
6 x 7/8 x 1/8	3	3022	POWERMATIC 50, HUTCHINSON	169.95
6 x 1 x 1/8	3	3025	GRIZZLY	179.95
6-1/16 x 5/8 x 3/32	3	3028	YATES, J-LINE	169.95
6-1/16 x 5/8 x 1/8	3	3031	POWERMATIC 54A, JET JJ-6	169.95
6-1/16 x 3/4 x 1/8	3	3034	WALKER-TURNER, WALLACE	169.95
6-1/16 x 13/16 x 1/8	3	3037	DELTA DJ-15, 37-154	169.95
6-1/8 x 19/32 x 3/32	3	3040	DELTA 37-658, 37-205, 37-220, 378-190, 37-195	169.95
6-1/8 x 5/8 x 3/32	3	3043	CRAFTSMAN	169.95
6-1/8 x 5/8 x 1/8	3	3046	CRAFTSMAN	169.95
6-1/8 x 3/4 x 1/8	3	3049	DURO	169.95
6-1/4 x 1 x 1/8	3	3052	OLIVER 133	179.95
8 x 19/32 x 3/32	3	3055	WALKER-TURNER	234.95
8 x 5/8 x 1/8	3	3058	DELTA, POWERMATIC 60, JET JJ-8, WOODTEK, BOICE, TTL	169.95
8 x 5/8 x 1/8	4	3061	BOICE CRANE	224.95
8 x 11/16 x 1/8	3	3064	JET JJ-8	236.95
8 x 3/4 x 1/8	3	3067	POWERMATIC, PRYOR, SUNHILL	169.95
8 x 3/4 x 1/8	4	3070	BRIDGEWOOD	224.95
8 x 7/8 x 1/8	3	3073	POWERMATIC	234.95
8 x 1 x 1/8	3	3076	OLIVER, GRIZZLY 8"	244.95
8 x 1-1/4 x 1/8	4	3079	NORTHFIELD	286.95
8-1/16 x 5/8 x 3/32	3	3082	DELTA 37-315, YATES, J-LINE	234.95
8-1/16 x 3/4 x 1/8	3	3085	DELTA DJ-20 37-365	247.95
12 x 5/8 x 1/8	3	3088	POWERMATIC	292.95
12 x 3/4 x 1/8	2	3091	GRIZZLY 12"	143.95
12 x 3/4 x 1/8	3	3094	CRAFTSMAN	295.95
12 x 7/8 x 1/8	3	3097	POWERMATIC, PARKS, WOODTEK	296.95
12 x 1 x 1/8	3	3100	CRAFTSMAN	305.95
12 x 1-1/8 x 1/8	2	3103	JET JJ-12	240.95
12 x 1-1/8 x 1/8	3	3106	GRIZZLY 12"	358.95
12 x 1-1/8 x 1/8	4	3109	GRIZZLY, BRIDGEWOOD, CRESCENT	478.95
12 x 1-1/4 x 1/8	3	3112	NORTHFIELD, OLIVER	358.95
12 x 1-1/4 x 1/8	4	3115	NORTHFIELD	478.95
12 x 1-3/8 x 5/32	3	3118	FAY & EGAN, NEWMAN, RED FOX	391.95
12 x 1-3/8 x 1/8	3	3121	POWERMATIC FS 305, OLIVER 166	382.95
12-1/4 x 5/8 x 1/8	3	3124	BOICE CRANE	297.95
12-1/4 x 3/4 x 1/8	3	3127	WILKE, BOICE, RELIANT	302.95
12-1/4 x 7/8 x 1/8	3	3130	POWERMATIC 100	302.95
12-1/4 x 1 x 1/8	3	3133	PARKS, BOICE CRANE, MOST EURO. COMBINATION MACHINES	311.95
12-1/2 x 11/16 x 1/8	3	3136	FOLEY-BELSAW, RBI, WOODMASTER, POWERMATIC, JET	373.95
12-1/2 x 3/4 x 1/8	2	3139	GRIZZLY	206.95
12-1/2 x 7/8 x 1/8	3	3142	BELSAW, POWERMATIC 12	206.95
13 x 7/8 x 1/8	4	3145	PARKS	427.95
13-1/16 x 5/8 x 1/8	3	3147	JET JPM-13, GRIZZY, DELTA	372.95
13-1/8 x 11/16 x 5/32	3	3148	DELTA ROCKWELL (WITH SLOTS)	432.95
13-1/8 x 1 x 1/8	3	3151	DELTA RC-33, DC-33, ROCKWELL	422.95
15 x 1 x 1/8	3	3154	DELTA 380, JET JWP-15, GRIZZLY, POWERMATIC 15", 15" MOST IMPORTS	423.95
16 x 1 x 1/8	3	3157	JET JWP-16	463.95
16 x 1-1/8 x 1/8	4	3163	BRIDGEWOOD, GRIZZLY 16", CRESCENT	560.95
16 x 1-1/4 x 1/8	3	3166	NORTHFIELD 16HD	473.95
16 x 1-1/4 x 1/8	4	3169	NORTHFIELD 16PM, GENERAL	560.95
16 x 1-1/4 x 5/32	3	3172	TOWSLEY	478.95
16-14" (410 MM) x 30MM x 3 MM	4	3175	SCMI 410	573.95
16-1/4 x 1-1/4 x 5/32	3	3178	POWERMATIC 160	436.95
16-1/2 x 11/16 x 1/8	4	3181	RBI 816	542.95
16-21/32 x 1-3/8 x 1/8	4	3184	DELTA 37-420, RJ-42	721.95
17 x 1-1/4 x 1/8	4	3187	POWERMATIC FS-430	677.95

* FOR MACHINES AND SIZES NOT LISTED - PLEASE CALL

CALL TOLL FREE 1-800-443-0992 • FAX TOLL FREE 1-888-728-8665
 or visit our web site at www.ridgecarbide.com



CARBIDE TIPPED PLANER & JOINTER KNIFE SETS



PLEASE SPECIFY THE NUMBER OF KNIVES NEEDED FOR EACH SET.

Some of Our Most Popular Knife Set Sizes

Call For Other Sizes

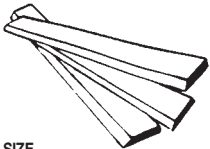

SIZE	KNIVES IN SET	PART NUMBER	MACHINES	LIST PRICE PER SET
18 x 3/4 x 1/8	4	3190	CRESCENT	\$592.95
18 x 7/8 x 1/8	3	3193	DELTA CRESCENT	443.95
18 x 1-1/8 x 5/32	3	3196	YATES J188	537.95
18 x 1-1/4 x 5/32	3	3199	POWERMATIC	561.95
18-1/8 x 1-1/8 x 5/32	3	3202	DELTA 22-212, NORTHFIELD, YATES J180	541.95
18-1/4 x 3/4 x 1/8	4	3205	DELTA CRESCENT	601.95
18-1/4 x 1-1/4 x 5/32	3	3208	POWERMATIC 180	573.95
18-3/8 x 1 x 1/8	3	3211	OLIVER 399	467.95
18-1/2 x 11/16 x 1/8	3	3214	WOODMASTER 718	456.95
18-1/2 x 1-1/8 x 5/32	3	3217	NORTHFIELD	552.95
20 x 1 x 1/8	3	3220	NORTHWOOD	495.95
20 x 1 x 1/8	4	3223	JET 208, GRIZZLY, POWERMATIC 209, PARKS, TTL	659.95
20 x 1-1/8 x 1/8	3	3226	BRIDGEWOOD	597.95
20 x 1-1/8 x 1/8	4	3229	CRESCENT, DELTA 20 x 9, MANY EUROPEAN MACHINES	797.95
20 x 1-3/16 x 1/8	3	3232	GRIZZLY 20", IMPORTS	597.95
20 x 1-3/16 x 1/8	4	3235	GRIZZLY 20", IMPORTS	797.95
20 x 1-1/4 x 1/8	3	3238	WOODTEK 20"	597.95
20-3/16 x 1-3/16 x 1/8	3	3241	DELTA DC-580	605.95
20-3/16 x 1-3/8 x 1/8	4	3244	DELTA RC-51 22-460	870.95
20-1/4 x 1-1/4 x 5/32	3	3247	POWERMATIC 221	589.95
20.47 (520 MM) x 30MM x 3MM	4	3250	SCMI 520-550-552	677.95
20-1/2 x 11/16 x 1/8	4	3253	RBI 820	675.95
22-1/8 x 7/8 x 1/8	4	3256	POWERMATIC 201	727.95
24 x 1 x 1/8	3	3259	NORTHWOOD	610.95
24 x 1-1/8 x 1/8	3	3262	CRESCENT	717.95
24 x 1-1/8 x 1/8	4	3265	BRIDGEWOOD, NORTHFIELD	957.95
24 x 1-3/16 x 1/8	3	3268	GRIZZLY 24"	717.95
24 x 1-1/4 x 1/8	3	3271	SECO	717.95
24 x 1-1/4 x 1/8	4	3274	NORTHFIELD	957.95
24 x 1-3/8 x 1/8	4	3277	BUSS 4L 248, OLIVER	999.95
24 x 1-1/8 x 5/32	3	3280	FAY & EGAN, YATES B-44	705.95
24 x 1-1/4 x 5/32	4	3283	POWERMATIC, NORTHFIELD	705.95
24 x 1-3/8 x 5/32	3	3286	FAY & EGAN	782.95
24-1/4 x 1-1/8 x 1/8	3	3289	DELTA 22-470	725.95
24-1/4 x 1-1/8 x 1/8	4	3292	CRESCENT	967.95
24-1/4 x 1-1/4 x 1/8	4	3295	NORTHFIELD	967.95
24-1/4 x 1-1/4 x 5/32	4	3298	POWERMATIC 225, NEWMAN 600	967.95
24-5/16 x 1-1/8 x 1/8	4	3301	WHITNEY P-4	967.95
24-5/16 x 1-1/4 x 1/8	4	3303	WHITNEY 105	967.95
24-1/2 x 1-1/8 x 1/8	3	3306	OLIVER 199-299D	732.95
24-1/2 x 1-1/4 x 5/32	4	3309	OLIVER 199E	977.95
24-13/16 x 1-3/8 x 1/8	4	3312	DELTA RC-63 22-610	1033.95
25 x 11/16 x 1/8	3	3315	WOODMASTER 725	617.95
25 x 1-1/4 x 5/32	4	3318	NORTHFIELD	995.95
25.2 (640 MM) x 35MM x 3MM	4	3321	SCMI F535-630	805.95
30 x 1-1/4 x 1/8	4	3324	YATES B-8	1196.95
30 x 1-3/8 x 1/8	4	3327	BUSS	1246.95
30 x 1-3/8 x 5/32	4	3330	BUSS	1246.95
30-5/16 x 1-3/8 x 1/8	3	3333	WHITNEY	987.95
36 x 1-1/8 x 1/8	1 EA.	3336		344.00
36 x 1-1/4 x 1/8	1 EA.	3339		344.00
36 x 1-3/8 x 1/8	1 EA.	3342		375.00
36-1/4 x 1-1/8 x 1/8	1 EA.	3345		348.00
36-1/4 x 1-1/4 x 1/8	1 EA.	3348		348.00
36-1/4 x 1-3/8 x 1/8	1 EA.	3351		378.00
36-1/2 x 1-1/8 x 1/8	1 EA.	3354		349.00
36-1/2 x 1-1/4 x 1/8	1 EA.	3357		349.00
36-1/2 x 1-3/8 x 1/8	1 EA.	3360		380.00
36 x 1-1/4 x 5/32	1 EA.	3363		344.00
36 x 1-3/8 x 5/32	1 EA.	3366		375.00
36-1/4 x 1-1/4 x 5/32	1 EA.	3369		362.00
36-1/4 x 1-3/8 x 5/32	1 EA.	3372		378.00

* FOR MACHINES AND SIZES NOT LISTED - PLEASE CALL

**CALL TOLL FREE 1-800-443-0992 • FAX TOLL FREE 1-888-728-8665
or visit our web site at www.ridgecarbide.com**



FORSTNER BIT SETS



CARBIDE TIPPED FORSTNER SET

ITEM # 660-500 \$289.00



Carbide tipped forstner bits were designed so the rim remains extremely sharp, especially at the leading edge. It is here that the rim stays engaged in the cut so the bit won't drift laterally. This prevents tearout at the beginning of the cut to give a smooth clean cut. The finished hole will show a small center hole at the bottom of the hole.

Item #660-500
14 pc. Carbide Tipped Set
Wood Case Included

SET INCLUDES THE FOLLOWING BITS

Order No.	Diameter	Shank	Overall Length	Price
660-100	1/2	3/8	3-1/2	\$15.00
660-110	5/8	3/8	3-1/2	16.00
660-120	3/4	3/8	3-1/2	17.00
660-130	7/8	3/8	3-1/2	19.00
660-140	1	3/8	3-1/2	22.00
660-150	1-1/8	3/8	3-1/2	25.00
660-160	1-1/4	3/8	3-1/2	26.00
660-165	1-3/8	3/8	3-1/2	28.00
660-180	1-1/2	3/8	3-1/2	29.00
660-190	1-5/8	3/8	3-1/2	31.00
660-200	1-3/4	3/8	3-1/2	34.00
660-210	1-7/8	3/8	3-1/2	37.00
660-220	2	3/8	3-1/2	39.00
660-230	2-1/8	3/8	3-1/2	40.00

TABLE SAW FLUTE CUTTING GROOVERS

FLUTING CUTTERS FOR TABLE SAWS

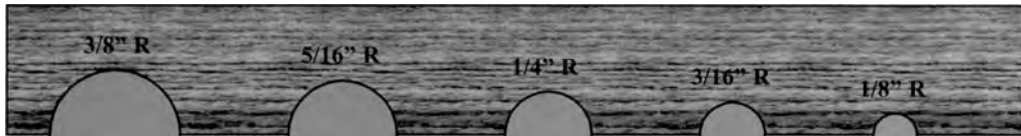

35C	36C	37C	37C-3/8	38C
\$210.00	\$205.00	\$176.00	\$160.00	\$125.00



- Fluting Cutters for table saws are four-wing cutters with 5/8" bores and 6-1/2" diameters.
- For continuous wood pull, the table saw's arbor must be tilted.

CALL TOLL FREE 1-800-443-0992 • FAX TOLL FREE 1-888-728-8665
or visit our web site at www.ridgecarbide.com



BORING BITS



METRIC & INCH SIZE CARBIDE BORING BITS BRAD POINT & THROUGH HOLE V-POINT

TEFLON COATED - AVAILABLE IN LEFT & RIGHT HAND ROTATION
10MM SHANK WITH LOCKING FLAT AND ADJUSTABLE DEPTH SCREW

RIGHT HAND IS COATED IN BLACK - LEFT HAND IS COATED IN ORANGE.
OTHER SIZES AVAILABLE - QUOTATION ON REQUEST

BRAD POINT

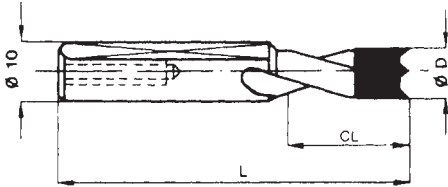

Other Sizes Available - Quotation On Request

Right Hand Order No.	Left Hand Order No.	Cutting Diameter	Overall Length	Price
Brad Point 57 OAL				
SE5704RH	SE5704LH	4mm	57mm	\$11.75
SE57045RH	SE57045LH	4.5mm	57mm	12.25
SE57187RH	SE57187LH	4.76mm (3/16)	57mm	12.25
SE5705RH	SE5705LH	5mm	57mm	11.25
SE57051RH	SE57051LH	5.1mm	57mm	11.50
SE57055RH	SE57055LH	5.5mm	57mm	12.50
SE5706RH	SE5706LH	6mm	57mm	11.50
SE57250RH	SE57250LH	6.35mm (1/4)	57mm	11.75
SE57065RH	SE57065LH	6.5mm	57mm	14.50
SE5707RH	SE5707LH	7mm	57mm	13.50
SE5708RH	SE5708LH	8mm	57mm	13.25
SE57082RH	SE57082LH	8.2mm	57mm	14.50
SE57085RH	SE57085LH	8.5mm	57mm	16.75
SE5709RH	SE5709LH	9mm	57mm	15.50
SE57375RH	SE57375LH	9.52mm (3/8)	57mm	16.25
SE5710RH	SE5710LH	10mm	57mm	15.25
SE5711RH	SE5711LH	11mm	57mm	19.25
SE5712RH	SE5712LH	12mm	57mm	17.25
SE57500RH	SE57500LH	12.7mm (1/2)	57mm	23.75
SE5713RH	SE5713LH	13mm	57mm	22.75
SE5714RH	SE5714LH	14mm	57mm	25.25
SE5715RH	SE5715LH	15mm	57mm	27.50
SE57625RH	SE57625LH	15.9mm (5/8)	57mm	29.60
SE5716RH	SE5716LH	16mm	57mm	29.60
SE5717RH	SE5717LH	17mm	57mm	34.00
SE5718RH	SE5718LH	18mm	57mm	34.00
SE5719RH	SE5719LH	19mm	57mm	40.00
SE5720RH	SE5720LH	20mm	57mm	40.00

Other Sizes Available - Quotation On Request

Right Hand Order No.	Left Hand Order No.	Cutting Diameter	Overall Length	Price
Brad Point 70 OAL				
SE7004RH	SE7004LH	4mm	70mm	\$12.75
SE70045RH	SE70045LH	4.5mm	70mm	13.25
SE70187RH	SE70187LH	4.76mm (3/16)	70mm	13.25
SE7005RH	SE7005LH	5mm	70mm	12.25
SE70051RH	SE70051LH	5.1mm	70mm	12.50
SE70055RH	SE70055LH	5.5mm (7/32)	70mm	13.50
SE7006RH	SE7006LH	6mm	70mm	12.50
SE70250RH	SE70250LH	6.35mm (1/4)	70mm	12.75
SE70065RH	SE70065LH	6.5mm	70mm	15.25
SE7007RH	SE7007LH	7mm	70mm	14.50
SE7008RH	SE7008LH	8mm	70mm	14.25
SE70082RH	SE70082LH	8.2mm	70mm	15.25
SE70085RH	SE70085LH	8.5mm	70mm	17.25
SE7009RH	SE7009LH	9mm	70mm	16.50
SE70375RH	SE70375LH	9.52mm (3/8)	70mm	17.25
SE7010RH	SE7010LH	10mm	70mm	16.25
SE7011RH	SE7011LH	11mm	70mm	20.25
SE7012RH	SE7012LH	12mm	70mm	18.00
SE70500RH	SE70500LH	12.7mm (1/2)	70mm	24.75
SE7013RH	SE7013LH	13mm	70mm	23.75
SE7014RH	SE7014LH	14mm	70mm	26.25
SE7015RH	SE7015LH	15mm	70mm	28.25
SE70625RH	SE70625LH	15.9mm (5/8)	70mm	30.50
SE7016RH	SE7016LH	16mm	70mm	30.50
SE7017RH	SE7017LH	17mm	70mm	35.50
SE7018RH	SE7018LH	18mm	70mm	35.50
SE7019RH	SE7019LH	19mm	70mm	40.50
SE7020RH	SE7020LH	20mm	70mm	40.80
Brad Point 77 OAL				
SE7705RH	SE7705LH	5mm	77mm	\$15.40
SE7706RH	SE7706LH	6mm	77mm	15.60
SE7707RH	SE7707LH	7mm	77mm	18.00
SE7708RH	SE7708LH	8mm	77mm	17.60
SE7710RH	SE7710LH	10mm	77mm	20.00
SE7712RH	SE7712LH	12mm	77mm	22.25

CALL TOLL FREE 1-800-443-0992 • FAX TOLL FREE 1-888-728-8665
or visit our web site at www.ridgecarbide.com

AWARD WINNING - SAW BLADES, ROUTER BITS & SHARPENING SERVICE

ARE YOU FRUSTRATED WITH YOUR LOCAL SHARPENING SERVICE?

If you are looking for a high quality saw & tool sharpening service company send your dull blades; bits, cutters and knives to the experts at Ridge Carbide Tool.



The RCT Tool Doctors will quality sharpen your tired tools back to good health and make them feel and cut better.

Ridge Carbide is a full service saw blade repair & sharpening center. We will return your dull, damaged, warped or wobbly saw blades back to you like new. And sometimes better than new!

Free Return Shipping. See Page 76 For Details.

LISTEN TO WHAT OUR CUSTOMERS THINK.

"The last one you did for us looks beautiful. The finish is magnificent. I hope to send you a lot of business through our customer referral of your company."
James L. Box
CMT Tools, Tampa, FL

"After using your blade, I can't go back to an ordinary blade while waiting for my Ridge Carbide blade to be sharpened."
Robin Scherter,
Statington, PA

"You did a fine job on the first blade I sent you. It now cuts better than it ever did - including new."
Len Feldberg
Chestnut Ridge, NY

"Your grinding is very good and I'm telling students (et. al.) that not only is your grinding the best I know of but it is also the best value."
Patrick Warner
Designer/Furniture Maker
Escondido, CA

SAW BLADE SHARPENING

Up to 13" Diameter

Teeth	Price
up to 12 Teeth	15.00
13 to 24 Teeth	18.00
25 to 40 Teeth	20.00
41 to 60 Teeth	22.00
61 to 80 Teeth	25.00
81 to 100 Teeth	27.00

Try Us!

Additional Charges

• Blades 14" to 16" Dia.	3.50
• Blades 17" to 20" Dia.	7.00
• Replace Missing Saw Tip	5.00 ea.
Add to above sharpening price	

"I was very pleasantly surprised. The blades had never been so sharp. They were not even as sharp when I purchased them new.

From now on, if and when I need saw blades, router bits and/or planer blades sharpened, they will be sent to your company. Your work is top rate and your prices very reasonable."
Kent Pauley
Kent's Hardwood Furniture
Archer, FL

ROUTER BIT SHARPENING

Up to 1-1/4" Cutting Diameter

Description	Price
1 Flute Carbide Plunge	3.50
2 Flute Carbide Plunge	4.50
3 Flute Carbide Plunge	5.00
2 Flute w/Bearing Guide	4.50
3 Flute w/Bearing Guide	5.50
Large Corner Round Bits over 1-1/4" Dia.	10.00
Raised Panel Bits up to 3-1/2" Dia.	15.50
2 Pc. Stile and Rail Bit Set	25.00
HSS Router Bit	4.00
Repoint New End on Router Bit	5.00

Spiral Bits Sharpened Call For Price

1200 QUAD
GRIT
DIAMOND
WHEEL USED

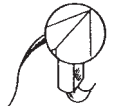

FOR RAZOR
SHARP EDGES

DADO SET SHARPENING

6 Pc. Stack Set - 2 Blades & 4 Two-Tip Chippers

Description	Price
Wobble Dado Blade	20.00
6 to 12 Tooth Blade Sets	35.95
13 to 24 Tooth Blade Sets	45.95
25 to 36 Tooth Blade Sets	48.95
Dado Master (w/Multi-Tooth Chippers)	59.95
Dado Tip Replacements	7.00 ea.

GUARANTEED FLAT BOTTOM CUTS

**We Can
Sharpen
Any Brand
Blade
Or Bit**

SHAPER CUTTER SHARPENING

Carbide Tip	Price
3 Wing up to 1-1/4" Wide	15.00
3 Wing Raised Panel	25.00
High Speed Steel	
3 Wing up to 1-1/4" Wide	12.00
3 Wing Raised Panel	20.00
Planer & Jointer Knives	
Solid Carbide or Carbide Tipped	2.50 per in./per knife
High Speed Steel	.75 per in./per knife

**VISIT OUR
FACTORY OUTLET!**

**OUTLET HOURS:
9-5 P.M. MONDAY THRU FRIDAY**

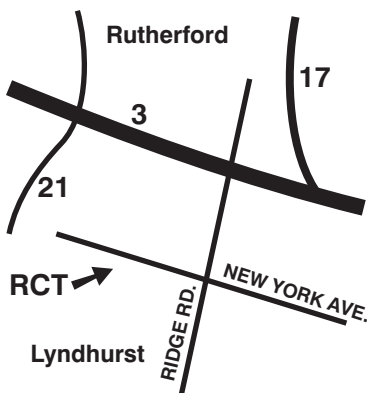

RIDGE CARBIDE TOOL CORP.
P.O. BOX 497
595 NEW YORK AVENUE
LYNDHURST, NJ 07071