

PTFR

Condenser Bushings 24 to 36 kV

OIL-TO-AIR - Resin Impregnated Paper
High current - IEC Standards



PTFR are capacitance graded bushings with resin impregnated paper insulation. They are designed for use on power transformers, installed in any position, in compliance with the latest edition of IEC 60137. Design, components and manufacturing technology guarantee an average life time longer than 30 years under normal operating conditions.

Manufacturing of capacitance graded bushings

The main electrical component is the condenser body that is manufactured using resin-impregnated paper technology. This technology utilizes a continuous sheet of pure crepe paper, wound around a support tube. During the winding process, the first step is to reduce its water content to 1% maximum by drying the paper with heated cylinders and infrared rays. During winding, a series of aluminum foils are coaxially inserted between the layers of the paper in order to grade the best possible distribution of radial and longitudinal electrical gradients between the central conductor and the grounded



flanges. The winding and foil placement is made by computer-controlled machines. After winding, each condenser core is placed into an autoclave for resin impregnation under vacuum. Each core is then machined to achieve the final shape.

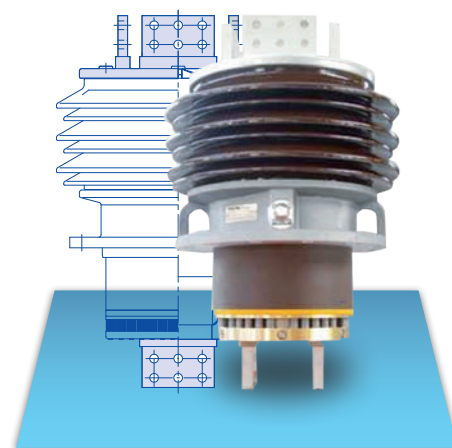

Customer Benefits

- Bushings with longer lifetime and higher reliability
- Possibility to use bushings under extreme weather condition
- No performance reduction with age
- PD free

The bushing is designated as follows:
PTFR.24.125.12000

PTFR	Condenser bushings, transformer (for use on), high current, Resin impregnated Paper (RIP) technology
24	Rated voltage in kV
125	BIL (Basic Insulation Level) in kV
12000	Rated current in A

Main features

PTFR: Resin Impregnated Paper High current IEC Standards

- Rated voltages 24 and 36 kV
- Air side : porcelain insulator
- Oil side: resin impregnated paper winding
- Inner conductor made of cast aluminum
- Dry filling of the interspace between porcelain and condenser body
- Installation in any position
- Flange of aluminum alloy casting
- Maximum current rating up to 24.000 A
- Flange provided with power factor tap and Buchholz relay connection

Fig. 1: Section

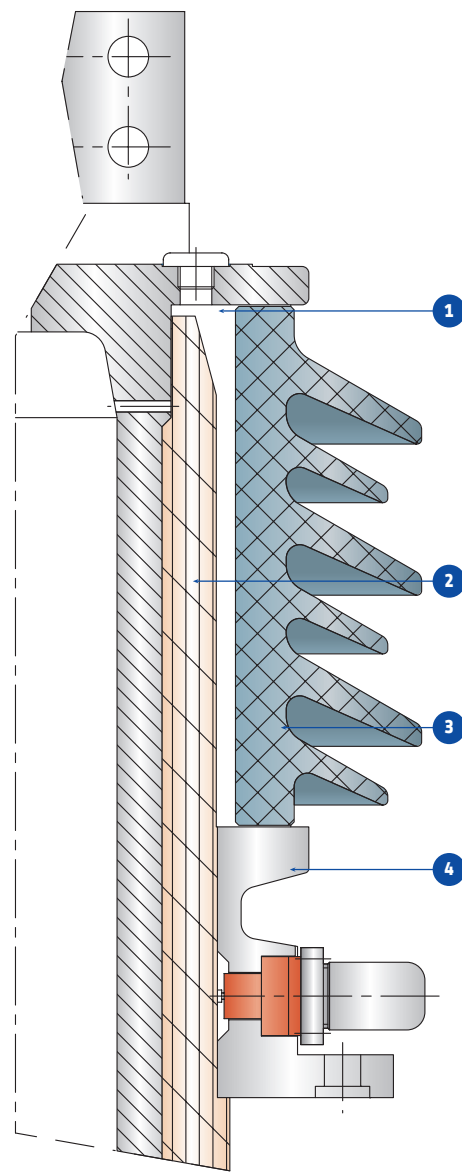

1. Dry filling
2. Condenser body
3. Porcelain insulator
4. Flange

Air side

The air side envelope is made of brown colored porcelain. The creepage distance is for a very high polluted atmosphere (VHP) equivalent to 31 mm/kV. The shed configuration is alternate-type (small-large sheds). This is the most effective solution, proven by salt tests and the profile of sheds complies with the recommendations of IEC 60815. The air extremity of the bushing inner conductor is provided by two or more palms for the connections of the bus bars, which are normally enclosed in a metal clad duct.

Oil side

The condenser body is immersed in the transformer oil and is hermetically sealed to the flange. The springs, located on the oil side, are used for mechanical coupling of all bushings parts and to avoid shifting due to the thermal variations. The oil extremity of the inner conductor is provided with one or more palms for the connection to the transformer windings.

Current ratings

The acceptable operating currents versus oil temperatures and bus-duct air compared to conductor can be calculated using the following formula:

$$I_{na} = I_n \times \alpha \times \beta$$

where:

I_{na} continuous admissible current [A]

I_n nominal bushing current [A]

α temperature coefficient

β CT space coefficient

α and β can be determined using the tables here below, where:

T_c admissible conductor temperature (120°C)

T_a ambient (bus duct) air temperature (°C)

T_o transformer oil temperature (°C)

K CT space (mm)

$T_c - T_a$ (°C)	Coefficient α (24 kV TYPE)				
90	0.83	0.91	1.01	1.09	1.16
80	0.80	0.87	0.97	1.05	1.13
70	0.74	0.83	0.93	1.02	1.11
60	0.69	0.80	0.90	1.00	1.10
50	0.65	0.77	0.87	0.98	1.09
40	0.61	0.73	0.84	0.96	1.08
30	0.57	0.70	0.82	0.94	1.07
20	0.53	0.66	0.79	0.92	1.06
10	0.50	0.63	0.76	0.90	1.05
$T_c - T_o$ (°C)	10	20	30	40	50

$T_c - T_a$ (°C)	Coefficient α (36 kV TYPE)				
90	0.76	0.83	0.92	0.99	1.06
80	0.72	0.79	0.88	0.96	1.03
70	0.67	0.76	0.85	0.93	1.01
60	0.63	0.73	0.82	0.91	1.00
50	0.59	0.70	0.79	0.89	0.99
40	0.55	0.66	0.76	0.86	0.96
30	0.50	0.63	0.73	0.84	0.95
20	0.46	0.59	0.70	0.81	0.93
10	0.43	0.56	0.67	0.79	0.91
$T_c - T_o$ (°C)	10	20	30	40	50

K (mm)	Coefficient β			
	24 kV TYPE		36 kV TYPE	
	$T_a = 40^\circ\text{C}$	$T_a = 80^\circ\text{C}$	$T_a = 40^\circ\text{C}$	$T_a = 80^\circ\text{C}$
0	1.00	1.00	1.00	1.00
100	0.94	0.99	0.97	0.99
200	0.87	0.97	0.90	0.95
300	0.81	0.95	0.84	0.91
400	0.75	0.91	0.79	0.87
500	0.68	0.87	0.75	0.83
600	0.61	0.81	-	-
700	0.55	0.75	-	-

Conductor and terminals

Both sides of the conductor and terminals are made from a unique cast aluminum alloy, which has an IACS 55% conductivity. Terminal surfaces are not treated. Upon request it is possible to provide them with 10 micron silver plating.

Flange

The flange is made from cast aluminum, and is equipped with lifting holes, a power factor tap (tested at 3 kV for 60 s) (fig. 2) and Buchholz relay connection (1/2" gas outlet plug) (fig. 6).

Fig. 2: Power Factor Tap

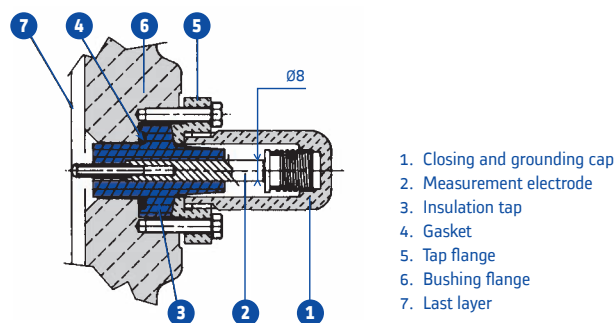

Assembling

The coupling between porcelains and metal parts (flange and inner conductor) is achieved with belleville washer-type springs, placed in the oil side of the bushings.

Gaskets

Made of Viton® a fluorocarbon rubber elastomer (FPM), o-ring type. They are compatible with all the fluids they are in contact with (transformer mineral oil). Air side gaskets are carefully protected, by means of a sealing, against influence of polluting weather elements. For special requirements, such as low ambient temperatures (down to -55°C), special o-rings are used.

Fig. 3: PTFR dimensions

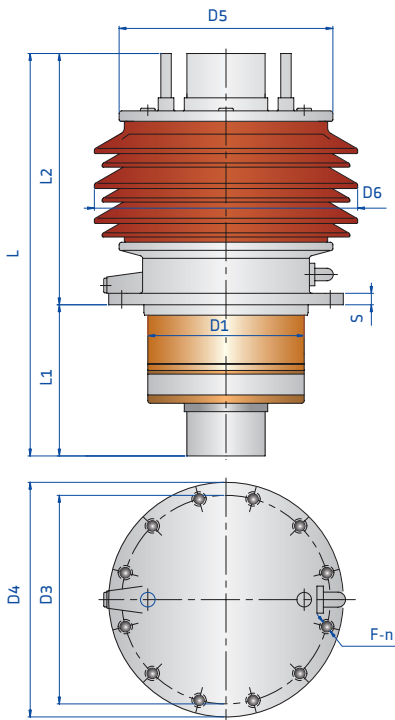

Dry filling

PTFR bushings can be installed in any position because the interspace between porcelain and condenser body is filled with a dry mass (polyol-isocyanate).

This material offers:

- Low dielectric losses
- Good level of partial discharges
- Good thermal resistance
- Constant characteristics versus time

Dry filling improves reliability in comparison with oil filled type and makes installation simpler: no oil leakage and, if horizontal installation, no oil reservoir.

Tests

All bushings have electrical characteristics that are tested in compliance with the last edition of CEI IEC 60137-Publication insulated bushings for alternating voltages above 1000 V, and Main National Standards.

Nameplate

Each bushing is provided with a name plate, (fig. 4) with all the electrical data and serial number, in accordance with the prescription of IEC Standards. The stainless steel plate is placed on the flange by rivets.

Fig. 4: Nameplate

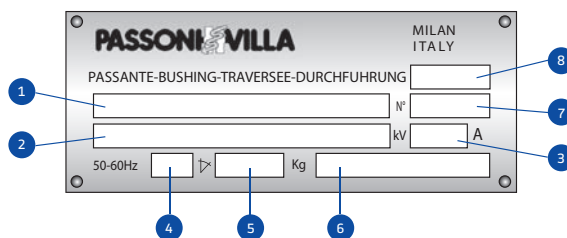

1. Bushing type
2. Insulating voltage
3. Rated current
4. Max. mounting angle off of the vertical
5. Weight
6. Blank (available)
7. Serial number
8. Month - year of final tests

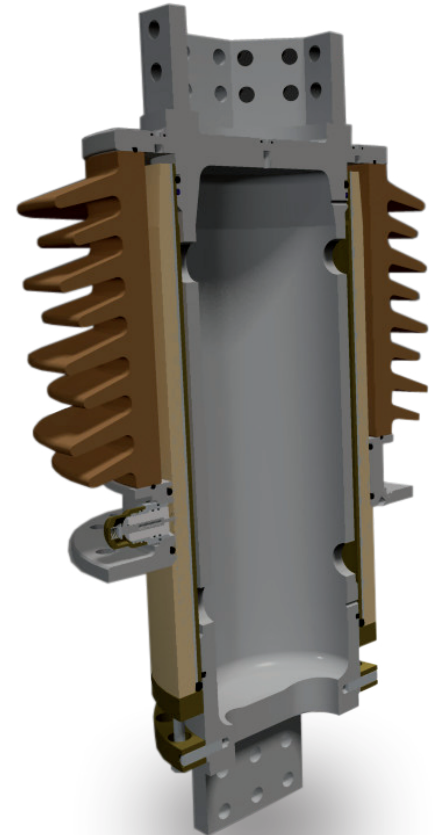

Dimensions		Rated Voltage	Rated phase to earth voltage	Dry and wet power frequency withstand voltage (60°)	Dry lightning impulse withstand voltage	Rated current	Free insulation length in air	Min. nominal creepage distance	Pair of sheds (small + large)	Carrier load	Weight	Max. operating altitude
Item		1	2	3	4	5	6	7	8	9	10	11
Type		kV	kV	kV	kV	A	mm	mm	n°	N	kg	m
1	24.125.7500	24	14	50	125	7500	230	828	3	3150	60	1000
2	24.125.9000	24	14	50	125	9000	230	828	3	3150	60	1000
3	24.125.12000	24	14	50	125	12000	230	828	3	3150	60	1000
4	24.125.15000	24	14	50	125	15000	230	828	3	3150	60	1000
5	24.125.19000	24	14	50	125	19000	230	828	3	3150	60	1000
6	24.125.24000	24	14	50	125	24000	230	1205	4,5	3150	210	3000
7	36.170.7500	36	21	70	170	7500	460	1650	6	3150	80	3000
8	36.170.9000	36	21	70	170	9000	460	1650	6	3150	100	3000
9	36.170.12000	36	21	70	170	12000	460	1650	6	3150	110	1000
10	36.170.15000	36	21	70	170	15000	320	1205	4,5	3150	145	1000
11	36.170.19000	36	21	70	170	19000	460	1650	6	3150	230	3000
12	36.170.24000	36	21	70	170	24000	320	1205	4,5	3150	220	1000

Dimensions		L	L1	L2	D1	D3	D4	D5	D6	NR	F	S	Top palm	Bottom palm
Item		12	13	14	15	17	18	19	20	21	22	23	24	25
Type		mm	mm	mm	mm	mm	mm	mm	mm	N°	mm	mm	Fig.	Fig.
1	24.125.7500	770	290	480	190	290	335	260	360	12	16	19	7	8
2	24.125.9000	770	290	480	218	290	335	345	445	12	16	19	9	10
3	24.125.12000	770	290	480	255	350	400	345	445	12	20	21	11	12
4	24.125.15000	770	290	480	300	400	450	410	505	12	20	22	13	14
5	24.125.19000	770	290	480	360	450	500	460	555	12	20	22	15	16
6	24.125.24000	860	290	570	435	535	590	530	625	16	22	23	17	18
7	36.170.7500	1030	320	710	190	290	335	260	360	12	16	19	7	8
8	36.170.9000	1030	320	710	218	290	335	345	445	12	16	19	9	10
9	36.170.12000	1030	320	710	255	350	400	345	445	12	20	21	11	12
10	36.170.15000	890	320	570	300	400	450	410	505	12	20	22	13	14
11	36.170.19000	1030	320	710	360	450	500	460	555	12	20	22	15	16
12	36.170.24000	890	320	570	435	535	590	530	625	16	22	23	17	18

Fig. 5: Flange fixing holes

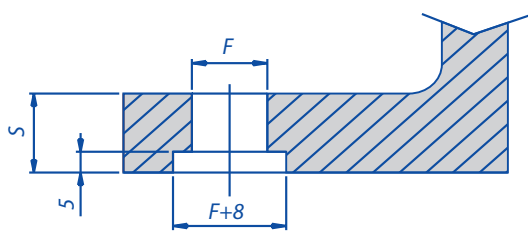
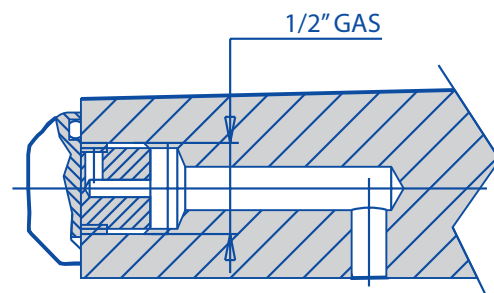

Fig. 6: Buchholz relay connection



Top palms

7500 A



Fig. 7

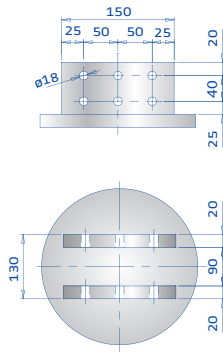

9000 A



Fig. 9

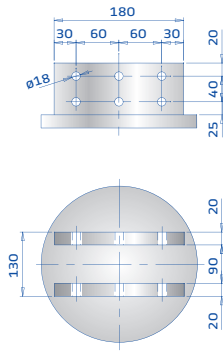

12000 A



Fig. 11

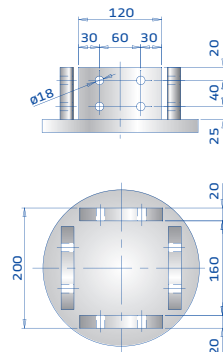

Bottom palms

Fig. 8

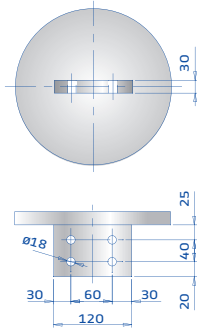

Fig. 10

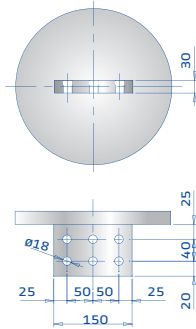
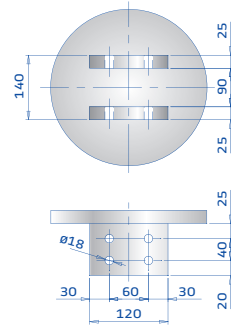

Fig. 12



Top palms

15000 A



Fig. 13

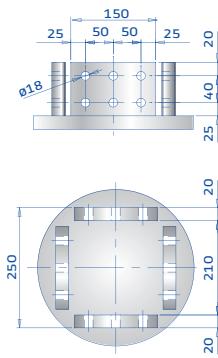

19000 A



Fig. 15

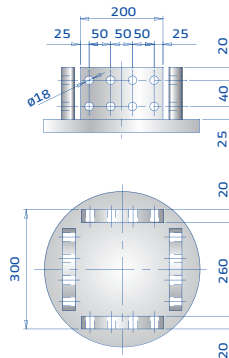

24000 A



Fig. 17

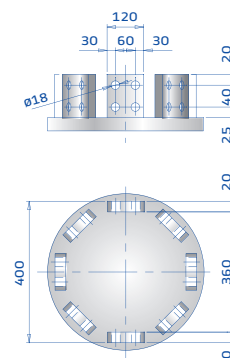

Bottom palms

Fig. 14

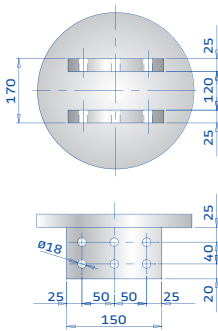

Fig. 16

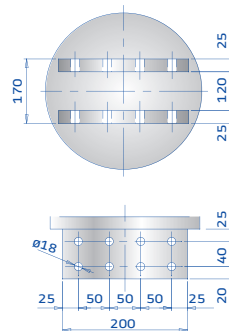
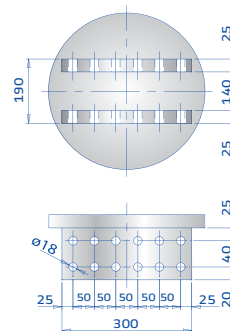

Fig. 18



PASSONI & VILLA
AN ALSTOM COMPANY

Following the acquisition of PASSONI & VILLA, Alstom Grid now offers a large portfolio of condenser bushings for AC or DC operation. If you require any further information, please address your queries to

rpv@alstom.com

Alstom Grid Worldwide Contact Centre
www.grid.alstom.com/contactcentre
Tel.: +44 (0) 1785 250 070
www.grid.alstom.com

To contact the manufacturer
Viale Suzzani, 229 20162 MILANO (Italy)
Tel: +39 02 661 221
Fax: +39 02 647 09 06
Email: rpv@alstom.com

GRID

ALSTOM