

Miller AV Series Heavy Duty Air Cylinders

Catalog M0910-4

March, 2011



**Up to 250 PSI Air Service
Bore Sizes 1" through 14"
17 Mounting Styles**



MHP Series Cylinders
210 BAR



MHP Series cylinders are designed to meet the requirements of ISO 6020/2 (1991), 160 BAR Compact Series. MHP Series cylinders may be used for working pressures up to 210 BAR. Bore sizes from 25mm to 200mm.

VE Series Cylinders
Up to 150 PSI



VE Series Cylinders for Valve Actuation feature a removable rod bushing for easy rod seal service. Optional welded or threaded lift eye. Bore sizes from 2" to 24".

JV Series Cylinders
400-2300 PSI



Our popularly-priced line of medium pressure hydraulic cylinders, with bore sizes from 1" to 8".

HV2 Series Cylinders
3000 PSI



Miller's heavy-duty cylinder line for demanding hydraulic applications. Bore sizes from 1-1/2" to 8".

In line with our policy of continuing product improvement, specifications and information contained in this catalog are subject to change.

Copyright ©2011 by Parker Hannifin Corporation. All rights reserved.

PRINTED IN THE U.S.A.

⚠ WARNING

FAILURE OR IMPROPER SELECTION OR IMPROPER USE OF THE PRODUCTS AND/OR SYSTEMS DESCRIBED HEREIN OR RELATED ITEMS CAN CAUSE DEATH, PERSONAL INJURY AND PROPERTY DAMAGE.

This document and other information from the Parker Hannifin Corporation, its subsidiaries and authorized distributors provide product and/or system options for further investigation by users having expertise. It is important that you analyze all aspects of your application, including consequences of any failure and review the information concerning the product or system in the current product catalog. Due to the variety of operating conditions and applications for these products or systems, the user, through its own analysis and testing, is solely responsible for making the final selection of the products and systems and assuring that all performance, safety and warning requirements of the application are met.

The products described herein, including without limitation, product features, specifications, designs, availability and pricing, are subject to change by Parker Hannifin Corporation and its subsidiaries at any time without notice.

Offer of Sale

The items described in this document are hereby offered for sale by Parker Hannifin Corporation, its subsidiaries or its authorized distributors. This offer and its acceptance are governed by provisions stated on a separate page of the document entitled 'Offer of Sale'.

Miller AV Series Heavy-Duty Air Cylinders

| Table of Contents | Page |
|---|-------------|
| Specifications, Mounting Styles, Ordering Notes | 3 |
| Cylinder Features..... | 4, 5 |
| Dimensions 1" to 6" Bore Sizes | |
| Model 72, Side Lug Mount (NFPA MS2)..... | 6, 7 |
| Model 74, Side Tap Mount (NFPA MS4) | 8, 9 |
| Model 61, Head Rectangular Flange Mount (NFPA MF1) | 10, 11 |
| Model 62, Cap Rectangular Flange Mount (NFPA MF2)..... | 12, 13 |
| Model 65, Head Square Flange Mount (NFPA MF5)..... | 14, 15 |
| Model 66, Cap Square Flange Mount (NFPA MF6)..... | 14, 15 |
| Model 51, Tie Rods Extended Mountings | |
| (Both Ends NFPA MX1, Cap End NFPA MX2, Head End NFPA MX3) | 16, 17 |
| Model 81, Head Trunnion Mount (NFPA MT1) | 18, 19 |
| Model 82, Cap Trunnion Mount (NFPA MT2)..... | 20, 21 |
| Model 89, Intermediate Trunnion Mount (NFPA MT4)..... | 22, 23 |
| Model 84, Cap Fixed Clevis Mount (NFPA MP1) | 24, 25 |
| Double Rod End Cylinders..... | 26, 27 |
| Dimensions 7" to 14" Bore Sizes | |
| Model 72, Side Lug Mount (NFPA MS2)..... | 28, 29 |
| Model 74, Side Tap Mount (NFPA MS4) | 28, 29 |
| Model 63, Head Square Mount (NFPA ME3)..... | 30, 31 |
| Model 64, Cap Square Mount (NFPA ME4)..... | 30, 31 |
| Models 81, 82, and 89 Trunnion Mountings | |
| (Head Trunnion NFPA MT1, Cap Trunnion NFPA MT2, Intermediate Trunnion NFPA MT4) | 32, 33 |
| Model 84, Cap Fixed Clevis Mount (NFPA MP1) | 34, 35 |
| Model 53 Series, Tie Rods Extended Mountings | |
| (Both Ends NFPA MX1, Cap End NFPA MX2, Head End NFPA MX3) | 34, 35 |
| Double Rod End Cylinders..... | 36, 37 |
| Spherical Bearing Mounting | 38 - 41 |
| Spherical Bearing Mounting Accessories..... | 42 |
| AVN Non-Lube Cylinder..... | 43 - 45 |
| Cylinder Accessories | 46 - 49 |
| “Style 9” Piston Rod End – Split Flange Coupling Rod End | 50 |
| “Style 9” Piston Rod End – Split Couplers and Weld Plates | 51 |
| Linear Alignment Couplers | 52 |
| Push and Pull Forces..... | 53 |
| Operating Fluids and Temperature Range | 54 |
| Ports..... | 56 |
| Stroke Tolerance and Cylinder Weights | 57 |
| Stop Tubing, Mounting Classes | 58 |
| Piston Rod Selection Chart and Data..... | 59 |
| Deceleration Force and Air Requirements | 60 |
| Air Requirements | 61 - 63 |
| Mounting, Parts Identification | 65, 66 |
| Parts Identification, Cushion Kits..... | 67 |
| Parts Identification, Seal Kits, Standard Seals..... | 68 |
| Parts Identification, Seal Kits, Group 5 Service | 69 |
| AVN Series, Seal Kits, Parts Identification | 70 |
| How to Select a Miller Cylinder..... | 72 |
| How to Order..... | 73 |
| Cylinder Safety Guide | 74-75 |
| Offer of Sale..... | 76 |

Miller Fluid Power AV Series Heavy-Duty Air Cylinder



When the job calls for reliable, heavy-duty performance, specify AV Series. A 100,000 psi yield strength chrome-plated, case-hardened piston rod. A 125,000 psi yield strength rod-end stud with rolled threads. 100,000 psi yield strength tie rods. With this construction, Miller Fluid Power AV Series is rated for air service to 250 psi.

They're truly premium quality cylinders, factory prelubricated for millions of maintenance-free cycles...with or without added lubrication. And to make sure every cylinder is premium quality, we subject each and every one – not just batch samples – to tough inspection and performance tests. See inside for the inside story on all the features that make AV Series the high performance, long lasting choice for all your heavy-duty air applications.

Note: Rod diameters over 2¹/₂" will use a threaded bushing.

Miller AV Series Heavy-Duty Air Cylinders

Specifications
Mounting Styles
Ordering Notes

Standard Specifications

- Heavy Duty Service – ANSI/(NFPA) T3.6.7R2-1996 Specifications and Mounting Dimension Standards
- Standard Construction – Square Head – Tie Rod Design
- Nominal Pressure – Up to 250 PSI Air Service
- Standard Fluid – Filtered Air
- Standard Temperature – -10°F. to +165°F.*
- Bore Sizes – 1" through 14"
- Piston Rod Diameter – 1/2" through 5 1/2"
- Mounting Styles – 14 standard styles
- Strokes – Available in any practical stroke length
- Cushions – Optional at either end or both ends of stroke. "Float Check" at cap end. Cushions not available on 1" bore.
- Rod Ends – Three Standard Choices – Specials to Order

*See Engineering Section for higher temperature service.

In line with our policy of continuing product improvement, specifications in this catalog are subject to change.

Mounting Styles and Ordering Notes

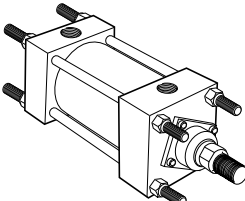
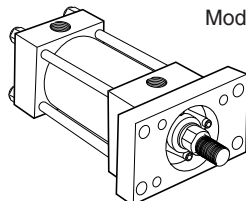
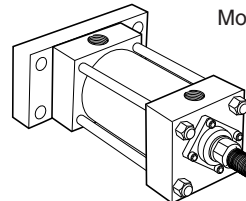
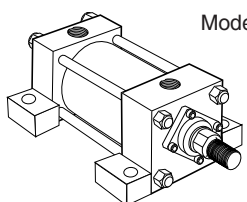
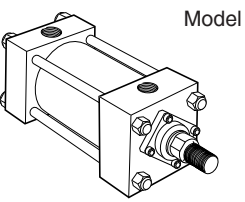
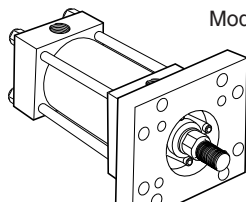
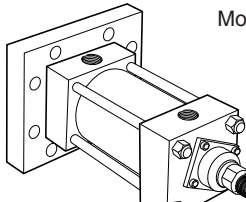
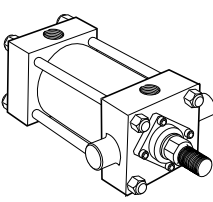
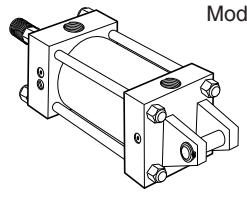
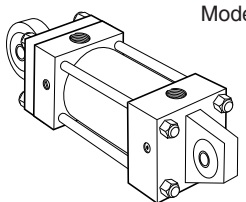
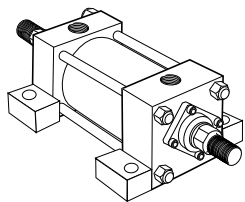
| Available in all bore and rod combinations. | | Available in all bore and rod combinations through 6" bore. 8"-14" bores supplied as Head Square (Model 63) and Cap Square (Model 64) mounts. | | | | | | | | | | | | | | | | | | | | | | | | | | | | | | | | | | | | | | | | | | | | | | | | | | | | | | | | | | | | | | | | | | | | | | | | | | | | | | | | | | | | | | | | | | | | | | | | | | | | | | | | | | | | | | | | | | | | | | | | | | | | | | | | | | | | | | | | | |
|--|--|---|----------------------|---|----------|----------|------|----------|----------------------|----------------------|----------------------|----------|----------|---|----------|--|---|--|---|-----|-------|----------|--|---|--|---|-----|---|----------|--|---|---|---|-----|--|-------|--|---|---|---|-----|-------|----------|--|---|---|---|-----|--|-------|--|---|---|---|-----|--|-------|--|---|---|---|-----|-------|---------------|--|---|---|---|-----|---|----------------------|--|---|---|---|-----|--|-------|--|---|---|---|-----|---|-------------------|--|---|---|---|-----|--|-------|--|---|---|---|-----|---|------------------------|--|---|---|---|-----|---|-----------------|--|---|--|-----|---|----|---------------------------|--|---|--|-----|---|-----|---------------|--|---|--|-----|---|-----|-----------|--|---|--|-----|---|-----|---------------|--|---|--|-----|---|
| <p>Tie Rods Extended Both Ends</p>  <p>Both Ends Model 51 Cap End Model 52 Head End Model 53</p> <p>Both Ends (NFPA MX1) Cap End (NFPA MX2) Head End (NFPA MX3)</p> | | <p>Head Rectangular Flange</p>  <p>Model 61</p> <p>(NFPA MF1)</p> | | <p>Cap Rectangular Flange</p>  <p>Model 62</p> <p>(NFPA MF2)</p> | | | | | | | | | | | | | | | | | | | | | | | | | | | | | | | | | | | | | | | | | | | | | | | | | | | | | | | | | | | | | | | | | | | | | | | | | | | | | | | | | | | | | | | | | | | | | | | | | | | | | | | | | | | | | | | | | | | | | | | | | | | | | | | | | | | | | | | |
| <p>Side Lug</p>  <p>Model 72</p> <p>(NFPA MS2)</p> | <p>Side Tap</p>  <p>Model 74</p> <p>(NFPA MS4)</p> | <p>Head Square Flange</p>  <p>Model 65</p> <p>(NFPA MF5)</p> | | <p>Cap Square Flange</p>  <p>Model 66</p> <p>(NFPA MF6)</p> | | | | | | | | | | | | | | | | | | | | | | | | | | | | | | | | | | | | | | | | | | | | | | | | | | | | | | | | | | | | | | | | | | | | | | | | | | | | | | | | | | | | | | | | | | | | | | | | | | | | | | | | | | | | | | | | | | | | | | | | | | | | | | | | | | | | | | | |
| <p>Trunnion Mounts</p>  <p>Head Model 81 Cap Model 82 Intermediate Model 89</p> <p>Head (NFPA MT1) Cap (NFPA MT2) Intermediate (NFPA MT4)</p> | | <p>Rod Bushing Construction</p> <p>B = Bolted Bushing R = Retainer Held Bushing</p> <table border="1"> <thead> <tr> <th>Bore</th> <th>Rod Dia.</th> <th>51 62 74 84</th> <th>52 66 81 89</th> <th>53 72 82 94</th> <th>61 65</th> <th>63 64</th> </tr> </thead> <tbody> <tr> <td>1</td> <td>1/2, 5/8</td> <td></td> <td>R</td> <td></td> <td>R</td> <td>N/A</td> </tr> <tr> <td>1 1/2</td> <td>5/8 1</td> <td></td> <td>B</td> <td></td> <td>R</td> <td>N/A</td> </tr> <tr> <td>2</td> <td>5/8 1</td> <td></td> <td>B</td> <td>B</td> <td>R</td> <td>N/A</td> </tr> <tr> <td></td> <td>1 3/8</td> <td></td> <td>R</td> <td>R</td> <td>R</td> <td>N/A</td> </tr> <tr> <td>2 1/2</td> <td>5/8 1</td> <td></td> <td>B</td> <td>B</td> <td>B</td> <td>N/A</td> </tr> <tr> <td></td> <td>1 3/8</td> <td></td> <td>R</td> <td>R</td> <td>R</td> <td>N/A</td> </tr> <tr> <td></td> <td>1 3/4</td> <td></td> <td>R</td> <td>R</td> <td>R</td> <td>N/A</td> </tr> <tr> <td>3 1/4</td> <td>1 1 3/8, 2</td> <td></td> <td>B</td> <td>B</td> <td>B</td> <td>N/A</td> </tr> <tr> <td>4</td> <td>1, 1 3/8 1 3/4, 2</td> <td></td> <td>B</td> <td>B</td> <td>B</td> <td>N/A</td> </tr> <tr> <td></td> <td>2 1/2</td> <td></td> <td>B</td> <td>R</td> <td>R</td> <td>N/A</td> </tr> <tr> <td>5</td> <td>1 - 2 2 1/2, 3</td> <td></td> <td>B</td> <td>B</td> <td>R</td> <td>N/A</td> </tr> <tr> <td></td> <td>3 1/2</td> <td></td> <td>R</td> <td>R</td> <td>R</td> <td>N/A</td> </tr> <tr> <td>6</td> <td>1 3/8 - 2 1/2 3 - 4</td> <td></td> <td>B</td> <td>B</td> <td>R</td> <td>N/A</td> </tr> <tr> <td>7</td> <td>1 3/8, 1 3/4, 2</td> <td></td> <td>B</td> <td></td> <td>N/A</td> <td>B</td> </tr> <tr> <td>8*</td> <td>1 3/8 - 4 1/2 5, 5 1/2</td> <td></td> <td>B</td> <td></td> <td>N/A</td> <td>B</td> </tr> <tr> <td>10*</td> <td>1 3/4 - 5 1/2</td> <td></td> <td>B</td> <td></td> <td>N/A</td> <td>B</td> </tr> <tr> <td>12*</td> <td>2 - 5 1/2</td> <td></td> <td>B</td> <td></td> <td>N/A</td> <td>B</td> </tr> <tr> <td>14*</td> <td>2 1/2 - 5 1/2</td> <td></td> <td>B</td> <td></td> <td>N/A</td> <td>B</td> </tr> </tbody> </table> <p>*65, 66, 61, 62 not available in these bore sizes.</p> | | | | | Bore | Rod Dia. | 51 62 74 84 | 52 66 81 89 | 53 72 82 94 | 61 65 | 63 64 | 1 | 1/2, 5/8 | | R | | R | N/A | 1 1/2 | 5/8 1 | | B | | R | N/A | 2 | 5/8 1 | | B | B | R | N/A | | 1 3/8 | | R | R | R | N/A | 2 1/2 | 5/8 1 | | B | B | B | N/A | | 1 3/8 | | R | R | R | N/A | | 1 3/4 | | R | R | R | N/A | 3 1/4 | 1 1 3/8, 2 | | B | B | B | N/A | 4 | 1, 1 3/8 1 3/4, 2 | | B | B | B | N/A | | 2 1/2 | | B | R | R | N/A | 5 | 1 - 2 2 1/2, 3 | | B | B | R | N/A | | 3 1/2 | | R | R | R | N/A | 6 | 1 3/8 - 2 1/2 3 - 4 | | B | B | R | N/A | 7 | 1 3/8, 1 3/4, 2 | | B | | N/A | B | 8* | 1 3/8 - 4 1/2 5, 5 1/2 | | B | | N/A | B | 10* | 1 3/4 - 5 1/2 | | B | | N/A | B | 12* | 2 - 5 1/2 | | B | | N/A | B | 14* | 2 1/2 - 5 1/2 | | B | | N/A | B |
| Bore | Rod Dia. | 51 62 74 84 | 52 66 81 89 | 53 72 82 94 | 61 65 | 63 64 | | | | | | | | | | | | | | | | | | | | | | | | | | | | | | | | | | | | | | | | | | | | | | | | | | | | | | | | | | | | | | | | | | | | | | | | | | | | | | | | | | | | | | | | | | | | | | | | | | | | | | | | | | | | | | | | | | | | | | | | | | | | | | | | | | | | | |
| 1 | 1/2, 5/8 | | R | | R | N/A | | | | | | | | | | | | | | | | | | | | | | | | | | | | | | | | | | | | | | | | | | | | | | | | | | | | | | | | | | | | | | | | | | | | | | | | | | | | | | | | | | | | | | | | | | | | | | | | | | | | | | | | | | | | | | | | | | | | | | | | | | | | | | | | | | | | | |
| 1 1/2 | 5/8 1 | | B | | R | N/A | | | | | | | | | | | | | | | | | | | | | | | | | | | | | | | | | | | | | | | | | | | | | | | | | | | | | | | | | | | | | | | | | | | | | | | | | | | | | | | | | | | | | | | | | | | | | | | | | | | | | | | | | | | | | | | | | | | | | | | | | | | | | | | | | | | | | |
| 2 | 5/8 1 | | B | B | R | N/A | | | | | | | | | | | | | | | | | | | | | | | | | | | | | | | | | | | | | | | | | | | | | | | | | | | | | | | | | | | | | | | | | | | | | | | | | | | | | | | | | | | | | | | | | | | | | | | | | | | | | | | | | | | | | | | | | | | | | | | | | | | | | | | | | | | | | |
| | 1 3/8 | | R | R | R | N/A | | | | | | | | | | | | | | | | | | | | | | | | | | | | | | | | | | | | | | | | | | | | | | | | | | | | | | | | | | | | | | | | | | | | | | | | | | | | | | | | | | | | | | | | | | | | | | | | | | | | | | | | | | | | | | | | | | | | | | | | | | | | | | | | | | | | | |
| 2 1/2 | 5/8 1 | | B | B | B | N/A | | | | | | | | | | | | | | | | | | | | | | | | | | | | | | | | | | | | | | | | | | | | | | | | | | | | | | | | | | | | | | | | | | | | | | | | | | | | | | | | | | | | | | | | | | | | | | | | | | | | | | | | | | | | | | | | | | | | | | | | | | | | | | | | | | | | | |
| | 1 3/8 | | R | R | R | N/A | | | | | | | | | | | | | | | | | | | | | | | | | | | | | | | | | | | | | | | | | | | | | | | | | | | | | | | | | | | | | | | | | | | | | | | | | | | | | | | | | | | | | | | | | | | | | | | | | | | | | | | | | | | | | | | | | | | | | | | | | | | | | | | | | | | | | |
| | 1 3/4 | | R | R | R | N/A | | | | | | | | | | | | | | | | | | | | | | | | | | | | | | | | | | | | | | | | | | | | | | | | | | | | | | | | | | | | | | | | | | | | | | | | | | | | | | | | | | | | | | | | | | | | | | | | | | | | | | | | | | | | | | | | | | | | | | | | | | | | | | | | | | | | | |
| 3 1/4 | 1 1 3/8, 2 | | B | B | B | N/A | | | | | | | | | | | | | | | | | | | | | | | | | | | | | | | | | | | | | | | | | | | | | | | | | | | | | | | | | | | | | | | | | | | | | | | | | | | | | | | | | | | | | | | | | | | | | | | | | | | | | | | | | | | | | | | | | | | | | | | | | | | | | | | | | | | | | |
| 4 | 1, 1 3/8 1 3/4, 2 | | B | B | B | N/A | | | | | | | | | | | | | | | | | | | | | | | | | | | | | | | | | | | | | | | | | | | | | | | | | | | | | | | | | | | | | | | | | | | | | | | | | | | | | | | | | | | | | | | | | | | | | | | | | | | | | | | | | | | | | | | | | | | | | | | | | | | | | | | | | | | | | |
| | 2 1/2 | | B | R | R | N/A | | | | | | | | | | | | | | | | | | | | | | | | | | | | | | | | | | | | | | | | | | | | | | | | | | | | | | | | | | | | | | | | | | | | | | | | | | | | | | | | | | | | | | | | | | | | | | | | | | | | | | | | | | | | | | | | | | | | | | | | | | | | | | | | | | | | | |
| 5 | 1 - 2 2 1/2, 3 | | B | B | R | N/A | | | | | | | | | | | | | | | | | | | | | | | | | | | | | | | | | | | | | | | | | | | | | | | | | | | | | | | | | | | | | | | | | | | | | | | | | | | | | | | | | | | | | | | | | | | | | | | | | | | | | | | | | | | | | | | | | | | | | | | | | | | | | | | | | | | | | |
| | 3 1/2 | | R | R | R | N/A | | | | | | | | | | | | | | | | | | | | | | | | | | | | | | | | | | | | | | | | | | | | | | | | | | | | | | | | | | | | | | | | | | | | | | | | | | | | | | | | | | | | | | | | | | | | | | | | | | | | | | | | | | | | | | | | | | | | | | | | | | | | | | | | | | | | | |
| 6 | 1 3/8 - 2 1/2 3 - 4 | | B | B | R | N/A | | | | | | | | | | | | | | | | | | | | | | | | | | | | | | | | | | | | | | | | | | | | | | | | | | | | | | | | | | | | | | | | | | | | | | | | | | | | | | | | | | | | | | | | | | | | | | | | | | | | | | | | | | | | | | | | | | | | | | | | | | | | | | | | | | | | | |
| 7 | 1 3/8, 1 3/4, 2 | | B | | N/A | B | | | | | | | | | | | | | | | | | | | | | | | | | | | | | | | | | | | | | | | | | | | | | | | | | | | | | | | | | | | | | | | | | | | | | | | | | | | | | | | | | | | | | | | | | | | | | | | | | | | | | | | | | | | | | | | | | | | | | | | | | | | | | | | | | | | | | |
| 8* | 1 3/8 - 4 1/2 5, 5 1/2 | | B | | N/A | B | | | | | | | | | | | | | | | | | | | | | | | | | | | | | | | | | | | | | | | | | | | | | | | | | | | | | | | | | | | | | | | | | | | | | | | | | | | | | | | | | | | | | | | | | | | | | | | | | | | | | | | | | | | | | | | | | | | | | | | | | | | | | | | | | | | | | |
| 10* | 1 3/4 - 5 1/2 | | B | | N/A | B | | | | | | | | | | | | | | | | | | | | | | | | | | | | | | | | | | | | | | | | | | | | | | | | | | | | | | | | | | | | | | | | | | | | | | | | | | | | | | | | | | | | | | | | | | | | | | | | | | | | | | | | | | | | | | | | | | | | | | | | | | | | | | | | | | | | | |
| 12* | 2 - 5 1/2 | | B | | N/A | B | | | | | | | | | | | | | | | | | | | | | | | | | | | | | | | | | | | | | | | | | | | | | | | | | | | | | | | | | | | | | | | | | | | | | | | | | | | | | | | | | | | | | | | | | | | | | | | | | | | | | | | | | | | | | | | | | | | | | | | | | | | | | | | | | | | | | |
| 14* | 2 1/2 - 5 1/2 | | B | | N/A | B | | | | | | | | | | | | | | | | | | | | | | | | | | | | | | | | | | | | | | | | | | | | | | | | | | | | | | | | | | | | | | | | | | | | | | | | | | | | | | | | | | | | | | | | | | | | | | | | | | | | | | | | | | | | | | | | | | | | | | | | | | | | | | | | | | | | | |
| <p>Cap Fixed Clevis</p>  <p>Model 84</p> <p>(NFPA MP1) Pivot Pin Included</p> | <p>Cap Fixed Eye with Spherical Bearing</p>  <p>Model 94</p> <p>(NFPA MPU3)</p> | | | | | | | | | | | | | | | | | | | | | | | | | | | | | | | | | | | | | | | | | | | | | | | | | | | | | | | | | | | | | | | | | | | | | | | | | | | | | | | | | | | | | | | | | | | | | | | | | | | | | | | | | | | | | | | | | | | | | | | | | | | | | | | | | | | | | | | | | | |
| <p>Double End Construction</p>  | | | | | | | | | | | | | | | | | | | | | | | | | | | | | | | | | | | | | | | | | | | | | | | | | | | | | | | | | | | | | | | | | | | | | | | | | | | | | | | | | | | | | | | | | | | | | | | | | | | | | | | | | | | | | | | | | | | | | | | | | | | | | | | | | | | | | | | | | | | |
| <p>Available in all bore and rod combinations in the following models: 72, 74, 51, 53, 81, 89, and 61 (1" - 6"), 65 (1" - 6") and 63 (8" - 14").</p> | | | | | | | | | | | | | | | | | | | | | | | | | | | | | | | | | | | | | | | | | | | | | | | | | | | | | | | | | | | | | | | | | | | | | | | | | | | | | | | | | | | | | | | | | | | | | | | | | | | | | | | | | | | | | | | | | | | | | | | | | | | | | | | | | | | | | | | | | | | |

NOTE: See "How to Order" page for bushing retainer dimensions. Standard pricing applies to "B" and "R" configurations listed above. For alternative construction consult the factory.

The inside story on why AV Series is your best choice in heavy duty air cylinders.

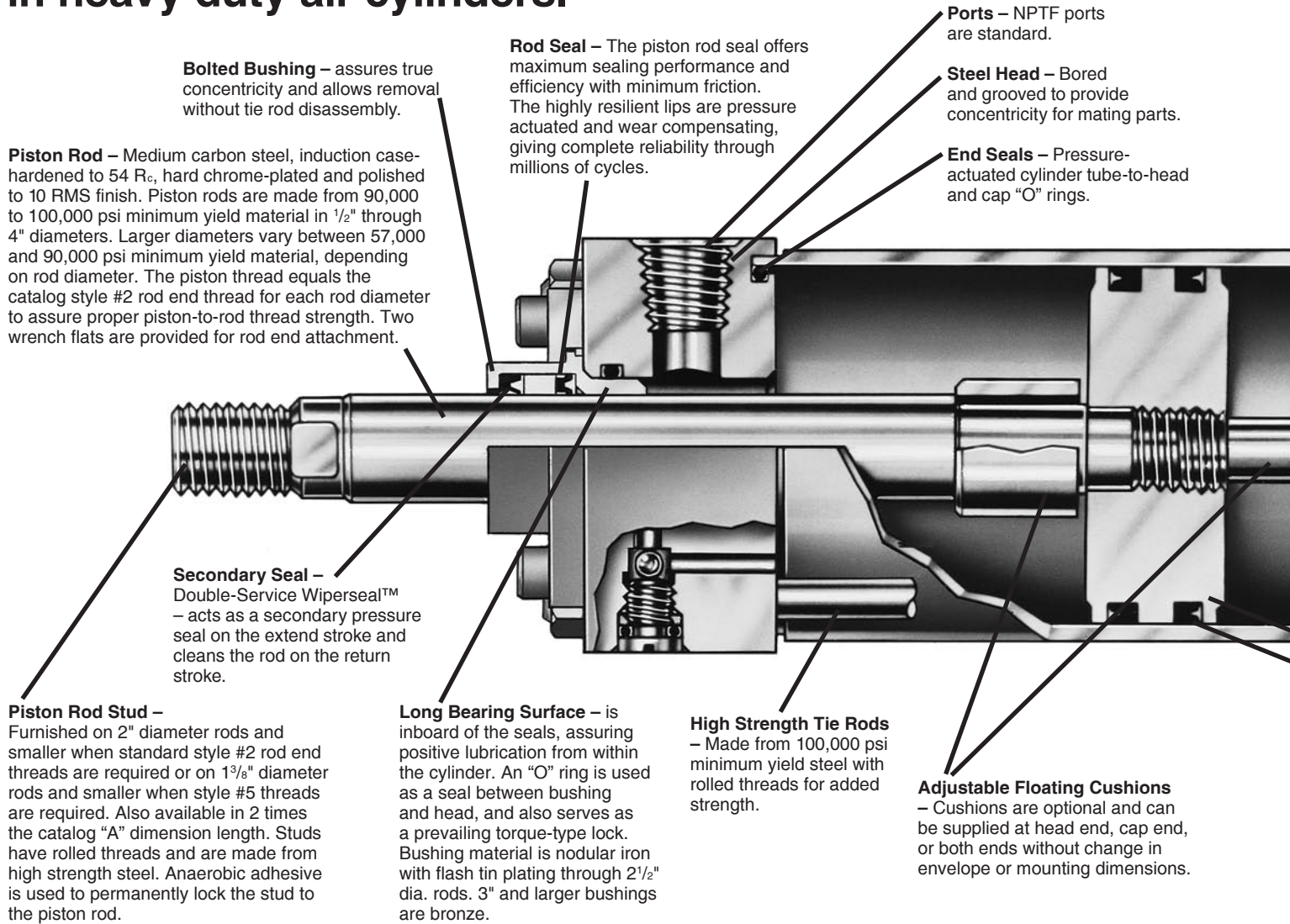

Adjustable floating cushions

Cushions are optional, and can be supplied at head end, cap end, or both ends without change in envelope or mounting dimensions. Cushions are adjustable.

The AV Series cylinder design incorporates the longest cushion plungers that can be provided in the standard envelope without decreasing the rod bearing and piston bearing lengths.

on the face opposite the needle valve except on models 81, 82 and 89 where it is mounted on side number 3, next to the needle valve. It may be identified by the fact that it is slotted.

d. The check and needle valves are interchangeable in the head.

- (1) When a cushion is specified at the head end:
 - a. A self-centering plunger is furnished on the piston rod assembly.
 - b. A needle valve is provided that is flush with the side of the head when wide open. It may be identified by the fact that it is socket-keyed. It is located on side number 2, in all mountings except 81, 82 and 89. In these models it is located on side number 3.
 - c. A springless check valve is provided that is also flush with the side of the head and is mounted

- (2) When a cushion is specified at the cap end:
 - a. A cushion plunger is provided on the piston rod assembly.
 - b. A "float check" self-centering bushing is provided which incorporates a large flow check valve for fast "out-stroke" action.
 - c. A socket-keyed needle valve is provided that is flush with the side of the cap when wide open. It is located on side number 2 in all mountings except 81, 82 and 89. In these models it is located on side number 3.

Prelubricated Wearing Surfaces

Miller Fluid Power AV Series Air Cylinders are factory prelubricated. Lube-A-Cyl applied to seals, piston, cylinder bore, piston rod and bushing surfaces provides lubrication for normal operation.

Lube-A-Cyl has been field and laboratory tested, and is recommended by Miller Fluid Power for air cylinders where lubricant should remain in the cylinder and not be expelled into the atmosphere.

Piston with Retainer Nut –
Optional at extra charge.

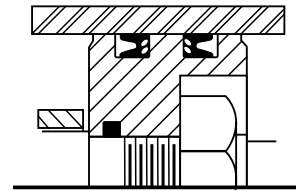

Note: Threaded rod bushings are supplied on cylinders with rod diameters over 2 1/2".

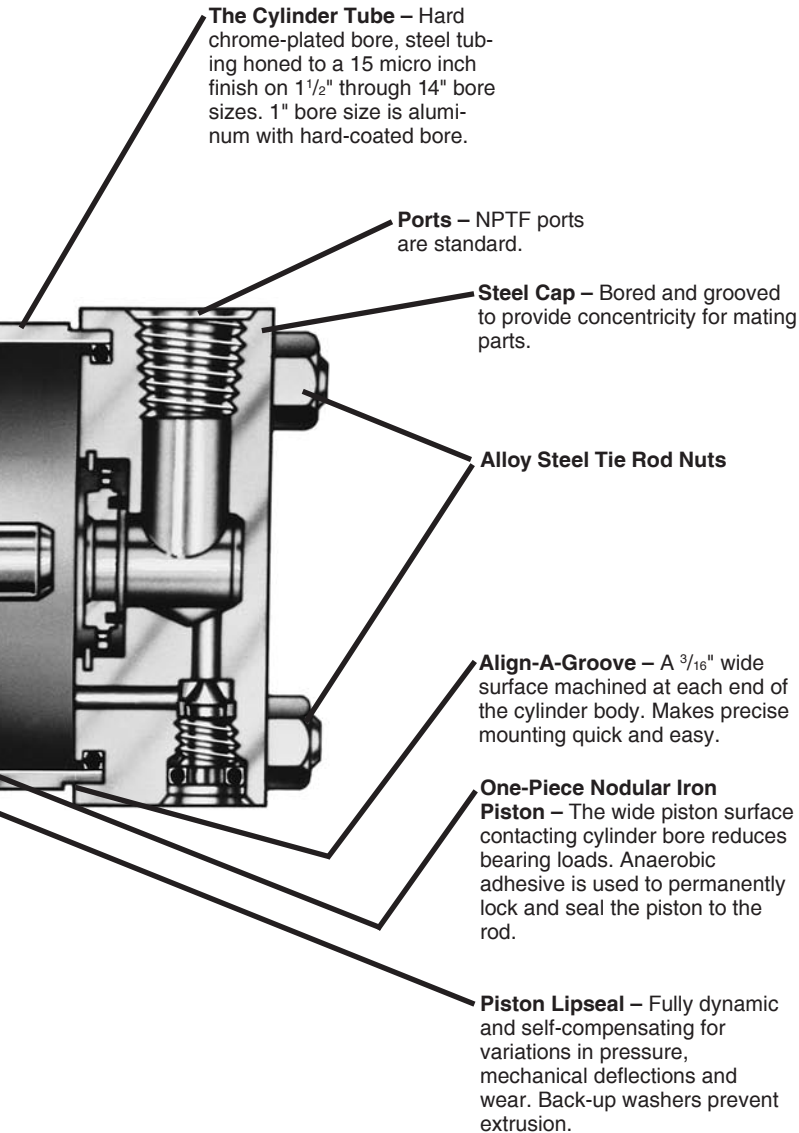

Cushion Length

| Cylinder Bore (Inches) | Rod Diameter* (Inches) | Cushion Length (Inches) | |
|------------------------|------------------------|-------------------------|-------|
| | | Head* | Cap |
| 1 1/2 | 5/8 | 7/8 | 13/16 |
| | 1 | 7/8 | 13/16 |
| 2 | 5/8 | 7/8 | 13/16 |
| | 1 3/8 | 7/8 | 13/16 |
| 2 1/2 | 5/8 | 7/8 | 13/16 |
| | 1 3/4 | 7/8 | 13/16 |
| 3 1/4 | 1 | 1 1/8 | 1 |
| | 2 | 1 3/16 | 1 |
| 4 | 1 | 1 1/8 | 1 |
| | 2 1/2 | 1 3/16 | 1 |
| 5 | 1 | 1 1/8 | 1 |
| | 3 1/2 | 1 3/16 | 1 |

| Cylinder Bore (Inches) | Rod Diameter* (Inches) | Cushion Length (Inches) | |
|------------------------|------------------------|-------------------------|-------|
| | | Head* | Cap |
| 6 | 1 3/8 | 1 3/8 | 1 1/4 |
| | 4 | 1 1/16 | 1 1/4 |
| 7 | 1 3/8 | 1 1/16 | 1 1/4 |
| | 2 | 1 1/16 | 1 1/4 |
| 8 | 1 3/8 | 1 1/16 | 1 1/4 |
| | 5 1/2 | 1 5/16 | 1 1/4 |
| 10 | 1 3/4 | 1 5/16 | 1 3/4 |
| | 5 1/2 | 1 3/16 | 1 3/4 |
| 12 | 2 | 1 5/16 | 1 3/4 |
| | 5 1/2 | 1 3/16 | 1 3/4 |
| 14 | 2 1/2 | 1 3/4 | 2 |
| | 5 1/2 | 1 11/16 | 2 |

*Head end cushions for rod diameters not listed have cushion lengths with the limits shown.

NOTE: Cushions not available on 1" bore.

Miller AV Series Heavy-Duty Air Cylinders

Side Lug Mount – 1" to 6" Bore Sizes

Side Lug Mount

Model 72

1" - 1 1/2" - 2" - 2 1/2" - 5" and 6" Bore

With Maximum Oversize Rods

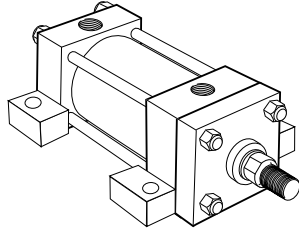

Retainer Held Bushing

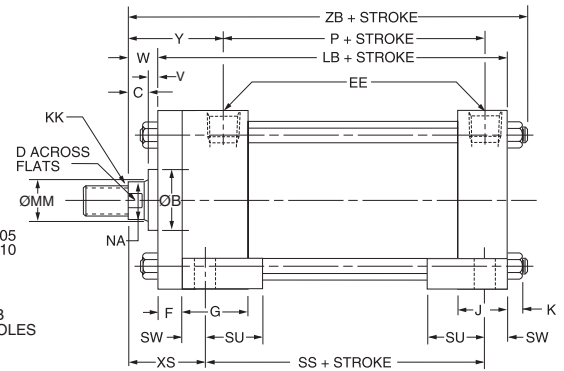
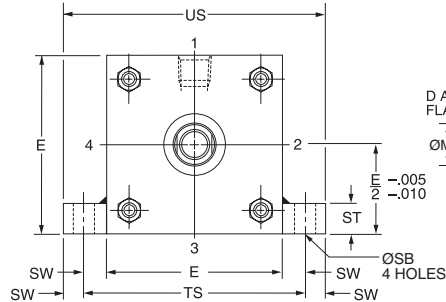

Before determining dimensions: See chart on page 3 for cylinder rod combinations that have removable bushings.

Side Lug Mount

Model 72

1 1/2" - 6" Bore

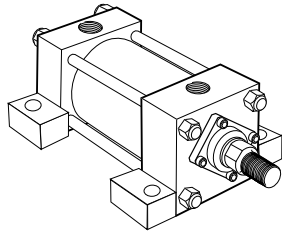

Bolted Bushing

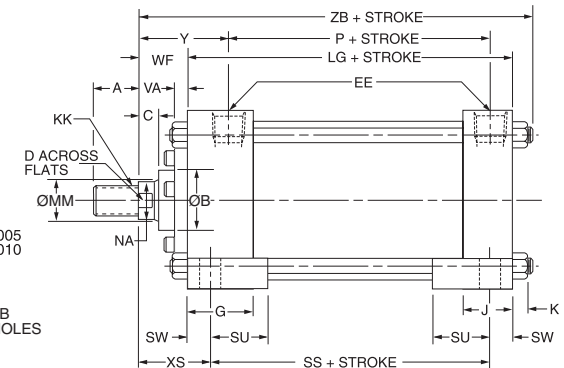
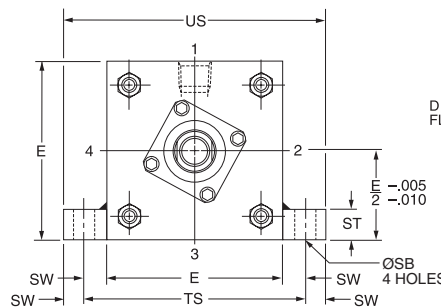

Rod End Dimensions — see table 2

Thread Style 2

Small Male

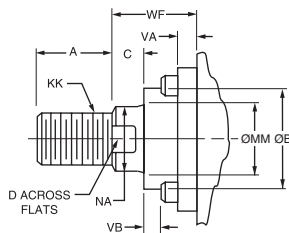

Thread Style 4

Short Female

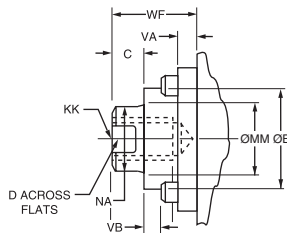

Thread Style 5

Intermediate Male

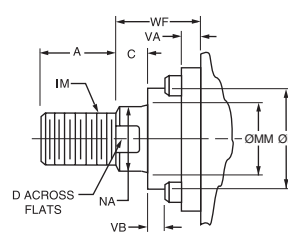

"Special" Thread Style X

Special thread, extension, rod eye, blank, etc., are also available.

To order, specify "Style X" and give desired dimensions for KK, A, W or WF. If otherwise special, furnish dimensioned sketch.

A high strength rod end stud is supplied on thread style 2 through 2" diameter rods and on thread style 5 through 1 3/8" diameter rods. Larger sizes or special rod ends are cut threads. Style 2 rod ends are recommended where the workpiece is secured against the rod shoulder. When the workpiece is not shouldered, style 2 rod ends

are recommended through 2" piston rod diameters and style 5 rod ends are recommended on larger diameters. Use style 4 for applications where female rod ends are required. If rod end is not specified, style 2 will be supplied.

Miller AV Series Heavy-Duty Air Cylinders

Side Lug Mount – 1" to 6" Bore Sizes

| Bore | E | EE NPTF | F | G | J | K | SB• (Bolt) | ST | SU | SW | TS | US | Add Stroke | | | |
|-------|-------|------------|-----|-------|-------|------|---------------|------|--------|--------|-------|-------|------------|-------|-------|-------|
| | | | | | | | | | | | | | LB | LG | P | SS |
| 1 | 1 1/2 | 1/4 | 3/8 | 1 1/2 | 1 | 3/16 | 1/4 | 5/16 | 3/4 | 5/16 | 2 3/8 | 2 3/4 | 3 7/8 | 3 1/2 | 2 1/8 | 2 7/8 |
| 1 1/2 | 2 | 3/8 | 3/8 | 1 1/2 | 1 | 1/4 | 3/8 | 1/2 | 15/16 | 3/8 | 2 3/4 | 3 1/2 | 4 | 3 5/8 | 2 1/4 | 2 7/8 |
| 2 | 2 1/2 | 3/8 | 3/8 | 1 1/2 | 1 | 5/16 | 3/8 | 1/2 | 15/16 | 3/8 | 3 1/4 | 4 | 4 | 3 5/8 | 2 1/4 | 2 7/8 |
| 2 1/2 | 3 | 3/8 | 3/8 | 1 1/2 | 1 | 5/16 | 3/8 | 1/2 | 15/16 | 3/8 | 3 3/4 | 4 1/2 | 4 1/8 | 3 3/4 | 2 3/8 | 3 |
| 3 1/4 | 3 3/4 | 1/2 | — | 1 3/4 | 1 1/4 | 3/8 | 1/2 | 3/4 | 1 1/4 | 1/2 | 4 3/4 | 5 3/4 | — | 4 1/4 | 2 5/8 | 3 1/4 |
| 4 | 4 1/2 | 1/2 | — | 1 3/4 | 1 1/4 | 3/8 | 1/2 | 3/4 | 1 1/4 | 1/2 | 5 1/2 | 6 1/2 | — | 4 1/4 | 2 5/8 | 3 1/4 |
| 5 | 5 1/2 | 1/2 | 5/8 | 1 3/4 | 1 1/4 | 7/16 | 3/4 | 1 | 1 9/16 | 1 1/16 | 6 7/8 | 8 1/4 | 5 1/8 | 4 1/2 | 2 7/8 | 3 1/8 |
| 6 | 6 1/2 | 3/4 | 3/4 | 2 | 1 1/2 | 7/16 | 3/4 | 1 | 1 9/16 | 1 1/16 | 7 7/8 | 9 1/4 | 5 3/4 | 5 | 3 1/8 | 3 5/8 |

† On 1 1/2", 2" and 2 1/2" bore sizes, the head-end (only) pipe thread is not full depth on cylinders with maximum oversize rods. Minimum of three full threads available.
■ 1" bore head is 1 3/4" x 1 1/2". • Mounting holes are 1/16" larger than bolt size listed.

Table 2—Rod Dimensions and Envelope Dimensions Affected by Rod Size

| Bore | MM Rod Ø | Thread | | Rod Extensions and Envelope Dimensions Affected By Rod Size | | | | | | | | | | | | | Add Stroke ZB |
|-------|----------------|------------------|----------------------|---|-----------------------|-----|---------|---------|-----|-----|--------|-------|-------|---------|---------|---------|------------------|
| | | Style 5 IM | Style 2 & 4 KK | A | B Ø +.000 -.002 | C | D | NA | V | VA | VB | W | WF | XS | Y | | |
| 1 | 1/2 | 7/16-20 | 5/16-24 | 5/8 | .999 | 3/8 | 3/8 | 7/16 | 1/4 | — | — | 5/8 | — | 1 5/16 | 1 5/16 | 4 11/16 | |
| | 5/8 | 1/2-20 | 7/16-20 | 3/4 | 1.124 | 3/8 | 1/2 | 9/16 | 1/4 | — | — | 5/8 | — | 1 5/16 | 1 5/16 | 4 11/16 | |
| 1 1/2 | 5/8 | 1/2-20 | 7/16-20 | 3/4 | 1.124 | 3/8 | 1/2 | 9/16 | — | 1/4 | 3/16 | — | 1 | 1 3/8 | 1 5/16 | 4 7/8 | |
| | 1 | 7/8-14 | 3/4-16 | 1 1/8 | 1.499 | 1/2 | 7/8 | 15/16 | 1/2 | — | — | 1 | — | 1 3/4 | 2 5/16 | 5 1/4 | |
| 2 | 5/8 | 1/2-20 | 7/16-20 | 3/4 | 1.124 | 3/8 | 1/2 | 9/16 | — | 1/4 | 3/16 | — | 1 | 1 3/8 | 1 5/16 | 4 15/16 | |
| | 1 3/8 | 1 1/4-12 | 1-14 | 1 5/8 | 1.999 | 5/8 | 1 1/8 | 1 5/16 | 5/8 | — | — | 1 1/4 | — | 2 | 2 9/16 | 5 9/16 | |
| 2 1/2 | 1 | 7/8-14 | 3/4-16 | 1 1/8 | 1.499 | 1/2 | 7/8 | 15/16 | — | 1/4 | 3/8 | — | 1 3/8 | 1 3/4 | 2 5/16 | 5 9/16 | |
| | 5/8 | 1/2-20 | 7/16-20 | 3/4 | 1.124 | 3/8 | 1/2 | 9/16 | — | 1/4 | 3/16 | — | 1 | 1 3/8 | 1 5/16 | 5 1/16 | |
| 3 1/4 | 1 3/8 | 1 1/4-12 | 1-14 | 1 5/8 | 1.999 | 5/8 | 1 1/8 | 1 5/16 | 5/8 | — | — | 1 1/4 | — | 2 | 2 9/16 | 5 11/16 | |
| | 1 3/4 | 1 1/2-12 | 1 1/4-12 | 2 | 2.374 | 3/4 | 1 1/2 | 1 11/16 | — | 1/4 | 3/8 | — | 1 1/2 | 2 1/4 | 2 13/16 | 5 15/16 | |
| 4 | 1 | 7/8-14 | 3/4-16 | 1 1/8 | 1.499 | 1/2 | 7/8 | 15/16 | — | 1/4 | 3/8 | — | 1 3/8 | 1 3/4 | 2 5/16 | 5 7/16 | |
| | 1 3/8 | 1 1/4-12 | 1-14 | 1 5/8 | 1.999 | 5/8 | 1 1/8 | 1 5/16 | — | 1/4 | 1/2 | — | 1 5/8 | 2 1/8 | 2 11/16 | 6 1/4 | |
| 5 | 1 3/4 | 1 1/2-12 | 1 1/4-12 | 2 | 2.374 | 3/4 | 1 1/2 | 1 11/16 | — | 1/4 | 9/16 | — | 1 7/8 | 2 3/8 | 2 15/16 | 6 1/2 | |
| | 2 | 1 3/4-12 | 1 1/2-12 | 2 1/4 | 2.624 | 7/8 | 1 11/16 | 1 5/16 | — | 1/4 | 9/16 | — | 2 | 2 1/2 | 3 1/16 | 6 5/8 | |
| 6 | 1 | 7/8-14 | 3/4-16 | 1 1/8 | 1.499 | 1/2 | 7/8 | 15/16 | — | 1/4 | 3/8 | — | 1 3/8 | 1 7/8 | 2 7/16 | 6 | |
| | 1 3/8 | 1 1/4-12 | 1-14 | 1 5/8 | 1.999 | 5/8 | 1 1/8 | 1 5/16 | — | 1/4 | 1/2 | — | 1 5/8 | 2 1/8 | 2 11/16 | 6 7/8 | |
| 7 | 1 3/4 | 1 1/2-12 | 1 1/4-12 | 2 | 2.374 | 3/4 | 1 1/2 | 1 11/16 | — | 1/4 | 9/16 | — | 1 7/8 | 2 3/8 | 2 15/16 | 6 1/4 | |
| | 2 | 1 3/4-12 | 1 1/2-12 | 2 1/4 | 2.624 | 7/8 | 1 11/16 | 1 5/16 | — | 1/4 | 9/16 | — | 2 | 2 1/2 | 3 1/16 | 6 1/2 | |
| 8 | 1 3/8 | 1 1/4-12 | 1-14 | 1 5/8 | 1.999 | 5/8 | 1 1/8 | 1 5/16 | — | 1/4 | 1/2 | — | 1 5/8 | 2 1/8 | 2 11/16 | 6 9/16 | |
| | 1 3/4 | 1 1/2-12 | 1 1/4-12 | 2 | 2.374 | 3/4 | 1 1/2 | 1 11/16 | — | 1/4 | 9/16 | — | 1 7/8 | 2 3/8 | 2 15/16 | 6 13/16 | |
| 9 | 1 3/4 | 1 1/2-12 | 1 1/4-12 | 2 | 2.374 | 3/4 | 1 1/2 | 1 11/16 | — | 1/4 | 9/16 | — | 2 | 2 11/16 | 3 1/16 | 6 15/16 | |
| | 2 1/2 | 2 1/4-12 | 1 7/8-12 | 3 | 3.124 | 1 | 2 1/16 | 2 3/8 | — | 1/4 | 1 1/16 | — | 2 1/4 | 2 5/16 | 3 5/16 | 7 3/16 | |
| 10 | 2 3/4 | 2 1/4-12 | 2 1/4-12 | 3 1/2 | 3.749 | 1 | 2 5/8 | 2 7/8 | 5/8 | — | — | 1 5/8 | — | 2 15/16 | 3 5/16 | 7 3/16 | |
| | 1 3/8 | 1 1/4-12 | 1-14 | 1 5/8 | 1.999 | 5/8 | 1 1/8 | 1 5/16 | — | 1/4 | 7/16 | — | 1 5/8 | 2 5/16 | 2 13/16 | 7 1/16 | |
| 11 | 1 3/4 | 1 1/2-12 | 1 1/4-12 | 2 | 2.374 | 3/4 | 1 1/2 | 1 11/16 | — | 1/4 | 9/16 | — | 1 7/8 | 2 3/8 | 3 1/16 | 7 5/16 | |
| | 2 | 1 3/4-12 | 1 1/2-12 | 2 1/4 | 2.624 | 7/8 | 1 11/16 | 1 5/16 | — | 1/4 | 9/16 | — | 2 | 2 11/16 | 3 3/16 | 7 7/16 | |
| 12 | 2 1/2 | 2 1/4-12 | 1 7/8-12 | 3 | 3.124 | 1 | 2 1/16 | 2 3/8 | — | 1/4 | 1 1/16 | — | 2 1/4 | 2 5/16 | 3 7/16 | 7 11/16 | |
| | 3 | 2 3/4-12 | 2 1/4-12 | 3 1/2 | 3.749 | 1 | 2 5/8 | 2 7/8 | 1/2 | — | — | 1 1/2 | — | 2 15/16 | 3 7/16 | 7 11/16 | |
| 13 | 1 3/8 | 1 1/4-12 | 1-14 | 1 5/8 | 1.999 | 5/8 | 1 1/8 | 1 5/16 | — | 1/4 | 7/16 | — | 1 5/8 | 2 5/16 | 2 13/16 | 7 1/16 | |
| | 1 3/4 | 1 1/2-12 | 1 1/4-12 | 2 | 2.374 | 3/4 | 1 1/2 | 1 11/16 | — | 1/4 | 9/16 | — | 1 7/8 | 2 3/8 | 3 1/16 | 7 5/16 | |
| 14 | 2 | 1 3/4-12 | 1 1/2-12 | 2 1/4 | 2.624 | 7/8 | 1 11/16 | 1 5/16 | — | 1/4 | 9/16 | — | 2 | 2 11/16 | 3 3/16 | 7 7/16 | |
| | 2 1/2 | 2 1/4-12 | 1 7/8-12 | 3 | 3.124 | 1 | 2 1/16 | 2 3/8 | — | 1/4 | 1 1/16 | — | 2 1/4 | 2 5/16 | 3 7/16 | 7 11/16 | |
| 15 | 3 | 2 3/4-12 | 2 1/4-12 | 3 1/2 | 3.749 | 1 | 2 5/8 | 2 7/8 | 1/2 | — | — | 1 1/2 | — | 2 15/16 | 3 7/16 | 7 11/16 | |
| | 3 1/2 | 3 1/4-12 | 2 1/2-12 | 3 1/2 | 4.249 | 1 | 3 | 3 3/8 | 5/8 | — | — | 1 5/8 | — | 2 15/16 | 3 5/16 | 7 3/16 | |

Rod End Dimensions — see table 2

Thread Style 2 Small Male

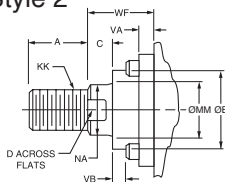

Thread Style 4 Short Female

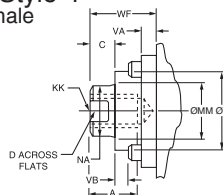

Thread Style 5 Intermediate Male

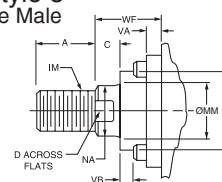

A high strength rod end stud is supplied on thread style 2 through 2" diameter rods and on thread style 5 through 1 3/8" diameter rods. Larger sizes or special rod ends are cut threads. Style 2 rod ends are recommended where the workpiece is secured against the rod shoulder. When the workpiece is not

shouldered, style 2 rod ends are recommended through 2" piston rod diameters and style 5 rod ends are recommended on larger diameters. Use style 4 for applications where female rod end threads are required. If rod end is not specified, style 2 will be supplied.

"Special" Thread Style X

Special thread, extension, rod eye, blank, etc., are also available.

To order, specify "Style X" and give desired dimensions for KK, A, W or WF. If otherwise special, furnish dimensioned sketch.

Miller AV Series Heavy-Duty Air Cylinders

Side Tap Mount
1" to 6" Bore Sizes

Side Tap Mount

Model 74

1" - 1 1/2" - 2" - 2 1/2" - 5" and 6" Bore
With Maximum Oversize Rods

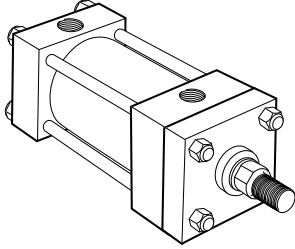

Retainer Held Bushing

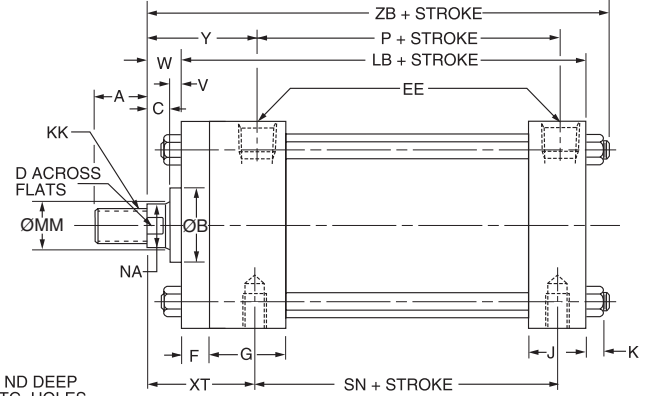
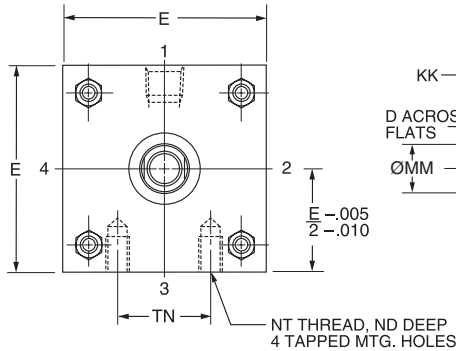

Before determining dimensions: See chart on page 3 for cylinder rod combinations that have removable bushings.

Side Tap Mount

Model 74

1 1/2" - 6" Bore

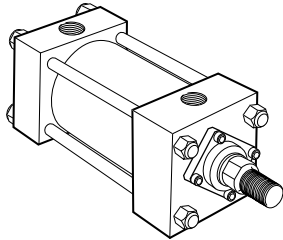

Bolted Bushing

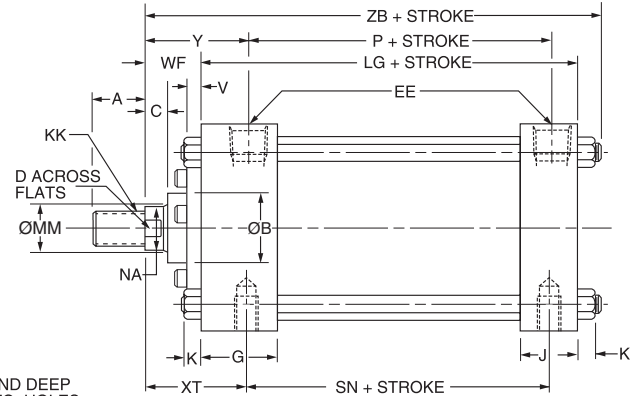
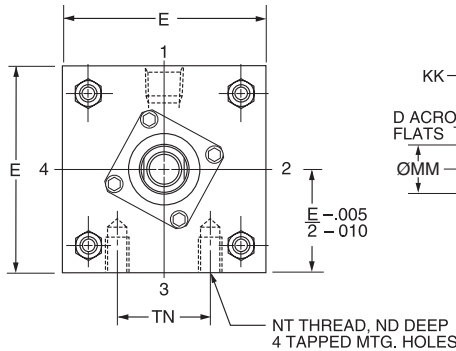

Rod End Dimensions — see table 2

Thread Style 2

Small Male

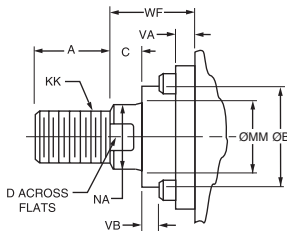

Thread Style 4

Short Female

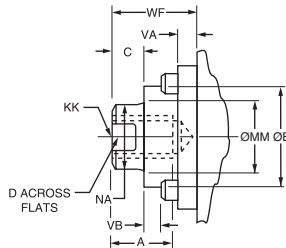

Thread Style 5

Intermediate Male

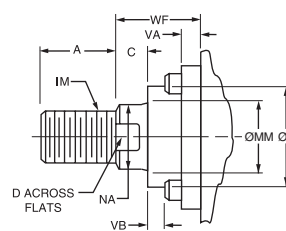

"Special" Thread Style X

Special thread, extension, rod eye, blank, etc., are also available.

To order, specify "Style X" and give desired dimensions for KK, A, W or WF. If otherwise special, furnish dimensioned sketch.

A high strength rod end stud is supplied on thread style 2 through 2" diameter rods and on thread style 5 through 1 3/8" diameter rods. Larger sizes or special rod ends are cut threads. Style 2 rod ends are recommended where the workpiece is secured against the rod shoulder. When the workpiece is not shouldered, style 2 rod ends

are recommended through 2" piston rod diameters and style 5 rod ends are recommended on larger diameters. Use style 4 for applications where female rod end threads are required. If rod end is not specified, style 2 will be supplied.

Miller AV Series Heavy-Duty Air Cylinders

Side Tap Mount
1" to 6" Bore Sizes

Table 1—Envelope and Mounting Dimensions

| Bore | E | EE NPTF | F | G | J | K | TN | NT | Add Stroke | | | |
|-------|-------|------------|-----|-------|-------|------|---------|---------|------------|-------|-------|-------|
| | | | | | | | | | LB | LG | P | SN |
| 1 | ■ | 1/4 | 3/8 | 1 1/2 | 1 | 3/16 | 9/16 | 10-24 | 3 7/8 | — | 2 1/8 | 2 1/8 |
| 1 1/2 | 2 | 3/8† | 3/8 | 1 1/2 | 1 | 1/4 | 5/8 | 1/4-20 | 4 | 3 5/8 | 2 1/4 | 2 1/4 |
| 2 | 2 1/2 | 3/8† | 3/8 | 1 1/2 | 1 | 5/16 | 7/8 | 5/16-18 | 4 | 3 5/8 | 2 1/4 | 2 1/4 |
| 2 1/2 | 3 | 3/8† | 3/8 | 1 1/2 | 1 | 5/16 | 1 1/4 | 3/8-16 | 4 1/8 | 3 3/4 | 2 3/8 | 2 3/8 |
| 3 1/4 | 3 3/4 | 1/2 | — | 1 3/4 | 1 1/4 | 3/8 | 1 1/2 | 1/2-13 | — | 4 1/4 | 2 5/8 | 2 5/8 |
| 4 | 4 1/2 | 1/2 | — | 1 3/4 | 1 1/4 | 3/8 | 2 1/16 | 1/2-13 | — | 4 1/4 | 2 5/8 | 2 5/8 |
| 5 | 5 1/2 | 1/2 | 5/8 | 1 3/4 | 1 1/4 | 7/16 | 2 11/16 | 5/8-11 | 5 1/8 | 4 1/2 | 2 7/8 | 2 7/8 |
| 6 | 6 1/2 | 3/4 | 3/4 | 2 | 1 1/2 | 7/16 | 3 1/4 | 3/4-10 | — | 5 | 3 1/8 | 3 1/8 |

†On 1 1/2", 2" and 2 1/2" bore sizes, the head-end (only) pipe thread is not full depth on cylinders with maximum oversize rods. Minimum of three full threads available.

■ 1" bore head is 1 3/4" x 1 1/2".

Table 2—Rod Dimensions and Envelope Dimensions Affected by Rod Size

| Bore | MM Rod Ø | Thread | | Rod Extensions and Envelope Dimensions Affected By Rod Size | | | | | | | | | | | | | | Add Stroke |
|-------|----------------|------------------|----------------------|---|-----------------------|-----|---------|---------|-----|-----|--------|-------|-------|---------|---------|-------|---------|------------|
| | | Style 5 IM | Style 2 & 4 KK | A | B Ø +.000 -.002 | C | D | NA | V | VA | VB | W | WF | XT | Y | ND | ZB | |
| | | | | | | | | | | | | | | | | | ZB | |
| 1 | 1/2 | 7/16-20 | 5/16-24 | 5/8 | .999 | 3/8 | 3/8 | 7/16 | 1/4 | — | — | 5/8 | — | 1 5/16 | 1 5/16 | 1/4 | 4 11/16 | |
| | 5/8 | 1/2-20 | 7/16-20 | 3/4 | 1.124 | 3/8 | 1/2 | 9/16 | 1/4 | — | — | 5/8 | — | 1 5/16 | 1 5/16 | 1/4 | 4 11/16 | |
| 1 1/2 | 5/8 | 1/2-20 | 7/16-20 | 3/4 | 1.124 | 3/8 | 1/2 | 9/16 | — | 1/4 | 3/16 | — | 1 | 1 5/16 | 1 5/16 | 3/8 | 4 7/8 | |
| | 1 | 7/8-14 | 3/4-16 | 1 1/8 | 1.499 | 1/2 | 7/8 | 1 5/16 | 1/2 | — | — | 1 | — | 2 5/16 | 2 5/16 | 3/8 | 5 1/4 | |
| 2 | 5/8 | 1/2-20 | 7/16-20 | 3/4 | 1.124 | 3/8 | 1/2 | 9/16 | — | 1/4 | 3/16 | — | 1 | 1 5/16 | 1 3/16 | 11/32 | 4 15/16 | |
| | 1 3/8 | 1 1/4-12 | 1-14 | 1 5/8 | 1.999 | 5/8 | 1 1/8 | 1 5/16 | 5/8 | — | — | 1 1/4 | — | 2 9/16 | 2 9/16 | 11/32 | 5 9/16 | |
| 2 1/2 | 1 | 7/8-14 | 3/4-16 | 1 1/8 | 1.499 | 1/2 | 7/8 | 1 5/16 | — | 1/4 | 3/8 | — | 1 3/8 | 2 5/16 | 2 5/16 | 11/32 | 5 5/16 | |
| | 1 3/8 | 1 1/4-12 | 1-14 | 1 5/8 | 1.999 | 5/8 | 1 1/8 | 1 5/16 | 5/8 | — | — | 1 1/4 | — | 2 9/16 | 2 9/16 | 7/16 | 5 11/16 | |
| 3 1/4 | 1 | 7/8-14 | 3/4-16 | 1 1/8 | 1.499 | 1/2 | 7/8 | 1 5/16 | — | 1/4 | 3/8 | — | 1 3/8 | 2 7/16 | 2 7/16 | 1/2 | 6 | |
| | 2 | 1 3/4-12 | 1 1/2-12 | 2 1/4 | 2.624 | 7/8 | 1 11/16 | 1 5/16 | — | 1/4 | 9/16 | — | 2 | 3 1/16 | 3 1/16 | 1/2 | 6 5/8 | |
| 4 | 1 3/8 | 1 1/4-12 | 1-14 | 1 5/8 | 1.999 | 5/8 | 1 1/8 | 1 5/16 | — | 1/4 | 1/2 | — | 1 5/8 | 2 11/16 | 2 11/16 | 5/8 | 6 1/4 | |
| | 1 3/4 | 1 1/2-12 | 1 1/4-12 | 2 | 2.374 | 3/4 | 1 1/2 | 1 11/16 | — | 1/4 | 9/16 | — | 1 7/8 | 2 15/16 | 2 15/16 | 5/8 | 6 1/2 | |
| 5 | 2 | 1 3/4-12 | 1 1/2-12 | 2 1/4 | 2.624 | 7/8 | 1 11/16 | 1 5/16 | — | 1/4 | 9/16 | — | 2 | 3 1/16 | 3 1/16 | 5/8 | 6 5/8 | |
| | 2 1/2 | 2 1/4-12 | 1 7/8-12 | 3 | 3.124 | 1 | 2 1/16 | 2 3/8 | — | 1/4 | 1 1/16 | — | 2 1/4 | 3 5/16 | 3 5/16 | 3/4 | 7 3/16 | |
| 6 | 1 | 7/8-14 | 3/4-16 | 1 1/8 | 1.499 | 1/2 | 7/8 | 1 5/16 | — | 1/4 | 3/8 | — | 1 3/8 | 2 7/16 | 2 7/16 | 3/4 | 6 5/16 | |
| | 3 1/2 | 3 1/4-12 | 2 1/2-12 | 3 1/2 | 4.249 | 1 | 3 | 3 3/8 | 5/8 | — | — | 1 5/8 | — | 3 5/16 | 3 5/16 | 3/4 | 7 3/16 | |
| 7 | 1 3/8 | 1 1/4-12 | 1-14 | 1 5/8 | 1.999 | 5/8 | 1 1/8 | 1 5/16 | — | 1/4 | 1/2 | — | 1 5/8 | 2 11/16 | 2 11/16 | 3/4 | 6 9/16 | |
| | 1 3/4 | 1 1/2-12 | 1 1/4-12 | 2 | 2.374 | 3/4 | 1 1/2 | 1 11/16 | — | 1/4 | 9/16 | — | 1 7/8 | 2 15/16 | 2 15/16 | 3/4 | 6 13/16 | |
| 8 | 2 | 1 3/4-12 | 1 1/2-12 | 2 1/4 | 2.624 | 7/8 | 1 11/16 | 1 5/16 | — | 1/4 | 9/16 | — | 2 | 3 1/16 | 3 1/16 | 3/4 | 6 15/16 | |
| | 2 1/2 | 2 1/4-12 | 1 7/8-12 | 3 | 3.124 | 1 | 2 1/16 | 2 3/8 | — | 1/4 | 1 1/16 | — | 2 1/4 | 3 5/16 | 3 5/16 | 3/4 | 7 3/16 | |
| 9 | 3 | 2 3/4-12 | 2 1/4-12 | 3 1/2 | 3.749 | 1 | 2 5/8 | 2 7/8 | 5/8 | — | — | 1 5/8 | — | 3 5/16 | 3 5/16 | 3/4 | 7 3/16 | |
| | 1 3/8 | 1 1/4-12 | 1-14 | 1 5/8 | 1.999 | 5/8 | 1 1/8 | 1 5/16 | — | 1/4 | 7/16 | — | 1 5/8 | 2 13/16 | 2 13/16 | 7/8 | 7 1/16 | |
| 10 | 4 | 3 3/4-12 | 3-12 | 4 | 4.749 | 1 | 3 3/8 | 3 7/8 | 1/2 | — | — | 1 1/2 | — | 3 7/16 | 3 7/16 | 7/8 | 7 11/16 | |
| | 1 3/4 | 1 1/2-12 | 1 1/4-12 | 2 | 2.374 | 3/4 | 1 1/2 | 1 11/16 | — | 1/4 | 9/16 | — | 1 7/8 | 3 1/16 | 3 1/16 | 7/8 | 7 5/16 | |
| 11 | 2 | 1 3/4-12 | 1 1/2-12 | 2 1/4 | 2.624 | 7/8 | 1 11/16 | 1 5/16 | — | 1/4 | 9/16 | — | 2 | 3 3/16 | 3 3/16 | 7/8 | 7 7/16 | |
| | 2 1/2 | 2 1/4-12 | 1 7/8-12 | 3 | 3.124 | 1 | 2 1/16 | 2 3/8 | — | 1/4 | 1 1/16 | — | 2 1/4 | 3 7/16 | 3 7/16 | 7/8 | 7 11/16 | |
| 12 | 3 | 2 3/4-12 | 2 1/4-12 | 3 1/2 | 3.749 | 1 | 2 5/8 | 2 7/8 | 1/2 | — | — | 1 1/2 | — | 3 7/16 | 3 7/16 | 7/8 | 7 11/16 | |
| | 3 1/2 | 3 1/4-12 | 2 1/2-12 | 3 1/2 | 4.249 | 1 | 3 | 3 3/8 | 1/2 | — | — | 1 1/2 | — | 3 7/16 | 3 7/16 | 7/8 | 7 11/16 | |

Miller AV Series Heavy-Duty Air Cylinders

Head Rectangular Flange Mount
1" to 6" Bore Sizes

Head Rectangular Flange Mount
Model 61
1" - 6" Bore

Bolted
Bushing

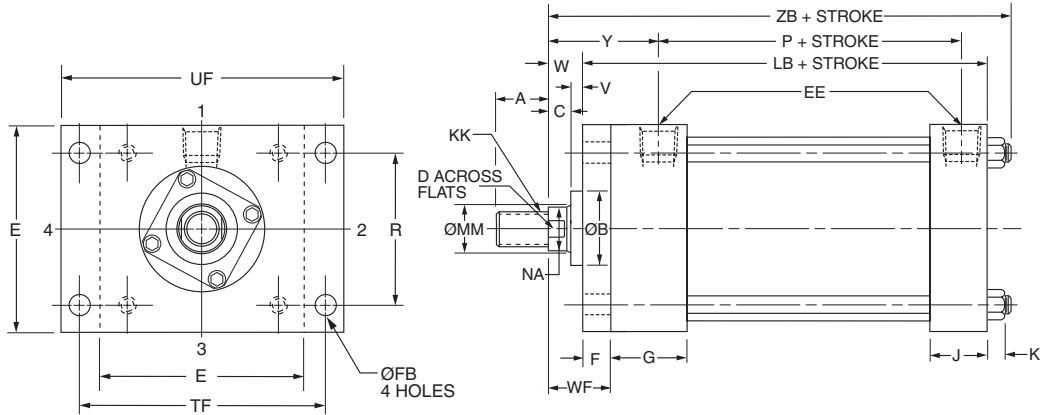
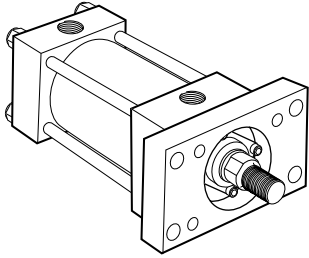

1" Bore Cylinder Only

1" Bore Cylinder Only
Head End

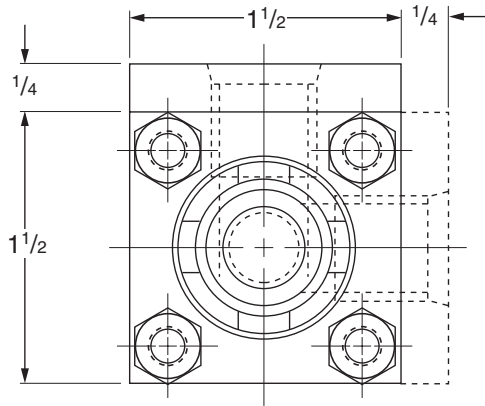

Rod End Dimensions — see table 2

Thread Style 2
Small Male

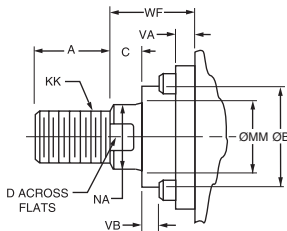

Thread Style 4
Short Female

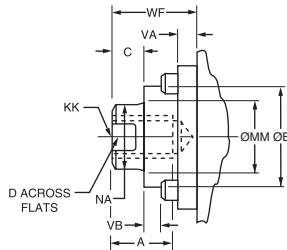

Thread Style 5
Intermediate Male

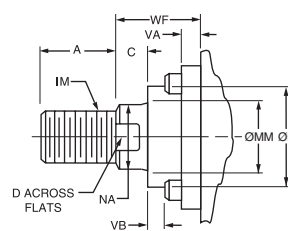

“Special” Thread
Style X

Special thread, extension, rod eye, blank, etc., are also available.

To order, specify “Style X” and give desired dimensions for KK, A, W or WF. If otherwise special, furnish dimensioned sketch.

A high strength rod end stud is supplied on thread style 2 through 2" diameter rods and on thread style 5 through 1 3/8" diameter rods. Larger sizes or special rod ends are cut threads. Style 2 rod ends are recommended where the workpiece is secured against the rod shoulder. When the workpiece is not shouldered, style 2 rod ends

are recommended through 2" piston rod diameters and style 5 rod ends are recommended on larger diameters. Use style 4 for applications where female rod end threads are required. If rod end is not specified, style 2 will be supplied.

Miller AV Series Heavy-Duty Air Cylinders

Head Rectangular Flange Mount
1" to 6" Bore Sizes

Table 1—Envelope and Mounting Dimensions

| Bore | E | EE NPTF | F | FB* (Bolt) | G | J | K | R | TF | UF | Add Stroke | |
|-------|-------|------------|-----|---------------|-------|-------|------|------|---------|-------|------------|-------|
| | | | | | | | | | | | LB | P |
| 1 | ■ | 1/4 | 3/8 | #10 | 1 1/2 | 1 | 3/16 | 1.08 | 2 | 2 1/2 | 3 7/8 | 2 1/8 |
| 1 1/2 | 2 | 3/8† | 3/8 | 1/4 | 1 1/2 | 1 | 1/4 | 1.43 | 2 3/4 | 3 3/8 | 4 | 2 1/4 |
| 2 | 2 1/2 | 3/8† | 3/8 | 5/16 | 1 1/2 | 1 | 5/16 | 1.84 | 3 3/8 | 4 1/8 | 4 | 2 1/4 |
| 2 1/2 | 3 | 3/8† | 3/8 | 5/16 | 1 1/2 | 1 | 5/16 | 2.19 | 3 7/8 | 4 5/8 | 4 1/8 | 2 3/8 |
| 3 1/4 | 3 3/4 | 1/2 | 5/8 | 3/8 | 1 3/4 | 1 1/4 | 3/8 | 2.76 | 4 11/16 | 5 1/2 | 4 7/8 | 2 5/8 |
| 4 | 4 1/2 | 1/2 | 5/8 | 3/8 | 1 3/4 | 1 1/4 | 3/8 | 3.32 | 5 7/16 | 6 1/4 | 4 7/8 | 2 5/8 |
| 5 | 5 1/2 | 1/2 | 5/8 | 1/2 | 1 3/4 | 1 1/4 | 7/16 | 4.10 | 6 5/8 | 7 5/8 | 5 1/8 | 2 7/8 |
| 6 | 6 1/2 | 3/4 | 3/4 | 1/2 | 2 | 1 1/2 | 7/16 | 4.88 | 7 5/8 | 8 5/8 | 5 3/4 | 3 1/8 |

† On 1 1/2", 2" and 2 1/2" bore sizes, the head-end (only) pipe thread is not full depth on cylinders with maximum oversize rods. Minimum of three full threads available.

■ 1" bore head is 1 3/4" x 1 1/2".

*Mounting holes are 1/16" larger than bolt size listed.

Table 2—Rod Dimensions and Envelope Dimensions Affected by Rod Size

| Bore | MM Rod Ø | Thread | | Rod Extensions and Envelope Dimensions Affected By Rod Size | | | | | | | | | Add Stroke | |
|-------|----------------|------------------|----------------------|---|-----------------------|-----|---------|---------|-----|-------|-------|---------|------------|--|
| | | Style 5 IM | Style 2 & 4 KK | A | B Ø +.000 -.002 | C | D | NA | V | W | WF | Y | ZB | |
| | | | | | | | | | | | | | | |
| 1 | 1/2 | 7/16-20 | 5/16-24 | 5/8 | .999 | 3/8 | 3/8 | 7/16 | 1/4 | 5/8 | 1 | 1 15/16 | 4 11/16 | |
| | 5/8 | 1/2-20 | 7/16-20 | 3/4 | 1.124 | 3/8 | 1/2 | 9/16 | 1/4 | 5/8 | 1 | 1 15/16 | 4 11/16 | |
| 1 1/2 | 5/8 | 1/2-20 | 7/16-20 | 3/4 | 1.124 | 3/8 | 1/2 | 9/16 | 1/4 | 5/8 | 1 | 1 15/16 | 4 7/8 | |
| | 1 | 7/8-14 | 3/4-16 | 1 1/8 | 1.499 | 1/2 | 7/8 | 15/16 | 1/2 | 1 | 1 3/8 | 2 5/16 | 5 1/4 | |
| 2 | 5/8 | 1/2-20 | 7/16-20 | 3/4 | 1.124 | 3/8 | 1/2 | 9/16 | 1/4 | 5/8 | 1 | 1 15/16 | 4 15/16 | |
| | 1 3/8 | 1 1/4-12 | 1-14 | 1 5/8 | 1.999 | 5/8 | 1 1/8 | 1 5/16 | 5/8 | 1 1/4 | 1 5/8 | 2 9/16 | 5 9/16 | |
| 2 1/2 | 1 | 7/8-14 | 3/4-16 | 1 1/8 | 1.499 | 1/2 | 7/8 | 15/16 | 1/2 | 1 | 1 3/8 | 2 5/16 | 5 5/16 | |
| | 5/8 | 1/2-20 | 7/16-20 | 3/4 | 1.124 | 3/8 | 1/2 | 9/16 | 1/4 | 5/8 | 1 | 1 15/16 | 5 1/16 | |
| 2 1/2 | 1 3/4 | 1 1/2-12 | 1 1/4-12 | 2 | 2.374 | 3/4 | 1 1/2 | 1 11/16 | 3/4 | 1 1/2 | 1 7/8 | 2 13/16 | 5 15/16 | |
| | 1 | 7/8-14 | 3/4-16 | 1 1/8 | 1.499 | 1/2 | 7/8 | 15/16 | 1/2 | 1 | 1 3/8 | 2 5/16 | 5 7/16 | |
| 3 1/4 | 1 3/8 | 1 1/4-12 | 1-14 | 1 5/8 | 1.999 | 5/8 | 1 1/8 | 1 5/16 | 5/8 | 1 1/4 | 1 5/8 | 2 9/16 | 5 11/16 | |
| | 1 | 7/8-14 | 3/4-16 | 1 1/8 | 1.499 | 1/2 | 7/8 | 15/16 | 1/4 | 3/4 | 1 3/8 | 2 7/16 | 6 | |
| 3 1/4 | 2 | 1 3/4-12 | 1 1/2-12 | 2 1/4 | 2.624 | 7/8 | 1 11/16 | 1 15/16 | 1/2 | 1 3/8 | 2 | 3 1/16 | 6 5/8 | |
| | 1 3/8 | 1 1/4-12 | 1-14 | 1 5/8 | 1.999 | 5/8 | 1 1/8 | 1 5/16 | 3/8 | 1 | 1 5/8 | 2 11/16 | 6 1/4 | |
| 3 1/4 | 1 3/4 | 1 1/2-12 | 1 1/4-12 | 2 | 2.374 | 3/4 | 1 1/2 | 1 11/16 | 1/2 | 1 1/4 | 1 7/8 | 2 15/16 | 6 1/2 | |
| | 1 | 7/8-14 | 3/4-16 | 1 1/8 | 1.499 | 1/2 | 7/8 | 15/16 | 1/4 | 3/4 | 1 3/8 | 2 7/16 | 6 | |
| 4 | 2 1/2 | 2 1/4-12 | 1 7/8-12 | 3 | 3.124 | 1 | 2 1/16 | 2 3/8 | 5/8 | 1 5/8 | 2 1/4 | 3 5/16 | 6 7/8 | |
| | 1 3/8 | 1 1/4-12 | 1-14 | 1 5/8 | 1.999 | 5/8 | 1 1/8 | 1 5/16 | 3/8 | 1 | 1 5/8 | 2 11/16 | 6 1/4 | |
| 4 | 1 3/4 | 1 1/2-12 | 1 1/4-12 | 2 | 2.374 | 3/4 | 1 1/2 | 1 11/16 | 1/2 | 1 1/4 | 1 7/8 | 2 15/16 | 6 1/2 | |
| | 2 | 1 3/4-12 | 1 1/2-12 | 2 1/4 | 2.624 | 7/8 | 1 11/16 | 1 15/16 | 1/2 | 1 3/8 | 2 | 3 1/16 | 6 5/8 | |
| 4 | 2 1/2 | 2 1/4-12 | 1 7/8-12 | 3 | 3.124 | 1 | 2 1/16 | 2 3/8 | 5/8 | 1 5/8 | 2 1/4 | 3 5/16 | 6 7/8 | |
| | 3 | 2 3/4-12 | 2 1/4-12 | 3 1/2 | 3.749 | 1 | 2 5/8 | 2 7/8 | 5/8 | 1 5/8 | 2 1/4 | 3 5/16 | 7 3/16 | |
| 5 | 1 | 7/8-14 | 3/4-16 | 1 1/8 | 1.499 | 1/2 | 7/8 | 15/16 | 1/4 | 3/4 | 1 3/8 | 2 7/16 | 6 5/16 | |
| | 3 1/2 | 3 1/4-12 | 2 1/2-12 | 3 1/2 | 4.249 | 1 | 3 | 3 3/8 | 5/8 | 1 5/8 | 2 1/4 | 3 5/16 | 7 3/16 | |
| 5 | 1 3/8 | 1 1/4-12 | 1-14 | 1 5/8 | 1.999 | 5/8 | 1 1/8 | 1 5/16 | 3/8 | 1 | 1 5/8 | 2 11/16 | 6 9/16 | |
| | 1 3/4 | 1 1/2-12 | 1 1/4-12 | 2 | 2.374 | 3/4 | 1 1/2 | 1 11/16 | 1/2 | 1 1/4 | 1 7/8 | 2 15/16 | 6 13/16 | |
| 5 | 2 | 1 3/4-12 | 1 1/2-12 | 2 1/4 | 2.624 | 7/8 | 1 11/16 | 1 15/16 | 1/2 | 1 3/8 | 2 | 3 1/16 | 6 15/16 | |
| | 2 1/2 | 2 1/4-12 | 1 7/8-12 | 3 | 3.124 | 1 | 2 1/16 | 2 3/8 | 5/8 | 1 5/8 | 2 1/4 | 3 5/16 | 7 3/16 | |
| 5 | 3 | 2 3/4-12 | 2 1/4-12 | 3 1/2 | 3.749 | 1 | 2 5/8 | 2 7/8 | 5/8 | 1 5/8 | 2 1/4 | 3 5/16 | 7 3/16 | |
| | 1 3/8 | 1 1/4-12 | 1-14 | 1 5/8 | 1.999 | 5/8 | 1 1/8 | 1 5/16 | 1/4 | 7/8 | 1 5/8 | 2 13/16 | 7 1/16 | |
| 6 | 4 | 3 3/4-12 | 3-12 | 4 | 4.749 | 1 | 3 3/8 | 3 7/8 | 1/2 | 1 1/2 | 2 1/4 | 3 7/16 | 7 11/16 | |
| | 1 3/4 | 1 1/2-12 | 1 1/4-12 | 2 | 2.374 | 3/4 | 1 1/2 | 1 11/16 | 3/8 | 1 1/8 | 1 7/8 | 3 1/16 | 7 5/16 | |
| 6 | 2 | 1 3/4-12 | 1 1/2-12 | 2 1/4 | 2.624 | 7/8 | 1 11/16 | 1 15/16 | 3/8 | 1 1/4 | 2 | 3 3/16 | 7 7/16 | |
| | 2 1/2 | 2 1/4-12 | 1 7/8-12 | 3 | 3.124 | 1 | 2 1/16 | 2 3/8 | 1/2 | 1 1/2 | 2 1/4 | 3 7/16 | 7 11/16 | |
| 6 | 3 | 2 3/4-12 | 2 1/4-12 | 3 1/2 | 3.749 | 1 | 2 5/8 | 2 7/8 | 1/2 | 1 1/2 | 2 1/4 | 3 7/16 | 7 11/16 | |
| | 3 1/2 | 3 1/4-12 | 2 1/2-12 | 3 1/2 | 4.249 | 1 | 3 | 3 3/8 | 1/2 | 1 1/2 | 2 1/4 | 3 7/16 | 7 11/16 | |

Miller AV Series Heavy-Duty Air Cylinders

Cap Rectangular Flange Mount
1" to 6" Bore Sizes

Cap Rectangular Flange Mount

Model 62

1" - 1 1/2" - 2" - 2 1/2" - 5" and 6" Bore

With Maximum Oversize Rods

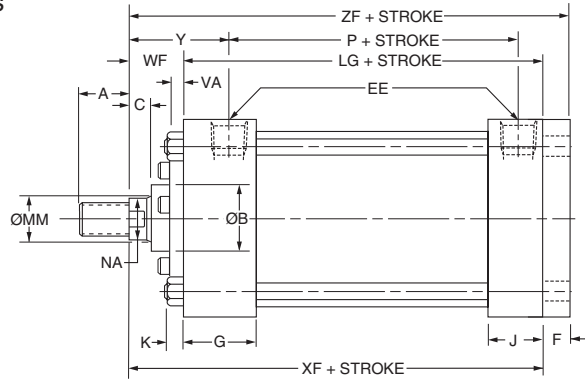
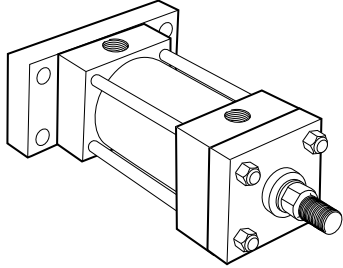

Retainer Held Bushing

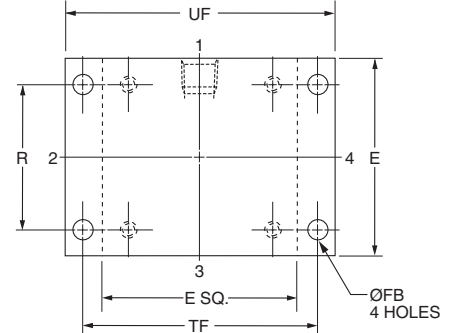

Before determining dimensions: See chart on page 3 for cylinder rod combinations that have removable bushings.

Cap Rectangular Flange Mount

Model 62

1 1/2" - 6" Bore

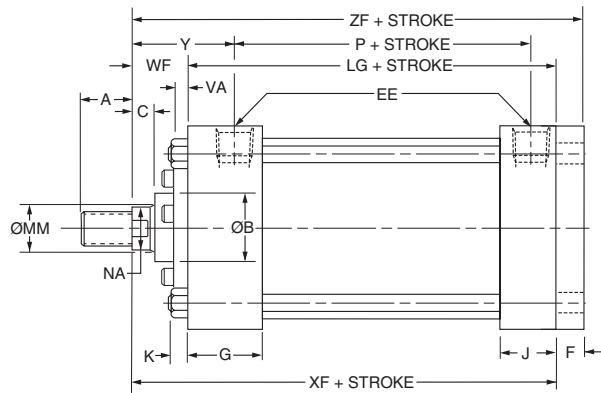
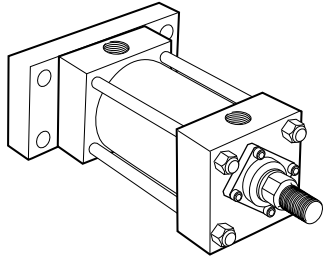

Bolted Bushing

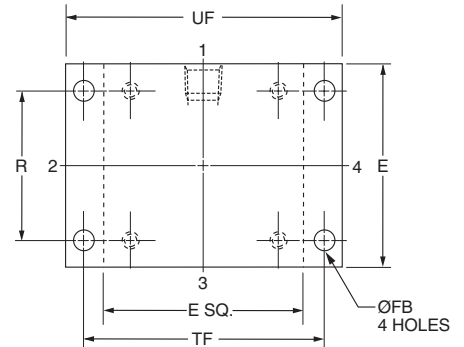

Rod End Dimensions — see table 2

Thread Style 2

Small Male

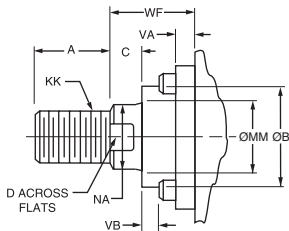

Thread Style 4

Short Female

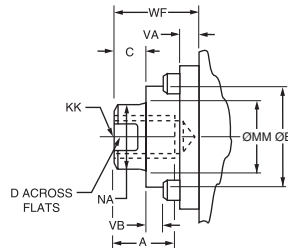

Thread Style 5

Intermediate Male

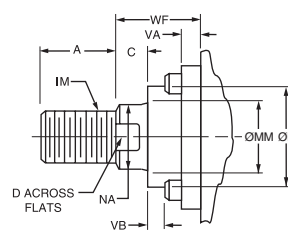

“Special” Thread Style X

Special thread, extension, rod eye, blank, etc., are also available.

To order, specify “Style X” and give desired dimensions for KK, A, W or WF. If otherwise special, furnish dimensioned sketch.

A high strength rod end stud is supplied on thread style 2 through 2" diameter rods and on thread style 5 through 1 3/8" diameter rods. Larger sizes or special rod ends are cut threads. Style 2 rod ends are recommended where the workpiece is secured against the rod shoulder. When the workpiece is not shouldered, style 2 rod ends

are recommended through 2" piston rod diameters and style 5 rod ends are recommended on larger diameters. Use style 4 for applications where female rod end threads are required. If rod end is not specified, style 2 will be supplied.

Miller AV Series Heavy-Duty Air Cylinders

Cap Rectangular Flange Mount
1" to 6" Bore Sizes

Table 1—Envelope and Mounting Dimensions

| Bore | E | EE NPTF | F | FB* (Bolt) | G | J | K | R | TF | UF | Add Stroke | | |
|-------|-------|------------|-----|---------------|-------|-------|------|------|---------|-------|------------|-------|-------|
| | | | | | | | | | | | LB | LG | P |
| 1 | ■ | 1/4 | 3/8 | #10 | 1 1/2 | 1 | 3/16 | 1.08 | 2 | 2 1/2 | 3 7/8 | — | 2 1/8 |
| 1 1/2 | 2 | 3/8† | 3/8 | 1/4 | 1 1/2 | 1 | 1/4 | 1.43 | 2 3/4 | 3 3/8 | 4 | 3 5/8 | 2 1/4 |
| 2 | 2 1/2 | 3/8† | 3/8 | 5/16 | 1 1/2 | 1 | 5/16 | 1.84 | 3 3/8 | 4 1/8 | 4 | 3 5/8 | 2 1/4 |
| 2 1/2 | 3 | 3/8† | 3/8 | 5/16 | 1 1/2 | 1 | 5/16 | 2.19 | 3 7/8 | 4 5/8 | 4 1/8 | 3 3/4 | 2 3/8 |
| 3 1/4 | 3 3/4 | 1/2 | 5/8 | 3/8 | 1 3/4 | 1 1/4 | 3/8 | 2.76 | 4 11/16 | 5 1/2 | — | 4 1/4 | 2 5/8 |
| 4 | 4 1/2 | 1/2 | 5/8 | 3/8 | 1 3/4 | 1 1/4 | 3/8 | 3.32 | 5 7/16 | 6 1/4 | — | 4 1/4 | 2 5/8 |
| 5 | 5 1/2 | 1/2 | 5/8 | 1/2 | 1 3/4 | 1 1/4 | 7/16 | 4.10 | 6 5/8 | 7 5/8 | 5 1/8 | 4 1/2 | 2 7/8 |
| 6 | 6 1/2 | 3/4 | 3/4 | 1/2 | 2 | 1 1/2 | 7/16 | 4.88 | 7 5/8 | 8 5/8 | 5 3/4 | 5 | 3 1/8 |

† On 1 1/2", 2" and 2 1/2" bore sizes, the head-end (only) pipe thread is not full depth on cylinders with maximum oversize rods. Minimum of three full threads available.

■ 1" bore head is 1 3/4" x 1 1/2".

*Mounting holes are 1/16" larger than bolt size listed.

Table 2—Rod Dimensions and Envelope Dimensions Affected by Rod Size

| Bore | MM Rod Ø | Thread | | Rod Extensions and Envelope Dimensions Affected By Rod Size | | | | | | | | | | | Add Stroke | |
|-------|----------------|------------------|----------------------|---|-------------------------|-----|---------|---------|-----|-----|--------|-------|-------|---------|------------|-------|
| | | Style 5 IM | Style 2 & 4 KK | A | B Ø +0.002 -0.002 | C | D | NA | V | VA | VB | W | WF | Y | XF | ZF |
| | | | | | | | | | | | | | | | | |
| 1 | 1/2 | 7/16-20 | 5/16-24 | 5/8 | .999 | 3/8 | 3/8 | 7/16 | 1/4 | — | — | 5/8 | — | 1 15/16 | 4 1/2 | 4 7/8 |
| | 5/8 | 1/2-20 | 7/16-20 | 3/4 | 1.124 | 3/8 | 1/2 | 9/16 | 1/4 | — | — | 5/8 | — | 1 15/16 | 4 1/2 | 4 7/8 |
| 1 1/2 | 5/8 | 1/2-20 | 7/16-20 | 3/4 | 1.124 | 3/8 | 1/2 | 9/16 | — | 1/4 | 3/16 | — | 1 | 1 15/16 | 4 5/8 | 5 |
| | 1 | 7/8-14 | 3/4-16 | 1 1/8 | 1.499 | 1/2 | 7/8 | 1 5/16 | 1/2 | — | — | 1 | — | 2 5/16 | 5 | 5 3/8 |
| 2 | 5/8 | 1/2-20 | 7/16-20 | 3/4 | 1.124 | 3/8 | 1/2 | 9/16 | — | 1/4 | 3/16 | — | 1 | 1 15/16 | 4 5/8 | 5 |
| | 1 3/8 | 1 1/4-12 | 1-14 | 1 5/8 | 1.999 | 5/8 | 1 1/8 | 1 5/16 | 5/8 | — | — | 1 1/4 | — | 2 9/16 | 5 1/4 | 5 5/8 |
| 2 1/2 | 1 | 7/8-14 | 3/4-16 | 1 1/8 | 1.499 | 1/2 | 7/8 | 1 5/16 | — | 1/4 | 3/8 | — | 1 3/8 | 2 5/16 | 5 | 5 3/8 |
| | 5/8 | 1/2-20 | 7/16-20 | 3/4 | 1.124 | 3/8 | 1/2 | 9/16 | — | 1/4 | 3/16 | — | 1 | 1 15/16 | 4 3/4 | 5 1/8 |
| 3 1/4 | 1 3/4 | 1 1/2-12 | 1 1/4-12 | 2 | 2.374 | 3/4 | 1 1/2 | 1 11/16 | 3/4 | — | — | 1 1/2 | — | 2 13/16 | 5 5/8 | 6 |
| | 1 | 7/8-14 | 3/4-16 | 1 1/8 | 1.499 | 1/2 | 7/8 | 1 5/16 | — | 1/4 | 3/8 | — | 1 3/8 | 2 7/16 | 5 5/8 | 6 1/4 |
| 4 | 2 | 1 3/4-12 | 1 1/2-12 | 2 1/4 | 2.624 | 7/8 | 1 11/16 | 1 15/16 | — | 1/4 | 9/16 | — | 2 | 3 1/16 | 6 1/4 | 6 7/8 |
| | 1 3/8 | 1 1/4-12 | 1-14 | 1 5/8 | 1.999 | 5/8 | 1 1/8 | 1 5/16 | — | 1/4 | 1/2 | — | 1 5/8 | 2 11/16 | 5 7/8 | 6 1/2 |
| 5 | 1 3/4 | 1 1/2-12 | 1 1/4-12 | 2 | 2.374 | 3/4 | 1 1/2 | 1 11/16 | — | 1/4 | 9/16 | — | 1 7/8 | 2 15/16 | 6 1/8 | 6 3/4 |
| | 1 | 7/8-14 | 3/4-16 | 1 1/8 | 1.499 | 1/2 | 7/8 | 1 5/16 | — | 1/4 | 3/8 | — | 1 3/8 | 2 7/16 | 5 5/8 | 6 1/4 |
| 6 | 2 1/2 | 2 1/4-12 | 1 7/8-12 | 3 | 3.124 | 1 | 2 1/16 | 2 3/8 | — | 1/4 | 1 1/16 | — | 2 1/4 | 3 5/16 | 6 1/2 | 7 1/8 |
| | 1 3/8 | 1 1/4-12 | 1-14 | 1 5/8 | 1.999 | 5/8 | 1 1/8 | 1 5/16 | — | 1/4 | 1/2 | — | 1 5/8 | 2 11/16 | 6 1/8 | 6 3/4 |
| 7 | 1 3/4 | 1 1/2-12 | 1 1/4-12 | 2 | 2.374 | 3/4 | 1 1/2 | 1 11/16 | — | 1/4 | 9/16 | — | 1 7/8 | 2 15/16 | 6 3/8 | 7 |
| | 2 | 1 3/4-12 | 1 1/2-12 | 2 1/4 | 2.624 | 7/8 | 1 11/16 | 1 15/16 | — | 1/4 | 9/16 | — | 2 | 3 1/16 | 6 1/2 | 7 1/8 |
| 8 | 2 1/2 | 2 1/4-12 | 1 7/8-12 | 3 | 3.124 | 1 | 2 1/16 | 2 3/8 | — | 1/4 | 1 1/16 | — | 2 1/4 | 3 5/16 | 6 3/4 | 7 3/8 |
| | 3 | 2 3/4-12 | 2 1/4-12 | 3 1/2 | 3.749 | 1 | 2 5/8 | 2 7/8 | 5/8 | — | — | 1 5/8 | — | 3 5/16 | 6 3/4 | 7 3/8 |
| 9 | 1 3/8 | 1 1/4-12 | 1-14 | 1 5/8 | 1.999 | 5/8 | 1 1/8 | 1 5/16 | — | 1/4 | 7/16 | — | 1 5/8 | 2 13/16 | 6 5/8 | 7 3/8 |
| | 4 | 3 3/4-12 | 3-12 | 4 | 4.749 | 1 | 3 3/8 | 3 7/8 | 1/2 | — | — | 1 1/2 | — | 3 7/16 | 7 1/4 | 8 |
| 10 | 1 3/4 | 1 1/2-12 | 1 1/4-12 | 2 | 2.374 | 3/4 | 1 1/2 | 1 11/16 | — | 1/4 | 9/16 | — | 1 7/8 | 2 15/16 | 6 7/8 | 7 5/8 |
| | 2 | 1 3/4-12 | 1 1/2-12 | 2 1/4 | 2.624 | 7/8 | 1 11/16 | 1 15/16 | — | 1/4 | 9/16 | — | 2 | 3 1/16 | 7 | 7 3/4 |
| 11 | 2 1/2 | 2 1/4-12 | 1 7/8-12 | 3 | 3.124 | 1 | 2 1/16 | 2 3/8 | — | 1/4 | 1 1/16 | — | 2 1/4 | 3 7/16 | 7 1/4 | 8 |
| | 3 | 2 3/4-12 | 2 1/4-12 | 3 1/2 | 3.749 | 1 | 2 5/8 | 2 7/8 | 1/2 | — | — | 1 1/2 | — | 3 7/16 | 7 1/4 | 8 |
| 12 | 3 1/2 | 3 1/4-12 | 2 1/2-12 | 3 1/2 | 4.249 | 1 | 3 | 3 3/8 | 1/2 | — | — | 1 1/2 | — | 3 7/16 | 7 1/4 | 8 |

Miller AV Series Heavy-Duty Air Cylinders

Head Square Flange Mount
Cap Square Flange Mount
1" to 6" Bore Sizes

Head Square Flange Mount Model 65 1" - 6" Bore

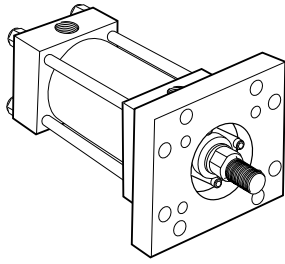

Bolted Bushing

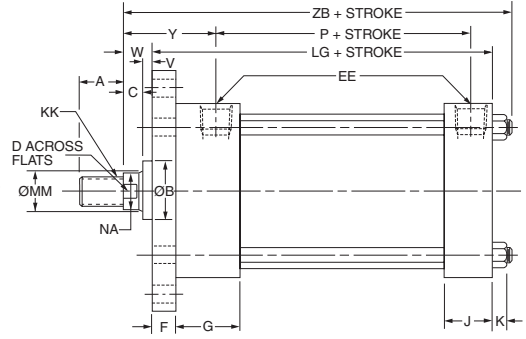
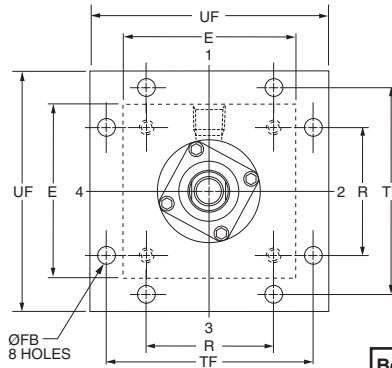

Before determining dimensions: See chart on page 3 for cylinder rod combinations that have removable bushings.

Cap Square Flange Mount Model 66 1" - 1 1/2" - 2" - 2 1/2" - 5" and 6" Bore With Maximum Oversize Rods

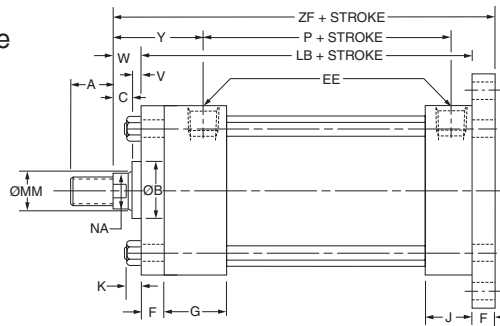
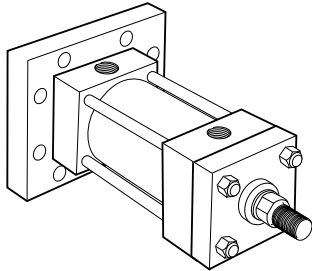

Retainer Held Bushing

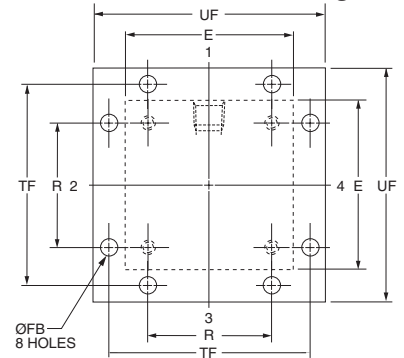

Cap Square Flange Mount Model 66 1 1/2" - 6" Bore

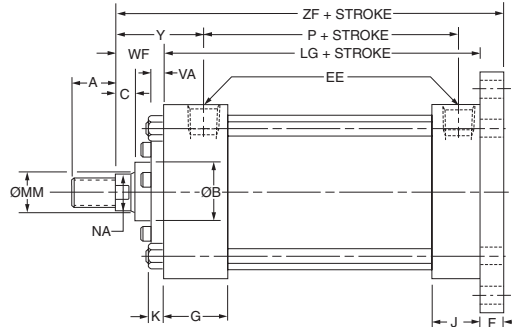
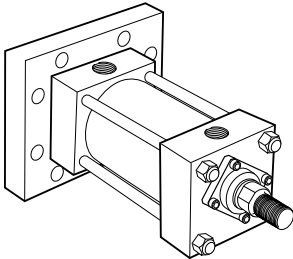

Bolted Bushing

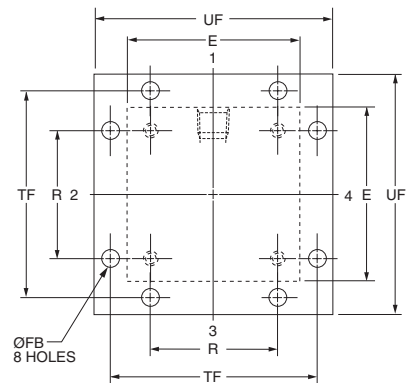

Rod End Dimensions — see table 2

Thread Style 2 Small Male

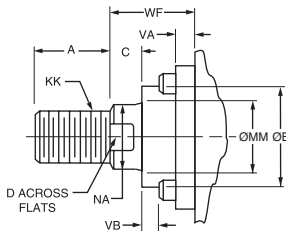

Thread Style 4 Short Female

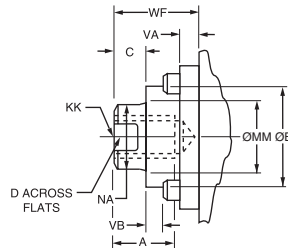

Thread Style 5 Intermediate Male

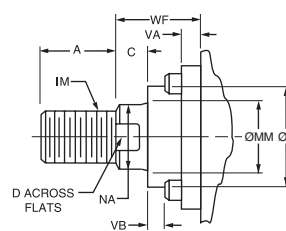

"Special" Thread Style X

Special thread, extension, rod eye, blank, etc., are also available.

To order, specify "Style X" and give desired dimensions for KK, A, W or WF. If otherwise special, furnish dimensioned sketch.

A high strength rod end stud is supplied on thread style 2 through 2" diameter rods and on thread style 5 through 1 3/8" diameter rods. Larger sizes or special rod ends are cut threads. Style 2 rod ends are recommended where the workpiece is secured against the rod shoulder. When the workpiece is not shouldered, style 2 rod ends

are recommended through 2" piston rod diameters and style 5 rod ends are recommended on larger diameters. Use style 4 for applications where female rod end threads are required. If rod end is not specified, style 2 will be supplied.

Miller AV Series Heavy-Duty Air Cylinders

Head Square Flange Mount
Cap Square Flange Mount
1" to 6" Bore Sizes

Table 1—Envelope and Mounting Dimensions

| Bore | E | EE NPTF | F | FB* (Bolt) | G | J | K | R | TF | UF | Add Stroke | | |
|-------|-------|------------|-----|---------------|-------|-------|------|------|---------|-------|------------|-------|-------|
| | | | | | | | | | | | LB | LG | P |
| 1 | ■ | 1/4 | 3/8 | #10 | 1 1/2 | 1 | 3/16 | 1.08 | 2 | 2 1/2 | 3 7/8 | — | 2 1/8 |
| 1 1/2 | 2 | 3/8† | 3/8 | 1/4 | 1 1/2 | 1 | 1/4 | 1.43 | 2 3/4 | 3 3/8 | 4 | 3 5/8 | 2 1/4 |
| 2 | 2 1/2 | 3/8† | 3/8 | 5/16 | 1 1/2 | 1 | 5/16 | 1.84 | 3 3/8 | 4 1/8 | 4 | 3 5/8 | 2 1/4 |
| 2 1/2 | 3 | 3/8† | 3/8 | 5/16 | 1 1/2 | 1 | 5/16 | 2.19 | 3 7/8 | 4 5/8 | 4 1/8 | 3 3/4 | 2 3/8 |
| 3 1/4 | 3 3/4 | 1/2 | 5/8 | 3/8 | 1 3/4 | 1 1/4 | 3/8 | 2.76 | 4 11/16 | 5 1/2 | 4 7/8 | 4 1/4 | 2 5/8 |
| 4 | 4 1/2 | 1/2 | 5/8 | 3/8 | 1 3/4 | 1 1/4 | 3/8 | 3.32 | 5 7/16 | 6 1/4 | 4 7/8 | 4 1/4 | 2 5/8 |
| 5 | 5 1/2 | 1/2 | 5/8 | 1/2 | 1 3/4 | 1 1/4 | 7/16 | 4.10 | 6 5/8 | 7 5/8 | 5 1/8 | 4 1/2 | 2 7/8 |
| 6 | 6 1/2 | 3/4 | 3/4 | 1/2 | 2 | 1 1/2 | 7/16 | 4.88 | 7 5/8 | 8 5/8 | 5 3/4 | 5 | 3 1/8 |

† On 1 1/2", 2" and 2 1/2" bore sizes, the head-end (only) pipe thread is not full depth on cylinders with maximum oversize rods. Minimum of three full threads available.

■ 1" bore head is 1 3/4" x 1 1/2".

*Mounting holes are 1/16" larger than bolt size listed.

Table 2—Rod End Dimensions and Envelope Dimensions Affected By Rod Size

| Bore | MM Rod Ø | Thread | | Rod Extensions and Envelope Dimensions Affected By Rod Size | | | | | | | | | | | Add Stroke | |
|-------|----------------|------------------|----------------------|---|-------------------------|-----|---------|---------|------|-----|--------|-------|---------|---------|------------|-------|
| | | Style 5 IM | Style 2 & 4 KK | A | B Ø +0.000 -0.002 | C | D | NA | V | VA | VB | W | WF | Y | ZB | ZF |
| | | | | | | | | | | | | | | | | |
| 1 | 1/2 | 7/16-20 | 5/16-24 | 5/8 | .999 | 3/8 | 3/8 | 7/16 | 1/4 | — | — | 5/8 | — | 1 5/16 | 4 11/16 | 4 7/8 |
| | 5/8 | 1/2-20 | 7/16-20 | 3/4 | 1.124 | 3/8 | 1/2 | 9/16 | 1/4 | — | — | 5/8 | — | 1 5/16 | 4 11/16 | 4 7/8 |
| 1 1/2 | 5/8 | 1/2-20 | 7/16-20 | 3/4 | 1.124 | 3/8 | 1/2 | 9/16 | 1/4* | 1/4 | 3/16 | 1 | 1 5/16 | 4 7/8 | 5 | |
| | 1 | 7/8-14 | 3/4-16 | 1 1/8 | 1.499 | 1/2 | 7/8 | 1 5/16 | 1/2 | — | — | 1 | — | 2 5/16 | 5 1/4 | 5 3/8 |
| 2 | 5/8 | 1/2-20 | 7/16-20 | 3/4 | 1.124 | 3/8 | 1/2 | 9/16 | 1/4* | 1/4 | 3/16 | 5/8 | 1 | 1 5/16 | 4 5/16 | 5 |
| | 1 3/8 | 1 1/4-12 | 1-14 | 1 5/8 | 1.999 | 5/8 | 1 1/8 | 1 5/16 | 5/8 | — | — | 1 1/4 | — | 2 9/16 | 5 9/16 | 5 5/8 |
| 2 1/2 | 1 | 7/8-14 | 3/4-16 | 1 1/8 | 1.499 | 1/2 | 7/8 | 1 5/16 | 1/2* | 1/4 | 3/8 | 1 | 1 3/8 | 2 5/16 | 5 5/16 | 5 3/8 |
| | 5/8 | 1/2-20 | 7/16-20 | 3/4 | 1.124 | 3/8 | 1/2 | 9/16 | 1/4* | 1/4 | 3/16 | 5/8 | 1 | 1 5/16 | 5 1/16 | 5 1/8 |
| 3 1/4 | 1 3/4 | 1 1/2-12 | 1 1/4-12 | 2 | 2.374 | 3/4 | 1 1/2 | 1 11/16 | 3/4 | — | — | 1 1/2 | — | 2 13/16 | 5 5/16 | 6 |
| | 1 | 7/8-14 | 3/4-16 | 1 1/8 | 1.499 | 1/2 | 7/8 | 1 5/16 | 1/2* | 1/4 | 3/8 | 1 | 1 3/8 | 2 5/16 | 5 7/16 | 5 1/2 |
| 4 | 1 3/8 | 1 1/4-12 | 1-14 | 1 5/8 | 1.999 | 5/8 | 1 1/8 | 1 5/16 | 5/8 | — | — | 1 1/4 | — | 2 9/16 | 5 11/16 | 5 3/4 |
| | 1 | 7/8-14 | 3/4-16 | 1 1/8 | 1.499 | 1/2 | 7/8 | 1 5/16 | 1/4* | 1/4 | 3/8 | 3/4 | 1 3/8 | 2 7/16 | 6 | 6 1/4 |
| 5 | 2 1/2 | 2 1/4-12 | 1 7/8-12 | 3 | 3.124 | 1 | 2 1/16 | 2 9/8 | 5/8* | 1/4 | 1 1/16 | 1 5/8 | 2 1/4 | 3 5/16 | 6 7/8 | 7 1/8 |
| | 1 3/8 | 1 1/4-12 | 1-14 | 1 5/8 | 1.999 | 5/8 | 1 1/8 | 1 5/16 | 3/8* | 1/4 | 1/2 | 1 | 1 5/8 | 2 11/16 | 6 3/16 | 6 3/4 |
| 6 | 1 3/4 | 1 1/2-12 | 1 1/4-12 | 2 | 2.374 | 3/4 | 1 1/2 | 1 11/16 | 1/2* | 1/4 | 9/16 | 1 1/4 | 1 7/8 | 2 15/16 | 6 1/2 | 6 3/4 |
| | 2 | 1 3/4-12 | 1 1/2-12 | 2 1/4 | 2.624 | 7/8 | 1 11/16 | 1 15/16 | 1/2* | 1/4 | 9/16 | 1 3/8 | 2 | 3 1/16 | 6 5/8 | 6 7/8 |
| 7 | 2 1/2 | 2 1/4-12 | 1 7/8-12 | 3 | 3.124 | 1 | 2 1/16 | 2 9/8 | 5/8* | 1/4 | 1 1/16 | 1 5/8 | 2 1/4 | 3 5/16 | 7 3/16 | 7 3/8 |
| | 3 | 2 3/4-12 | 2 1/4-12 | 3 1/2 | 3.749 | 1 | 2 5/8 | 2 7/8 | 5/8 | — | — | 1 5/8 | — | 3 5/16 | 7 3/16 | 7 3/8 |
| 8 | 1 3/8 | 1 1/4-12 | 1-14 | 1 5/8 | 1.999 | 5/8 | 1 1/8 | 1 5/16 | 1/4 | 1/4 | 7/16 | 1 5/8 | 2 13/16 | 7 1/16 | 7 3/8 | |
| | 4 | 3 3/4-12 | 3-12 | 4 | 4.749 | 1 | 3 3/8 | 3 7/8 | 3/8 | — | — | 1 1/2 | — | 3 7/16 | 7 11/16 | 8 |
| 9 | 1 3/4 | 1 1/2-12 | 1 1/4-12 | 2 | 2.374 | 3/4 | 1 1/2 | 1 11/16 | 3/8* | 1/4 | 9/16 | 1 1/8 | 1 7/8 | 3 1/16 | 7 5/16 | 7 5/8 |
| | 2 | 1 3/4-12 | 1 1/2-12 | 2 1/4 | 2.624 | 7/8 | 1 11/16 | 1 15/16 | 1/2* | 1/4 | 9/16 | 1 1/4 | 2 | 3 3/16 | 7 7/16 | 7 3/4 |
| 10 | 2 1/2 | 2 1/4-12 | 1 7/8-12 | 3 | 3.124 | 1 | 2 1/16 | 2 9/8 | 1/2* | 1/4 | 1 1/16 | 1 1/2 | 2 1/4 | 3 7/16 | 7 11/16 | 8 |
| | 3 | 2 3/4-12 | 2 1/4-12 | 3 1/2 | 3.749 | 1 | 2 5/8 | 2 7/8 | 1/2 | — | — | 1 1/2 | — | 3 7/16 | 7 11/16 | 8 |
| 11 | 3 1/2 | 3 1/4-12 | 2 1/2-12 | 3 1/2 | 4.249 | 1 | 3 | 3 3/8 | 1/2 | — | — | 1 1/2 | — | 3 7/16 | 7 11/16 | 8 |

* For all Model 65 and Model 66 mounts with maximum oversized rods.

Miller AV Series Heavy-Duty Air Cylinders

Tie Rods Extended Mountings
1" to 6" Bore Sizes

Tie Rods Extended Both Ends Mount

Model 51

1" - 1 1/2" - 2" - 2 1/2" - 5" and 6" Bore

With Maximum Oversize Rods

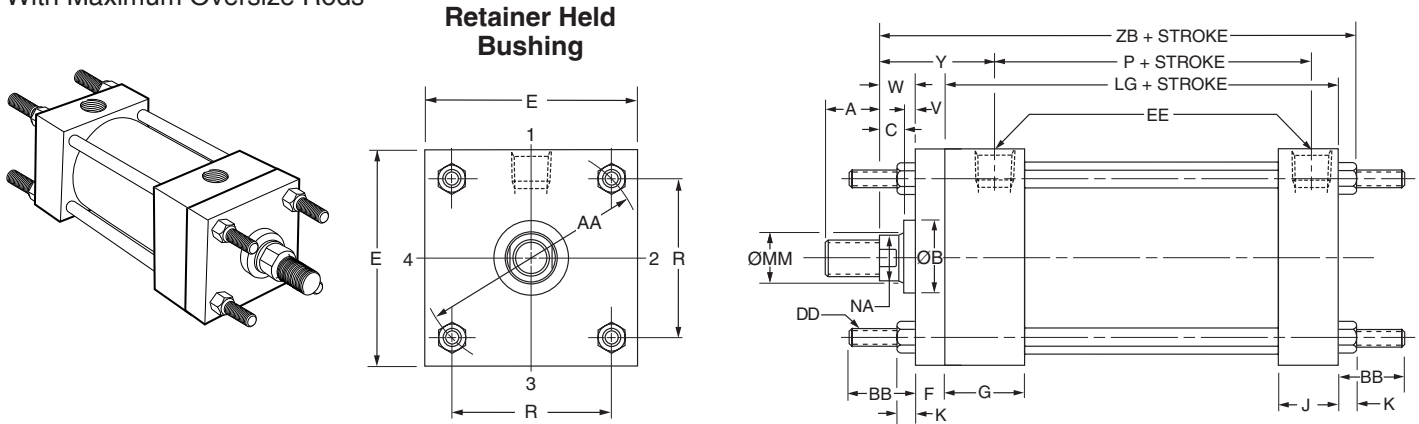

Tie Rods can be extended: Both Ends — Model 51; Cap End — Model 52; Head End — Model 53. All Tie Rod Models can be dimensioned from Model 51 drawings shown.

Before determining dimensions: See chart on page 3 for cylinder rod combinations that have removable bushings.

Tie Rods Extended Both Ends Mount

Model 51

1 1/2" - 6" Bore

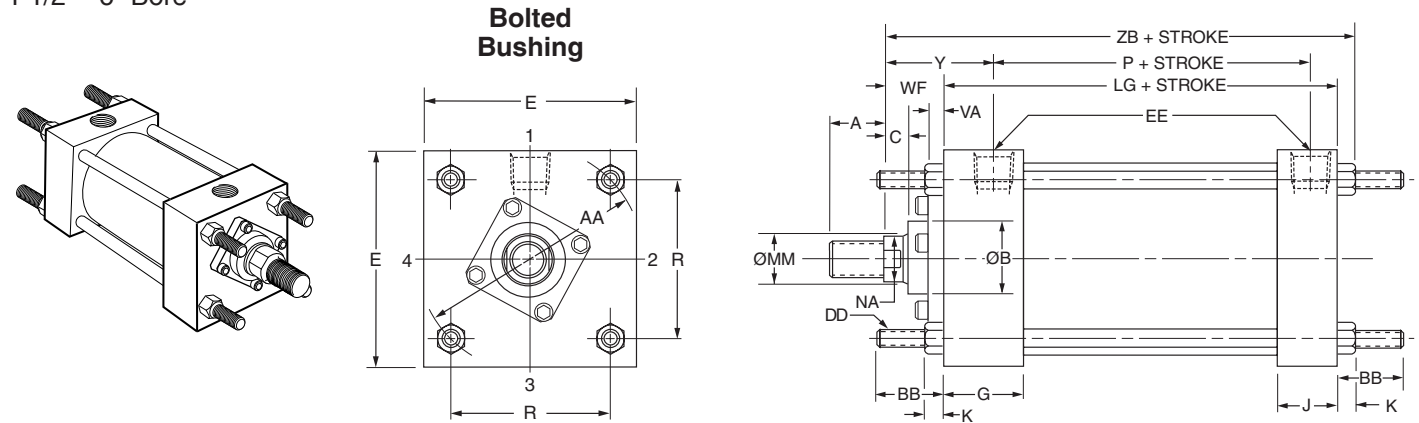

Rod End Dimensions — see table 2

Thread Style 2

Small Male

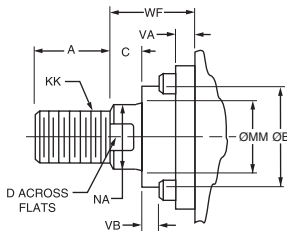

A high strength rod end stud is supplied on thread style 2 through 2" diameter rods and on thread style 5 through 1 3/8" diameter rods. Larger sizes or special rod ends are cut threads. Style 2 rod ends are recommended where the workpiece is secured against the rod shoulder. When the workpiece is not shouldered, style 2 rod ends

Thread Style 4

Short Female

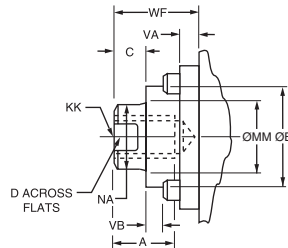

are recommended through 2" piston rod diameters and style 5 rod ends are recommended on larger diameters. Use style 4 for applications where female rod end threads are required. If rod end is not specified, style 2 will be supplied.

Thread Style 5

Intermediate Male

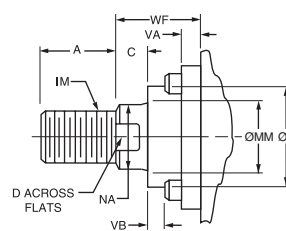

"Special" Thread Style X

Special thread, extension, rod eye, blank, etc., are also available.

To order, specify "Style X" and give desired dimensions for KK, A, W or WF. If otherwise special, furnish dimensioned sketch.

Miller AV Series Heavy-Duty Air Cylinders

Tie Rods Extended Mountings
1" to 6" Bore Sizes

Table 1—Envelope and Mounting Dimensions

| Bore | AA | BB | DD | E | EE NPTF | F | G | J | K | R | Add Stroke | |
|-------|------|---------|---------|-------|------------|-----|-------|-------|------|------|------------|-------|
| | | | | | | | | | | | LG | P |
| 1 | 1.53 | 3/4 | 10-24 | ■ | 1/4 | 3/8 | 1 1/2 | 1 | 3/16 | 1.08 | 3 1/2 | 2 1/8 |
| 1 1/2 | 2.02 | 1 | 1/4-28 | 2 | 3/8† | 3/8 | 1 1/2 | 1 | 1/4 | 1.43 | 3 5/8 | 2 1/4 |
| 2 | 2.6 | 1 1/8 | 5/16-24 | 2 1/2 | 3/8† | 3/8 | 1 1/2 | 1 | 5/16 | 1.84 | 3 5/8 | 2 1/4 |
| 2 1/2 | 3.1 | 1 1/8 | 5/16-24 | 3 | 3/8† | 3/8 | 1 1/2 | 1 | 5/16 | 2.19 | 3 3/4 | 2 3/8 |
| 3 1/4 | 3.9 | 1 3/8 | 3/8-24 | 3 3/4 | 1/2 | — | 1 3/4 | 1 1/4 | 3/8 | 2.76 | 4 1/4 | 2 5/8 |
| 4 | 4.7 | 1 3/8 | 3/8-24 | 4 1/2 | 1/2 | — | 1 3/4 | 1 1/4 | 3/8 | 3.32 | 4 1/4 | 2 5/8 |
| 5 | 5.8 | 1 13/16 | 1/2-20 | 5 1/2 | 1/2 | 5/8 | 1 3/4 | 1 1/4 | 7/16 | 4.10 | 4 1/2 | 2 7/8 |
| 6 | 6.9 | 1 13/16 | 1/2-20 | 6 1/2 | 3/4 | 3/4 | 2 | 1 1/2 | 7/16 | 4.88 | 5 | 3 1/8 |

† On 1 1/2", 2" and 2 1/2" bore sizes, the head-end (only) pipe thread is not full depth on cylinders with maximum oversize rods. Minimum of three full threads available.

■ 1" bore head is 1 3/4" x 1 1/2".

Table 2—Rod End Dimensions and Envelope Dimensions Affected By Rod Size

| Bore | MM Rod Ø | Thread | | Rod Extensions and Envelope Dimensions Affected By Rod Size | | | | | | | | | | | | | Add Stroke |
|-------|----------|------------|----------------|---|-------------------------|-------|-----|---------|---------|-----|-----|--------|-------|-------|---------|---------|------------|
| | | Style 5 IM | Style 2 & 4 KK | A | B Ø + .000 - .002 | BF | C | D | NA | V | VA | VB | W | WF | Y | | |
| | | ZB | | | | | | | | | | | | | | | |
| 1 | 1/2 | 7/16-20 | 5/16-24 | 5/8 | .999 | — | 3/8 | 3/8 | 7/16 | 1/4 | — | — | 5/8 | — | 1 5/16 | 4 11/16 | |
| | 5/8 | 1/2-20 | 7/16-20 | 3/4 | 1.124 | — | 3/8 | 1/2 | 9/16 | 1/4 | — | — | 5/8 | — | 1 5/16 | 4 11/16 | |
| 1 1/2 | 5/8 | 1/2-20 | 7/16-20 | 3/4 | 1.124 | 1.968 | 3/8 | 1/2 | 9/16 | — | 1/4 | 3/16 | — | 1 | 1 5/16 | 4 7/8 | |
| | 1 | 7/8-14 | 3/4-16 | 1 1/8 | 1.499 | — | 1/2 | 7/8 | 1 5/16 | 1/2 | — | — | 1 | — | 2 5/16 | 5 1/4 | |
| 2 | 5/8 | 1/2-20 | 7/16-20 | 3/4 | 1.124 | 1.968 | 3/8 | 1/2 | 9/16 | — | 1/4 | 3/16 | — | 1 | 1 5/16 | 4 5/16 | |
| | 1 3/8 | 1 1/4-12 | 1-14 | 1 5/8 | 1.999 | — | 5/8 | 1 1/8 | 1 5/16 | 5/8 | — | — | 1 1/4 | — | 2 9/16 | 5 9/16 | |
| 2 1/2 | 1 | 7/8-14 | 3/4-16 | 1 1/8 | 1.499 | 2.468 | 1/2 | 7/8 | 1 5/16 | — | 1/4 | 3/8 | — | 1 3/8 | 2 5/16 | 5 5/16 | |
| | 1 3/8 | 1 1/4-12 | 1-14 | 1 5/8 | 1.999 | 2.968 | 5/8 | 1 1/8 | 1 5/16 | 5/8 | — | — | 1 1/4 | — | 2 9/16 | 5 1/16 | |
| 3 1/4 | 1 | 7/8-14 | 3/4-16 | 1 1/8 | 1.499 | 2.968 | 1/2 | 7/8 | 1 5/16 | — | 1/4 | 3/8 | — | 1 3/8 | 2 7/16 | 6 | |
| | 2 | 1 3/4-12 | 1 1/2-12 | 2 1/4 | 2.624 | 3.735 | 7/8 | 1 11/16 | 1 5/16 | — | 1/4 | 9/16 | — | 2 | 3 1/16 | 6 5/8 | |
| 4 | 1 3/8 | 1 1/4-12 | 1-14 | 1 5/8 | 1.999 | 2.968 | 5/8 | 1 1/8 | 1 5/16 | — | 1/4 | 1/2 | — | 1 5/8 | 2 11/16 | 6 1/4 | |
| | 1 3/4 | 1 1/2-12 | 1 1/4-12 | 2 | 2.374 | 3.735 | 3/4 | 1 1/2 | 1 11/16 | — | 1/4 | 9/16 | — | 1 7/8 | 2 5/16 | 6 1/2 | |
| 5 | 2 | 1 3/4-12 | 1 1/2-12 | 2 1/4 | 2.624 | 3.735 | 7/8 | 1 11/16 | 1 5/16 | — | 1/4 | 9/16 | — | 2 | 3 1/16 | 6 5/8 | |
| | 1 | 7/8-14 | 3/4-16 | 1 1/8 | 1.499 | 2.968 | 1/2 | 7/8 | 1 5/16 | — | 1/4 | 3/8 | — | 1 3/8 | 2 7/16 | 6 5/16 | |
| 6 | 3 1/2 | 3 1/4-12 | 2 1/2-12 | 3 1/2 | 4.249 | 5.562 | 1 | 3 | 3 3/8 | 5/8 | — | — | 1 5/8 | — | 3 5/16 | 7 9/16 | |
| | 1 3/8 | 1 1/4-12 | 1-14 | 1 5/8 | 1.999 | 2.968 | 5/8 | 1 1/8 | 1 5/16 | — | 1/4 | 1/2 | — | 1 5/8 | 2 11/16 | 6 1/16 | |
| 7 | 1 3/4 | 1 1/2-12 | 1 1/4-12 | 2 | 2.374 | 3.735 | 3/4 | 1 1/2 | 1 11/16 | — | 1/4 | 9/16 | — | 1 7/8 | 2 5/16 | 6 13/16 | |
| | 2 | 1 3/4-12 | 1 1/2-12 | 2 1/4 | 2.624 | 3.735 | 7/8 | 1 11/16 | 1 5/16 | — | 1/4 | 9/16 | — | 2 | 3 1/16 | 6 5/16 | |
| 8 | 2 1/2 | 2 1/4-12 | 1 7/8-12 | 3 | 3.124 | 5.000 | 1 | 2 1/16 | 2 9/8 | — | 1/4 | 1 1/16 | — | 2 1/4 | 3 5/16 | 7 3/16 | |
| | 3 | 2 3/4-12 | 2 1/4-12 | 3 1/2 | 3.749 | 5.000 | 1 | 2 5/8 | 2 7/8 | 5/8 | — | — | 1 5/8 | — | 3 5/16 | 7 3/16 | |
| 9 | 1 3/8 | 1 1/4-12 | 1-14 | 1 5/8 | 1.999 | 3.625 | 5/8 | 1 1/8 | 1 5/16 | — | 1/4 | 7/16 | — | 1 5/8 | 2 13/16 | 7 1/16 | |
| | 4 | 3 3/4-12 | 3-12 | 4 | 4.749 | 6.062 | 1 | 3 3/8 | 3 7/8 | 1/2 | — | — | 1 1/2 | — | 3 7/16 | 7 11/16 | |
| 10 | 1 3/4 | 1 1/2-12 | 1 1/4-12 | 2 | 2.374 | 3.625 | 3/4 | 1 1/2 | 1 11/16 | — | 1/4 | 9/16 | — | 1 7/8 | 3 1/16 | 7 5/16 | |
| | 2 | 1 3/4-12 | 1 1/2-12 | 2 1/4 | 2.624 | 4.312 | 7/8 | 1 11/16 | 1 5/16 | — | 1/4 | 9/16 | — | 2 | 3 3/16 | 7 7/16 | |
| 11 | 2 1/2 | 2 1/4-12 | 1 7/8-12 | 3 | 3.124 | 4.312 | 1 | 2 1/16 | 2 9/8 | — | 1/4 | 1 1/16 | — | 2 1/4 | 3 7/16 | 7 11/16 | |
| | 3 | 2 3/4-12 | 2 1/4-12 | 3 1/2 | 3.749 | 5.562 | 1 | 2 5/8 | 2 7/8 | 1/2 | — | — | 1 1/2 | — | 3 7/16 | 7 11/16 | |
| 12 | 3 1/2 | 3 1/4-12 | 2 1/2-12 | 3 1/2 | 4.249 | 5.562 | 1 | 3 | 3 3/8 | 1/2 | — | — | 1 1/2 | — | 3 7/16 | 7 11/16 | |

Miller AV Series Heavy-Duty Air Cylinders

Head Trunnion Mount
1" to 6" Bore Sizes

Head Trunnion Mount

Model 81

1" - 1 1/2" - 2" - 2 1/2" - 5" and 6" Bore

With Maximum Oversize Rods

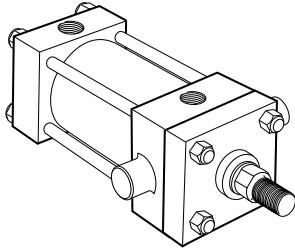

Retainer Held Bushing

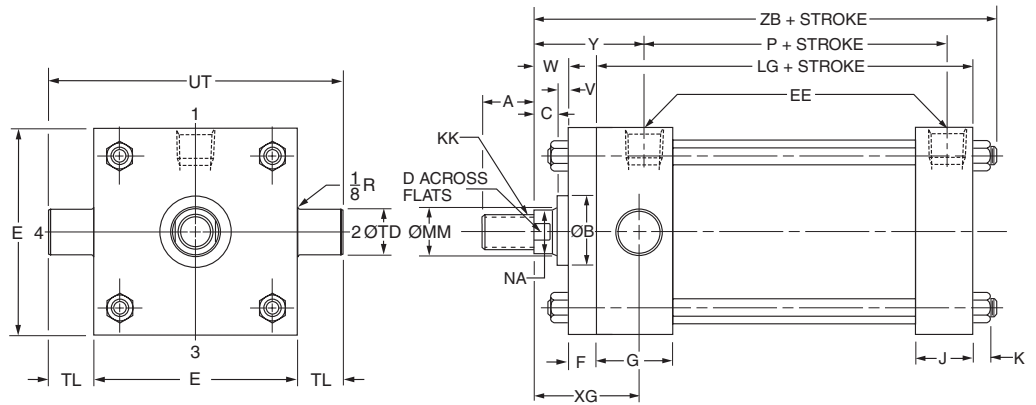

Before determining dimensions: See chart on page 3 for cylinder rod combinations that have removable bushings.

Head Trunnion Mount

Model 81

1 1/2" - 6" Bore

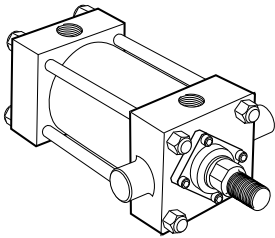

Bolted Bushing

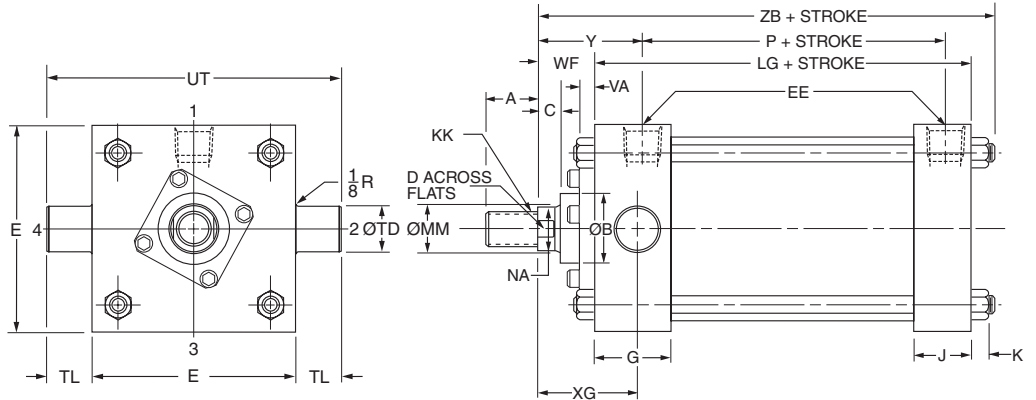

Rod End Dimensions — see table 2

Thread Style 2

Small Male

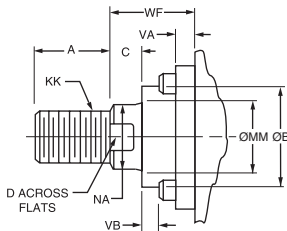

A high strength rod end stud is supplied on thread style 2 through 2" diameter rods and on thread style 5 through 1 3/8" diameter rods. Larger sizes or special rod ends are cut threads. Style 2 rod ends are recommended where the workpiece is secured against the rod shoulder. When the workpiece is not shouldered, style 2 rod ends

Thread Style 4

Short Female

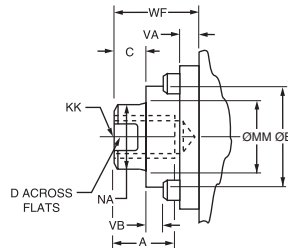

are recommended through 2" piston rod diameters and style 5 rod ends are recommended on larger diameters. Use style 4 for applications where female rod end threads are required. If rod end is not specified, style 2 will be supplied.

Thread Style 5

Intermediate Male

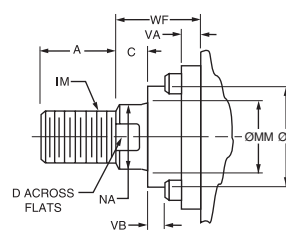

"Special" Thread Style X

Special thread, extension, rod eye, blank, etc., are also available.

To order, specify "Style X" and give desired dimensions for KK, A, W or WF. If otherwise special, furnish dimensioned sketch.

Miller AV Series Heavy-Duty Air Cylinders

Head Trunnion Mount
1" to 6" Bore Sizes

Table 1—Envelope and Mounting Dimensions

| Bore | E | EE NPTF | F | G | J | K | TD Ø +0.000 -0.001 | TL | UT | Add Stroke | |
|-------|-------|------------|-----|-------|-------|------|--------------------------|-------|-------|------------|-------|
| | | | | | | | | | | LG | P |
| 1 | ■ | 1/4 | 3/8 | 1 1/2 | 1 | 3/16 | .750 | 3/4 | 3 | 3 1/2 | 2 1/8 |
| 1 1/2 | 2 | 3/8† | 3/8 | 1 1/2 | 1 | 1/4 | 1.000 | 1 | 4 | 3 5/8 | 2 1/4 |
| 2 | 2 1/2 | 3/8† | 3/8 | 1 1/2 | 1 | 5/16 | 1.000 | 1 | 4 1/2 | 3 5/8 | 2 1/4 |
| 2 1/2 | 3 | 3/8† | 3/8 | 1 1/2 | 1 | 5/16 | 1.000 | 1 | 5 | 3 3/4 | 2 3/8 |
| 3 1/4 | 3 3/4 | 1/2 | — | 1 3/4 | 1 1/4 | 3/8 | 1.000 | 1 | 5 3/4 | 4 1/4 | 2 5/8 |
| 4 | 4 1/2 | 1/2 | — | 1 3/4 | 1 1/4 | 3/8 | 1.000 | 1 | 6 1/2 | 4 1/4 | 2 5/8 |
| 5 | 5 1/2 | 1/2 | 5/8 | 1 3/4 | 1 1/4 | 7/16 | 1.000 | 1 | 7 1/2 | 4 1/2 | 2 7/8 |
| 6 | 6 1/2 | 3/4 | 3/4 | 2 | 1 1/2 | 7/16 | 1.375 | 1 3/8 | 9 1/4 | 5 | 3 1/8 |

† On 1 1/2", 2" and 2 1/2" bore sizes, the head-end (only) pipe thread is not full depth on cylinders with maximum oversize rods. Minimum of three full threads available.

■ 1" bore head is 1 3/4" x 1 1/2".

Table 2—Rod End Dimensions and Envelope Dimensions Affected By Rod Size

| Bore | MM Rod Ø | Thread | | Rod Extensions and Envelope Dimensions Affected By Rod Size | | | | | | | | | | | | | Add Stroke | |
|-------|----------------|------------------|----------------------|---|-------------------------|-----|---------|---------|-----|-----|--------|-------|-------|-------|---------|---------|------------|--|
| | | Style 5 IM | Style 2 & 4 KK | A | B Ø +0.000 -0.002 | C | D | NA | V | VA | VB | W | WF | XG | Y | ZB | | |
| | | | | | | | | | | | | | | | | | | |
| 1 | 1/2 | 7/16-20 | 5/16-24 | 5/8 | .999 | 3/8 | 3/8 | 7/16 | 1/4 | — | — | 5/8 | — | 1 3/4 | 1 15/16 | 4 11/16 | | |
| | 5/8 | 1/2-20 | 7/16-20 | 3/4 | 1.124 | 3/8 | 1/2 | 9/16 | 1/4 | — | — | 5/8 | — | 1 3/4 | 1 15/16 | 4 11/16 | | |
| 1 1/2 | 5/8 | 1/2-20 | 7/16-20 | 3/4 | 1.124 | 3/8 | 1/2 | 9/16 | — | 1/4 | 3/16 | — | 1 | 1 3/4 | 1 15/16 | 4 7/8 | | |
| | 1 | 7/8-14 | 3/4-16 | 1 1/8 | 1.499 | 1/2 | 7/8 | 15/16 | 1/2 | — | — | 1 | — | 2 1/8 | 2 5/16 | 5 1/4 | | |
| 2 | 5/8 | 1/2-20 | 7/16-20 | 3/4 | 1.124 | 3/8 | 1/2 | 9/16 | — | 1/4 | 3/16 | — | 1 | 1 3/4 | 1 15/16 | 4 5/16 | | |
| | 1 3/8 | 1 1/4-12 | 1-14 | 1 5/8 | 1.999 | 5/8 | 1 1/8 | 1 5/16 | 5/8 | — | — | 1 1/4 | — | 2 3/8 | 2 9/16 | 5 9/16 | | |
| 2 1/2 | 1 | 7/8-14 | 3/4-16 | 1 1/8 | 1.499 | 1/2 | 7/8 | 15/16 | — | 1/4 | 3/8 | — | 1 3/8 | 2 1/8 | 2 5/16 | 5 5/16 | | |
| | 5/8 | 1/2-20 | 7/16-20 | 3/4 | 1.124 | 3/8 | 1/2 | 9/16 | — | 1/4 | 3/16 | — | 1 | 1 3/4 | 1 15/16 | 5 1/16 | | |
| 3 1/4 | 1 3/4 | 1 1/2-12 | 1 1/4-12 | 2 | 2.374 | 3/4 | 1 1/2 | 1 11/16 | 3/4 | — | — | 1 1/2 | — | 2 5/8 | 2 13/16 | 5 5/16 | | |
| | 1 | 7/8-14 | 3/4-16 | 1 1/8 | 1.499 | 1/2 | 7/8 | 15/16 | — | 1/4 | 3/8 | — | 1 3/8 | 2 1/4 | 2 7/16 | 6 | | |
| 4 | 2 | 1 3/4-12 | 1 1/2-12 | 2 1/4 | 2.624 | 7/8 | 1 11/16 | 1 15/16 | — | 1/4 | 9/16 | — | 2 | 2 7/8 | 3 1/16 | 6 5/8 | | |
| | 1 3/8 | 1 1/4-12 | 1-14 | 1 5/8 | 1.999 | 5/8 | 1 1/8 | 1 5/16 | — | 1/4 | 1/2 | — | 1 5/8 | 2 1/2 | 2 11/16 | 6 1/4 | | |
| 5 | 1 3/4 | 1 1/2-12 | 1 1/4-12 | 2 | 2.374 | 3/4 | 1 1/2 | 1 11/16 | — | 1/4 | 9/16 | — | 1 7/8 | 2 3/4 | 2 15/16 | 6 13/16 | | |
| | 1 | 7/8-14 | 3/4-16 | 1 1/8 | 1.499 | 1/2 | 7/8 | 15/16 | — | 1/4 | 3/8 | — | 1 3/8 | 2 1/4 | 2 7/16 | 6 5/16 | | |
| 6 | 3 1/2 | 3 1/4-12 | 2 1/2-12 | 3 1/2 | 4.249 | 1 | 3 | 3 3/8 | 5/8 | — | — | 1 5/8 | — | 3 1/8 | 3 5/16 | 7 3/16 | | |
| | 1 3/8 | 1 1/4-12 | 1-14 | 1 5/8 | 1.999 | 5/8 | 1 1/8 | 1 5/16 | — | 1/4 | 1/2 | — | 1 5/8 | 2 1/2 | 2 11/16 | 6 9/16 | | |
| 7 | 1 3/4 | 1 1/2-12 | 1 1/4-12 | 2 | 2.374 | 3/4 | 1 1/2 | 1 11/16 | — | 1/4 | 9/16 | — | 1 7/8 | 2 3/4 | 2 15/16 | 6 13/16 | | |
| | 2 | 1 3/4-12 | 1 1/2-12 | 2 1/4 | 2.624 | 7/8 | 1 11/16 | 1 15/16 | — | 1/4 | 9/16 | — | 2 | 2 7/8 | 3 1/16 | 6 15/16 | | |
| 8 | 2 1/2 | 2 1/4-12 | 1 7/8-12 | 3 | 3.124 | 1 | 2 1/16 | 2 3/8 | — | 1/4 | 1 1/16 | — | 2 1/4 | 3 1/8 | 3 5/16 | 7 3/16 | | |
| | 3 | 2 3/4-12 | 2 1/4-12 | 3 1/2 | 3.749 | 1 | 2 5/8 | 2 7/8 | 5/8 | — | — | 1 5/8 | — | 3 3/8 | 3 5/16 | 7 3/16 | | |
| 9 | 1 3/8 | 1 1/4-12 | 1-14 | 1 5/8 | 1.999 | 5/8 | 1 1/8 | 1 5/16 | — | 1/4 | 7/16 | — | 1 5/8 | 2 5/8 | 2 13/16 | 7 1/16 | | |
| | 4 | 3 3/4-12 | 3-12 | 4 | 4.749 | 1 | 3 3/8 | 3 7/8 | 1/2 | — | — | 1 1/2 | — | 3 1/4 | 3 7/16 | 7 11/16 | | |
| 10 | 1 3/4 | 1 1/2-12 | 1 1/4-12 | 2 | 2.374 | 3/4 | 1 1/2 | 1 11/16 | — | 1/4 | 9/16 | — | 1 7/8 | 2 7/8 | 3 1/16 | 7 5/16 | | |
| | 2 | 1 3/4-12 | 1 1/2-12 | 2 1/4 | 2.624 | 7/8 | 1 11/16 | 1 15/16 | — | 1/4 | 9/16 | — | 2 | 3 | 3 3/16 | 7 7/16 | | |
| 11 | 2 1/2 | 2 1/4-12 | 1 7/8-12 | 3 | 3.124 | 1 | 2 1/16 | 2 3/8 | — | 1/4 | 1 1/16 | — | 2 1/4 | 3 1/4 | 3 7/16 | 7 11/16 | | |
| | 3 | 2 3/4-12 | 2 1/4-12 | 3 1/2 | 3.749 | 1 | 2 5/8 | 2 7/8 | 1/2 | — | — | 1 1/2 | — | 3 1/4 | 3 7/16 | 7 11/16 | | |
| 12 | 3 1/2 | 3 1/4-12 | 2 1/2-12 | 3 1/2 | 4.249 | 1 | 3 | 3 3/8 | 1/2 | — | — | 1 1/2 | — | 3 1/4 | 3 7/16 | 7 11/16 | | |

Miller AV Series Heavy-Duty Air Cylinders

Cap Trunnion Mount
1" to 6" Bore Sizes

Cap Trunnion Mount

Model 82

1" - 1 1/2" - 2" - 2 1/2" - 5" and 6" Bore

With Maximum Oversize Rods

Retainer Held Bushing

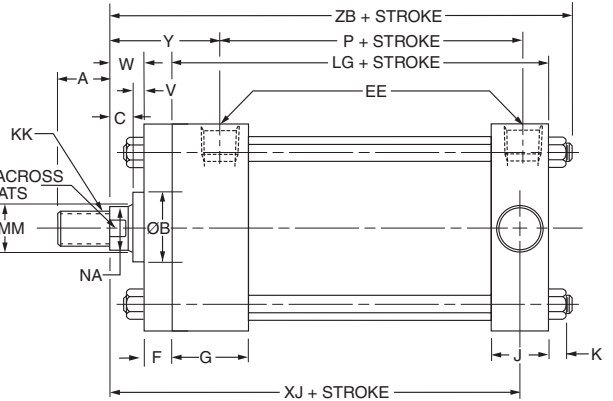
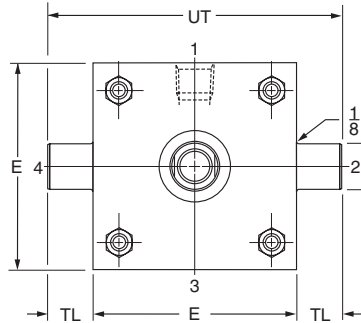
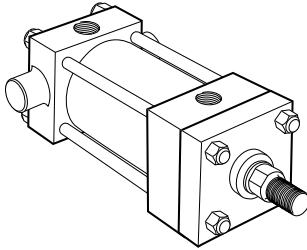

Before determining dimensions: See chart on page 3 for cylinder rod combinations that have removable bushings.

Cap Trunnion Mount

Model 82

1 1/2" - 6" Bore

Bolted Bushing

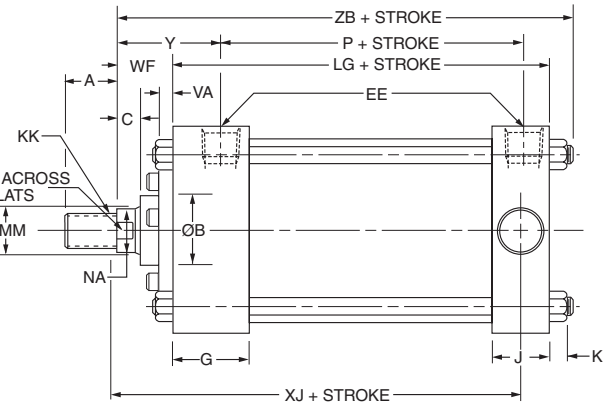
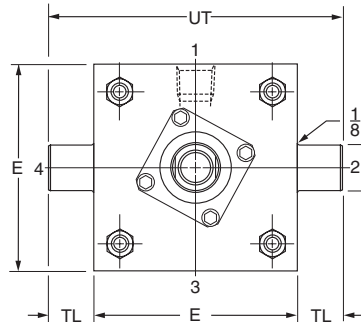
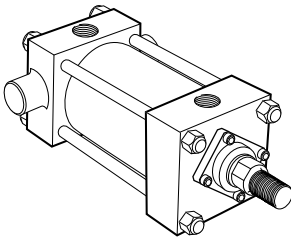

Rod End Dimensions — see table 2

Thread Style 2

Small Male

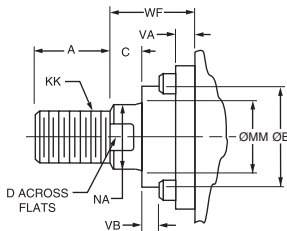

A high strength rod end stud is supplied on thread style 2 through 2" diameter rods and on thread style 5 through 1 3/8" diameter rods. Larger sizes or special rod ends are cut threads. Style 2 rod ends are recommended where the workpiece is secured against the rod shoulder. When the workpiece is not shouldered, style 2 rod ends

Thread Style 4

Short Female

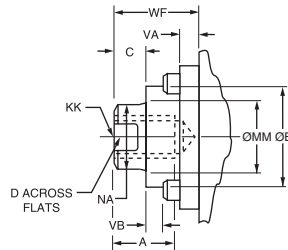

are recommended through 2" piston rod diameters and style 5 rod ends are recommended on larger diameters. Use style 4 for applications where female rod end threads are required. If rod end is not specified, style 2 will be supplied.

Thread Style 5

Intermediate Male

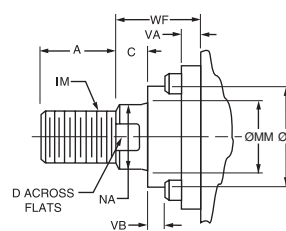

"Special" Thread Style X

Special thread, extension, rod eye, blank, etc., are also available.

To order, specify "Style X" and give desired dimensions for KK, A, W or WF. If otherwise special, furnish dimensioned sketch.

Miller AV Series Heavy-Duty Air Cylinders

Cap Trunnion Mount
1" to 6" Bore Sizes

Table 1—Envelope and Mounting Dimensions

| Bore | E | EE NPTF | F | G | J | K | TD Ø +.000 -.001 | TL | UT | Add Stroke | |
|-------|-------|------------|-----|-------|-------|------|------------------------|-------|-------|------------|-------|
| | | | | | | | | | | LG | P |
| 1 | ■ | 1/4 | 3/8 | 1 1/2 | 1 | 3/16 | .750 | 3/4 | 3 | 3 1/2 | 2 1/8 |
| 1 1/2 | 2 | 3/8† | 3/8 | 1 1/2 | 1 | 1/4 | 1.000 | 1 | 4 | 3 5/8 | 2 1/4 |
| 2 | 2 1/2 | 3/8† | 3/8 | 1 1/2 | 1 | 5/16 | 1.000 | 1 | 4 1/2 | 3 5/8 | 2 1/4 |
| 2 1/2 | 3 | 3/8† | 3/8 | 1 1/2 | 1 | 5/16 | 1.000 | 1 | 5 | 3 3/4 | 2 3/8 |
| 3 1/4 | 3 3/4 | 1/2 | — | 1 3/4 | 1 1/4 | 3/8 | 1.000 | 1 | 5 3/4 | 4 1/4 | 2 5/8 |
| 4 | 4 1/2 | 1/2 | — | 1 3/4 | 1 1/4 | 3/8 | 1.000 | 1 | 6 1/2 | 4 1/4 | 2 5/8 |
| 5 | 5 1/2 | 1/2 | 5/8 | 1 3/4 | 1 1/4 | 7/16 | 1.000 | 1 | 7 1/2 | 4 1/2 | 2 7/8 |
| 6 | 6 1/2 | 3/4 | 3/4 | 2 | 1 1/2 | 7/16 | 1.375 | 1 3/8 | 9 1/4 | 5 | 3 1/8 |

† On 1 1/2", 2" and 2 1/2" bore sizes, the head-end (only) pipe thread is not full depth on cylinders with maximum oversize rods. Minimum of three full threads available.

■ 1" bore head is 1 3/4" x 1 1/2".

Table 2—Rod End Dimensions and Envelope Dimensions Affected By Rod Size

| Bore | MM Rod Ø | Thread | | Rod Extensions and Envelope Dimensions Affected By Rod Size | | | | | | | | | | | | Add Stroke | |
|-------|----------------|------------------|----------------------|---|-----------------------|-----|---------|---------|-----|-----|--------|-------|--------|---------|---------|------------|--|
| | | Style 5 IM | Style 2 & 4 KK | A | B Ø +.000 -.002 | C | D | NA | V | VA | VB | W | WF | Y | XJ | ZB | |
| | | | | | | | | | | | | | | | | | |
| 1 | 1/2 | 7/16-20 | 5/16-24 | 5/8 | .999 | 3/8 | 3/8 | 7/16 | 1/4 | — | — | 5/8 | — | 1 5/16 | 4 | 4 11/16 | |
| | 5/8 | 1/2-20 | 7/16-20 | 3/4 | 1.124 | 3/8 | 1/2 | 9/16 | 1/4 | — | — | 5/8 | — | 1 5/16 | 4 | 4 11/16 | |
| 1 1/2 | 5/8 | 1/2-20 | 7/16-20 | 3/4 | 1.124 | 3/8 | 1/2 | 9/16 | — | 1/4 | 3/16 | — | 1 | 1 5/16 | 4 1/8 | 4 7/8 | |
| | 1 | 7/8-14 | 3/4-16 | 1 1/8 | 1.499 | 1/2 | 7/8 | 1 5/16 | 1/2 | — | — | 1 | — | 2 5/16 | 4 1/2 | 5 1/4 | |
| 2 | 5/8 | 1/2-20 | 7/16-20 | 3/4 | 1.124 | 3/8 | 1/2 | 9/16 | — | 1/4 | 3/16 | — | 1 | 1 5/16 | 4 1/8 | 4 5/16 | |
| | 1 3/8 | 1 1/4-12 | 1-14 | 1 5/8 | 1.999 | 5/8 | 1 1/8 | 1 5/16 | 5/8 | — | — | 1 1/4 | — | 2 9/16 | 4 3/4 | 5 9/16 | |
| | 1 | 7/8-14 | 3/4-16 | 1 1/8 | 1.499 | 1/2 | 7/8 | 1 5/16 | — | 1/4 | 3/8 | — | 1 3/8 | 2 5/16 | 4 1/2 | 5 5/16 | |
| 2 1/2 | 5/8 | 1/2-20 | 7/16-20 | 3/4 | 1.124 | 3/8 | 1/2 | 9/16 | — | 1/4 | 3/16 | — | 1 | 1 5/16 | 4 1/4 | 5 1/16 | |
| | 1 3/4 | 1 1/2-12 | 1 1/4-12 | 2 | 2.374 | 3/4 | 1 1/2 | 1 11/16 | 3/4 | — | — | 1 1/2 | — | 2 13/16 | 5 1/8 | 5 5/16 | |
| | 1 | 7/8-14 | 3/4-16 | 1 1/8 | 1.499 | 1/2 | 7/8 | 1 5/16 | — | 1/4 | 3/8 | — | 1 3/8 | 2 5/16 | 4 5/8 | 5 7/16 | |
| | 1 3/8 | 1 1/4-12 | 1-14 | 1 5/8 | 1.999 | 5/8 | 1 1/8 | 1 5/16 | 5/8 | — | — | 1 1/4 | 1 5/8 | 2 5/16 | 4 7/8 | 5 11/16 | |
| 3 1/4 | 1 | 7/8-14 | 3/4-16 | 1 1/8 | 1.499 | 1/2 | 7/8 | 1 5/16 | — | 1/4 | 3/8 | — | 1 3/8 | 2 7/16 | 5 | 6 | |
| | 2 | 1 3/4-12 | 1 1/2-12 | 2 1/4 | 2.624 | 7/8 | 1 11/16 | 1 5/16 | — | 1/4 | 9/16 | — | 2 | 3 1/16 | 5 5/8 | 6 5/8 | |
| | 1 3/8 | 1 1/4-12 | 1-14 | 1 5/8 | 1.999 | 5/8 | 1 1/8 | 1 5/16 | — | 1/4 | 1/2 | — | 1 5/8 | 2 11/16 | 5 1/4 | 6 1/4 | |
| | 1 3/4 | 1 1/2-12 | 1 1/4-12 | 2 | 2.374 | 3/4 | 1 1/2 | 1 11/16 | — | 1/4 | 9/16 | — | 1 7/8 | 2 5/16 | 5 1/2 | 6 1/2 | |
| 4 | 1 | 7/8-14 | 3/4-16 | 1 1/8 | 1.499 | 1/2 | 7/8 | 1 5/16 | — | 1/4 | 3/8 | — | 1 3/8 | 2 5/16 | 5 | 6 | |
| | 2 1/2 | 2 1/4-12 | 1 7/8-12 | 3 | 3.124 | 1 | 2 1/16 | 2 9/8 | — | 1/4 | 1 1/16 | — | 2 1/4 | 3 5/16 | 5 7/8 | 6 7/8 | |
| | 1 3/8 | 1 1/4-12 | 1-14 | 1 5/8 | 1.999 | 5/8 | 1 1/8 | 1 5/16 | — | 1/4 | 1/2 | — | 1 5/8 | 2 11/16 | 5 1/4 | 6 1/4 | |
| | 1 3/4 | 1 1/2-12 | 1 1/4-12 | 2 | 2.374 | 3/4 | 1 1/2 | 1 11/16 | — | 1/4 | 9/16 | — | 1 7/8 | 2 5/16 | 5 1/2 | 6 1/2 | |
| | 2 | 1 3/4-12 | 1 1/2-12 | 2 1/4 | 2.624 | 7/8 | 1 11/16 | 1 5/16 | — | 1/4 | 9/16 | — | 2 | 3 1/16 | 5 5/8 | 6 5/8 | |
| 5 | 1 | 7/8-14 | 3/4-16 | 1 1/8 | 1.499 | 1/2 | 7/8 | 1 5/16 | — | 1/4 | 3/8 | — | 1 3/8 | 2 7/16 | 5 1/4 | 6 5/16 | |
| | 3 1/2 | 3 1/4-12 | 2 1/2-12 | 3 1/2 | 4.249 | 1 | 3 | 3 3/8 | 5/8 | — | — | 1 5/8 | — | 3 5/16 | 6 1/8 | 7 3/16 | |
| | 1 3/8 | 1 1/4-12 | 1-14 | 1 5/8 | 1.999 | 5/8 | 1 1/8 | 1 5/16 | — | 1/4 | 1/2 | — | 1 5/8 | 2 11/16 | 5 1/2 | 6 9/16 | |
| | 1 3/4 | 1 1/2-12 | 1 1/4-12 | 2 | 2.374 | 3/4 | 1 1/2 | 1 11/16 | — | 1/4 | 9/16 | — | 1 7/8 | 2 5/16 | 5 3/4 | 6 13/16 | |
| | 2 | 1 3/4-12 | 1 1/2-12 | 2 1/4 | 2.624 | 7/8 | 1 11/16 | 1 5/16 | — | 1/4 | 9/16 | — | 2 | 3 1/16 | 5 7/8 | 6 15/16 | |
| | 2 1/2 | 2 1/4-12 | 1 7/8-12 | 3 | 3.124 | 1 | 2 1/16 | 2 9/8 | — | 1/4 | 1 1/16 | — | 2 1/4 | 3 5/16 | 6 1/8 | 7 3/16 | |
| 6 | 3 | 2 3/4-12 | 2 1/4-12 | 3 1/2 | 3.749 | 1 | 2 5/8 | 2 7/8 | 5/8 | — | — | 1 5/8 | — | 3 5/16 | 6 1/8 | 7 3/16 | |
| | 1 3/8 | 1 1/4-12 | 1-14 | 1 5/8 | 1.999 | 5/8 | 1 1/8 | 1 5/16 | — | 1/4 | 7/16 | — | 1 5/8 | 2 13/16 | 5 7/8 | 7 1/16 | |
| | 4 | 3 3/4-12 | 3-12 | 4 | 4.749 | 1 | 3 3/8 | 3 7/8 | 1/2 | — | — | 1 1/2 | — | 3 7/16 | 6 1/2 | 7 11/16 | |
| | 1 3/4 | 1 1/2-12 | 1 1/4-12 | 2 | 2.374 | 3/4 | 1 1/2 | 1 11/16 | — | 1/4 | 9/16 | — | 1 7/8 | 3 1/16 | 6 1/8 | 7 5/16 | |
| | 2 | 1 3/4-12 | 1 1/2-12 | 2 1/4 | 2.624 | 7/8 | 1 11/16 | 1 5/16 | — | 1/4 | 9/16 | — | 2 | 3 3/16 | 6 1/4 | 7 7/16 | |
| | 2 1/2 | 2 1/4-12 | 1 7/8-12 | 3 | 3.124 | 1 | 2 1/16 | 2 9/8 | — | 1/4 | 1 1/16 | — | 2 1/4 | 3 7/16 | 6 1/2 | 7 11/16 | |
| | 3 | 2 3/4-12 | 2 1/4-12 | 3 1/2 | 3.749 | 1 | 2 5/8 | 2 7/8 | 1/2 | — | — | 1 1/2 | — | 3 7/16 | 6 1/2 | 7 11/16 | |
| 3 1/2 | 3 1/4-12 | 2 1/2-12 | 3 1/2 | 4.249 | 1 | 3 | 3 3/8 | 1/2 | — | — | 1 1/2 | — | 3 7/16 | 6 1/2 | 7 11/16 | | |

Miller AV Series Heavy-Duty Air Cylinders

Intermediate Trunnion Mount
1 1/2" to 6" Bore Sizes

Intermediate Trunnion Mount
Model 89
1 1/2" - 2" - 2 1/2" - 5" and 6" Bore
With Maximum Oversize Rods

Retainer Held Bushing

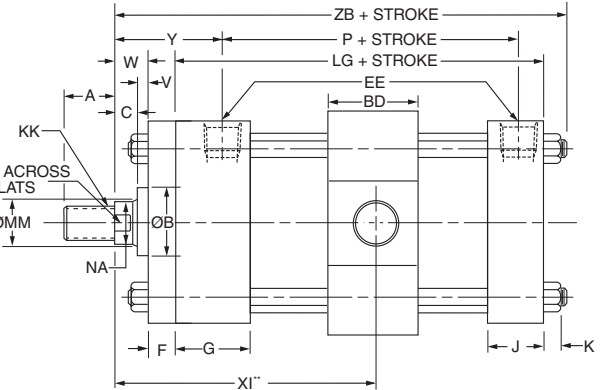
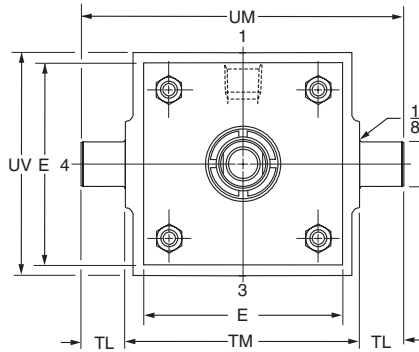
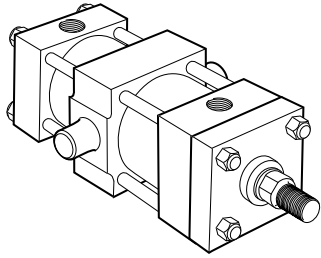

**Dimension "XI" to be specified by customer.

Before determining dimensions: See chart on page 3 for cylinder rod combinations that have removable bushings.

Intermediate Trunnion Mount
Model 89
1 1/2" - 6" Bore

Bolted Bushing

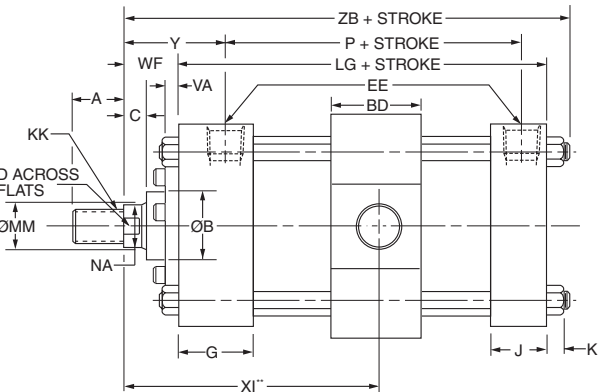
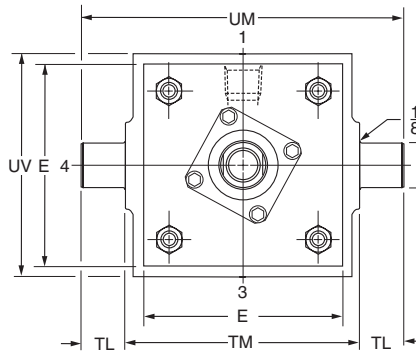
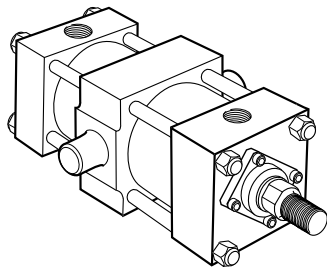

**Dimension "XI" to be specified by customer.

Rod End Dimensions — see table 2

Thread Style 2
Small Male

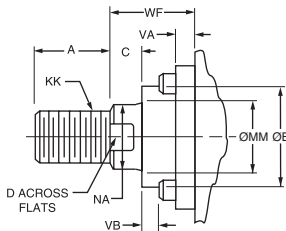

Thread Style 4
Short Female

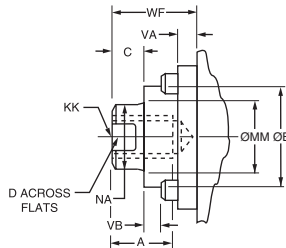

Thread Style 5
Intermediate Male

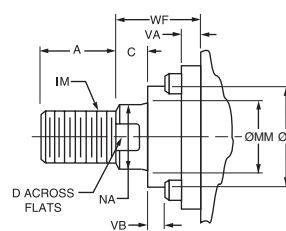

"Special" Thread Style X

Special thread, extension, rod eye, blank, etc., are also available.

To order, specify "Style X" and give desired dimensions for KK, A, W or WF. If otherwise special, furnish dimensioned sketch.

A high strength rod end stud is supplied on thread style 2 through 2" diameter rods and on thread style 5 through 1 3/8" diameter rods. Larger sizes or special rod ends are cut threads. Style 2 rod ends are recommended where the workpiece is secured against the rod shoulder. When the workpiece is not shouldered, style 2 rod ends

are recommended through 2" piston rod diameters and style 5 rod ends are recommended on larger diameters. Use style 4 for applications where female rod end threads are required. If rod end is not specified, style 2 will be supplied.

Miller AV Series Heavy-Duty Air Cylinders

Intermediate Trunnion Mount
1 1/2" to 6" Bore Sizes

Table 1—Envelope and Mounting Dimensions

| Bore | BD | E | EE NPTF | F | G | J | K | TD Ø +0.000 -0.001 | TL | TM | UM | UV | Minimum Stroke | Add Stroke | |
|-------|-------|-------|------------|-----|-------|-------|------|--------------------------|-------|-------|--------|-------|-------------------|------------|-------|
| | | | | | | | | | | | | | | LG | P |
| 1 1/2 | 1 1/4 | 2 | 3/8† | 3/8 | 1 1/2 | 1 | 1/4 | 1.000 | 1 | 2 1/2 | 4 1/2 | 2 1/2 | 1/4 | 3 5/8 | 2 1/4 |
| 2 | 1 1/2 | 2 1/2 | 3/8† | 3/8 | 1 1/2 | 1 | 5/16 | 1.000 | 1 | 3 | 5 | 3 | 1/2 | 3 5/8 | 2 1/4 |
| 2 1/2 | 1 1/2 | 3 | 3/8† | 3/8 | 1 1/2 | 1 | 5/16 | 1.000 | 1 | 3 1/2 | 5 1/2 | 3 1/2 | 3/8 | 3 3/4 | 2 3/8 |
| 3 1/4 | 2 | 3 3/4 | 1/2 | 5/8 | 1 3/4 | 1 1/4 | 3/8 | 1.000 | 1 | 4 1/2 | 6 1/2 | 4 1/4 | 7/8 | 4 1/4 | 2 5/8 |
| 4 | 2 | 4 1/2 | 1/2 | — | 1 3/4 | 1 1/4 | 3/8 | 1.000 | 1 | 5 1/4 | 7 1/4 | 5 | 7/8 | 4 1/4 | 2 5/8 |
| 5 | 2 | 5 1/2 | 1/2 | — | 1 3/4 | 1 1/4 | 7/16 | 1.000 | 1 | 6 1/4 | 8 1/4 | 6 | 5/8 | 4 1/2 | 2 7/8 |
| 6 | 2 1/2 | 6 1/2 | 3/4 | 3/4 | 2 | 1 1/2 | 7/16 | 1.375 | 1 3/8 | 7 5/8 | 10 3/8 | 7 | 1 1/8 | 5 | 3 1/8 |

† On 1 1/2", 2" and 2 1/2" bore sizes, the head-end (only) pipe thread is not full depth on cylinders with maximum oversize rods. Minimum of three full threads available.

Table 2—Rod End Dimensions and Envelope Dimensions Affected By Rod Size

| Bore | MM Rod Ø | Thread | | Rod Extensions and Envelope Dimensions Affected By Rod Size | | | | | | | | | | | | | | Add Stroke ZB |
|-------|----------------|------------------|----------------------|---|-------|-------------------------|-----|---------|---------|-----|-----|--------|-------|-------|--------------|---------|---------|------------------|
| | | Style 5 IM | Style 2 & 4 KK | LL | A | B Ø +0.000 -0.002 | C | D | NA | V | VA | VB | W | WF | Min. XI** | Y | | |
| | | | | | | | | | | | | | | | | | | |
| 1 1/2 | 5/8 | 1/2-20 | 7/16-20 | 1/2-20 | 3/4 | 1.124 | 3/8 | 1/2 | 9/16 | — | 1/4 | 3/16 | — | 1 | 3 3/16 | 1 15/16 | 4 7/8 | |
| | 1 | 7/8-14 | 3/4-16 | 7/8-14 | 1 1/8 | 1.499 | 1/2 | 7/8 | 15/16 | 1/2 | — | — | 1 | — | 3 9/16 | 2 5/16 | 5 1/4 | |
| 2 | 5/8 | 1/2-20 | 7/16-20 | 1/2-20 | 3/4 | 1.124 | 3/8 | 1/2 | 9/16 | — | 1/4 | 3/16 | — | 1 | 3 5/16 | 1 15/16 | 4 5/16 | |
| | 1 3/8 | 1 1/4-12 | 1-14 | 1 1/4-12 | 1 5/8 | 1.999 | 5/8 | 1 1/8 | 1 5/16 | 5/8 | — | — | 1 1/4 | — | 3 15/16 | 2 9/16 | 5 9/16 | |
| 2 1/2 | 1 3/8 | 1 1/4-12 | 1-14 | 1 1/4-12 | 1 5/8 | 1.999 | 5/8 | 1 1/8 | 1 5/16 | 5/8 | — | — | 1 1/4 | — | 3 15/16 | 2 9/16 | 5 9/16 | |
| | 1 | 7/8-14 | 3/4-16 | 7/8-14 | 1 1/8 | 1.499 | 1/2 | 7/8 | 15/16 | — | 1/4 | 3/8 | — | 1 3/8 | 3 11/16 | 2 5/16 | 5 7/16 | |
| 3 1/4 | 5/8 | 1/2-20 | 7/16-20 | 1/2-20 | 3/4 | 1.124 | 3/8 | 1/2 | 9/16 | — | 1/4 | 3/16 | — | 1 | 3 5/16 | 1 15/16 | 5 1/16 | |
| | 1 3/4 | 1 1/2-12 | 1 1/4-12 | 1 1/2-12 | 2 | 2.374 | 3/4 | 1 1/2 | 1 11/16 | 3/4 | — | — | 1 1/2 | — | 4 3/16 | 2 13/16 | 5 15/16 | |
| 3 1/4 | 1 | 7/8-14 | 3/4-16 | 7/8-14 | 1 1/8 | 1.499 | 1/2 | 7/8 | 15/16 | — | 1/4 | 3/8 | — | 1 3/8 | 3 11/16 | 2 5/16 | 5 7/16 | |
| | 1 3/8 | 1 1/4-12 | 1-14 | 1 1/4-12 | 1 5/8 | 1.999 | 5/8 | 1 1/8 | 1 5/16 | 5/8 | — | — | 1 1/4 | — | 3 15/16 | 2 9/16 | 5 11/16 | |
| 4 | 1 | 7/8-14 | 3/4-16 | 7/8-14 | 1 1/8 | 1.499 | 1/2 | 7/8 | 15/16 | — | 1/4 | 3/8 | — | 1 3/8 | 3 11/16 | 2 5/16 | 5 7/16 | |
| | 2 | 1 3/4-12 | 1 1/2-12 | 1 3/4-12 | 2 1/4 | 2.624 | 7/8 | 1 11/16 | 1 15/16 | — | 1/4 | 9/16 | — | 2 | 4 13/16 | 3 1/16 | 6 5/8 | |
| 4 | 1 3/8 | 1 1/4-12 | 1-14 | 1 1/4-12 | 1 5/8 | 1.999 | 5/8 | 1 1/8 | 1 5/16 | — | 1/4 | 1/2 | — | 1 5/8 | 4 7/16 | 2 11/16 | 6 1/4 | |
| | 2 1/2 | 2 1/4-12 | 1 7/8-12 | 2 1/4-12 | 3 | 3.124 | 1 | 2 1/16 | 2 3/8 | — | 1/4 | 1 1/16 | — | 2 1/4 | 5 1/16 | 3 5/16 | 6 7/8 | |
| 5 | 1 3/4 | 1 1/2-12 | 1 1/4-12 | 1 1/2-12 | 2 | 2.374 | 3/4 | 1 1/2 | 1 11/16 | — | 1/4 | 9/16 | — | 1 7/8 | 4 11/16 | 2 15/16 | 6 1/2 | |
| | 2 | 1 3/4-12 | 1 1/2-12 | 1 3/4-12 | 2 1/4 | 2.624 | 7/8 | 1 11/16 | 1 15/16 | — | 1/4 | 9/16 | — | 2 | 4 13/16 | 3 1/16 | 6 5/8 | |
| 5 | 1 | 7/8-14 | 3/4-16 | 7/8-14 | 1 1/8 | 1.499 | 1/2 | 7/8 | 15/16 | — | 1/4 | 3/8 | — | 1 3/8 | 4 3/16 | 2 7/16 | 6 | |
| | 3 1/2 | 3 1/4-12 | 2 1/2-12 | 3 1/4-12 | 3 1/2 | 4.249 | 1 | 3 | 3 3/8 | 5/8 | — | — | 1 5/8 | — | 5 1/16 | 3 5/16 | 7 3/16 | |
| 5 | 1 3/8 | 1 1/4-12 | 1-14 | 1 1/4-12 | 1 5/8 | 1.999 | 5/8 | 1 1/8 | 1 5/16 | — | 1/4 | 1/2 | — | 1 5/8 | 4 7/16 | 2 11/16 | 6 9/16 | |
| | 2 1/2 | 2 1/4-12 | 1 7/8-12 | 2 1/4-12 | 3 | 3.124 | 1 | 2 1/16 | 2 3/8 | — | 1/4 | 1 1/16 | — | 2 1/4 | 5 1/16 | 3 5/16 | 7 3/16 | |
| 6 | 1 3/4 | 1 1/2-12 | 1 1/4-12 | 1 1/2-12 | 2 | 2.374 | 3/4 | 1 1/2 | 1 11/16 | — | 1/4 | 9/16 | — | 1 7/8 | 4 11/16 | 2 15/16 | 6 13/16 | |
| | 2 | 1 3/4-12 | 1 1/2-12 | 1 3/4-12 | 2 1/4 | 2.624 | 7/8 | 1 11/16 | 1 15/16 | — | 1/4 | 9/16 | — | 2 | 4 13/16 | 3 1/16 | 6 5/8 | |
| 6 | 1 3/8 | 1 1/4-12 | 1-14 | 1 1/4-12 | 1 5/8 | 1.999 | 5/8 | 1 1/8 | 1 5/16 | — | 1/4 | 7/16 | — | 1 5/8 | 4 15/16 | 2 13/16 | 7 1/16 | |
| | 4 | 3 3/4-12 | 3-12 | 3 3/4-12 | 4 | 4.749 | 1 | 3 3/8 | 3 7/8 | 1/2 | — | — | 1 1/2 | — | 5 9/16 | 3 7/16 | 7 11/16 | |
| 6 | 2 1/2 | 2 1/4-12 | 1 7/8-12 | 2 1/4-12 | 3 | 3.124 | 1 | 2 1/16 | 2 3/8 | — | 1/4 | 1 1/16 | — | 2 1/4 | 5 9/16 | 3 11/16 | 7 5/16 | |
| | 3 | 2 3/4-12 | 2 1/4-12 | 2 3/4-12 | 3 1/2 | 3.749 | 1 | 2 5/8 | 2 7/8 | 1/2 | — | — | 1 1/2 | — | 5 9/16 | 3 7/16 | 7 11/16 | |
| 6 | 3 1/2 | 3 1/4-12 | 2 1/2-12 | 3 1/4-12 | 3 1/2 | 4.249 | 1 | 3 | 3 3/8 | 1/2 | — | — | 1 1/2 | — | 5 9/16 | 3 7/16 | 7 11/16 | |

** Dimension XI to be specified by customer.

Miller AV Series Heavy-Duty Air Cylinders

Cap Fixed Clevis Mount
1" to 6" Bore Sizes

Cap Fixed Clevis Mount

Model 84

1" - 1 1/2" - 2" - 2 1/2" - 5" and 6" Bore
With Maximum Oversize Rods

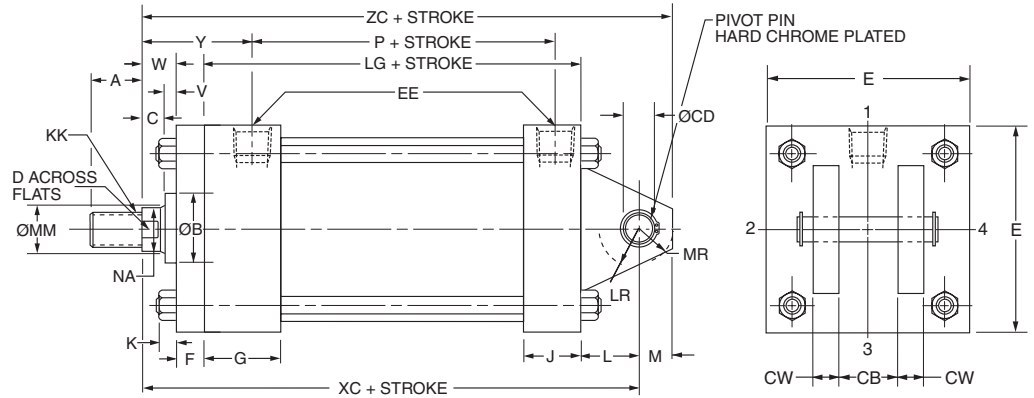
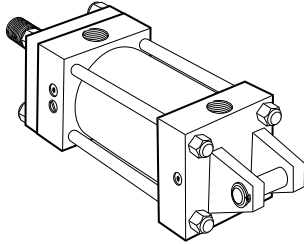

Note: Cap tie rod nuts not on 1 1/2", 2", 2 1/2"
and 3 1/4" bores.

Before determining dimensions: See chart on page 3 for
cylinder rod combinations that have removable bushings.

Cap Fixed Clevis Mount

Model 84

1 1/2" - 6" Bore

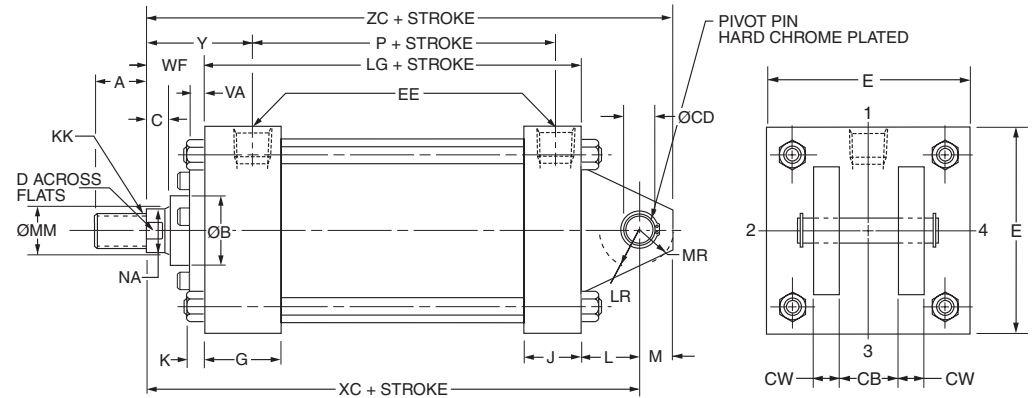
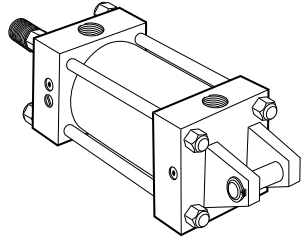

Note: Cap tie rod nuts not on 1 1/2", 2", 2 1/2"
and 3 1/4" bores.

Rod End Dimensions — see table 2

Thread Style 2

Small Male

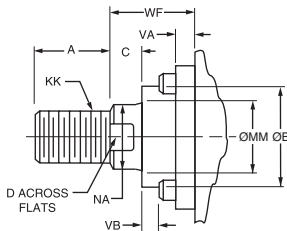

A high strength rod end stud is supplied on thread style 2 through 2" diameter rods and on thread style 5 through 1 3/8" diameter rods. Larger sizes or special rod ends are cut threads. Style 2 rod ends are recommended where the workpiece is secured against the rod shoulder. When the workpiece is not shouldered, style 2 rod ends

Thread Style 4

Short Female

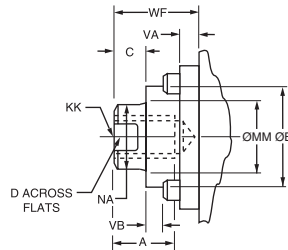

are recommended through 2" piston rod diameters and style 5 rod ends are recommended on larger diameters. Use style 4 for applications where female rod end threads are required. If rod end is not specified, style 2 will be supplied.

Thread Style 5

Intermediate Male

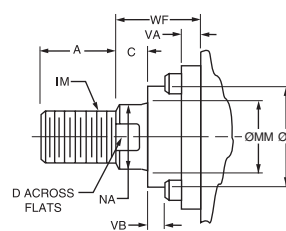

"Special" Thread Style X

Special thread, extension, rod eye, blank, etc., are also available.

To order, specify "Style X" and give desired dimensions for KK, A, W or WF. If otherwise special, furnish dimensioned sketch.

Miller AV Series Heavy-Duty Air Cylinders

Cap Fixed Clevis Mount
1" to 6" Bore Sizes

Table 1—Envelope and Mounting Dimensions

| Bore | CB | CD Ø ⁺ +.000 -.002 | CW | E | EE NPTF | F | G | J | K | L | LR | M | MR | Add Stroke | |
|-------|-------|-------------------------------------|-----|-------|------------|-----|-------|-------|------|-------|-------|-------|------|------------|-------|
| | | | | | | | | | | | | | | LG | P |
| 1 | * | .441* | * | ■ | 1/4 | 3/8 | 1 1/2 | 1 | 3/16 | 1/2* | 1/2* | 7/16* | 1/2* | 3 1/2* | 2 1/8 |
| 1 1/2 | 3/4 | .501 | 1/2 | 2 | 3/8† | 3/8 | 1 1/2 | 1 | 1/4 | 3/4 | 3/4 | 1/2 | 5/8 | 3 5/8 | 2 1/4 |
| 2 | 3/4 | .501 | 1/2 | 2 1/2 | 3/8† | 3/8 | 1 1/2 | 1 | 5/16 | 3/4 | 3/4 | 1/2 | 5/8 | 3 3/8 | 2 1/4 |
| 2 1/2 | 3/4 | .501 | 1/2 | 3 | 3/8† | 3/8 | 1 1/2 | 1 | 5/16 | 3/4 | 3/4 | 1/2 | 5/8 | 3 3/4 | 2 3/8 |
| 3 1/4 | 1 1/4 | .751 | 5/8 | 3 3/4 | 1/2 | — | 1 3/4 | 1 1/4 | 3/8 | 1 1/4 | 1 | 3/4 | 3/4 | 4 1/4 | 2 5/8 |
| 4 | 1 1/4 | .751 | 5/8 | 4 1/2 | 1/2 | — | 1 3/4 | 1 1/4 | 3/8 | 1 1/4 | 1 | 3/4 | 3/4 | 4 1/4 | 2 5/8 |
| 5 | 1 1/4 | .751 | 5/8 | 5 1/2 | 1/2 | 5/8 | 1 3/4 | 1 1/4 | 7/16 | 1 1/4 | 1 | 3/4 | 3/4 | 4 1/2 | 2 7/8 |
| 6 | 1 1/2 | 1.001 | 3/4 | 6 1/2 | 3/4 | 3/4 | 2 | 1 1/2 | 7/16 | 1 1/2 | 1 1/4 | 1 | 1 | 5 | 3 1/8 |

† On 1 1/2", 2" and 2 1/2" bore sizes, the head-end (only) pipe thread is not full depth on cylinders with maximum oversize rods. Minimum of three full threads available.

■ 1" bore head is 1 3/4" x 1 1/2".

* In 1" bore size model only, a single eye mounting, 7/16" thick, is used. Dimension CD (.441") is hole diameter — pin not supplied.

• Dimension CD is pin diameter except in 1" bore.

Table 2—Rod End Dimensions and Envelope Dimensions Affected By Rod Size

| Bore | MM Rod Ø | Thread | | Rod Extensions and Envelope Dimensions Affected By Rod Size | | | | | | | | | | | Add Stroke | |
|-------|----------|------------|----------------|---|-----------------------|-----|---------|---------|-----|-----|--------|-------|-------|---------|------------|--------|
| | | Style 5 IM | Style 2 & 4 KK | A | B Ø +.000 -.002 | C | D | NA | V | VA | VB | W | WF | Y | XC | ZC |
| 1 | 1/2 | 7/16-20 | 5/16-20 | 5/8 | .999 | 3/8 | 3/8 | 7/16 | 1/4 | — | — | 5/8 | — | 1 5/16 | 5 | 5 7/16 |
| | 5/8 | 1/2-20 | 7/16-20 | 3/4 | 1.124 | 3/8 | 1/2 | 9/16 | 1/4 | — | — | 5/8 | — | 1 5/16 | 5 | 5 7/16 |
| 1 1/2 | 5/8 | 1/2-20 | 7/16-20 | 3/4 | 1.124 | 3/8 | 1/2 | 9/16 | — | 1/4 | 3/16 | — | 1 | 1 5/16 | 5 3/8 | 5 7/8 |
| | 1 | 7/8-14 | 3/4-16 | 1 1/8 | 1.499 | 1/2 | 7/8 | 1 5/16 | 1/2 | — | — | 1 | — | 2 5/16 | 5 3/4 | 6 1/4 |
| 2 | 5/8 | 1/2-20 | 7/16-20 | 3/4 | 1.124 | 3/8 | 1/2 | 9/16 | — | 1/4 | 3/16 | — | 1 | 1 5/16 | 5 3/8 | 5 7/8 |
| | 1 3/8 | 1 1/4-12 | 1-14 | 1 5/8 | 1.999 | 5/8 | 1 1/8 | 1 5/16 | 5/8 | — | — | 1 1/4 | — | 2 9/16 | 6 | 6 1/2 |
| 2 1/2 | 1 | 7/8-14 | 3/4-16 | 1 1/8 | 1.499 | 1/2 | 7/8 | 1 5/16 | — | 1/4 | 3/8 | — | 1 3/8 | 2 5/16 | 5 3/4 | 6 1/4 |
| | 5/8 | 1/2-20 | 7/16-20 | 3/4 | 1.124 | 3/8 | 1/2 | 9/16 | — | 1/4 | 3/16 | — | 1 | 1 5/16 | 5 1/2 | 6 |
| 3 1/4 | 1 3/4 | 1 1/2-12 | 1 1/4-12 | 2 | 2.374 | 3/4 | 1 1/2 | 1 11/16 | 3/4 | — | — | 1 1/2 | — | 2 3/16 | 6 3/8 | 6 7/8 |
| | 1 | 7/8-14 | 3/4-16 | 1 1/8 | 1.499 | 1/2 | 7/8 | 1 5/16 | — | 1/4 | 3/8 | — | 1 3/8 | 2 5/16 | 5 7/8 | 6 3/8 |
| 4 | 1 3/8 | 1 1/4-12 | 1-14 | 1 5/8 | 1.999 | 5/8 | 1 1/8 | 1 5/16 | 5/8 | — | — | 1 1/4 | 1 5/8 | 2 7/16 | 6 1/8 | 6 5/8 |
| | 2 1/2 | 2 1/4-12 | 1 7/8-12 | 3 | 3.124 | 1 | 2 1/16 | 2 3/8 | — | 1/4 | 1 1/16 | — | 2 1/4 | 3 5/16 | 7 3/4 | 8 1/2 |
| 5 | 1 3/8 | 1 1/4-12 | 1-14 | 1 5/8 | 1.999 | 5/8 | 1 1/8 | 1 5/16 | — | 1/4 | 1/2 | — | 1 5/8 | 2 11/16 | 7 1/8 | 7 7/8 |
| | 1 | 7/8-14 | 3/4-16 | 1 1/8 | 1.499 | 1/2 | 7/8 | 1 5/16 | — | 1/4 | 3/8 | — | 1 3/8 | 2 7/16 | 7 1/8 | 7 7/8 |
| 6 | 3 1/2 | 3 1/4-12 | 2 1/2-12 | 3 1/2 | 4.249 | 1 | 3 | 3 3/8 | 5/8 | — | — | 1 5/8 | — | 3 5/16 | 8 | 8 3/4 |
| | 1 3/8 | 1 1/4-12 | 1-14 | 1 5/8 | 1.999 | 5/8 | 1 1/8 | 1 5/16 | — | 1/4 | 7/16 | — | 1 5/8 | 2 13/16 | 8 1/8 | 9 1/8 |
| 6 | 1 3/4 | 1 1/2-12 | 1 1/4-12 | 2 | 2.374 | 3/4 | 1 1/2 | 1 11/16 | — | 1/4 | 9/16 | — | 1 7/8 | 3 1/16 | 8 3/8 | 9 3/8 |
| | 2 | 1 3/4-12 | 1 1/2-12 | 2 1/4 | 2.624 | 7/8 | 1 11/16 | 1 5/16 | — | 1/4 | 9/16 | — | 2 | 3 3/16 | 8 1/2 | 9 1/2 |
| 6 | 2 1/2 | 2 1/4-12 | 1 7/8-12 | 3 | 3.124 | 1 | 2 1/16 | 2 3/8 | — | 1/4 | 1 1/16 | — | 2 1/4 | 3 7/16 | 8 3/4 | 9 3/4 |
| | 3 | 2 3/4-12 | 2 1/4-12 | 3 1/2 | 3.749 | 1 | 2 5/8 | 2 7/8 | 5/8 | — | — | 1 5/8 | — | 3 5/16 | 8 | 8 3/4 |
| 6 | 1 3/8 | 1 1/4-12 | 1-14 | 1 5/8 | 1.999 | 5/8 | 1 1/8 | 1 5/16 | — | 1/4 | 7/16 | — | 1 5/8 | 2 13/16 | 8 1/8 | 9 1/8 |
| | 4 | 3 3/4-12 | 3-12 | 4 | 4.749 | 1 | 3 3/8 | 3 7/8 | 1/2 | — | — | 1 1/2 | — | 3 7/16 | 8 3/4 | 9 3/4 |
| 6 | 1 3/4 | 1 1/2-12 | 1 1/4-12 | 2 | 2.374 | 3/4 | 1 1/2 | 1 11/16 | — | 1/4 | 9/16 | — | 1 7/8 | 3 1/16 | 8 3/8 | 9 3/8 |
| | 2 | 1 3/4-12 | 1 1/2-12 | 2 1/4 | 2.624 | 7/8 | 1 11/16 | 1 5/16 | — | 1/4 | 9/16 | — | 2 | 3 3/16 | 8 1/2 | 9 1/2 |
| 6 | 2 1/2 | 2 1/4-12 | 1 7/8-12 | 3 | 3.124 | 1 | 2 1/16 | 2 3/8 | — | 1/4 | 1 1/16 | — | 2 1/4 | 3 7/16 | 8 3/4 | 9 3/4 |
| | 3 | 2 3/4-12 | 2 1/4-12 | 3 1/2 | 3.749 | 1 | 2 5/8 | 2 7/8 | 1/2 | — | — | 1 1/2 | — | 3 7/16 | 8 3/4 | 9 3/4 |
| 6 | 3 1/2 | 3 1/4-12 | 2 1/2-12 | 3 1/2 | 4.249 | 1 | 3 | 3 3/8 | 1/2 | — | — | 1 1/2 | — | 3 7/16 | 8 3/4 | 9 3/4 |

Miller AV Series Heavy-Duty Air Cylinders

Double Rod End Cylinders
1" to 6" Bore Sizes

Double Rod End Cylinders

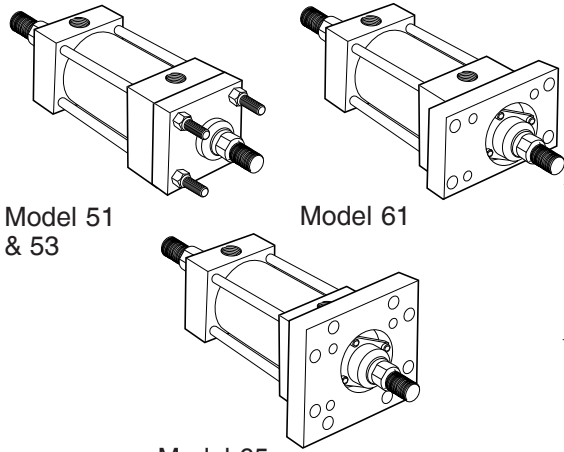

Retainer Held Bushing

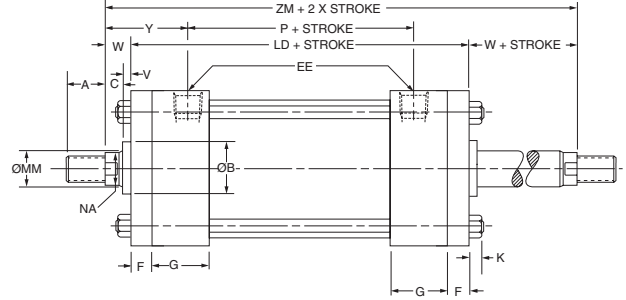
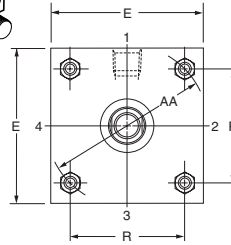

Note: The basic double rod cylinder dimensions are shown on this and facing page. For specific mounting dimensions, refer to pages for single rod cylinder. Exception: Model 72, "SS".

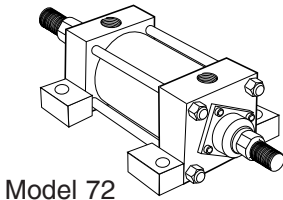

Model 72

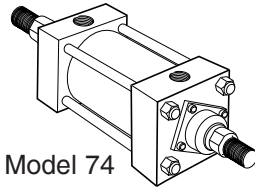

Model 74

Bolted Bushing

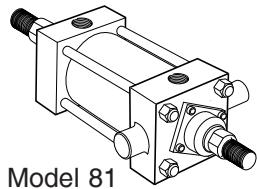
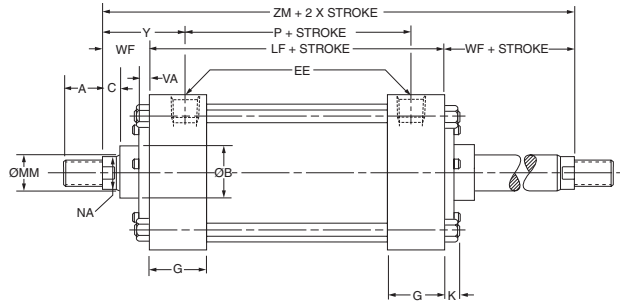
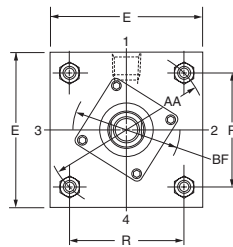

Model 81

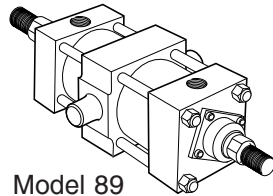

Model 89

Rod End Dimensions — see table 2

Thread Style 2 Small Male

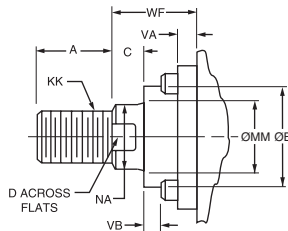

A high strength rod end stud is supplied on thread style 2 through 2" diameter rods and on thread style 5 through 1 3/8" diameter rods. Larger sizes or special rod ends are cut threads. Style 2 rod ends are recommended where the workpiece is secured against the rod shoulder. When the workpiece is not shouldered, style 2 rod ends

Thread Style 4 Short Female

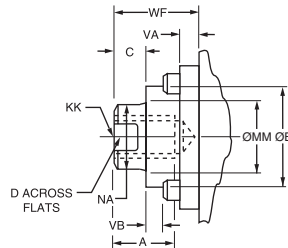

are recommended through 2" piston rod diameters and style 5 rod ends are recommended on larger diameters. Use style 4 for applications where female rod end threads are required. If rod end is not specified, style 2 will be supplied.

Thread Style 5 Intermediate Male

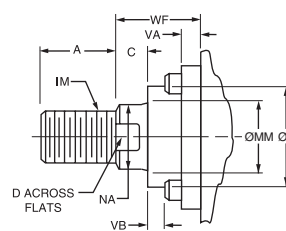

"Special" Thread Style X

Special thread, extension, rod eye, blank, etc., are also available.

To order, specify "Style X" and give desired dimensions for KK, A, W or WF. If otherwise special, furnish dimensioned sketch.

Miller AV Series Heavy-Duty Air Cylinders

Double Rod End Cylinders
1" to 6" Bore Sizes

Table 1—Envelope and Mounting Dimensions

| Bore | E | EE NPTF | F | G | K | SS | Add Stroke | | |
|-------|-------|------------|-----|-------|------|-------|------------|-------|-------|
| | | | | | | | LD | LF | P |
| 1 | ■ | 1/4 | 3/8 | 1 1/2 | 3/16 | 3 3/8 | 4 3/4 | — | 2 1/8 |
| 1 1/2 | 2 | 3/8† | 3/8 | 1 1/2 | 1/4 | 3 3/8 | 4 7/8 | 4 1/8 | 2 1/4 |
| 2 | 2 1/2 | 3/8† | 3/8 | 1 1/2 | 5/16 | 3 3/8 | 4 7/8 | 4 1/8 | 2 1/4 |
| 2 1/2 | 3 | 3/8† | 3/8 | 1 1/2 | 5/16 | 3 1/2 | 5 | 4 1/4 | 2 3/8 |
| 3 1/4 | 3 3/4 | 1/2 | 5/8 | 1 3/4 | 3/8 | 3 3/4 | 6 | 4 3/4 | 2 5/8 |
| 4 | 4 1/2 | 1/2 | 5/8 | 1 3/4 | 3/8 | 3 3/4 | 6 | 4 3/4 | 2 5/8 |
| 5 | 5 1/2 | 1/2 | 5/8 | 1 3/4 | 7/16 | 3 5/8 | 6 1/4 | 5 | 2 7/8 |
| 6 | 6 1/2 | 3/4 | 3/4 | 2 | 7/16 | 4 1/8 | 7 | 5 1/2 | 3 1/8 |

† On 1 1/2", 2" and 2 1/2" bore sizes, the head-end (only) pipe thread is not full depth on cylinders with maximum oversize rods. Minimum of three full threads available.

■ 1" bore head is 1 3/4" x 1 1/2".

How to Use Double Rod Cylinder Dimension Drawings

To determine dimensions for a double rod cylinder, first refer to the desired single rod mounting style cylinder shown on preceding pages of this catalog. After selecting necessary dimensions from that drawing, return to this page and supplement the single rod dimensions with those shown on the drawing and dimension table below. Note that double rod cylinders have a head (Dim. G) at both ends and that dimension LD replaces LB. The double rod dimensions differ from, or are in addition to those for single rod cylinders shown on preceding pages and provide the information needed to completely dimension a double rod cylinder. On a double rod cylinder where the two rod ends are different, be sure to clearly state which rod end is to be assembled at which end.

Port position 1 is standard. If other than standard, specify position 2, 3, or 4 when viewed from one end only.

Table 2—Rod End Dimensions and Envelope Dimensions Affected By Rod Size

| Bore | MM Rod Ø | Thread | | Rod Extensions and Envelope Dimensions Affected By Rod Size | | | | | | | | | | | | | Add Stroke ZM |
|-------|----------------|------------------|----------------------|---|-----------------------|-------|-----|---------|---------|-----|-----|--------|---------|-------|-------|-------|------------------|
| | | Style 5 IM | Style 2 & 4 KK | A | B Ø +.000 -.002 | BF | C | D | NA | V | VA | VB | Y | W | WF | | |
| 1 | 1/2 | 7/16-20 | 5/16-24 | 5/8 | .999 | — | 3/8 | 3/8 | 7/16 | 1/4 | — | — | 1 5/16 | 5/8 | — | 6 | |
| | 5/8 | 1/2-20 | 7/16-20 | 3/4 | 1.124 | — | 3/8 | 1/2 | 9/16 | 1/4 | — | — | 1 5/16 | 5/8 | — | 6 | |
| 1 1/2 | 5/8 | 1/2-20 | 7/16-20 | 3/4 | 1.124 | 1.968 | 3/8 | 1/2 | 9/16 | — | 1/4 | 3/16 | 1 5/16 | 5/8 | 1 | 6 1/8 | |
| | 1 | 7/8-14 | 3/4-16 | 1 1/8 | 1.499 | — | 1/2 | 7/8 | 15/16 | 1/2 | — | — | 2 5/16 | 1 | — | 6 7/8 | |
| 2 | 5/8 | 1/2-20 | 7/16-20 | 3/4 | 1.124 | 1.968 | 3/8 | 1/2 | 9/16 | — | 1/4 | 3/16 | 1 5/16 | 5/8 | 1 | 6 1/8 | |
| | 1 3/8 | 1 1/4-12 | 1-14 | 1 5/8 | 1.999 | — | 5/8 | 1 1/8 | 1 5/16 | 5/8 | — | — | 2 9/16 | 1 1/4 | — | 7 3/8 | |
| 2 1/2 | 1 | 7/8-14 | 3/4-16 | 1 1/8 | 1.499 | 2.468 | 1/2 | 7/8 | 15/16 | — | 1/4 | 3/8 | 2 5/16 | 1 | 1 3/8 | 6 7/8 | |
| | 5/8 | 1/2-20 | 7/16-20 | 3/4 | 1.124 | 1.968 | 3/8 | 1/2 | 9/16 | — | 1/4 | 3/16 | 1 5/16 | 5/8 | 1 | 6 1/4 | |
| 2 1/2 | 1 3/4 | 1 1/2-12 | 1 1/4-12 | 2 | 2.374 | — | 3/4 | 1 1/2 | 1 11/16 | 3/4 | — | — | 2 13/16 | 1 1/2 | — | 8 | |
| | 1 | 7/8-14 | 3/4-16 | 1 1/8 | 1.499 | 2.468 | 1/2 | 7/8 | 15/16 | — | 1/4 | 3/8 | 2 5/16 | 1 | 1 3/8 | 7 | |
| 3 1/4 | 1 3/8 | 1 1/4-12 | 1-14 | 1 5/8 | 1.999 | 2.968 | 5/8 | 1 1/8 | 1 5/16 | 5/8 | — | — | 2 9/16 | 1 1/4 | — | 7 1/2 | |
| | 1 | 7/8-14 | 3/4-16 | 1 1/8 | 1.499 | 2.468 | 1/2 | 7/8 | 15/16 | — | 1/4 | 3/8 | 2 7/16 | 3/4 | 1 3/8 | 7 1/2 | |
| 3 1/4 | 2 | 1 3/4-12 | 1 1/2-12 | 2 1/4 | 2.624 | 3.735 | 7/8 | 1 11/16 | 1 15/16 | — | 1/4 | 9/16 | 3 1/16 | 1 3/8 | 2 | 8 3/4 | |
| | 1 3/8 | 1 1/4-12 | 1-14 | 1 5/8 | 1.999 | 2.968 | 5/8 | 1 1/8 | 1 5/16 | — | 1/4 | 1/2 | 2 11/16 | 1 | 1 5/8 | 8 | |
| 3 1/4 | 1 3/4 | 1 1/2-12 | 1 1/4-12 | 2 | 2.374 | 3.625 | 3/4 | 1 1/2 | 1 11/16 | — | 1/4 | 9/16 | 2 15/16 | 1 1/4 | 1 7/8 | 8 1/2 | |
| | 1 | 7/8-14 | 3/4-16 | 1 1/8 | 1.499 | 2.468 | 1/2 | 7/8 | 15/16 | — | 1/4 | 3/8 | 2 7/16 | 3/4 | 1 3/8 | 7 1/2 | |
| 4 | 2 1/2 | 2 1/4-12 | 1 7/8-12 | 3 | 3.124 | 4.312 | 1 | 2 1/16 | 2 3/8 | — | 1/4 | 1 1/16 | 3 5/16 | 1 5/8 | 2 1/4 | 9 1/4 | |
| | 1 3/8 | 1 1/4-12 | 1-14 | 1 5/8 | 1.999 | 2.968 | 5/8 | 1 1/8 | 1 5/16 | — | 1/4 | 1/2 | 2 11/16 | 1 | 1 5/8 | 8 | |
| 4 | 1 3/4 | 1 1/2-12 | 1 1/4-12 | 2 | 2.374 | 3.625 | 3/4 | 1 1/2 | 1 11/16 | — | 1/4 | 9/16 | 2 15/16 | 1 1/4 | 1 7/8 | 8 1/2 | |
| | 2 | 1 3/4-12 | 1 1/2-12 | 2 1/4 | 2.624 | 3.735 | 7/8 | 1 11/16 | 1 15/16 | — | 1/4 | 9/16 | 3 1/16 | 1 3/8 | 2 | 8 3/4 | |
| 4 | 2 1/2 | 2 1/4-12 | 1 7/8-12 | 3 | 3.124 | 4.312 | 1 | 2 1/16 | 2 3/8 | — | 1/4 | 1 1/16 | 3 5/16 | 1 5/8 | 2 1/4 | 9 1/2 | |
| | 3 | 2 3/4-12 | 2 1/4-12 | 3 1/2 | 3.749 | — | 1 | 2 5/8 | 2 7/8 | 5/8 | — | — | 3 5/16 | 1 5/8 | — | 9 1/2 | |
| 5 | 1 3/8 | 1 1/4-12 | 1-14 | 1 5/8 | 1.999 | 2.968 | 5/8 | 1 1/8 | 1 5/16 | — | 1/4 | 7/16 | 2 13/16 | 7/8 | 1 5/8 | 8 3/4 | |
| | 3 1/2 | 3 1/4-12 | 2 1/2-12 | 3 1/2 | 4.249 | — | 1 | 3 | 3 3/8 | 5/8 | — | — | 3 5/16 | 1 5/8 | — | 9 1/2 | |
| 5 | 1 3/8 | 1 1/4-12 | 1-14 | 1 5/8 | 1.999 | 2.968 | 5/8 | 1 1/8 | 1 5/16 | — | 1/4 | 1/2 | 2 11/16 | 1 | 1 5/8 | 8 1/4 | |
| | 1 3/4 | 1 1/2-12 | 1 1/4-12 | 2 | 2.374 | 3.625 | 3/4 | 1 1/2 | 1 11/16 | — | 1/4 | 9/16 | 2 15/16 | 1 1/4 | 1 7/8 | 8 3/4 | |
| 5 | 2 | 1 3/4-12 | 1 1/2-12 | 2 1/4 | 2.624 | 3.735 | 7/8 | 1 11/16 | 1 15/16 | — | 1/4 | 9/16 | 3 1/16 | 1 3/8 | 2 | 9 | |
| | 2 1/2 | 2 1/4-12 | 1 7/8-12 | 3 | 3.124 | 4.312 | 1 | 2 1/16 | 2 3/8 | — | 1/4 | 1 1/16 | 3 5/16 | 1 5/8 | 2 1/4 | 9 1/2 | |
| 5 | 3 | 2 3/4-12 | 2 1/4-12 | 3 1/2 | 3.749 | — | 1 | 2 5/8 | 2 7/8 | 5/8 | — | — | 3 5/16 | 1 5/8 | — | 9 1/2 | |
| | 1 3/8 | 1 1/4-12 | 1-14 | 1 5/8 | 1.999 | 2.968 | 5/8 | 1 1/8 | 1 5/16 | — | 1/4 | 7/16 | 2 13/16 | 7/8 | 1 5/8 | 8 3/4 | |
| 6 | 4 | 3 3/4-12 | 3-12 | 4 | 4.749 | — | 1 | 3 3/8 | 3 7/8 | 1/2 | — | — | 3 7/16 | 1 1/2 | — | 10 | |
| | 1 3/4 | 1 1/2-12 | 1 1/4-12 | 2 | 2.374 | 3.625 | 3/4 | 1 1/2 | 1 11/16 | — | 1/4 | 9/16 | 3 1/16 | 1 1/8 | 1 7/8 | 9 1/4 | |
| 6 | 2 | 1 3/4-12 | 1 1/2-12 | 2 1/4 | 2.624 | 3.735 | 7/8 | 1 11/16 | 1 15/16 | — | 1/4 | 9/16 | 3 3/16 | 1 1/4 | 2 | 9 1/2 | |
| | 2 1/2 | 2 1/4-12 | 1 7/8-12 | 3 | 3.124 | 4.312 | 1 | 2 1/16 | 2 3/8 | — | 1/4 | 1 1/16 | 3 7/16 | 1 1/2 | 2 1/4 | 10 | |
| 6 | 3 | 2 3/4-12 | 2 1/4-12 | 3 1/2 | 3.749 | — | 1 | 2 5/8 | 2 7/8 | 1/2 | — | — | 3 7/16 | 1 1/2 | — | 10 | |
| | 3 1/2 | 3 1/4-12 | 2 1/2-12 | 3 1/2 | 4.249 | — | 1 | 3 | 3 3/8 | 1/2 | — | — | 3 7/16 | 1 1/2 | — | 10 | |

Miller AV Series Heavy-Duty Air Cylinders

Side Lug Mount – 7" to 14" Bore Sizes
Side Tap Mount – 7" to 14" Bore Sizes

Side Lug Mount Model 72 7" - 14" Bore

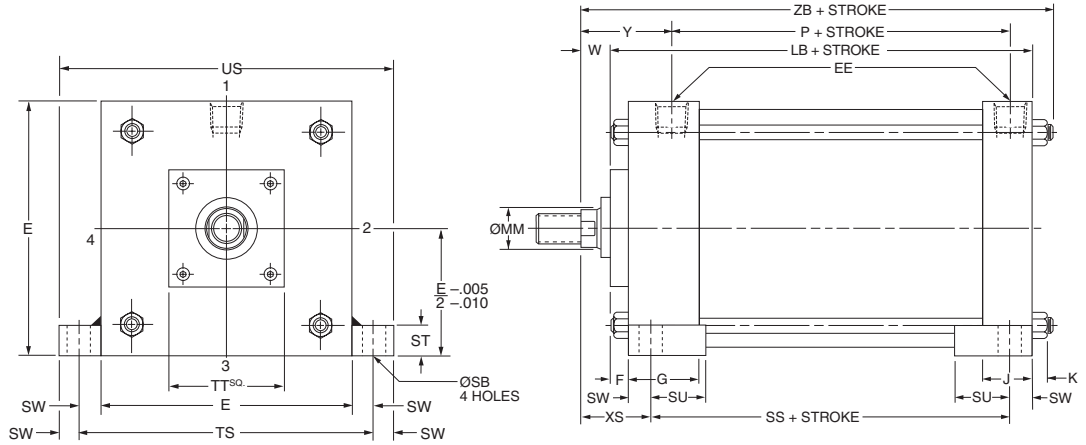
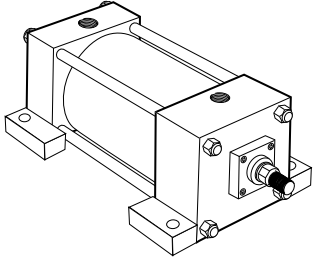

Side Tap Mount Model 74 7" - 14" Bore

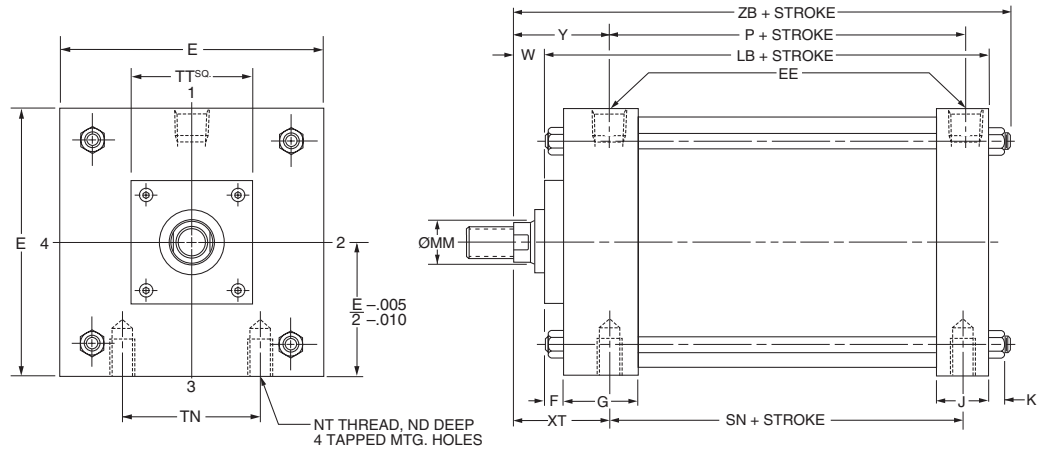
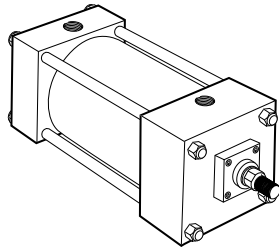

Rod End Dimensions — see table 2

Thread Style 2 Small Male

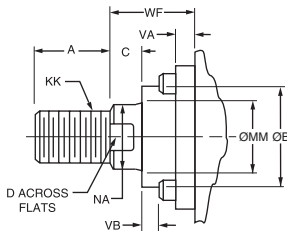

Thread Style 4 Short Female

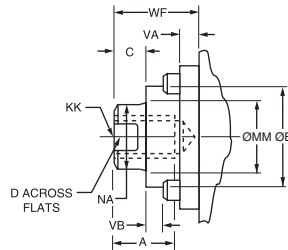

Thread Style 5 Intermediate Male

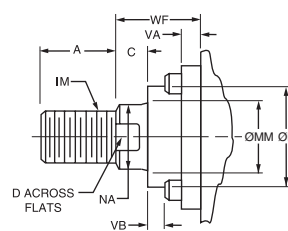

“Special” Thread Style X

Special thread, extension, rod eye, blank, etc., are also available.

To order, specify “Style X” and give desired dimensions for KK, A and WF. If otherwise special, furnish dimensioned sketch.

A high strength rod end stud is supplied on thread style 2 through 2" diameter rods and on thread style 5 through 1 3/8" diameter rods. Larger sizes or special rod ends are cut threads. Style 2 rod ends are recommended where the workpiece is secured against the rod shoulder. When the workpiece is not shouldered, style 2 rod ends

are recommended through 2" piston rod diameters and style 5 rod ends are recommended on larger diameters. Use style 4 for applications where female rod end threads are required. If rod end is not specified, style 2 will be supplied.

Miller AV Series Heavy-Duty Air Cylinders

Side Lug Mount – 7" to 14" Bore Sizes
Side Tap Mount – 7" to 14" Bore Sizes

Table 1—Envelope and Mounting Dimensions

| Bore | E | EE NPTF | F | G | J | K | ND | NT | SB* (Bolt) | ST | SU | SW | TN | TS | US | Add Stroke | | | |
|------|--------------------------------|-------------------------------|-----------------------------|-------------------------------|-------------------------------|-------------------------------|-------------------------------|----------------------------------|-------------------------------|-------------------------------|--------------------------------|-------------------------------|-------------------------------|--------------------------------|--------------------------------|-------------------------------|--------------------------------|-------------------------------|-------------------------------|
| | | | | | | | | | | | | | | | | LB | P | SN | SS |
| 7 | 7 ¹ / ₂ | ³ / ₄ | ³ / ₄ | 2 | 1 ¹ / ₂ | ⁹ / ₁₆ | 1 ¹ / ₈ | ³ / ₄ -10 | ³ / ₄ | 1 | 1 ⁹ / ₁₆ | ¹¹ / ₁₆ | 3 ¹ / ₂ | 8 ⁷ / ₈ | 10 ¹ / ₄ | 5 ⁷ / ₈ | 3 ¹ / ₄ | 3 ¹ / ₄ | 3 ³ / ₄ |
| 8 | 8 ¹ / ₂ | ³ / ₄ | ³ / ₄ | 2 | 1 ¹ / ₂ | ⁹ / ₁₆ | 1 ¹ / ₈ | ³ / ₄ -10 | ³ / ₄ | 1 | 1 ⁹ / ₁₆ | ¹¹ / ₁₆ | 4 ¹ / ₂ | 9 ⁷ / ₈ | 11 ¹ / ₄ | 5 ⁷ / ₈ | 3 ¹¹ / ₄ | 3 ¹ / ₄ | 3 ³ / ₄ |
| 10 | 10 ⁵ / ₈ | 1 | ³ / ₄ | 2 ¹ / ₄ | 2 | ¹¹ / ₁₆ | 1 ¹ / ₂ | 1-8 | 1 | 1 ¹ / ₄ | 2 | ⁷ / ₈ | 5 ¹ / ₂ | 12 ³ / ₈ | 14 ¹ / ₈ | 7 ¹ / ₈ | 4 ¹ / ₈ | 4 ¹ / ₈ | 4 ⁵ / ₈ |
| 12 | 12 ³ / ₄ | 1 | ³ / ₄ | 2 ¹ / ₄ | 2 | ¹¹ / ₁₆ | 1 ¹ / ₂ | 1-8 | 1 | 1 ¹ / ₄ | 2 | ⁷ / ₈ | 7 ¹ / ₄ | 14 ¹ / ₂ | 16 ¹ / ₄ | 7 ⁵ / ₈ | 4 ⁵ / ₈ | 4 ⁵ / ₈ | 5 ¹ / ₈ |
| 14 | 14 ³ / ₄ | 1 ¹ / ₄ | ³ / ₄ | 2 ³ / ₄ | 2 ¹ / ₄ | ³ / ₄ | 1 ⁷ / ₈ | 1 ¹ / ₄ -7 | 1 ¹ / ₄ | 1 ¹ / ₂ | 2 ¹ / ₂ | 1 ¹ / ₈ | 8 ³ / ₈ | 17 | 19 ¹ / ₄ | 8 ⁷ / ₈ | 5 ¹ / ₂ | 5 ¹ / ₂ | 5 ⁷ / ₈ |

*Mounting holes are ¹/₁₆" larger than bolt size listed.

Table 2—Rod End Dimensions and Envelope Dimensions Affected By Rod Size

| Bore | MM Rod Ø | Thread | | Rod End Dimensions and Envelope Dimensions Affected By Rod Size | | | | | | | | | | | | Add Stroke |
|-------------------------------|-----------------------------------|-----------------------------------|-----------------------------------|---|-----------------------|-------------------------------|---------------------------------|---------------------------------|-------------------------------|--------------------------------|---------------------------------|---------------------------------|---------------------------------|---------------------------------|---------------------------------|---------------------------------|
| | | Style 5 IM | Style 2 & 4 KK | A | B Ø +.000 -.002 | C | D | NA | TT | V | W | XS | XT | Y | ZB | |
| | | 7 | 1 ³ / ₈ | 1 ¹ / ₄ -12 | 1-14 | 1 ⁵ / ₈ | 1.999 | ⁵ / ₈ | 1 ¹ / ₈ | 1 ⁵ / ₁₆ | 4 | ¹ / ₄ | ⁷ / ₈ | 2 ⁵ / ₁₆ | 2 ¹³ / ₁₆ | 2 ¹³ / ₁₆ |
| | 1 ³ / ₄ | 1 ¹ / ₂ -12 | 1 ¹ / ₄ -12 | 2 | 2.374 | ³ / ₄ | 1 ¹ / ₂ | 1 ¹¹ / ₁₆ | 4 | ³ / ₈ | 1 ¹ / ₈ | 2 ⁹ / ₁₆ | 3 ¹ / ₁₆ | 3 ¹ / ₁₆ | 7 ⁹ / ₁₆ | |
| | 2 | 1 ³ / ₄ -12 | 1 ¹ / ₂ -12 | 2 ¹ / ₄ | 2.624 | ⁷ / ₈ | 1 ¹¹ / ₁₆ | 1 ¹⁵ / ₁₆ | 4 | ³ / ₈ | 1 ¹ / ₄ | 2 ¹¹ / ₁₆ | 3 ³ / ₁₆ | 3 ³ / ₁₆ | 7 ¹¹ / ₁₆ | |
| 8 | 1 ³ / ₈ | 1 ¹ / ₄ -12 | 1-14 | 1 ⁵ / ₈ | 1.999 | ⁵ / ₈ | 1 ¹ / ₈ | 1 ⁵ / ₁₆ | 4 | ¹ / ₄ | ⁷ / ₈ | 2 ⁵ / ₁₆ | 2 ¹³ / ₁₆ | 2 ¹³ / ₁₆ | 7 ⁵ / ₁₆ | |
| | 5 ¹ / ₂ | 5 ¹ / ₄ -12 | 4-12 | 5 ¹ / ₂ | 6.249 | 1 | 4 ⁵ / ₈ | 5 ³ / ₈ | 7 | ¹ / ₂ | 1 ¹ / ₂ | 2 ¹⁵ / ₁₆ | 3 ⁷ / ₁₆ | 3 ⁷ / ₁₆ | 7 ¹⁵ / ₁₆ | |
| | 1 ³ / ₄ | 1 ¹ / ₂ -12 | 1 ¹ / ₄ -12 | 2 | 2.374 | ³ / ₄ | 1 ¹ / ₂ | 1 ¹¹ / ₁₆ | 4 | ³ / ₈ | 1 ¹ / ₈ | 2 ⁹ / ₁₆ | 3 ¹ / ₁₆ | 3 ¹ / ₁₆ | 7 ⁹ / ₁₆ | |
| | 2 | 1 ³ / ₄ -12 | 1 ¹ / ₂ -12 | 2 ¹ / ₄ | 2.624 | ⁷ / ₈ | 1 ¹¹ / ₁₆ | 1 ¹⁵ / ₁₆ | 4 | ³ / ₈ | 1 ¹ / ₄ | 2 ¹¹ / ₁₆ | 3 ³ / ₁₆ | 3 ³ / ₁₆ | 7 ¹¹ / ₁₆ | |
| | 2 ¹ / ₂ | 2 ¹ / ₄ -12 | 1 ⁷ / ₈ -12 | 3 | 3.124 | 1 | 2 ¹ / ₁₆ | 2 ³ / ₈ | 4 | ¹ / ₂ | 1 ¹ / ₂ | 2 ¹⁵ / ₁₆ | 3 ⁷ / ₁₆ | 3 ⁷ / ₁₆ | 7 ¹⁵ / ₁₆ | |
| | 3 | 2 ³ / ₄ -12 | 2 ¹ / ₄ -12 | 3 ¹ / ₂ | 3.749 | 1 | 2 ⁵ / ₈ | 2 ⁷ / ₈ | 5 ¹ / ₂ | ¹ / ₂ | 1 ¹ / ₂ | 2 ¹⁵ / ₁₆ | 3 ⁷ / ₁₆ | 3 ⁷ / ₁₆ | 7 ¹⁵ / ₁₆ | |
| | 3 ¹ / ₂ | 3 ¹ / ₄ -12 | 2 ¹ / ₂ -12 | 3 ¹ / ₂ | 4.249 | 1 | 3 | 3 ³ / ₈ | 5 ¹ / ₂ | ¹ / ₂ | 1 ¹ / ₂ | 2 ¹⁵ / ₁₆ | 3 ⁷ / ₁₆ | 3 ⁷ / ₁₆ | 7 ¹⁵ / ₁₆ | |
| | 4 | 3 ³ / ₄ -12 | 3-12 | 4 | 4.749 | 1 | 3 ³ / ₈ | 3 ⁷ / ₈ | 5 ¹ / ₂ | ¹ / ₂ | 1 ¹ / ₂ | 2 ¹⁵ / ₁₆ | 3 ⁷ / ₁₆ | 3 ⁷ / ₁₆ | 7 ¹⁵ / ₁₆ | |
| 4 ¹ / ₂ | 4 ¹ / ₄ -12 | 3 ¹ / ₄ -12 | 4 ¹ / ₂ | 5.249 | 1 | 3 ⁷ / ₈ | 4 ³ / ₈ | 7 | ¹ / ₂ | 1 ¹ / ₂ | 2 ¹⁵ / ₁₆ | 3 ⁷ / ₁₆ | 3 ⁷ / ₁₆ | 7 ¹⁵ / ₁₆ | | |
| 5 | 4 ³ / ₄ -12 | 3 ¹ / ₂ -12 | 5 | 5.749 | 1 | 4 ¹ / ₄ | 4 ⁷ / ₈ | 7 | ¹ / ₂ | 1 ¹ / ₂ | 2 ¹⁵ / ₁₆ | 3 ⁷ / ₁₆ | 3 ⁷ / ₁₆ | 7 ¹⁵ / ₁₆ | | |
| 10 | 1 ³ / ₄ | 1 ¹ / ₂ -12 | 1 ¹ / ₄ -12 | 2 | 2.374 | ³ / ₄ | 1 ¹ / ₂ | 1 ¹¹ / ₁₆ | 4 | ³ / ₈ | 1 ¹ / ₈ | 2 ³ / ₄ | 3 ¹ / ₈ | 3 ¹ / ₈ | 8 ⁵ / ₁₆ | |
| | 2 | 1 ³ / ₄ -12 | 1 ¹ / ₂ -12 | 2 ¹ / ₄ | 2.624 | ⁷ / ₈ | 1 ¹¹ / ₁₆ | 1 ¹⁵ / ₁₆ | 4 | ³ / ₈ | 1 ¹ / ₄ | 2 ⁷ / ₈ | 3 ¹ / ₄ | 3 ¹ / ₄ | 9 ¹ / ₁₆ | |
| | 2 ¹ / ₂ | 2 ¹ / ₄ -12 | 1 ⁷ / ₈ -12 | 3 | 3.124 | 1 | 2 ¹ / ₁₆ | 2 ³ / ₈ | 4 | ¹ / ₂ | 1 ¹ / ₂ | 3 ¹ / ₈ | 3 ¹ / ₂ | 3 ¹ / ₂ | 9 ⁵ / ₁₆ | |
| | 3 | 2 ³ / ₄ -12 | 2 ¹ / ₄ -12 | 3 ¹ / ₂ | 3.749 | 1 | 2 ⁵ / ₈ | 2 ⁷ / ₈ | 5 ¹ / ₂ | ¹ / ₂ | 1 ¹ / ₂ | 3 ¹ / ₈ | 3 ¹ / ₂ | 3 ¹ / ₂ | 9 ⁵ / ₁₆ | |
| | 3 ¹ / ₂ | 3 ¹ / ₄ -12 | 2 ¹ / ₂ -12 | 3 ¹ / ₂ | 4.249 | 1 | 3 | 3 ³ / ₈ | 5 ¹ / ₂ | ¹ / ₂ | 1 ¹ / ₂ | 3 ¹ / ₈ | 3 ¹ / ₂ | 3 ¹ / ₂ | 9 ⁵ / ₁₆ | |
| | 4 | 3 ³ / ₄ -12 | 3-12 | 4 | 4.749 | 1 | 3 ³ / ₈ | 3 ⁷ / ₈ | 5 ¹ / ₂ | ¹ / ₂ | 1 ¹ / ₂ | 3 ¹ / ₈ | 3 ¹ / ₂ | 3 ¹ / ₂ | 9 ⁵ / ₁₆ | |
| | 4 ¹ / ₂ | 4 ¹ / ₄ -12 | 3 ¹ / ₄ -12 | 4 ¹ / ₂ | 5.249 | 1 | 3 ⁷ / ₈ | 4 ³ / ₈ | 7 | ¹ / ₂ | 1 ¹ / ₂ | 3 ¹ / ₈ | 3 ¹ / ₂ | 3 ¹ / ₂ | 9 ⁵ / ₁₆ | |
| | 5 | 4 ³ / ₄ -12 | 3 ¹ / ₂ -12 | 5 | 5.749 | 1 | 4 ¹ / ₄ | 4 ⁷ / ₈ | 7 | ¹ / ₂ | 1 ¹ / ₂ | 3 ¹ / ₈ | 3 ¹ / ₂ | 3 ¹ / ₂ | 9 ⁵ / ₁₆ | |
| 5 ¹ / ₂ | 5 ¹ / ₄ -12 | 4-12 | 5 ¹ / ₂ | 6.249 | 1 | 4 ⁵ / ₈ | 5 ³ / ₈ | 7 | ¹ / ₂ | 1 ¹ / ₂ | 3 ¹ / ₈ | 3 ¹ / ₂ | 3 ¹ / ₂ | 9 ⁵ / ₁₆ | | |
| 12 | 2 | 1 ³ / ₄ -12 | 1 ¹ / ₂ -12 | 2 ¹ / ₄ | 2.624 | ⁷ / ₈ | 1 ¹¹ / ₁₆ | 1 ¹⁵ / ₁₆ | 4 | ³ / ₈ | 1 ¹ / ₄ | 2 ⁷ / ₈ | 3 ¹ / ₄ | 3 ¹ / ₄ | 9 ¹ / ₁₆ | |
| | 2 ¹ / ₂ | 2 ¹ / ₄ -12 | 1 ⁷ / ₈ -12 | 3 | 3.124 | 1 | 2 ¹ / ₁₆ | 2 ³ / ₈ | 4 | ¹ / ₂ | 1 ¹ / ₂ | 3 ¹ / ₈ | 3 ¹ / ₂ | 3 ¹ / ₂ | 9 ¹³ / ₁₆ | |
| | 3 | 2 ³ / ₄ -12 | 2 ¹ / ₄ -12 | 3 ¹ / ₂ | 3.749 | 1 | 2 ⁵ / ₈ | 2 ⁷ / ₈ | 5 ¹ / ₂ | ¹ / ₂ | 1 ¹ / ₂ | 3 ¹ / ₈ | 3 ¹ / ₂ | 3 ¹ / ₂ | 9 ¹³ / ₁₆ | |
| | 3 ¹ / ₂ | 3 ¹ / ₄ -12 | 2 ¹ / ₂ -12 | 3 ¹ / ₂ | 4.249 | 1 | 3 | 3 ³ / ₈ | 5 ¹ / ₂ | ¹ / ₂ | 1 ¹ / ₂ | 3 ¹ / ₈ | 3 ¹ / ₂ | 3 ¹ / ₂ | 9 ¹³ / ₁₆ | |
| | 4 | 3 ³ / ₄ -12 | 3-12 | 4 | 4.749 | 1 | 3 ³ / ₈ | 3 ⁷ / ₈ | 5 ¹ / ₂ | ¹ / ₂ | 1 ¹ / ₂ | 3 ¹ / ₈ | 3 ¹ / ₂ | 3 ¹ / ₂ | 9 ¹³ / ₁₆ | |
| | 4 ¹ / ₂ | 4 ¹ / ₄ -12 | 3 ¹ / ₄ -12 | 4 ¹ / ₂ | 5.249 | 1 | 3 ⁷ / ₈ | 4 ³ / ₈ | 7 | ¹ / ₂ | 1 ¹ / ₂ | 3 ¹ / ₈ | 3 ¹ / ₂ | 3 ¹ / ₂ | 9 ¹³ / ₁₆ | |
| | 5 | 4 ³ / ₄ -12 | 3 ¹ / ₂ -12 | 5 | 5.749 | 1 | 4 ¹ / ₄ | 4 ⁷ / ₈ | 7 | ¹ / ₂ | 1 ¹ / ₂ | 3 ¹ / ₈ | 3 ¹ / ₂ | 3 ¹ / ₂ | 9 ¹³ / ₁₆ | |
| 5 ¹ / ₂ | 5 ¹ / ₄ -12 | 4-12 | 5 ¹ / ₂ | 6.249 | 1 | 4 ⁵ / ₈ | 5 ³ / ₈ | 7 | ¹ / ₂ | 1 ¹ / ₂ | 3 ¹ / ₈ | 3 ¹ / ₂ | 3 ¹ / ₂ | 9 ¹³ / ₁₆ | | |
| 14 | 2 ¹ / ₂ | 2 ¹ / ₄ -12 | 1 ⁷ / ₈ -12 | 3 | 3.124 | 1 | 2 ¹ / ₁₆ | 2 ³ / ₈ | 4 | ¹ / ₂ | 1 ¹ / ₂ | 3 ³ / ₈ | 3 ¹³ / ₁₆ | 3 ¹³ / ₁₆ | 11 ¹ / ₈ | |
| | 3 | 2 ³ / ₄ -12 | 2 ¹ / ₄ -12 | 3 ¹ / ₂ | 3.749 | 1 | 2 ⁵ / ₈ | 2 ⁷ / ₈ | 5 ¹ / ₂ | ¹ / ₂ | 1 ¹ / ₂ | 3 ³ / ₈ | 3 ¹³ / ₁₆ | 3 ¹³ / ₁₆ | 11 ¹ / ₈ | |
| | 3 ¹ / ₂ | 3 ¹ / ₄ -12 | 2 ¹ / ₂ -12 | 3 ¹ / ₂ | 4.249 | 1 | 3 | 3 ³ / ₈ | 5 ¹ / ₂ | ¹ / ₂ | 1 ¹ / ₂ | 3 ³ / ₈ | 3 ¹³ / ₁₆ | 3 ¹³ / ₁₆ | 11 ¹ / ₈ | |
| | 4 | 3 ³ / ₄ -12 | 3-12 | 4 | 4.749 | 1 | 3 ³ / ₈ | 3 ⁷ / ₈ | 5 ¹ / ₂ | ¹ / ₂ | 1 ¹ / ₂ | 3 ³ / ₈ | 3 ¹³ / ₁₆ | 3 ¹³ / ₁₆ | 11 ¹ / ₈ | |
| | 4 ¹ / ₂ | 4 ¹ / ₄ -12 | 3 ¹ / ₄ -12 | 4 ¹ / ₂ | 5.249 | 1 | 3 ⁷ / ₈ | 4 ³ / ₈ | 7 | ¹ / ₂ | 1 ¹ / ₂ | 3 ³ / ₈ | 3 ¹³ / ₁₆ | 3 ¹³ / ₁₆ | 11 ¹ / ₈ | |
| | 5 | 4 ³ / ₄ -12 | 3 ¹ / ₂ -12 | 5 | 5.749 | 1 | 4 ¹ / ₄ | 4 ⁷ / ₈ | 7 | ¹ / ₂ | 1 ¹ / ₂ | 3 ³ / ₈ | 3 ¹³ / ₁₆ | 3 ¹³ / ₁₆ | 11 ¹ / ₈ | |
| 5 ¹ / ₂ | 5 ¹ / ₄ -12 | 4-12 | 5 ¹ / ₂ | 6.249 | 1 | 4 ⁵ / ₈ | 5 ³ / ₈ | 7 | ¹ / ₂ | 1 ¹ / ₂ | 3 ³ / ₈ | 3 ¹³ / ₁₆ | 3 ¹³ / ₁₆ | 11 ¹ / ₈ | | |

* Mounting style MS1 not offered in this rod size.

Miller AV Series Heavy-Duty Air Cylinders

Head Square Mount
Cap Square Mount
7" to 14" Bore Sizes

Head Square Mount Model 63 7" - 14" Bore

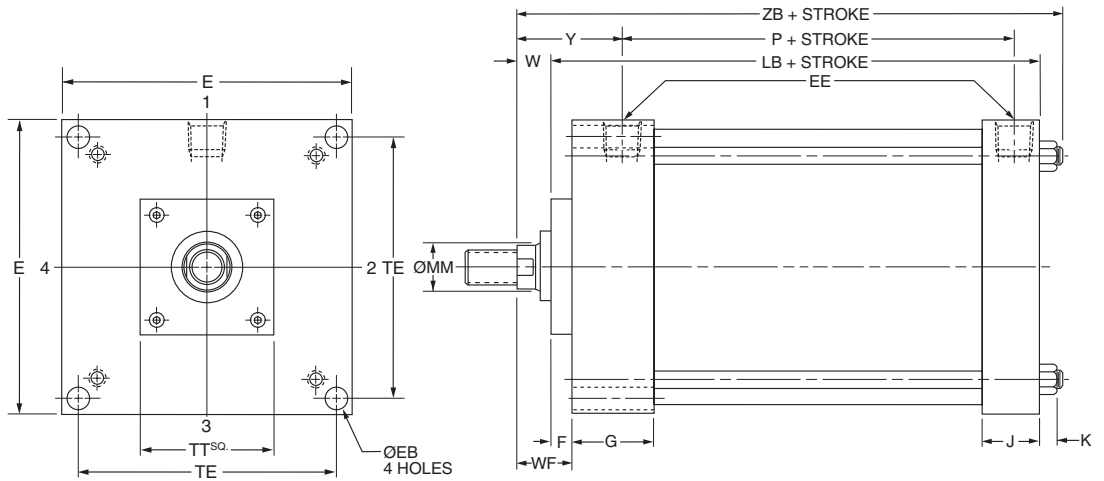
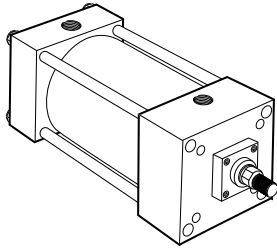

Cap Square Mount Model 64 7" - 14" Bore

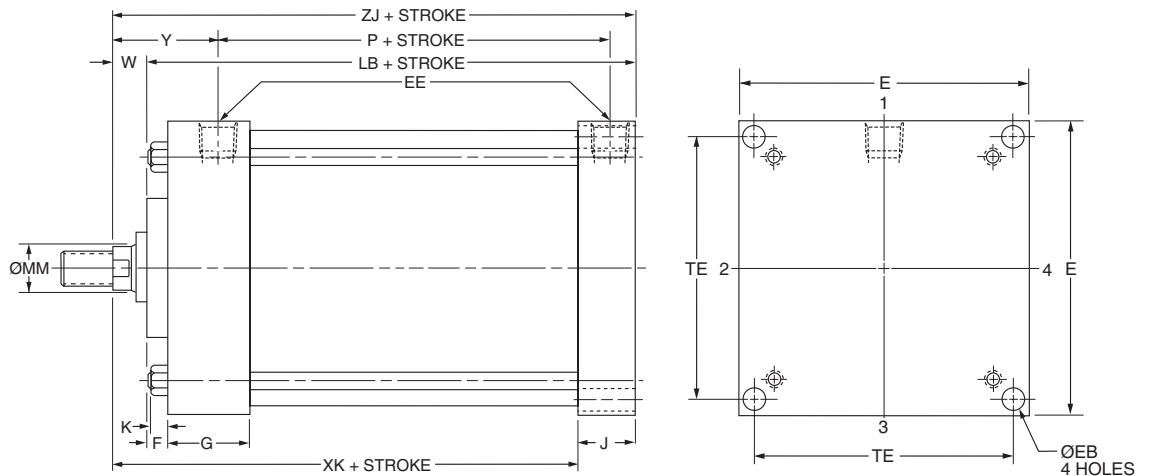
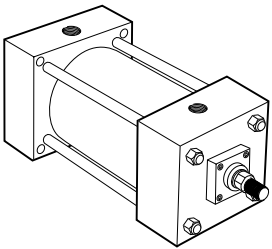

Rod End Dimensions — see table 2

Thread Style 2 Small Male

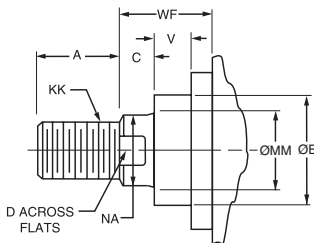

Thread Style 4 Short Female

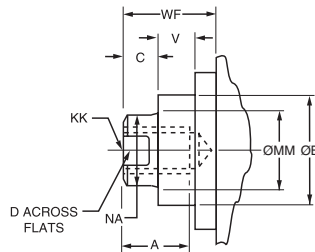

Thread Style 5 Intermediate Male

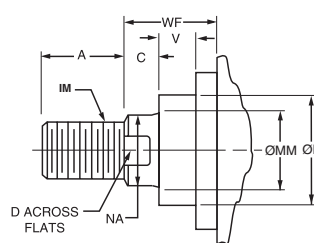

“Special” Thread Style X

Special thread, extension, rod eye, blank, etc., are also available.

To order, specify “Style X” and give desired dimensions for KK , A and WF . If otherwise special, furnish dimensioned sketch.

A high strength rod end stud is supplied on thread style 2 through 2" diameter rods and on thread style 5 through 1 3/8" diameter rods. Larger sizes or special rod ends are cut threads. Style 2 rod ends are recommended where the workpiece is secured against the rod shoulder. When the workpiece is not shouldered, style 2 rod ends

are recommended through 2" piston rod diameters and style 5 rod ends are recommended on larger diameters. Use style 4 for applications where female rod end threads are required. If rod end is not specified, style 2 will be supplied.

Miller AV Series Heavy-Duty Air Cylinders

Head Square Mount
Cap Square Mount
7" to 14" Bore Sizes

Table 1—Envelope and Mounting Dimensions

| Bore | E | EB* (Bolt) | EE NPTF | F | G | J | K | TE | Add Stroke | |
|------|--------------------------------|-------------------------------|-------------------------------|-------------------------------|-------------------------------|-------------------------------|---------------------------------|-------|-------------------------------|-------------------------------|
| | | | | | | | | | LB | P |
| 7 | 7 ¹ / ₂ | 1 ¹ / ₂ | 3 ³ / ₄ | 3 ³ / ₄ | 2 | 1 ¹ / ₂ | 9 ⁹ / ₁₆ | 6.75 | 5 ⁵ / ₈ | 3 ³ / ₄ |
| 8 | 8 ¹ / ₂ | 5 ⁵ / ₈ | 3 ³ / ₄ | 3 ³ / ₄ | 2 | 1 ¹ / ₂ | 9 ⁹ / ₁₆ | 7.57 | 5 ⁵ / ₈ | 3 ³ / ₄ |
| 10 | 10 ⁵ / ₈ | 3 ³ / ₄ | 1 | 3 ³ / ₄ | 2 ¹ / ₄ | 2 | 1 ¹¹ / ₁₆ | 9.40 | 7 ⁷ / ₈ | 4 ⁴ / ₈ |
| 12 | 12 ³ / ₄ | 3 ³ / ₄ | 1 | 3 ³ / ₄ | 2 ¹ / ₄ | 2 | 1 ¹¹ / ₁₆ | 11.10 | 7 ⁵ / ₈ | 4 ⁵ / ₈ |
| 14 | 14 ³ / ₄ | 7 ⁷ / ₈ | 1 ¹ / ₄ | 3 ³ / ₄ | 2 ³ / ₄ | 2 ¹ / ₄ | 3 ³ / ₄ | 12.87 | 8 ⁷ / ₈ | 5 ¹ / ₂ |

*Mounting holes are 1/16" larger than bolt size listed.

Table 2—Rod End Dimensions and Envelope Dimensions Affected By Rod Size

| Bore | MM Rod Ø | Thread | | Rod End Dimensions and Envelope Dimensions Affected By Rod Size | | | | | | | | | | | | | Add Stroke ZJ |
|------|-------------------------------|-----------------------------------|-----------------------------------|---|-----------------------|-------------------------------|---------------------------------|---------------------------------|-------------------------------|-------------------------------|-------------------------------|-------------------------------|-------------------------------|---------------------------------|---------------------------------|--------------------------------|------------------|
| | | Style 5 IM | Style 2 & 4 KK | A | B Ø +.000 -.002 | C | D | NA | TT | V | W | WF | XK | Y | ZB | | |
| | | | | | | | | | | | | | | | | Z | |
| 7 | 1 ³ / ₈ | 1 ¹ / ₄ -12 | 1-14 | 1 ⁵ / ₈ | 1.999 | 5 ⁵ / ₈ | 1 ¹ / ₈ | 1 ⁵ / ₁₆ | 4 | 1 ¹ / ₄ | 7 ⁷ / ₈ | 1 ⁵ / ₈ | 5 ¹ / ₄ | 2 ¹³ / ₁₆ | 7 ⁵ / ₁₆ | 6 ³ / ₄ | |
| | 1 ³ / ₄ | 1 ¹ / ₂ -12 | 1 ¹ / ₄ -12 | 2 | 2.374 | 3 ³ / ₄ | 1 ¹ / ₂ | 1 ¹¹ / ₁₆ | 4 | 3 ³ / ₈ | 1 ¹ / ₈ | 1 ⁷ / ₈ | 5 ¹ / ₂ | 3 ¹ / ₁₆ | 7 ⁹ / ₁₆ | 7 | |
| | 2 | 1 ³ / ₄ -12 | 1 ¹ / ₂ -12 | 2 ¹ / ₄ | 2.624 | 7 ⁷ / ₈ | 1 ¹¹ / ₁₆ | 1 ¹⁵ / ₁₆ | 4 | 3 ³ / ₈ | 1 ¹ / ₄ | 2 | 5 ⁷ / ₈ | 3 ³ / ₁₆ | 7 ¹¹ / ₁₆ | 7 ¹ / ₈ | |
| 8 | 1 ³ / ₈ | 1 ¹ / ₄ -12 | 1-14 | 1 ⁵ / ₈ | 1.999 | 5 ⁵ / ₈ | 1 ¹ / ₈ | 1 ⁵ / ₁₆ | 4 | 1 ¹ / ₄ | 7 ⁷ / ₈ | 1 ⁵ / ₈ | 5 ¹ / ₄ | 2 ¹³ / ₁₆ | 7 ⁵ / ₁₆ | 6 ³ / ₄ | |
| | 5 ¹ / ₂ | 5 ¹ / ₄ -12 | 4-12 | 5 ¹ / ₂ | 6.249 | 1 | 4 ⁵ / ₈ | 5 ³ / ₈ | 7 | 1 ¹ / ₂ | 1 ¹ / ₂ | 2 ¹ / ₄ | 5 ⁷ / ₈ | 3 ⁷ / ₁₆ | 7 ¹⁵ / ₁₆ | 7 ³ / ₈ | |
| | 1 ³ / ₄ | 1 ¹ / ₂ -12 | 1 ¹ / ₄ -12 | 2 | 2.374 | 3 ³ / ₄ | 1 ¹ / ₂ | 1 ¹¹ / ₁₆ | 4 | 3 ³ / ₈ | 1 ¹ / ₈ | 1 ⁷ / ₈ | 5 ¹ / ₂ | 3 ¹ / ₁₆ | 7 ⁹ / ₁₆ | 7 | |
| | 2 | 1 ³ / ₄ -12 | 1 ¹ / ₂ -12 | 2 ¹ / ₄ | 2.624 | 7 ⁷ / ₈ | 1 ¹¹ / ₁₆ | 1 ¹⁵ / ₁₆ | 4 | 3 ³ / ₈ | 1 ¹ / ₄ | 2 | 5 ⁵ / ₈ | 3 ³ / ₁₆ | 7 ¹¹ / ₁₆ | 7 ¹ / ₈ | |
| | 2 ¹ / ₂ | 2 ¹ / ₄ -12 | 1 ⁷ / ₈ -12 | 3 | 3.124 | 1 | 2 ¹ / ₁₆ | 2 ³ / ₈ | 4 | 1 ¹ / ₂ | 1 ¹ / ₂ | 2 ¹ / ₄ | 5 ⁷ / ₈ | 3 ⁷ / ₁₆ | 7 ¹⁵ / ₁₆ | 7 ³ / ₈ | |
| | 3 | 2 ³ / ₄ -12 | 2 ¹ / ₄ -12 | 3 ¹ / ₂ | 3.749 | 1 | 2 ⁵ / ₈ | 2 ⁷ / ₈ | 5 ¹ / ₂ | 1 ¹ / ₂ | 1 ¹ / ₂ | 2 ¹ / ₄ | 5 ⁷ / ₈ | 3 ⁷ / ₁₆ | 7 ¹⁵ / ₁₆ | 7 ³ / ₈ | |
| | 3 ¹ / ₂ | 3 ¹ / ₄ -12 | 2 ¹ / ₂ -12 | 3 ¹ / ₂ | 4.249 | 1 | 3 | 3 ³ / ₈ | 5 ¹ / ₂ | 1 ¹ / ₂ | 1 ¹ / ₂ | 2 ¹ / ₄ | 5 ⁷ / ₈ | 3 ⁷ / ₁₆ | 7 ¹⁵ / ₁₆ | 7 ³ / ₈ | |
| | 4 | 3 ³ / ₄ -12 | 3-12 | 4 | 4.749 | 1 | 3 ³ / ₈ | 3 ⁷ / ₈ | 5 ¹ / ₂ | 1 ¹ / ₂ | 1 ¹ / ₂ | 2 ¹ / ₄ | 5 ⁷ / ₈ | 3 ⁷ / ₁₆ | 7 ¹⁵ / ₁₆ | 7 ³ / ₈ | |
| 10 | 1 ³ / ₄ | 1 ¹ / ₂ -12 | 1 ¹ / ₄ -12 | 2 | 2.374 | 3 ³ / ₄ | 1 ¹ / ₂ | 1 ¹¹ / ₁₆ | 4 | 3 ³ / ₈ | 1 ¹ / ₈ | 1 ⁷ / ₈ | 6 ¹ / ₄ | 3 ¹ / ₈ | 8 ¹⁵ / ₁₆ | 8 ¹ / ₄ | |
| | 2 | 1 ³ / ₄ -12 | 1 ¹ / ₂ -12 | 2 ¹ / ₄ | 2.624 | 7 ⁷ / ₈ | 1 ¹¹ / ₁₆ | 1 ¹⁵ / ₁₆ | 4 | 3 ³ / ₈ | 1 ¹ / ₄ | 2 | 6 ³ / ₈ | 3 ¹ / ₄ | 9 ¹ / ₁₆ | 8 ³ / ₈ | |
| | 2 ¹ / ₂ | 2 ¹ / ₄ -12 | 1 ⁷ / ₈ -12 | 3 | 3.124 | 1 | 2 ¹ / ₁₆ | 2 ³ / ₈ | 4 | 1 ¹ / ₂ | 1 ¹ / ₂ | 2 ¹ / ₄ | 6 ⁵ / ₈ | 3 ¹ / ₂ | 9 ⁵ / ₁₆ | 8 ⁵ / ₈ | |
| | 3 | 2 ³ / ₄ -12 | 2 ¹ / ₄ -12 | 3 ¹ / ₂ | 3.749 | 1 | 2 ⁵ / ₈ | 2 ⁷ / ₈ | 5 ¹ / ₂ | 1 ¹ / ₂ | 1 ¹ / ₂ | 2 ¹ / ₄ | 6 ⁵ / ₈ | 3 ¹ / ₂ | 9 ⁵ / ₁₆ | 8 ⁵ / ₈ | |
| | 3 ¹ / ₂ | 3 ¹ / ₄ -12 | 2 ¹ / ₂ -12 | 3 ¹ / ₂ | 4.249 | 1 | 3 | 3 ³ / ₈ | 5 ¹ / ₂ | 1 ¹ / ₂ | 1 ¹ / ₂ | 2 ¹ / ₄ | 6 ⁵ / ₈ | 3 ¹ / ₂ | 9 ⁵ / ₁₆ | 8 ⁵ / ₈ | |
| | 4 | 3 ³ / ₄ -12 | 3-12 | 4 | 4.749 | 1 | 3 ³ / ₈ | 3 ⁷ / ₈ | 5 ¹ / ₂ | 1 ¹ / ₂ | 1 ¹ / ₂ | 2 ¹ / ₄ | 6 ⁵ / ₈ | 3 ¹ / ₂ | 9 ⁵ / ₁₆ | 8 ⁵ / ₈ | |
| | 4 ¹ / ₂ | 4 ¹ / ₄ -12 | 3 ¹ / ₄ -12 | 4 ¹ / ₂ | 5.249 | 1 | 3 ⁷ / ₈ | 4 ³ / ₈ | 7 | 1 ¹ / ₂ | 1 ¹ / ₂ | 2 ¹ / ₄ | 6 ⁵ / ₈ | 3 ¹ / ₂ | 9 ⁵ / ₁₆ | 8 ⁵ / ₈ | |
| | 5 | 4 ³ / ₄ -12 | 3 ¹ / ₂ -12 | 5 | 5.749 | 1 | 4 ¹ / ₄ | 4 ⁷ / ₈ | 7 | 1 ¹ / ₂ | 1 ¹ / ₂ | 2 ¹ / ₄ | 6 ⁵ / ₈ | 3 ¹ / ₂ | 9 ⁵ / ₁₆ | 8 ⁵ / ₈ | |
| 12 | 2 | 1 ³ / ₄ -12 | 1 ¹ / ₂ -12 | 2 ¹ / ₄ | 2.624 | 7 ⁷ / ₈ | 1 ¹¹ / ₁₆ | 1 ¹⁵ / ₁₆ | 4 | 3 ³ / ₈ | 1 ¹ / ₄ | 2 | 6 ⁷ / ₈ | 3 ¹ / ₄ | 9 ⁹ / ₁₆ | 8 ⁷ / ₈ | |
| | 2 ¹ / ₂ | 2 ¹ / ₄ -12 | 1 ⁷ / ₈ -12 | 3 | 3.124 | 1 | 2 ¹ / ₁₆ | 2 ³ / ₈ | 4 | 1 ¹ / ₂ | 1 ¹ / ₂ | 2 ¹ / ₄ | 7 ¹ / ₈ | 3 ¹ / ₂ | 9 ¹³ / ₁₆ | 9 ¹ / ₈ | |
| | 3 | 2 ³ / ₄ -12 | 2 ¹ / ₄ -12 | 3 ¹ / ₂ | 3.749 | 1 | 2 ⁵ / ₈ | 2 ⁷ / ₈ | 5 ¹ / ₂ | 1 ¹ / ₂ | 1 ¹ / ₂ | 2 ¹ / ₄ | 7 ¹ / ₈ | 3 ¹ / ₂ | 9 ¹³ / ₁₆ | 9 ¹ / ₈ | |
| | 3 ¹ / ₂ | 3 ¹ / ₄ -12 | 2 ¹ / ₂ -12 | 3 ¹ / ₂ | 4.249 | 1 | 3 | 3 ³ / ₈ | 5 ¹ / ₂ | 1 ¹ / ₂ | 1 ¹ / ₂ | 2 ¹ / ₄ | 7 ¹ / ₈ | 3 ¹ / ₂ | 9 ¹³ / ₁₆ | 9 ¹ / ₈ | |
| | 4 | 3 ³ / ₄ -12 | 3-12 | 4 | 4.749 | 1 | 3 ³ / ₈ | 3 ⁷ / ₈ | 5 ¹ / ₂ | 1 ¹ / ₂ | 1 ¹ / ₂ | 2 ¹ / ₄ | 7 ¹ / ₈ | 3 ¹ / ₂ | 9 ¹³ / ₁₆ | 9 ¹ / ₈ | |
| | 4 ¹ / ₂ | 4 ¹ / ₄ -12 | 3 ¹ / ₄ -12 | 4 ¹ / ₂ | 5.249 | 1 | 3 ⁷ / ₈ | 4 ³ / ₈ | 7 | 1 ¹ / ₂ | 1 ¹ / ₂ | 2 ¹ / ₄ | 7 ¹ / ₈ | 3 ¹ / ₂ | 9 ¹³ / ₁₆ | 9 ¹ / ₈ | |
| | 5 | 4 ³ / ₄ -12 | 3 ¹ / ₂ -12 | 5 | 5.749 | 1 | 4 ¹ / ₄ | 4 ⁷ / ₈ | 7 | 1 ¹ / ₂ | 1 ¹ / ₂ | 2 ¹ / ₄ | 7 ¹ / ₈ | 3 ¹ / ₂ | 9 ¹³ / ₁₆ | 9 ¹ / ₈ | |
| | 5 ¹ / ₂ | 5 ¹ / ₄ -12 | 4-12 | 5 ¹ / ₂ | 6.249 | 1 | 4 ⁵ / ₈ | 5 ³ / ₈ | 7 | 1 ¹ / ₂ | 1 ¹ / ₂ | 2 ¹ / ₄ | 7 ¹ / ₈ | 3 ¹ / ₂ | 9 ¹³ / ₁₆ | 9 ¹ / ₈ | |
| 14 | 2 ¹ / ₂ | 2 ¹ / ₄ -12 | 1 ⁷ / ₈ -12 | 3 | 3.124 | 1 | 2 ¹ / ₁₆ | 2 ³ / ₈ | 4 | 1 ¹ / ₂ | 1 ¹ / ₂ | 2 ¹ / ₄ | 8 ¹ / ₈ | 3 ¹³ / ₁₆ | 11 ¹ / ₈ | 10 ³ / ₈ | |
| | 3 | 2 ³ / ₄ -12 | 2 ¹ / ₄ -12 | 3 ¹ / ₂ | 3.749 | 1 | 2 ⁵ / ₈ | 2 ⁷ / ₈ | 5 ¹ / ₂ | 1 ¹ / ₂ | 1 ¹ / ₂ | 2 ¹ / ₄ | 8 ¹ / ₈ | 3 ¹³ / ₁₆ | 11 ¹ / ₈ | 10 ³ / ₈ | |
| | 3 ¹ / ₂ | 3 ¹ / ₄ -12 | 2 ¹ / ₂ -12 | 3 ¹ / ₂ | 4.249 | 1 | 3 | 3 ³ / ₈ | 5 ¹ / ₂ | 1 ¹ / ₂ | 1 ¹ / ₂ | 2 ¹ / ₄ | 8 ¹ / ₈ | 3 ¹³ / ₁₆ | 11 ¹ / ₈ | 10 ³ / ₈ | |
| | 4 | 3 ³ / ₄ -12 | 3-12 | 4 | 4.749 | 1 | 3 ³ / ₈ | 3 ⁷ / ₈ | 5 ¹ / ₂ | 1 ¹ / ₂ | 1 ¹ / ₂ | 2 ¹ / ₄ | 8 ¹ / ₈ | 3 ¹³ / ₁₆ | 11 ¹ / ₈ | 10 ³ / ₈ | |
| | 4 ¹ / ₂ | 4 ¹ / ₄ -12 | 3 ¹ / ₄ -12 | 4 ¹ / ₂ | 5.249 | 1 | 3 ⁷ / ₈ | 4 ³ / ₈ | 7 | 1 ¹ / ₂ | 1 ¹ / ₂ | 2 ¹ / ₄ | 8 ¹ / ₈ | 3 ¹³ / ₁₆ | 11 ¹ / ₈ | 10 ³ / ₈ | |
| | 5 | 4 ³ / ₄ -12 | 3 ¹ / ₂ -12 | 5 | 5.749 | 1 | 4 ¹ / ₄ | 4 ⁷ / ₈ | 7 | 1 ¹ / ₂ | 1 ¹ / ₂ | 2 ¹ / ₄ | 8 ¹ / ₈ | 3 ¹³ / ₁₆ | 11 ¹ / ₈ | 10 ³ / ₈ | |
| | 5 ¹ / ₂ | 5 ¹ / ₄ -12 | 4-12 | 5 ¹ / ₂ | 6.249 | 1 | 4 ⁵ / ₈ | 5 ³ / ₈ | 7 | 1 ¹ / ₂ | 1 ¹ / ₂ | 2 ¹ / ₄ | 8 ¹ / ₈ | 3 ¹³ / ₁₆ | 11 ¹ / ₈ | 10 ³ / ₈ | |

Miller AV Series Heavy-Duty Air Cylinders

Head Trunnion Mount and Cap Trunnion Mount – 7" to 14" Bore Sizes
Intermediate Trunnion Mount – 8" to 14" Bore Sizes

Head Trunnion Mount Model 81 7" - 14" Bore

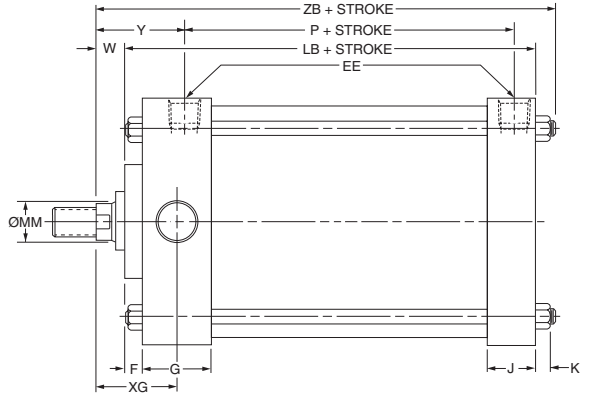
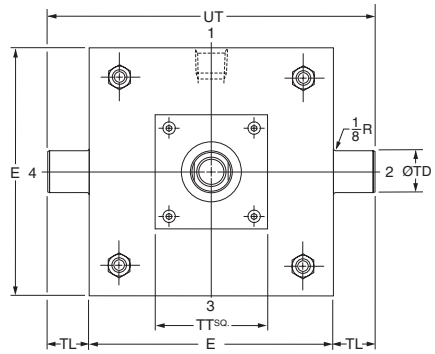
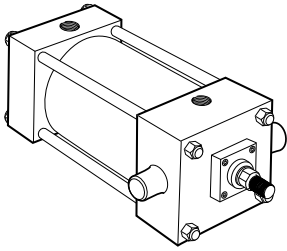

Cap Trunnion Mount Model 82 7" - 14" Bore

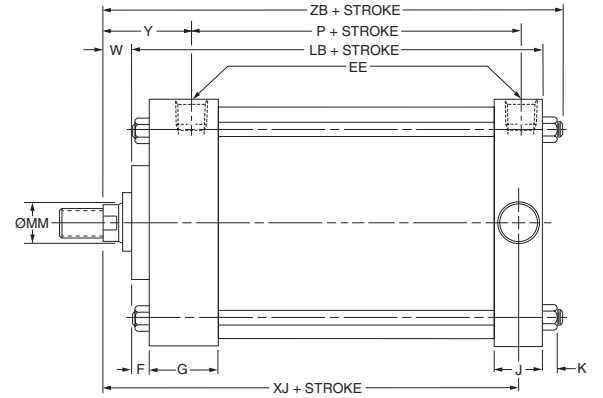
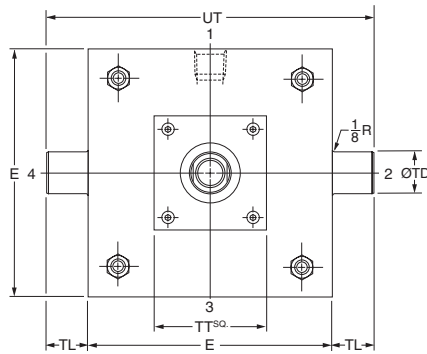
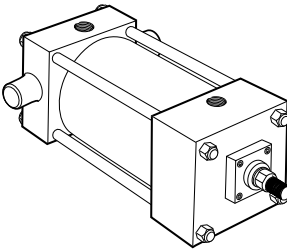

Intermediate Trunnion Mount Model 89 8" - 14" Bore

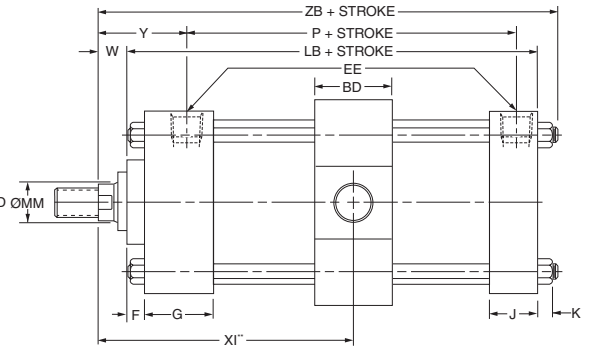
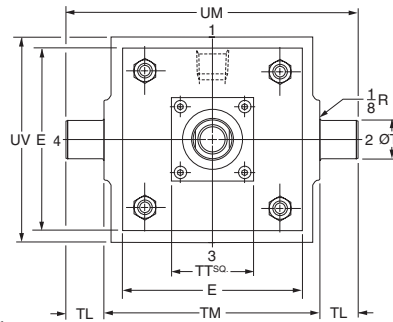
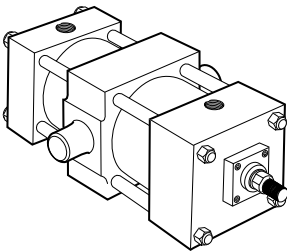

**Dimension "XI" to be specified by customer.

Rod End Dimensions — see table 2

Thread Style 2 Small Male

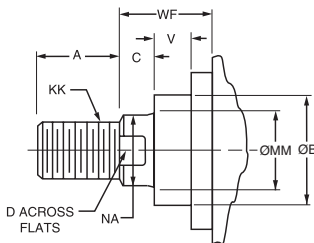

Thread Style 4 Short Female

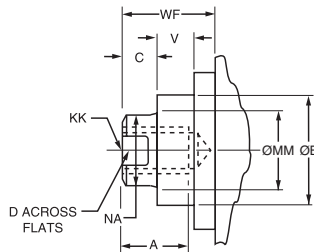

Thread Style 5 Intermediate Male

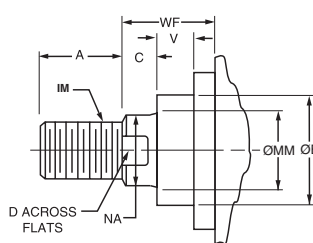

"Special" Thread Style X

Special thread, extension, rod eye, blank, etc., are also available.

To order, specify "Style X" and give desired dimensions for KK, A and WF. If otherwise special, furnish dimensioned sketch.

A high strength rod end stud is supplied on thread style 2 through 2" diameter rods and on thread style 5 through 1 3/8" diameter rods. Larger sizes or special rod ends are cut threads. Style 2 rod ends are recommended where the workpiece is secured against the rod shoulder. When the workpiece is not shouldered, style 2 rod ends

are recommended through 2" piston rod diameters and style 5 rod ends are recommended on larger diameters. Use style 4 for applications where female rod end threads are required. If rod end is not specified, style 2 will be supplied.

Miller AV Series Heavy-Duty Air Cylinders

Head Trunnion Mount and Cap Trunnion Mount – 7" to 14" Bore Sizes
Intermediate Trunnion Mount – 8" to 14" Bore Sizes

Table 1—Envelope and Mounting Dimensions

| Bore | BD | E | EE NPTF | F | G | J | K | TD Ø +0.000 -0.001 | TL | TM | UT | UM | UV | Add Stroke | |
|------|-------------------------------|--------------------------------|-------------------------------|-----------------------------|-------------------------------|-------------------------------|-------------------------------|--------------------------|-------------------------------|--------------------------------|--------------------------------|--------------------------------|--------------------------------|-------------------------------|-------------------------------|
| | | | | | | | | | | | | | | LB | P |
| 7 | — | 7 ¹ / ₂ | ³ / ₄ | ³ / ₄ | 2 | 1 ¹ / ₂ | ⁹ / ₁₆ | 1.375 | 1 ³ / ₈ | — | 10 ¹ / ₄ | — | — | 5 ⁷ / ₈ | 3 ³ / ₄ |
| 8 | 2 ¹ / ₂ | 8 ¹ / ₂ | ³ / ₄ | ³ / ₄ | 2 | 1 ¹ / ₂ | ⁴⁹ / ₆₄ | 1.375 | 1 ³ / ₈ | 9 ³ / ₄ | 11 ¹ / ₄ | 12 ¹ / ₂ | 9 ¹ / ₂ | 5 ⁷ / ₈ | 3 ³ / ₄ |
| 10 | 3 | 10 ⁵ / ₈ | 1 | ³ / ₄ | 2 ¹ / ₄ | 2 | ⁴⁹ / ₆₄ | 1.750 | 1 ³ / ₄ | 12 | 14 ¹ / ₈ | 15 ¹ / ₂ | 11 ³ / ₄ | 7 ¹ / ₈ | 4 ¹ / ₈ |
| 12 | 3 | 12 ³ / ₄ | 1 | ³ / ₄ | 2 ¹ / ₄ | 2 | ⁵⁷ / ₆₄ | 1.750 | 1 ³ / ₄ | 14 | 16 ¹ / ₄ | 17 ¹ / ₂ | 13 ³ / ₄ | 7 ⁵ / ₈ | 4 ⁵ / ₈ |
| 14 | 3 ¹ / ₂ | 14 ³ / ₄ | 1 ¹ / ₄ | ³ / ₄ | 2 ³ / ₄ | 2 ¹ / ₄ | 1 | 2.000 | 2 | 16 ¹ / ₄ | 18 ³ / ₄ | 20 ¹ / ₄ | 16 | 8 ⁷ / ₈ | 5 ¹ / ₂ |

Table 2—Rod End Dimensions and Envelope Dimensions Affected By Rod Size

| Bore | MM Rod Ø | Thread | | Rod End Dimensions and Envelope Dimensions Affected By Rod Size | | | | | | | | | | | | | | Add Stroke | |
|-------------------------------|-----------------------------------|-----------------------------------|-----------------------------------|---|-------------------------|-------------------------------|---------------------------------|---------------------------------|-------------------------------|-------------------------------|-------------------------------|---------------------------------|---------------------------------|---------------------------------|---------------------------------|---------------------------------|--|------------|--|
| | | Style 5 IM | Style 2 & 4 KK | A | B Ø +0.000 -0.002 | C | D | NA | TT | V | W | XG | XI** (Min.) | Y | XJ | ZB | | | |
| | | | | | | | | | | | | | | | | | | | |
| 7 | 1 ³ / ₈ | 1 ¹ / ₂ -12 | 1-14 | 1 ⁵ / ₈ | 1.999 | ⁵ / ₈ | 1 ¹ / ₈ | 1 ⁵ / ₁₆ | 4 | ¹ / ₄ | ⁷ / ₈ | 2 ⁵ / ₈ | — | 2 ¹³ / ₁₆ | 6 | 7 ⁵ / ₁₆ | | | |
| | 1 ³ / ₄ | 1 ¹ / ₂ -12 | 1 ¹ / ₄ -12 | 2 | 2.374 | ³ / ₄ | 1 ¹ / ₂ | 1 ¹¹ / ₁₆ | 4 | ³ / ₈ | 1 ¹ / ₈ | 2 ⁷ / ₈ | — | 3 ¹ / ₁₆ | 6 ¹ / ₄ | 7 ⁹ / ₁₆ | | | |
| | 2 | 1 ³ / ₄ -12 | 1 ¹ / ₂ -12 | 2 ¹ / ₄ | 2.624 | ⁷ / ₈ | 1 ¹¹ / ₁₆ | 1 ¹⁵ / ₁₆ | 4 | ³ / ₈ | 1 ¹ / ₄ | 3 | — | 3 ³ / ₁₆ | 6 ³ / ₈ | 7 ¹¹ / ₁₆ | | | |
| 8 | 1 ³ / ₈ | 1 ¹ / ₂ -12 | 1-14 | 1 ⁵ / ₈ | 1.999 | ⁵ / ₈ | 1 ¹ / ₈ | 1 ⁵ / ₁₆ | 4 | ¹ / ₄ | ⁷ / ₈ | 2 ⁵ / ₈ | 4 ¹⁵ / ₁₆ | 2 ¹³ / ₁₆ | 6 | 7 ⁵ / ₁₆ | | | |
| | 5 ¹ / ₂ | 5 ¹ / ₄ -12 | 4-12 | 5 ¹ / ₂ | 6.249 | 1 | 4 ⁵ / ₈ | 5 ³ / ₈ | 7 | ¹ / ₂ | 1 ¹ / ₂ | 3 ¹ / ₄ | 5 ⁹ / ₁₆ | 3 ⁷ / ₁₆ | 6 ⁵ / ₈ | 7 ¹⁵ / ₁₆ | | | |
| | 1 ³ / ₄ | 1 ¹ / ₂ -12 | 1 ¹ / ₄ -12 | 2 | 2.374 | ³ / ₄ | 1 ¹ / ₂ | 1 ¹¹ / ₁₆ | 4 | ³ / ₈ | 1 ¹ / ₈ | 2 ⁷ / ₈ | 5 ³ / ₁₆ | 3 ¹ / ₁₆ | 6 ¹ / ₄ | 7 ⁹ / ₁₆ | | | |
| | 2 | 1 ³ / ₄ -12 | 1 ¹ / ₂ -12 | 2 ¹ / ₄ | 2.624 | ⁷ / ₈ | 1 ¹¹ / ₁₆ | 1 ¹⁵ / ₁₆ | 4 | ³ / ₈ | 1 ¹ / ₄ | 3 | 5 ⁹ / ₁₆ | 3 ³ / ₁₆ | 6 ³ / ₈ | 7 ¹¹ / ₁₆ | | | |
| | 2 ¹ / ₂ | 2 ¹ / ₄ -12 | 1 ⁷ / ₈ -12 | 3 | 3.124 | 1 | 2 ¹ / ₁₆ | 2 ³ / ₈ | 4 | ¹ / ₂ | 1 ¹ / ₂ | 3 ¹ / ₄ | 5 ⁹ / ₁₆ | 3 ⁷ / ₁₆ | 6 ⁵ / ₈ | 7 ¹⁵ / ₁₆ | | | |
| | 3 | 2 ³ / ₄ -12 | 2 ¹ / ₄ -12 | 3 ¹ / ₂ | 3.749 | 1 | 2 ⁵ / ₈ | 2 ⁷ / ₈ | 5 ¹ / ₂ | ¹ / ₂ | 1 ¹ / ₂ | 3 ¹ / ₄ | 5 ⁹ / ₁₆ | 3 ⁷ / ₁₆ | 6 ⁵ / ₈ | 7 ¹⁵ / ₁₆ | | | |
| | 3 ¹ / ₂ | 3 ¹ / ₄ -12 | 2 ¹ / ₂ -12 | 3 ¹ / ₂ | 4.249 | 1 | 3 | 3 ³ / ₈ | 5 ¹ / ₂ | ¹ / ₂ | 1 ¹ / ₂ | 3 ¹ / ₄ | 5 ⁹ / ₁₆ | 3 ⁷ / ₁₆ | 6 ⁵ / ₈ | 7 ¹⁵ / ₁₆ | | | |
| | 4 | 3 ³ / ₄ -12 | 3-12 | 4 | 4.749 | 1 | 3 ³ / ₈ | 3 ⁷ / ₈ | 5 ¹ / ₂ | ¹ / ₂ | 1 ¹ / ₂ | 3 ¹ / ₄ | 5 ⁹ / ₁₆ | 3 ⁷ / ₁₆ | 6 ⁵ / ₈ | 7 ¹⁵ / ₁₆ | | | |
| | 4 ¹ / ₂ | 4 ¹ / ₄ -12 | 3 ¹ / ₄ -12 | 4 ¹ / ₂ | 5.249 | 1 | 3 ⁷ / ₈ | 4 ³ / ₈ | 7 | ¹ / ₂ | 1 ¹ / ₂ | 3 ¹ / ₄ | 5 ⁹ / ₁₆ | 3 ⁷ / ₁₆ | 6 ⁵ / ₈ | 7 ¹⁵ / ₁₆ | | | |
| 5 | 4 ³ / ₄ -12 | 3 ¹ / ₂ -12 | 5 | 5.749 | 1 | 4 ¹ / ₄ | 4 ⁷ / ₈ | 7 | ¹ / ₂ | 1 ¹ / ₂ | 3 ¹ / ₄ | 5 ⁹ / ₁₆ | 3 ⁷ / ₁₆ | 6 ⁵ / ₈ | 7 ¹⁵ / ₁₆ | | | | |
| 10 | 1 ³ / ₄ | 1 ¹ / ₂ -12 | 1 ¹ / ₄ -12 | 2 | 2.374 | ³ / ₄ | 1 ¹ / ₂ | 1 ¹¹ / ₁₆ | 4 | ³ / ₈ | 1 ¹ / ₈ | 3 | 5 ¹¹ / ₁₆ | 3 ¹ / ₈ | 7 ¹ / ₄ | 8 ¹⁵ / ₁₆ | | | |
| | 2 | 1 ³ / ₄ -12 | 1 ¹ / ₂ -12 | 2 ¹ / ₄ | 2.624 | ⁷ / ₈ | 1 ¹¹ / ₁₆ | 1 ¹⁵ / ₁₆ | 4 | ³ / ₈ | 1 ¹ / ₄ | 3 ¹ / ₈ | 5 ¹³ / ₁₆ | 3 ³ / ₄ | 7 ³ / ₈ | 9 ¹ / ₁₆ | | | |
| | 2 ¹ / ₂ | 2 ¹ / ₄ -12 | 1 ⁷ / ₈ -12 | 3 | 3.124 | 1 | 2 ¹ / ₁₆ | 2 ³ / ₈ | 4 | ¹ / ₂ | 1 ¹ / ₂ | 3 ³ / ₈ | 6 ¹ / ₁₆ | 3 ¹ / ₂ | 7 ⁵ / ₈ | 9 ⁵ / ₁₆ | | | |
| | 3 | 2 ³ / ₄ -12 | 2 ¹ / ₄ -12 | 3 ¹ / ₂ | 3.749 | 1 | 2 ⁵ / ₈ | 2 ⁷ / ₈ | 5 ¹ / ₂ | ¹ / ₂ | 1 ¹ / ₂ | 3 ³ / ₈ | 6 ¹ / ₁₆ | 3 ¹ / ₂ | 7 ⁵ / ₈ | 9 ⁵ / ₁₆ | | | |
| | 3 ¹ / ₂ | 3 ¹ / ₄ -12 | 2 ¹ / ₂ -12 | 3 ¹ / ₂ | 4.249 | 1 | 3 | 3 ³ / ₈ | 5 ¹ / ₂ | ¹ / ₂ | 1 ¹ / ₂ | 3 ³ / ₈ | 6 ¹ / ₁₆ | 3 ¹ / ₂ | 7 ⁵ / ₈ | 9 ⁵ / ₁₆ | | | |
| | 4 | 3 ³ / ₄ -12 | 3-12 | 4 | 4.749 | 1 | 3 ³ / ₈ | 3 ⁷ / ₈ | 5 ¹ / ₂ | ¹ / ₂ | 1 ¹ / ₂ | 3 ³ / ₈ | 6 ¹ / ₁₆ | 3 ¹ / ₂ | 7 ⁵ / ₈ | 9 ⁵ / ₁₆ | | | |
| | 4 ¹ / ₂ | 4 ¹ / ₄ -12 | 3 ¹ / ₄ -12 | 4 ¹ / ₂ | 5.249 | 1 | 3 ⁷ / ₈ | 4 ³ / ₈ | 7 | ¹ / ₂ | 1 ¹ / ₂ | 3 ³ / ₈ | 6 ¹ / ₁₆ | 3 ¹ / ₂ | 7 ⁵ / ₈ | 9 ⁵ / ₁₆ | | | |
| | 5 | 4 ³ / ₄ -12 | 3 ¹ / ₂ -12 | 5 | 5.749 | 1 | 4 ¹ / ₄ | 4 ⁷ / ₈ | 7 | ¹ / ₂ | 1 ¹ / ₂ | 3 ³ / ₈ | 6 ¹ / ₁₆ | 3 ¹ / ₂ | 7 ⁵ / ₈ | 9 ⁵ / ₁₆ | | | |
| 5 ¹ / ₂ | 5 ¹ / ₄ -12 | 4-12 | 5 ¹ / ₂ | 6.249 | 1 | 4 ⁵ / ₈ | 5 ³ / ₈ | 7 | ¹ / ₂ | 1 ¹ / ₂ | 3 ³ / ₈ | 6 ¹ / ₁₆ | 3 ¹ / ₂ | 7 ⁵ / ₈ | 9 ⁵ / ₁₆ | | | | |
| 12 | 2 | 1 ³ / ₄ -12 | 1 ¹ / ₂ -12 | 2 ¹ / ₄ | 2.624 | ⁷ / ₈ | 1 ¹¹ / ₁₆ | 1 ¹⁵ / ₁₆ | 4 | ³ / ₈ | 1 ¹ / ₄ | 3 ¹ / ₈ | 5 ¹³ / ₁₆ | 3 ¹ / ₄ | 7 ⁷ / ₈ | 9 ⁹ / ₁₆ | | | |
| | 2 ¹ / ₂ | 2 ¹ / ₄ -12 | 1 ⁷ / ₈ -12 | 3 | 3.124 | 1 | 2 ¹ / ₁₆ | 2 ³ / ₈ | 4 | ¹ / ₂ | 1 ¹ / ₂ | 3 ³ / ₈ | 6 ¹ / ₁₆ | 3 ¹ / ₂ | 8 ¹ / ₈ | 9 ¹³ / ₁₆ | | | |
| | 3 | 2 ³ / ₄ -12 | 2 ¹ / ₄ -12 | 3 ¹ / ₂ | 3.749 | 1 | 2 ⁵ / ₈ | 2 ⁷ / ₈ | 5 ¹ / ₂ | ¹ / ₂ | 1 ¹ / ₂ | 3 ³ / ₈ | 6 ¹ / ₁₆ | 3 ¹ / ₂ | 8 ¹ / ₈ | 9 ¹³ / ₁₆ | | | |
| | 3 ¹ / ₂ | 3 ¹ / ₄ -12 | 2 ¹ / ₂ -12 | 3 ¹ / ₂ | 4.249 | 1 | 3 | 3 ³ / ₈ | 5 ¹ / ₂ | ¹ / ₂ | 1 ¹ / ₂ | 3 ³ / ₈ | 6 ¹ / ₁₆ | 3 ¹ / ₂ | 8 ¹ / ₈ | 9 ¹³ / ₁₆ | | | |
| | 4 | 3 ³ / ₄ -12 | 3-12 | 4 | 4.749 | 1 | 3 ³ / ₈ | 3 ⁷ / ₈ | 5 ¹ / ₂ | ¹ / ₂ | 1 ¹ / ₂ | 3 ³ / ₈ | 6 ¹ / ₁₆ | 3 ¹ / ₂ | 8 ¹ / ₈ | 9 ¹³ / ₁₆ | | | |
| | 4 ¹ / ₂ | 4 ¹ / ₄ -12 | 3 ¹ / ₄ -12 | 4 ¹ / ₂ | 5.249 | 1 | 3 ⁷ / ₈ | 4 ³ / ₈ | 7 | ¹ / ₂ | 1 ¹ / ₂ | 3 ³ / ₈ | 6 ¹ / ₁₆ | 3 ¹ / ₂ | 8 ¹ / ₈ | 9 ¹³ / ₁₆ | | | |
| | 5 | 4 ³ / ₄ -12 | 3 ¹ / ₂ -12 | 5 | 5.749 | 1 | 4 ¹ / ₄ | 4 ⁷ / ₈ | 7 | ¹ / ₂ | 1 ¹ / ₂ | 3 ³ / ₈ | 6 ¹ / ₁₆ | 3 ¹ / ₂ | 8 ¹ / ₈ | 9 ¹³ / ₁₆ | | | |
| 5 ¹ / ₂ | 5 ¹ / ₄ -12 | 4-12 | 5 ¹ / ₂ | 6.249 | 1 | 4 ⁵ / ₈ | 5 ³ / ₈ | 7 | ¹ / ₂ | 1 ¹ / ₂ | 3 ³ / ₈ | 6 ¹ / ₁₆ | 3 ¹ / ₂ | 8 ¹ / ₈ | 9 ¹³ / ₁₆ | | | | |
| 14 | 2 ¹ / ₂ | 2 ¹ / ₄ -12 | 1 ⁷ / ₈ -12 | 3 | 3.124 | 1 | 2 ¹ / ₁₆ | 2 ³ / ₈ | 4 | ¹ / ₂ | 1 ¹ / ₂ | 3 ⁵ / ₈ | 6 ¹³ / ₁₆ | 3 ¹³ / ₁₆ | 9 ¹ / ₄ | 11 ¹ / ₈ | | | |
| | 3 | 2 ³ / ₄ -12 | 2 ¹ / ₄ -12 | 3 ¹ / ₂ | 3.749 | 1 | 2 ⁵ / ₈ | 2 ⁷ / ₈ | 5 ¹ / ₂ | ¹ / ₂ | 1 ¹ / ₂ | 3 ⁵ / ₈ | 6 ¹³ / ₁₆ | 3 ¹³ / ₁₆ | 9 ¹ / ₄ | 11 ¹ / ₈ | | | |
| | 3 ¹ / ₂ | 3 ¹ / ₄ -12 | 2 ¹ / ₂ -12 | 3 ¹ / ₂ | 4.249 | 1 | 3 | 3 ³ / ₈ | 5 ¹ / ₂ | ¹ / ₂ | 1 ¹ / ₂ | 3 ⁵ / ₈ | 6 ¹³ / ₁₆ | 3 ¹³ / ₁₆ | 9 ¹ / ₄ | 11 ¹ / ₈ | | | |
| | 4 | 3 ³ / ₄ -12 | 3-12 | 4 | 4.749 | 1 | 3 ³ / ₈ | 3 ⁷ / ₈ | 5 ¹ / ₂ | ¹ / ₂ | 1 ¹ / ₂ | 3 ⁵ / ₈ | 6 ¹³ / ₁₆ | 3 ¹³ / ₁₆ | 9 ¹ / ₄ | 11 ¹ / ₈ | | | |
| | 4 ¹ / ₂ | 4 ¹ / ₄ -12 | 3 ¹ / ₄ -12 | 4 ¹ / ₂ | 5.249 | 1 | 3 ⁷ / ₈ | 4 ³ / ₈ | 7 | ¹ / ₂ | 1 ¹ / ₂ | 3 ⁵ / ₈ | 6 ¹³ / ₁₆ | 3 ¹³ / ₁₆ | 9 ¹ / ₄ | 11 ¹ / ₈ | | | |
| | 5 | 4 ³ / ₄ -12 | 3 ¹ / ₂ -12 | 5 | 5.749 | 1 | 4 ¹ / ₄ | 4 ⁷ / ₈ | 7 | ¹ / ₂ | 1 ¹ / ₂ | 3 ⁵ / ₈ | 6 ¹³ / ₁₆ | 3 ¹³ / ₁₆ | 9 ¹ / ₄ | 11 ¹ / ₈ | | | |
| 5 ¹ / ₂ | 5 ¹ / ₄ -12 | 4-12 | 5 ¹ / ₂ | 6.249 | 1 | 4 ⁵ / ₈ | 5 ³ / ₈ | 7 | ¹ / ₂ | 1 ¹ / ₂ | 3 ⁵ / ₈ | 6 ¹³ / ₁₆ | 3 ¹³ / ₁₆ | 9 ¹ / ₄ | 11 ¹ / ₈ | | | | |

Miller AV Series Heavy-Duty Air Cylinders

Cap Fixed Clevis Mount
Tie Rods Extended Mountings
7" to 14" Bore Sizes

Cap Fixed Clevis Mount Model 84 7" - 14" Bore

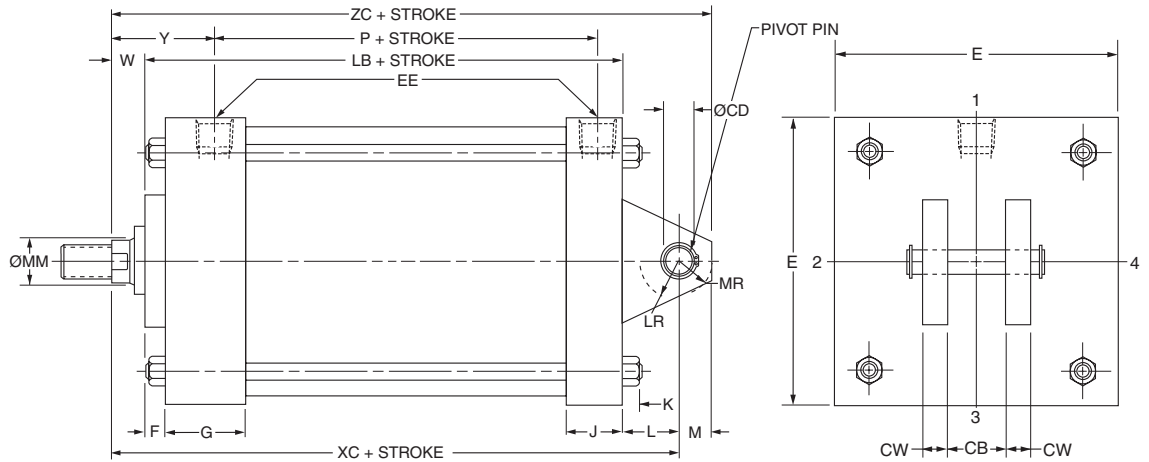
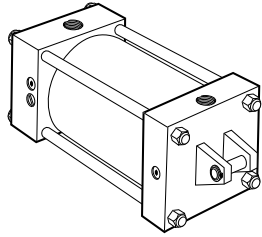

Tie Rods Extended Mountings Model 53 7" - 14" Bore

Model 53 Head Tie Rods Extended, Illustrated. Model 52 Cap Tie Rods Extended; and Model 51, Both Ends Tie Rods Extended are also available. All Tie Rod Models can be dimensioned from Model 53 drawing below.

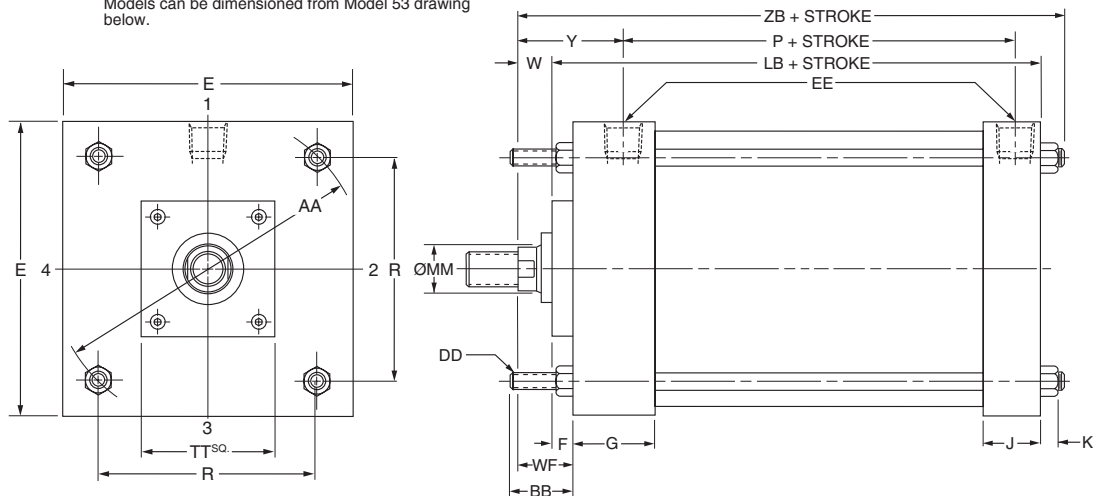
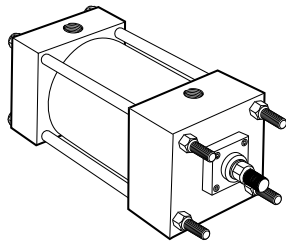

Models 51 and 53 not offered in 8" bore, rod diameters 4 1/2", 5" and 5 1/2".

Rod End Dimensions — see table 2

Thread Style 2 Small Male

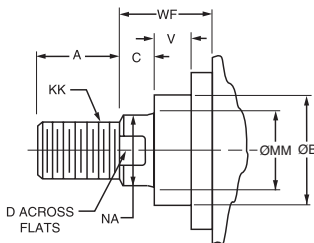

A high strength rod end stud is supplied on thread style 2 through 2" diameter rods and on thread style 5 through 1 3/8" diameter rods. Larger sizes or special rod ends are cut threads. Style 2 rod ends are recommended where the workpiece is secured against the rod shoulder. When the workpiece is not shouldered, style 2 rod ends

Thread Style 4 Short Female

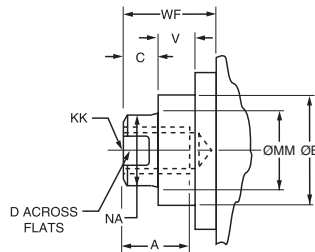

are recommended through 2" piston rod diameters and style 5 rod ends are recommended on larger diameters. Use style 4 for applications where female rod end threads are required. If rod end is not specified, style 2 will be supplied.

Thread Style 5 Intermediate Male

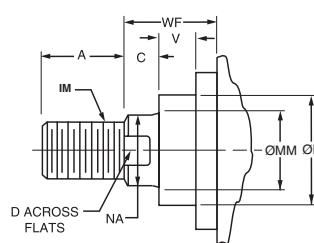

"Special" Thread Style X

Special thread, extension, rod eye, blank, etc., are also available.

To order, specify "Style X" and give desired dimensions for KK , A and WF . If otherwise special, furnish dimensioned sketch.

Miller AV Series Heavy-Duty Air Cylinders

Cap Fixed Clevis Mount
Tie Rods Extended Mountings
7" to 14" Bore Sizes

Table 1—Envelope and Mounting Dimensions

| Bore | AA | BB | CB | CDØ* +.000 -.001 | CW | DD | E | EE NPTF | F | G | J | K | L | LR | M | MR | R | Add Stroke | |
|------|------|---------------------------------|-------------------------------|------------------------|-------------------------------|---------------------------------|--------------------------------|-------------------------------|-----------------------------|-------------------------------|-------------------------------|-------------------------------|-------------------------------|-------------------------------|-------------------------------|--------------------------------|-------|-------------------------------|-------------------------------|
| | | | | | | | | | | | | | | | | | | LB | P |
| 7 | 8.1 | 2 ⁵ / ₁₆ | 1 ¹ / ₂ | 1.000 | ³ / ₄ | ⁵ / ₈ -18 | 7 ¹ / ₂ | ³ / ₄ | ³ / ₄ | 2 | 1 ¹ / ₂ | ⁹ / ₁₆ | 1 ¹ / ₂ | 1 ¹ / ₄ | 1 | 1 ³ / ₁₆ | 5.73 | 5 ⁷ / ₈ | 3 ¹ / ₄ |
| 8 | 9.1 | 2 ⁵ / ₁₆ | 1 ¹ / ₂ | 1.000 | ³ / ₄ | ⁵ / ₈ -18 | 8 ¹ / ₂ | ³ / ₄ | ³ / ₄ | 2 | 1 ¹ / ₂ | ⁹ / ₁₆ | 1 ¹ / ₂ | 1 ¹ / ₄ | 1 | 1 ³ / ₁₆ | 6.44 | 5 ⁷ / ₈ | 3 ¹ / ₄ |
| 10 | 11.2 | 2 ¹¹ / ₁₆ | 2 | 1.375 | 1 | ³ / ₄ -16 | 10 ⁹ / ₈ | 1 | ³ / ₄ | 2 ¹ / ₄ | 2 | ¹¹ / ₁₆ | 2 ¹ / ₈ | 1 ⁷ / ₈ | 1 ³ / ₈ | 1 ⁵ / ₈ | 7.92 | 7 ¹ / ₈ | 4 ¹ / ₈ |
| 12 | 13.3 | 2 ¹¹ / ₁₆ | 2 ¹ / ₂ | 1.750 | 1 ¹ / ₄ | ³ / ₄ -16 | 12 ³ / ₄ | 1 | ³ / ₄ | 2 ¹ / ₄ | 2 | ¹¹ / ₁₆ | 2 ¹ / ₄ | 2 ¹ / ₈ | 1 ³ / ₄ | 2 ¹ / ₈ | 9.40 | 7 ⁵ / ₈ | 4 ⁵ / ₈ |
| 14 | 15.4 | 3 ³ / ₁₆ | 2 ¹ / ₂ | 2.000 | 1 ¹ / ₄ | ⁷ / ₈ -14 | 14 ³ / ₄ | 1 ¹ / ₄ | ³ / ₄ | 2 ³ / ₄ | 2 ¹ / ₄ | ³ / ₄ | 2 ¹ / ₂ | 2 ³ / ₈ | 2 | 2 ³ / ₈ | 10.90 | 8 ⁷ / ₈ | 5 ¹ / ₂ |

* CD is pin diameter.

Table 2—Rod End Dimensions and Envelope Dimensions Affected By Rod Size

| Bore | MM Rod Ø | Thread | | Rod End Dimensions and Envelope Dimensions Affected By Rod Size | | | | | | | | | | | | | Add Stroke | |
|-------------------------------|-----------------------------------|-----------------------------------|-----------------------------------|---|-----------------------|-------------------------------|---------------------------------|---------------------------------|-------------------------------|-------------------------------|-------------------------------|--------------------------------|--------------------------------|---------------------------------|---------------------------------|--------------------------------|------------|--|
| | | Style 5 IM | Style 2 & 4 KK | A | B Ø +.000 -.002 | C | D | NA | TT | V | W | WF | XC | Y | ZB | ZC | | |
| | | | | | | | | | | | | | | | | | | |
| 7 | 1 ³ / ₈ | 1 ¹ / ₄ -12 | 1-14 | 1 ⁵ / ₈ | 1.999 | ⁵ / ₈ | 1 ¹ / ₈ | 1 ⁵ / ₁₆ | 4 | ¹ / ₄ | ⁷ / ₈ | 1 ⁵ / ₈ | 8 ¹ / ₄ | 2 ¹³ / ₁₆ | 7 ⁵ / ₁₆ | 9 ¹ / ₄ | | |
| | 1 ³ / ₄ | 1 ¹ / ₂ -12 | 1 ¹ / ₄ -12 | 2 | 2.374 | ³ / ₄ | 1 ¹ / ₂ | 1 ¹¹ / ₁₆ | 4 | ³ / ₈ | 1 ¹ / ₈ | 1 ⁷ / ₈ | 8 ¹ / ₂ | 3 ¹ / ₁₆ | 7 ⁹ / ₁₆ | 9 ¹ / ₂ | | |
| | 2 | 1 ³ / ₄ -12 | 1 ¹ / ₂ -12 | 2 ¹ / ₄ | 2.624 | ⁷ / ₈ | 1 ¹¹ / ₁₆ | 1 ¹⁵ / ₁₆ | 4 | ³ / ₈ | 1 ¹ / ₄ | 2 | 8 ⁵ / ₈ | 3 ³ / ₁₆ | 7 ¹¹ / ₁₆ | 9 ⁵ / ₈ | | |
| 8 | 1 ³ / ₈ | 1 ¹ / ₄ -12 | 1-14 | 1 ⁵ / ₈ | 1.999 | ⁵ / ₈ | 1 ¹ / ₈ | 1 ⁵ / ₁₆ | 4 | ¹ / ₄ | ⁷ / ₈ | 1 ⁵ / ₈ | 8 ¹ / ₄ | 2 ¹³ / ₁₆ | 7 ⁵ / ₁₆ | 9 ¹ / ₄ | | |
| | 5 ¹ / ₂ | 5 ¹ / ₄ -12 | 4-12 | 5 ¹ / ₂ | 6.249 | 1 | 4 ⁵ / ₈ | 5 ³ / ₈ | 7 | ¹ / ₂ | 1 ¹ / ₂ | 2 ¹ / ₄ | 8 ⁷ / ₈ | 3 ⁷ / ₁₆ | 7 ¹⁵ / ₁₆ | 9 ⁷ / ₈ | | |
| | 1 ³ / ₄ | 1 ¹ / ₂ -12 | 1 ¹ / ₄ -12 | 2 | 2.374 | ³ / ₄ | 1 ¹ / ₂ | 1 ¹¹ / ₁₆ | 4 | ³ / ₈ | 1 ¹ / ₈ | 1 ⁷ / ₈ | 8 ¹ / ₂ | 3 ¹ / ₁₆ | 7 ⁹ / ₁₆ | 9 ¹ / ₂ | | |
| | 2 | 1 ³ / ₄ -12 | 1 ¹ / ₂ -12 | 2 ¹ / ₄ | 2.624 | ⁷ / ₈ | 1 ¹¹ / ₁₆ | 1 ¹⁵ / ₁₆ | 4 | ³ / ₈ | 1 ¹ / ₄ | 2 | 8 ⁵ / ₈ | 3 ³ / ₁₆ | 7 ¹¹ / ₁₆ | 9 ⁵ / ₈ | | |
| | 2 ¹ / ₂ | 2 ¹ / ₄ -12 | 1 ⁷ / ₈ -12 | 3 | 3.124 | 1 | 2 ¹ / ₁₆ | 2 ³ / ₈ | 4 | ¹ / ₂ | 1 ¹ / ₂ | 2 ¹ / ₄ | 8 ⁷ / ₈ | 3 ⁷ / ₁₆ | 7 ¹⁵ / ₁₆ | 9 ⁷ / ₈ | | |
| | 3 | 2 ³ / ₄ -12 | 2 ¹ / ₄ -12 | 3 ¹ / ₂ | 3.749 | 1 | 2 ⁵ / ₈ | 2 ⁷ / ₈ | 5 ¹ / ₂ | ¹ / ₂ | 1 ¹ / ₂ | 2 ¹ / ₄ | 8 ⁷ / ₈ | 3 ⁷ / ₁₆ | 7 ¹⁵ / ₁₆ | 9 ⁷ / ₈ | | |
| | 3 ¹ / ₂ | 3 ¹ / ₄ -12 | 2 ¹ / ₂ -12 | 3 ¹ / ₂ | 4.249 | 1 | 3 | 3 ³ / ₈ | 5 ¹ / ₂ | ¹ / ₂ | 1 ¹ / ₂ | 2 ¹ / ₄ | 8 ⁷ / ₈ | 3 ⁷ / ₁₆ | 7 ¹⁵ / ₁₆ | 9 ⁷ / ₈ | | |
| | 4 | 3 ³ / ₄ -12 | 3-12 | 4 | 4.749 | 1 | 3 ³ / ₈ | 3 ⁷ / ₈ | 5 ¹ / ₂ | ¹ / ₂ | 1 ¹ / ₂ | 2 ¹ / ₄ | 8 ⁷ / ₈ | 3 ⁷ / ₁₆ | 7 ¹⁵ / ₁₆ | 9 ⁷ / ₈ | | |
| 4 ¹ / ₂ | 4 ¹ / ₄ -12 | 3 ¹ / ₄ -12 | 4 ¹ / ₂ | 5.249 | 1 | 3 ⁷ / ₈ | 4 ³ / ₈ | 7 | ¹ / ₂ | 1 ¹ / ₂ | 2 ¹ / ₄ | 8 ⁷ / ₈ | 3 ⁷ / ₁₆ | 7 ¹⁵ / ₁₆ | 9 ⁷ / ₈ | | | |
| 5 | 4 ³ / ₄ -12 | 3 ¹ / ₂ -12 | 5 | 5.749 | 1 | 4 ¹ / ₄ | 4 ⁷ / ₈ | 7 | ¹ / ₂ | 1 ¹ / ₂ | 2 ¹ / ₄ | 8 ⁷ / ₈ | 3 ⁷ / ₁₆ | 7 ¹⁵ / ₁₆ | 9 ⁷ / ₈ | | | |
| 10 | 1 ³ / ₄ | 1 ¹ / ₂ -12 | 1 ¹ / ₄ -12 | 2 | 2.374 | ³ / ₄ | 1 ¹ / ₂ | 1 ¹¹ / ₁₆ | 4 | ³ / ₈ | 1 ¹ / ₈ | 1 ⁷ / ₈ | 10 ³ / ₈ | 3 ¹ / ₈ | 8 ¹⁵ / ₁₆ | 11 ³ / ₄ | | |
| | 2 | 1 ³ / ₄ -12 | 1 ¹ / ₂ -12 | 2 ¹ / ₄ | 2.624 | ⁷ / ₈ | 1 ¹¹ / ₁₆ | 1 ¹⁵ / ₁₆ | 4 | ³ / ₈ | 1 ¹ / ₄ | 2 | 10 ¹ / ₂ | 3 ¹ / ₄ | 9 ¹ / ₁₆ | 11 ⁷ / ₈ | | |
| | 2 ¹ / ₂ | 2 ¹ / ₄ -12 | 1 ⁷ / ₈ -12 | 3 | 3.124 | 1 | 2 ¹ / ₁₆ | 2 ³ / ₈ | 4 | ¹ / ₂ | 1 ¹ / ₂ | 2 ¹ / ₄ | 10 ³ / ₄ | 3 ¹ / ₂ | 9 ⁵ / ₁₆ | 12 ¹ / ₈ | | |
| | 3 | 2 ³ / ₄ -12 | 2 ¹ / ₄ -12 | 3 ¹ / ₂ | 3.749 | 1 | 2 ⁵ / ₈ | 2 ⁷ / ₈ | 5 ¹ / ₂ | ¹ / ₂ | 1 ¹ / ₂ | 2 ¹ / ₄ | 10 ³ / ₄ | 3 ¹ / ₂ | 9 ⁵ / ₁₆ | 12 ¹ / ₈ | | |
| | 3 ¹ / ₂ | 3 ¹ / ₄ -12 | 2 ¹ / ₂ -12 | 3 ¹ / ₂ | 4.249 | 1 | 3 | 3 ³ / ₈ | 5 ¹ / ₂ | ¹ / ₂ | 1 ¹ / ₂ | 2 ¹ / ₄ | 10 ³ / ₄ | 3 ¹ / ₂ | 9 ⁵ / ₁₆ | 12 ¹ / ₈ | | |
| | 4 | 3 ³ / ₄ -12 | 3-12 | 4 | 4.749 | 1 | 3 ³ / ₈ | 3 ⁷ / ₈ | 5 ¹ / ₂ | ¹ / ₂ | 1 ¹ / ₂ | 2 ¹ / ₄ | 10 ³ / ₄ | 3 ¹ / ₂ | 9 ⁵ / ₁₆ | 12 ¹ / ₈ | | |
| | 4 ¹ / ₂ | 4 ¹ / ₄ -12 | 3 ¹ / ₄ -12 | 4 ¹ / ₂ | 5.249 | 1 | 3 ⁷ / ₈ | 4 ³ / ₈ | 7 | ¹ / ₂ | 1 ¹ / ₂ | 2 ¹ / ₄ | 10 ³ / ₄ | 3 ¹ / ₂ | 9 ⁵ / ₁₆ | 12 ¹ / ₈ | | |
| | 5 | 4 ³ / ₄ -12 | 3 ¹ / ₂ -12 | 5 | 5.749 | 1 | 4 ¹ / ₄ | 4 ⁷ / ₈ | 7 | ¹ / ₂ | 1 ¹ / ₂ | 2 ¹ / ₄ | 10 ³ / ₄ | 3 ¹ / ₂ | 9 ⁵ / ₁₆ | 12 ¹ / ₈ | | |
| 5 ¹ / ₂ | 5 ¹ / ₄ -12 | 4-12 | 5 ¹ / ₂ | 6.249 | 1 | 4 ⁵ / ₈ | 5 ³ / ₈ | 7 | ¹ / ₂ | 1 ¹ / ₂ | 2 ¹ / ₄ | 10 ³ / ₄ | 3 ¹ / ₂ | 9 ⁵ / ₁₆ | 12 ¹ / ₈ | | | |
| 12 | 2 | 1 ³ / ₄ -12 | 1 ¹ / ₂ -12 | 2 ¹ / ₄ | 2.624 | ⁷ / ₈ | 1 ¹¹ / ₁₆ | 1 ¹⁵ / ₁₆ | 4 | ³ / ₈ | 1 ¹ / ₄ | 2 | 11 ¹ / ₈ | 3 ¹ / ₄ | 9 ⁹ / ₁₆ | 12 ⁷ / ₈ | | |
| | 2 ¹ / ₂ | 2 ¹ / ₄ -12 | 1 ⁷ / ₈ -12 | 3 | 3.124 | 1 | 2 ¹ / ₁₆ | 2 ³ / ₈ | 4 | ¹ / ₂ | 1 ¹ / ₂ | 2 ¹ / ₄ | 11 ³ / ₈ | 3 ¹ / ₂ | 9 ¹³ / ₁₆ | 13 ¹ / ₈ | | |
| | 3 | 2 ³ / ₄ -12 | 2 ¹ / ₄ -12 | 3 ¹ / ₂ | 3.749 | 1 | 2 ⁵ / ₈ | 2 ⁷ / ₈ | 5 ¹ / ₂ | ¹ / ₂ | 1 ¹ / ₂ | 2 ¹ / ₄ | 11 ³ / ₈ | 3 ¹ / ₂ | 9 ¹³ / ₁₆ | 13 ¹ / ₈ | | |
| | 3 ¹ / ₂ | 3 ¹ / ₄ -12 | 2 ¹ / ₂ -12 | 3 ¹ / ₂ | 4.249 | 1 | 3 | 3 ³ / ₈ | 5 ¹ / ₂ | ¹ / ₂ | 1 ¹ / ₂ | 2 ¹ / ₄ | 11 ³ / ₈ | 3 ¹ / ₂ | 9 ¹³ / ₁₆ | 13 ¹ / ₈ | | |
| | 4 | 3 ³ / ₄ -12 | 3-12 | 4 | 4.749 | 1 | 3 ³ / ₈ | 3 ⁷ / ₈ | 5 ¹ / ₂ | ¹ / ₂ | 1 ¹ / ₂ | 2 ¹ / ₄ | 11 ³ / ₈ | 3 ¹ / ₂ | 9 ¹³ / ₁₆ | 13 ¹ / ₈ | | |
| | 4 ¹ / ₂ | 4 ¹ / ₄ -12 | 3 ¹ / ₄ -12 | 4 ¹ / ₂ | 5.249 | 1 | 3 ⁷ / ₈ | 4 ³ / ₈ | 7 | ¹ / ₂ | 1 ¹ / ₂ | 2 ¹ / ₄ | 11 ³ / ₈ | 3 ¹ / ₂ | 9 ¹³ / ₁₆ | 13 ¹ / ₈ | | |
| | 5 | 4 ³ / ₄ -12 | 3 ¹ / ₂ -12 | 5 | 5.749 | 1 | 4 ¹ / ₄ | 4 ⁷ / ₈ | 7 | ¹ / ₂ | 1 ¹ / ₂ | 2 ¹ / ₄ | 11 ³ / ₈ | 3 ¹ / ₂ | 9 ¹³ / ₁₆ | 13 ¹ / ₈ | | |
| 5 ¹ / ₂ | 5 ¹ / ₄ -12 | 4-12 | 5 ¹ / ₂ | 6.249 | 1 | 4 ⁵ / ₈ | 5 ³ / ₈ | 7 | ¹ / ₂ | 1 ¹ / ₂ | 2 ¹ / ₄ | 11 ³ / ₈ | 3 ¹ / ₂ | 9 ¹³ / ₁₆ | 13 ¹ / ₈ | | | |
| 14 | 2 ¹ / ₂ | 2 ¹ / ₄ -12 | 1 ⁷ / ₈ -12 | 3 | 3.124 | 1 | 2 ¹ / ₁₆ | 2 ³ / ₈ | 4 | ¹ / ₂ | 1 ¹ / ₂ | 2 ¹ / ₄ | 12 ⁷ / ₈ | 3 ¹³ / ₁₆ | 11 ¹ / ₈ | 14 ⁷ / ₈ | | |
| | 3 | 2 ³ / ₄ -12 | 2 ¹ / ₄ -12 | 3 ¹ / ₂ | 3.749 | 1 | 2 ⁵ / ₈ | 2 ⁷ / ₈ | 5 ¹ / ₂ | ¹ / ₂ | 1 ¹ / ₂ | 2 ¹ / ₄ | 12 ⁷ / ₈ | 3 ¹³ / ₁₆ | 11 ¹ / ₈ | 14 ⁷ / ₈ | | |
| | 3 ¹ / ₂ | 3 ¹ / ₄ -12 | 2 ¹ / ₂ -12 | 3 ¹ / ₂ | 4.249 | 1 | 3 | 3 ³ / ₈ | 5 ¹ / ₂ | ¹ / ₂ | 1 ¹ / ₂ | 2 ¹ / ₄ | 12 ⁷ / ₈ | 3 ¹³ / ₁₆ | 11 ¹ / ₈ | 14 ⁷ / ₈ | | |
| | 4 | 3 ³ / ₄ -12 | 3-12 | 4 | 4.749 | 1 | 3 ³ / ₈ | 3 ⁷ / ₈ | 5 ¹ / ₂ | ¹ / ₂ | 1 ¹ / ₂ | 2 ¹ / ₄ | 12 ⁷ / ₈ | 3 ¹³ / ₁₆ | 11 ¹ / ₈ | 14 ⁷ / ₈ | | |
| | 4 ¹ / ₂ | 4 ¹ / ₄ -12 | 3 ¹ / ₄ -12 | 4 ¹ / ₂ | 5.249 | 1 | 3 ⁷ / ₈ | 4 ³ / ₈ | 7 | ¹ / ₂ | 1 ¹ / ₂ | 2 ¹ / ₄ | 12 ⁷ / ₈ | 3 ¹³ / ₁₆ | 11 ¹ / ₈ | 14 ⁷ / ₈ | | |
| | 5 | 4 ³ / ₄ -12 | 3 ¹ / ₂ -12 | 5 | 5.749 | 1 | 4 ¹ / ₄ | | | | | | | | | | | |

Miller AV Series Heavy-Duty Air Cylinders

Double Rod End Cylinders
7" to 14" Bore Sizes

How to Use Double Rod Cylinder Dimension Drawings

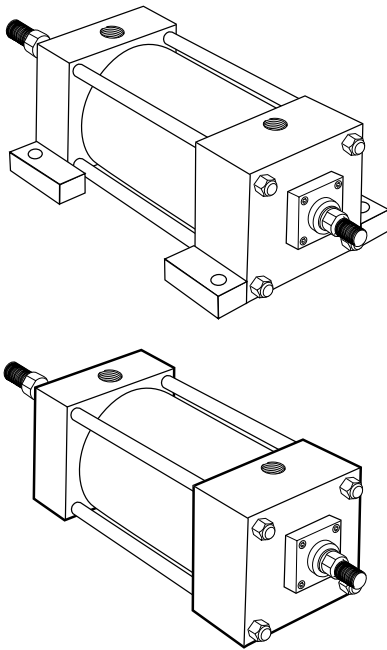

To determine dimensions for a double rod cylinder, first refer to the desired single rod mounting style cylinder shown on preceding pages of this catalog. After selecting necessary dimensions from that drawing, return to this page and supplement the single rod dimensions with those shown on the drawing and dimension table below. Note that double rod cylinders have a head (Dim. G) at both ends and that dimension LD replaces LB. The double rod dimensions differ from, or are in addition to those for single rod cylinders shown on preceding pages and provide the information needed to completely dimension a double rod cylinder. On a double rod cylinder where the two rod ends are different, be sure to clearly state which rod end is to be assembled at which end.

Port position 1 is standard. If other than standard, specify pos. 2, 3 or 4 when viewed from one end only.

7"- 14" Bore

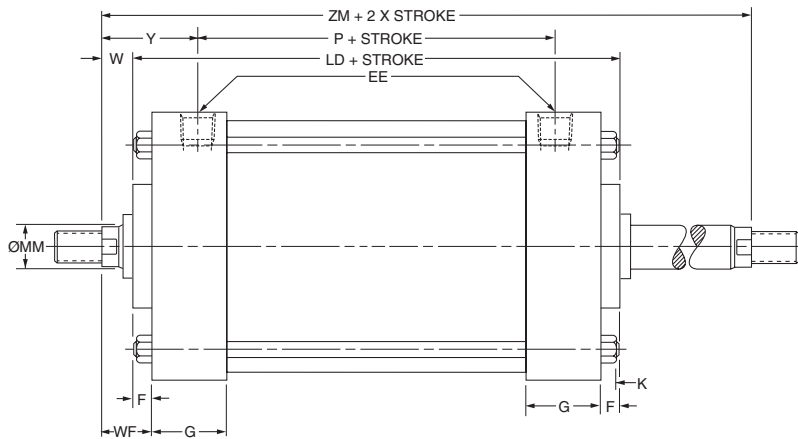

Rod End Dimensions — see table 2

Thread Style 2
Small Male

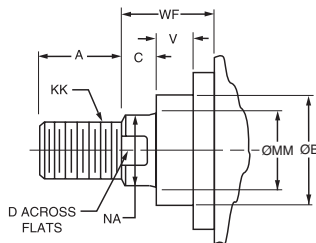

Thread Style 4
Short Female

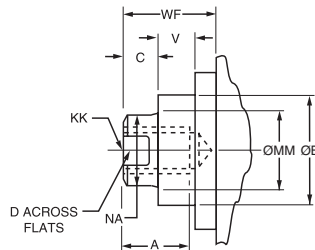

Thread Style 5
Intermediate Male

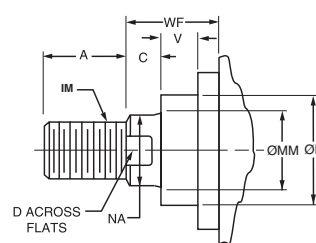

“Special” Thread Style X

Special thread, extension, rod eye, blank, etc., are also available.

To order, specify “Style X” and give desired dimensions for KK, A and WF. If otherwise special, furnish dimensional sketch.

A high strength rod end stud is supplied on thread style 2 through 2" diameter rods and on thread style 5 through 1 3/8" diameter rods. Larger sizes or special rod ends are cut threads. Style 2 rod ends are recommended where the workpiece is secured against the rod shoulder. When the workpiece is not shouldered, style 2 rod ends

are recommended through 2" piston rod diameters and style 5 rod ends are recommended on larger diameters. Use style 4 for applications where female rod end threads are required. If rod end is not specified, style 2 will be supplied.

Miller AV Series Heavy-Duty Air Cylinders

Double Rod End Cylinders
7" to 14" Bore Sizes

Table 1—Envelope and Mounting Dimensions

| Bore | E | EE NPTF | F | G | K | Add Stroke | | |
|------|--------------------------------|-------------------------------|-----------------------------|-------------------------------|-------------------------------|--------------------------------|-------------------------------|-------------------------------|
| | | | | | | LD | P | SS |
| 7 | 7 ¹ / ₂ | ³ / ₄ | ³ / ₄ | 2 | ⁹ / ₁₆ | 7 ¹ / ₈ | 3 ¹ / ₄ | 4 ¹ / ₄ |
| 8 | 8 ¹ / ₂ | ³ / ₄ | ³ / ₄ | 2 | ⁹ / ₁₆ | 7 ¹ / ₈ | 3 ¹ / ₄ | 4 ¹ / ₄ |
| 10 | 10 ⁵ / ₈ | 1 | ³ / ₄ | 2 ¹ / ₄ | ¹¹ / ₁₆ | 8 ¹ / ₈ | 4 ¹ / ₈ | 4 ⁷ / ₈ |
| 12 | 12 ³ / ₄ | 1 | ³ / ₄ | 2 ¹ / ₄ | ¹¹ / ₁₆ | 8 ⁵ / ₈ | 4 ⁵ / ₈ | 5 ³ / ₈ |
| 14 | 14 ³ / ₄ | 1 ¹ / ₄ | ³ / ₄ | 2 ³ / ₄ | ³ / ₄ | 10 ¹ / ₈ | 5 ¹ / ₂ | 6 ³ / ₈ |

Table 2—Rod End Dimensions and Envelope Dimensions Affected By Rod Size

| Bore | MM Rod Ø | Thread | | Rod End Dimensions and Envelope Dimensions Affected By Rod Size | | | | | | | | | | Add Stroke ZM |
|------|-------------------------------|-----------------------------------|-----------------------------------|---|-----------------------|-----------------------------|---------------------------------|---------------------------------|-----------------------------|-------------------------------|-------------------------------|---------------------------------|--------------------------------|------------------|
| | | Style 5 IM | Style 2 & 4 KK | A | B Ø +.000 -.002 | C | D | NA | V | W | WF | Y | | |
| | | | | | | | | | | | | | | |
| 7 | 1 ³ / ₈ | 1 ¹ / ₄ -12 | 1-14 | 1 ⁵ / ₈ | 1.999 | ⁵ / ₈ | 1 ¹ / ₈ | 1 ⁵ / ₁₆ | ¹ / ₄ | ⁷ / ₈ | 1 ⁵ / ₈ | 2 ¹³ / ₁₆ | 8 ⁷ / ₈ | |
| | 1 ³ / ₄ | 1 ¹ / ₂ -12 | 1 ¹ / ₄ -12 | 2 | 2.374 | ³ / ₄ | 1 ¹ / ₂ | 1 ¹¹ / ₁₆ | ³ / ₈ | 1 ¹ / ₈ | 1 ⁷ / ₈ | 3 ¹ / ₁₆ | 9 ³ / ₈ | |
| | 2 | 1 ³ / ₄ -12 | 1 ¹ / ₂ -12 | 2 ¹ / ₄ | 2.624 | ⁷ / ₈ | 1 ¹¹ / ₁₆ | 1 ¹⁵ / ₁₆ | ³ / ₈ | 1 ¹ / ₄ | 2 | 3 ³ / ₁₆ | 9 ⁵ / ₈ | |
| 8 | 1 ³ / ₈ | 1 ¹ / ₄ -12 | 1-14 | 1 ⁵ / ₈ | 1.999 | ⁵ / ₈ | 1 ¹ / ₈ | 1 ⁵ / ₁₆ | ¹ / ₄ | ⁷ / ₈ | 1 ⁵ / ₈ | 2 ¹³ / ₁₆ | 8 ⁷ / ₈ | |
| | 5 ¹ / ₂ | 5 ¹ / ₄ -12 | 4-12 | 5 ¹ / ₂ | 6.249 | 1 | 4 ⁵ / ₈ | 5 ³ / ₈ | ¹ / ₂ | 1 ¹ / ₂ | 2 ¹ / ₄ | 3 ⁷ / ₁₆ | 10 ¹ / ₈ | |
| | 1 ³ / ₄ | 1 ¹ / ₂ -12 | 1 ¹ / ₄ -12 | 2 | 2.374 | ³ / ₄ | 1 ¹ / ₂ | 1 ¹¹ / ₁₆ | ³ / ₈ | 1 ¹ / ₈ | 1 ⁷ / ₈ | 3 ¹ / ₁₆ | 9 ³ / ₈ | |
| | 2 | 1 ³ / ₄ -12 | 1 ¹ / ₂ -12 | 2 ¹ / ₄ | 2.624 | ⁷ / ₈ | 1 ¹¹ / ₁₆ | 1 ¹⁵ / ₁₆ | ³ / ₈ | 1 ¹ / ₄ | 2 | 3 ³ / ₁₆ | 9 ⁵ / ₈ | |
| | 2 ¹ / ₂ | 2 ¹ / ₄ -12 | 1 ⁷ / ₈ -12 | 3 | 3.124 | 1 | 2 ¹ / ₁₆ | 2 ³ / ₈ | ¹ / ₂ | 1 ¹ / ₂ | 2 ¹ / ₄ | 3 ⁷ / ₁₆ | 10 ¹ / ₈ | |
| | 3 | 2 ³ / ₄ -12 | 2 ¹ / ₄ -12 | 3 ¹ / ₂ | 3.749 | 1 | 2 ⁵ / ₈ | 2 ⁷ / ₈ | ¹ / ₂ | 1 ¹ / ₂ | 2 ¹ / ₄ | 3 ⁷ / ₁₆ | 10 ¹ / ₈ | |
| | 3 ¹ / ₂ | 3 ¹ / ₄ -12 | 2 ¹ / ₂ -12 | 3 ¹ / ₂ | 4.249 | 1 | 3 | 3 ³ / ₈ | ¹ / ₂ | 1 ¹ / ₂ | 2 ¹ / ₄ | 3 ⁷ / ₁₆ | 10 ¹ / ₈ | |
| | 4 | 3 ³ / ₄ -12 | 3-12 | 4 | 4.749 | 1 | 3 ³ / ₈ | 3 ⁷ / ₈ | ¹ / ₂ | 1 ¹ / ₂ | 2 ¹ / ₄ | 3 ⁷ / ₁₆ | 10 ¹ / ₈ | |
| 10 | 4 ¹ / ₂ | 4 ¹ / ₄ -12 | 3 ¹ / ₄ -12 | 4 ¹ / ₂ | 5.249 | 1 | 3 ⁷ / ₈ | 4 ³ / ₈ | ¹ / ₂ | 1 ¹ / ₂ | 2 ¹ / ₄ | 3 ⁷ / ₁₆ | 10 ¹ / ₈ | |
| | 5 | 4 ³ / ₄ -12 | 3 ¹ / ₂ -12 | 5 | 5.749 | 1 | 4 ¹ / ₄ | 4 ⁷ / ₈ | ¹ / ₂ | 1 ¹ / ₂ | 2 ¹ / ₄ | 3 ⁷ / ₁₆ | 10 ¹ / ₈ | |
| | 1 ³ / ₄ | 1 ¹ / ₂ -12 | 1 ¹ / ₄ -12 | 2 | 2.374 | ³ / ₄ | 1 ¹ / ₂ | 1 ¹¹ / ₁₆ | ³ / ₈ | 1 ¹ / ₈ | 1 ⁷ / ₈ | 3 ¹ / ₈ | 10 ³ / ₈ | |
| | 2 | 1 ³ / ₄ -12 | 1 ¹ / ₂ -12 | 2 ¹ / ₄ | 2.624 | ⁷ / ₈ | 1 ¹¹ / ₁₆ | 1 ¹⁵ / ₁₆ | ³ / ₈ | 1 ¹ / ₄ | 2 | 3 ¹ / ₄ | 10 ⁵ / ₈ | |
| | 2 ¹ / ₂ | 2 ¹ / ₄ -12 | 1 ⁷ / ₈ -12 | 3 | 3.124 | 1 | 2 ¹ / ₁₆ | 2 ³ / ₈ | ¹ / ₂ | 1 ¹ / ₂ | 2 ¹ / ₄ | 3 ¹ / ₂ | 11 ¹ / ₈ | |
| | 3 | 2 ³ / ₄ -12 | 2 ¹ / ₄ -12 | 3 ¹ / ₂ | 3.749 | 1 | 2 ⁵ / ₈ | 2 ⁷ / ₈ | ¹ / ₂ | 1 ¹ / ₂ | 2 ¹ / ₄ | 3 ¹ / ₂ | 11 ¹ / ₈ | |
| | 3 ¹ / ₂ | 3 ¹ / ₄ -12 | 2 ¹ / ₂ -12 | 3 ¹ / ₂ | 4.249 | 1 | 3 | 3 ³ / ₈ | ¹ / ₂ | 1 ¹ / ₂ | 2 ¹ / ₄ | 3 ¹ / ₂ | 11 ¹ / ₈ | |
| | 4 | 3 ³ / ₄ -12 | 3-12 | 4 | 4.749 | 1 | 3 ³ / ₈ | 3 ⁷ / ₈ | ¹ / ₂ | 1 ¹ / ₂ | 2 ¹ / ₄ | 3 ¹ / ₂ | 11 ¹ / ₈ | |
| 12 | 4 ¹ / ₂ | 4 ¹ / ₄ -12 | 3 ¹ / ₄ -12 | 4 ¹ / ₂ | 5.249 | 1 | 3 ⁷ / ₈ | 4 ³ / ₈ | ¹ / ₂ | 1 ¹ / ₂ | 2 ¹ / ₄ | 3 ¹ / ₂ | 11 ⁵ / ₈ | |
| | 5 | 4 ³ / ₄ -12 | 3 ¹ / ₂ -12 | 5 | 5.749 | 1 | 4 ¹ / ₄ | 4 ⁷ / ₈ | ¹ / ₂ | 1 ¹ / ₂ | 2 ¹ / ₄ | 3 ¹ / ₂ | 11 ⁵ / ₈ | |
| | 5 ¹ / ₂ | 5 ¹ / ₄ -12 | 4-12 | 5 ¹ / ₂ | 6.249 | 1 | 4 ⁵ / ₈ | 5 ³ / ₈ | ¹ / ₂ | 1 ¹ / ₂ | 2 ¹ / ₄ | 3 ¹ / ₂ | 11 ⁵ / ₈ | |
| | 2 | 1 ³ / ₄ -12 | 1 ¹ / ₂ -12 | 2 ¹ / ₄ | 2.624 | ⁷ / ₈ | 1 ¹¹ / ₁₆ | 1 ¹⁵ / ₁₆ | ³ / ₈ | 1 ¹ / ₄ | 2 | 3 ¹ / ₄ | 11 ¹ / ₈ | |
| | 2 ¹ / ₂ | 2 ¹ / ₄ -12 | 1 ⁷ / ₈ -12 | 3 | 3.124 | 1 | 2 ¹ / ₁₆ | 2 ³ / ₈ | ¹ / ₂ | 1 ¹ / ₂ | 2 ¹ / ₄ | 3 ¹ / ₂ | 11 ⁵ / ₈ | |
| | 3 | 2 ³ / ₄ -12 | 2 ¹ / ₄ -12 | 3 ¹ / ₂ | 3.749 | 1 | 2 ⁵ / ₈ | 2 ⁷ / ₈ | ¹ / ₂ | 1 ¹ / ₂ | 2 ¹ / ₄ | 3 ¹ / ₂ | 11 ⁵ / ₈ | |
| | 3 ¹ / ₂ | 3 ¹ / ₄ -12 | 2 ¹ / ₂ -12 | 3 ¹ / ₂ | 4.249 | 1 | 3 | 3 ³ / ₈ | ¹ / ₂ | 1 ¹ / ₂ | 2 ¹ / ₄ | 3 ¹ / ₂ | 11 ⁵ / ₈ | |
| | 4 | 3 ³ / ₄ -12 | 3-12 | 4 | 4.749 | 1 | 3 ³ / ₈ | 3 ⁷ / ₈ | ¹ / ₂ | 1 ¹ / ₂ | 2 ¹ / ₄ | 3 ¹ / ₂ | 11 ⁵ / ₈ | |
| 14 | 4 ¹ / ₂ | 4 ¹ / ₄ -12 | 3 ¹ / ₄ -12 | 4 ¹ / ₂ | 5.249 | 1 | 3 ⁷ / ₈ | 4 ³ / ₈ | ¹ / ₂ | 1 ¹ / ₂ | 2 ¹ / ₄ | 3 ¹³ / ₁₆ | 13 ¹ / ₈ | |
| | 5 | 4 ³ / ₄ -12 | 3 ¹ / ₂ -12 | 5 | 5.749 | 1 | 4 ¹ / ₄ | 4 ⁷ / ₈ | ¹ / ₂ | 1 ¹ / ₂ | 2 ¹ / ₄ | 3 ¹³ / ₁₆ | 13 ¹ / ₈ | |
| | 5 ¹ / ₂ | 5 ¹ / ₄ -12 | 4-12 | 5 ¹ / ₂ | 6.249 | 1 | 4 ⁵ / ₈ | 5 ³ / ₈ | ¹ / ₂ | 1 ¹ / ₂ | 2 ¹ / ₄ | 3 ¹³ / ₁₆ | 13 ¹ / ₈ | |
| | 2 ¹ / ₂ | 2 ¹ / ₄ -12 | 1 ⁷ / ₈ -12 | 3 | 3.124 | 1 | 2 ¹ / ₁₆ | 2 ³ / ₈ | ¹ / ₂ | 1 ¹ / ₂ | 2 ¹ / ₄ | 3 ¹³ / ₁₆ | 13 ¹ / ₈ | |
| | 3 | 2 ³ / ₄ -12 | 2 ¹ / ₄ -12 | 3 ¹ / ₂ | 3.749 | 1 | 2 ⁵ / ₈ | 2 ⁷ / ₈ | ¹ / ₂ | 1 ¹ / ₂ | 2 ¹ / ₄ | 3 ¹³ / ₁₆ | 13 ¹ / ₈ | |
| | 3 ¹ / ₂ | 3 ¹ / ₄ -12 | 2 ¹ / ₂ -12 | 3 ¹ / ₂ | 4.249 | 1 | 3 | 3 ³ / ₈ | ¹ / ₂ | 1 ¹ / ₂ | 2 ¹ / ₄ | 3 ¹³ / ₁₆ | 13 ¹ / ₈ | |

Spherical Bearings for AV Cylinders Spherical Bearing Mount That Maintains Alignment Through Push and Pull Strokes.

Benefits Are...

- Simplify installation of cylinder
- Reduce cylinder friction
- Eliminate side loading in hard to align applications
- Increase cylinder life by reducing wear on piston and rod bearings
- Save assembly time
- Maintain alignment through push and pull strokes
- Increase rod bearing and rod seal life
- Simplify machine design problems



AV Series pneumatic cylinders are available with spherical bearing mounts at both ends or head and cap end only. The bearing at the cap end is housed in a single stud ear welded to the cap to form an integral structure. At the head end the bearing is mounted in a steel rod eye threaded to the piston rod. Grease fittings are provided for lubrication.

The spherical bearing mount provides swivel connections at both ends of the cylinder to reduce

misalignment problems and to maintain alignment through push and pull strokes.

The bearing races are designed primarily for radial loads and moderate misalignment not to exceed angle "a" as shown in Table 1 on the next page.

The accessories, rod eye, pivot pin and clevis brackets are all designed to take maximum loading of the cylinder.

Miller AV Series Heavy-Duty Air Cylinders

Spherical Bearing Mount
Application and Design Data and
Mounting Information

Application and Design Data

The spherical bearing life is influenced by many factors, i.e., bearing pressure, load direction, oscillating angle and lubrication. The 250 PSI operating pressure rating of the spherical bearing mountings is based on standard commercial bearing ratings.

The spherical bearings are dimensioned to ensure a satisfactory bearing life under normal operating conditions. The bearing races are made of through-hardened steel and are precision ground. They are phosphate treated and coated with dry film lubricant to minimize friction of contacting surfaces. In the case of a permanent unidirectional load to the bearing, or other unusual operating conditions, the use of a larger bearing may be required.

For longer bearing life, regular lubrication will protect the spherical plain bearing from premature wear and corrosion. Rust-inhibiting EP greases of lithium/lead base, preferably with molybdenum disulphide additives are particularly suited. The radial bearings have lubricating holes and grooves in the races permitting lubrication. The bearing housings at the cap and rod end are provided with grease fittings for lubrication.

Maximum angle of swivel in relation to the center line of the pivot pin is shown as angle a in the table below. It is recommended that this angle is not exceeded when mounting the cylinder.

Mounting Information

Head End Mounting

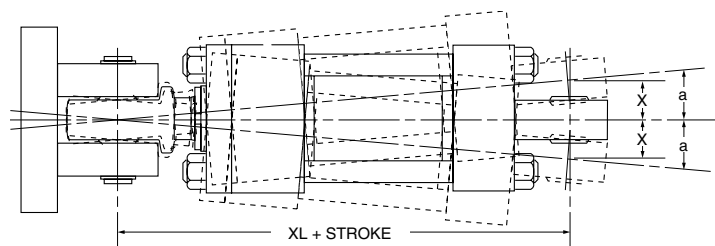

Recommended maximum swivel angle on each side of the cylinder centerline.

Table 1

| Bore | Head End Mounted | | Cap End Mounted | |
|--------|------------------|-------------|-----------------|-------------|
| | Angle a | Tan. of a | Angle a | Tan. of a |
| 1½ | 2° | .035 | 2° | .035 |
| 2 | 2½° | .044 | 4½° | .079 |
| 2½ | 2½° | .044 | 4½° | .079 |
| 3¼ | 3° | .052 | 3° | .052 |
| 4 | 2½° | .044 | 3° | .052 |
| 5 - 14 | 3° | .052 | 3° | .052 |

Note: Dimension X is the maximum off center mounting of the cylinder. To determine dimension X for various stroke lengths multiply distance between pivot pin holes by tangent of angle a . For extended position use $X = XL + 2X$ stroke.

Cap End Mounting

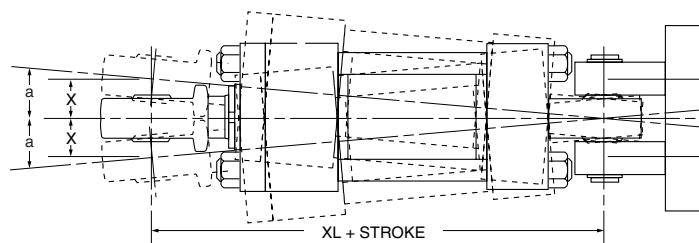

Miller AV Series Heavy-Duty Air Cylinders

Spherical Bearing Mount
1 1/2" to 14" Bore Sizes

Cap Fixed Eye Mount with Spherical Bearing Model 94

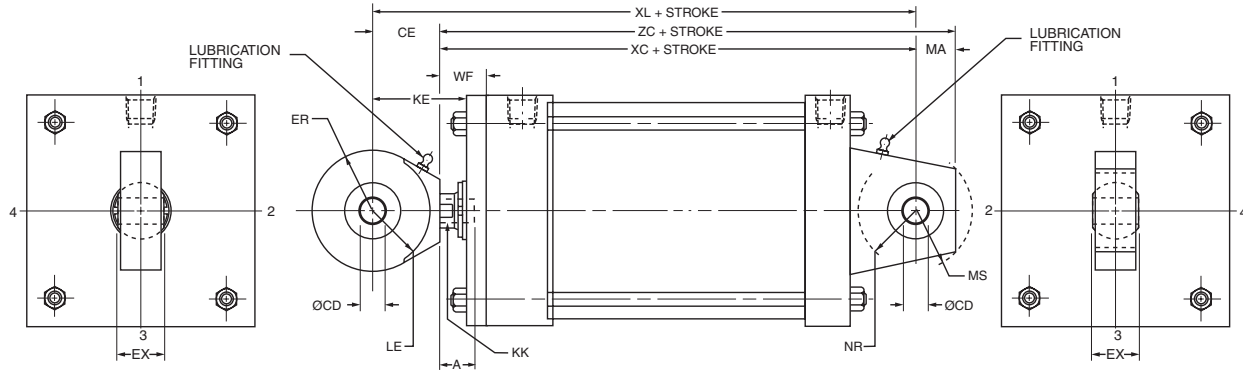

| Bore | MM Rod Ø | Thread** Style 4 KK | A | WF | Add Stroke | | | KE | CDØ* | CE | ER | EX | LE | MA | MS | NR | Max. Oper. PSI AV |
|-------|----------|---------------------------|-------|-------|------------|-------|-------|-------|------------------|-------|-------|--------|--------|-------|---------|-------|----------------------|
| | | | | | XC | XL | ZC | | | | | | | | | | |
| 1 1/2 | 5/8 | 7/16-20 | 3/4 | 1 | 5 3/8 | 6 1/4 | 6 1/8 | 1 1/2 | -.0005 .5000 | 7/8 | 13/16 | 7/16 | 3/4 | 3/4 | 15/16 | 5/8 | 250 |
| | 1 | 3/4-16 | 1 1/8 | 1 3/8 | 5 3/4 | 6 5/8 | 6 1/2 | 1 7/8 | | | | | | | | | |
| 2 | 5/8 | 7/16-20 | 3/4 | 1 | 5 3/8 | 6 1/4 | 6 1/8 | 1 1/2 | -.0005 .5000 | 7/8 | 13/16 | 7/16 | 3/4 | 3/4 | 15/16 | 5/8 | 250 |
| | 1 3/8 | 1-14 | 1 5/8 | 1 5/8 | 6 | 6 7/8 | 6 3/4 | 2 1/8 | | | | | | | | | |
| 2 1/2 | 5/8 | 7/16-20 | 3/4 | 1 | 5 3/8 | 6 1/4 | 6 1/8 | 1 1/2 | -.0005 .5000 | 7/8 | 13/16 | 7/16 | 3/4 | 3/4 | 15/16 | 5/8 | 250 |
| | 1 3/4 | 1 1/4-12 | 1 1/8 | 1 3/8 | 5 3/4 | 6 5/8 | 6 1/2 | 1 7/8 | | | | | | | | | |
| 3 1/4 | 1 | 3/4-16 | 1 1/8 | 1 3/8 | 6 7/8 | 8 1/8 | 7 7/8 | 2 | -.0005 .7500 | 1 1/4 | 1 1/8 | 2 1/32 | 1 1/16 | 1 | 1 3/8 | 1 | 250 |
| | 1 3/8 | 1-14 | 1 5/8 | 1 5/8 | 7 1/8 | 8 3/8 | 8 1/8 | 2 1/4 | | | | | | | | | |
| 4 | 1 | 3/4-16 | 1 1/8 | 1 3/8 | 6 7/8 | 8 1/8 | 7 7/8 | 2 | -.0005 .7500 | 1 1/4 | 1 1/8 | 2 1/32 | 1 1/16 | 1 | 1 3/8 | 1 | 250 |
| | 2 1/2 | 1 1/8-12 | 3 | 2 1/4 | 7 3/4 | 9 | 8 3/4 | 2 7/8 | | | | | | | | | |
| 5 | 1 3/8 | 1 1/4-12 | 2 | 1 7/8 | 7 3/8 | 8 5/8 | 8 3/8 | 2 1/2 | -.0005 .7500 | 1 1/4 | 1 1/8 | 2 1/32 | 1 1/16 | 1 | 1 3/8 | 1 | 250 |
| | 1 3/4 | 1 1/4-12 | 2 | 1 7/8 | 7 5/8 | 8 7/8 | 8 5/8 | 2 1/2 | | | | | | | | | |
| 6 | 2 | 1 1/2-12 | 2 1/4 | 2 | 7 3/4 | 9 | 8 3/4 | 2 5/8 | -.0005 1.0000 | 1 7/8 | 1 1/4 | 7/8 | 1 7/16 | 1 1/4 | 1 11/16 | 1 1/4 | 250 |
| | 2 1/2 | 1 7/8-12 | 3 | 2 1/4 | 8 | 9 1/4 | 9 | 2 7/8 | | | | | | | | | |

Maximum operating pressure is based on tensile strength of material. Pressure ratings are based on standard commercial bearing ratings.

*Dimension CD is hole diameter.

**To match pin diameter in rod eye and cap, when an oversize rod is required, specify rod end style 'X', 'KK' thread and 'A' thread length for the standard rod diameter (first rod listed for the bore), and 'W' for the oversize rod. Order the rod eye and clevis bracket for the required bore size from the tables on the Spherical Bearing Accessories page.

Miller AV Series Heavy-Duty Air Cylinders

Spherical Bearing Mount
Cylinder Accessories

Miller offers a complete range of Cylinder Accessories to assure you of the greatest versatility in present or future cylinder applications. Accessories offered for the

respective cylinder include the Rod Eye, Pivot Pin and Clevis Bracket. To select the proper part number for any desired accessory refer to the charts below.

Spherical Rod Eye

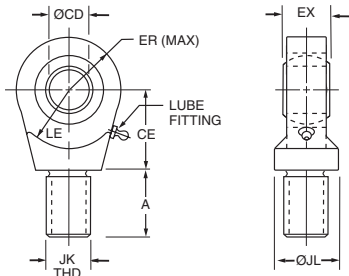

Order to fit Piston Rod Thread Size.

| Bore Sizes | 1 1/2, 2 & 2 1/2 | 3 1/4, 4 & 5 | 6 & 8 | 10 | 12 | 14 |
|--------------------|------------------------|------------------------|-------------------------|-------------------------|-------------------------|-------------------------|
| Part No. | 132290000 | 132291000 | 132292000 | 132293000 | 132294000 | 132295000 |
| CD Ø | .5000 ⁻⁰⁰⁰⁵ | .7500 ⁻⁰⁰⁰⁵ | 1.0000 ⁻⁰⁰⁰⁵ | 1.3750 ⁻⁰⁰⁰⁵ | 1.7500 ⁻⁰⁰⁰⁵ | 2.0000 ⁻⁰⁰⁰⁵ |
| A | 1 1/16 | 1 | 1 1/2 | 2 | 2 1/8 | 2 7/8 |
| CE | 7/8 | 1 1/4 | 1 7/8 | 2 1/8 | 2 1/2 | 2 3/4 |
| EX | 7/16 | 2 1/32 | 7/8 | 1 3/16 | 1 17/32 | 1 3/4 |
| ER | 7/8 | 1 1/4 | 1 3/8 | 1 13/16 | 2 3/16 | 2 5/8 |
| LE | 3/4 | 1 1/16 | 1 7/16 | 1 7/8 | 2 1/8 | 2 1/2 |
| JK | 7/16-20 | 3/4-16 | 1-14 | 1 1/4-12 | 1 1/2-12 | 1 7/8-12 |
| JL | 7/8 | 1 5/16 | 1 1/2 | 2 | 2 1/4 | 2 3/4 |
| LOAD CAPACITY LBS. | 2644 | 9441 | 16860 | 28562 | 43005 | 70193 |

Pivot Pin

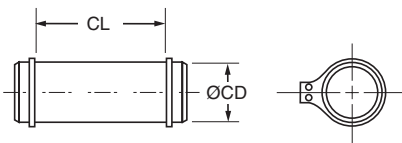

Pivot Pins are furnished with (2) Retainer Rings.

| Bore Sizes | 1 1/2, 2 & 2 1/2 | 3 1/4, 4 & 5 | 6 & 8 | 10 | 12 | 14 |
|--------------------|------------------------|------------------------|------------------------|-------------------------|-------------------------|-------------------------|
| Part No. | 083962000 | 083963000 | 083964000 | 083965000 | 083966000 | 083967000 |
| CD Ø | .4997 ⁻⁰⁰⁰⁴ | .7497 ⁻⁰⁰⁰⁵ | .9997 ⁻⁰⁰⁰⁵ | 1.3746 ⁻⁰⁰⁰⁶ | 1.7596 ⁻⁰⁰⁰⁶ | 1.9996 ⁻⁰⁰⁰⁷ |
| CL | 1 9/16 | 2 1/32 | 2 1/2 | 3 5/16 | 4 7/32 | 4 15/16 |
| LOAD CAPACITY LBS. | 8600 | 19300 | 34300 | 65000 | 105200 | 137400 |

Clevis Bracket

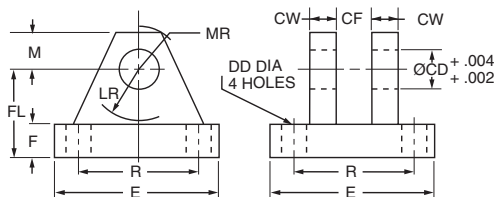

Order to fit Cap or Rod Eye.

| Bore Sizes | 1 1/2, 2 & 2 1/2 | 3 1/4, 4 & 5 | 6 & 8 | 10 | 12 | 14 |
|--------------------|------------------|--------------|-----------|-----------|-----------|-----------|
| Part No. | 083947000 | 083948000 | 083949000 | 083950000 | 083951000 | 083952000 |
| CD Ø | 1 1/2 | 3/4 | 1 | 1 3/8 | 1 3/4 | 2 |
| CF | 7/16 | 2 1/32 | 7/8 | 1 3/16 | 1 17/32 | 1 3/4 |
| CW | 1/2 | 5/8 | 3/4 | 1 | 1 1/4 | 1 1/2 |
| DD | 13/32 | 13/32 | 17/32 | 2 1/32 | 2 9/32 | 2 9/32 |
| E | 3 | 3 3/4 | 5 1/2 | 6 1/2 | 8 1/2 | 10 5/8 |
| F | 1/2 | 5/8 | 3/4 | 7/8 | 1 1/4 | 1 1/2 |
| FL | 1 1/2 | 2 | 2 1/2 | 3 1/2 | 4 1/2 | 5 |
| LR | 1 5/16 | 1 3/8 | 1 11/16 | 2 7/16 | 2 7/8 | 3 5/16 |
| M | 1/2 | 7/8 | 1 | 1 3/8 | 1 3/4 | 2 |
| MR | 5/8 | 1 | 1 3/16 | 1 5/8 | 2 1/16 | 2 3/8 |
| R | 2.05 | 2.76 | 4.10 | 4.95 | 6.58 | 7.92 |
| LOAD CAPACITY LBS. | 5770 | 9450 | 14300 | 20322 | 37800 | 50375 |

Miller AVN Series Heavy-Duty Air Cylinders

AVN Series
Non-Lube

Miller Fluid Power Non-Lube Heavy-Duty Air Cylinders

AVN Series



For millions of trouble free cycles

- Nominal pressure — 250 PSI — Air Service
- Standard Bore Sizes — 1½" through 14"
- Piston Rod Diameters — 5⁄8" through 5½"
- 17 Standard Mounting Styles
- NFPA Interchangeable

Miller AVN Series Heavy-Duty Air Cylinders

AVN Series
Non-Lube

The AVN Series Non-Lube Air Cylinder with Proven Performance Millions of trouble free cycles with... **ZERO LEAKAGE.**

Piston Lipseals

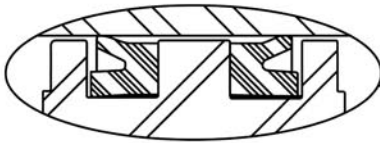

Rod Seal & Rod Wiper

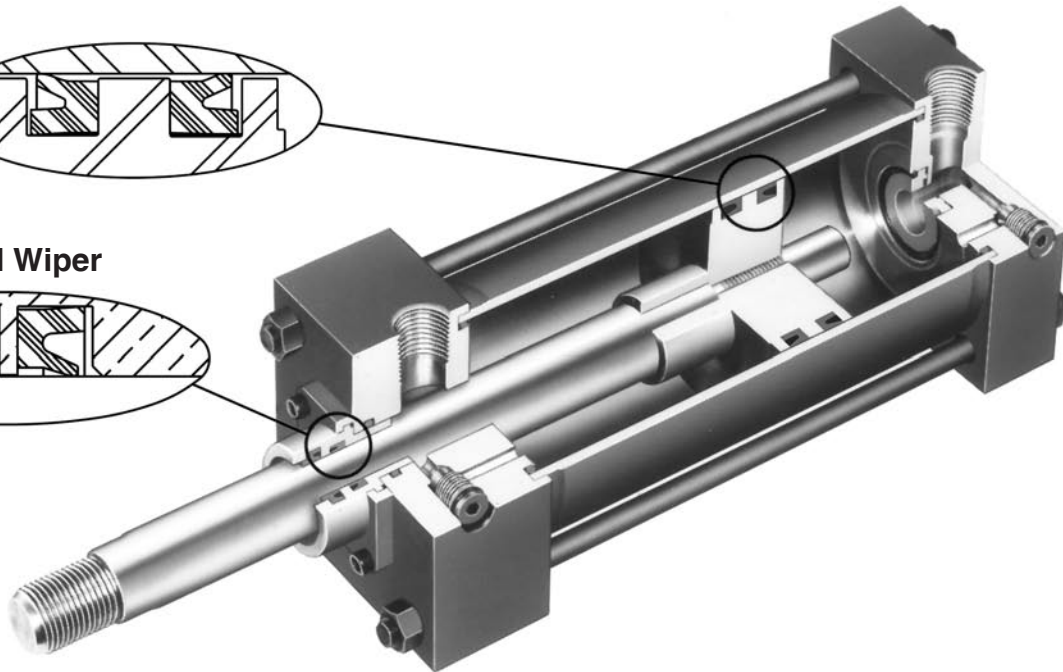

Increased Market Demand, continuous research, and testing efforts inspired the development of the AVN Series Non-Lubricated Air Cylinder. The AVN Series piston rod and cylinder tube surfaces act as highly efficient lubricant reservoirs, maintaining their own lubricant film. Other manufacturers pack grease into grooves and pockets and call them reservoirs. The fact of the matter is that as those grooves empty out over time; grease is being transported out of the cylinder and into the control system components and the atmosphere. The AVN Series concept eliminates that problem by maintaining the lubricant film where it belongs: on the seals, bearing surfaces, piston rod and cylinder bore.

Benefits include...long seal and bearing life and since no oil is added through the use of lubricators – no oil is expelled into the atmosphere with the exhaust air as the cylinder strokes.

Anatomy of AVN Series Sealing and Lubricant Retention Systems

Rounded sealing lip glides over lubricant film instead of scraping it off. Reduces friction, increases life and eliminates the need for added lubrication.

Increased heel thickness and outer lip extension improve stability, resist rolling.

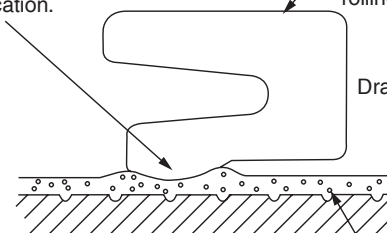

Drawing not to scale

High integrity lubricant film with suspended PTFE particles

Miller AVN Series Heavy-Duty Air Cylinders

AVN Series
Specifications
How to Order

In the AVN Series you get all the cost saving benefits and features of the heavy-duty AV Series air cylinder including...

- Bolted Bushing Assembly for positive no leak sealing
 - Piston rod, hard chrome-plated and case-hardened steel
 - High strength rolled thread Piston Rod Stud
 - Steel tube with chrome-plated micro finish bore...
- Plus** the innovative “Non-Lube” feature which further increases your benefits of lower operating and maintenance costs.

Standard Specifications

- Heavy-Duty Service — ANSI/(NFPA) T3.6.7 R2-1996 Mounting Dimension Standards
- Standard Construction — Square Head — Tie Rod Design
- Standard Temperature — 10°F to +165°F
- Standard Fluid — Filtered Air
- Strokes — Available in any practical stroke length
- Cushions — Optional at either end or both ends of stroke. “Float Check” at cap end.

In line with our policy of continuing product improvement, specifications in this bulletin are subject to change.

Available Bore and Rod Sizes

| | | | | | | | | | | | |
|-----------------------------|-----|----|-----|-----|----|----|----|----|-----|-----|-----|
| Bore Sizes Available | 1½" | 2" | 2½" | 3¼" | 4" | 5" | 6" | 8" | 10" | 12" | 14" |
|-----------------------------|-----|----|-----|-----|----|----|----|----|-----|-----|-----|

| | | | | | | | | | | | | |
|----------------------------|------|----|-----|-----|----|-----|----|-----|----|-----|----|-----|
| Rod Sizes Available | 5/8" | 1" | 1¾" | 1¾" | 2" | 2½" | 3" | 3½" | 4" | 4½" | 5" | 5½" |
|----------------------------|------|----|-----|-----|----|-----|----|-----|----|-----|----|-----|

How to Order AVN Series Non-Lube Air Cylinders

Data Required on all AVN Cylinder Orders

When ordering AVN Series cylinders, be sure to specify each of the following requirements:

(**Note:** Duplicate cylinders can be ordered by giving the SERIAL NUMBER from the original cylinder. Factory records supply a quick, positive identification.)

a) Bore Size

b) Mounting Style

Specify your choice of mounting style — as shown in this catalog.

c) Series Designation (AVN)

d) Length of Stroke

e) Piston Rod Diameter

Specify rod diameter, standard rod diameters will be furnished if not otherwise specified, unless length of stroke makes the application questionable.

f) Piston Rod End Thread Style

Give thread style number or specify dimensions. Thread style number 2 will be supplied if not otherwise specified.

g) Cushions (if required)

Specify “Cushion-rod end,” “Cushion-cap end” or “Cushion-both ends” as required. If cylinder is to have a double rod and only one cushion is required, be sure to specify clearly which end of the cylinder is to be cushioned.

Miller AV Series Heavy-Duty Air Cylinders

Cylinder
Accessories

Cylinder Accessories

Miller offers a complete range of cylinder accessories to assure you of the greatest versatility in present and future cylinder applications.

Rod End Accessories

Accessories offered for the rod end of the cylinder include Rod Clevis, Eye Bracket, Rod Eye, Clevis Bracket, and Pivot Pin. To select the proper part number for any desired accessory, refer to the table below or on the opposite page and look in the row to the right of the rod thread in the first column. For economical accessory selection, it is recommended that rod end style 2 be specified on your cylinder order.

Accessory Load Capacity

The various accessories have been load rated for your convenience. The load Capacity in lbs. Is the recommended maximum load for that accessory based on a 4:1 design factor in tension. (Pivot Pin is rated in shear.) Before specifying, compare the actual load or the tension (pull) force at maximum operating pressure of the cylinder with the load capacity of the accessory you plan to use. If load or pull force of cylinder exceeds load capacity of accessory, consult factory.

| Thread Size | Rod Clevis | | Eye Bracket | | Pivot Pin | |
|-------------|-------------|----------------------|-------------|----------------------|-------------|-----------------------|
| | Part Number | Load Capacity (Lbs.) | Part Number | Load Capacity (Lbs.) | Part Number | Shear Capacity (Lbs.) |
| 5/16-24 | 0512210000† | 2600 | 0740770000 | 1700 | — | — |
| 7/16-20 | 0509400000 | 4250 | 0691950000 | 4100 | 0683680000 | 8600 |
| 1/2-20 | 0509410000 | 4900 | 0691950000 | 4100 | 0683680000 | 8600 |
| 3/4-16 | 0509420000 | 11200 | 0691960000 | 10500 | 0683690000 | 19300 |
| 3/4-16 | 1332840000 | 11200 | 0691960000 | 10500 | 0683690000 | 19300 |
| 7/8-14 | 0509430000 | 18800 | *0853610000 | 20400 | 0683700000 | 34300 |
| 1-14 | 0509440000 | 19500 | *0853610000 | 20400 | 0683700000 | 34300 |
| 1-14 | 1332850000 | 19500 | *0853610000 | 20400 | 0683700000 | 34300 |
| 1 1/4-12 | 0509450000 | 33500 | 0691980000 | 21200 | 0683710000 | 65000 |
| 1 1/4-12 | 1332860000 | 33500 | 0691980000 | 21200 | 0683710000 | 65000 |
| 1 1/2-12 | 0509460000 | 45600 | *0853620000 | 49480 | 0683720000 | 105200 |
| 1 3/4-12 | 0509470000 | 65600 | *0853630000 | 70000 | 0683730000 | 137400 |
| 1 7/8-12 | 0509480000 | 65600 | *0853630000 | 70000 | 0683730000 | 137400 |
| 2 1/4-12 | 0509490000 | 98200 | *0853640000 | 94200 | 0683740000 | 214700 |
| 2 1/2-12 | 0509500000 | 98200 | *0853650000 | 121900 | 0683750000 | 309200 |
| 2 3/4-12 | 0509510000 | 98200 | *0853650000 | 121900 | 0683750000 | 309200 |
| 3 1/4-12 | 0509520000 | 156700 | 0735380000 | 57400 | 0735450000 | 420900 |
| 3 1/2-12 | 0509530000 | 193200 | 0735390000 | 75000 | 0735470000 | 565800 |
| 4-12 | 0509540000 | 221200 | 0735390000 | 75000 | 0735470000 | 565800 |

† Includes pivot pin.

* Cylinder accessory dimensions conform to NFPA recommended standard NFPA/T3.6.8 R1-1984, NFPA recommended standard fluid power systems – cylinder – dimensions for accessories for cataloged square head industrial cylinders.

Miller AV Series Heavy-Duty Air Cylinders

Cylinder
Accessories

Rod Clevis Dimensions

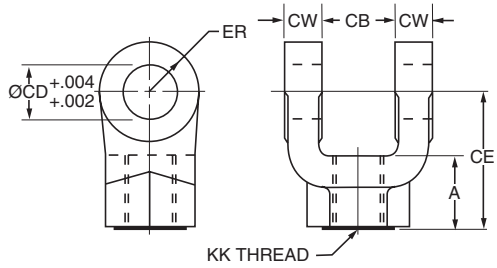

Pivot Pin Dimensions

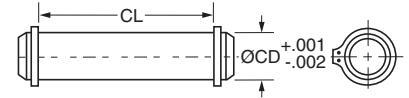

| Part Number | A | CB | CD Ø | CE | CW | ER | KK |
|-------------|---------|-------|-------|---------|-------|-------|----------|
| 0512210000† | 13/16 | 11/32 | 5/16 | 2 1/4 | 13/64 | 19/64 | 5/16-24 |
| 0509400000 | 3/4 | 3/4 | 1/2 | 1 1/2 | 1/2 | 1/2 | 7/16-20 |
| 0509410000 | 3/4 | 3/4 | 1/2 | 1 1/2 | 1/2 | 1/2 | 1/2-20 |
| 0509420000 | 1 1/8 | 1 1/4 | 3/4 | 2 1/8 | 5/8 | 3/4 | 3/4-16 |
| 1332840000 | 1 1/8 | 1 1/4 | 3/4 | 2 3/8 | 5/8 | 3/4 | 3/4-16 |
| 0509430000 | 1 5/8 | 1 1/2 | 1 | 2 15/16 | 3/4 | 1 | 7/8-14 |
| 0509440000 | 1 5/8 | 1 1/2 | 1 | 2 15/16 | 3/4 | 1 | 1-14 |
| 1332850000 | 1 5/8 | 1 1/2 | 1 | 3 1/8 | 3/4 | 1 | 1-14 |
| 0509450000 | 1 7/8 | 2 | 1 3/8 | 3 3/4 | 1 | 1 3/8 | 1 1/4-12 |
| 1332860000 | 2 | 2 | 1 3/8 | 4 1/8 | 1 | 1 3/8 | 1 1/4-12 |
| 0509460000 | 2 1/4 | 2 1/2 | 1 3/4 | 4 1/2 | 1 1/4 | 1 3/4 | 1 1/2-12 |
| 0509470000 | 3 | 2 1/2 | 2 | 5 1/2 | 1 1/4 | 2 | 1 3/4-12 |
| 0509480000 | 3 | 2 1/2 | 2 | 5 1/2 | 1 1/4 | 2 | 1 7/8-12 |
| 0509490000 | 3 1/2 | 3 | 2 1/2 | 6 1/2 | 1 1/2 | 2 1/2 | 2 1/4-12 |
| 0509500000 | 3 1/2 | 3 | 3 | 6 3/4 | 1 1/2 | 2 3/4 | 2 1/2-12 |
| 0509510000 | 3 1/2 | 3 | 3 | 6 3/4 | 1 1/2 | 2 3/4 | 2 3/4-12 |
| 0509520000 | 3 1/2 ‡ | 4 | 3 1/2 | 7 3/4 | 2 | 3 1/2 | 3 1/4-12 |
| 0509530000 | 4 ‡ | 4 1/2 | 4 | 8 13/16 | 2 1/4 | 4 | 3 1/2-12 |
| 0509540000 | 4 ‡ | 4 1/2 | 4 | 8 13/16 | 2 1/4 | 4 | 4-12 |

| Part Number | CD Ø | CL |
|-------------|-------|--------|
| 0683680000 | 1/2 | 1 7/8 |
| 0683690000 | 3/4 | 2 5/8 |
| 0683700000 | 1 | 3 1/8 |
| 0683710000 | 1 3/8 | 4 1/8 |
| 0683720000 | 1 3/4 | 5 3/16 |
| 0683730000 | 2 | 5 3/16 |
| 0683740000 | 2 1/2 | 6 3/16 |
| 0683750000 | 3 | 6 1/4 |
| 0735450000 | 3 1/2 | 8 1/4 |
| 0735470000 | 4 | 9 |

1. Pivot Pins are furnished with Clevis Mounted Cylinders as standard.
2. Pivot Pins are furnished with (2) Retainer Rings.
3. Pivot Pins must be ordered as a separate item if to be used with Rod Eyes, Rod Clevises, or Clevis Brackets.

‡Consult appropriate cylinder rod end dimensions for compatibility.

Eye Bracket Dimensions

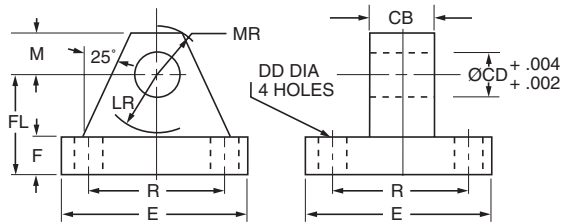

1. When used to mate with the Rod Clevis, select by thread size in table on opposite page.
2. When used to mount the Model 84 Cylinders, select by bore size below.

| Part Number | CB | CD Ø | DD | E | F | FL | LR | M | MR | R | Bore |
|-------------|-------|-------|---------|--------|---------|---------|-------|-------|--------|-------|------------|
| 0740770000 | 5/16 | 5/16 | 17/64 | 2 1/4 | 3/8 | 1 | 5/8 | 3/8 | 1/2 | 1.75 | — |
| 0691950000 | 3/4 | 1/2 | 13/32 | 2 1/2 | 3/8 | 1 1/8 | 3/4 | 1/2 | 9/16 | 1.63 | 1 1/2" |
| 0691960000 | 1 1/4 | 3/4 | 17/32 | 3 1/2 | 5/8 | 1 7/8 | 1 1/4 | 3/4 | 7/8 | 2.55 | 2", 2 1/2" |
| *0853610000 | 1 1/2 | 1 | 21/32 | 4 1/2 | 7/8 | 2 3/8 | 1 1/2 | 1 | 1 1/4 | 3.25 | 3 1/4" |
| 0691980000 | 2 | 1 5/8 | 21/32 | 5 | 7/8 | 3 | 2 1/8 | 1 3/8 | 1 5/8 | 3.82 | 4" |
| *0853620000 | 2 1/2 | 1 3/4 | 29/32 | 6 1/2 | 1 1/8 | 3 3/8 | 2 1/4 | 1 3/4 | 2 1/8 | 4.95 | 5" |
| *0853630000 | 2 1/2 | 2 | 1 1/16 | 7 1/2 | 1 1/2 | 4 | 2 1/2 | 2 | 2 7/16 | 5.73 | 6" |
| *0853640000 | 3 | 2 1/2 | 1 3/16 | 8 1/2 | 1 3/4 | 4 3/4 | 3 | 2 1/2 | 3 | 6.58 | 7" |
| *0853650000 | 3 | 3 | 1 5/16 | 9 1/2 | 2 | 5 1/4 | 3 1/4 | 2 3/4 | 3 1/4 | 7.50 | 8" |
| 0735380000 | 4 | 3 1/2 | 1 13/16 | 12 5/8 | 1 11/16 | 5 11/16 | 4 | 3 1/2 | 4 1/8 | 9.62 | — |
| 0735390000 | 4 1/2 | 4 | 2 1/16 | 14 7/8 | 1 15/16 | 6 7/16 | 4 1/2 | 4 | 5 1/4 | 11.45 | — |

† Includes Pivot Pin

* Cylinder accessory dimensions conform to NFPA recommended standard NFPA/T3.6.8 R1-1984, NFPA recommended standard fluid power systems - cylinder - dimensions for accessories for cataloged square head industrial cylinders.

Miller AV Series Heavy-Duty Air Cylinders

Cylinder
Accessories

Rod End Accessories

Accessories offered for the rod end of the cylinder include Rod Clevis, Eye Bracket, Rod Eye, Clevis Bracket, and Pivot Pin. To select the proper part number for any desired accessory, refer to the table below or on the opposite page and look in the row to the right of the rod thread in the first column. For economical accessory selection, it is recommended that rod end style 2 be specified on your cylinder order.

Accessory Load Capacity

The various accessories have been load rated for your convenience. The load Capacity in lbs. is the recommended maximum load for that accessory based on a 4:1 design factor in tension. (Pivot Pin is rated in shear.) Before specifying, compare the actual load or the tension (pull) force at the maximum operating pressure of the cylinder with the load capacity of the accessory you plan to use. If load or pull force of cylinder exceeds load capacity of accessory, consult factory.

| Thread Size | Rod Eye | | Clevis Bracket | | Pivot Pin | |
|-------------|-------------|----------------------|----------------|----------------------|-------------|-----------------------|
| | Part Number | Load Capacity (Lbs.) | Part Number | Load Capacity (Lbs.) | Part Number | Shear Capacity (Lbs.) |
| 5/16-24 | 0740750000 | 3300 | 0740760000 | 3600 | 0740780000 | 6600 |
| 7/16-20 | 0690890000 | 5000 | 0692050000 | 7300 | 0683680000 | 8600 |
| 1/2-20 | 0690900000 | 5700 | 0692050000 | 7300 | 0683680000 | 8600 |
| 3/4-16 | 0690910000 | 12100 | 0692060000 | 14000 | 0683690000 | 19300 |
| 3/4-16 | 0690910000 | 12100 | 0692060000 | 14000 | 0683690000 | 19300 |
| 7/8-14 | 0690920000 | 13000 | 0692070000 | 19200 | 0683700000 | 34300 |
| 1-14 | 0690930000 | 21700 | 0692070000 | 19200 | 0683700000 | 34300 |
| 1-14 | 0690930000 | 21700 | 0692070000 | 19200 | 0683700000 | 34300 |
| 1 1/4-12 | 0690940000 | 33500 | 0692080000 | 36900 | 0683710000 | 65000 |
| 1 1/4-12 | 0690940000 | 33500 | 0692080000 | 36900 | 0683710000 | 65000 |
| 1 1/2-12 | 0690950000 | 45000 | 0692090000 | 34000 | 0683720000 | 105200 |
| 1 3/4-12 | 0690960000 | 53500 | 0692100000 | 33000 | 0692150000 | 137400 |
| 1 7/8-12 | 0690970000 | 75000 | 0692100000 | 33000 | 0692150000 | 137400 |
| 2 1/4-12 | 0690980000 | 98700 | 0692110000 | 34900 | 0683740000 | 214700 |
| 2 1/2-12 | 0690990000 | 110000 | 0692120000 | 33800 | 0683750000 | 309200 |
| 2 3/4-12 | 0691000000 | 123300 | 0692130000 | 36900 | 0692160000 | 309200 |
| 3 1/4-12 | 0735360000 | 161300 | 0735420000 | 83500 | 0735450000 | 420900 |
| 3 1/2-12 | 0734370000 | 217300 | 0735420000 | 83500 | 0735450000 | 420900 |
| 4-12 | 0734380000 | 273800 | 0735430000 | 102600 | 0821810000 | 565800 |
| 4 1/2-12 | 0734390000 | 308500 | 0735440000 | 108400 | 0735470000* | 565800 |

* This size supplied with cotter pins.

Miller AV Series Heavy-Duty Air Cylinders

Cylinder
Accessories

Rod Eye Dimensions

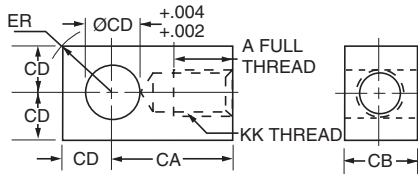

| Part Number | A | CA | CB | CD | ER | KK |
|-------------|-------|---------|-------|-------|---------|----------|
| 0740750000 | 3/4 | 1 1/2 | 7/16 | 7/16 | 19/32 | 5/16-24 |
| 0690890000 | 3/4 | 1 1/2 | 3/4 | 1/2 | 23/32 | 7/16-20 |
| 0690900000 | 3/4 | 1 1/2 | 3/4 | 1/2 | 23/32 | 1/2-20 |
| 0690910000 | 1 1/8 | 2 1/16 | 1 1/4 | 3/4 | 1 1/16 | 3/4-16 |
| 0690920000 | 1 1/8 | 2 3/8 | 1 1/2 | 1 | 1 7/16 | 7/8-14 |
| 0690930000 | 1 5/8 | 2 13/16 | 1 1/2 | 1 | 1 7/16 | 1-14 |
| 0690940000 | 2 | 3 7/16 | 2 | 1 3/8 | 1 31/32 | 1 1/4-12 |
| 0690950000 | 2 1/4 | 4 | 2 1/2 | 1 3/4 | 2 1/2 | 1 1/2-12 |
| 0690960000 | 2 1/4 | 4 3/8 | 2 1/2 | 2 | 2 27/32 | 1 3/4-12 |
| 0690970000 | 3 | 5 | 2 1/2 | 2 | 2 27/32 | 1 7/8-12 |
| 0690980000 | 3 1/2 | 5 13/16 | 3 | 2 1/2 | 3 9/16 | 2 1/4-12 |
| 0690990000 | 3 1/2 | 6 1/8 | 3 | 3 | 4 1/4 | 2 1/2-12 |
| 0691000000 | 3 5/8 | 6 1/2 | 3 1/2 | 3 | 4 1/4 | 2 3/4-12 |
| 0735360000 | 4 1/2 | 7 5/8 | 4 | 3 1/2 | 4 31/32 | 3 1/4-12 |
| 0734370000 | 5 | 7 5/8 | 4 | 3 1/2 | 4 31/32 | 3 1/2-12 |
| 0734380000 | 5 1/2 | 9 1/8 | 4 1/2 | 4 | 5 11/16 | 4-12 |
| 0734390000 | 5 1/2 | 9 1/8 | 5 | 4 | 5 11/16 | 4 1/2-12 |

Pivot Pin Dimensions

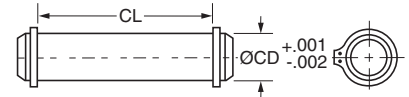

| Part Number | CD Ø | CL |
|-------------|-------|---------|
| 0740780000 | 7/16 | 1 5/16 |
| 0683680000 | 1/2 | 1 7/8 |
| 0683690000 | 3/4 | 2 5/8 |
| 0683700000 | 1 | 3 1/8 |
| 0683710000 | 1 3/8 | 4 1/8 |
| 0683720000 | 1 3/4 | 5 3/16 |
| 0692150000 | 2 | 5 11/16 |
| 0683740000 | 2 1/2 | 6 3/16 |
| 0683750000 | 3 | 6 1/4 |
| 0692160000 | 3 | 6 3/4 |
| 0735450000 | 3 1/2 | 8 1/4 |
| 0821810000 | 4 | 8 5/8 |
| 0735470000* | 4 | 9 |

- Pivot Pins are furnished with Clevis Mounted Cylinders as standard.
- Pivot Pins are furnished with (2) Retainer Rings.
- Pivot Pins must be ordered as a separate item if to be used with Rod Eyes, Rod Clevises, or Clevis Brackets.

Clevis Bracket Dimensions

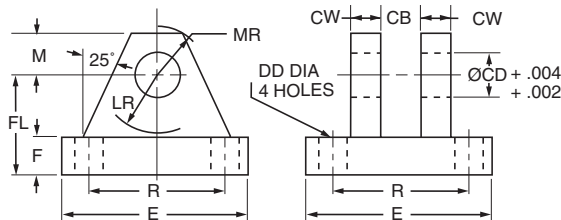

| Part Number | CB | CD Ø | CW | DD | E | F | FL | LR | M | MR | R |
|-------------|-------|-------|-------|---------|--------|---------|---------|--------|-------|---------|-------|
| 0740760000 | 15/32 | 7/16 | 3/8 | 17/64 | 2 1/4 | 3/8 | 1 | 5/8 | 3/8 | 1/2 | 1.75 |
| 0692050000 | 3/4 | 1/2 | 1/2 | 13/32 | 3 1/2 | 1/2 | 1 1/2 | 3/4 | 1/2 | 5/8 | 2.55 |
| 0692060000 | 1 1/4 | 3/4 | 5/8 | 17/32 | 5 | 5/8 | 1 7/8 | 1 3/16 | 3/4 | 29/32 | 3.82 |
| 0692070000 | 1 1/2 | 1 | 3/4 | 21/32 | 6 1/2 | 3/4 | 2 1/4 | 1 1/2 | 1 | 1 1/4 | 4.95 |
| 0692080000 | 2 | 1 3/8 | 1 | 21/32 | 7 1/2 | 7/8 | 3 | 2 | 1 3/8 | 1 21/32 | 5.73 |
| 0692090000 | 2 1/2 | 1 3/4 | 1 1/4 | 29/32 | 9 1/2 | 7/8 | 3 5/8 | 2 3/4 | 1 3/4 | 2 7/32 | 7.50 |
| 0692100000 | 2 1/2 | 2 | 1 1/2 | 1 1/16 | 12 3/4 | 1 | 4 1/4 | 3 3/16 | 2 1/4 | 2 25/32 | 9.40 |
| 0692110000 | 3 | 2 1/2 | 1 1/2 | 1 3/16 | 12 3/4 | 1 | 4 1/2 | 3 1/2 | 2 1/2 | 3 1/8 | 9.40 |
| 0692120000 | 3 | 3 | 1 1/2 | 1 5/16 | 12 3/4 | 1 | 6 | 4 1/4 | 3 | 3 19/32 | 9.40 |
| 0692130000 | 3 1/2 | 3 | 1 1/2 | 1 5/16 | 12 3/4 | 1 | 6 | 4 1/4 | 3 | 3 19/32 | 9.40 |
| 0735420000 | 4 | 3 1/2 | 2 | 1 13/16 | 15 1/2 | 1 11/16 | 6 11/16 | 5 | 3 1/2 | 4 1/8 | 12.00 |
| 0735430000 | 4 1/2 | 4 | 2 | 2 1/16 | 17 1/2 | 1 15/16 | 7 11/16 | 5 3/4 | 4 | 4 7/8 | 13.75 |
| 0735440000 | 5 | 4 | 2 | 2 1/16 | 17 1/2 | 1 15/16 | 7 11/16 | 5 3/4 | 4 | 4 7/8 | 13.75 |

Cylinder accessory dimensions conform to NFPA recommended standard NFPT/T3.6.8 R1-1984, NFPA recommended standard fluid power systems - cylinder - dimensions for accessories for cataloged square head industrial cylinders.

- This size supplied with cotter pins.

Miller AV Series Heavy-Duty Air Cylinders

Piston Rod End
"Style 9"

Miller "Style 9" Piston Rod End Split Flange Coupling Rod End

- Simplifies alignment
- Reduces assembly time
- Available in 5/8" through 5-1/2" piston rod diameters

Style 9 Rod End

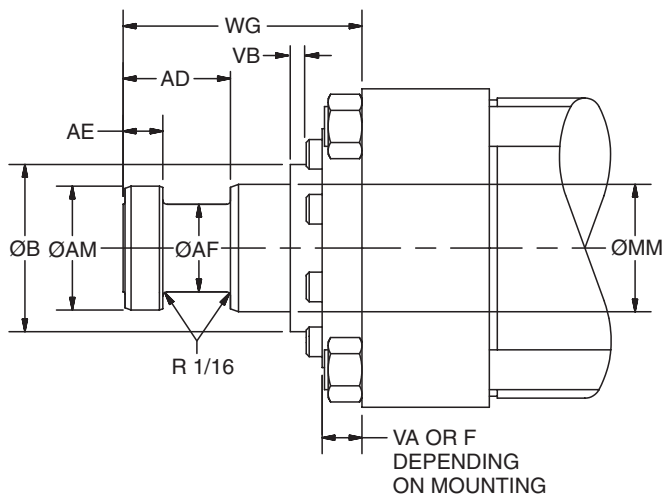

Dimensions Style 9 Rod End

| MM Rod Ø | AD | AE | AF Ø | AM Ø | WG |
|----------|---------|-------|-------|------|-------|
| 5/8 | 5/8 | 1/4 | 3/8 | .57 | 1 3/4 |
| 1 | 15/16 | 3/8 | 11/16 | .95 | 2 3/8 |
| 1 3/8 | 1 1/16 | 3/8 | 7/8 | 1.32 | 2 3/4 |
| 1 3/4 | 1 5/16 | 1/2 | 1 1/8 | 1.70 | 3 1/8 |
| 2 | 1 11/16 | 5/8 | 1 3/8 | 1.95 | 3 3/4 |
| 2 1/2 | 1 15/16 | 3/4 | 1 3/4 | 2.45 | 4 1/2 |
| 3 | 2 7/16 | 7/8 | 2 1/4 | 2.95 | 5 |
| 3 1/2 | 2 11/16 | 1 | 2 1/2 | 3.45 | 5 5/8 |
| 4 | 2 11/16 | 1 | 3 | 3.95 | 5 3/4 |
| 5 | 3 3/16 | 1 1/2 | 3 7/8 | 4.95 | 6 5/8 |
| 5 1/2 | 3 15/16 | 1 7/8 | 4 3/8 | 5.45 | 7 1/2 |

See previous catalog pages for B, F, G, VA, and VB per bore and rod diameter.

Miller AV Series Heavy-Duty Air Cylinders

Piston Rod End
"Style 9"

"Style 9" Piston Rod End Split Couplers and Weld Plates

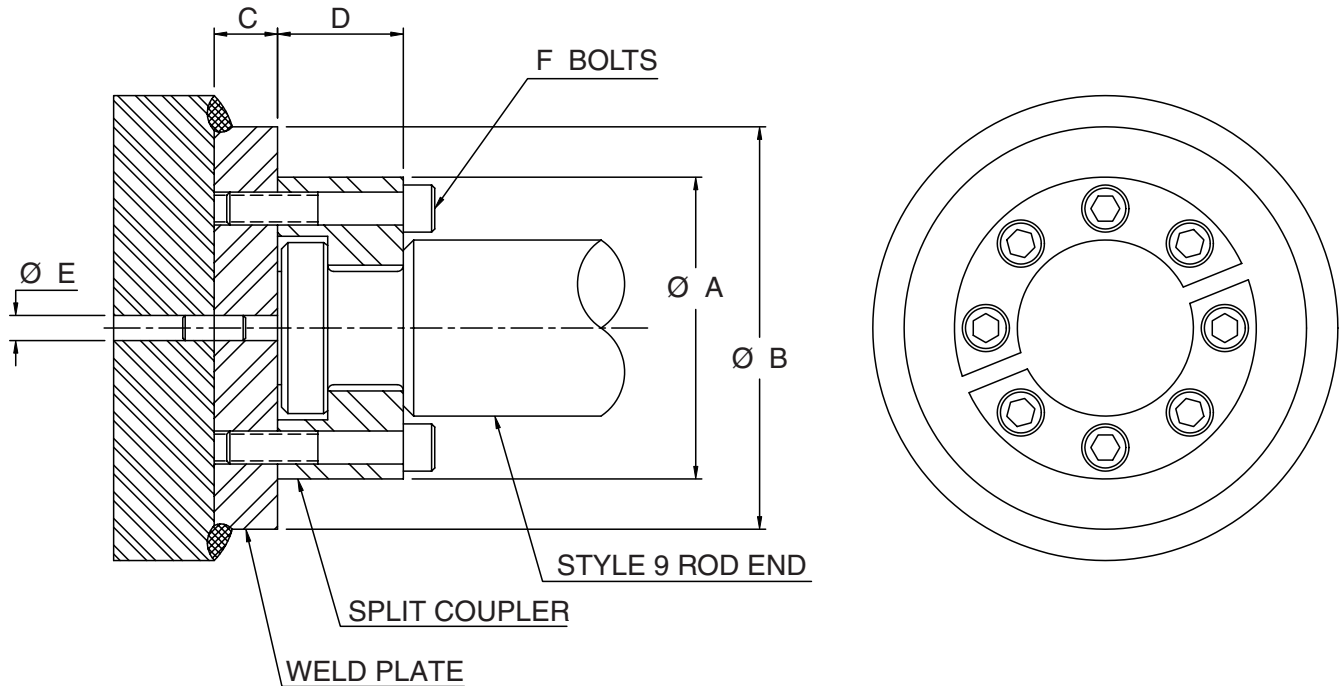

⚠ WARNING: Piston rod separation from the machine member can result in severe personal injury or even death to nearby personnel. The cylinder user must make sure the weld holding the weld plate to the machine is of sufficient quality and size to hold the intended load. The cylinder user must also make sure the bolts holding split coupler to the weld plate are of sufficient strength to hold the intended load and installed in such a way that they will not become loose during the machine's operation.

Table 1 — Part Numbers and Dimensions

| ROD Ø | A Ø | B Ø | C | D | E Ø | F | BOLT SIZE | BOLT CIRCLE | SPLIT COUPLER PART NO. | WELD PLATE PART NO. |
|-------|------|------|------|------|------|----|-------------------|-------------|------------------------|---------------------|
| .625 | 1.50 | 2.00 | .50 | .56 | .250 | 4 | #10-24 x .94 LG | 1.125 | 1472340062 | 1481740062 |
| 1.00 | 2.00 | 2.50 | .50 | .88 | .250 | 6 | .250-20 x 1.25 LG | 1.500 | 1472340100 | 1481740100 |
| 1.375 | 2.50 | 3.00 | .63 | 1.00 | .250 | 6 | .312-18 x 1.50 LG | 2.000 | 1472340138 | 1481740138 |
| 1.75 | 3.00 | 4.00 | .63 | 1.25 | .250 | 8 | .312-18 x 1.75 LG | 2.375 | 1472340175 | 1481740175 |
| 2.00 | 3.50 | 4.00 | .75 | 1.63 | .375 | 12 | .375-16 x 2.25 LG | 2.687 | 1472340200 | 1481740200 |
| 2.50 | 4.00 | 4.50 | .75 | 1.88 | .375 | 12 | .375-16 x 2.50 LG | 3.187 | 1472340250 | 1481740250 |
| 3.00 | 5.00 | 5.50 | 1.00 | 2.38 | .375 | 12 | .500-13 x 3.25 LG | 4.000 | 1472340300 | 1481740300 |
| 3.50 | 5.88 | 7.00 | 1.00 | 2.63 | .375 | 12 | .625-11 x 3.50 LG | 4.687 | 1472340350 | 1481740350 |
| 4.00 | 6.38 | 7.00 | 1.00 | 2.63 | .375 | 12 | .625-11 x 3.50 LG | 5.187 | 1472340400 | 1481740400 |
| 5.00 | 7.38 | 8.00 | 1.00 | 3.13 | .375 | 12 | .625-11 x 4.00 LG | 6.187 | 1472340500 | 1481740500 |
| 5.50 | 8.25 | 9.00 | 1.25 | 3.88 | .375 | 12 | .750-10 x 5.00 LG | 6.875 | 1472340550 | 1481740550 |

Note: Screws are not included with split coupler or weld plate.

Miller AV Series Heavy-Duty Air Cylinders

Linear Alignment
Couplers

Linear Alignment Couplers are available in 13 standard thread sizes...

Cost Saving Features and Benefits Include...

- Maximum reliability for trouble-free operation, long life and lower operating costs
- Increased cylinder life by reducing wear on piston and rod bearings
- Simplifying cylinder installation and reducing assembly costs
- Increase rod bearing and rod seal life for lower maintenance costs

Alignment Coupler

See Table 1 for Part Numbers and Dimensions

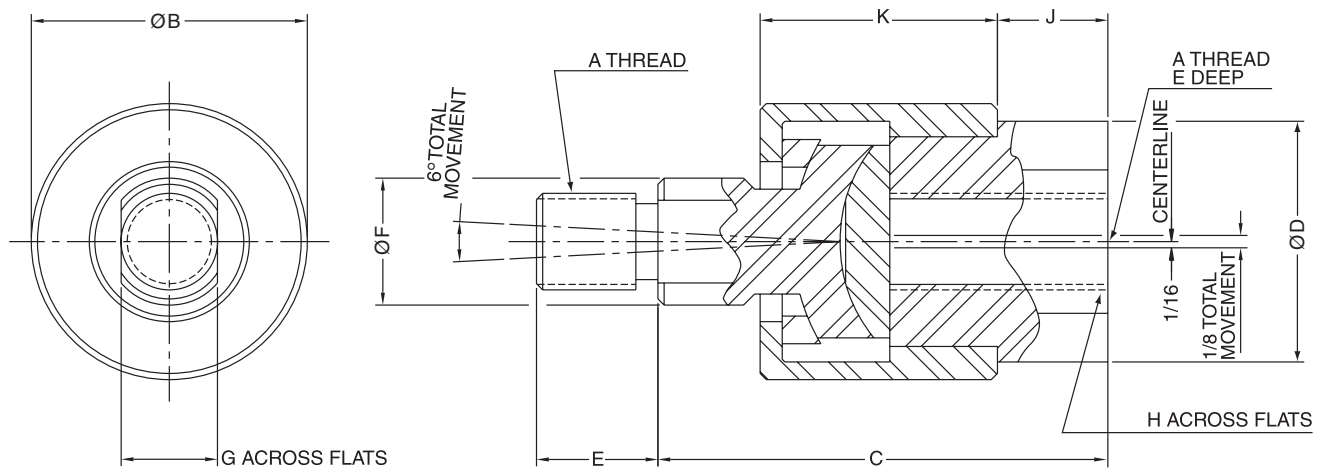

Table 1 — Part Numbers and Dimensions

| Part No. | A | B Ø | C | D Ø | E | F Ø | G | H | J | K | Max. Pull Load (lbs.) | Approx. Weight (lbs.) |
|------------|----------|-------|--------|-------|-------|--------|---------|---------|-------|---------|-----------------------|-----------------------|
| 1347570031 | 5/16-24 | 1 1/8 | 1 3/4 | 15/16 | 1/2 | 1/2 | 3/8 | 3/4 | 3/8 | 15/16 | 1200 | .35 |
| 1347570038 | 3/8-24 | 1 1/8 | 1 3/4 | 15/16 | 1/2 | 1/2 | 3/8 | 3/4 | 3/8 | 15/16 | 2425 | .35 |
| 1347570044 | 7/16-20 | 1 3/8 | 2 | 1 1/8 | 3/4 | 5/8 | 1/2 | 7/8 | 3/8 | 1 3/32 | 3250 | .55 |
| 1347570050 | 1/2-20 | 1 3/8 | 2 | 1 1/8 | 3/4 | 5/8 | 1/2 | 7/8 | 3/8 | 1 3/32 | 4450 | .55 |
| 1347570063 | 5/8-18 | 1 3/8 | 2 | 1 1/8 | 3/4 | 5/8 | 1/2 | 7/8 | 3/8 | 1 3/32 | 6800 | .55 |
| 1347570075 | 3/4-16 | 2 | 2 5/16 | 1 5/8 | 1 1/8 | 15/16 | 3/4 | 1 5/16 | 7/16 | 1 9/32 | 9050 | 1.4 |
| 1347570088 | 7/8-14 | 2 | 2 5/16 | 1 5/8 | 1 1/8 | 15/16 | 3/4 | 1 5/16 | 7/16 | 1 9/32 | 14450 | 1.4 |
| 1347570100 | 1-14 | 3 1/8 | 3 | 2 3/8 | 1 5/8 | 1 7/16 | 1 1/4 | 1 7/8 | 3/4 | 1 25/32 | 19425 | 4.8 |
| 1347570125 | 1 1/4-12 | 3 1/8 | 3 | 2 3/8 | 1 5/8 | 1 7/16 | 1 1/4 | 1 7/8 | 3/4 | 1 25/32 | 30500 | 4.8 |
| 1337390125 | 1 1/4-12 | 3 1/2 | 4 | 2 | 2 | 1 1/2 | 1 1/4 | 1 11/16 | 3/4 | 2 1/2 | 30500 | 6.9 |
| 1337390150 | 1 1/2-12 | 4 | 4 3/8 | 2 1/4 | 2 1/4 | 1 3/4 | 1 1/2 | 1 15/16 | 7/8 | 2 3/4 | 45750 | 9.8 |
| 1337390175 | 1 3/4-12 | 4 | 4 3/8 | 2 1/4 | 2 1/4 | 1 3/4 | 1 1/2 | 1 15/16 | 7/8 | 2 3/4 | 58350 | 9.8 |
| 1337390188 | 1 7/8-12 | 5 | 5 5/8 | 3 | 3 | 2 1/4 | 1 15/16 | 2 5/8 | 1 3/8 | 3 3/8 | 67550 | 19.8 |

How to Order Linear Alignment Couplers — When ordering a cylinder with a threaded male rod end, specify the coupler of equal thread size by part number as listed in Table 1, i.e.; Piston Rod “KK” dimension is 3/4" - 16", specify coupler part number 1347570075.

Miller AV Series Heavy-Duty Air Cylinders

Push and Pull Forces

Theoretical Push and Pull Forces Push Force and Displacement

| Cyl. Bore Size (Inches) | Piston Area (Sq. In.) | Cylinder Push Stroke Force In Pounds At Various Pressures | | | | | | Cu. Ft. Free Air At 80 Lbs. Pressure, Required To Move Max. Load 1 Inch |
|-------------------------|-----------------------|---|------|-------|-------|-------|-------|---|
| | | 25 | 50 | 65 | 80 | 100 | 250 | |
| 1 | .785 | 20 | 39 | 51 | 65 | 79 | 196 | .00293 |
| 1½ | 1.767 | 44 | 88 | 115 | 142 | 177 | 443 | .00659 |
| 2 | 3.14 | 79 | 157 | 204 | 251 | 314 | 785 | .01171 |
| 2½ | 4.91 | 123 | 245 | 319 | 393 | 491 | 1228 | .01830 |
| 3¼ | 8.30 | 208 | 415 | 540 | 664 | 830 | 2075 | .03093 |
| 4 | 12.57 | 314 | 628 | 817 | 1006 | 1257 | 3143 | .04685 |
| 5 | 19.64 | 491 | 982 | 1277 | 1571 | 1964 | 4910 | .07320 |
| 6 | 28.27 | 707 | 1414 | 1838 | 2262 | 2827 | 7068 | .10541 |
| 7 | 38.49 | 962 | 1924 | 2502 | 3079 | 3849 | 9623 | .14347 |
| 8 | 50.27 | 1257 | 2513 | 3268 | 4022 | 5027 | 12568 | .18740 |
| 10 | 78.54 | 1964 | 3927 | 5105 | 6283 | 7854 | 19635 | .29280 |
| 12 | 113.10 | 2828 | 5655 | 7352 | 9048 | 11310 | 28275 | .42164 |
| 14 | 153.94 | 3849 | 7697 | 10006 | 12315 | 15394 | 38485 | .57389 |

Deductions for Pull Force and Displacement

| Piston Rod Ø (Inches) | Piston Area (Sq. In.) | Piston Rod Diameter Force In Pounds At Various Pressures | | | | | | Cu. Ft. Free Air At 80 Lbs. Pressure, Required To Move Max. Load 1 Inch |
|--|-----------------------|--|------|------|------|------|------|---|
| | | 25 | 50 | 65 | 80 | 100 | 250 | |
| To determine Cylinder Pull Force or Displacement, deduct the following Force or Displacement corresponding to Rod Size, from selected Push Stroke Force or Displacement corresponding to Bore Size in table above. | | | | | | | | |
| ½ | .196 | 5 | 10 | 13 | 16 | 20 | 49 | .00073 |
| ⅝ | .307 | 8 | 15 | 20 | 25 | 31 | 77 | .00114 |
| 1 | .785 | 20 | 39 | 51 | 65 | 79 | 196 | .00293 |
| 1⅜ | 1.49 | 37 | 75 | 97 | 119 | 149 | 373 | .00554 |
| 1¾ | 2.41 | 60 | 121 | 157 | 193 | 241 | 603 | .00897 |
| 2 | 3.14 | 79 | 157 | 204 | 251 | 314 | 785 | .01171 |
| 2½ | 4.91 | 123 | 245 | 319 | 393 | 491 | 1228 | .01830 |
| 3 | 7.07 | 177 | 354 | 460 | 566 | 707 | 1767 | .02635 |
| 3½ | 9.62 | 241 | 481 | 625 | 770 | 962 | 2405 | .03587 |
| 4 | 12.57 | 314 | 628 | 817 | 1006 | 1257 | 3143 | .04685 |
| 4½ | 15.90 | 398 | 795 | 1033 | 1272 | 1590 | 3975 | .05929 |
| 5 | 19.64 | 491 | 982 | 1277 | 1571 | 1964 | 4910 | .07320 |
| 5½ | 23.76 | 594 | 1188 | 1544 | 1901 | 2376 | 5940 | .08857 |

General Formula

The cylinder output forces are derived from the formula:

$$F = P \times A$$

Where F = Force in pounds.
P = Pressure at the cylinder in pounds per square inch, gauge.
A = Effective area of cylinder piston in square inches.

Free Air refers to normal atmospheric conditions of the air at sea level (14.7 psi). Use above cu. ft. free air required data to

compute CFM required from a compressor at 80 psi. cu. ft. of free air required at other pressures can be calculated using formula below.

$$V^1 = \frac{(P^2 + 14.7) V^2}{14.7}$$

Where V¹ = Free air consumption per inch of stroke (cubic feet).

V² = Cubic feet displaced per inch of stroke.

P² = Gauge pressure required to move maximum load.

Miller AV Series Heavy-Duty Air Cylinders

Operating Fluids and Temperature Range

AV Series cylinders are equipped with seals for use with lubricated air. In some cases special seals are required.

Class 1 Seals

Class 1 seals are the standard seals provided in a cylinder assembly. They are intended for use with fluids such as: air, nitrogen, mineral base hydraulic oil or MIL-H-5606 within the temperature range of -10°F (-23°C) to +165°F (+74°C). The individual seals may be nitrile (Buna-N), enhanced polyurethane, polymyte, PTFE or filled PTFE.

Class 4 Seals — Nitrile Seals

Class 4 seals are intended for low temperature service with the same type of fluids as used with Class 1 seals within the temperature range of -50°F (-46°C) to +150°F (+66°C). Class 4 seals are nitrile seals. Lipseals will have leather, polymyte or PTFE back-up washers when required. O-rings will have nitrile back-up washers when required.

Note: Certain fluids may react adversely with Class 4 seals compared to Class 1 seals.

Class 5 Seals — Fluorocarbon Seals

Class 5 seals are intended for elevated temperature service. Note: In addition, Class 5 seals can be used with fluids listed below under Class 1 service. Class 5 seals can operate with a temperature range of -10°F (-23°C) to +250°F (+121°C). Fluorocarbon seals may be operated to +400°F (+204°C) with limited service life. For temperatures above +250°F (+121°C) the cylinder must be manufactured with non-studded piston rod thread and a pinned piston to rod connection. Class 5 seals are fluorocarbon seals. Lipseals will have PTFE back-up washers when required. O-rings will have fluorocarbon back-up when required.

Lipseal Pistons

Under most conditions lipseals provide the best all around service for pneumatic applications. Lipseals with a back-up washers are often used for hydraulic applications when virtually zero static leakage is required. Lipseals will function properly in these applications when used in conjunction with moderate hydraulic pressures.

Warning!

The piston rod stud and the piston rod to piston threaded connections are secured with an anaerobic adhesive which is temperature sensitive. Cylinders specified with fluorocarbon seals are assembled with anaerobic adhesive having a maximum temperature rating of +250°F (+121°C). Cylinders specified with all other seal compounds are assembled with anaerobic adhesive have a maximum operating temperature rating +165°F (+74°C). These temperature limitations are necessary to prevent the possible loosening of the threaded connections. Cylinders originally manufactured with Class 1 seals (Nitrile) that will be exposed to ambient temperatures above +165°F (+74°C) must be modified for higher temperature service. Contact the factory immediately and arrange for the piston to rod and the stud to piston rod connections to be properly reassembled to withstand the higher temperature service.

| Class No. | Typical Fluids | Temperature Range |
|--|--|--|
| 1 Standard Nitrile Polyurethane | Air, Nitrogen Hydraulic Oil, Mil-H-5606 Oil | -10°F (-23°C) to +165°F (+74°C) |
| 4 Special (Nitrile) (At extra cost) | Low Temperature Air | -50°F (-46°C) to +150°F (+66°C) |
| 5 Optional (At extra cost) (Fluorocarbon Seals) | High Temperature | See above paragraph on Fluorocarbon seals for recommended temperature range. |

Miller AV Series Heavy-Duty Air Cylinders

NOTES

Miller AV Series Heavy-Duty Air Cylinders

Ports

Ports

Miller AV Series pneumatic cylinders are supplied with NPTF pipe thread ports. If specified on your order, extra ports can be provided on the sides of heads or caps that are not occupied by mountings or cushion valve.

Standard port location is position 1 as shown on line drawings in product catalog and Figure 1 below. Cushion adjustment needle and check valves are at position 2 (or 3), depending on mounting style. Heads or caps which do not have an integral mounting can be rotated and assembled with ports at 90° or 180° from standard position. Mounting styles on which head or cap can be rotated at no extra charge are shown in Table A below. To order, specify by position number. In such assemblies the cushion adjustment needle and check valve rotate accordingly since their relationship with port position does not change.

Figure 1

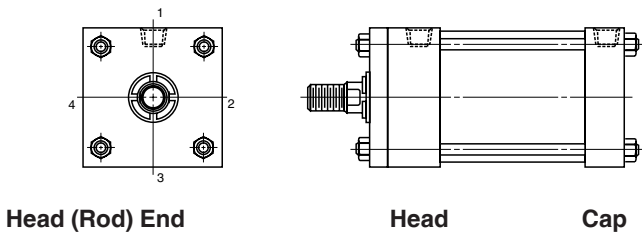

Table A

| Model | Port Position Available | |
|--|-------------------------|--------------|
| | Head End | Cap End |
| 51, 52, 53, 61, 62, 63, 64, 65, 66, 89 | 1, 2, 3 or 4 | 1, 2, 3 or 4 |
| 82, 84 | 1,2, 3 or 4 | 1 or 3 |
| 81 | 1 or 3 | 1, 2, 3 or 4 |
| 72, 74 | 1 | 1 |

Ports can be supplied at positions other than those shown in Table A at an extra charge. To order, specify port position as shown in Figure 1.

International Ports

Other port configurations to meet international requirements are available at extra cost. Miller AV Series cylinders can be supplied, on request, with British standard taper port (BSPT). Such port has a taper of 1 in 16 measured on the diameter ($1/16$ " per inch). The thread form is Whitworth System, and size and number of threads per inch are as follows:

Table B

British Standard Pipe Threads

| Nominal Pipe Size | No. Threads Per Inch | Pipe O.D. |
|-------------------|----------------------|-----------|
| $1/8$ | 28 | .383 |
| $1/4$ | 19 | .518 |
| $3/8$ | 19 | .656 |
| $1/2$ | 14 | .825 |
| $3/4$ | 14 | 1.041 |
| 1 | 11 | 1.309 |
| $1 1/4$ | 11 | 1.650 |
| $1 1/2$ | 11 | 1.882 |
| 2 | 11 | 2.347 |

British standard parallel internal threads are designated as BSPP and have the same thread form and number of threads per inch as the BSPT type and can be supplied, on request, at extra cost. Unless otherwise specified, the BSPP or BSPT port size supplied will be the same nominal pipe size as the NPTF port for a given bore size cylinder.

Metric ports can also be supplied to order at extra cost. Consult factory.

Oversize Ports

Oversize NPTF ports can be provided, at an extra charge. For ports one size larger than standard, welded port bosses which protrude from the side of the head or cap are supplied. For dimensions, see drawing below and table.

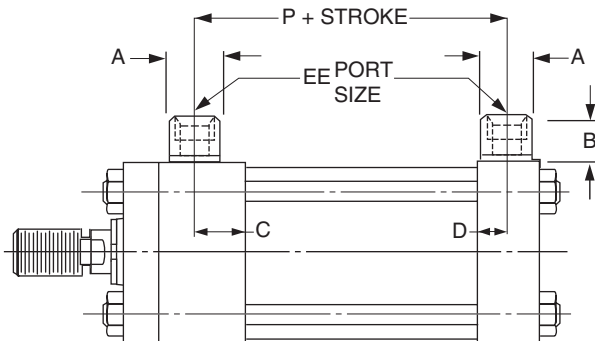

Oversize NPTF Port Boss Dimensions

| Bore | EE (NPTF) | A Ø | B | C | D | P |
|---------|-----------|---------|----------|----------|---------|-----------|
| 1 | $3/8$ | $7/8$ | $3/4$ | $9/16$ | $1/2$ | $2 1/16$ |
| $1 1/2$ | $1/2$ | $1 1/8$ | $15/16$ | $9/16$ | $1/2$ | $2 3/16$ |
| 2 | $1/2$ | $1 1/8$ | $15/16$ | $9/16$ | $1/2$ | $2 3/16$ |
| $2 1/2$ | $1/2$ | $1 1/8$ | $15/16$ | $9/16$ | $1/2$ | $2 5/16$ |
| $3 1/4$ | $3/4$ | $1 3/8$ | 1 | $1 1/16$ | $5/8$ | $2 9/16$ |
| 4 | $3/4$ | $1 3/8$ | 1 | $1 1/16$ | $5/8$ | $2 9/16$ |
| 5 | $3/4$ | $1 3/8$ | 1 | $1 1/16$ | $5/8$ | $2 13/16$ |
| 6 | 1 | $1 3/4$ | $1 3/16$ | $15/16$ | $3/4$ | $3 3/16$ |
| 7-8 | 1 | $1 3/4$ | $1 3/16$ | $15/16$ | $3/4$ | $3 5/16$ |
| 10 | $1 1/4$ | $2 1/4$ | $1 5/16$ | $1 1/8$ | 1 | $4 1/4$ |
| 12 | $1 1/4$ | $2 1/4$ | $1 5/16$ | $1 1/8$ | 1 | $4 3/4$ |
| 14 | $1 1/2$ | $2 1/2$ | $1 9/16$ | $1 1/4$ | $1 1/8$ | $5 1/2$ |

Miller AV Series Heavy-Duty Air Cylinders

Stroke Tolerance
Cylinder Weights

Stroke Tolerance

Stroke length tolerances are required due to buildup of tolerances of piston, head, cap and cylinder body. Standard production stroke tolerances run $+1/32"$ to $-1/64"$ up to 20" stroke, $+1/32"$ to $-.20"$ for 21" to 60" and $+1/32"$ to $-1/32"$ for greater than 60" stroke. For closer tolerances on stroke length, it is necessary to specify the required tolerance plus the operating pressure

and temperature at which the cylinder will operate. Stroke tolerances smaller than $.015"$ are not generally practical due to elasticity of cylinders. If machine design requires such close tolerances, use of a stroke adjuster may achieve the desired result.

Cylinder Weights

The weights shown in Table A are for Miller Series AV and AVN cylinders with various piston rod diameters. To determine the net weight of a cylinder, first select the proper basic weight for zero stroke, then calculate the weight of the cylinder stroke and add the result to the basic weight. For extra rod extension,

use piston rod weights per inch shown in Table B. Weights of cylinders with intermediate rods may be estimated from table below by taking the difference between the piston rod weights per inch and adding it to the standard rod diameter weight for the cylinder bore size involved.

Table A Cylinder Weights, in pounds, for AV & AVN Series cylinders

| Bore Size | Rod Ø | Single Rod Cylinders Basic Wt. Zero Stroke | | Add Per Inch of Stroke | Double Rod Cylinders Basic Wt. Zero Stroke | | Add Per Inch of Stroke |
|-----------|--------|---|--------------------------------|------------------------|---|--------------------|------------------------|
| | | 51, 52, 53, 61, 62, 63, 64, 74 | 65, 66, 72, 81, 82, 84, 89, 94 | | D51, D53, D61, D74 | D61, D72, D81, D89 | |
| 1" | 1/2" | 2.5 | 2.9 | .20 | 4.7 | 5.5 | .40 |
| | 5/8" | 2.6 | 3.0 | .23 | 4.9 | 5.7 | .46 |
| 1 1/2" | 5/8" | 3.7 | 4.3 | .3 | 4.2 | 4.8 | .6 |
| | 1" | 4.5 | 5.1 | .4 | 5.8 | 6.7 | .8 |
| 2" | 5/8" | 6.5 | 6.9 | .5 | 8.2 | 8.6 | 1.0 |
| | 1" | 7.0 | 7.5 | .63 | 9.0 | 9.5 | 1.3 |
| | 1 3/8" | 8.5 | 8.9 | .8 | 11.2 | 11.6 | 1.6 |
| 2 1/2" | 5/8" | 9.0 | 9.7 | .6 | 11.4 | 12.1 | 1.2 |
| | 1" | 9.5 | 10.0 | .73 | 12.0 | 12.5 | 1.5 |
| | 1 3/4" | 13.2 | 13.6 | 1.1 | 19.8 | 20.5 | 2.2 |
| 3 1/4" | 1" | 16.5 | 17.5 | .8 | 22.0 | 23.0 | 1.6 |
| | 1 3/8" | 17.0 | 18.0 | 1.0 | 22.5 | 23.5 | 2.0 |
| | 2" | 27.0 | 28.0 | 1.4 | 43.0 | 44.0 | 2.8 |
| 4" | 1" | 26.0 | 31.0 | 1.0 | 33.0 | 38.0 | 2.0 |
| | 1 3/8" | 26.5 | 31.5 | 1.2 | 33.5 | 38.5 | 2.5 |
| | 2 1/2" | 36.0 | 42.0 | 2.0 | 53.0 | 58.0 | 4.0 |
| 5" | 1" | 39.0 | 46.0 | 1.1 | 48.0 | 55.0 | 2.2 |
| | 1 3/8" | 39.5 | 46.5 | 1.3 | 48.5 | 55.5 | 2.6 |
| | 3 1/2" | 63.0 | 66.0 | 3.6 | 96.0 | 103.0 | 7.2 |
| 6" | 1 3/8" | 68.0 | 77.0 | 1.5 | 80.0 | 89.0 | 3.0 |
| | 4" | 100.0 | 102.0 | 4.5 | 144.0 | 153.0 | 9.0 |
| 7" | 1 3/8" | 80.0 | 85.0 | 2.0 | 92.0 | 97.0 | 4.0 |
| | 2" | 82.0 | 87.0 | 3.5 | 96.0 | 101.0 | 7.0 |
| 8" | 1 3/8" | 94.0 | 99.0 | 2.0 | 108.0 | 113.0 | 4.0 |
| | 5 1/2" | 168.0 | 172.0 | 8.0 | 256.0 | 261.0 | 16.0 |
| 10" | 1 3/4" | 182.0 | 188.0 | 2.5 | 178.0 | 184.0 | 5.0 |
| | 5 1/2" | 258.0 | 264.0 | 8.5 | 330.0 | 335.0 | 17.0 |
| 12" | 2" | 274.0 | 282.0 | 3.5 | 270.0 | 280.0 | 7.0 |
| | 5 1/2" | 350.0 | 358.0 | 9.5 | 420.0 | 430.0 | 19.0 |
| 14" | 2 1/2" | 435.0 | 448.0 | 4.5 | 440.0 | 655.0 | 9.0 |
| | 5 1/2" | 510.0 | 519.0 | 10.0 | 490.0 | 705.0 | 20.0 |

Table B

| Rod Ø | Piston Rod Wt. Per Inch | Rod Ø | Piston Rod Wt. Per Inch | Rod Ø | Piston Rod Wt. Per Inch |
|--------|-------------------------|--------|-------------------------|--------|-------------------------|
| 5/8" | .09 | 2" | .89 | 4" | 3.56 |
| 1" | .22 | 2 1/2" | 1.40 | 4 1/2" | 4.51 |
| 1 3/8" | .42 | 3" | 2.00 | 5" | 5.56 |
| 1 3/4" | .68 | 3 1/2" | 2.72 | 5 1/2" | 6.72 |

Miller AV Series Heavy-Duty Air Cylinders

Stop Tubing
Mounting Classes

Stop Tubing

Stop tube is recommended to lengthen the distance between the bushing and piston to reduce bearing loads when the cylinder is fully extended. This is especially true of horizontally mounted and long stroke cylinders. Long stroke cylinders achieve additional stability through the use of a stop tube.

When specifying cylinders with long stroke and stop tube, be sure to call out the net stroke and the length of the stop tube. Machine design can be continued without delay by laying in a cylinder equivalent in length to the NET STROKE PLUS STOP TUBE LENGTH, which is referred to as GROSS STROKE.

Drawing A

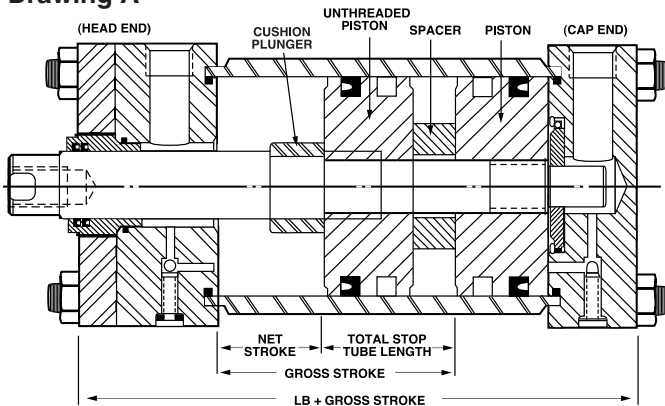

Double piston design is supplied on air cylinders with cushion head end or both ends.

Drawing B

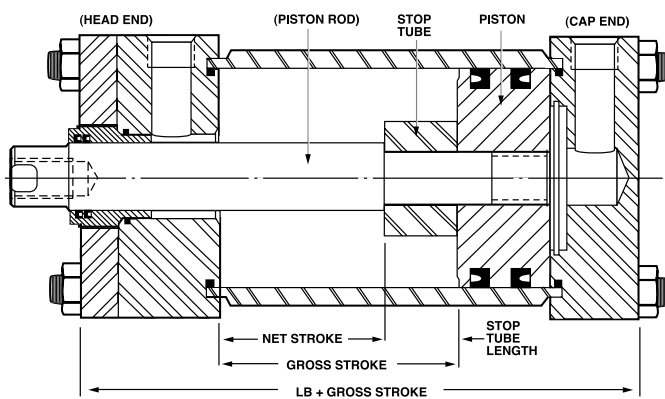

This design is supplied on all non-cushion cylinders.

Mounting Classes

Standard mountings for fluid power cylinders fall into three basic groups. The groups can be summarized as follows:

Group 1 Straight Line Force Transfer with fixed mounts which absorb force on cylinder centerline.

Group 2 Pivot Force Transfer. Pivot mountings permit a cylinder to change its alignment in one plane.

Group 3 Straight Line Force Transfer with fixed mounts which do not absorb force on cylinder centerline.

Because a cylinder's mounting directly affects the maximum pressure at which the cylinder can be used, the chart below should be helpful in selection of the proper mounting combination for your application. Stroke length, piston rod connection to load, extra piston rod length over standard, etc., should be considered for thrust loads. Alloy steel mounting bolts are recommended for all mounting styles, and thrust keys are recommended for Group 3.

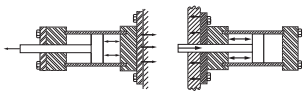
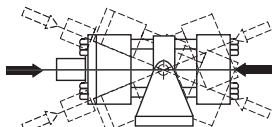
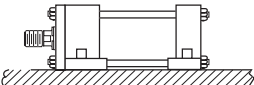
| | |
|--|---|
| Group 1 FIXED MOUNTS which absorb force on cylinder centerline. | |
| <p>Heavy-Duty Service For Thrust Loads For Tension Loads</p> |  <p>Model 52 Model 53</p> |
| <p>Medium-Duty Service For Thrust Loads For Tension Loads</p> | <p>Models 62, 66 Models 61, 65</p> |
| <p>Light-Duty Service For Thrust Loads For Tension Loads</p> | <p>Model 62 Model 61</p> |
| Group 2 PIVOT MOUNTS which absorb force on cylinder centerline. | |
| <p>Heavy-Duty Service For Thrust Loads For Tension Loads</p> |  <p>Models 81, 89 Models 81, 82, 84, 89</p> |
| <p>Medium-Duty Service For Thrust Loads For Tension Loads</p> | <p>Model 84 Model 84</p> |
| Group 3 FIXED MOUNTS which do not absorb force on the centerline. | |
| <p>Heavy-Duty Service For Thrust Loads For Tension Loads</p> |  <p>Model 72 Model 72</p> |
| <p>Medium-Duty Service For Thrust Loads For Tension Loads</p> | <p>Model 74 Model 74</p> |

Miller AV Series Heavy-Duty Air Cylinders

Piston Rod — Stroke Selection Chart

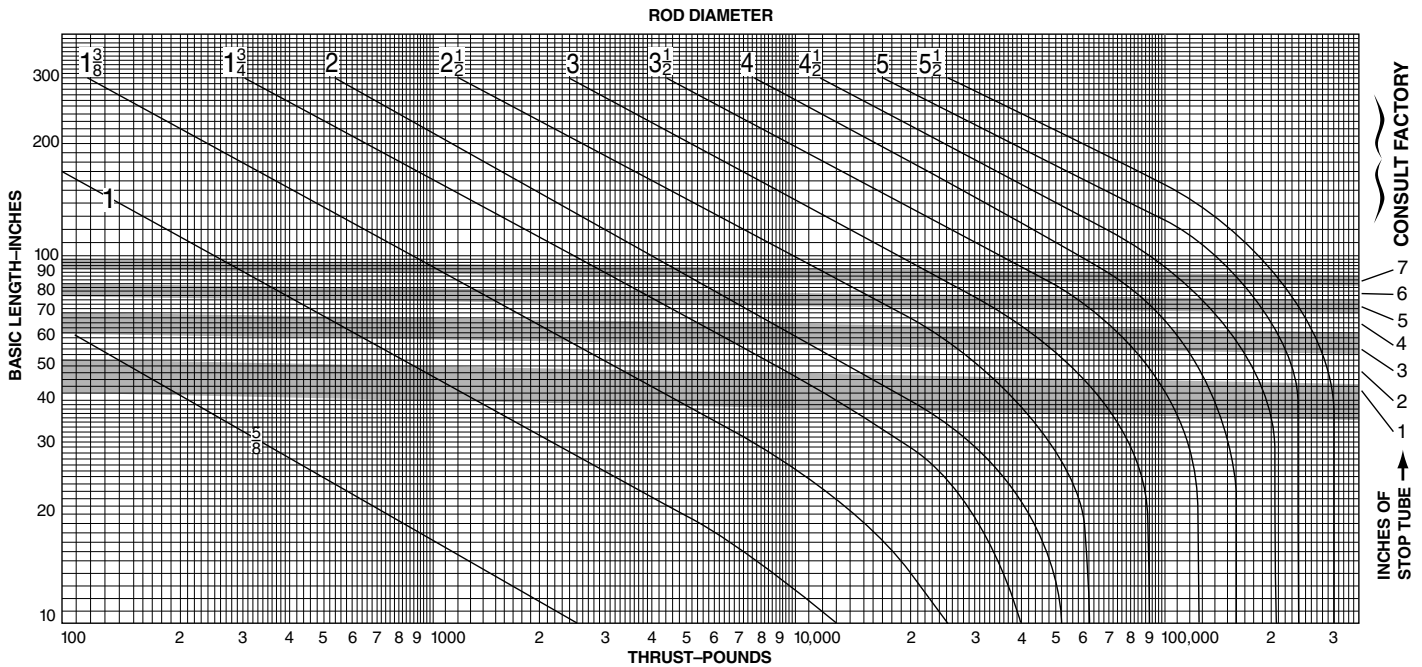

How to Use the Chart

The selection of a piston rod for thrust (push) conditions requires the following steps:





- Determine the type of cylinder mounting style and rod end connection to be used. Then consult the chart below and find the "stroke factor" that corresponds to the conditions used.
- Using this stroke factor, determine the "basic length" from the equation:

$$\text{Basic Length} = \frac{\text{Actual Stroke}}{\text{Stroke Factor}}$$

The graph is prepared for standard rod extensions beyond the face of the gland retainers. For rod extensions greater than standard, add the increase to the stroke in arriving at the "basic length."

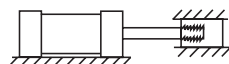
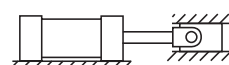
- Find the load imposed for the thrust application by multiplying the full bore area of the cylinder by the system pressure.
- Enter the graph along the values of "basic length" and "thrust" as found above and note the point of intersection:

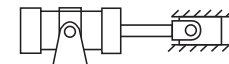
- The correct piston rod size is read from the diagonally curved line labeled "Rod Diameter" next above the point of intersection.
- The required length of stop tube is read from the right of the graph by following the shaded band in which the point of intersection lies.
- If required length of stop tube is in the region labeled "consult factory," submit the following information for an individual analysis:
 - Cylinder mounting style.
 - Rod end connection and method of guiding load.
 - Bore, required stroke, length of rod extension (Dim. "LA") if greater than standard, and series of cylinder used.
 - Mounting position of cylinder. (Note: If at an angle or vertical, specify direction of piston rod.)
 - Operating pressure of cylinder if limited to less than standard pressure for cylinder selected.

| Recommended Mounting Styles for Maximum Stroke and Thrust Loads | Rod End Connection | Case | Stroke Factor |
|--|----------------------------------|---|---------------|
| Groups 1 or 3 Long stroke cylinders for thrust loads should be mounted using a heavy-duty mounting style at one end, firmly fixed and aligned to take the principal force. Additional mounting should be specified at the opposite end, which should be used for alignment and support. An intermediate support may also be desirable for long stroke cylinders mounted horizontally. Machine mounting pads can be adjustable for support mountings to achieve proper alignment. | Fixed and Rigidly Guided | I  | .50 |
| | Pivoted and Rigidly Guided | II  | .70 |
| | Supported but not Rigidly Guided | III  | 2.00 |
| Group 2 Model 81 — Trunnion on Head | Pivoted and Rigidly Guided | IV  | 1.00 |
| Model 89 — Intermediate Trunnion | Pivoted and Rigidly Guided | V  | 1.50 |
| Model 82 — Trunnion on Cap or Model 84 — Clevis on Cap | Pivoted and Rigidly Guided | VI  | 2.00 |

Miller AV Series Heavy-Duty Air Cylinders

Deceleration Force and
Air Requirements

Cushion ratings for **air cylinders only** are described in Table B-7 and Graph B-3. To determine whether a cylinder will adequately stop a load without damage to the cylinder, the weight of the load (including the weight of the piston and the piston rod from Table B-6) and the maximum speed of the piston rod must first be determined. Once these two factors are known, the Kinetic Energy Graph may be used. Enter the graph at its base for the value of weight determined, and project vertically to the required speed value. The point of intersection of these two lines will be the cushion rating number required for the application.

To determine the total load to be moved, the weight of the piston and rod must be included.

Total Weight = Weight of the piston and non-stroke rod length (Column 1) + weight of the rod per inch of stroke x the inches of stroke (Column 2) + the load to be moved.

Table B-6 — Weight

| Bore Ø | Column 1 Basic Wgt. (Lbs.) for Piston & Non-Stroke Rod | Rod Ø | Column 2 Basic Wgt. (Lbs.) for 1" Stroke |
|--------|--|-------|--|
| 1½ | 1.5 | 5/8 | .087 |
| 2 | 3.0 | 1 | .223 |
| 2½ | 5.4 | 1¾ | .421 |
| 3¼ | 8.3 | 1¾ | .682 |
| 4 | 14.2 | 2 | .89 |
| 5 | 29 | 2½ | 1.39 |
| 6 | 41 | 3 | 2.0 |
| 8 | 89 | 3½ | 2.73 |
| 10 | 115 | 4 | 3.56 |
| 12 | 161 | 5 | 5.56 |
| 14 | 207 | 5½ | 6.73 |

Example: A 3-1/4" bore cylinder, having a 1" diameter rod and 25" stroke; load to be moved is 85 lbs. Total load to be moved is then 8.3 lbs. + .223 lbs./in. x 25 in. + 85 lbs. or a total of 99 lbs.

Graph B3 — Kinetic Energy — Air Cylinders

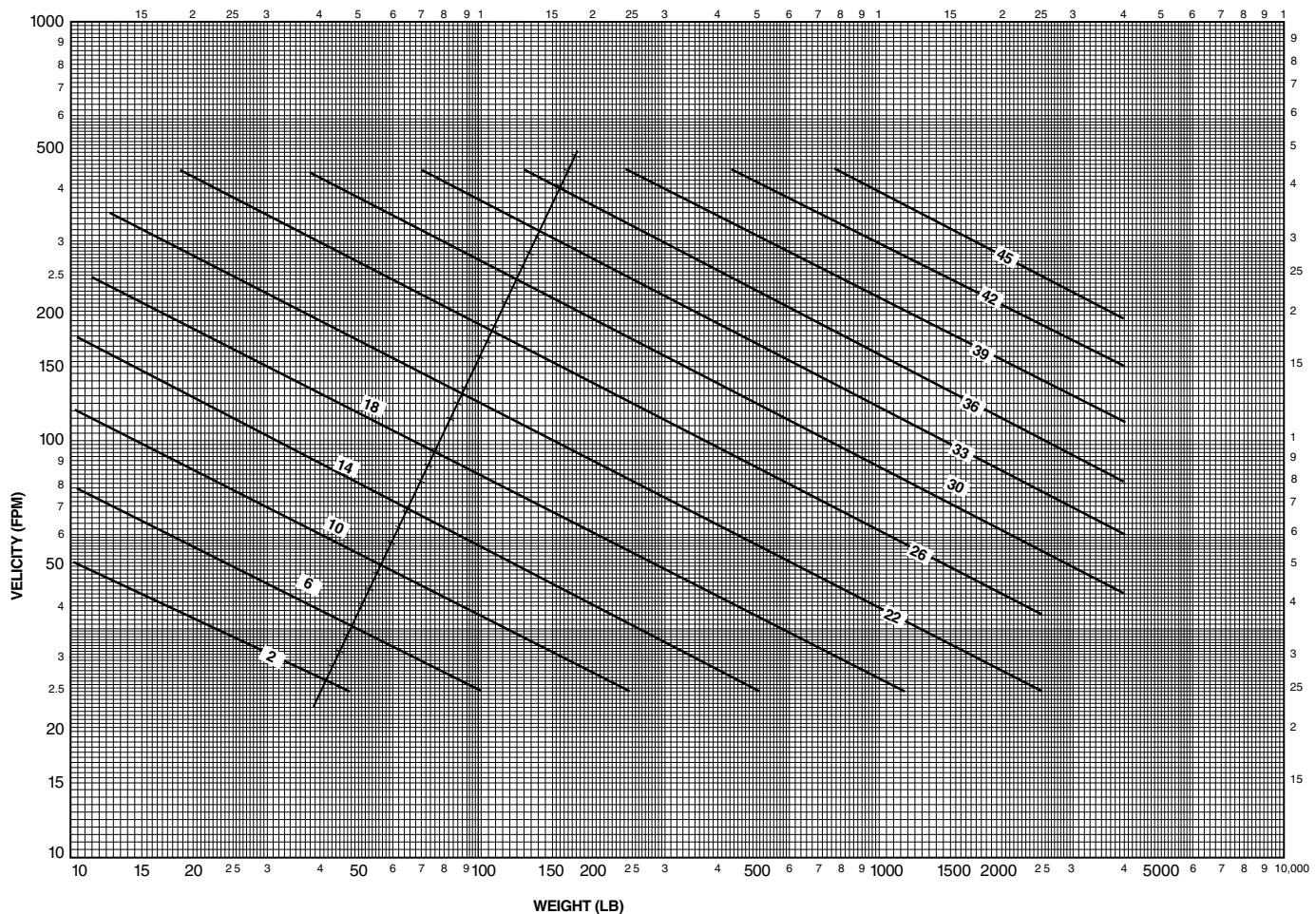

Miller AV Series Heavy-Duty Air Cylinders

Air Cylinder Cushion Ratings
Air Requirements

Now refer to Table B-7 and find the cushion ratings, using bore size and rod diameter of the cylinder selected. If a simple circuit is used, with no meter out or speed control, use the "no back pressure, Column A" values. If a meter out or speed control is to be used, use the back pressure column values, If the cushion rating found in Table B-7 (below) is **greater** than the number determined in Graph

the cylinder will stop the load adequately. If the cushion rating in Table B-7 is **smaller** than the number found in Graph B-3, then a larger bore cylinder should be used. In those applications where back pressures exist in the exhaust lines, it is possible to exceed the cushion ratings shown in Table B-7. In these cases, consult the factory and advise the amount of back pressure.

Table B-7 — Air Cylinder Cushion Ratings

| Bore Ø | Rod Ø | Rating with No Back Pressure | Rating with Back Pressure |
|--------|---------|------------------------------|---------------------------|
| 1½ | Cap End | 12 | 17 |
| | 5/8 | 8 | 14 |
| | 1 | 3 | 8 |
| 2 | Cap End | 14 | 20 |
| | 5/8 | 12 | 18 |
| | 1 | 9 | 15 |
| | 1 3/8 | 6 | 11 |
| 2½ | Cap End | 17 | 23 |
| | 5/8 | 14 | 20 |
| | 1 | 14 | 19 |
| | 1 3/8 | 12 | 18 |
| | 1 3/4 | 8 | 13 |
| 3¼ | Cap End | 21 | 26 |
| | 5/8 | 18 | 24 |
| | 1 3/8 | 17 | 23 |
| | 1 3/4 | 16 | 22 |
| | 2 | 13 | 19 |
| 4 | Cap End | 23 | 28 |
| | 1 | 20 | 27 |
| | 1 3/8 | 20 | 26 |
| | 1 3/4 | 19 | 25 |
| | 2 | 17 | 23 |
| | 2½ | 17 | 22 |
| 5 | Cap End | 26 | 31 |
| | 1 | 23 | 28 |
| | 1 3/8 | 23 | 28 |
| | 1 3/4 | 22 | 28 |
| | 2 | 20 | 26 |
| | 2½ | 19 | 25 |
| | 3 | 18 | 24 |
| 6 | 3½ | 15 | 20 |
| | Cap End | 26 | 31 |
| | 1 3/8 | 26 | 31 |
| | 1 3/4 | 26 | 31 |
| | 2 | 24 | 29 |
| | 2½ | 24 | 29 |
| | 3 | 22 | 28 |
| | 3½ | 21 | 27 |
| | 4 | 20 | 26 |
| 7 | Cap End | 28 | 33 |
| | 1 3/8 | 28 | 33 |
| | 1 3/4 | 28 | 33 |
| | 2 | 26 | 31 |
| | 2½ | 25 | 30 |

| Bore Ø | Rod Ø | Rating with No Back Pressure | Rating with Back Pressure |
|--------|---------|------------------------------|---------------------------|
| 7 | 3 | 24 | 30 |
| | 3½ | 24 | 30 |
| | 4 | 23 | 29 |
| | 4½ | 22 | 28 |
| | 5 | 21 | 27 |
| 8 | Cap End | 29 | 35 |
| | 1 3/8 | 29 | 35 |
| | 1 3/4 | 29 | 34 |
| | 2 | 27 | 33 |
| | 2½ | 26 | 32 |
| | 3 | 26 | 32 |
| | 3½ | 26 | 32 |
| | 4 | 25 | 31 |
| | 5 | 23 | 29 |
| | 5½ | 22 | 28 |
| 10 | Cap End | 33 | 39 |
| | 1 3/4 | 32 | 38 |
| | 2 | 31 | 37 |
| | 2½ | 31 | 36 |
| | 3 | 30 | 36 |
| | 3½ | 30 | 36 |
| | 4 | 30 | 36 |
| 12 | 5 | 28 | 34 |
| | 5½ | 27 | 33 |
| | Cap End | 35 | 41 |
| | 2 | 33 | 39 |
| | 2½ | 33 | 38 |
| | 3 | 33 | 38 |
| | 3½ | 32 | 38 |
| 14 | 4 | 32 | 38 |
| | 5 | 31 | 36 |
| | 5½ | 31 | 36 |
| | Cap End | 38 | 43 |
| | 2½ | 37 | 42 |
| | 3 | 36 | 42 |
| | 3½ | 36 | 41 |
| 14 | 4 | 36 | 41 |
| | 5 | 35 | 40 |
| | 5½ | 34 | 40 |

Air Requirement per Inch of Cylinder Stroke

The amount of air required to operate a cylinder is determined from the volume of the cylinder and its cycle in strokes per minute. This may be determined by use of the following formulae which apply to a single-acting cylinder.

$$V = \frac{3.1416 L D^2}{4}$$

$$C = \frac{fV}{1728}$$

Where: V = Cylinder volume, cu. in.
L = Cylinder stroke length, in.
D = Internal diameter of cylinder in.
C = Air required, cfm
f = Number of strokes per minute

The air requirements for double-acting cylinder is almost double that of a single-acting cylinder, except for the volume of the piston rod.

Miller AV Series Heavy-Duty Air Cylinders

The air flow requirements of a cylinder in terms of cfm should not be confused with compressor ratings which are given in terms of free air. If compressor capacity is involved in the consideration of cylinder air requirements it will be necessary to convert cfm values to free air values. This relationship varies for different gauge pressures.

Thrust (lbs.) = Operating Pressure x Area of Cylinder Bore

Note: On the “out” stroke the air pressure is working on the entire piston area, but on the “in” stroke the air pressure works on the piston area less the rod area.

Graph B-4 and B-5 offer a simple means to select pneumatic components for dynamic cylinder applications. It is only necessary to know the force required, the desired speed and the pressure which can be maintained at the inlet to the F-R-L “Combo.” The graphs assume average

conditions relative to air line sizes, system layout, friction, etc. At higher speeds, consider appropriate cushioning of cylinders.

The general procedure to follow when using these graphs is:

1. Select the appropriate graph depending upon the pressure which can be maintained to the system — Graph B-4 for 100 psig and Graph B-5 for 80 psig.
2. Determine appropriate cylinder bore. Values underneath the diagonal cylinder bore lines indicate the maximum recommended dynamic thrust developed while the cylinder is in motion. The data in the table at the bottom of each graph indicates available static force for applications

Graph B-4 — This graph is determined by having 100 psig available under flowing conditions.

THIS GRAPH IS DETERMINED BY HAVING
100 PSIG AVAILABLE UNDER FLOWING CONDITIONS.

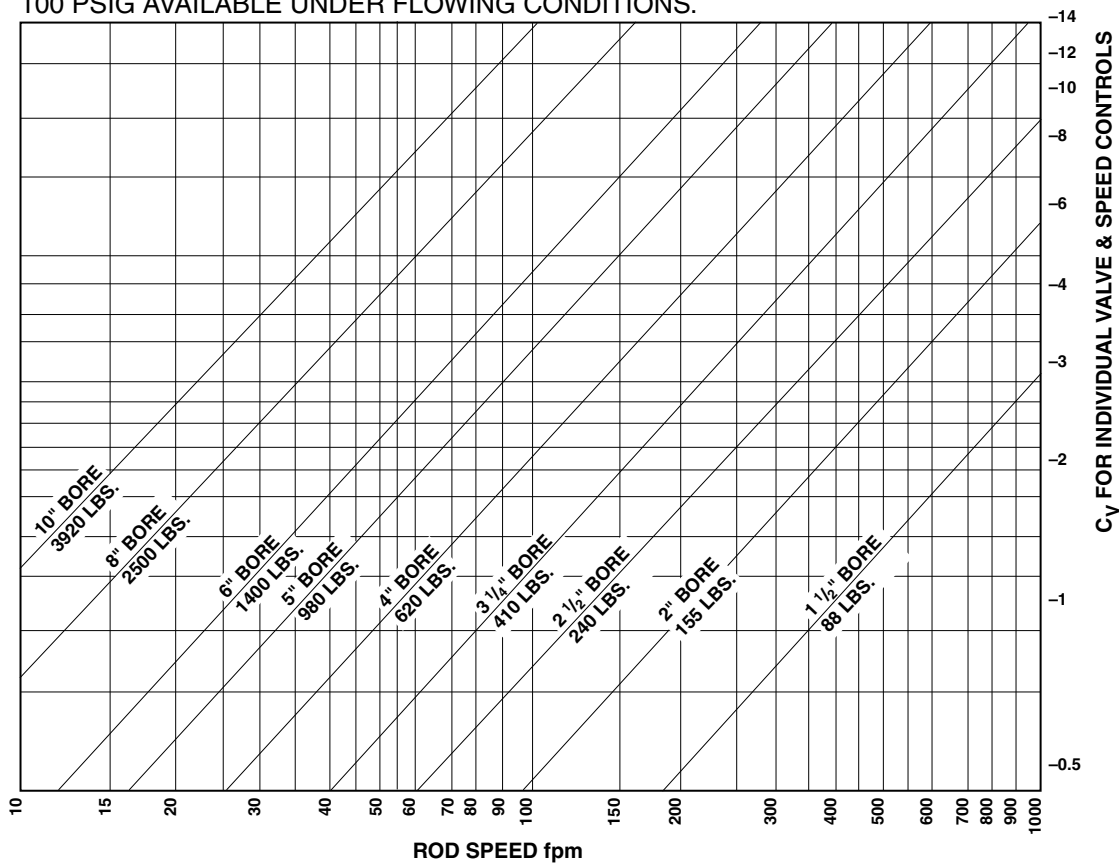

Table B-8 — Thrust Developed

| Bore Size | 1½ | 2 | 2½ | 3¼ | 4 | 5 | 6 | 8 | 10 |
|-----------------------|-----|-----|-----|-----|------|------|------|------|------|
| Dynamic Thrust (lbs.) | 88 | 155 | 240 | 410 | 620 | 980 | 1400 | 2500 | 3920 |
| Static Thrust (lbs.) | 177 | 314 | 491 | 830 | 1250 | 1960 | 2820 | 5020 | 7850 |

Miller AV Series Heavy-Duty Air Cylinders

3. Read upward on appropriate rod speed line to intersection with diagonal cylinder bore line. Read right from intersection point to determine the required Cv of the valve and the speed controls. Both the valve and speed controls must have this Cv.

The following examples illustrate use of the graphs:

Example 1: Assume it is necessary to raise a 900 lb. load 24 inches in two seconds. With 100 psig maintained at the inlet to the F-R-L, use Graph B-4. The 5-inch bore cylinder is capable of developing the required thrust while in motion. Since 24 inches in two seconds is equal to 60 fpm, read upward on the 60 fpm line to the intersection of the 5-inch bore diagonal line. Reading to the right indicates that the required valve and speed controls must each have a Cv of over 1.9.

Example 2: Assume similar conditions to Example 1, except that only 80 psig will be available under flowing conditions. Using Graph B-5, a 6-inch bore cylinder is indicated. Read upward on the 60 fpm line to the intersection point. Interpolation of the right-hand scale indicates a required valve and speed control Cv of over 2.8.

Example 3: Assume similar conditions to Example 1, except that the load is being moved in a horizontal plane with a coefficient of sliding friction of 0.2. Only a 180 lb. thrust is now required (900 lb. x 0.2). Consult Graph B-4. The 2½ inch bore cylinder will develop sufficient thrust, and at 60 fpm requires a valve and speed control Cv of about

Graph B-5 — This graph is determined by having 80 psig available under flowing conditions.

THIS GRAPH IS DETERMINED BY HAVING 80 PSIG AVAILABLE UNDER FLOWING CONDITIONS.

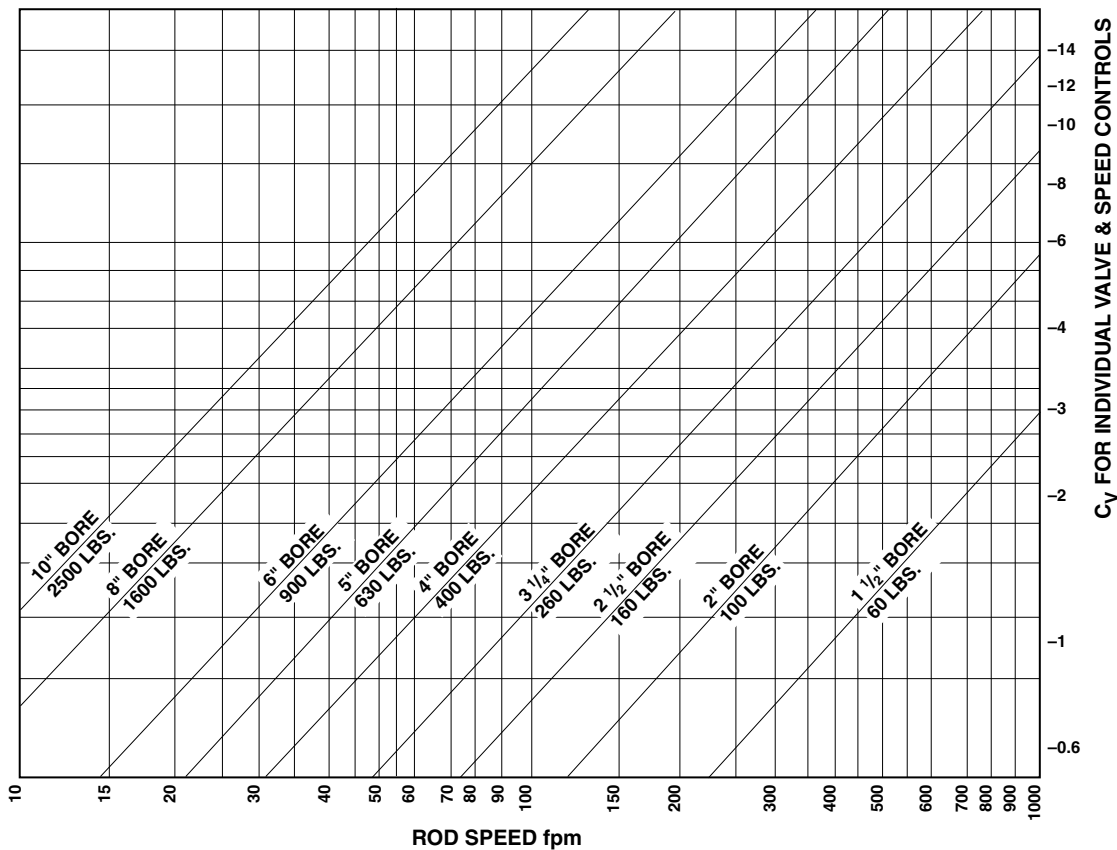

Table B-9 — Thrust Developed

| Bore Size | 1½ | 2 | 2½ | 3¼ | 4 | 5 | 6 | 8 | 10 |
|-----------------------|-----|-----|-----|-----|------|------|------|------|------|
| Dynamic Thrust (lbs.) | 60 | 100 | 160 | 260 | 400 | 630 | 900 | 1600 | 2500 |
| Static Thrust (lbs.) | 141 | 251 | 393 | 663 | 1000 | 1570 | 2260 | 4010 | 6280 |

Miller AV Series Heavy-Duty Air Cylinders

Notes

NOTES

Miller AV Series Heavy-Duty Air Cylinders

Mounting
Parts Identification

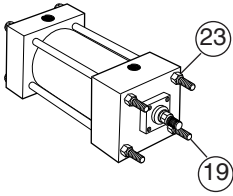
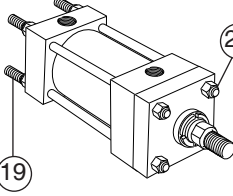
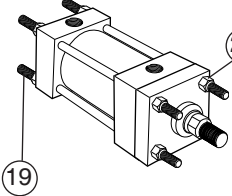
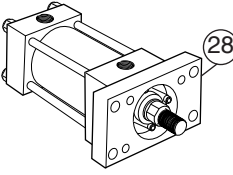
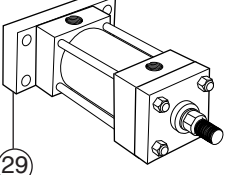
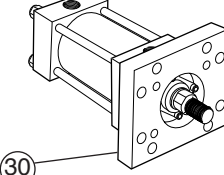
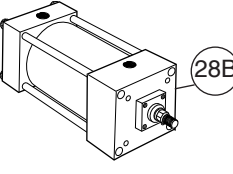
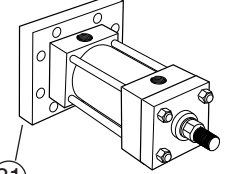
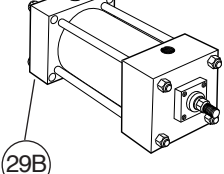
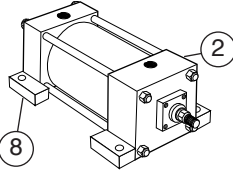
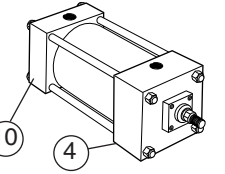
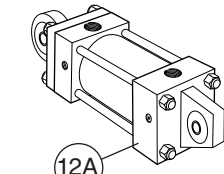
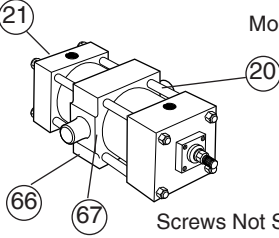
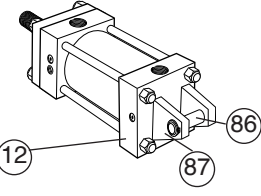
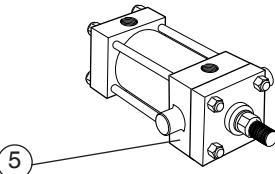
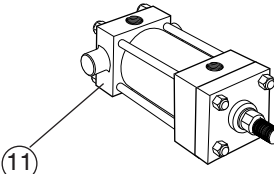
| | | | Replacement Mountings & Hardware | |
|---|---|---|---|--|
| | | | Symbol | Description |
| Model 53  | Model 52  | Model 51  | | |
| Model 61  | Model 62  | Model 65  | | |
| Model 63  7" thru 14" Bore | Model 66  | Model 64  7" thru 14" Bore | | |
| Model 72  | Model 74  | Model 94  | | |
| Model 89  Screws Not Shown | Model 84  | | | |
| Model 81  | Model 82  | | | |
| | | | | <p>How to Order Give cylinder model number, bore, stroke, serial number and symbol number shown above to insure proper replacement.</p> |

Miller AV Series Heavy-Duty Air Cylinders

Parts Identification

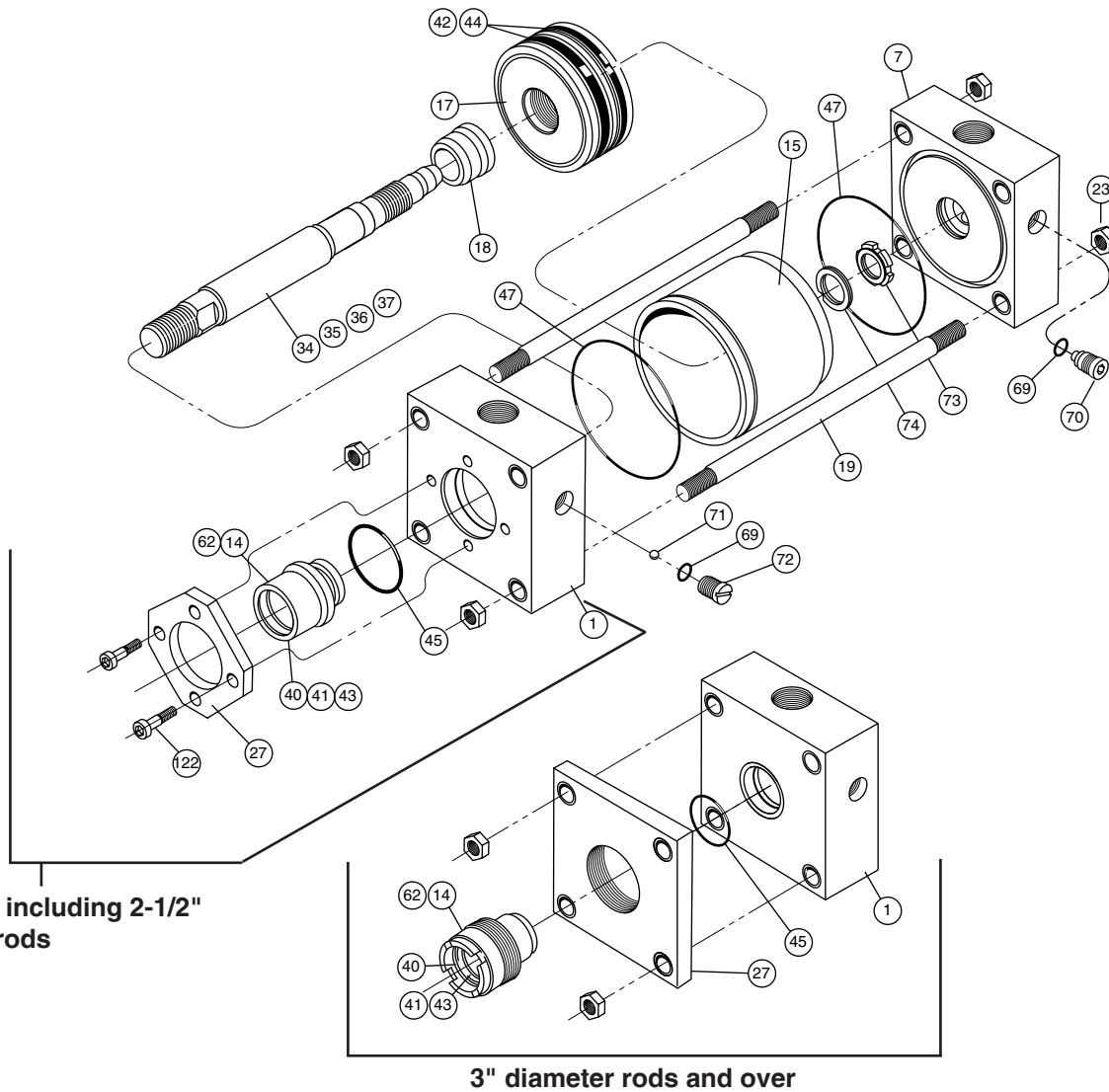

Double End Rod and Piston Assembly

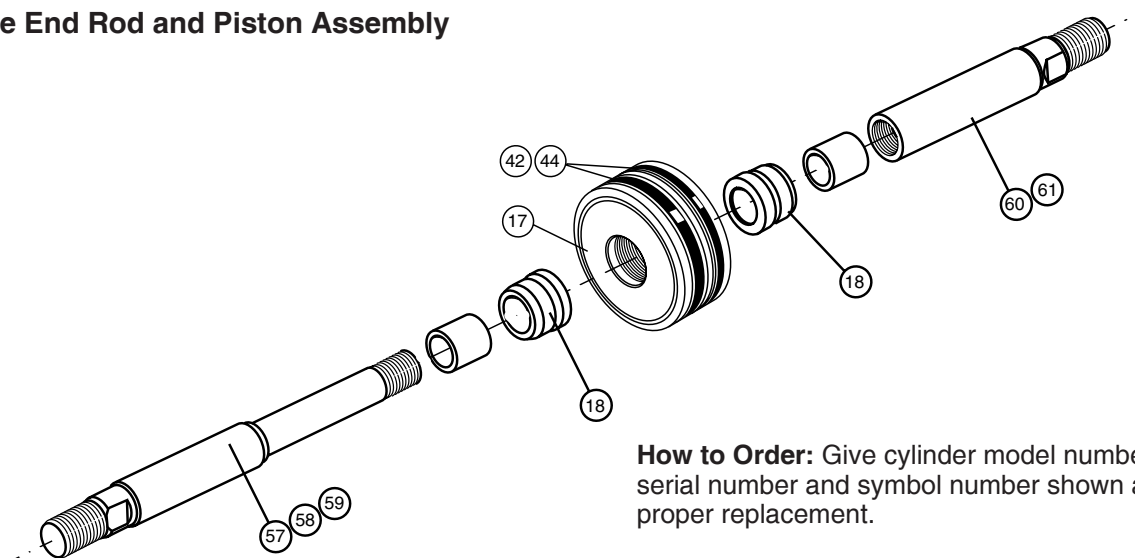

Miller AV Series Heavy-Duty Air Cylinders

Parts Identification
Cushion Kits

| Parts | | Assemblies (Includes Symbol Numbers Shown) | | |
|--------|---|--|--|--|
| Symbol | Description | Symbol | Description | Lipseal Type Piston |
| 1 | Head, ported, non-cushioned | C1SA | Head, ported, cushioned | 1, 69, 70, 71 & 72 |
| 7 | Cap, ported, non-cushioned | C7SA | Cap, ported, cushioned | 7, 69, 70, 73 & 74 |
| 14 | Bushing | 62 | Bushing kit | 14, 40, 41, 43 & 45 |
| 15 | Tube | - | - | - |
| 17 | Piston, lipseal type | - | - | - |
| 18 | Cushion plunger, cushioned cylinder only | - | - | - |
| 19 | Tie rod | - | - | - |
| 23 | Tie rod nut | - | - | - |
| 27 | Retainer | - | - | - |
| 34 | Piston rod, single rod type, non-cushioned | 34SA | Piston & rod assembly, single rod type — non-cushioned | 17, 34, 42 & 44 |
| 35 | Piston rod, single rod type, cushioned head end | 35SA | Piston & rod assembly, single rod type — cush. head end | 17, 18, 35, 42 & 44 |
| 36 | Piston rod, single rod type, cushioned cap end | 36SA | Piston & rod assembly, single rod type — cush. cap end | 17, 36, 42 & 44 |
| 37 | Piston rod, single rod type, cushioned both ends | 37SA | Piston & rod assembly, single rod type — cush. both ends | 17, 18, 37, 42 & 44 |
| 40 | Rod wiper | - | - | - |
| 41 | Rod seal | - | - | - |
| 42 | Piston seal | - | - | - |
| 43 | Back-up washer, bushing | - | Seal Kits | - |
| 44 | Back-up washer, piston | - | | - |
| 45 | O-ring, bushing to head seal | - | | - |
| 47 | O-ring, cylinder tube end seal | - | | - |
| 57 | Piston rod, double rod type, non-cushioned | 57SA | | Piston & Rod assembly, double rod type — non-cush. |
| 58 | Piston rod, double rod type, cushioned one end | 58SA | Piston & rod assembly, double rod type — cush. one end | 17, 18, 42, 44, 58 & 60 |
| 59 | Piston rod, double rod type, cushioned both ends | 59SA | Piston & rod assembly, double rod type — cush. both ends | 17, 18, 42, 44, 58 & 61 |
| 60 | Piston rod extension, double rod type — non-cushioned | - | - | - |
| 61 | Piston Rod extension, double rod type — cushioned | - | - | - |
| 69 | O-ring, cushion adjustment & check valve screw | - | - | - |
| 70 | Needle valve, cushion adjustment | - | Cushion Kits See table below. | - |
| 71 | Ball, check valve | - | | - |
| 72 | Plug screw, check valve | - | | - |
| 73 | Cushion bushing, cap end floating check valve | - | | - |
| 74 | Retaining ring, floating cushion bushing | - | - | - |
| 122 | Socket cap screws | - | - | - |

Standard Cushion Hardware Kits

| Bore Size | Rod Ø | For Head Assemblies | For Cap Assemblies |
|-----------|-------------|--|---|
| | | Order Kits by Number Below: (Kits Include Symbols 69, 70, 71 & 72 for One Head) | Order Kits by Number Below: (Kits Include Symbols 69, 70, 73 & 74 for One Cap) |
| 1 | None | None | None |
| 1½ | 5/8 | AV-CUKH1-1 | AV-CUKC1-4 |
| | 1 | AV-CUKH1-1M | |
| 2 | 5/8, 1 | AV-CUKH1-1 | AV-CUKC1-4 |
| | 1 3/8 | AV-CUKH1-1M | |
| 2½ | 5/8, 1, A | AV-CUKH1-1 | AV-CUKC1-4 |
| | 1 3/4 | AV-CUKH1-1M | |
| 3¼ | All | AV-CUKH1-2 | AV-CUKC1-5 |
| 4 | All | AV-CUKH1-2 | AV-CUKC1-5 |
| 5 | All | AV-CUKH1-2A | AV-CUKC1-5A |
| 6 | 1 3/8-3 1/2 | AV-CUKH1-3 | AV-CUKC1-6 |
| | 4 | AV-CUKH1-2 | AV-CUKC1-6A |
| 7 | All | AV-CUKH1-3 | AV-CUKC1-6 |
| 8 | All | AV-CUKH1-3 | AV-CUKC1-6 |
| 10 | All | AV-CUKH1-3 | AV-CUKC1-7 |
| 12 | All | AV-CUKH1-3 | AV-CUKC1-8 |
| 14 | All | AV-CUKH1-3 | AV-CUKC1-9 |

Fluorocarbon Cushion Hardware Kits

| Bore Size | Rod Ø | For Head Assemblies | For Cap Assemblies |
|-----------|---------------|---|---|
| | | Order Kits by Number Below: (Kits Include Symbols 69, 70, 71 & 72) | Order Kits by Number Below: (Kits Include Symbols 69, 70, 73 & 74) |
| 1 | None | None | None |
| 1½ | 5/8 | AV-CUKH5-18 | AV-CUKC5-22 |
| | 1 | AV-CUKH5-18M | |
| 2 | 5/8, 1 | AV-CUKH5-18 | AV-CUKC5-22 |
| | 1 3/8 | AV-CUKH5-18M | |
| 2½ | 5/8, 1, 1 3/8 | AV-CUKH5-18 | AV-CUKC5-22 |
| | 1 3/4 | AV-CUKH5-18M | |
| 3¼ | All | AV-CUKH5-19 | AV-CUKC5-23 |
| 4 | All | AV-CUKH5-19 | AV-CUKC5-23 |
| 5 | All | AV-CUKH5-19A | AV-CUKC5-23A |
| 6 | 1 3/8-3 1/2 | AV-CUKH5-21 | AV-CUKC5-24 |
| | 4 | AV-CUKH5-19 | AV-CUKC5-24A |
| 7 | All | AV-CUKH5-21 | AV-CUKC5-24 |
| 8 | All | AV-CUKH5-21 | AV-CUKC5-24 |
| 10 | All | AV-CUKH5-21 | AV-CUKC5-25 |
| 12 | All | AV-CUKH5-21 | AV-CUKC5-26 |
| 14 | All | AV-CUKH5-21 | AV-CUKC5-27 |

Miller AV Series Heavy-Duty Air Cylinders

Parts Identification
Seal Kits
Standard Seals

| Symbol | Description |
|--------|------------------------|
| 14 | Bushing |
| 40 | Rod wiper |
| 41 | Rod seal |
| 42 | Piston lipseal |
| 43 | Bushing back-up washer |
| 44 | Piston back-up washer |
| 45 | Bushing to head o-ring |
| 47 | End seal o-ring |
| 62 | Bushing kit |

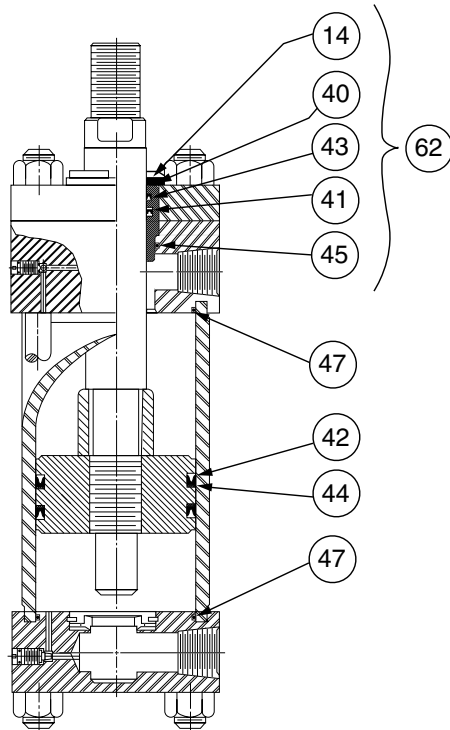

Seal Kits for Class 1 Service

Material: Buna-N (Nitrile)

For operating temperature and fluid compatibility, see "Operating Fluids and Temperature Range" page.

Bushing and spanner wrenches are available to ease (rod) seal or bushing removal without disassembly of the cylinder. **(For rod diameters over 2 1/2".)**

For detailed seal replacement instructions see service bulletin M0995-M1, M2 and M3.

| Rod Ø | Bushing Kits (Symbol 62) Contains Symbols 14, 40, 41, 43 & 45 | Rod Seal Kits Contains Symbols 40, 41, 43 & 45 | Bushing Wrench | Spanner Wrench |
|-------|---|--|----------------|----------------|
| 1/2 | AV-KR100-50 | AV-KR300-50 | Not Required | Not Required |
| 5/8 | AV-KR100-63 | AV-KR300-63 | | |
| 1 | AV-KR100-100 | AV-KR300-100 | | |
| 1 3/8 | AV-KR100-138 | AV-KR300-138 | | |
| 1 3/4 | AV-KR100-175 | AV-KR300-175 | | |
| 2 | AV-KR100-200 | AV-KR300-200 | | |
| 2 1/2 | AV-KR100-250 | AV-KR300-250 | 069596 0000 | 011677 0000 |
| 3 | AV-KR100-300 | AV-KR300-300 | 069597 0000 | 011677 0000 |
| 3 1/2 | AV-KR100-350 | AV-KR300-350 | 069598 0000 | 011678 0000 |
| 4 | AV-KR100-400 | AV-KR300-400 | 083877 0000 | 011678 0000 |
| 4 1/2 | AV-KR100-450 | AV-KR300-450 | 069599 0000 | 011678 0000 |
| 5 | AV-KR100-500 | AV-KR300-500 | 069600 0000 | 011678 0000 |
| 5 1/2 | AV-KR100-550 | AV-KR300-550 | | |

| Bore Size | Piston Seal Kits Contains 2 Each Symbols: 42, 44 & 47 |
|-----------|---|
| 1 | AV-KB100-100 |
| 1 1/2 | AV-KB100-150 |
| 2 | AV-KB100-200 |
| 2 1/2 | AV-KB100-250 |
| 3 1/4 | AV-KB100-325 |
| 4 | AV-KB100-400 |
| 5 | AV-KB100-500 |
| 6 | AV-KB100-600 |
| 7 | AV-KB100-700 |
| 8 | AV-KB100-800 |
| 10 | AV-KB100-1000 |
| 12 | AV-KB100-1200 |
| 14 | AV-KB100-1400 |

| Bore Size | Cylinder Tube Seal Kits Contains 2 Each Symbol 47 | Tie Rod Torque Specifications (Ft. Lbs.) |
|-----------|---|--|
| | | AV Series Steel Cylinder Tube |
| 1 | AV-ES100-100 | 2 |
| 1 1/2 | AV-ES100-150 | 5 |
| 2 | AV-ES100-200 | 11 |
| 2 1/2 | AV-ES100-250 | 11 |
| 3 1/4 | AV-ES100-325 | 25 |
| 4 | AV-ES100-400 | 25 |
| 5 | AV-ES100-500 | 60 |
| 6 | AV-ES100-600 | 60 |
| 7 | AV-ES100-700 | 90 |
| 8 | AV-ES100-800 | 110 |
| 10 | AV-ES100-1000 | 150 |
| 12 | AV-ES100-1200 | 172 |
| 14 | AV-ES100-1400 | 275 |

How to Order

Individual seals contained in the kits are available separately; however, we recommend purchasing complete kits because of convenience and lower replacement cost. When ordering seal kits, give part number listed above. To be sure of exact replacement, give serial number of cylinder when ordering replacement kits or seals.

Miller AV Series Heavy-Duty Air Cylinders

Parts Identification
Seal Kits
Group 5 Service

| Symbol | Description |
|--------|------------------------|
| 14 | Bushing |
| 40 | Rod wiper |
| 41 | Rod seal |
| 42 | Piston lipseal |
| 43 | Bushing back-up washer |
| 44 | Piston back-up washer |
| 45 | Bushing to head o-ring |
| 47 | End seal o-ring |
| 62 | Bushing kit |

Seal Kits for Class 5 Service

Material: Fluorocarbon

For operating temperature and fluid compatibility, see "Operating Fluids and Temperature Range" page.

Bushing and spanner wrenches are available to ease (rod) seal or bushing removal without disassembly of the cylinder. **(For rod diameters over 2 1/2".)**

For detailed seal replacement instructions see service bulletin M0995-M1, M3 and M5.

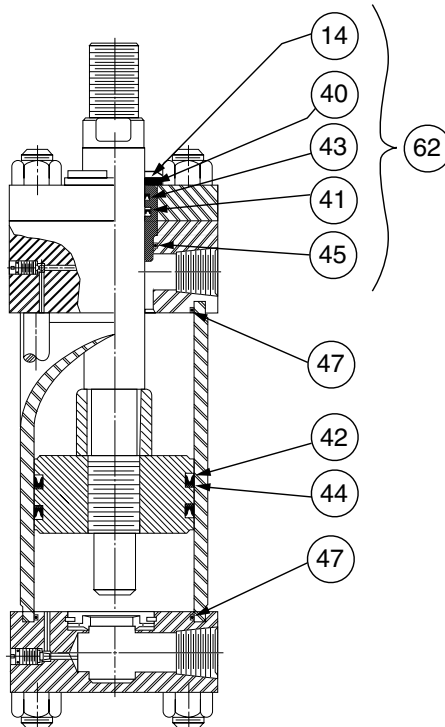

| Rod Ø | Bushing (Symbol 62) Kits Contains Symbols 14, 40, 41, 43 & 45 | Rod Seal Kits Contains Symbols 40, 41, 43 & 45 | Bushing Wrench | Spanner Wrench | | |
|-------|---|--|----------------|----------------|-------------|-------------|
| 1/2 | AV-KR200-50 | AV-KR400-50 | Not Required | Not Required | | |
| 5/8 | AV-KR200-63 | AV-KR400-63 | | | | |
| 1 | AV-KR200-100 | AV-KR400-100 | | | | |
| 1 3/8 | AV-KR200-138 | AV-KR400-138 | | | | |
| 1 3/4 | AV-KR200-175 | AV-KR400-175 | | | | |
| 2 | AV-KR200-200 | AV-KR400-200 | | | | |
| 2 1/2 | AV-KR200-250 | AV-KR400-250 | 069596 0000 | 011677 0000 | | |
| 3 | AV-KR200-300 | AV-KR400-300 | | | | |
| 3 1/2 | AV-KR200-350 | AV-KR400-350 | | | | |
| 4 | AV-KR200-400 | AV-KR400-400 | | | | |
| 4 1/2 | AV-KR200-450 | AV-KR400-450 | | | | |
| 5 | AV-KR200-500 | AV-KR400-500 | | | | |
| 5 1/2 | AV-KR200-550 | AV-KR400-550 | | | | |
| | | | | | 069597 0000 | 011677 0000 |
| | | | | | 069598 0000 | 011678 0000 |
| | | | | | 083877 0000 | 011678 0000 |

| Bore Size | Piston Seal Kits Contains 2 Each Symbols: 42, 44 & 47 |
|-----------|---|
| 1 | AV-KB200-100 |
| 1 1/2 | AV-KB200-150 |
| 2 | AV-KB200-200 |
| 2 1/2 | AV-KB200-250 |
| 3 1/4 | AV-KB200-325 |
| 4 | AV-KB200-400 |
| 5 | AV-KB200-500 |
| 6 | AV-KB200-600 |
| 7 | AV-KB200-700 |
| 8 | AV-KB200-800 |
| 10 | AV-KB200-1000 |
| 12 | AV-KB200-1200 |
| 14 | AV-KB200-1400 |

| Bore Size | Tube Seal Kits Contains 2 Each Symbol 47 | Tie Rod Torque Specifications (Ft. Lbs.) |
|-----------|--|--|
| | | AV Series Steel Cylinder Tube |
| 1 | AV-ES200-100 | 2 |
| 1 1/2 | AV-ES200-150 | 5 |
| 2 | AV-ES200-200 | 11 |
| 2 1/2 | AV-ES200-250 | 11 |
| 3 1/4 | AV-ES200-325 | 25 |
| 4 | AV-ES200-400 | 25 |
| 5 | AV-ES200-500 | 60 |
| 6 | AV-ES200-600 | 60 |
| 7 | AV-ES200-700 | 90 |
| 8 | AV-ES200-800 | 110 |
| 10 | AV-ES200-1000 | 150 |
| 12 | AV-ES200-1200 | 172 |
| 14 | AV-ES200-1400 | 275 |

How to Order

Individual seals contained in the kits are available separately; however, we recommend purchasing complete kits because of convenience and lower replacement cost. When ordering seal kits, give part number listed above. To be sure of exact replacement, give serial number of cylinder when ordering replacement kits or seals.

Miller AVN Series Heavy-Duty Air Cylinders

AVN Series
Seal Kits
Parts Identification

Standard Seals — Class 1 Service Kits are standard. In addition to standard seals, each kit includes the special composite components ready for installation. These seals are suitable for use when air is the operating medium.

The recommended operating temperature range for Class 1 seals is -10° F to +165°F.

Seal Kits

Bushing Kit

| Rod Size | Contains Symbols 14, 40, 41 & 45 |
|----------|-------------------------------------|
| 5/8 | AVN-KR100-63 |
| 1 | AVN-KR100-100 |
| 1 3/8 | AVN-KR100-138 |
| 1 3/4 | AVN-KR100-175 |
| 2 | AVN-KR100-200 |

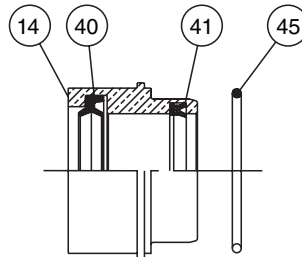

Rod Seal Kit

| Rod Size | Contains Symbols 40, 41 & 45 |
|----------|---------------------------------|
| 5/8 | AVN-KR300-63 |
| 1 | AVN-KR300-100 |
| 1 3/8 | AVN-KR300-138 |
| 1 3/4 | AVN-KR300-175 |
| 2 | AVN-KR300-200 |

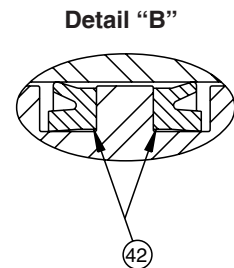
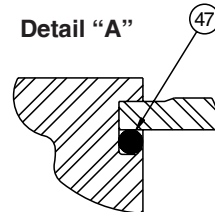
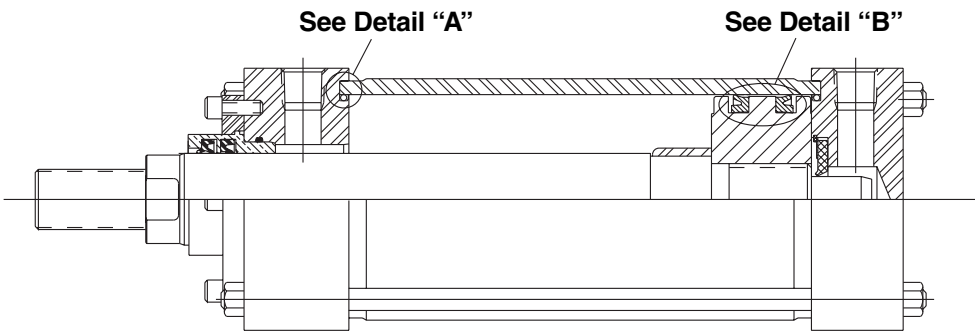

| Bore Size | Piston Seal Kit Consisting of 2 Ea. Symbol 42 & 47 | Cylinder Tube Seal Kit Consisting of 2 Ea. Symbol 47 |
|-----------|--|--|
| 1 1/2 | AVN-KB100-150 | AVN-ES100-150 |
| 2 | AVN-KB100-200 | AVN-ES100-200 |
| 2 1/2 | AVN-KB100-250 | AVN-ES100-250 |
| 3 1/4 | AVN-KB100-325 | AVN-ES100-325 |
| 4 | AVN-KB100-400 | AVN-ES100-400 |
| 5 | AVN-KB100-500 | AVN-ES100-500 |
| 6 | AVN-KB100-600 | AVN-ES100-600 |
| 7 | AVN-KB100-700 | AVN-ES100-700 |
| 8 | AVN-KB100-800 | AVN-ES100-800 |
| 10 | AVN-KB100-1000 | AVN-ES100-1000 |

Miller AV Series Heavy-Duty Air Cylinders

Notes

NOTES

Miller AV Series Heavy-Duty Air Cylinders

Model Numbers

How to Order AV Series Cylinders

Data Required On All Cylinder Orders

When ordering AV Series cylinders, be sure to specify each of the following requirements:

(NOTE: – Duplicate cylinders can be ordered by giving the SERIAL NUMBER from the original cylinder. Factory records supply a quick, positive identification.)

a) Series Designation (“AV”)

b) Mounting Model

Specify your choice of mounting – as shown and dimensioned in this catalog.

c) Bushing Style (“B” or “R”)

d) Piston Rod End Thread Style

Call out thread style number. Thread style 2 will be furnished if not otherwise supplied. For special rod ends specify style “X” as indicated below.

e) Cushions (if required)

Specify “Cushion-head end,” “Cushion-cap end” or “Cushion-both ends” as required. If cylinder is to have a double rod and only one cushion is required, be sure to specify clearly which end of the cylinder is to be cushioned.

f) Bore Size

g) Length of Stroke

h) Piston Rod Diameter

Call out rod diameter. In AV Series cylinders, standard rod diameters will be furnished if not otherwise specified, unless length of stroke makes the application questionable.

i) Ports

NPTF is standard.

j) Port Locations

k) Modifications

Any modifications that are not identified in the cylinder number shown on the following page should be added to the specifications. These can include special fluids, special seals, air bleeds, double rod cylinder with different rod end styles and diameters. For further information consult factory.

Style X Rod End

A style X rod end indicates a special rod end configuration. All special rod ends must be described by at least **all three**: KK; A; or W/WF specified with the rod fully retracted. A sketch or drawing should be submitted for rod ends requiring special machining such as snap ring grooves,

keyways, tapers, multiple diameters, etc. It is good design practice to have this machining done on a diameter at least 0.065 inches smaller than the piston rod diameter. This allows the piston rod to have a chamfer preventing rod seal damage during assembly or maintenance.

Service Policy

When cylinders are returned to the factory for repairs, it is standard policy for Miller Fluid Power to make such part replacements as will put the cylinder in as good as new condition. Should the condition of the returned cylinder be such that expenses for repair exceed the cost of a new one, you will be notified.

Certified Dimensions

Miller Fluid Power guarantees that all cylinders ordered from this catalog will be built to dimensions shown. All dimensions are certified to be correct, and thus it is not necessary to request certified drawings.

Miller AV Series Heavy-Duty Air Cylinders

How To Order

How to Order – Example: AV72B2N-04.00-8.000-0138 N11-0

| Series | Mounting Style | Bushing | Rod End Style | Cushions | Bore Dia. | Stroke | Rod Dia. | Port Type | Port Location | | Modified |
|---|----------------|---|---------------------------------------|--|-----------|--------|----------|-----------|-------------------------------------|-----------------------------|-------------------------------|
| AV DAV (D = Dbl. Rod End AVN (N = Non-Lube) DAVN | | B = Bolted Bushing R = Retainer Held Bushing | 2 (Standard) 4 5 X (Special) | R = Rod End Cushioned C = Cap End Cushioned B = Both Ends Cushioned N = Non-Cushioned | | | | N = NPTF | Head End 1 (Std.) 2 3 4 | Cap End 1 2 3 4 | 0 = Standard 9* = Modified |

9* The number 9 refers to special options or modifications that deviate from the standard product offering. Non-standard modifications and options not identified in the cylinder model number should be added in the notes when placing an order.

Modifications which can be placed under the designator “9” are as follows:

- Fluorocarbon Seals – for applications which experience operating temperatures up to and including 250°F
- Multiple Ports
- Special Port Threads
- Cushion Location
- Special Mounts

Note: The standard #1 port location is at the top of the cylinder, and the standard cushion adjustment screw is in position #2 when facing the rod end of the cylinder. If multiple ports are required, the last number of the part number should be “9”, indicating modified and the desired port location specified in the notes.

Cushions not available on 1" bore.

| Rod Ø | RD Across Corners |
|---------------------------------|---------------------------------|
| 5/8" | 1 ⁶³ / ₆₄ |
| 1" | 2 ³¹ / ₆₄ |
| 1 ³ / ₈ " | 2 ⁶³ / ₆₄ |
| 1 ³ / ₄ " | 3 ⁴¹ / ₆₄ |
| 2" | 3 ³ / ₄ |
| 2 ¹ / ₂ " | 4 ²¹ / ₆₄ |

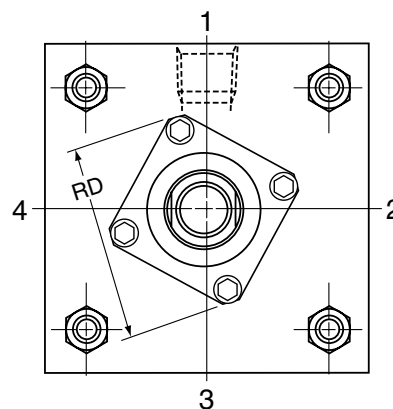

Miller AV Series Heavy-Duty Air Cylinders

Safety Guide for Selecting and Using Hydraulic, Pneumatic Cylinders and Their Accessories

WARNING: ⚠️ **FAILURE OF THE CYLINDER, ITS PARTS, ITS MOUNTING, ITS CONNECTIONS TO OTHER OBJECTS, OR ITS CONTROLS CAN RESULT IN:**

- Unanticipated or uncontrolled movement of the cylinder or objects connected to it.
- Falling of the cylinder or objects held up by it.
- Fluid escaping from the cylinder, potentially at high velocity.

THESE EVENTS COULD CAUSE DEATH OR PERSONAL INJURY BY, FOR EXAMPLE, PERSONS FALLING FROM HIGH LOCATIONS, BEING CRUSHED OR STRUCK BY HEAVY OR FAST MOVING OBJECTS, BEING PUSHED INTO DANGEROUS EQUIPMENT OR SITUATIONS, OR SLIPPING ON ESCAPED FLUID.

Before selecting or using Parker Hannifin Corporation (the Company) cylinders or related accessories, it is important that you read, understand and follow the following safety information. Training is advised before selecting and using the Company's products.

1.0 General Instructions

1.1 Scope – This safety guide provides instructions for selecting and using (including assembling, installing, and maintaining) cylinder products. This safety guide is a supplement to and is to be used with the specific Company publications for the specific cylinder products that are being considered for use.

1.2 Fail Safe – Cylinder products can and do fail without warning for many reasons. All systems and equipment should be designed in a fail-safe mode so that if the failure of a cylinder product occurs people and property won't be endangered.

1.3 Distribution – Provide a free copy of this safety guide to each person responsible for selecting or using cylinder products. Do not select or use the Company's cylinders without thoroughly reading and understanding this safety guide as well as the specific Company publications for the products considered or selected.

1.4 User Responsibility – Due to very wide variety of cylinder applications and cylinder operating conditions, the Company does not warrant that any particular cylinder is suitable for any specific application. This safety guide does not analyze all technical parameters that must be considered in selecting a product. The hydraulic and pneumatic cylinders outlined in this catalog are designed to the Company's design guidelines and do not necessarily meet the design guideline of other agencies such as American Bureau of Shipping, ASME Pressure Vessel Code etc. The user, through its own analysis and testing, is solely responsible for:

- Making the final selection of the cylinders and related accessories.
- Determining if the cylinders are required to meet specific design requirements as required by the Agency(s) or industry standards covering the design of the user's equipment.
- Assuring that the user's requirements are met, OSHA requirements are met, and safety guidelines from the applicable agencies such as but not limited to ANSI are followed and that the use presents no health or safety hazards.
- Providing all appropriate health and safety warnings on the equipment on which the cylinders are used.

1.5 Additional Questions – Call the appropriate Company technical service department if you have any questions or require any additional information. See the Company publication for the product being considered or used, or call 1-847-298-2400, or go to www.parker.com, for telephone numbers of the appropriate technical service department.

2.0 Cylinder and Accessories Selection

2.1 Seals – Part of the process of selecting a cylinder is the selection of seal compounds. Before making this selection, consult the "seal information page(s)" of the publication for the series of cylinders of interest.

The application of cylinders may allow fluids such as cutting fluids, wash down fluids etc. to come in contact with the external area of the cylinder. These fluids may attack the piston rod wiper and or the primary seal and must be taken into account when selecting and specifying seal compounds.

Dynamic seals will wear. The rate of wear will depend on many operating factors. Wear can be rapid if a cylinder is mis-aligned or if the cylinder has been improperly serviced. The user must take seal wear into consideration in the application of cylinders.

2.2 Piston Rods – Possible consequences of piston rod failure or separation of the piston rod from the piston include, but are not limited to are:

- Piston rod and or attached load thrown off at high speed.
- High velocity fluid discharge.
- Piston rod extending when pressure is applied in the piston retract mode.

Piston rods or machine members attached to the piston rod may move suddenly and without warning as a consequence of other conditions occurring to the machine such as, but not limited to:

- Unexpected detachment of the machine member from the piston rod.

- Failure of the pressurized fluid delivery system (hoses, fittings, valves, pumps, compressors) which maintain cylinder position.
- Catastrophic cylinder seal failure leading to sudden loss of pressurized fluid.
- Failure of the machine control system.

Follow the recommendations of the "Piston Rod Selection Chart and Data" in the publication for the series of cylinders of interest. The suggested piston rod diameter in these charts must be followed in order to avoid piston rod buckling.

Piston rods are not normally designed to absorb bending moments or loads which are perpendicular to the axis of piston rod motion. These additional loads can cause the piston rod to fail. If these types of additional loads are expected to be imposed on the piston rod, their magnitude should be made known to our engineering department.

The cylinder user should always make sure that the piston rod is securely attached to the machine member.

On occasion cylinders are ordered with double rods (a piston rod extended from both ends of the cylinder). In some cases a stop is threaded on to one of the piston rods and used as an external stroke adjuster. On occasions spacers are attached to the machine member connected to the piston rod and also used as a stroke adjuster. In both cases the stops will create a pinch point and the user should consider appropriate use of guards. If these external stops are not perpendicular to the mating contact surface, or if debris is trapped between the contact surfaces, a bending moment will be placed on the piston rod, which can lead to piston rod failure. An external stop will also negate the effect of cushioning and will subject the piston rod to impact loading. Those two (2) conditions can cause piston rod failure. Internal stroke adjusters are available with and without cushions. The use of external stroke adjusters should be reviewed with our engineering department.

The piston rod to piston and the stud to piston rod threaded connections are secured with an anaerobic adhesive. The strength of the adhesive decreases with increasing temperature. Cylinders which can be exposed to temperatures above +250°F (+121°C) are to be ordered with a non studded piston rod and a pinned piston to rod joint.

2.3 Cushions – Cushions should be considered for cylinder applications when the piston velocity is expected to be over 4 inches/second.

Cylinder cushions are normally designed to absorb the energy of a linear applied load. A rotating mass has considerably more energy than the same mass moving in a linear mode. Cushioning for a rotating mass application should be reviewed by our engineering department.

2.4 Cylinder Mountings – Some cylinder mounting configurations may have certain limitations such as but not limited to minimum stroke for side or foot mounting cylinders or pressure de-ratings for certain mounts. Carefully review the catalog for these types of restrictions.

Always mount cylinders using the largest possible high tensile alloy steel socket head cap screws that can fit in the cylinder mounting holes and torque them to the manufacturer's recommendations for their size.

2.5 Port Fittings – Hydraulic cylinders applied with meter out or deceleration circuits are subject to intensified pressure at piston rod end.

The rod end pressure is approximately equal to:

$$\frac{\text{operating pressure} \times \text{effective cap end area}}{\text{effective rod end piston area}}$$

Contact your connector supplier for the pressure rating of individual connectors.

3.0 Cylinder and Accessories Installation and Mounting

3.1 Installation

3.1.1 – Cleanliness is an important consideration, and cylinders are shipped with the ports plugged to protect them from contaminants entering the ports. These plugs should not be removed until the piping is to be installed. Before making the connection to the cylinder ports, piping should be thoroughly cleaned to remove all chips or burrs which might have resulted from threading or flaring operations.

Miller AV Series Heavy-Duty Air Cylinders

3.1.2 – Cylinders operating in an environment where air drying materials are present such as fast-drying chemicals, paint, or weld splatter, or other hazardous conditions such as excessive heat, should have shields installed to prevent damage to the piston rod and piston rod seals.

3.1.3 – Proper alignment of the cylinder piston rod and its mating component on the machine should be checked in both the extended and retracted positions. Improper alignment will result in excessive rod gland and/or cylinder bore wear. On fixed mounting cylinders attaching the piston rod while the rod is retracted will help in achieving proper alignment.

3.1.4 – Sometimes it may be necessary to rotate the piston rod in order to thread the piston rod into the machine member. This operation must always be done with zero pressure being applied to either side of the piston. Failure to follow this procedure may result in loosening the piston to rod-threaded connection. In some rare cases the turning of the piston rod may rotate a threaded piston rod gland and loosen it from the cylinder head. Confirm that this condition is not occurring. If it does, re-tighten the piston rod gland firmly against the cylinder head.

For double rod cylinders it is also important that when attaching or detaching the piston rod from the machine member that the torque be applied to the piston rod end of the cylinder that is directly attaching to the machine member with the opposite end unrestrained. If the design of the machine is such that only the rod end of the cylinder opposite to where the rod attaches to the machine member can be rotated, consult the factory for further instructions.

3.2 Mounting Recommendations

3.2.1 – Always mount cylinders using the largest possible high tensile alloy steel socket head screws that can fit in the cylinder mounting holes and torque them to the manufacturer's recommendations for their size.

3.2.2 – Side-Mounted Cylinders – In addition to the mounting bolts, cylinders of this type should be equipped with thrust keys or dowel pins located so as to resist the major load.

3.2.3 – Tie Rod Mounting – Cylinders with tie rod mountings are recommended for applications where mounting space is limited. The standard tie rod extension is shown as BB in dimension tables. Longer or shorter extensions can be supplied. Nuts used for this mounting style should be torqued to the same value as the tie rods for that bore size.

3.2.4 – Flange Mount Cylinders – The controlled diameter of the rod gland extension on head end flange mount cylinders can be used as a pilot to locate the cylinders in relation to the machine. After alignment has been obtained, the flanges may be drilled for pins or dowels to prevent shifting.

3.2.5 – Trunnion Mountings – Cylinders require lubricated bearing blocks with minimum bearing clearances. Bearing blocks should be carefully aligned and rigidly mounted so the trunnions will not be subjected to bending moments. The rod end should also be pivoted with the pivot pin in line and parallel to axis of the trunnion pins.

3.2.6 – Clevis Mountings – Cylinders should be pivoted at both ends with centerline of pins parallel to each other. After cylinder is mounted, be sure to check to assure that the cylinder is free to swing through its working arc without interference from other machine parts.

4.0 Cylinder and Accessories Maintenance, Troubleshooting and Replacement

4.1 Storage – At times cylinders are delivered before a customer is ready to install them and must be stored for a period of time. When storage is required the following procedures are recommended.

4.1.1 – Store the cylinders in an indoor area which has a dry, clean and noncorrosive atmosphere. Take care to protect the cylinder from both internal corrosion and external damage.

4.1.2 – Whenever possible cylinders should be stored in a vertical position (piston rod up). This will minimize corrosion due to possible condensation which could occur inside the cylinder. This will also minimize seal damage.

4.1.3 – Port protector plugs should be left in the cylinder until the time of installation.

4.1.4 – If a cylinder is stored full of hydraulic fluid, expansion of the fluid due to temperature changes must be considered. Installing a check valve with free flow out of the cylinder is one method.

4.1.5 – When cylinders are mounted on equipment that is stored outside for extended periods, exposed unpainted surfaces, e.g. piston rod, must be coated with a rust-inhibiting compound to prevent corrosion.

4.2 Cylinder Trouble Shooting

4.2.1 – External Leakage

4.2.1.1 – Rod seal leakage can generally be traced to worn or damaged seals. Examine the piston rod for dents, gouges or score marks, and replace piston rod if surface is rough.

Rod seal leakage could also be traced to gland wear. If clearance is excessive, replace rod bushing and seal. Rod seal leakage can also be traced to seal deterioration. If seals are soft or gummy or brittle, check compatibility of seal material with lubricant used if air cylinder, or operating fluid if hydraulic cylinder. Replace with seal material, which is compatible with these fluids. If the seals are hard or have lost elasticity, it is usually due to exposure to temperatures in excess of 165°F. (+74°C). Shield the cylinder from the heat source to limit temperature to 350°F. (+177°C.) and replace with fluorocarbon seals.

4.2.1.2 – Cylinder body seal leak can generally be traced to loose tie rods. Torque the tie rods to manufacturer's recommendation for that bore size.

Excessive pressure can also result in cylinder body seal leak. Determine maximum pressure to rated limits. Replace seals and retorquer tie rods as in paragraph above. Excessive pressure can also result in cylinder body seal leak. Determine if the pressure rating of the cylinder has been exceeded. If so, bring the operating pressure down to the rating of the cylinder and have the tie rods replaced.

Pinched or extruded cylinder body seal will also result in a leak. Replace cylinder body seal and retorquer as in paragraph above.

Cylinder body seal leakage due to loss of radial squeeze which shows up in the form of flat spots or due to wear on the O.D. or I.D. – Either of these are symptoms of normal wear due to high cycle rate or length of service. Replace seals as per paragraph above.

4.2.2 – Internal Leakage

4.2.2.1 – Piston seal leak (by-pass) 1 to 3 cubic inches per minute leakage is considered normal for piston ring construction. Virtually no static leak with lipseal type seals on piston should be expected. Piston seal wear is a usual cause of piston seal leakage. Replace seals as required.

4.2.2.2 – With lipseal type piston seals excessive back pressure due to over-adjustment of speed control valves could be a direct cause of rapid seal wear. Contamination in a hydraulic system can result in a scored cylinder bore, resulting in rapid seal wear. In either case, replace piston seals as required.

4.2.2.3 – What appears to be piston seal leak, evidenced by the fact that the cylinder drifts, is not always traceable to the piston. To make sure, it is suggested that one side of the cylinder piston be pressurized and the fluid line at the opposite port be disconnected. Observe leakage. If none is evident, seek the cause of cylinder drift in other component parts in the circuit.

4.2.3 – Cylinder Fails to Move the Load

4.2.3.1 – Pneumatic or hydraulic pressure is too low. Check the pressure at the cylinder to make sure it is to circuit requirements.

4.2.3.2 – Piston Seal Leak – Operate the valve to cycle the cylinder and observe fluid flow at valve exhaust ports at end of cylinder stroke. Replace piston seals if flow is excessive.

4.2.3.3 – Cylinder is undersized for the load – Replace cylinder with one of a larger bore size.

4.3 Erratic or Chatter Operation

4.3.1 – Excessive friction at rod gland or piston bearing due to load misalignment – Correct cylinder-to-load alignment.

4.3.2 – Cylinder sized too close to load requirements – Reduce load or install larger cylinder.

4.3.3 – Erratic operation could be traced to the difference between static and kinetic friction. Install speed control valves to provide a back pressure to control the stroke.

4.4 Cylinder Modifications, Repairs, or Failed Component

– Cylinders as shipped from the factory are not to be disassembled and or modified. If cylinders require modifications, these modifications must be done at company locations or by the Company's certified facilities. The Industrial Cylinder Division Engineering Department must be notified in the event of a mechanical fracture or permanent deformation of any cylinder component (excluding seals). This includes a broken piston rod, tie rod, mounting accessory or any other cylinder component. The notification should include all operation and application details. This information will be used to provide an engineered repair that will prevent recurrence of the failure.

It is allowed to disassemble cylinders for the purpose of replacing seals or seal assemblies. However, this work must be done by strictly following all the instructions provided with the seal kits.

Miller AV Series Heavy-Duty Air Cylinders

Offer of Sale

Offer of Sale

The items described in this document and other documents and descriptions provided by Parker Hannifin Corporation, Hydraulics Group, and its authorized distributors ("Seller") are hereby offered for sale at prices to be established by Seller. This offer and its acceptance by any customer ("Buyer") shall be governed by all of the following Terms and Conditions. Buyer's order for any item described in its document, when communicated to Seller verbally, or in writing, shall constitute acceptance of this offer. All goods or work described will be referred to as "Products".

1. Terms and Conditions. Seller's willingness to offer Products, or accept an order for Products, to or from Buyer is expressly conditioned on Buyer's assent to these Terms and Conditions and to the terms and conditions found on-line at www.parker.com/saleterms/. Seller objects to any contrary or additional term or condition of Buyer's order or any other document issued by Buyer.

2. Price Adjustments; Payments. Prices stated on the reverse side or preceding pages of this document are valid for 30 days. After 30 days, Seller may change prices to reflect any increase in its costs resulting from state, federal or local legislation, price increases from its suppliers, or any change in the rate, charge, or classification of any carrier. The prices stated on the reverse or preceding pages of this document do not include any sales, use, or other taxes unless so stated specifically. Unless otherwise specified by Seller, all prices are F.O.B. Seller's facility, and payment is due 30 days from the date of invoice. After 30 days, Buyer shall pay interest on any unpaid invoices at the rate of 1.5% per month or the maximum allowable rate under applicable law.

3. Delivery Dates; Title and Risk; Shipment. All delivery dates are approximate and Seller shall not be responsible for any damages resulting from any delay. Regardless of the manner of shipment, title to any products and risk of loss or damage shall pass to Buyer upon tender to the carrier at Seller's facility (i.e., when it's on the truck, it's yours). Unless otherwise stated, Seller may exercise its judgment in choosing the carrier and means of delivery. No deferment of shipment at Buyer's request beyond the respective dates indicated will be made except on terms that will indemnify, defend and hold Seller harmless against all loss and additional expense. Buyer shall be responsible for any additional shipping charges incurred by Seller due to Buyer's changes in shipping, product specifications or in accordance with Section 13, herein.

4. Warranty. Seller warrants that the Products sold hereunder shall be free from defects in material or workmanship for a period of eighteen months from the date of delivery to Buyer. The prices charged for Seller's products are based upon the exclusive limited warranty stated above, and upon the following disclaimer: **DISCLAIMER OF WARRANTY: THIS WARRANTY COMPRISES THE SOLE AND ENTIRE WARRANTY PERTAINING TO PRODUCTS PROVIDED HEREUNDER. SELLER DISCLAIMS ALL OTHER WARRANTIES, EXPRESS AND IMPLIED, INCLUDING MERCHANTABILITY AND FITNESS FOR A PARTICULAR PURPOSE.**

5. Claims; Commencement of Actions. Buyer shall promptly inspect all Products upon delivery. No claims for shortages will be allowed unless reported to the Seller within 10 days of delivery. No other claims against Seller will be allowed unless asserted in writing within 60 days after delivery or, in the case of an alleged breach of warranty, within 30 days after the date within the warranty period on which the defect is or should have been discovered by Buyer. Any action based upon breach of this agreement or upon any other claim arising out of this sale (other than an action by Seller for any amount due to Seller from Buyer) must be commenced within thirteen months from the date of tender of delivery by Seller or, for a cause of action based upon an alleged breach of warranty, within thirteen months from the date within the warranty period on which the defect is or should have been discovered by Buyer.

6. LIMITATION OF LIABILITY. UPON NOTIFICATION, SELLER WILL, AT ITS OPTION, REPAIR OR REPLACE A DEFECTIVE PRODUCT, OR REFUND THE PURCHASE PRICE. IN NO EVENT SHALL SELLER BE LIABLE TO BUYER FOR ANY SPECIAL, INDIRECT, INCIDENTAL OR CONSEQUENTIAL DAMAGES ARISING OUT OF, OR AS THE RESULT OF, THE SALE, DELIVERY, NON-DELIVERY, SERVICING, USE OR LOSS OF USE OF THE PRODUCTS OR ANY PART THEREOF, OR FOR ANY CHARGES OR EXPENSES OF ANY NATURE INCURRED WITHOUT SELLER'S WRITTEN CONSENT, EVEN IF SELLER HAS BEEN NEGLIGENT, WHETHER IN CONTRACT, TORT OR OTHER LEGAL THEORY. IN NO EVENT SHALL SELLER'S LIABILITY UNDER ANY CLAIM MADE BY BUYER EXCEED THE PURCHASE PRICE OF THE PRODUCTS.

7. Contingencies. Seller shall not be liable for any default or delay in performance if caused by circumstances beyond the reasonable control of Seller.

8. User Responsibility. The user, through its own analysis and testing, is solely responsible for making the final selection of the system and Product and assuring that all performance, endurance, maintenance, safety and warning requirements of the application are met. The user must analyze all aspects of the application and follow applicable industry standards and Product information. If Seller provides Product or system options, the user is responsible for determining that such data and specifications are suitable and sufficient for all applications and reasonably foreseeable uses of the Products or systems.

9. Loss to Buyer's Property. Any designs, tools, patterns, materials, drawings, confidential information or equipment furnished by Buyer or any other items which become Buyer's property, may be considered obsolete and may be destroyed by Seller after two consecutive years have elapsed without Buyer placing an order for the items which are manufactured using such property. Seller shall not be responsible for any loss or damage to such property while it is in Seller's possession or control.

10. Special Tooling. A tooling charge may be imposed for any special tooling, including without limitation, dies, fixtures, molds and patterns, acquired to manufacture Products. Such special tooling shall be and remain Seller's property notwithstanding payment of any charges by Buyer. In no event will Buyer acquire any interest in apparatus belonging to Seller which is utilized in the manufacture of the Products, even if such apparatus has been specially converted or adapted for such manufacture and notwithstanding any charges paid by Buyer. Unless otherwise agreed, Seller shall have the right to alter, discard or otherwise dispose of any special tooling or other property in its sole discretion at any time.

11. Buyer's Obligation; Rights of Seller. To secure payment of all sums due or otherwise, Seller shall retain a security interest in the goods delivered and this agreement shall be deemed a Security Agreement under the Uniform Commercial Code. Buyer authorizes Seller as its attorney to execute and file on Buyer's behalf all documents Seller deems necessary to perfect its security interest. Seller shall have a security interest in, and lien upon, any property of Buyer in Seller's possession as security for the payment of any amounts owed to Seller by Buyer.

12. Improper Use and Indemnity. Buyer shall indemnify, defend, and hold Seller harmless from any claim, liability, damages, lawsuits, and costs (including attorney fees), whether for personal injury, property damage, patent, trademark or copyright infringement or any other claim, brought by or incurred by Buyer, Buyer's employees, or any other person, arising out of: (a) improper selection, improper application or other misuse of Products purchased by Buyer from Seller; (b) any act or omission, negligent or otherwise, of Buyer; (c) Seller's use of patterns, plans, drawings, or specifications furnished by Buyer to manufacture Product; or (d) Buyer's failure to comply with these terms and conditions. Seller shall not indemnify Buyer under any circumstance except as otherwise provided.

13. Cancellations and Changes. Orders shall not be subject to cancellation or change by Buyer for any reason, except with Seller's written consent and upon terms that will indemnify, defend and hold Seller harmless against all direct, incidental and consequential loss or damage. Seller may change product features, specifications, designs and availability with notice to Buyer.

14. Limitation on Assignment. Buyer may not assign its rights or obligations under this agreement without the prior written consent of Seller.

15. Entire Agreement. This agreement contains the entire agreement between the Buyer and Seller and constitutes the final, complete and exclusive expression of the terms of the agreement. All prior or contemporaneous written or oral agreements or negotiations with respect to the subject matter are herein merged.

16. Waiver and Severability. Failure to enforce any provision of this agreement will not waive that provision nor will any such failure prejudice Seller's right to enforce that provision in the future. Invalidation of any provision of this agreement by legislation or other rule of law shall not invalidate any other provision herein. The remaining provisions of this agreement will remain in full force and effect.

17. Termination. This agreement may be terminated by Seller for any reason and at any time by giving Buyer thirty (30) days written notice of termination. In addition, Seller may by written notice immediately terminate this agreement for the following: (a) Buyer commits a breach of any provision of this agreement (b) the appointment of a trustee, receiver or custodian for all or any part of Buyer's property (c) the filing of a petition for relief in bankruptcy of the other Party on its own behalf, or by a third party (d) an assignment for the benefit of creditors, or (e) the dissolution or liquidation of the Buyer.

18. Governing Law. This agreement and the sale and delivery of all Products hereunder shall be deemed to have taken place in and shall be governed and construed in accordance with the laws of the State of Ohio, as applicable to contracts executed and wholly performed therein and without regard to conflicts of laws principles. Buyer irrevocably agrees and consents to the exclusive jurisdiction and venue of the courts of Cuyahoga County, Ohio with respect to any dispute, controversy or claim arising out of or relating to this agreement. Disputes between the parties shall not be settled by arbitration unless, after a dispute has arisen, both parties expressly agree in writing to arbitrate the dispute.

19. Indemnity for Infringement of Intellectual Property Rights. Seller shall have no liability for infringement of any patents, trademarks, copyrights, trade dress, trade secrets or similar rights except as provided in this Section. Seller will defend and indemnify Buyer against allegations of infringement of U.S. patents, U.S. trademarks, copyrights, trade dress and trade secrets ("Intellectual Property Rights"). Seller will defend at its expense and will pay the cost of any settlement or damages awarded in an action brought against Buyer based on an allegation that a Product sold pursuant to this Agreement infringes the Intellectual Property Rights of a third party. Seller's obligation to defend and indemnify Buyer is contingent on Buyer notifying Seller within ten (10) days after Buyer becomes aware of such allegations of infringement, and Seller having sole control over the defense of any allegations or actions including all negotiations for settlement or compromise. If a Product is subject to a claim that it infringes the Intellectual Property Rights of a third party, Seller may, at its sole expense and option, procure for Buyer the right to continue using the Product, replace or modify the Product so as to make it noninfringing, or offer to accept return of the Product and return the purchase price less a reasonable allowance for depreciation. Notwithstanding the foregoing, Seller shall have no liability for claims of infringement based on information provided by Buyer, or directed to Products delivered hereunder for which the designs are specified in whole or part by Buyer, or infringements resulting from the modification, combination or use in a system of any Product sold hereunder. The foregoing provisions of this Section shall constitute Seller's sole and exclusive liability and Buyer's sole and exclusive remedy for infringement of Intellectual Property Rights.

20. Taxes. Unless otherwise indicated, all prices and charges are exclusive of excise, sales, use, property, occupational or like taxes which may be imposed by any taxing authority upon the manufacture, sale or delivery of Products.

21. Equal Opportunity Clause. For the performance of government contracts and where dollar value of the Products exceed \$10,000, the equal employment opportunity clauses in Executive Order 11246, VEVRRA, and 41 C.F.R. §§ 60-1.4(a), 60-741.5(a), and 60-250.4, are hereby incorporated.

Miller Fluid Power

500 South Wolf Road
Des Plaines, IL 60016 USA
Tel.: (847) 298-2400
Fax: (800) 892-1008
E-mail: MFPCyImktg@parker.com
Website: www.millerfluidpower.com

Miller Fluid Power

160 Chisholm Drive
Milton, Ontario
Canada L9T 3G9
Tel.: (905) 693-3000
Fax: (905) 876-1958

All specifications and information subject to
change without notice or prior obligation.

Catalog M0910-4
03/2011

