

LION
PRECISION

EDDY-CURRENT SENSORS

Position • Displacement | High Speed • High Resolution



An Eddy-Current Sensor System

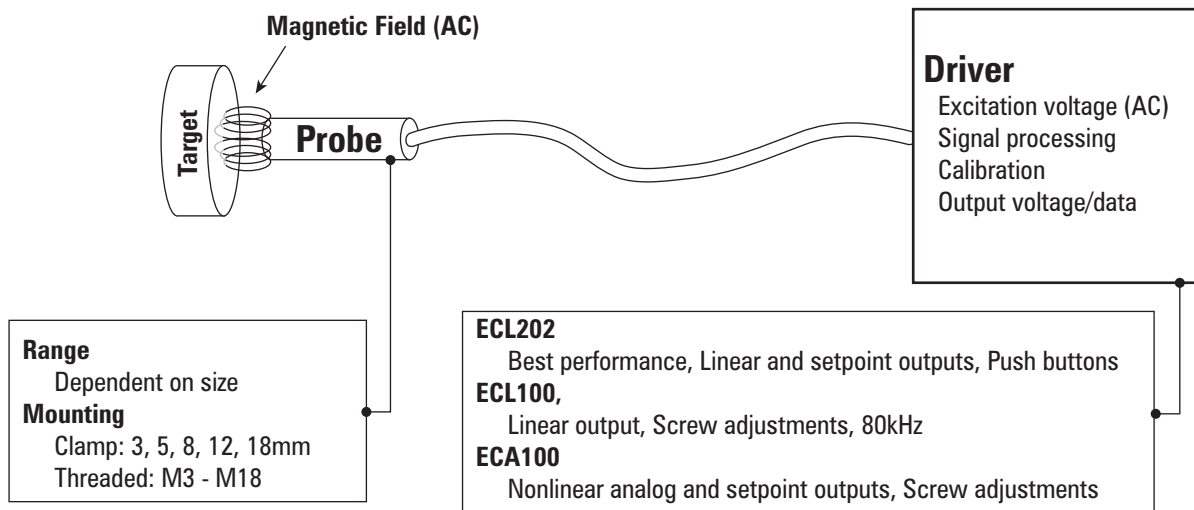

Eddy-Current Sensors

Basics

An eddy-current sensor produces an alternating magnetic field at the probe tip. When this field is near a conductive material, the field creates (induces) small electrical eddy-currents in the material. These currents generate a magnetic field that opposes the field from the sensor. As the gap between the probe and target gets smaller, the field interaction changes. The sensor electronics can measure this field interaction and generate an output voltage proportional to the change in the gap.

Conductive Targets

The eddy-currents induced in the target material are dependent on the specific material in use. As a result, eddy-current sensors are sensitive to changes in material. There can be a drastic difference between magnetic (iron, steel) and nonmagnetic (aluminum, copper) materials. Less drastic, but still significant, is the difference between two nonmagnetic materials. Material must be specified with orders to assure an accurate calibration. Because the magnetic fields penetrate the surface of the target, target materials have minimum thickness requirements. This varies with material type. TechNote LT02-0011, Minimum Recommended Target Thickness details the minimum target thickness for many materials. The TechNote is available at www.lionprecision.com; click on *Technical Library*.

Hostile Environments

The magnetic fields of eddy-current sensors cannot “see” nonconductive materials and therefore are not affected by most measurement area contaminants. This allows an eddy-current sensor to operate while immersed in liquids and in the presence of machine coolants or other liquid materials present in the sensing area.

Maximizing Accuracy

Accuracy at the high resolutions created by precision eddy-current sensors may be affected by the environment and measurement setup. Probes must be positioned in a stable mechanical system in a stable environment. Even small changes in temperature cause expansions of the target that are detectable by high-resolution sensors.

Resolution

Resolution is a measurement system’s smallest possible measurement. Resolution is essentially a measurement of electrical noise present at the sensor output. Eddy-current sensor resolution is a function of the bandwidth of the system. The lower the bandwidth, the better the resolution. When comparing specifications, *be sure to know the bandwidth at which the resolution is specified*.

Probes

- Probe identifiers begin with "U" and are created from the probe diameter (8mm, 12mm etc.) and the body style (A, B, C).
For example, a U8B probe is an 8mm probe with a "B" body style.
- All probes include a 3m cable. Custom lengths available at additional cost.
- Extension cables must be factory calibrated with the system.
- Probes are available in the following environmental ranges:
Standard: -25°C to 125°C, IP67
High-Temperature: -25°C to 200°C, IP63
- Vacuum compatible probes are available.

Custom probe design is common practice as we work with users to solve their measurement problems.

Ranges

Larger Probe = Larger Range
Custom ranges are available.

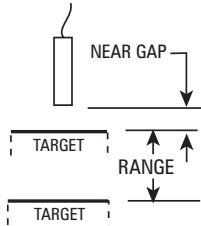

Probe	Range mm/inch	Near Gap mm/inch
U3	0.50/0.020	0.05/0.002
U5	1.25/0.050	0.25/0.010
U8	2.00/0.080	0.35/0.015
U12	3.50/0.140	0.60/0.025
U18	5.00/0.200	0.75/0.030
U25	8.00/0.320	1.25/0.050
U38	12.5/0.500	1.50/0.060
U50	15.0/0.600	2.00/0.080

Mounting

Probes must be mounted to avoid interaction between the sensing field and the mounting hardware. The area within 3 probe diameters to the sides and 1.5 diameters behind should be kept clear of any metallic objects other than the object to be measured.
If this is not possible, custom calibration may be required.

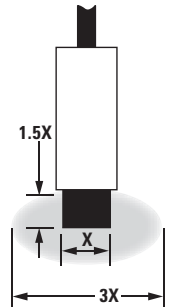

Body Styles and Mechanical Detail

A

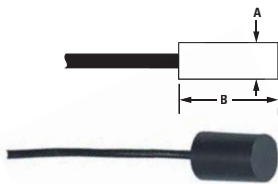

mm/inch	A	B
U5A	3.4 / 0.13	13.0 / 0.51
U8A	6.2 / 0.24	14.0 / 0.55
U12A	10.0 / 0.39	15.0 / 0.59
U18A	15.8 / 0.62	16.0 / 0.63

Core unit for smallest physical size. Gentle clamp mounting required.

B

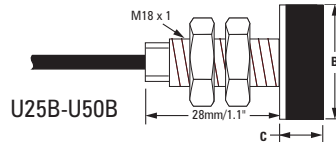
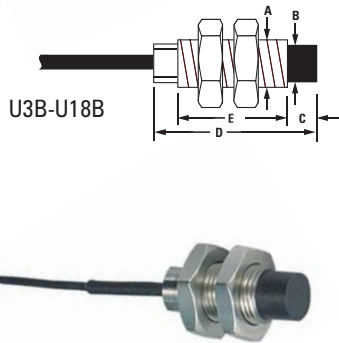

mm/inch	A	B	C	D	E	Wrench
U3B	M3x.5	2.0 / 0.08	3.0 / 0.12	21.1 / 0.83	13.0 / 0.51	5.5 / 0.22
U5B	M5x.8	3.4 / 0.13	3.0 / 0.12	25.0 / 0.99	18.0 / 0.71	8.0 / 0.31
U8B	M8x1	6.2 / 0.24	5.0 / 0.20	27.0 / 1.07	18.0 / 0.71	13.0 / 0.51
U12B	M12x1	10.0 / 0.39	7.0 / 0.28	29.0 / 1.15	18.0 / 0.71	17.0 / 0.67
U18B	M18x1	15.8 / 0.62	9.0 / 0.36	31.0 / 1.22	18.0 / 0.71	24.0 / 0.94
U25B		25.0 / 0.99	15.0 / 0.59			24.0 / 0.94
U38B		38.0 / 1.50	20.0 / 0.79			24.0 / 0.94
U50B		50.0 / 1.97	25.0 / 0.99			24.0 / 0.94

Threaded stainless steel body for threaded or thru-hole mounting.

C

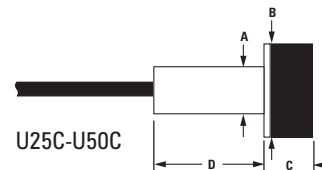
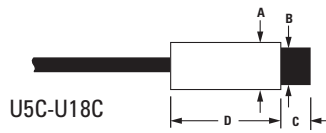
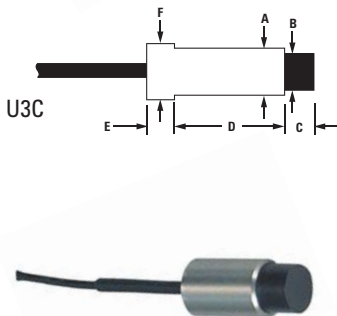

mm/inch	A	B	C	D	E	F
U3C	2.92 / 0.115	2.0 / 0.08	3.0 / 0.12	13.0 / 0.51	5.0 / 0.20	3.6 / 0.14
U5C	4.90 / 0.193	3.4 / 0.13	3.0 / 0.12	18.0 / 0.71		
U8C	7.90 / 0.311	6.2 / 0.24	5.0 / 0.20	18.0 / 0.71		
U12C	11.89 / 0.468	10.0 / 0.39	7.0 / 0.28	18.0 / 0.71		
U18C	17.91 / 0.705	15.8 / 0.62	9.0 / 0.36	18.0 / 0.71		
U25C	17.91 / 0.705	25.0 / 0.99	15.0 / 0.59	28.0 / 1.10		
U38C	17.91 / 0.705	38.0 / 1.50	20.0 / 0.79	28.0 / 1.10		
U50C	17.91 / 0.705	50.0 / 1.97	25.0 / 0.99	28.0 / 1.10		

Smooth stainless steel body for clamp or set-screw mounting.

Driver Comparison



Linear Analog Output	✓		✓
Nonlinear Analog Output		✓	
Setpoint (switched) Output	✓	✓	
Pushbutton Adjustments	✓		
Adjustable Gain (Span)		✓	✓
Adjustable Offset (Zero)	✓	✓	✓
Calibrated Range Indicator	✓	✓	✓
User-Selectable Bandwidth	100Hz, 1kHz, 10kHz, 15kHz		
Nonlinearity	0.2%	Nonlinear	0.25-0.5%
Resolution	0.002%–0.025%	0.02%	0.004%–0.06%
Maximum Bandwidth	15kHz	10kHz	80kHz

Options

Standard calibrations are for standard range probes with 3m cables and either Aluminum or 4140 steel targets. All options listed below require custom calibration.

- Nonstandard Ranges
- Nonstandard Material (Aluminum and 4140 Steel are standard)
- Nonflat target Shape
- Custom Cable length
- Probe Extension Cables (2m, 3m, 4m; must be calibrated and used with extension cable attached)
- Probe Vacuum Compatibility (to 10^{-6} Torr)
- Probe High-Vacuum Compatibility (below 10^{-6} Torr)

Accessories

High-Frequency, DIN rail mountable switching power supply



ECL100 Synchronization Kit (T-connectors and cables)



ECL202 - Top Performer



FPGA-Based digital system for easy setup and high performance

Performance

- Nonlinearity: $\pm 0.2\%$
- Resolution: $0.002\% - 0.025\%$ (see Range/Resolution table below)
- Bandwidth: 100Hz, 1kHz, 10kHz, 15kHz (user selectable)
- Low Phase Shift - Excellent for Servo Applications

Features

Easy Operation:

- Pushbutton Offset and Setpoint (Front Panel and Remote)
- Range Indicating LEDs
- Sync Multiple Units (factory shipped as single system)
- 15-24VDC Power

Multiple Outputs:

- 0-10VDC
- Setpoint Switch Contacts



Function Descriptions

Pushbutton Offset: Shifts the DC level of the output voltage to 5V (midscale) to establish repeatable reference point. Only functions when the probe is in the center 20% of its calibrated range.

Pushbutton Setpoint: Sets the setpoint voltage at which a contact closure output activates.

Specifications

Analog Output		0-10VDC, 0 Ω , 15 μ S update rate
Setpoint Switched Output	Maximum Voltage	30VAC/60VDC
	Maximum Current	100mA
	ON resistance	30-50 Ω
	OFF Leakage	1 μ A
	Hysteresis	0.1V
	Response Time	0.25mS On; 0.05mS Off
Input Power		15-24VDC, 2.5W
Remote Offset and Setpoint Inputs		15-24VDC to activate, 3-7mA
Driver Operating Environment		4°C to 50°C, IP40
Probe Operating Environment	Standard Probes	-25°C to 125°C, IP67
	High Temperature Probes	-25°C to 200°C, IP63

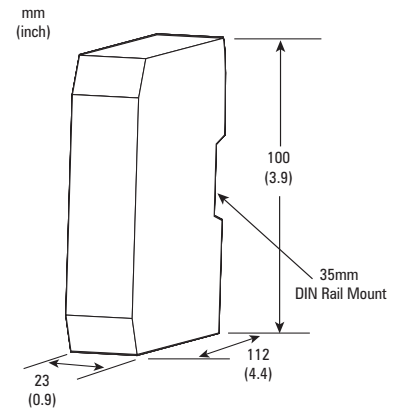

Range, Resolution, Thermal Drift

Specifications based on standard 3m cable and aluminum or 4140 steel targets.

Probe Model	Range mm/inch	Near Gap mm/inch	RMS Resolution ¹ nm/ μ inch								Thermal Drift ² %F.S./°C			
			Nonferrous				Ferrous				Nonferrous		Ferrous	
			100Hz	1kHz	10kHz	15kHz	100Hz	1kHz	10kHz	15kHz	Probe	Driver	Probe	Driver
U3	0.50/0.020	0.05/0.002	25/1.0	30/1.2	60/2.4	65/2.6	30/1.2	40/1.6	100/3.9	110/4.3	± 0.04	± 0.04	$\pm 0.04^3$	± 0.08
U5	1.25/0.050	0.25/0.010	45/1.8	65/2.6	140/5.5	150/5.9	80/3.1	120/4.7	240/9.4	260/10.2	± 0.04	± 0.1	± 0.1	± 0.1
U8	2.00/0.080	0.35/0.015	40/1.6	60/2.4	135/5.3	145/5.7	50/2.0	75/3.0	160/6.3	180/7.1	± 0.01	± 0.04	± 0.04	± 0.04
U12	3.50/0.140	0.60/0.025	60/2.4	90/3.5	210/8.3	240/9.4	100/3.9	170/6.7	340/13.4	390/15.4	± 0.02	± 0.04	± 0.03	± 0.04
U18	5.00/0.200	0.75/0.030	80/3.1	130/5.1	300/11.8	340/13.4	130/5.1	200/7.9	390/15.4	450/17.7	± 0.01	± 0.04	± 0.01	± 0.04
U25	8.00/0.320	1.25/0.050	180/7.1	270/10.6	600/23.6	650/25.6	220/8.7	310/12.2	650/25.6	750/29.5	± 0.01	± 0.04	± 0.01	± 0.04
U38	12.5/0.500	1.50/0.060	300/11.8	450/17.7	1000/39.4	1200/47.2	350/13.8	600/23.6	1100/43.3	1300/51.2	± 0.01	± 0.04	± 0.02	± 0.04
U50	15.0/0.600	2.00/0.080	320/12.6	550/21.7	1300/51.2	1400/55.1	370/14.6	670/26.4	1400/55.1	1500/59.1	± 0.01	± 0.04	± 0.01	± 0.04

¹ Peak-to-Peak resolution is approximately 10 X RMS resolution; in high EMI environments (10V/m), output noise levels could rise to 30mV RMS (0.3% resolution)

² Temperature coefficient specified at: Probe: 15°C - 65°C; Driver: 15°C - 50°C except where noted

³ Specified at limited temperature range for maximum performance, 15°C - 35°C

ECA100 - Basic Sensor



Lower cost sensor for repeatable measurements

Performance

- Nonlinearity: Nonlinear sensor, see chart below
- Resolution: 0.02% @ 10kHz¹
- Bandwidth: 10kHz

Features

Easy Operation:

- Adjustable Gain and Offset (Zero)
- Range Indicating LEDs
- Adjustable Setpoint
- 12-24VDC Power

Multiple Outputs:

- 0-10VDC
- Setpoint Switch Contacts



Function Descriptions

Gain: Adjusts the sensitivity (output voltage change per unit of target position change)

Offset (Zero): Shifts output DC level

Setpoint (Switch): Adjusts analog output voltage at which setpoint switch closure occurs

Specifications

Analog Output		0-10VDC, 0Ω
Probe Thermal Drift at Mid-Range		±0.2%FS/°C
Setpoint Switched Output	Maximum Voltage	30VAC/60VDC
	Maximum Current	100mA
	ON resistance	30-50Ω
	OFF Leakage	1μA
	Hysteresis	0.1V
	Response Time	0.25mS On; 0.05mS Off
Input Power		12-24VDC, 2W
Driver Operating Environment		4°C to 50°C, IP40
Probe Operating Environment	Standard Probes	-25°C to 125°C, IP67
	High Temperature Probes	-25°C to 200°C, IP63

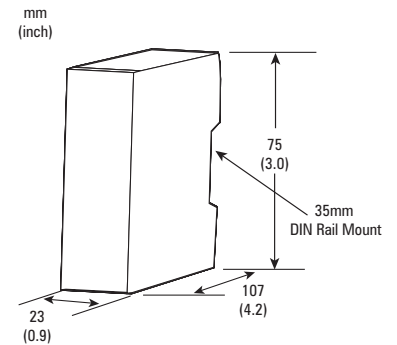

Ranges and Linearity

Probe Model	Range mm/inch	Near Gap mm/inch
U3	0.50/0.020	0.05/0.002
U5	1.25/0.050	0.25/0.010
U8	2.00/0.080	0.35/0.015
U12	3.50/0.140	0.60/0.025
U18	5.00/0.200	0.75/0.030
U25	8.00/0.320	1.25/0.050
U38	12.5/0.500	1.50/0.060
U50	15.0/0.600	2.00/0.080

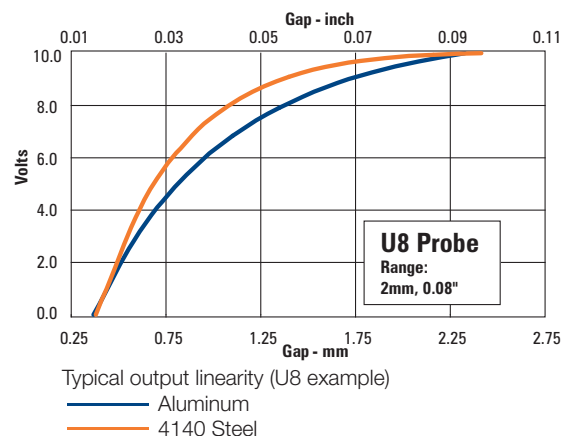

¹ RMS Resolution, Peak-to-Peak resolution is approximately 0.2%
In high EMI environments (10V/m), output noise levels could rise to 600mV RMS (6% resolution)

ECL100 - Wide Bandwidth Sensor



Linear, analog sensor with bandwidth to 80kHz

Performance

- Nonlinearity: $\pm 0.25\%$ (nonferrous), $\pm 0.50\%$ (ferrous)
- Resolution: 0.004%–0.06% (see Range/Resolution table below)
- Bandwidth: 1kHz, 10kHz, 80kHz (factory set)

Features

Easy Operation:

- Adjustable Offset (Front Panel and Remote)
- Range Indicating LEDs
- Sync Multiple Units (requires sync kit)
- 12-24VDC Power

Multiple Outputs:

- 0-10VDC
- 0-20mA



Function Descriptions

Offset (Zero): Shifts output DC level

Specifications

Analog Outputs		0-10VDC, 0 Ω 0-20mA
Probe Thermal Drift at Mid-Range		$\pm 0.04\%$ FS/ $^{\circ}$ C
Input Power		12-24VDC, 2W
Remote Offset (Zero)		± 10 VDC analog voltage
Driver Operating Environment		4 $^{\circ}$ C to 50 $^{\circ}$ C, IP40
Probe Operating Environment	Standard Probes	-25 $^{\circ}$ C to 125 $^{\circ}$ C, IP67
	High Temperature Probes	-25 $^{\circ}$ C to 200 $^{\circ}$ C, IP63

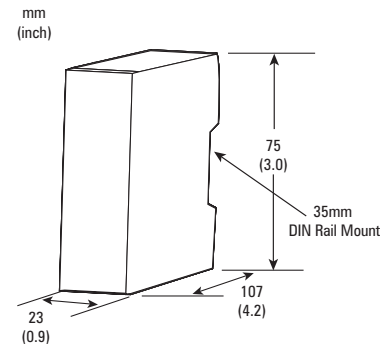

Range and Resolution

Specifications based on standard 3m cable and aluminum or 4140 steel targets.

Probe Model	Range mm/inch	Near Gap mm/inch	RMS Resolution ¹ nm/ μ inch					
			1kHz		10kHz		80kHz	
			Ferrous	Nonferr.	Ferrous	Nonferr.	Ferrous	Nonferr.
U3	0.50/0.020	0.05/0.002	40/1.6	30/1.2	80/3.1	60/2.4	300/12	200/7.9
U5	1.25/0.050	0.25/0.010	90/3.5	60/2.4	150/5.9	100/4.0	2000/79	250/9.8
U8	2.00/0.080	0.35/0.015	130/5.1	100/4.0	210/8.3	160/6.3	2000/79	1200/47
U12	3.50/0.140	0.60/0.025	260/10	200/7.9	350/14	280/11	1200/47	700/28
U18	5.00/0.200	0.75/0.030	320/13	240/9.4	640/25	480/19	4500/180	3200/130
U25	8.00/0.320	1.25/0.050	350/14		700/28		5300/210	
U38	12.5/0.500	1.50/0.060	550/22		1100/43		8300/330	
U50	15.0/0.600	2.00/0.080	660/26		1300/51		10000/390	

¹ Peak-to-Peak resolution is approximately 10 X RMS Resolution
In high EMI environments (10V/m), output noise levels could rise to 30mV RMS (0.3% resolution)

Typical Applications:

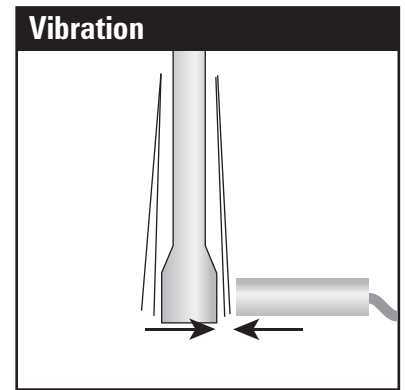
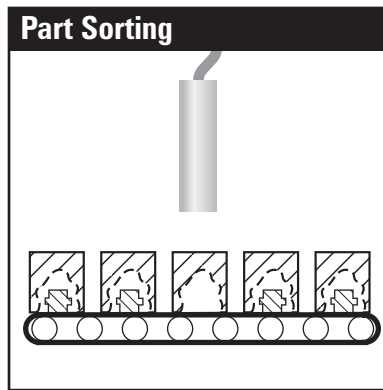
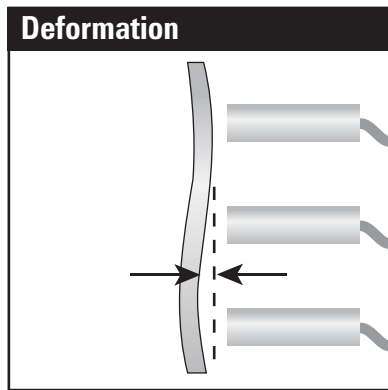
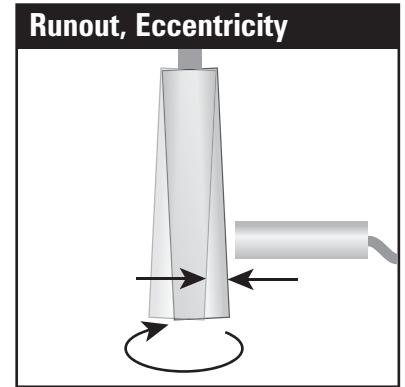
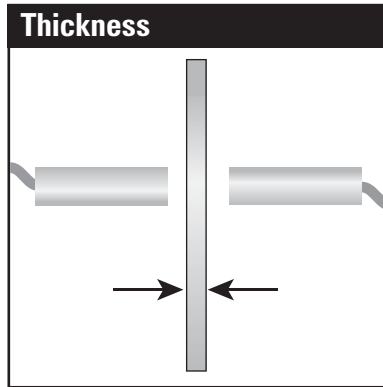
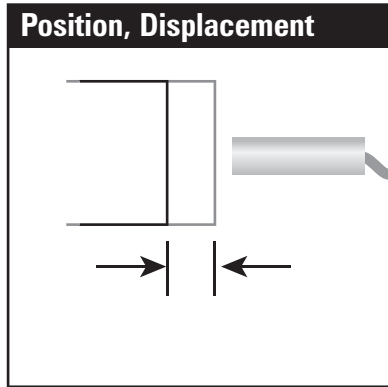

Commitment to Service

Lion Precision's commitment to service is unsurpassed in the industry. We partner with our customers to ensure their success by providing optimized sensing solutions. Contact us today and let us solve your difficult measurement problems.



563 Shoreview Park Rd.

St. Paul, MN 55126

www.lionprecision.com

phone 651-484-6544

fax 651-484-6824

info@lionprecision.com