



KOSHIN



KOSHIN

KOSHIN

KOSHINAMERICA.COM

KOSHIN AMERICA CORP.

KOSHIN AMERICA CORP.

1218 Remington Road
Schaumburg, IL 60173
(847) 884-1570 · (800) 634-4092
Fax (847) 310-0740
www.koshinamerica.com



*Automated Frame
Manufacturing*



Robotic Warehouse

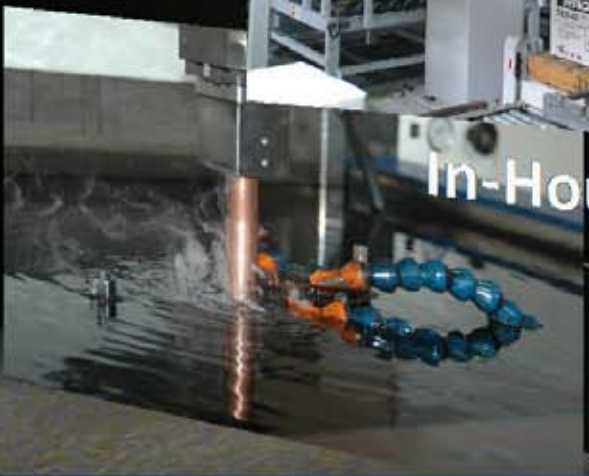

In-House Mold Factory



Headquarters (Kyoto, Japan)



KOSHIN Litian Pump (Ningbo)



KOSHIN (Thailand)

Design and specifications are subject to change without notice.

Die Cast Machining



Automated Powder Coating

KOSHIN MUSEUM



CENTRIFUGAL PUMPS	4
HIGH PRESSURE PUMPS	6
SEMI-TRASH PUMPS	7
TRASH PUMPS	8
SUBMERSIBLE PUMPS	10
DIAPHRAGM PUMPS	13
TRAILER MOUNTED TRASH PUMPS	14
GENERATORS	15

User Friendly Website
www.KOSHINAmerica.com



CENTRIFUGAL PUMPS

GASOLINE ENGINE DEWATERING PUMPS

Outstanding Features

- All impellers and volutes are constructed of cast iron for durability and long operating life, except SEH-25L and SEM-25E.
- Each pump casing is made of die cast aluminum for light weight, portability and strength.
- Each pump is protected from damage by sturdy, steel roll cage, except SEH-25L, SEM-25E, and SEH-40H. Vibration isolators are built-in.
- Low oil sensors are standard on Honda, Koshin, and Robin/Subaru engines, except SEH-25L.
- Self priming to 26 feet, maximum head up to 141 feet.



SEH-25L
HONDA ENGINE



SEM-25E
MITSUBISHI ENGINE



SEH-40H
HONDA ENGINE

Specifications

	SEH-25L	SEM-25E	SEH-40H	SEV-40R	SEH-50X	SE-50EX	SEV-50X	SEH-80X	SE-80EX	SEV-80X
Suction Discharge Size	1"NPT	1"NPT	1-1/2"NPT	1-1/2"NPT	2"NPT	2"NPT	2"NPT	3"NPT	3"NPT	3"NPT
Maximum Capacity	30 GPM	29 GPM	73 GPM	89 GPM	158 GPM	158 GPM	164 GPM	246 GPM	256 GPM	277 GPM
Maximum Head	106'	98'	141'	110'	98'	98'	82'	85'	102'	82'
Maximum Suction Lift	26'	26'	26'	26'	26'	26'	26'	26'	26'	26'
Maximum Pressure	47.2 PSI	43.7 PSI	61.0 PSI	51.0 PSI	42.4 PSI	42.4 PSI		36.8 PSI	44.2 PSI	
Engine Type	Honda GX25	Mitsubishi TLE20	Honda GX50	LTC 136	Honda GX120	Robin EX13	KOSHIN K180	Honda GX160	Robin EX17	KOSHIN K180
Displacement	25 cc	20 cc	49.4 cc	135 cc	118 cc	126 cc	179 cc	163 cc	169 cc	179 cc
Horsepower	1.0 HP	0.8 HP	2.2 HP	4.0 HP	3.5 HP	4.3 HP	6.0 HP	4.8 HP	5.7 HP	6.0 HP
Fuel Tank Capacity	0.15 Gal	0.12 Gal	0.051 Gal	0.72 Gal	0.66 Gal	0.71 Gal	0.95 Gal	0.95 Gal	0.95 Gal	.095 Gal
Continuous Operation Time Per Tank	1.2 Hrs	1.0 Hrs	.83 Hrs	2.5 Hrs	2.5 Hrs	2.0 Hrs	2.0 Hrs	2.5 Hrs	2.0 Hrs	1.6 Hrs
Fuel	Automobile non-lead gas	2 cycle mixed gas and oil	Unleaded Automotive Gasoline							
Dimension (LxWxH)	9"x4"x13"	9"x12"x13"	16"x13"x18"	20"x17"x17"	18"x14"x15"	19"x15"x17"	16"x20"x17"	20"x15"x18"	21"x16"x19"	21"x17"x19"
Dry Weight	12 Lb	11 Lb	25.3 Lb	53 Lb	48 Lb	53 Lb	58 Lb	68 Lb	67 Lb	70 Lb

Note: Performance ratings are guaranteed minimum, not inflated maximum.

CENTRIFUGAL PUMPS



SEH-80X



SE-80EX



SEH-50X



SEV-80X

Performance Curve

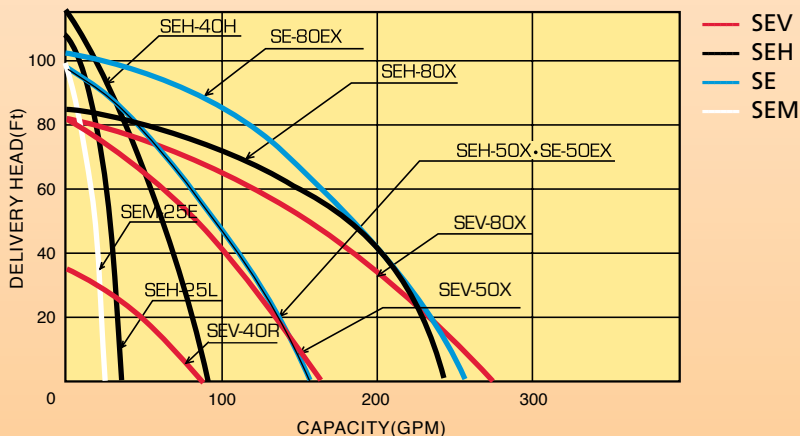

WK-12 Wheel Kit

12" Flat Free Tires
Expandable axle mounts to any Koshin pump frame



HIGH PRESSURE PUMPS

GASOLINE ENGINE HIGH PRESSURE PUMPS

Outstanding Features

- Powerful engines with low oil sensors.
- Light weight construction due to die cast aluminum casing.
- Full roll cage protects pump and engine with vibration isolators.
- Designed for sprinkling systems, fire fighting, agricultural use, and moving water long distances.

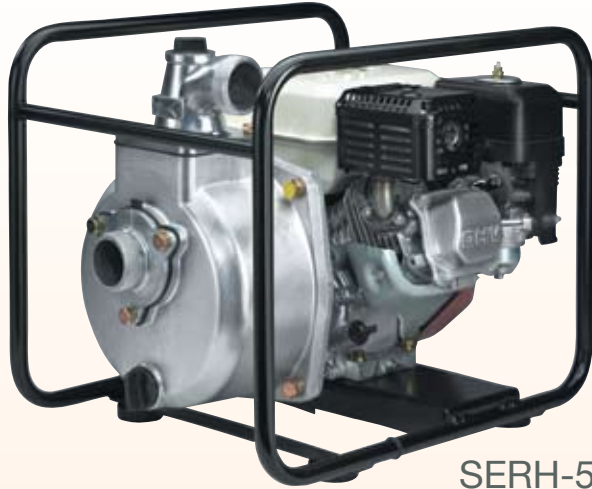

SERH-50B



SERM-50V

Performance Curve

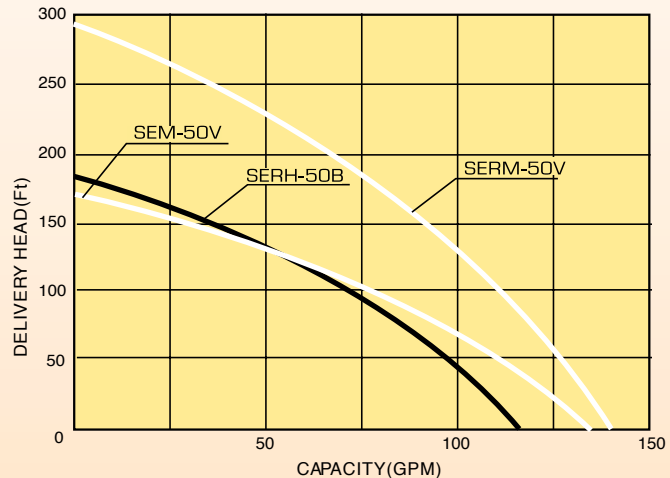

Specifications

	SERH-50B	SEM-50V	SERM-50V
Suction Discharge Size	2"NPT	2"NPT	2"/1"NPT
Maximum Capacity	116 GPM	132 GPM	132 GPM
Maximum Head	187'	164'	295'
Maximum Suction Lift	26'	26'	26'
Maximum Pressure	81.0 PSI	71.0 PSI	127.0 PSI
Engine Type	Honda GX160	Mitsubishi GM132	Mitsubishi GM182
Displacement	163 cc	126 cc	181 cc
Horse Power	4.8 HP	4.0 HP	6.0 HP
Fuel Tank Capacity	0.95 Gal	0.66 Gal	1.0 Gal
Continuous Operation Time Per Tank	2.0 HRS	2.0 HRS	2.0 HRS
Fuel	Unleaded Automotive Gasoline		
Dimension(LxWxH)	20"x15"x17"	20"x15"x17"	20"x17"x18"
Dry Weight	69 lb	55 lb	75 lb

Note: Performance ratings are guaranteed minimum, not inflated maximum.



SEM-50V

WK-12 Wheel Kit

12" Flat Free Tires
Expandable axle mounts to any Koshin pump frame



SEMI-TRASH PUMPS

GASOLINE ENGINE SEMI-TRASH PUMPS

Outstanding Features

- Powerful Honda and Koshin OHV engines with low oil sensors.
- Silicon carbide mechanical seals. Increased abrasive resistance, longer life, less maintenance.
- Impeller and volute manufactured from Spheroidal Graphite cast iron for longer life, less maintenance.
- Light weight die cast aluminum casing.
- Full roll cage protects pump and engine with vibration isolators.
- Strainer and wrench standard.



STV-80X



STH-50X

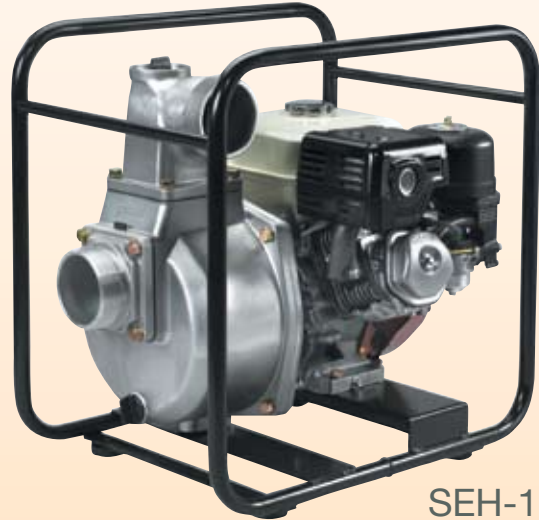

SEH-100T

Specifications

	STH-50X	STV-50X	STH-80X	STV-80X	SEH-100T
Suction Discharge Size	2"NPT	2"NPT	3"NPT	3"NPT	4"NPT
Maximum Capacity	158 GPM	164 GPM	238 GPM	277 GPM	383GPM
Maximum Head	95'	82'	85'	82'	92'
Maximum Suction Lift	26'	26'	26'	26'	26'
Maximum Pressure	41.1 PSI	35.5 PSI	36.8 PSI	35.5 PSI	39.8 PSI
Engine Type	Honda GX120	KOSHIN K180	Honda GX160	KOSHIN K180	Honda GX240
Displacement	118 cc	180 cc	163 cc	180 cc	242 cc
Horsepower	3.5 HP	6.0 HP	4.8 HP	6.0 HP	7.1HP
Fuel Tank Capacity	0.86 Gal	0.95 Gal	0.95 Gal	0.95 Gal	1.58 Gal
Continuous Operation Time Per Tank	2.5 Hrs	2.0 Hrs	2.5 Hrs	1.6 Hrs	2.5 Hrs
Fuel	Unleaded Automotive Gasoline				
Dimension (LxWxH)	18"x14"x15"	16"x20"x17"	20"x15"x17"	21"x17"x19"	26"x26"x20"
Dry Weight	56 Lb	58 Lb	75 Lb	70 Lb	135 Lb

Performance Curve

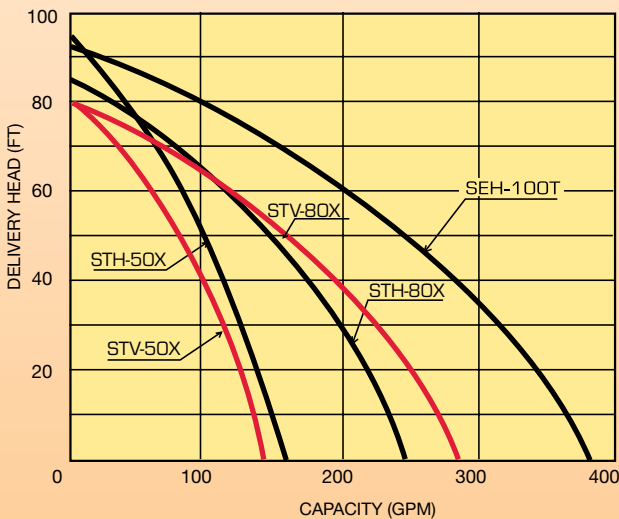

Note: Performance ratings are guaranteed minimum, not inflated maximum.



TRASH PUMPS

GASOLINE ENGINE



KTH-50X



KTH-80X

Outstanding Features

- The clean-out cover and volute can be easily removed in seconds for easy cleaning of debris.
- Silicon carbide mechanical seals. Increased abrasive resistance, longer life, less maintenance.
- Impeller is Hi-chrome cast iron. Volute manufactured from Spheroidal Graphite cast iron. These materials employed to ensure long life and low maintenance. Wear plates are not necessary.
- Sturdy steel wrap-around pipe frame protects entire unit. Rubber mountings minimize vibration.
- Honda OHV engines with oil sensors and electronic ignition provides reliability and low fuel consumption.
- Multi-tool spanner wrench standard.

Performance Curve

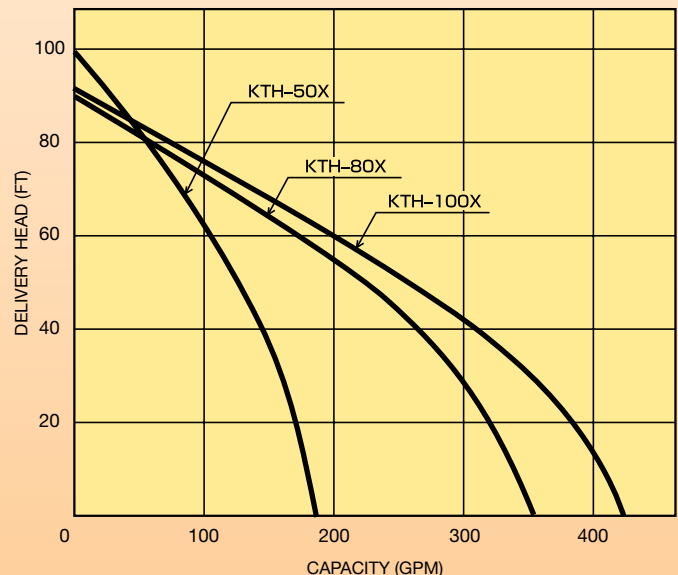

TRASH PUMPS

TRASH PUMPS

WK-12 Wheel Kit

12" Flat Free Tires
Expandable axle
mounts to any
Koshin pump frame



KTH-100X

Specifications

	KTH-50X	KTH-80X	KTH-100X
Suction Discharge Size	2"NPT	3"NPT	4"NPT
Maximum Capacity	185 GPM	354 GPM	422 GPM
Maximum Head	98'	89'	82'
Maximum Suction Lift	26'	26'	26'
Maximum Pressure	42.4 PSI	38.5 PSI	35.5 PSI
Engine Type	Honda GX160	Honda GX240	Honda GX340
Displacement	163 cc	242 cc	337 cc
Horse Power	4.8 HP	7.1 HP	9.5 HP
Fuel Tank Capacity	0.95 Gal	1.58 Gal	1.72 Gal
Continuous Operation Time Per Tank	2.0 HRS	2.0 HRS	1.5 HRS
Fuel	Unleaded Automotive Gasoline		
Dimension(LxWxH)	24"x18"x19"	27"x19"x22"	30"x28"x28"
Dry Weight	93 lb	128 lb	172 lb

Note: Performance ratings are guaranteed minimum, not inflated maximum.

Special Material for Koshin Trash Pumps

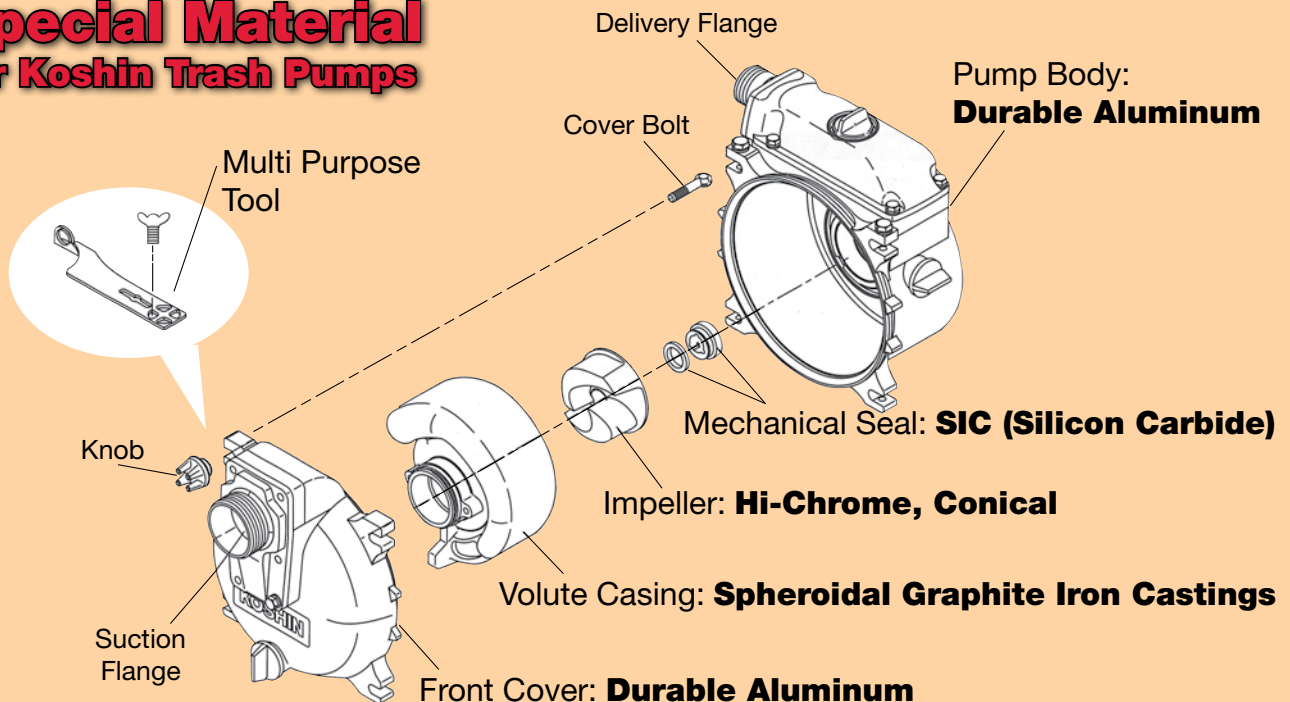



SUBMERSIBLE PUMPS

GENERAL DEWATERING SUBMERSIBLE PUMPS

Outstanding Features

- Compact, light weight, easy to carry and handle.
- Double mechanical seals run in an “oil” filled chamber of liquid paraffin to prevent damage from periods of dry running.
- The built-in thermal protector turns off the power supply in case of overload, thereby protecting the motor.
- The power cord is uni-body construction ensuring excellent water tightness.
- Liquid is channeled through the outer wall to cool the motor for maximum endurance on PB and PX models.
- PX model impeller and casing are manufactured from a blended rubber compound providing maximum wear resistance up to 3 times over cast iron.
- PX, PXL model design permits vertical or horizontal discharge.



PX-65011

Triple life span due to special rubberized impeller as compared with cast iron impeller.

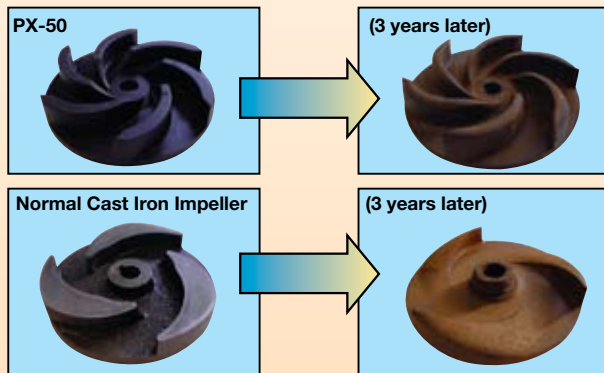

Change delivery flange direction and delivery hose will never be bent again.

Specifications

	PX-65011	PS-65011	PB-65011	PB7-65011	PB-68011
Suction Discharge Size	2"NPT	2"NPT	2"NPT	2"NPT	3"NPT
Maximum Capacity	4110 GPH	4600 GPH	4600 GPH	5520 GPH	7286 GPH
Maximum Head	33'	33'	33'	59'	61'
Motor Output	1/2 HP	1/2 HP	1/2 HP	1.0 HP	2.0 HP
Voltage	AC-110V	AC-110V	AC-110V	AC-110V	AC-110V / 220V
Rated Current	6.5 AMP	7.2 AMP	7.2 AMP	10.9 AMP	15 AMP
Cable Length	20'	20'	20'	32'	40'
Width	7-1/4"	9-1/2"	7-1/2"	7-1/2"	9-1/2"
Height	12-1/2"	14-1/2"	17"	17"	25"
Dry Weight	24 lb	29 lb	36 lb	42 lb	80 lb

Note: Performance ratings are guaranteed minimum, not inflated maximum.

SUBMERSIBLE PUMPS



PB-65011



PB7-65011



PS-65011



PB-68011

Performance Curve

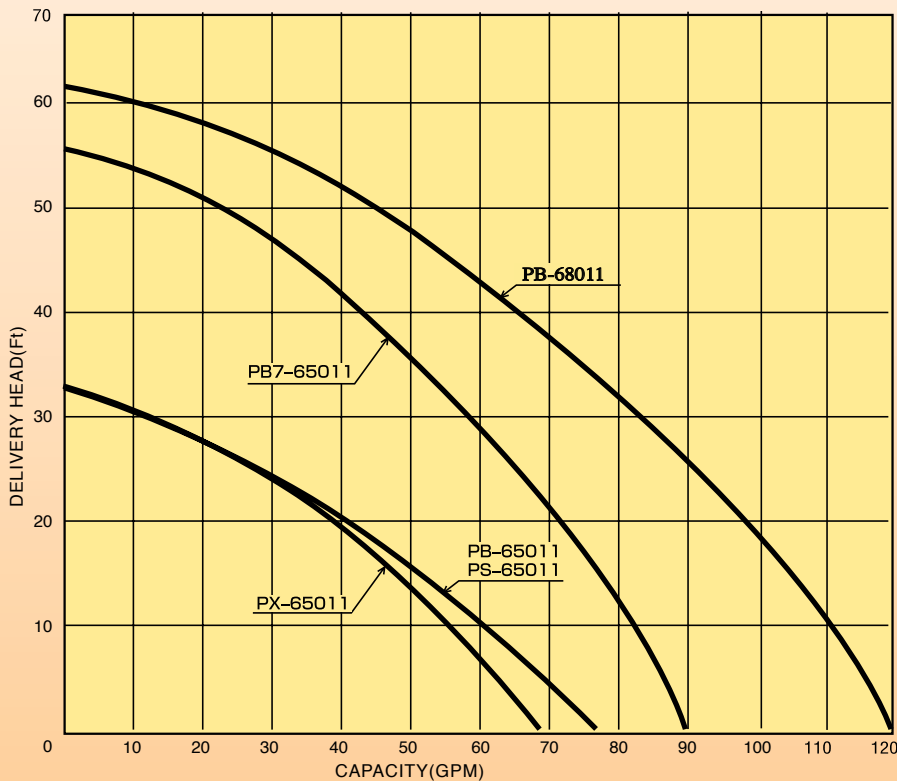

FLOAT SWITCH (optional)

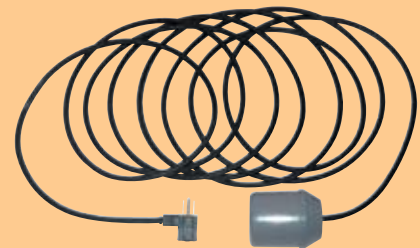

- A float switch can control your submersible pump's operation automatically.
- "Piggy-backed" connections for ease of operation and installation.
 FS-10
 FS-20 (For PB7-65011 only)
 FS-30 (For PB-68011 only)



SUBMERSIBLE PUMPS

BOTTOM SUCTION SUBMERSIBLE PUMP

Outstanding Features

- Pumps down to within 1mm or 0.04" of floor level.
- Built-in check valve keeps liquid in pump and hose eliminating any "back-flow" situations.
- Liquid is channeled through the outer wall to cool the motor for maximum endurance.
- Impeller and casing are manufactured from a blended rubber compound providing maximum wear resistance.
- Double mechanical seals run in an "oil" filled chamber of liquid paraffin to prevent damage from periods of dry running.
- The built-in thermal protector turns off the power supply in case of overload, thereby protecting the motor.



PXL-65011

SUBMERSIBLE TRASH PUMP

Outstanding Features

- This unique pump easily handles leaves, sewage and solids up to 5/8" diameter.
- Cleanout is fast and easy by means of three butterfly bolts.
- It is compact, light-weight, easy to carry and handle.
- Double mechanical seals run in an "oil" filled chamber of liquid paraffin to prevent damage from periods of dry running.
- The built-in thermal protector turns off the power supply in case of overload, thereby protecting the motor.
- The power cord is uni-body construction ensuring excellent water tightness.



PKS-65011

SUBMERSIBLE UTILITY PUMPS

Outstanding Features

- These pumps have lightweight ABS plastic bodies and bases for corrosion resistance.
- Metal motor housing for cool running.
- Oil filled mechanical seal allows for periods of dry running without damage.
- Completely rebuildable. All parts are replaceable.
- 3/4" garden hose adapters standard.



NSM-62011

Specifications

	PKS-65011	PXL-65011	NMS-62011
Suction Discharge Size	2"NPT	3/4", 2"NPT	3/4"NPT
Maximum Capacity	4760 GPH	1500 GPH	800 GPH
Maximum Head	33'	36'	16.5'
Motor Output	1/2 HP	1/2 HP	1/6 HP
Voltage	AC-110V	AC-110V	AC-110V
Rated Current	7.0 AMP	6.4 AMP	1.5 AMP
Cable Length	20'	20'	13.5'
Width	10"	7.25"	5"
Height	16.5"	12.5"	9.125"
Dry Weight	33 lb	26 lb	6.5 lb

Performance Curve

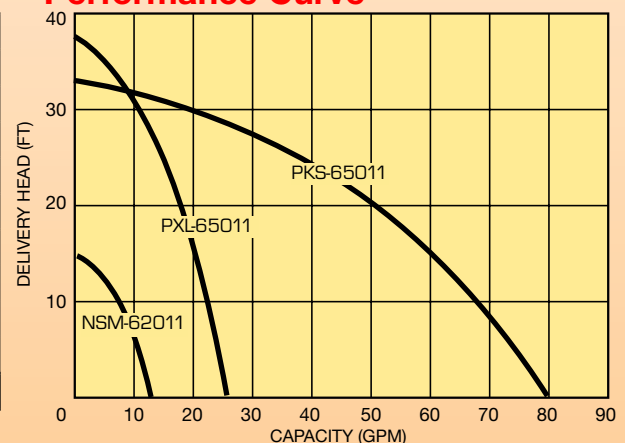

Note: Performance ratings are guaranteed minimum, not inflated maximum.

DIAPHRAGM PUMPS

GASOLINE ENGINE DIAPHRAGM PUMP

Outstanding Features

- All feature quiet and reliable Honda 4 HP overhead valve engines with a “low oil” sensor.
- Straight line flow design is self cleaning; eliminates clogging.
- Pump housings are made of light weight cast aluminum.
- Standard wheel kits provide portability.
- Pumps are built to run dry without damage; perfect for areas of slow seepage.
- Oil-filled gear reduction means quiet operation.

Specifications

	KDP-50X	KDP-80XW
Connection Diameter	2" NPT	3" NPT
Delivery Volume	3120 GPH	5280 GPH
Maximum Head	25'	25'
Engine Type	GX120KIHX	GX120KIHX
Horsepower	3.5 HP	3.5 HP
Fuel	Gasoline	Gasoline
Fuel Tank Capacity	.66 Gal.	.66 Gal.
Starting	Recoil Starter	Recoil Starter
Net Weight	168 lb.	176 lb.

Note: Pumps should not be operated with a positive suction head.

Warning: Do not use in explosive atmosphere or for pumping volatile flammable liquids.



Performance Curves

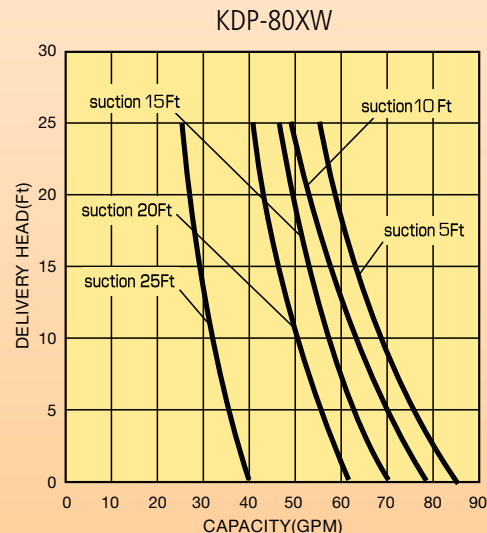
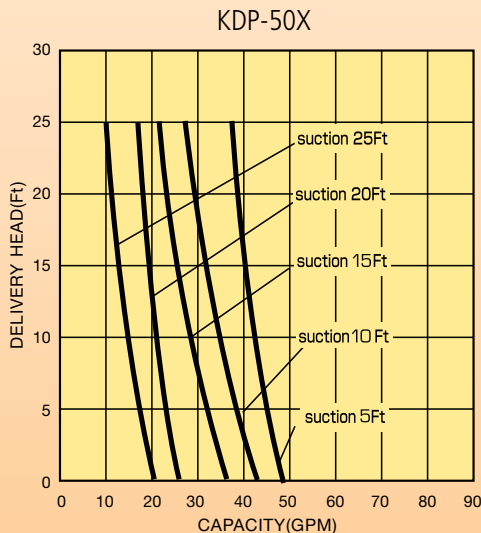



TRAILER MOUNTED TRASH PUMPS

6" TRASH PUMP

Outstanding Features

- Cast aluminum casing and adapter
- Cast iron seal plate, volute and manifold
- Stainless steel impeller
- Silicon carbide mechanical seal and Buna O-rings and flapper/check valve
- Handles up to 3" spherical solids
- Easy cleanout and service features with unique slide mechanism permits complete service of pump without removing hoses or removing pump components from trailer (patent pending)
- 12 VDC electric start. Digital tachometer/hourmeter included
- D.O.T. approved trailer. (See your state and local codes for registration)
- Low oil alert, gasoline model
- Maximum temperature 180°F
- Includes tools with open end and hex wrench sets for servicing pump



KTD-150
KTH-150

Specifications

	KTD-150	KTH-150
Suction Discharge Size	6"NPT	6"NPT
Maximum Capacity	1000 GPM	1000 GPM
Maximum Head	98'	98'
Maximum Suction Lift	26'	26'
Maximum Pressure	40 PSI	40 PSI
Engine Type	Yanmar	Honda V-Twin OHV
Displacement	904 cc	670 cc
Horsepower	23 HP	24 HP
Fuel Tank Capacity	20 Gal	12 Gal
Continuous Operation Time Per Tank	12 Hrs	6 Hrs
Fuel	Automobile Diesel	Unleaded Automotive Gasoline
Dimension (LxWxH)	92"x52"x48"	92"x52"x48"
Dry Weight	1125 Lb	800 Lb

Performance

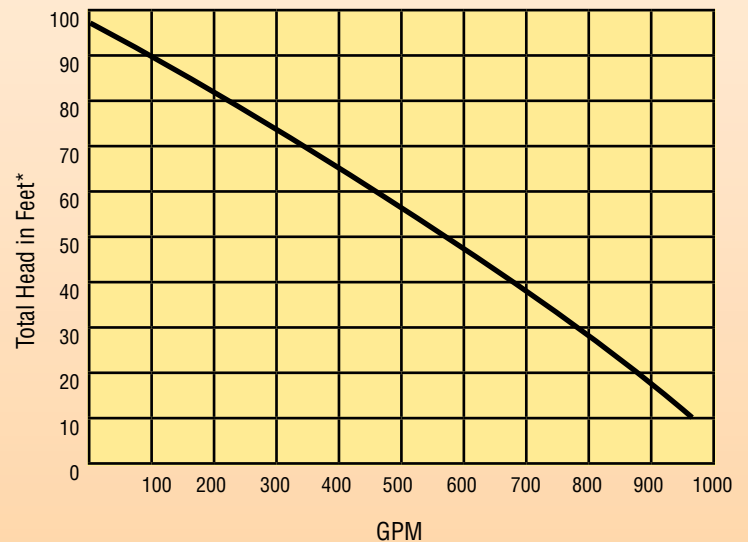

Capacity in US Gallons Per Minute @ 3600 RPM
*Convert to PSI, divide by 2.31

Note: Performance ratings are guaranteed minimum, not inflated maximum.



KOSHIN GENERATORS

INTRODUCING A PROFESSIONAL LINE OF GENERATORS

Outstanding Features

- Extended run fuel tank with easy access fuel valve
- Full roll cage for ultimate protection
- Premium quiet package
- Hydraulic/Magnetic circuit breakers
- Easy-to-read control panel
- Premium brushless alternator
- Idle control
- Wheel Kit available
- Honda engine with low oil alert
- Backed by KOSHIN

Benefits

- Longer run times, less maintenance, fuel efficient
- Job site and transportation protection. No lifting eye required
- 75 dba, low tone exhaust, quieter operation
- Reliable, superior overload protection
- UL/CSA/OSHA compliant
- Less than 5% harmonic distortion
- Job site portability
- EPA, CARE and CSA compliant
- 3-year warranty

Specifications

	GEH-3100DX	GEH-4000DX	GEH-6000DX	GEH-7200EX	GEH-14000EW
RATED POWER (WATTS)	2600	3800	5300	6100	11700
SURGE POWER (WATTS)	3100	4000	6000	7200	14000
VOLTAGE	120	120 / 240	120 / 240	120 / 240	120 / 240
AMPS @ 120 VAC	25.8	31.6	44.2	50.8	97.5
AMPS @ 240 VAC		15.8	21.1	25.4	48.7
ENGINE	HONDA GX160	HONDA GX240	HONDA GX340	HONDA GX390	HONDA GX630
START SYSTEM	RECOIL	Recoil	Recoil	Electric* Recoil	Electric*
FULL LOAD RUN TIME (HOURS)	7.1	12.4	10.4	9.2	6.5
FUEL TANK (GAL)	2.91	7	8	8	8
DIMENSIONS (IN) L x W x H	23 x 17 x 18	30 x 23 x 26	32 x 23 x 27	32 x 23 x 27	39 x 23 x 32
WEIGHT (LBS)	88	161	189	200	316
WHEEL KIT- WKG-10	Optional	Optional	Optional	Optional	Standard
RECEPTACLES	NEMA 5-20R 125V GFCI	2-NEMA 5-20R 125V GFCI NEMA L5-30R 125V T/L NEMA L14-20R 125-250V T/L	2-NEMA 5-20R 125V GFCI NEMA L5-30R 125V T/L NEMA L14-30R 125-250V T/L	2-NEMA 5-20R 125V GFCI NEMA L5-30R 125V T/L NEMA L14-30R 125-250V T/L	2-NEMA 5-20R 125V GFCI NEMA L14-30R 125-250V T/L NEMA L14-50R 125-250V T/L

*Recommended Battery — Sealed 12V 18 amp

INDUSTRIAL RELIABILITY



GEH-4000DX



GEH-6000DX



Wheel Kit Available standard on GEH-14000EW



GEH-14000EW

KOSHIN AMERICA CORP.

1218 Remington Road

Schaumburg, IL 60173

(847) 884-1570 · (800) 634-4092

Fax (847) 310-0740

www.koshinamerica.com



Design and specifications are subject to change without notice.