

Jewell Instruments

Sensors

Accelerometers
Inclinometers
Custom Solutions



DECADES OF EXPERIENCE
In Precision Sensors

Highly Accurate Sensing Solutions

With over forty years' experience, Jewell Instruments is a world leader in the manufacture and distribution of inertial sensors, including accelerometers and inclinometers. Well-known for both quality and reliability, Jewell sensors are available for a wide range of industrial, commercial, and aerospace applications.

What makes us unique is our ability to create cost-effective custom solutions based on a foundation of experience and expertise built over the past four decades. Our products start where others leave off.

Our high-accuracy sensors feature:

- $\pm 1.0^\circ$ to $\pm 90^\circ$ and $\pm 0.01g$ to $\pm 20g$, full range
- $< 0.02\%$ nonlinearity
- high level ± 5 volt output
- less than 0.0001 volt noise
- $< 0.001\%$ repeatability and hysteresis
- μ radian resolution and dc response

Applications include:

Aircraft

Autopilot
Angle of Attack
Stall Warning
Fatigue Monitoring
Flight Testing
Attitude Heading & Reference



Missile

Autopilot
Stage Separation
Thrust Measurement
Safety & Monitoring
Destruct Decision



Marine

Ship Attitude Control
Offshore Platform
Leveling & Control
Remote Submersible Control
Sea State Monitoring
Barge Leveling
Test Instrumentation



Tilt Sensing

Antenna Leveling & Control
Fire Control
Missile Erecting
Torpedo Attitude Control
Platform Stabilizing
Land Navigation



Industrial

Automotive Performance Testing
Elevator Control
Seismic Monitoring
Oil & Gas Well Logging
Land Surveying
Antenna Leveling
Dam Monitoring
Machine Tool Motion Control



Rail

Railbed Monitoring
Car Tilt Control
Acceleration &
Deceleration Control
Performance Testing



Accelerometers

All Jewell accelerometers are fully self-contained. They connect to a DC power source and a readout or control device for a complete operating system. The output is a high-level DC signal proportional to acceleration and tilt angle sine from as little as ± 0.010 g to ± 20 g full range. Jewell accelerometers respond to change in velocity as small as $1 \mu\text{g}$. Hysteresis less than 0.0005% of full range output and vibration rectification less than $50 \mu\text{g}/\text{G}^2$ are available.



LCM Series

A general purpose tilt sensor for industrial, commercial, and aerospace applications. Engineered with micromachined components, the LCM offers an attractive price/performance ratio. This 0.5g to 5g device meets the demanding needs of applications requiring 500g shock resistance and up to 500Hz bandwidth.



LSM Series

The LSM Series offers features equivalent to the LCA, but in a smaller package, approximately 1" cube. Its smaller size and wide bandwidth and range make it ideal for many aerospace applications.



LCA Series

A 0.5g to 5g full scale acceleration sensing device with pivot and jewel suspension technology and 60Hz-250Hz bandwidth make the LCA-100 popular for a variety of military, commercial, and aerospace sensing applications.



LCF Series

The most rugged of all our accelerometers, the LCF-200 is a compact, highly accurate, high-performance sensor with a range of 0.50g to 5g full scale; ideal for many military and rugged commercial uses. Internal electronics options feature single-ended self-test and a 2-pole output noise suppression filter.

	LCF-200			LCA-100			LSM						LCM-100		
Performance															
Input Range, g:	± 0.5	± 2.0	± 5.0	± 0.5	± 2.0	± 5.0	± 0.5	± 1.0	± 2.0	± 5.0	± 10.0	± 20.0	± 0.5	± 2.0	± 5.0
Full Range Output (FRO), volts $\pm 1\%$¹:	± 5.0	± 5.0	± 5.0	± 5.0	± 5.0	± 5.0	± 5.0	± 5.0	± 5.0	± 5.0	± 5.0	± 5.0	± 5.0	± 5.0	± 5.0
Nonlinearity, % FRO²:	0.05	0.05	0.05	0.05	0.05	0.05	0.05	0.05	0.05	0.10	0.10	0.25	0.20	0.20	0.20
Scale Factor, volts/g, nominal:	10.0	2.50	1.00	10.0	2.50	1.00	10.0	5.0	2.5	1.0	0.5	0.25	10.0	2.5	1.0
Scale Factor Temp Sens, PPM/$^{\circ}\text{C}$ max:	100	100	100	180	180	180	200	200	200	200	200	200	0.50% reading over the temp. range		
Bias, g, maximum:	0.005	0.005	0.005	0.01	0.01	0.01	0.050	0.010	0.010	0.010	0.020	0.050	0.05	0.10	0.10
Bias Temperature Sensitivity, $\mu\text{g}/^{\circ}\text{C}$, max:	50	50	50	100	100	100	50	50	50	100	100	200	0.03g/ $^{\circ}\text{C}$	0.03g/ $^{\circ}\text{C}$	0.03g/ $^{\circ}\text{C}$
Natural Frequency, Hz, nominal³:	30	30	30	60	60	60	70	100	140	100	140	160	60	60	60
Bandwidth (-3db), Hz, nominal:	30	30	30	60	60	60	70	100	140	100	140	160	60	60	60
Transverse Axis Misalignment, $^{\circ}$ max:	1.0	1.0	1.0	1.0	1.0	1.0	1	1	1	1	1	1	3.0	3.0	3.0
Resolution and Threshold, μg max:	10	10	10	100	100	100	10	10	10	10	20	50	0.005g	0.005g	0.005g
Electrical															
Input Voltage, VDC:	± 12 to ± 18			± 12 to ± 18			± 12 to ± 18						± 12 to ± 18		
Input Current, mA, nominal:	15			25			10						15		
Output Impedance, ohms, nominal:	100			100			10.0k	5.0k	2.5k	5.0k	2.5k	2.5k	100		
Noise, V_{rms}, maximum:	0.002			0.005			0.005						0.020 0.010 0.010		
Environmental															
Operating Temp Range:	-40°C to $+80^{\circ}\text{C}$			-55°C to $+85^{\circ}\text{C}$			-55°C to $+85^{\circ}\text{C}$						-40°C to $+85^{\circ}\text{C}$		
Survival Temp Range:	-60°C to $+90^{\circ}\text{C}$			-65°C to $+90^{\circ}\text{C}$			-65°C to $+105^{\circ}\text{C}$						-65°C to $+85^{\circ}\text{C}$		
Shock:	1000g, 1msec, 1/2 sine			100g, 11msec, 1/2 sine			100g, 11msec, 1/2 sine						500g, 0.5msec, 1/2 sine		
Vibration:	20 grms			5 grms			5 grms						10 grms		
Seal:	Epoxy			Epoxy			Epoxy						Epoxy		
Weight:	5oz.			4oz.			2 oz.						4 oz.		

¹ Full Range is defined "from negative full input acceleration to positive full input acceleration."
² Nonlinearity is specified as deviation of output referenced to theoretical input function value, independent of misalignment.
³ Output Phase angle = -90° .

Inclinometers

Jewell inclinometers are extremely sensitive, rugged transducers designed to provide horizontal angle or vertical deviation measurements with virtually infinite resolution. Every inclinometer responds to changes of slope as small as 0.1 second of arc, with a high-level DC output signal proportional to the sine of the angle of tilt from as little as $\pm 1^\circ$ full range to $\pm 90^\circ$ full range.



LCI Series

Ideal for low frequency laboratory applications, the LCI Series is highly accurate, featuring a torsion flexure suspension that offers superior repeatability and low hysteresis.



LSO Series

Our most rugged, general-purpose, all-weather inclinometers are well-suited for a variety of commercial and industrial applications. Each casing is machined from solid aluminum.



LCF Series

Suitable for high-accuracy applications with high levels of shock and vibration, the LCF-100 Series uses a fluid-damped torsion flexure suspension that attenuates input energy to provide accuracy at low frequencies, even when subjected to high frequency shock and vibration.



LSR Series

Its compact, cylindrical shape and stackability enable several inclinometers to be used when multi-axis measuring is required. The LSR offers the same precise measurements with high outputs at lower range frequencies as our LSO Series.

	LSO / LSR					LCI			LCF-100			
Performance												
Input Range, °:	±1	±3	±14.5	±30	±90	±14.5	±30	±90	±1.0	±14.5	±30	±90
Full Range Output (FRO), volts ±1%:	±5.0	±5.0	±5.0	±5.0	±5.0	±5.0	±5.0	±5.0	±5.0	±5.0	±5.0	±5.0
Nonlinearity, % FRO ² max:	0.05	0.05	0.02	0.02	0.05	0.02	0.02	0.05	0.05	0.02	0.02	0.05
Scale Factor, volts/g, nominal:	286.5	95.5	20.0	10.0	5.0	20.0	10	5.0	286.5	20.0	10.0	5.0
Scale Factor Temp Sens, PPM/°C max:	400	300	100	60	60	100	100	100	100	100	100	100
Natural Frequency, Hz, nominal ³ :	0.5	2.0	15.0	20.0	40.0	5	5	5	3	30	30	30
Bandwidth (-3db), Hz, nominal:	0.5	2.0	15.0	20.0	40.0	5	5	5	3	30	30	30
Transverse Axis Misalignment, ° max:	0.1	0.15	0.25	0.5	1.0	0.5	1.0	1.0	0.15	0.5	1.00	1.00
Output at 0° Tilt, volts, maximum:	0.1	0.04	0.02	0.02	0.02							
0° Output Temp Sensitivity, volts/°C, max:	0.005	0.003	0.001	0.0005	0.0003							
Bias, volts max:						0.050	0.050	0.025	0.500	0.100	0.100	0.050
Bias Temp Sensitivity, volts/°C max:						0.0005	0.0005	0.0003	0.015	0.001	0.0005	0.0003
Resolution and Threshold, μradian:	1	1	1	1	1	1	1	1	1	1	1	1
Electrical												
Input Voltage, VDC:			±12 to ±18			±12 to ±18			±12 to ±18			
Input Current, mA, nominal:			15			25			15			
Output Impedance, ohms, nominal:			100			100			100			
Output Impedance, LSR:	15k	5k	16k	8k	4k							
Noise, mV rms, maximum:			0.002			0.0005			0.002			
Environmental												
Operating Temp Range:			-20° C to +71° C			-55° C to +85° C			-40° C to +85° C			
Survival Temp Range:			-40° C to +71° C			-60° C to +90° C			-60° C to +90° C			
Shock:			1500g, 0.5msec, 1/2 sine			100g, 11msec, 1/2 sine			1000g, 1msec, 1/2 sine			
Vibration:			20 grms			1 grms			20 grms			
Weight:			13.0 oz.			3.0 oz.			5.0 oz.			

¹ Full Range is defined "from negative full input angle to positive full input angle."

² Nonlinearity is specified as deviation of output referenced to theoretical sine function value, independent of misalignment.

³ Output Phase angle = -90°.

Inclinometers



LCF-196 Biaxial

The LCF-196 inclinometer provides a biaxial output in a 23mm diameter package. It is a high accuracy sensor designed for applications where high levels of shock and vibration are present. The signal is typically input to analog or digital data recording systems.



4 to 20 milliamp output LSO

This LSO inclinometer is designed for applications where high levels of ambient electrical noise are present and/or long cable runs are required.



LCF-2000 Biaxial

The two axis version of the rugged, high accuracy LCF-100 is available with a wide range of options including single ended input power, an internal temperature sensor, and 4 to 20 milliamp output.



Digital Display

AIR-1000 Inclinometer Angle Readout

The AIR-1000 is a microprocessor-based panel meter that displays the trigonometric output of a Jewell gravity referenced inclinometer as an angle equivalent with 0.001° resolution. The 120VAC input AIR-1000 provides ±15 volt sensor power and an RS-232 digital output.

LCA-100, LCF-100, LCF-200, and LCM Series

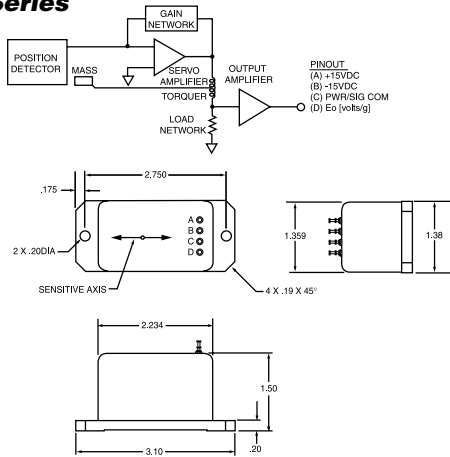

LCI

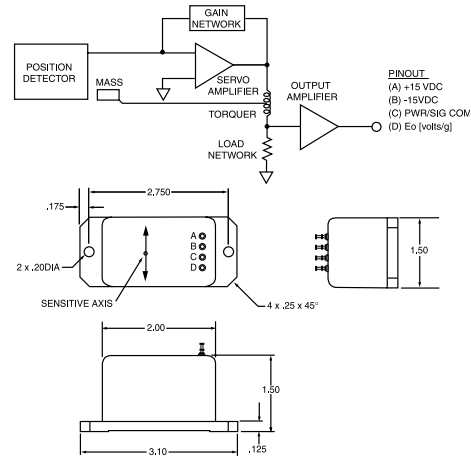

LSR

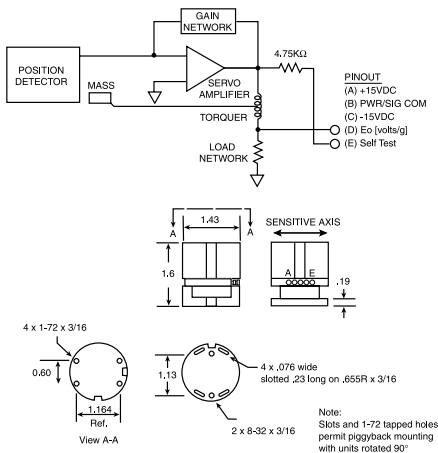

LSOC/P

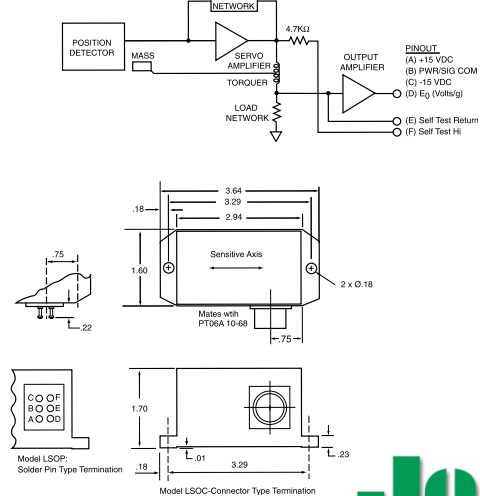

Digital Inertial Sensor

The LDF series digital inclinometer takes Jewell Instruments' highly accurate and robust force balanced technology to the next level. Jewell's LDF series digital inclinometer is available with an RS-422 serial interface. Its onboard processor allows

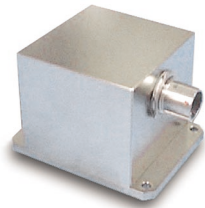

LDF-1600

the LDF series inclinometer to compensate for errors, including temperature, ensuring the highest level of accuracy over the entire operational temperature range of the sensor. The LDF series features a wide input power supply range of 6 to 50VDC and customizable bandwidth from DC to over 100Hz making it extremely versatile. This advanced sensor comes standard with a -5 to +5VDC analog output for operation with systems requiring analog input. Jewell provides this advanced sensor in a rugged, sealed package. Jewell does it once again, providing this advanced, high accuracy and robust solution for your tilt sensing problems. There is nothing else in its class.

Features:

- $\pm 90^\circ$ ($\pm 1g$) Full Range
- RS-422 serial interface
- Wide input power supply range from 6 to 50VDC
- Outstanding resolution
- Customizable bandwidths from DC to 100Hz
- Includes standard -5 to +5VDC analog output
- Advanced temperature compensation ensures high accuracy over a -40°C to $+80^\circ\text{C}$ temperature range
- Proprietary protocol contains advanced forward error correction and error detection
- Rugged, sealed package with a military subminiature cylindrical connector that is scoop-proof and has a bayonet lock coupling

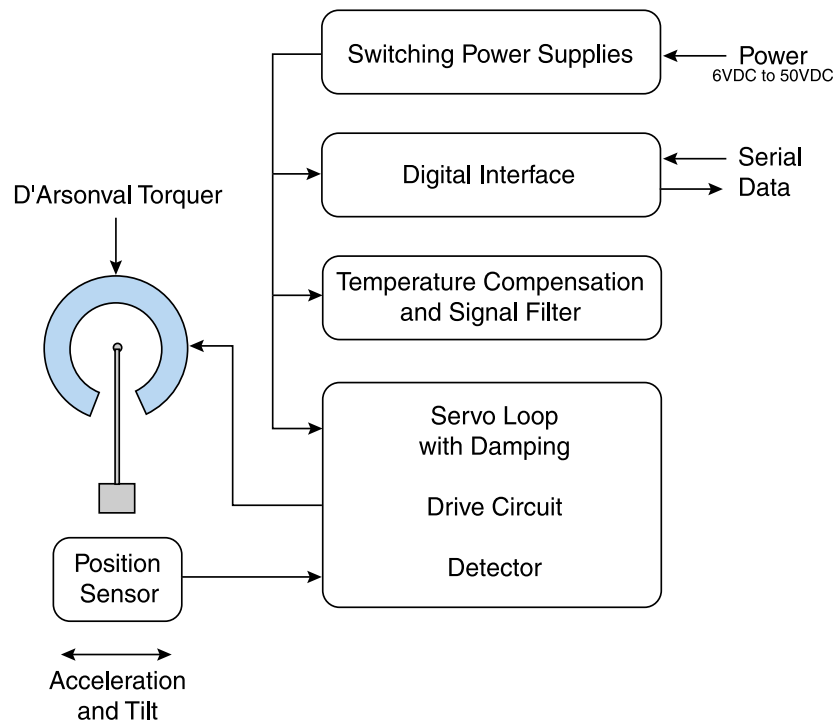

Custom-Engineered Solutions

Jewell specializes in custom-designed, high-accuracy, inertial sensing solutions. Our sensors solve unique application problems where standard, off-the-shelf sensors simply won't do. More companies choose custom-engineered Jewell tilt sensors because of:

- Our high-value, high-accuracy, rugged designs
- Our willingness and capability to design and engineer custom solutions based on our proven methodologies
- Our applications expertise enabling us to understand what will work, what won't work, and what the trade-offs will be in virtually any design

For many aerospace and industrial applications, our sensors are the perfect custom solution. Here are several inertial sensor application challenges and our custom-engineered solutions to them:

Railcar Control

Acceleration and deceleration control is critical in railcars and people movers. The input dynamics of these systems are constantly changing as people board and disembark. Accelerometers measure the inputs for speed-control systems that adjust vehicle acceleration resulting in a safe and comfortable ride.

Our LCF-200-2g has been custom-engineered to meet the special demands of railcar control. A customized frequency response system meets the demands of the unique dynamics encountered in railcar applications. This sensor includes ruggedized electrical components to ensure durability for this demanding application.

Flight Control

Flight control systems make many routine adjustments to attitude and direction in the course of a flight using accelerometers. Flight control accelerometers require high accuracy, high reliability and must conform to aircraft standards such as 28V unipolar inputs.

The g-limiter is a complete system operating from 28VDC input, including a DC/DC converter, a high-accuracy servo accelerometer, and a comparator. The system output is a measured change in output-state. It is derived from the relationship between the input acceleration and internal reference acceleration. Application specific signal conditioning and redundant systems are built into each unit.

The LCA-165/167 are high performance pivot and jewel 5g and 10g accelerometers used in autopilot applications. The output of the LCA-165/167 is electrically isolated from the input power.



The LSXF is the custom solution of choice for aircraft stability and control applications. The LSXF is a low-range accelerometer with milli-g accuracy in the presence of 20grms vibration. Its mechanical input-energy attenuation and unique servo characteristics yield a high accuracy. Rugged features include a solid aluminum machined housing and specially encapsulated electronics ensuring components remain intact regardless of external forces. EMI/RFI filtering is included.

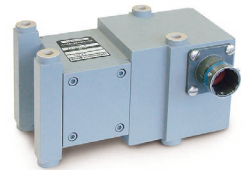

Missile

Today's smart weapons rely on integrated missile guidance systems to deliver strikes accurately and in some cases evade enemy early detection systems. Accelerometers are an essential component of these systems – collecting input data to determine if the missile is on course and delivering that data to a guidance control system so that the missile can reach its intended target.

The rugged LCA-215 unit delivers accurate information in a high-vibration environment. A specially engineered servo loop includes frequency rejection, enabling accurate output of 0 to 10g acceleration in the midst of high vibration and acoustic noise.



Custom-Engineered Solutions



Antenna Orientation

Custom force balance inclinometers are employed in many fire control systems and mobile antenna leveling applications. They accurately measure slope and tilt of the installation enabling automated leveling of a weapon's platform or target acquisition radar.

The LCF-2310 is a biaxial accelerometer used in a variety of fire control applications. This ruggedized unit produces a highly accurate, low noise output with a low pass filtered bandwidth. EMI/RFI filtering is also included.

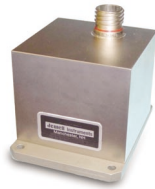

Ship and Barge Leveling

Signals from an inclinometer installed on a ship or barge are sent to a ballast transfer hydraulic system. The inclinometer is also employed for closed-loop leveling of equipment in underwater drilling and mining operations.

The LCF-2450 has infinite resolution and high sensitivity for very high accuracy and level control. Its rugged design features a machined aluminum, all-weather housing.

Deviation Surveys

Used for borehole mapping and deviation surveys, our inclinometers respond to borehole deviations as small as 0.1 second of arc.

Angular Acceleration

Accelerometers contribute in a variety of angular acceleration functions. Jewell application engineers excel at providing custom solutions for flight control systems such as autopilot or aircraft stability and control systems or satellite stability.

Our ASXC-100 is a rugged, fluid-rotor angular accelerometer, sensitive to very small angular acceleration. A fluid rotor enables high sensitivity without relying on a large mass supported by a fragile bearing system. This rugged design enables the ASXC-100 to respond to tiny angular inputs. Available in ranges from 1 radian/second² to 100 radians/second² full scale.



**Full scale ranges of
1 radian/sec² to
±100 radians/sec²**

The ASBC angular accelerometer is a general purpose device made for industrial, commercial and aerospace sensing requirements. Its many applications include antenna stabilization, torque measurement, flight control systems, automotive testing, and optical system stabilization.



**Full scale ranges of
200 radians/sec² to
±1000 radians/sec²**

Analog Principles of Operation

Jewell accelerometers and inclinometers are precision inertial instruments. They utilize closed loop sensor technology to produce a highly accurate output at a relatively low price for the specified performance. The inertial sensor output is an analog voltage proportional to applied acceleration and tilt from DC through a specified frequency.

Note that an accelerometer and an inclinometer are the same device. The distinction is one of application, not operation. Accelerometer users typically sense changes in velocity and characterize outputs and errors in g. Inclinometer users sense changes in angular position and think of outputs and errors in units of angular measurement. Jewell inertial instruments respond to both earth's gravity and acceleration.

The sensing element in a Jewell inertial instrument is the torquer, a D'Arsonval mechanism designed specifically for sensor use. Jewell has produced inertial instrument torquers and complete acceleration sensing assemblies for many years. Hundreds of thousands of acceleration sensors have been manufactured. Jewell sensors are used throughout the world for detecting acceleration and tilt from less than one μg (one μRadian) to more than 50g.

The torquer mechanism is typically the most expensive subassembly in a servo sensor. Torquers are sophisticated meter movements, and Jewell, as a meter manufacturer, can produce torquers very efficiently. We, therefore, often have a cost advantage when compared to other conventional technology inertial instrument producers.

A torquer used to sense acceleration or tilt is intentionally unbalanced in its plane of allowable angular motion. When acceleration or tilt is present, a torque proportional to the mechanism unbalance and the physical input is developed. The torque results in an angular motion sensed by a position detector. The position detector output is compared to a reference voltage, and the difference is an error signal that is the input to a servo amplifier. The servo amplifier output current is applied to the torquer in opposition to the acceleration or tilt torque. At a constant inertial input, the torquer mechanism angular position is minutely different from the zero g position. The servo amplifier output current is directly proportional to the applied acceleration or sine of the input tilt angle. An analog voltage is produced by measuring the servo current with a sense resistor.

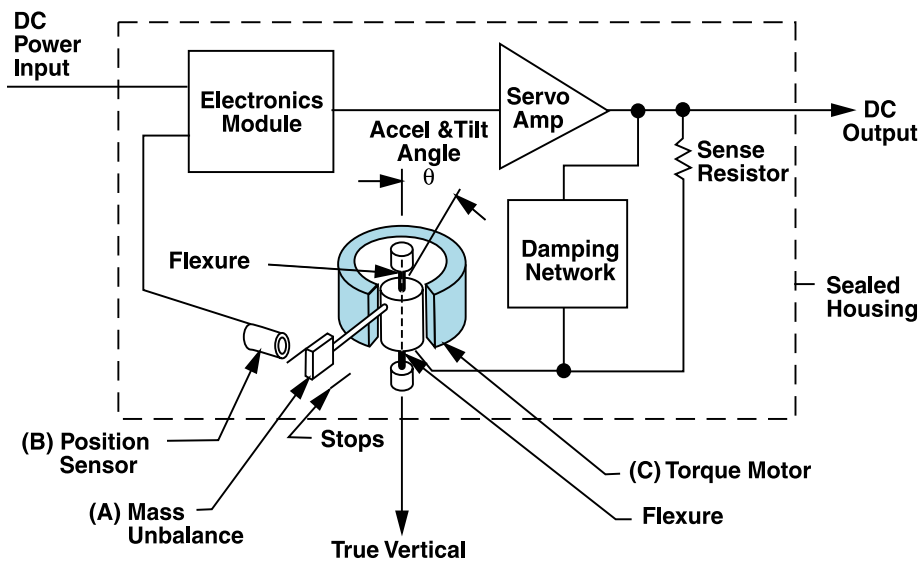

Understanding the Specifications

The following information describes how Jewell Instruments interprets performance characteristics and error sources often listed in inertial instrument specifications. The Jewell interpretation is generally consistent with IEEE accelerometer test conventions.

Range and Scale Factor

The range of an accelerometer or inclinometer is the input from + to - over which the transducer is expected to yield the specified output. A $\pm 2g$ accelerometer has an input range of $4g$. The scale is one half the range, $2g$ in the example given.

Jewell inertial sensors operating at ± 15 volt bipolar input voltage have an operating overrange capability of 50% to 100%. A 30° inclinometer, for example, will operate without meaningful performance degradation to 90° . The sine of 90° (1.00) being twice the sine of 30° (0.50). Beyond 100% overrange, the output voltage will begin to clip. The overrange capability for unipolar input power units is typically limited to less than 25% by the available input or output voltage. Units with 4-20mA output are limited by the voltage to current converter at less than 5% overrange.

Natural Frequency and Damping

The accelerometer or inclinometer dynamics can be treated as second order for most Jewell designs.

The natural frequency is the frequency at which the phase of the accelerometer or inclinometer output lags the input by 90° .

The bandwidth of an accelerometer or inclinometer is defined as the frequency range below the frequency at which the amplitude of the output is 3dB down relative to the input.

Bias

The bias is the accelerometer output when no acceleration is applied. Bias results primarily from residual suspension torque. The output from a stationary accelerometer or inclinometer on a flat surface is a combination of bias, misalignment and noise. Some data sheets specify unit output on a horizontal surface as Output at Zero Tilt. Output at Zero Tilt is the combined output axis misalignment and bias.

Input Axis Misalignment

The input axis misalignment is the geometric sum of the pivot (output) axis and pendulous axis misalignments relative to the base and a reference side of the accelerometer. The standard alignment is a function of sensing range. The alignment specification in the data sheets is the maximum misalignment of either (or both) transverse axes.

Cross axis acceleration or tilt is sensed by an inertial instrument as a function of the sine of the misalignment angle.

Nonlinearity

Nonlinearity is the largest deviation in the accelerometer output curve over its specified input range when the output is compared to a least squares best fit straight line.

Resolution and Threshold

Threshold is the smallest input change that will result in a meaningful (50% of expected) output change at zero. Resolution is the smallest input change anywhere in the operating range that will result in a meaningful output change. Resolution and threshold errors are not always the same for accelerometers and inclinometers. The resolution of many standard units is, in fact, infinitely small.

Repeatability

Repeatability defines an area of output uncertainty within which the sensor may yield different outputs for identical inputs. The uncertainty is usually a function of moving system suspension friction and position errors. Flexure suspension units have relatively small repeatability errors. Pivot and jewel units can have 0.001g to 0.005g of uncertainty. Observed repeatability is application dependent. Pivot and jewel units have better than expected "real life" repeatability when some vibration is present. The vibration energy helps reduce the effect of bearing friction.

Noise

Noise is the dynamic output from the accelerometer when no acceleration input is present.

Understanding the Specifications

Input Voltage

The input voltage specified is the range of voltages over which the unit is expected to operate within specification. If the input voltage is increased beyond the specified range, an accelerometer or inclinometer will continue to operate. At higher input voltages, additional current is required. The internal heat dissipation increases, and component life begins to decrease. Most units will also continue to operate at input voltages below the specified range. The output voltage clipping level and overrange capability are decreased at lower input voltages.

Alternate input power choices including 5 volts, 12 volts and 28 volts single ended as well as ± 5 volts bipolar are available.

Input Current

The input current is the current the accelerometer or inclinometer will draw from a power supply at the specified nominal operating voltage. For bipolar input units, the positive and negative currents are not necessarily balanced.

It is possible to reduce the current requirement, but applications must be evaluated on an individual basis.

Output Impedance

The standard output configuration is an operational amplifier with 100 ohms in series with the output. Other configurations including direct output across the load resistor, or use of an external load resistor, are possible.

Operating Temperature Range

The operating temperature range defines the temperature extremes over which the accelerometer or inclinometer will work without temperature induced failure or a permanent change in some output characteristic. A unit will continue to operate at temperatures somewhat higher or lower than stated in the standard specifications, but damage is likely.

Survival Temperature Range

The survival temperature range defines the temperature extremes a unit can be exposed to without damage when it is not powered.

Shock and Vibration

Shock indicates the highest shock level that the accelerometer or inclinometer can be exposed to without damaging the unit. The specified shock cannot be applied an infinite number of times.

Random vibration limits are specified for 3-hour exposure to white noise in the bandwidth 20Hz to 2000Hz.

The highest continuous acceleration level that can be applied without damage is typically 30g, but must be evaluated on an individual application basis if constant acceleration greater than 10g is present.

Seal

Sealing specifies the design technique selected to prevent moisture, dust, or other external contaminant from entering the sensor housing.



Facilities

We offer two, fully modernized manufacturing facilities in Manchester, New Hampshire and Barbados, West Indies. Both are fully capable of handling the most stringent manufacturing requirements while our Barbados facility also provides the extremely cost-competitive advantage of an offshore manufacturer.

Manchester, New Hampshire

- 60,000 square foot headquarters facility features R&D, engineering, and manufacturing personnel dedicated to Jewell's products and Partnership Manufacturing
- Located at Manchester Airport, one hour north of Boston



Barbados, West Indies

- 30,000 square foot offshore manufacturing facility features a dedicated Jewell team experienced at providing low-cost, high-quality manufacturing



Products



Meters

A complete selection of panel meters for virtually every use, from simple analog power meters to complex selectable-function digital meters



Solenoids

High performance, cost-effective frame and tubular solenoids



Avionics

Indicators and instrumentation for aviation, including complete instrument clusters



Partnership Manufacturing

Precision sub-assemblies and complete products manufactured to order for a wide range of industrial, commercial, avionic, and military applications



Jewell Instruments, LLC

850 Perimeter Road, Manchester, NH 03103 USA

Tel. 603-669-6400 • Fax 603-669-5962

Toll Free 800-METERS-1 • 800-638-3771

sales@jewellinstruments.com • www.jewellinstruments.com