

Dimensions

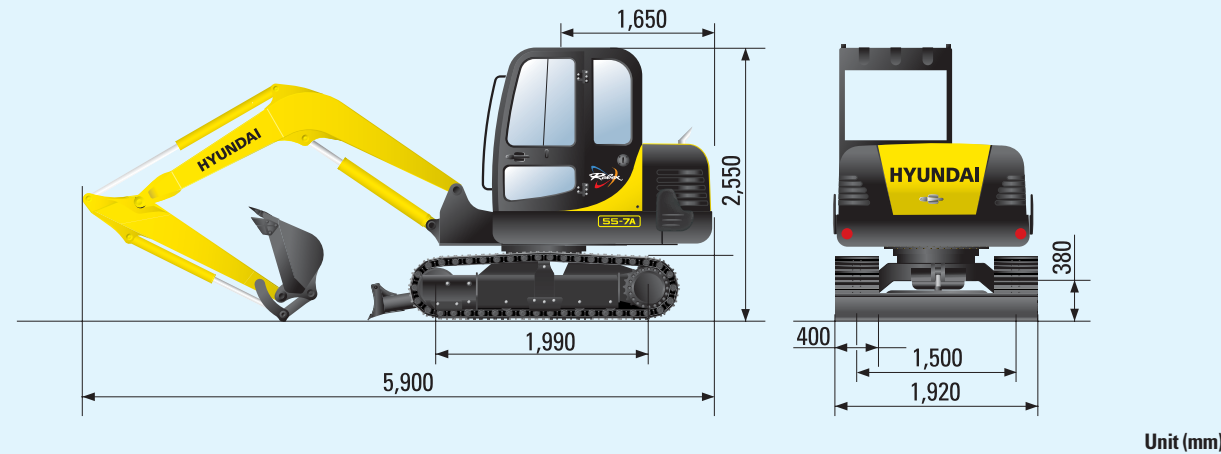

Unit (mm)

Working Ranges

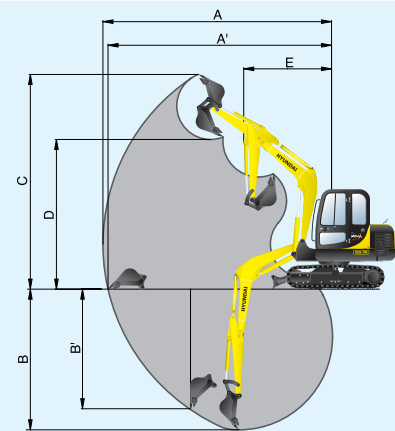

Boom length	3,000 mm(9' 10")	
Arm length	※ 1,600 mm(5' 3")	1,900 mm(6' 3")
A Max. digging reach	6,150 mm(20' 2")	6,400 mm(21' 0")
A' Max. digging reach at ground	6,010 mm(19' 9")	6,270 mm(20' 7")
B Max. digging depth	3,820 mm(12' 6")	4,060 mm(13' 4")
B' Max. digging depth (8ft level)	3,420 mm(11' 3")	3,700 mm(12' 2")
C Max. vertical wall digging depth	3,200 mm(10' 6")	3,460 mm(11' 4")
D Max. digging height	5,780 mm(18' 12")	5,920 mm(19' 5")
E Max. dumping height	4,050 mm(13' 3")	4,180 mm(13' 9")
F Min. front radius	2,350 mm(7' 9")	2,360 mm(7' 9")

Standard Equipment

ISO standard cabin

- Cabin ROPS(ISO 3471)
- FOPS(ISO 3449)
- TOPS(ISO 12117)
- All-weather steel cab with all-around visibility
- Safety glass windows
- Sliding fold-in front window
- Sliding side window
- Lockable door
- Accessory box & Ash-tray

Heater & Defroster

Centralized monitoring

- Engine speed
- Gauges
- Fuel level gauge
- Engine coolant temperature gauge
- Warning
- Fuel level
- Engine oil pressure
- Engine coolant temperature
- Hyd. oil temperature
- Low battery
- Air cleaner closing
- Fuel prefilter

Door and cab locks, one key

- AM/FM radio and cassette
- Two outside rear view mirrors
- Fully adjustable suspension seat with seat belt
- Console box tilting system(LH.)
- Four front working lights
- Electric horn
- Battery (1 x 12 V x 100 AH)
- Battery master switch
- 12 volt power supply(DC-DC converter)
- Removable clean out screen for radiator
- Automatic swing brake
- Removable reservoir tank
- Water separator, fuel line
- Counterweight (210 kg, 460 lb)
- Mono boom (3.0 m, 9'10")
- Arm (1.6 m, 5' 3")
- Track shoes (400 mm, 15.7")
- Track rail guard

Optional Equipment

- Air-conditioner(4000 kcal/hr, 16000BTU/hr)
- Fuel filler pump(35 ℓ /min, 9.2 US gpm)
- Beacon lamp
- Piping kit (breaker, etc)
- Double acting piping kit(clamshell, etc)
- Accumulator, work equipment lowering
- Electric transducer
- Travel alarm
- Quick coupler
- Rubber crawler (400mm, 16")
- Narrow bucket(0.07m³, 0.09yd³)
- Arm (1.9m)
- Tool kit
- Operator suit
- Mechanical suspension seat with heater

Standard and optional equipment may vary. Contact your Hyundai dealer for more information. The machine shown may vary according to International standards. All US measurement are rounded off to nearest pound or inch.

HYUNDAI
HEAVY INDUSTRIES CO., LTD.
CONSTRUCTION EQUIPMENT

Head Office
(Sales Office) 1 JEONHA-DONG, DONG-GU, ULSAN, KOREA
Tel (82) (52) 202-7970, 7729 Fax (82) (52) 202-7979, 7720

U.S. Operation
Hyundai Construction Equipment U.S.A., Inc.
955 ESTES AVENUE, ELK GROVE VILLAGE IL, 60007
Tel (1) 847-437-3333 Fax (1) 847-437-3574

European Operation
Hyundai Heavy Industries Europe N.V.
VOSSENDAAL 11, 2440 GEEL, BELGIUM
Tel (32) 14-562200 Fax (32) 14-593405-06

PLEASE CONTACT

www.hyundai-ce.com

2008. 03 Rev.0.



Some of the Photo may include optional equipment.

55-7A MINI CRAWLER EXCAVATOR Applied Tier 3 Engine

55-7A

HYUNDAI
HEAVY INDUSTRIES CO., LTD.

We build a better future

Hyundai Robex 55-7A

- Maximized Workability
- Comfortable Operating Environment
- Advanced Hydraulic System
- Enhanced Durability & Reliability
- Improved Fuel Efficiency

The Highest Engine Power in its Class **YANMAR 4TNV98-EPHYB**

57 HP / 2,400 rpm

Yanmar 4TNV98-EPHYB engine provides 20.5 kgf-m (148 lbf-ft) of maximum torque with 57 HP at 2,400rpm of rated power. This means the R55-7A runs with the most power in its class, giving you more power to get the job done.

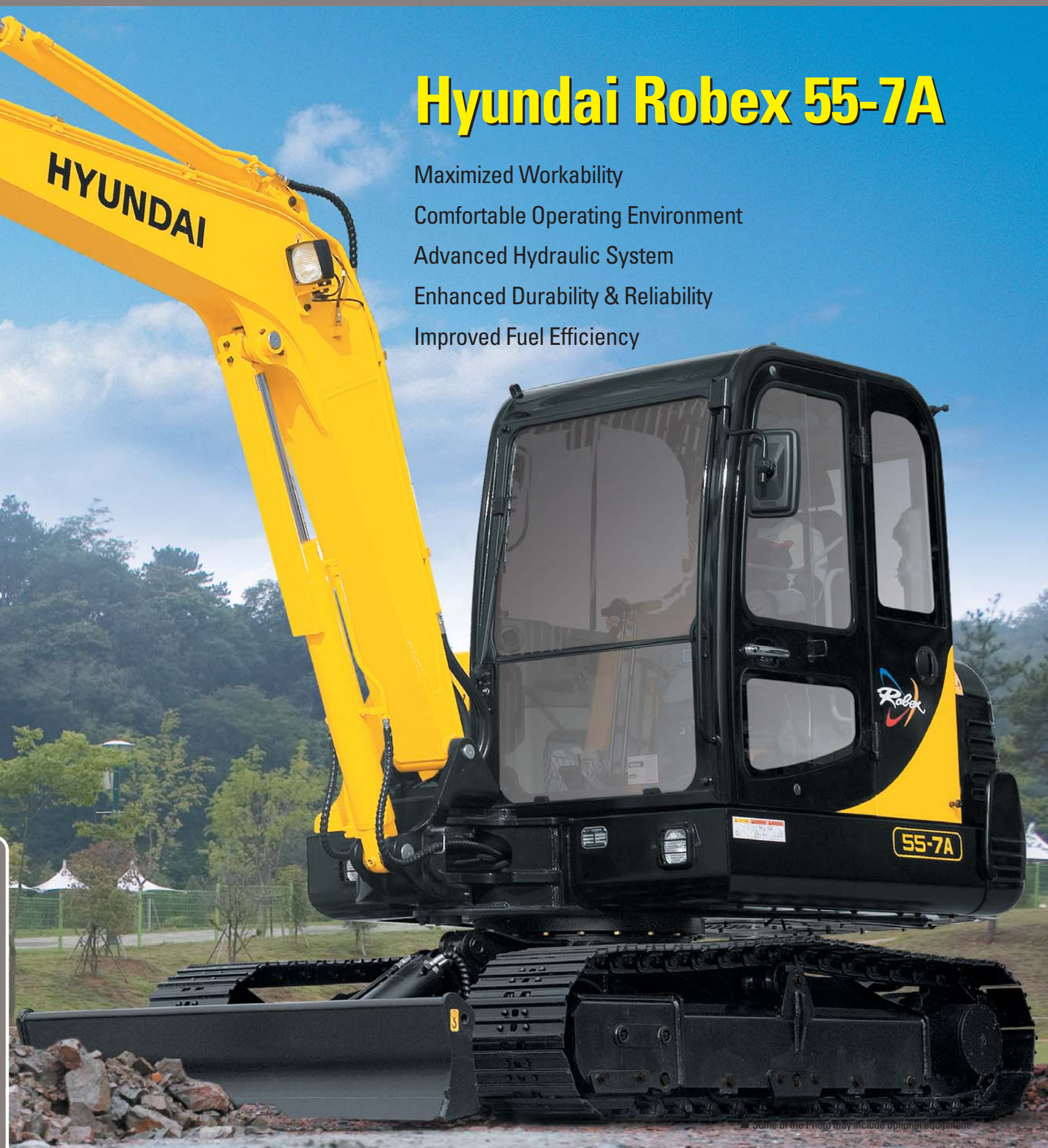

Technology in Cab Design

Wide Comfortable Operating Space

All the controls are designed and positioned according to the latest ergonomic research. Reinforced pillars have also been added for greater cab rigidity.



Some of the Photo may include optional equipment.



Reliable Instrument Panel

All information from the devices such as engine RPM, engine water temp., fuel status and the state of all types of electric switches provide the operator with an exact condition of machine. These features make troubleshooting much easier.

M M MODE : High power

Reliable Instrument Panel



Radio & Cassette Player

Deluxe radio & cassette player are located at convenient position.



Dial Type Engine Speed Switch and Key Switch



Wide Cab with Excellent Visibility

The cab is roomy and ergonomically designed with low noise level and good visibility. A full view front window and large rear and side windows provide excellent visibility in all directions.



High-output Air Conditioner & Heater

Large capacity air conditioning system is installed for operator's comfort in all climate. For more convenience, the cab is equipped with defroster for the cold seasons.



Sensitive Joystick and Easy Entrance

New joystick grips for precise control have been equipped with 4 switches. Tilting tower combined with large door provides more space for gateway.

Left	Horn/Dummy
Right	Breaker/Dummy



Smooth Travel Pedals and Foot Rests

Travel pedals and levers are equipped with ergonomically designed foot rests. It enables the operator to work easily and quickly.

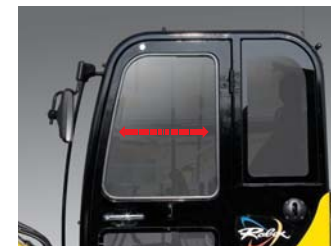

Sliding Side Window

The sliding side window provides more convenience for the operator without having to opening the door.



Big Sized Sun Visor & Top Glass

The big sun visor and top glass are installed on the top of the front window to block direct sunlight and increase operator's visibility.

Top Glass : Bronze color and laminated glass



Rise-up Wiper

Rise-up wiper gives better front view to operator.



Easy to Open Front Window

Sliding fold-in front window is easily opened and safely maintained in open position to improve the working condition.

**Unparalleled Technology of R55-7A.
It will fulfill your dreams**



Strong and Stable Lower Frame

Reinforced box-section frame is all welded with low-stress and high-strength steel.



Some of the Photo may include optional equipment

Powerful and Dynamic Work



■ Some of the Photo may include optional equipment.



Exceptional Traction & Lifting Capacity
The considerable traction and lifting capacity enable all work to be done quickly.



Reinforced Bucket
The design includes bucket link durability and anti-wear characteristics with additional reinforcement plates on cutting edge section. Reinforced bucket is made with thicker steel and additional lateral plate.

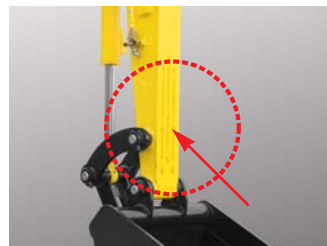

Reinforced Arm
Reinforcements are welded to protect the arm from impacts and wear.



Gradeability
35 degree(70%) of high gradeability and long tumbler distance may be easier to work at slope area.



Anti Restart System
The new system protects the starter from re-starting during engine operation, even if the operator accidentally turns the start key again.



Easy-to-Reach Control Panels
Switches and other essential controls are located near the operator. This helps keep operator movement to a minimum, enhancing control with less operator fatigue.



Installation for Breaker Operation
Overload relief valve and pipes are installed as standard for customer's convenience.



Offset Boom Swing
The R55-7A is designed for efficient work in congested residential and urban areas. The boom can be offset within a range of 130 degrees.

Performance and Durability



Some of the photo may include optional equipment.



Arrangement Between Bucket and Blade

Attachment is designed to minimize dead space between bucket and blade for efficient grading work.



Powerful Dozer Blade

Large size blade improves work efficiency and equipment durability.

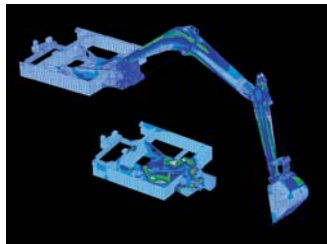

FEM(Finite Element Method)

Durability of structure is proven through FEM(Finite Element Method) analysis and long term durability test.

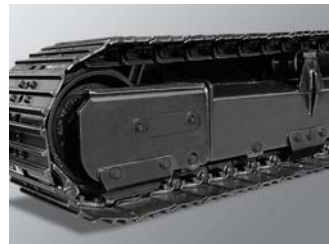

Tough, Durable Undercarriage

The R55-7A has an undercarriage constructed with tough, durable, robotically-welded steel. Tapered, upper roller side supports were installed to keep tracks properly aligned at all times.



Steel Tube Frame Cabin

Strong cabin structure protects the operator against falling objects, improves operator's safety with seat-belt in the event of roll-over. (ROPS, FOPS, TOPS STD.)



Boom Cylinder Cover

Boom cylinder cover is installed as standard to prevent cylinder damage.



Applied Side Protector

When the machine turns, the side protector prevents any damage to engine hood.



Large Capacity Radiator

To improve the performance in overload or continual work, large capacity radiator was installed.

Reliability and Serviceability

Full open doors and master key system provide easy access for servicing.



Easy to Maintain Engine Components

The R55-7A is designed with accessibility in mind. All doors, covers and hoods are built for complete open access. You'll find that the R55-7A offers plenty of space to complete your regular maintenance and service hassle-free.



Long Life Hydraulic Filter

Uses high-performance filtering materials are applied for extending the filter replacement interval.

■ Some of the Photo may include optional equipment.



Easy Change of Air Cleaner

The R55-7A is fitted with durable plastic air cleaner for easy maintenance and quick service.

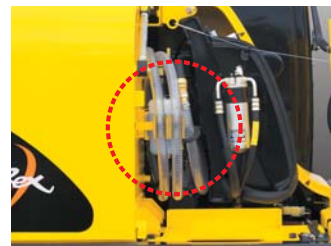

Easy to Fill up with Fuel (Option)

The Fuel filler pump provide easy filling of fuel tank from other tanks by electric device.

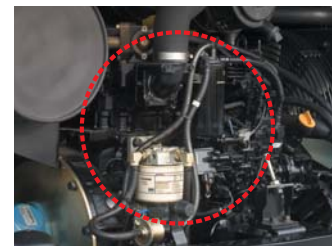

High Capacity Prefilter & Fuel Filter

To protect the injection system and minimize the risk of fuel breakdown, high capacity fuel filter and prefilter are applied for durability.



Centralized Grease Fittings

Grease fittings are highlighted and centralized for fast access when doing your service checks. Save time and money during routine maintenance.



Centralized Fuse Box

Fuse box is arranged on the rear of seat for easy service.



Large Capacity Fuel Tank

The large capacity of fuel tank provides longer working time.



Battery Master Switch

The battery master switch enables checking and maintaining the battery while minimizing the discharge of battery.



Smooth and precise swing control

Shock absorbing design is more improved to stop and start swing precisely and smoothly.

Engine

Model	YANMAR 4TNV98-EPHYB	
Type	Water cooled, 4 cycle diesel 4 cylinders in line, direct injection, low emission	
Rated flywheel horse power		
SAE	J1995 (gross)	57 HP (42.5 kW) at 2,400 rpm
	J1349 (net)	55.2 HP (41.2 kW) at 2,400 rpm
DIN	6271/1 (gross)	57.8 PS (42.5 kW) at 2,400 rpm
	6271/1 (net)	56 PS (41.2 kW) at 2,400 rpm
Max. torque	20.5 kgf-m (148 lbf-ft) at 1,550 rpm	
Bore x stroke	98 mm (38.6") x 110 mm (4.33")	
Displacement	3,319 cc (203 cu in)	
Battery	1 x 12 V x 100 AH	
Starter motor	12V-3.0 kW	
Alternator	12V-80 A	

Hydraulic System

Main pump	
Type	Two variable displacement piston pumps
Rated flow	2 x 55.2 l /min(14.5 US gpm/12 UK gpm)pumps
Sub-pump for pilot circuit	Gear pump
Hydraulic motors	
Travel	Two speed axial piston motor with counter balance valve and parking brake
Swing	Axial piston motor with automatic brake
Relief valve setting	
Implement circuits	220 kgf/cm ² (3,130 psi)
Travel circuit	220 kgf/cm ² (3,130 psi)
Swing circuit	220 kgf/cm ² (3,060 psi)
Pilot circuit	30 kgf/cm ² (430 psi)
Service valve	Installed
Hydraulic cylinders	
No. of cylinder-bore x rod x stroke	Boom : 1 - 110 x 65 x 715 mm (4.3" x 2.6" x 28.1") Arm : 1 - 90 x 55 x 850 mm (3.5" x 2.2" x 33.5") Bucket : 1 - 80 x 50 x 660 mm (3.1" x 2.0" x 26.0") Boom swing : 1 - 95 x 50 x 527 mm (3.7" x 2.0" x 20.7") Dozer blade : 1 - 110 x 60 x 214 mm (4.3" x 2.4" x 8.4")

Drives & Brakes

Drive method	Full hydrostatic type
Drive motor	Axial piston motor, in-shoe design
Reduction system	Planetary reduction gear
Max. drawbar pull	5,300 kgf (11,700 lbf)
Max. travel speed(high) / (low)	4.1 km/hr (2.5 mph) / 2.2 km/hr (1.4 mph)
Gradeability	35° (70%)
Parking brake	Multi-wet disc

Swing System

Swing motor	Axial piston motor
Swing reduction	Planetary gear reduction
Swing brake	Multi wet disc
Swing speed	9.3 rpm

Controls

Pilot pressure-operated joysticks and pedals provide almost effortless and fatigueless operation.

Pilot control	Two joysticks with one safety lever (LH): Boom Swing and arm, (RH): Boom and bucket(ISO)
Traveling and steering	Two levers with pedals
External Lights	Two lights mounted on the boom one below the cab

Coolant & Lubricant Capacity

(Refilling)	liter	US gal	UK gal
Fuel tank	120.0	31.7	26.4
Engine coolant	10.0	2.6	2.2
Engine oil	11.6	3.1	2.6
Swing device-gear oil	1.5	0.4	0.3
Final drive(each)	1.2	0.3	0.2
Hydraulic tank	70.0	18.5	15.4
Hydraulic system	120.0	31.7	26.4

Undercarriage

X-leg type center frame is integrally welded with reinforced box-section track frames. The undercarriage includes lubricate rollers, track adjusters with shock absorbing springs and sprockets, and track chain with triple grouser shoes.

Center frame	X - leg type
Track frame	Pentagonal box type
No. of shoes on each side	40
No. of carrier roller on each side	1
No. of track roller on each side	5

Operating Weight (approximate)

Operating weight, including 3,000 mm (9' 10") boom, 1,600 mm (5' 3") arm, SAE heaped 0.18 m³ (0.24 yd³) digging bucket, lubricant, coolant, full fuel tank, hydraulic tank and the standard equipment.

Major component weight	
Upper structure	2,650 kg (5,840 lb)
Counterweight	200 kg (440 lb)
Mono boom(with arm cylinder)	310 kg (680 lb)
Operating Weight	
Operating weight kg(lb)	5,700 (12,570)

· Mono boom with blade

Buckets

Capacity		Width		Weight	3.0m (9' 10") Boom	
SAE heaped	CECE heaped	Without side cutters	With side cutters		1.6m (5' 3") arm	
0.07 m ³ (0.09 yd ³)	0.06 m ³ (0.08 yd ³)	315 mm(12.4")	360 mm(14.2")	84 kg(185 lb)	■	
* 0.18 m ³ (0.24 yd ³)	0.15 m ³ (0.20 yd ³)	670 mm(26.3")	735 mm(29.0")	137 kg(300 lb)	■	

* : Standard digging bucket ■ : Applicable for materials with density 1,600 kg/m³(2,700 lb/yd³) or less ▲ : Applicable for materials with density 1,100 kg/m³(1,850 lb/yd³) or less

Arm	Length	* 1,600 mm (5' 3")		1,900 mm (6' 3")	
		Weight	210 kg (460 lb)	230 kg (510 lb)	37.7 kN
Bucket digging force	SAE	37.7 kN	37.7 kN	3,850 kgf	3,850 kgf
		8,490 lbf	8,490 lbf	42.4 kN	42.4 kN
	ISO	4,330 kgf	4,330 kgf	9,550 lbf	9,550 lbf
		28.4 kN	25.5 kN	2,900 kgf	2,600 kgf
Arm crowd force	SAE	6,390 lbf	5,730 lbf	31.9 kN	28.7 kN
		3,260 kgf	2,930 kgf	7,190 lbf	6,460 lbf
	ISO	31.9 kN	28.7 kN	3,260 kgf	2,930 kgf
		7,190 lbf	6,460 lbf		

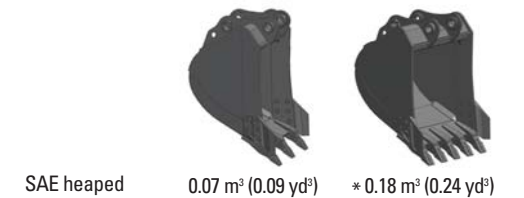

Lifting Capacities R55-7A

· Boom : 3.0m (9' 10") · Arm : 1.9 m (6' 3") · Bucket : 0.18m³ (0.24yd³) SAE heaped · Dozer blade down with 200kg (440 lb) counterweight.

Load point height m(ft)		Load radius								At max. reach		
		2.0m(5ft)		3.0m(10ft)		4.0m(13.12ft)		5.0m(16.40ft)		Capacity		Reach m (ft)
		SAE	ISO	SAE	ISO	SAE	ISO	SAE	ISO	Capacity	Reach	
5.0m (16.40ft)	kg									*950	*950	4.12 (13.5)
4.0m (13.12ft)	kg					*1020	*1020			*2090	*2090	5.07 (16.6)
3.0m (10ft)	kg					*1090	1070			880	600	5.59 (18.3)
2.0m (5ft)	kg	*3060	*3060	*1690	1610	*2930	2250	1030	710	1790	1210	5.83 (19.1)
1.0m (5ft)	kg	*6750	*6750	*3730	3550	2230	1490	1420	970	2200	1500	5.84 (19.2)
Ground Line	kg	*2340	*2340	2160	1430	1380	930	990	670	1850	1230	5.62 (18.4)
-1.0m (-5ft)	kg	*3600	2760	2140	1410	1360	920	2120	1430	960	650	5.13 (16.8)
-2.0m (-5ft)	kg	*3780	2800	2160	1430	1360	910	*2540	1980	*1150	900	4.22 (13.8)
-3.0m (-10ft)	kg	*2060	*2060									
	lb	*4540	*4540									

· Boom : 3.0m (9' 10") · Arm : 1.9 m (6' 3") · Bucket : 0.18m³ (0.24yd³) SAE heaped · Dozer blade down with 200kg (440 lb) counterweight.

Load point height m(ft)		Load radius								At max. reach		
		2.0m(5ft)		3.0m(10ft)		4.0m(13.12ft)		5.0m(16.40ft)		Capacity		Reach m (ft)
		SAE	ISO	SAE	ISO	SAE	ISO	SAE	ISO	Capacity	Reach	
5.0m (16.40ft)	kg									*870	*870	4.56 (15.0)
4.0m (13.12ft)	kg									*1920	*1920	5.89 (19.3)
3.0m (10ft)	kg					*950	*950	*1000	730	*1980	1430	6.12 (20.1)
2.0m (5ft)	kg					*2090	*2090	*2200	1610	1790	1210	6.13 (20.1)
1.0m (5ft)	kg	*2090	*2090	*1450	1510	*1200	1030	1030	710	2270	1570	6.13 (20.1)
Ground Line	kg	*4610	*4610	*3200	*3200	*2650	2270	2270	1570	1650	1100	5.92 (19.4)
-1.0m (-5ft)	kg	*2320	*2320	2160	1430	1380	930	980	680	1700	1120	5.46 (17.9)
-1.0m (-5ft)	kg	*5110	*5110	4760	3150	3040	2050	2160	1460	1700	1120	4.85 (15.5)
-2.0m (-5ft)	kg	*3260	2720	2120	1400	1350	910	970	650	860	580	4.65 (14.8)
-2.0m (-5ft)	kg	*7190	6000	4670	3090	2980	2010	2140	1430	1900	1280	4.85 (15.5)
-3.0m (-10ft)	kg	*4150	2760	2130	1400	1360	910			1120	760	
-3.0m (-10ft)	kg	*9150	6080	4700	3090	3000	2010			2470	1680	
	lb	*2770	*2770	*1650	1460							
	lb	*6110	*6110	*3640	3220							

NOTES 1. Lifting capacity is based on SAE J1097, ISO 10567. 2. Lifting capacity of the Robex Series does not exceed 75% of tipping load with the machine on firm, level ground or 87% of full hydraulic capacity. 3. The load point is a hook (standard equipment) located on the back of the bucket. 4. (*) indicates load limited by hydraulic capacity.