

POWER SWITCHES CATALOG

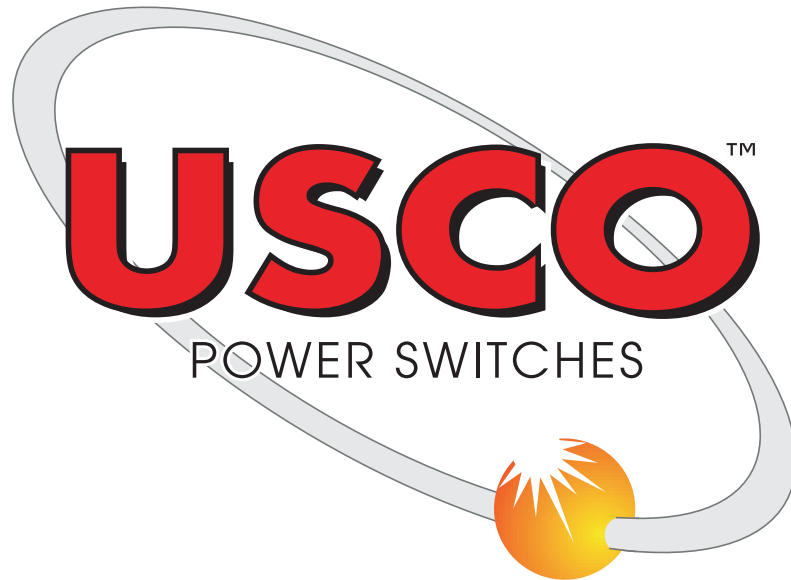

USCO POWER SWITCHES
8100 Churchill Ave., Leeds, Alabama 35094
Telephone (205) 699-0840 Facsimile (205) 699-0858
www.uscopower.com
hpsliterature@hps.hubbell.com
www.hubbellpowersystems.com

NOTE: Because Hubbell has a policy of continuous product improvement, we reserve the right to change design and specifications without notice.

©Copyright 2009 Hubbell Incorporated • 210 North Allen Street • Centralia, MO 65240

Bulletin USCO-6



USCO™
Power Switches

These instructions do not purport to cover all details or variations in equipment, nor to provide for every possible contingency to be met in connection with installation, operation, or maintenance. Should further information be desired or should particular problems arise which are not covered sufficiently for the purchaser's purposes, the matter should be referred to your USCO representative, or direct to the USCO factory.

UNPACKING INSTRUCTIONS

ALL GANG OPERATED SWITCHES (Grounding Switch Not Included)

Each switch consists of three or more packaged items; the control parts box, the switch units, a bundle of pipe and the insulators when not assembled to the switch. Check packing list, attached to the switch crate, to determine if all material has been received. Check insulators carefully for cracked or broken porcelain. Check all other materials for possible shipment damage or loss. Report any claims to the carrier.

7.5 thru 46kV switch units are shipped completely assembled with insulators unless specified otherwise by the purchaser.

69kV thru 230kV switch units are shipped assembled, less insulators, unless specified by the purchaser or switch construction necessitates the complete assembly.

Installation instructions and print of control arrangement are packed in the control parts box in a plastic envelope. Check bill of material on control print and material received. Notify factory of any missing parts.

All switch units have been adjusted at the factory for proper contact pressure, proper opening angle, etc. and no field adjustments of the live parts are required.

Make absolutely sure applicable equipment is de-energized and properly grounded before proceeding with any installation or maintenance.

GUIDE FOR MAINTENANCE OF HIGH VOLTAGE DISCONNECTING SWITCHES ANSI C-37.35 1995

INTRODUCTION

High voltage disconnecting switches are assigned certain ratings and standard test are conducted to assure the user that the switch, when new, will perform within the ratings shown on the nameplate. It should be recognized that the switch in service will perform within these ratings only if properly operated and maintained. It cannot be stressed too strongly that prescribed safety rules should be adhered to at all times when operating or maintaining high voltage disconnecting switches near energized equipment or conductors.



MAINTENANCE

High voltage disconnecting switches are not equipped with isolating devices allowing them to be serviced at frequent intervals. This does not indicate, however, that care or inspection is unnecessary. The frequency of inspection will depend on the atmospheric conditions at a given location, the frequency of operation, etc., and shall be determined by the user. In noncorrosive atmospheres, a switch may operate satisfactorily for many years without attention, while in a severe atmosphere such as encountered at some power plants and industrial sites, maintenance may be required in a matter of months. If it is known that a switch has carried heavy short-circuit current, special efforts should be made to inspect it at the earliest possible time, since the ability of the switch to carry rated load current or fault current may be seriously impaired if the contacts are not properly maintained.

Where periodic maintenance of any kind cannot be made, it should be recognized that the life of the switch may be affected. In this case, when a switch operation is made, it is suggested that the switch be opened and closed several times instead of just once in order to clean the contacts and free the moving parts more effectively. A visual inspection of a switch when wet from rain or snow might indicate hot spots which are possible sources of trouble.

The following recommendations require special consideration:

Be sure that the switch is disconnected from all electric power sources before servicing.

After power has been disconnected from the switch, ground leads to their equivalent should be attached to both sides of the switch. Such grounding may be unnecessary in the case of low voltage switches that can be visibly isolated from energized conductors by other disconnecting means.

Inspect insulators for breaks, cracks, or burns. Clean the insulators where abnormal conditions such as salt deposits, cement dust, or acid fumes prevail. This is necessary to avoid flashover as a result of the accumulation of substance on their surfaces.

Inspect contacts for alignment, pressure, burns, or corrosion. Replace pitted or badly burned contacts. If pitting is of a minor nature, smooth down the surface with clean, **fine sandpaper (not emery)**.

Inspect interphase linkages, operating rods, levers, bearings, etc., to make sure that the adjustments have not changed or that the pipes are not bent. Check for simultaneous closing of all blades and for complete contact in the closed position. Check gearboxes for moisture, which could cause corrosion or difficulty in operating the switch due to ice formation. Inspect flexible braids or slipring commonly used for grounding the operating handle. Replace braids showing signs of corrosion, wear, or broken strands.

Inspect over-all switch for good working conditions. See that bolts, nuts, washers, cotter pins, and terminal connectors are in good condition. Replace items showing excessive wear or corrosion.

When a switch cannot be disconnected from power, hot stick servicing may be used as great an extent as possible.

Power-operating mechanisms attached to high voltage disconnecting switches are usually of the motor-driven, hydraulic, or pneumatic type. The maintenance instructions of the particular manufacturer of each mechanism should be followed. In addition, check limit switch adjustment, associated relay equipment for poor contacts, burned out coils, inadequate supply voltage, and any other conditions that might prevent the proper functioning of the complete switch assembly.



GUIDE FOR OPERATION OF HIGH VOLTAGE DISCONNECTING SWITCHES ANSI C-37.35-1995

INTRODUCTION

High voltage disconnecting switches are assigned certain ratings and standard tests are conducted to assure the user that the switch when new, will perform within the rating shown on the nameplate. It should be recognized that the switch in service will perform within these ratings only if properly operated and maintained. It cannot be stressed too strongly that prescribed safety rules should be adhered to at all times when operating or maintaining high voltage disconnecting switches near energized equipment or conductors.

OPERATION

High Voltage disconnecting switches, grounding switches, and horn gap switches are given no interrupting rating.* The following general rules should be followed:

Prior to operating, check to see that it is fully closed and latched or fully open, as intended.

Switches should be closed rapidly.

After operating a switch, check to see that it is fully closed and latched or fully open, as intended.

Do not use undue force in attempting to operate a switch. The operating mechanism is designed properly for the switch and any undue force, in the nature of an extension of the operating handle, an extra person on the operating handle or switch stick, may cause severe damage to the switch or mechanism. A few sharp raps on the vertical operating pipe or suddenly applied tugs on the operating handle may help to free an iced switch mechanism.

Power-operated switches should be operated periodically to ensure that the switches and their mechanism and control features are functioning properly. Where the circuit conditions will not permit operating the switch energized and the circuit cannot be de-energized for this purpose, it is suggested that arrangements be made to disengage the operating mechanism from the linkage to allow the control circuits and mechanisms to be checked, provided that this method does not adversely affect the over-all adjustment.

* It is common practice to use these devices to interrupt small values of current such as the charging current of a short length of transmission or distribution line, transformer magnetizing current, or light load current. It should be recognized that such operation results in unconfined electric arcs at the switch contacts which under unfavorable conditions may cause damage to the switch, and which may involve adjacent phase conductors or supporting structure in the initiation of system faults. Transfer switching in parallel or loop circuits also has the same attendant hazards. If current interruption is contemplated, care should be taken to be sure that the current magnitude is in a range that can be handled by the switch with a good probability of successful interruption.

REFERENCES

"Interrupting Ability of Horn-gap Switches." American Institute of Electrical Engineers Transactions, vol. 69, 1950, part II, pp. 1016-1027

"Transformer Magnetizing Current and Its Effect on Relaying and Air Break Switch Operation." AIEE Transactions, vol. 70, 1951, part II, pp. 1733-1740.

ANSI C-37.35-1995



WARRANTY INFORMATION

The following designated products sold by the Corporation are warranted to be free of defects in material and workmanship and to remain so under normal and proper use for a period of ten years. These product designations are:

- 1) AGCH-5 all ratings
- 2) AGCH-5V all ratings
- 3) AVR all ratings
- 4) ASB all ratings
- 5) ATR all ratings

All other products sold by the Corporation will carry a standard one-year warranty. Should it become evident that any product under (a) and (b) above proves defective in workmanship or material during its designated warranty limit, upon prompt written notification from the Purchaser, the Corporation shall, at its option, repair or replace the defective part or parts f.o.b. factory freight prepaid by the Purchaser. The Corporation's liability for damages for any claimed defect shall in no event exceed the purchase price of the product. The foregoing warranty is exclusive. All other warranties, whether express or implied or arising by operation of law, course of deal, usage of trade or otherwise are excluded. The only warranties of merchantability and fitness for purpose are those expressed above and **THERE ARE NO IMPLIED WARRANTIES OF MERCHANTABILITY OR FITNESS FOR PURPOSE.** The Corporation shall not be liable for any penalty or for any special or consequential damages, such as loss of profits or revenue, loss of other equipment, down-time costs, costs associated with the removal of the equipment from service or reinstallation or disassembly or reassembly, or for claims of third parties against the Purchaser. The warranty set forth in the first paragraph of this section does not apply to, nor is any expense or other damages or liability assumed for any equipment which has been improperly stored or installed, or from any accidental or intentional attempts to operate it in excess of its rating or in abnormal atmosphere or environments, or to which unauthorized repairs or modifications have been made, even though such equipment is defective and not in accord with the specifications. Any such repairs or modifications must be authorized by the Corporation in writing. The Corporation's responsibility does not extend to equipment, which it did not manufacture.



USCO™
Power Switches

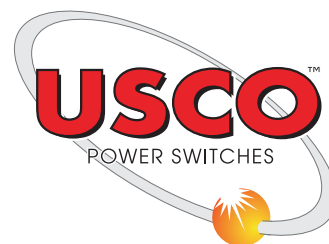

NAMEPLATE INFORMATION

The USCO Nameplate reflects pertinent technical and administrative information pertaining to the product.

A nameplate is located on the base of each switch phase and on the control handle of all group-operated switches.

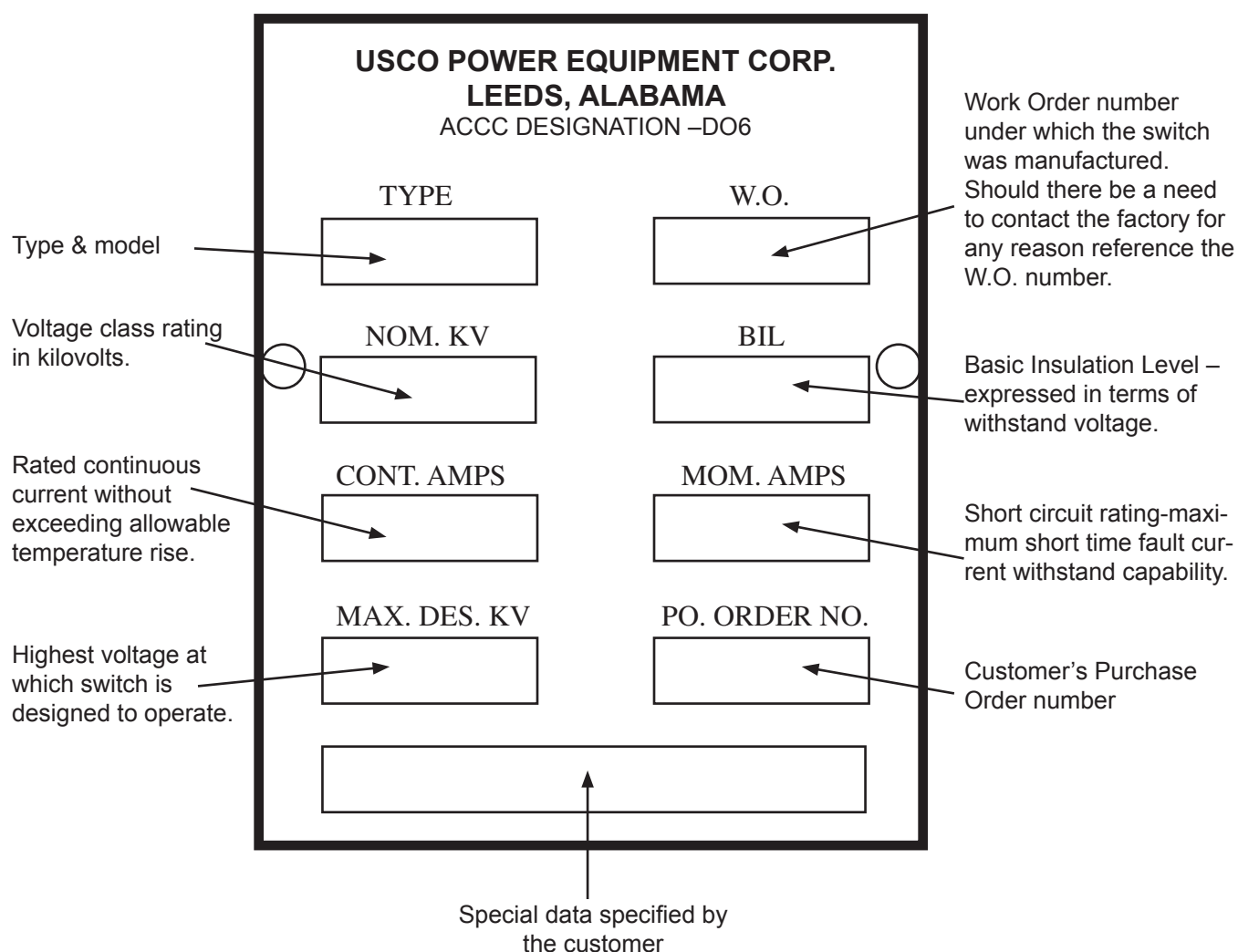

USCO'S STANDARD NAMEPLATE IS ALUMINUM

Revised 11/30/2005



USCO™
Power Switches

CENTER BREAK SWITCH

TYPE AGCH5

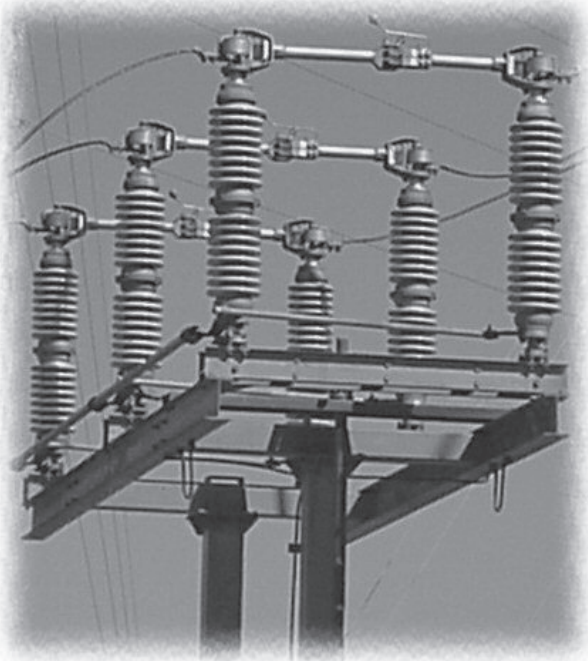

C
E
N
T
E
R

B
R
E
A
K

VOLTAGE RATING

7.5kV to 345kV

CURRENT RATING

1200 to 5500A

AGCH5 Center Break

The **AGCH5** is a two-insulator, side opening outdoor air disconnect switch constructed primarily of aluminum. Operation is accomplished by the rotation of two insulators making the center break switch the easiest operating of all group operated switches. Unique construction methods through years of field experience, coupled with simple design concepts provide ease of installation as well as long-term dependability.

- Welded Lamination Design**
- Low Operating Effort**
- Heavy Duty Rugged Durability**

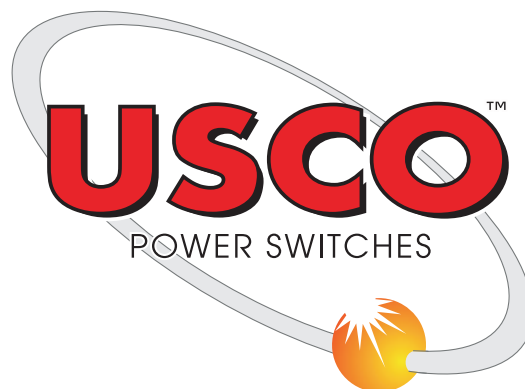

SINCE 1946, THE ENGINEERS CHOICE FOR HIGH VOLTAGE PRODUCTS



USCO™
Power Switches

C
E
N
T
E
R

B
R
E
A
K

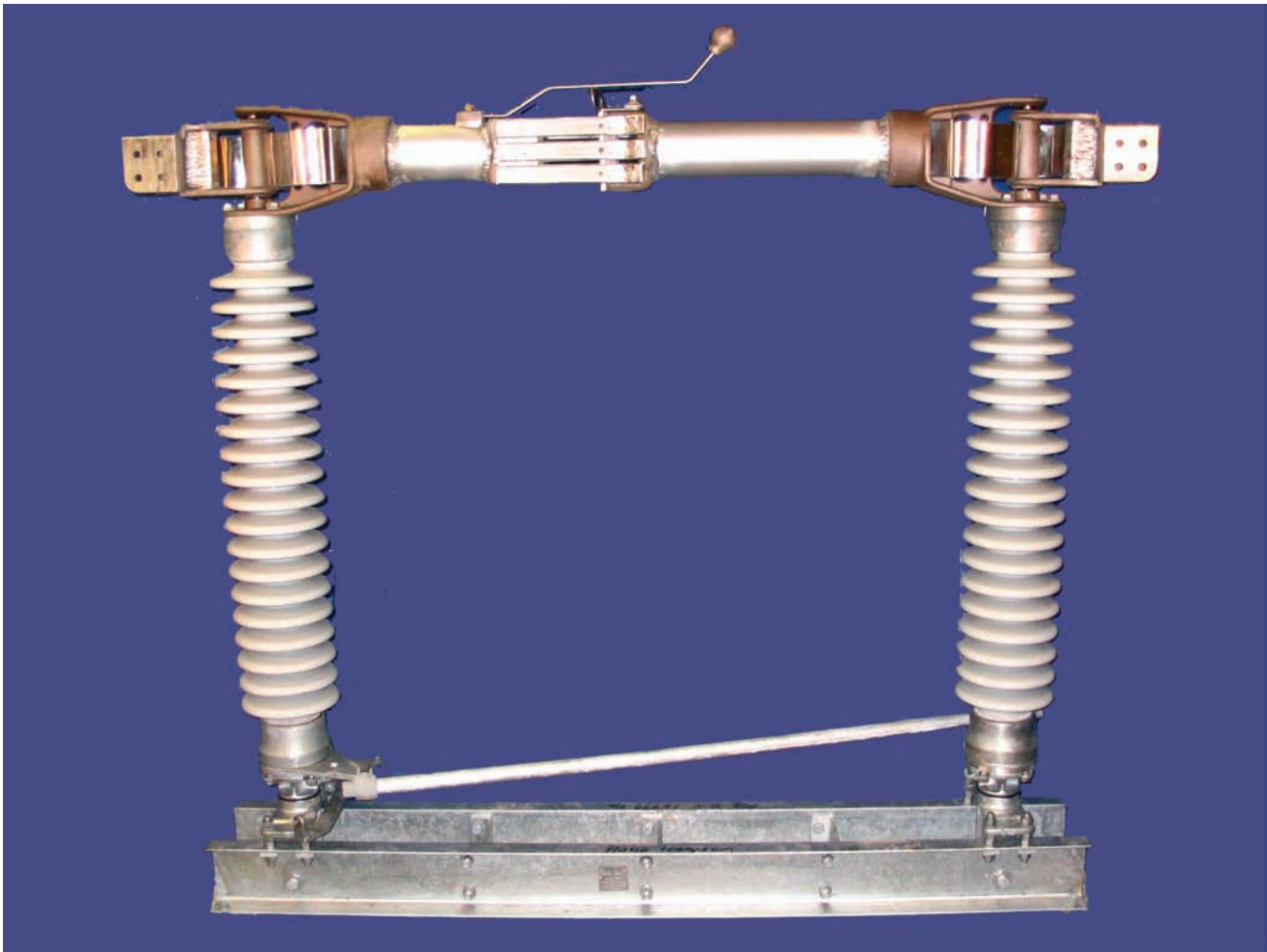

DESCRIPTION

The **AGCH5** is an outdoor, group-operated side opening two insulator, air disconnect switch with both insulators rotating during operation. The **AGCH5** is constructed primarily of aluminum and is available in ratings from 7.5kV through 345kV nominal (8.25kV through 367kV maximum) and 1200 through 5000 continuous amperes. The center break is the easiest operating of all group-operated switches. Mounted horizontal upright or underhung, the blades lift no weight during operation. Mounted vertically, the blades counterbalance each other during operation.

APPLICATION

The **AGCH5** is commonly used in three-phase line or substation applications such as transformer or line disconnecting, breaker isolating, bypassing or bus sectionalizing. Operation of the **AGCH5** may be accomplished by either manual control or by motor operator.

TESTING

The **AGCH5** has been extensively tested to meet or exceed current ANSI standards. A comprehensive test brochure is available outlining electrical and mechanical design test conducted on the **AGCH5**.

DESIGN CHARACTERISTICS



USCO™
Power Switches

Contacts

The **AGCH5** is supplied with line-high pressure silver-to-silver jaw contacts producing the highest conductivity initially and over time.

The contact fingers, fabricated from hard drawn copper, are silver metallized and electro-tin plated. The male contact, also of hard drawn copper, has a brazed silver overlay and is electro-tin plated. These methods and materials used in the application of the silver provide surfaces of differing hardness with anti-galling properties, resulting in minimal wear over years of operation.

All contacts on the **AGCH5** are field replaceable.

The **AGCH5** uses USCO's time tested welded lamination hinge assembly producing a straight-line current path eliminating any current transfer at the hinge. This is accomplished with a welded aluminum laminated conductor that is used to create a bypass at the hinge. This eliminates the need for bolted or sliding pressure connections, or high pressure contacts, and enables ease of operation. The welded connections create a single metallic path from the hinge terminal pads to the main contacts on the blades of the switch. The laminated conductor is constructed of commercially pure aluminum strip, which does not work harden during operation.

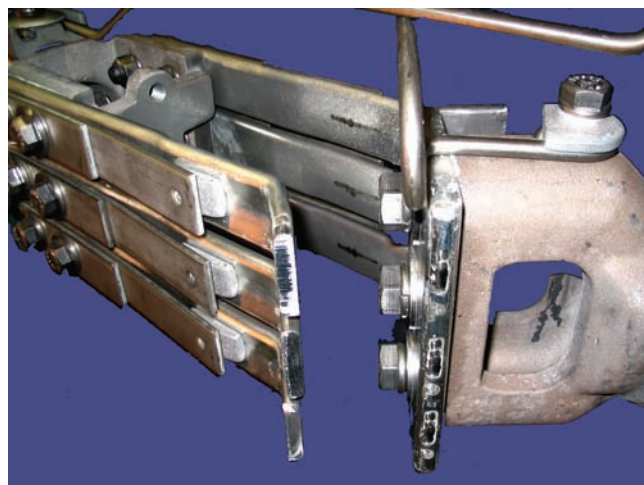

Blade

The blade is constructed of heat-treated aluminum tubing with heat-treated aluminum castings welded to hinge and jaw ends.

Blade Mechanism

The center break design of the **AGCH5** allows for better weight distribution of the blade assemblies providing excellent operational performance. The center break design increases rigidity of the blades while decreasing probability of contact misalignment, especially with higher rated switches. The two insulator configuration decrease cost while providing a simple field friendly installation.

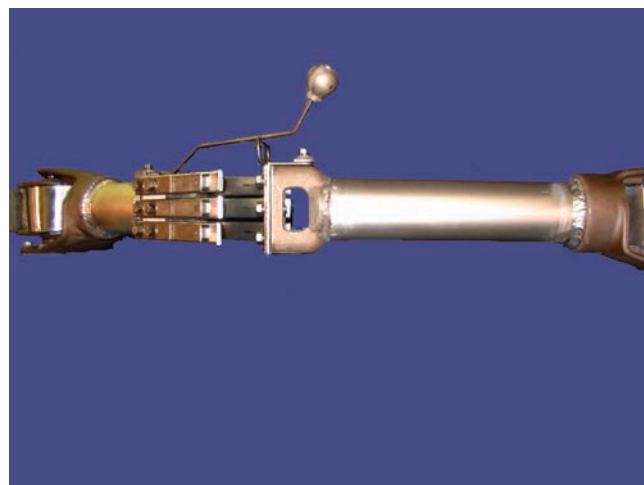

C
E
N
T
E
R

B
R
E
A
K

ACCESSORIES

- Grounding switches: Through 100kA momentary
- Auxiliary switches: Up to 12 contact decks are standard
- Standard arcing horns are installed on all switches
- Outriggers: Custom designed for your application
- Connectors: Available on all switch types



USCO™
Power Switches



Main Switch Bearings

The **AGCH5** incorporates rugged switch bearings consisting of stainless steel balls, utilizing stainless steel bearing races with galvanized ductile iron housings and rotors. The bearings are sealed at the factory for maintenance free service. Factory adjusted stops are provided with the bearing for ease of synchronization during installation. At 345kV and above the main bearing is a Timken roller bearing.

Switch Bases

Hot dipped structural steel channel is used for the construction of the switch base. Leveling studs are provided on the bearings for insulator alignment. Bases and base mounting dimensions can be customized to your specifications and structure.

Insulators

The **AGCH5** is designed to accommodate commercially available insulators with three, five or seven inch bolt circle.

Operating Mechanisms

The **AGCH5** may be operated with a swing handle, gearbox or motor operator. Control arrangements are factory designed and customized to your structure, with all linkage components factory cut to the required dimensions.



Hinge Current Transfer

The **AGCH5** has no hinge contacts; therefore it allows current transfer with maximum reliability.

Transfer of current at the hinge end of the blade is accomplished with a welded aluminum laminated conductor, precisely formed and assembled to give thousands of trouble-free operations. This eliminates bolted or sliding pressure connections, threaded joints or high-pressure contacts, enabling ease of operation. Welded connections create a single conductive metallic path from the hinge terminal pad to the jaw end of the blade.

The laminated conductor is constructed of commercially pure aluminum strip, which does not work harden during operation. Extensive mechanical, electrical, and environmental testing along with years of field experience, prove this approach to current transfer superior to any conventional enclosed or open-hinge contact design.

CENTER BREAK SWITCH

TYPE AGCH5

7.5 - 46 kV

1200 - 6000 Amperes



USCO™
Power Switches

CATALOG NO.	RATINGS				DIMENSIONS				STD MTG	WEIGHT 1 Pole
	NOM	BIL	CONT.	MOM.	A	B	C	D		
AGCH5-00712	7.5	95	1200	61,000	24	17 7/8	26 1/8	20 7/8	8 1/4 X 24	96
AGCH5-00720	7.5	95	2000	100,000	24	17 7/8	27 1/2	20 7/8	8 1/4 X 24	118
AGCH5-00730	7.5	95	3000	120,000	24	26 1/2	34 1/2	18 1/4	8 1/4 X 24	125
AGCH5-00740	7.5	95	4000	120,000	27	33 1/8	42 5/8	19	8 1/4 X 27	140
AGCH5-00750	7.5	95	5000	120,000	*	*	*	*	*	*
AGCH5-00760	7.5	95	6000	120,000	*	*	*	*	*	*
AGCH5-01512	15	110	1200	61,000	24	20 3/8	28 5/8	20 7/8	8 1/4 X 24	102
AGCH5-01520	15	110	2000	100,000	24	20 3/8	30	20 7/8	8 1/4 X 24	131
AGCH5-01530	15	110	3000	120,000	24	28 1/2	36 1/2	18 1/4	8 1/4 X 24	140
AGCH5-01540	15	110	4000	120,000	27	35 1/8	44 5/8	19	8 1/4 X 27	156
AGCH5-01550	15	110	5000	120,000	*	*	*	*	*	*
AGCH5-01560	15	110	6000	120,000	*	*	*	*	*	*
AGCH5-02312	23	150	1200	61,000	24	24 3/8	32 5/8	20 7/8	8 1/4 X 24	112
AGCH5-02320	23	150	2000	100,000	24	24 3/8	34	20 7/8	8 1/4 X 24	141
AGCH5-02330	23	150	3000	120,000	24	31 1/2	39 1/2	18 1/4	8 1/4 X 24	150
AGCH5-02340	23	150	4000	120,000	27	38 1/8	47 5/8	19	8 1/4 X 27	194
AGCH5-02350	23	150	5000	120,000	*	*	*	*	*	*
AGCH5-02360	23	150	6000	120,000	*	*	*	*	*	*
AGCH5-03412	34.5	200	1200	61,000	24	28 3/8	36 5/8	20 7/8	8 1/4 X 24	168
AGCH5-03420	34.5	200	2000	100,000	24	28 3/8	38	20 7/8	8 1/4 X 24	235
AGCH5-03430	34.5	200	3000	120,000	27	36 1/2	40	21 1/4	8 1/4 X 27	250
AGCH5-03440	34.5	200	4000	120,000	27	43 1/8	52 5/8	19	8 1/4 X 27	265
AGCH5-04612	46	250	1200	61,000	30	32 3/8	40 5/8	22 1/8	8 1/4 X 30	204
AGCH5-04620	46	250	2000	100,000	30	32 3/8	42	22 1/8	8 1/4 X 30	274
AGCH5-04630	46	250	3000	120,000	*	*	*	*	*	*
AGCH5-04640	46	250	4000	120,000	*	*	*	*	*	*

* Refer to Factory

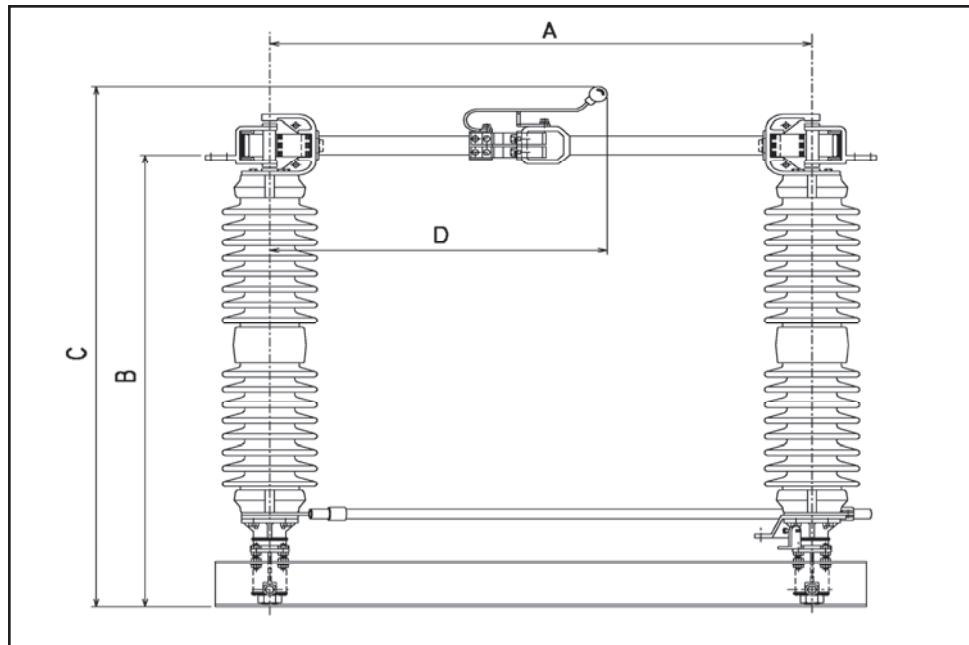

DIMENSIONS SHOWN IN INCHES - WEIGHT SHOWN IN POUNDS (INSULATORS INCLUDED)

7.5 - 46 kV 3" BOLT CIRCLE STATION POST INSULATORS

DIMENSIONS NOT FOR CONSTRUCTION PURPOSES

CONTACT FACTORY FOR CERTIFIED PRINTS

HUBBELL / USCO - LEEDS, ALABAMA USA

JANUARY 2009



USCO™
Power Switches

CENTER BREAK SWITCH

TYPE AGCH5

69 - 345 kV

1200 - 5500 Amperes

CATALOG NO.	RATINGS				DIMENSIONS				STD MTG	WEIGHT 1 Pole
	VOLTAGE (kV)		CURRENT (A)		A	B	C	D		
	NOM	BIL	CONT.	MOM.						
AGCH5-06912	69	350	1200	61,000	42	40 3/8	48 5/8	29 3/4	8 1/4 X 42	320
AGCH5-06920	69	350	2000	100,000	42	40 3/8	48 5/8	29 3/4	8 1/4 X 42	405
AGCH5-06930	69	350	3000	120,000	48	49	45 1/2	32 1/2	8 1/4 X 48	450
AGCH5-06940	69	350	4000	120,000	*	*	*	*	*	495
AGCH5-11512	115	550	1200	61,000	60	60 1/4	69 11/16	37 5/8	8 1/4 x 60	646
AGCH5-11520	115	550	2000	100,000	60	60 1/4	69 7/8	37 5/8	8 1/4 x 60	725
AGCH5-11530	115	550	3000	120,000	60	64	70 1/2	37 1/2	8 1/4 x 60	760
AGCH5-11540	115	550	4000	120,000	60	64 1/8	72 5/8	37 1/4	8 1/4 x 60	810
AGCH5-13812	138	650	1200	61,000	72	69 1/4	78 5/16	43 1/4	8 1/4 x 72	774
AGCH5-13820	138	650	2000	100,000	72	69 1/4	78 3/8	43 1/4	8 1/4 x 72	885
AGCH5-13830	138	650	3000	120,000	72	75	81 1/2	43 1/2	8 3/4 x 72	910
AGCH5-13840	138	650	4000	120,000	72	76 1/8	84 5/8	43 1/4	8 3/4 x 72	940
AGCH5-16112	161	750	1200	61,000	84	80 5/16	89 7/8	48	8 3/4 x 84	950
AGCH5-16120	161	750	2000	100,000	84	80 5/16	90	48	8 3/4 x 84	1100
AGCH5-16130	161	750	3000	120,000	84	84	90 1/2	48 1/4	8 3/4 x 84	1200
AGCH5-16140	161	750	4000	120,000	84	84 1/8	92 5/8	48	8 3/4 x 84	1300
AGCH5-16150	161	750	5000	120,000	84	84 1/8	96 5/8	57	8 3/4 x 84	1410
AGCH5-23012	230	900	1200	61,000	96	98 1/2	112 1/2	57 1/2	8 3/4 x 96	1765
AGCH5-23020	230	900	2000	100,000	96	98 1/2	113 1/2	58	8 3/4 x 96	1820
AGCH5-23030	230	900	3000	120,000	96	102 1/4	114 1/8	56	8 3/4 x 96	1920
AGCH5-23040	230	900	4000	120,000	96	101 1/4	112	59	8 3/4 x 96	1970
AGCH5-23050	230	900	5000	120,000	*	*	*	*	*	2065
AGCH5-34520	345	1300	2000	100,000	132	127 1/4	140	80 3/4	11 x 132	1940
AGCH5-34530	345	1300	3000	120,000	132	130 7/8	143	77 5/8	11 x 132	2030
AGCH5-34540	345	1300	4000	120,000	132	131	140	63 1/2	11 x 132	2125
AGCH5-34550	345	1300	5000	120,000	*	*	*	*	*	2235

* Refer to Factory

For 5500 Ampere Switches Consult Factory

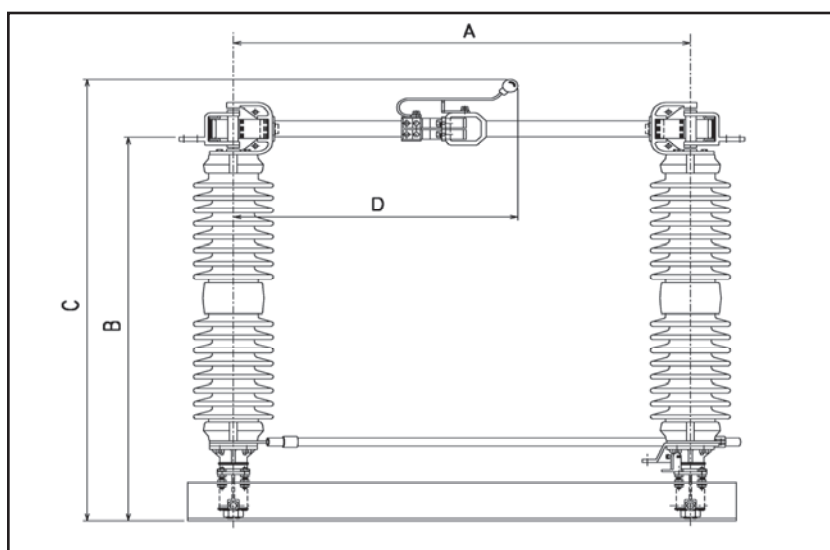

DIMENSIONS SHOWN IN INCHES - WEIGHT SHOWN IN POUNDS (INSULATORS INCLUDED)

7.5 - 69 kV 3" BOLT CIRCLE STATION POST INSULATORS

115 - 345 kV 5" BOLT CIRCLE STATION POST INSULATORS

DIMENSIONS NOT FOR CONSTRUCTION PURPOSES

CONTACT FACTORY FOR CERTIFIED PRINTS

CENTER BREAK SWITCH
TYPES GCH4 & AGCH5
15 - 46 kV



USCO™
Power Switches

CATALOG NO.		RATINGS										
		VOLTAGE (kV)			CURRENT (A)				INS.	BOLT CIRCLE	WEIGHT SINGLE POLE (lbs.)	
COPPER SWITCH	ALUMINUM SWITCH	NOM. (rms)	MAX. (rms)	BIL (peak)	CONT.	PEAK	MOM.	3 SEC.				
GCH4-00712		7.5	8.3	95	1200	99,000	61,000	38,000	TR-202	3"	120	
GCH4-00720		7.5	8.3	95	2000	130,000	80,000	50,000	TR-202	3"	*	
	AGCH5-00712	7.5	8.3	95	1200	99,000	61,000	38,000	TR-202	3"	96	
	AGCH5-00720	7.5	8.3	95	2000	164,000	100,000	62,500	TR-202	3"	118	
	AGCH5-00730	7.5	8.3	95	3000	195,000	120,000	75,000	TR-222	5"	125	
	AGCH5-00740	7.5	8.3	95	4000	195,000	120,000	75,000	TR-222	5"	140	
	AGCH5-00750	7.5	8.3	95	5000	195,000	120,000	75,000	TR-222	5"	*	
	AGCH5-00760	7.5	8.3	95	6000	195,000	120,000	75,000	TR-222	5"	*	
GCH4-01512		15	15.5	110	1200	99,000	61,000	38,000	TR-205	3"	128	
GCH4-01520		15	15.5	110	2000	130,000	80,000	50,000	TR-205	3"	*	
	AGCH5-01512	15	15.5	110	1200	99,000	61,000	38,000	TR-205	3"	102	
	AGCH5-01520	15	15.5	110	2000	164,000	100,000	62,500	TR-205	3"	131	
	AGCH5-01530	15	15.5	110	3000	195,000	120,000	75,000	TR-225	5"	140	
	AGCH5-01540	15	15.5	110	4000	195,000	120,000	75,000	TR-225	5"	156	
	AGCH5-01550	15	15.5	110	5000	195,000	120,000	75,000	TR-225	5"	*	
	AGCH5-01560	15	15.5	110	6000	195,000	120,000	75,000	TR-225	5"	*	
GCH4-02312		23	27.0	150	1200	99,000	61,000	38,000	TR-208	3"	140	
GCH4-02320		23	27.0	150	2000	130,000	80,000	50,000	TR-208	3"	*	
	AGCH5-02312	23	27.0	150	1200	99,000	61,000	38,000	TR-208	3"	112	
	AGCH5-02320	23	27.0	150	2000	164,000	100,000	62,500	TR-208	3"	141	
	AGCH5-02330	23	27.0	150	3000	195,000	120,000	75,000	TR-227	5"	150	
	AGCH5-02340	23	27.0	150	4000	195,000	120,000	75,000	TR-227	5"	194	
	AGCH5-02350	23	27.0	150	5000	195,000	120,000	75,000	TR-227	5"	*	
	AGCH5-02360	23	27.0	150	6000	195,000	120,000	75,000	TR-227	5"	*	
GCH4-03412		34.5	38.0	200	1200	99,000	61,000	38,000	TR-210	3"	210	
GCH4-03420		34.5	38.0	200	2000	130,000	80,000	50,000	TR-210	3"	*	
	AGCH5-03412	34.5	38.0	200	1200	99,000	61,000	38,000	TR-210	3"	168	
	AGCH5-03420	34.5	38.0	200	2000	164,000	100,000	62,500	TR-210	3"	235	
	AGCH5-03430	34.5	38.0	200	3000	195,000	120,000	75,000	TR-231	5"	250	
	AGCH5-03440	34.5	38.0	200	4000	195,000	120,000	75,000	TR-231	5"	265	
GCH4-04612		46	48.3	250	1200	99,000	61,000	38,000	TR-214	3"	255	
GCH4-04620		46	48.3	250	2000	130,000	80,000	50,000	TR-214	3"	*	
	AGCH5-04612	46	48.3	250	1200	99,000	61,000	38,000	TR-214	3"	204	
	AGCH5-04620	46	48.3	250	2000	164,000	100,000	62,500	TR-214	3"	274	
	AGCH5-04630	46	48.3	250	3000	195,000	120,000	75,000	TR-267	5"	315	
	AGCH5-04640	46	48.3	250	4000	195,000	120,000	75,000	TR-267	5"	345	

* Refer to Factory

CENTER BREAK



USCO[™]
Power Switches

CENTER BREAK SWITCH
TYPES GCH4 & AGCH5
69 - 345 kV

CATALOG NO.		RATINGS									
		VOLTAGE (kV)			CURRENT (A)				INS.	BOLT CIRCLE	WEIGHT SINGLE POLE (lbs.)
COPPER SWITCH	ALUMINUM SWITCH	NOM. (rms)	MAX. (rms)	BIL (peak)	CONT.	PEAK	MOM.	3 SEC.			
GCH4-06912		69	72.5	350	1200	99,000	61,000	38,000	TR-216	3"	380
GCH4-06920		69	72.5	350	2000	164,000	100,000	62,500	TR-216	3"	*
	AGCH5-06912	69	72.5	350	1200	99,000	61,000	38,000	TR-216	3"	320
	AGCH5-06920	69	72.5	350	2000	164,000	100,000	62,500	TR-278	5"	405
	AGCH5-06930	69	72.5	350	3000	195,000	120,000	75,000	TR-278	5"	450
	AGCH5-06940	69	72.5	350	4000	195,000	120,000	75,000	TR-278	5"	495
GCH4-11512		115	123	550	1200	99,000	61,000	38,000	TR-286	5"	760
GCH4-11520		115	123	550	2000	164,000	100,000	62,500	TR-286	5"	*
	AGCH5-11512	115	123	550	1200	99,000	61,000	38,000	TR-286	5"	646
	AGCH5-11520	115	123	550	2000	164,000	100,000	62,500	TR-286	5"	725
	AGCH5-11530	115	123	550	3000	195,000	120,000	75,000	TR-286	5"	760
	AGCH5-11540	115	123	550	4000	195,000	120,000	75,000	TR-286	5"	810
GCH4-13812		138	145	650	1200	99,000	61,000	38,000	TR-288	5"	860
GCH4-13820		138	145	650	2000	164,000	100,000	62,500	TR-288	5"	*
	AGCH5-13812	138	145	650	1200	99,000	61,000	38,000	TR-288	5"	774
	AGCH5-13820	138	145	650	2000	164,000	100,000	62,500	TR-288	5"	885
	AGCH5-13830	138	145	650	3000	195,000	120,000	75,000	TR-288	5"	910
	AGCH5-13840	138	145	650	4000	195,000	120,000	75,000	TR-288	5"	940
	AGCH5-16112	161	170	750	1200	99,000	61,000	38,000	TR-291	5"	950
	AGCH5-16120	161	170	750	2000	164,000	100,000	62,500	TR-291	5"	1100
	AGCH5-16130	161	170	750	3000	195,000	120,000	75,000	TR-291	5"	1200
	AGCH5-16140	161	170	750	4000	195,000	120,000	75,000	TR-291	5"	1300
	AGCH5-16150	161	170	750	5000	195,000	120,000	75,000	TR-291	5"	1410
	AGCH5-23012	230	245	900	1200	99,000	61,000	38,000	TR-304	5"	1765
	AGCH5-23020	230	245	900	2000	164,000	100,000	62,500	TR-304	5"	1820
	AGCH5-23030	230	245	900	3000	195,000	120,000	75,000	TR-304	5"	1920
	AGCH5-23040	230	245	900	4000	195,000	120,000	75,000	TR-304	5"	1970
	AGCH5-23050	230	245	900	5000	195,000	120,000	75,000	TR-304	5"	2065
	AGCH5-34520	345	362	1300	2000	164,000	100,000	62,500	TR-367	5"	1940
	AGCH5-34530	345	362	1300	3000	195,000	120,000	75,000	TR-367	5"	2030
	AGCH5-34540	345	362	1300	4000	195,000	120,000	75,000	TR-367	5"	2125
	AGCH5-34550	345	362	1300	5000	195,000	120,000	75,000	TR-367	5"	2235

* Refer to Factory

For 5500 Ampere Switches Consult Factory



USCO™
Power Switches

DOUBLE CENTER BREAK SWITCH

TYPE ATR



VOLTAGE RATING
CURRENT RATING

138kV to 500kV
2000 to 4000A

ATR Double Center Break

The **ATR** is a three insulator, double center break outdoor air disconnect switch constructed primarily of aluminum. Operation is accomplished by the rotation of the center insulator. Proven by years of field experience, this switch takes full advantage of unique construction methods to provide both simple operation and long-term dependability.

- Extremely Low Operating Effort
- Superior Under Icing Conditions
- Center Break Ease Of Operation on Vertical Break Phase Spacing

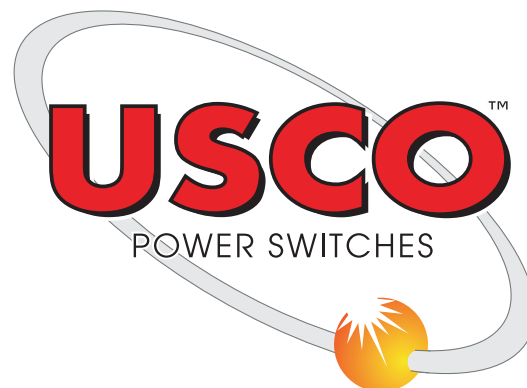

DOUBLE
CENTER
BREAK

SINCE 1946, THE ENGINEERS CHOICE FOR HIGH VOLTAGE PRODUCTS



USCO™
Power Switches



DOUBLE
CENTER
BREAK

DESCRIPTION

The **ATR** is a three-insulator double center break, outdoor, air disconnect switch constructed primarily of aluminum; available in ratings from 138kV through 500kV nominal (145kV through 550kV maximum) at 2000 and 3000 continuous amperes. This unique design incorporates triple insulator rotation for better weight distribution along with our “tried and true” center break blade contact assembly found on our AGCH5 unit.

APPLICATION

The **ATR** is commonly used in three-phase line or substation applications such as transformer or line disconnecting, breaker isolating, bypassing or bus sectionalizing. Operation of the **ATR** may be accomplished by either manual control or by motor operator.

TESTING

The **ATR** has been extensively tested to meet or exceed current ANSI standards. A comprehensive test brochure is available outlining electrical and mechanical design test conducted on the **ATR**.

DESIGN CHARACTERISTICS



USCO™
Power Switches

Contacts

The **ATR** is supplied with high-pressure silver-to-silver jaw contacts producing the highest conductivity initially and over time.

The contact fingers, fabricated from hard drawn copper, are silver metallized and electro-tin plated. The male contact, also of hard drawn copper, has a brazed silver overlay and is electro-tin plated. These methods and materials used in the application of the silver provide surfaces of differing hardness with anti-galling properties, resulting in minimal wear over years of operation.

All contacts on the **ATR** are field replaceable.

The **ATR** uses USCO's time tested welded lamination hinge assembly producing a straight-line current path eliminating any current transfer at the hinge. This is accomplished with a welded aluminum laminated conductor that is used to create a bypass at the hinge. This eliminates the need for bolted or sliding pressure connections, or high pressure contacts, and enables ease of operation. The welded connections create a single metallic path from the hinge terminal pads to the main contacts on the blades of the switch. The laminated conductor is constructed of commercially pure aluminum strip, which does not work harden during operation.

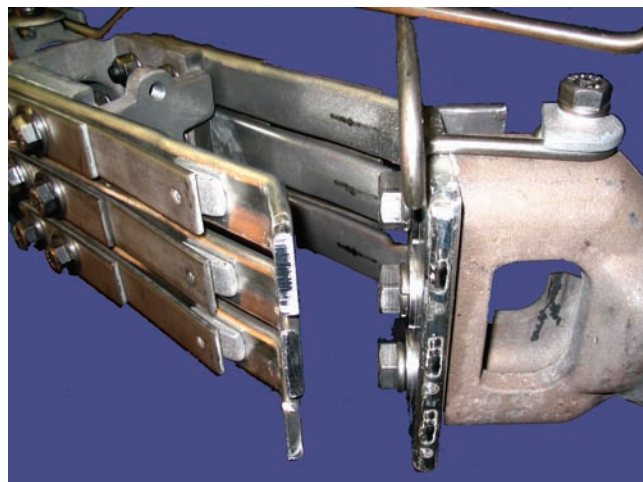

Blade

The blade is constructed of heat-treated aluminum tubing with heat-treated aluminum castings welded to hinge and jaw ends.

Blade Mechanism

The unique center break design of the **ATR** allows for better weight distribution of the blade assemblies without the need for additional phase spacing. The weight of the blades is distributed among the three insulators rather than all the weight balancing on the center insulator, as is the case with the double break switch. This increases rigidity of the blades while decreasing probability of contact misalignment, especially with higher rated switches.



ACCESSORIES

- Grounding switches: Through 100kA momentary
- Auxiliary switches: 12 contact decks are standard
- Standard arcing horns are installed on all group operated switches
- Outriggers: Custom designed for your application
- Connectors: Available on all switch types

DOUBLE
CENTER
BREAK



USCO™
Power Switches

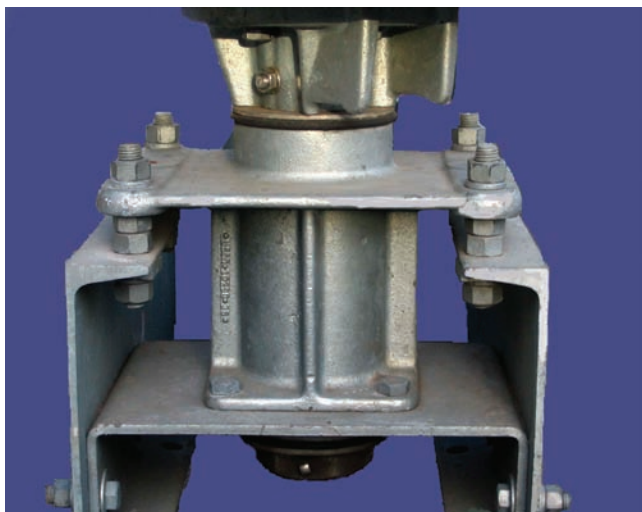

Main Switch Bearings

The **ATR** incorporates rugged switch bearings consisting of stainless steel balls, utilizing stainless steel bearing races (138-230kV) with galvanized ductile iron housings and rotors. The bearings are sealed at the factory for maintenance free service. Factory adjusted stops are provided with the bearing for ease of synchronization during installation. At 345kV and above the main bearing is a Timken roller bearing.

Switch Bases

Hot dipped structural steel channel is used for the construction of the switch base. Leveling studs are provided on the bearings for insulator alignment. Bases and base mounting dimensions can be customized to your specifications and structure.

Insulators

The **ATR** is designed to accommodate commercially available insulators with either five or seven inch bolt circle.

Operating Mechanisms

The **ATR** may be operated with a swing handle, gearbox or motor operator. Control arrangements are factory designed and customized to your structure, with all linkage components factory cut to the required dimensions.



Hinge Current Transfer

The **ATR** has no hinge contacts; therefore it allows current transfer with maximum reliability.

Transfer of current at the hinge end of the blade is accomplished with a welded aluminum laminated conductor, precisely formed and assembled to give thousands of trouble-free operations. This eliminates bolted or sliding pressure connections, threaded joints or high-pressure contacts, enabling ease of operation. Welded connections create a single conductive metallic path from the hinge terminal pad to the jaw end of the blade.

The laminated conductor is constructed of commercially pure aluminum strip, which does not work harden during operation. Extensive mechanical, electrical, and environmental testing along with years of field experience, prove this approach to current transfer superior to any conventional enclosed or open-hinge contact design.

DOUBLE CENTER BREAK SWITCH

TYPE ATR

138 - 500 kV

2000 Amperes



USCO™
Power Switches

CATALOG NO.	RATINGS				DIMENSIONS					STD MTG	WEIGHT 1 Pole
	NOM.	BIL	CONT.	MOM.	A	B	C	D	E		
ATR-13820	138	650	2000	100,000	51	69 5/16	70	34	21 1/4	8 1/4 x 90	*
ATR-16120	161	750	2000	100,000	*	*	*	*	*	8 3/4 x 108	*
ATR-23020	230	900	2000	100,000	60	98 3/8	108 3/16	34 11/16	33 5/8	8 3/4 x 108	2750
ATR-34520-1050	345	1050	2000	100,000	*	*	*	*	*	11 x 150	*
ATR-34520-1300	345	1300	2000	100,000	84	127 1/8	137	49 3/16	42 3/8	11 x 150	*
ATR-50020	500	*	2000	100,000	*	*	*	*	*	*	*

* Refer to Factory

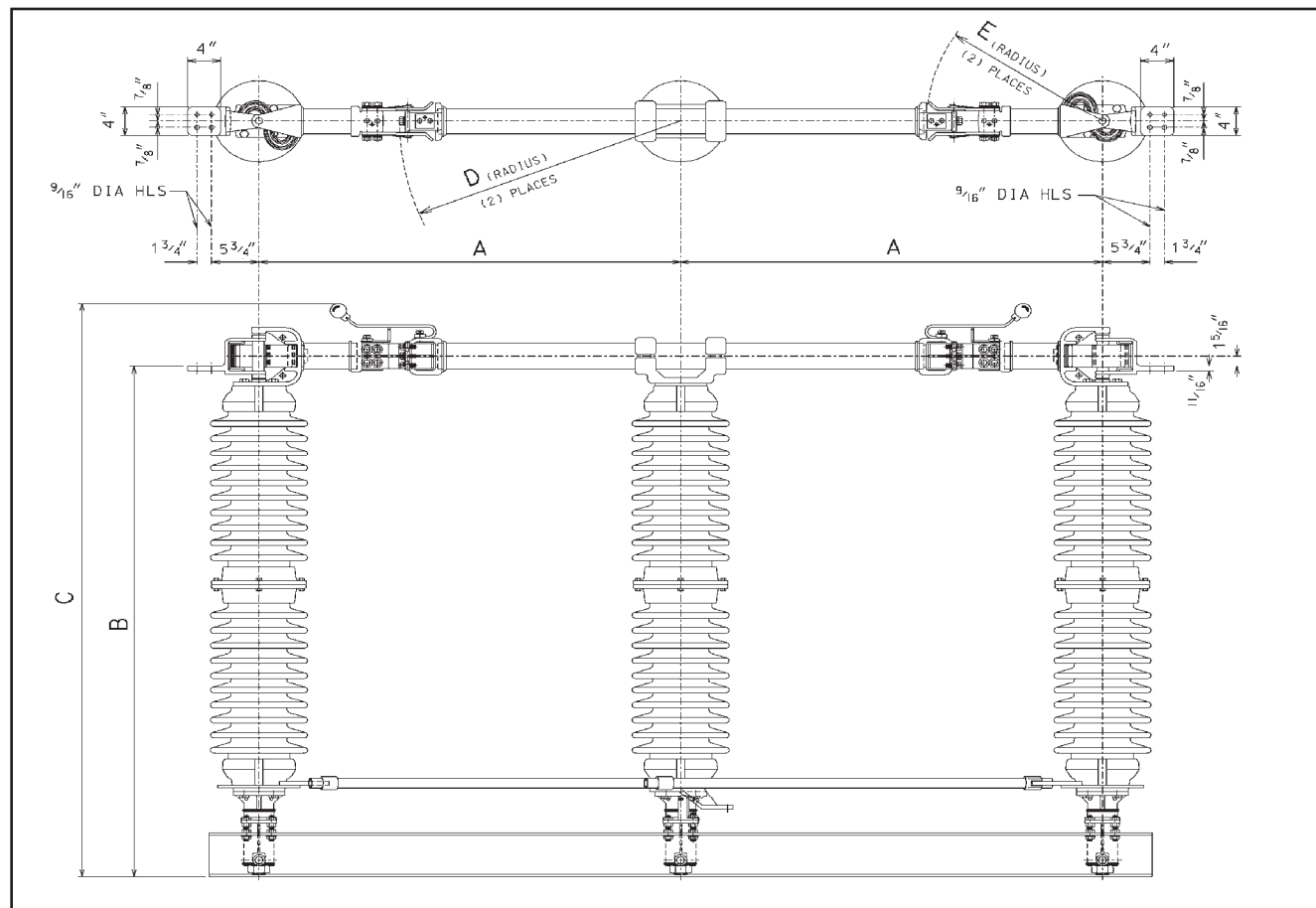

DIMENSIONS SHOWN IN INCHES - WEIGHT SHOWN IN POUNDS (INSULATORS INCLUDED)
 138-500 kV 5" BOLT CIRCLE STATION POST INSULATORS
 DIMENSIONS NOT FOR CONSTRUCTION PURPOSES
 CONTACT FACTORY FOR CERTIFIED PRINTS

DOUBLE
CENTER
BREAK



USCO™
Power Switches

DOUBLE CENTER BREAK SWITCH

TYPE ATR

138 - 500 kV

3000 - 4000 Amperes

CATALOG NO.	RATINGS				DIMENSIONS					STD MTG	WEIGHT 1 Pole
	NOM.	BIL	CONT.	MOM.	A	B	C	D	E		
ATR-13830	138	650	3000	120,000	48	73 7/16	79 5/8	26	26 4/9	8 1/4 x 90	*
ATR-16130	161	750	3000	120,000	60	84 1/2	90 11/16	33 1/2	31 3/4	8 3/4 x 108	*
ATR-23030	230	900	3000	120,000	60	102 3/4	114 5/8	33 1/2	31 3/4	8 3/4 x 108	2850
ATR-34530	345	1050	3000	120,000	84	116 7/8	126 5/8	48 5/8	40 1/2	11 x 150	*
ATR-34530-1300	345	1300	3000	120,000	84	130 7/8	140 11/16	48 5/8	40 1/2	11 x 150	2900
ATR-50030-1550	500	1550	3000	100,000	132	153	162 13/16	96 5/8	40 1/2	11 x 216	4000
ATR-50030-1800	500	1800	3000	100,000	132	177	186 13/16	96 5/8	40 1/2	11 x 216	4250
ATR-50040-1800	500	1800	4000	100,000	132	177	189 7/8	96 11/16	41 3/4	11 x 216	4500

* Refer to Factory

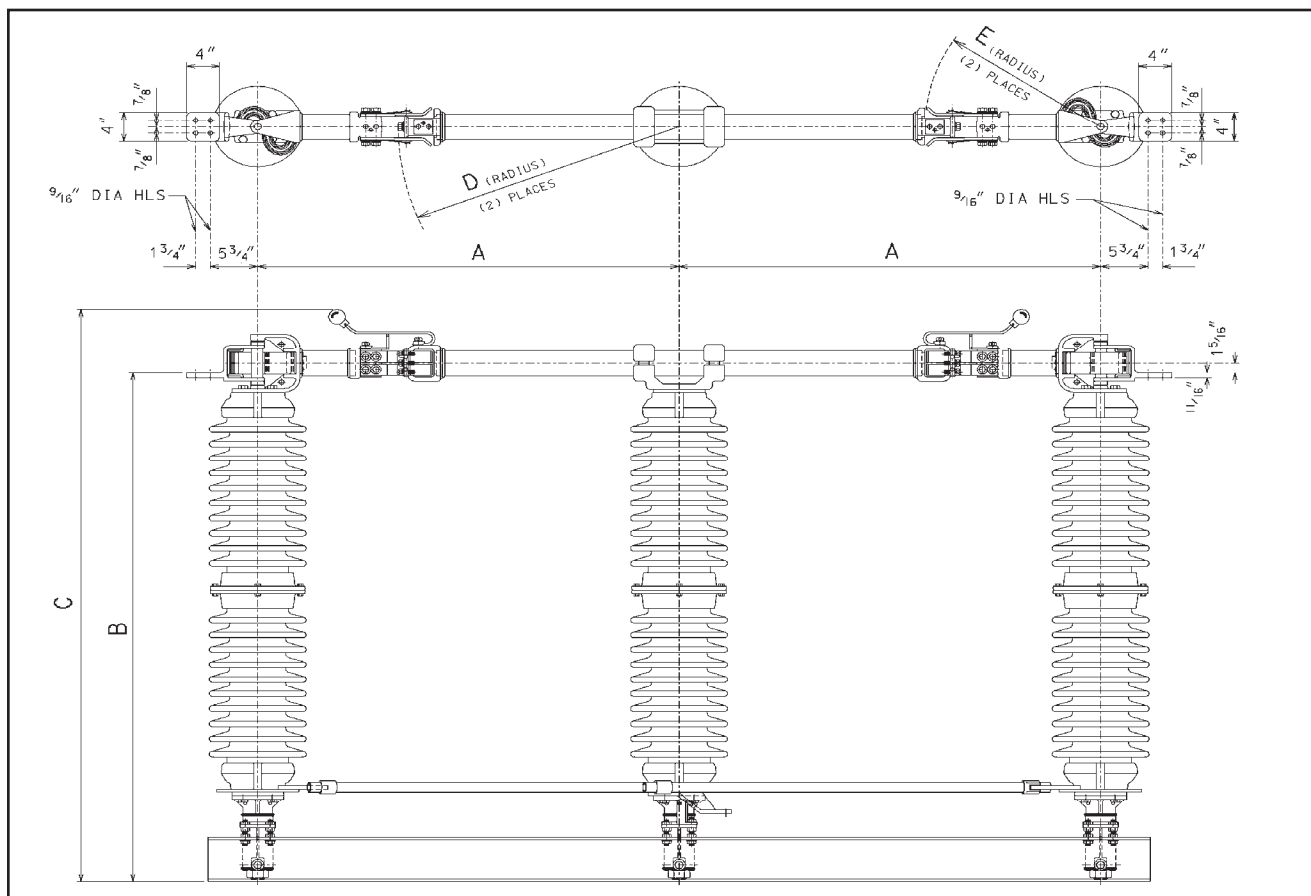

DIMENSIONS SHOWN IN INCHES - WEIGHT SHOWN IN POUNDS (INSULATORS INCLUDED)

138-500 kV 5" BOLT CIRCLE STATION POST INSULATORS

DIMENSIONS NOT FOR CONSTRUCTION PURPOSES

CONTACT FACTORY FOR CERTIFIED PRINTS

DOUBLE
CENTER
BREAK

DOUBLE CENTER BREAK SWITCH
TYPE ATR
138 - 500 kV



USCO™
Power Switches

CATALOG NO.	RATINGS									
	VOLTAGE (kV)			CURRENT (A)				INS.	BOLT CIRCLE	WEIGHT SINGLE POLE (lbs.)
ALUMINUM SWITCH	NOM. (rms)	MAX. (rms)	BIL (peak)	CONT.	PEAK	MOM.	3 SEC.			
ATR13820	138	145	650	2000	164,000	100,000	62,500	TR-288	5"	*
ATR13830	138	145	650	3000	195,000	120,000	75,000	TR-288	5"	*
ATR16120	161	170	750	2000	164,000	100,000	62,500	TR-291	5"	*
ATR16130	161	170	750	3000	195,000	120,000	75,000	TR-291	5"	*
ATR23020	230	245	900	2000	164,000	100,000	62,500	TR-304	5"	2750
ATR23030	230	245	900	3000	195,000	120,000	75,000	TR-304	5"	2850
ATR34520-1050	345	362	1050	2000	164,000	100,000	62,500	TR-312	5"	*
ATR34520-1300	345	362	1300	2000	164,000	100,000	62,500	TR-324	5"	*
ATR34530-1050	345	362	1050	3000	195,000	120,000	75,000	TR-312	5"	*
ATR34530-1300	345	362	1300	3000	195,000	120,000	75,000	TR-324	5"	2900
ATR50020-1470	500	550	1470	2000	164,000	100,000	62,500	TR-330	5"	*
ATR50030-1550	500	550	1550	3000	164,000	100,000	75,000	TR-379	5"-7"	4000
ATR50030-1800	500	550	1800	3000	164,000	100,000	75,000	TR-391	5"-7"	4250
ATR50040-1800	500	550	1800	4000	164,000	100,000	75,000	TR-391	5"-7"	4500

* Refer to Factory



USCO™
Power Switches

VEE SWITCH TYPE AGCH5V

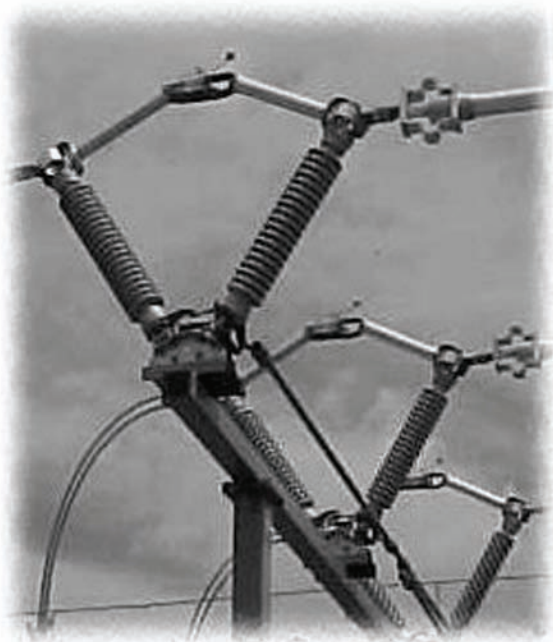

VOLTAGE RATING

15kV to 230kV

CURRENT RATING

1200 to 4000A

AGCH5V Aluminum “V” Center Break

The **AGCH5V** is a two-insulator, side opening outdoor air disconnect switch constructed primarily of aluminum. Operation is accomplished by the rotation of two insulators in a low profile base design. Unique construction methods through years of field experience, coupled with simple design concepts provide ease of installation as well as long-term dependability.

- Welded Lamination Design**
- Low Profile Design**
- Great for Direct Pole Mount Configurations**

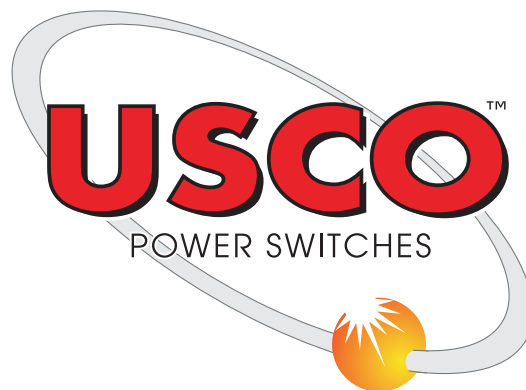

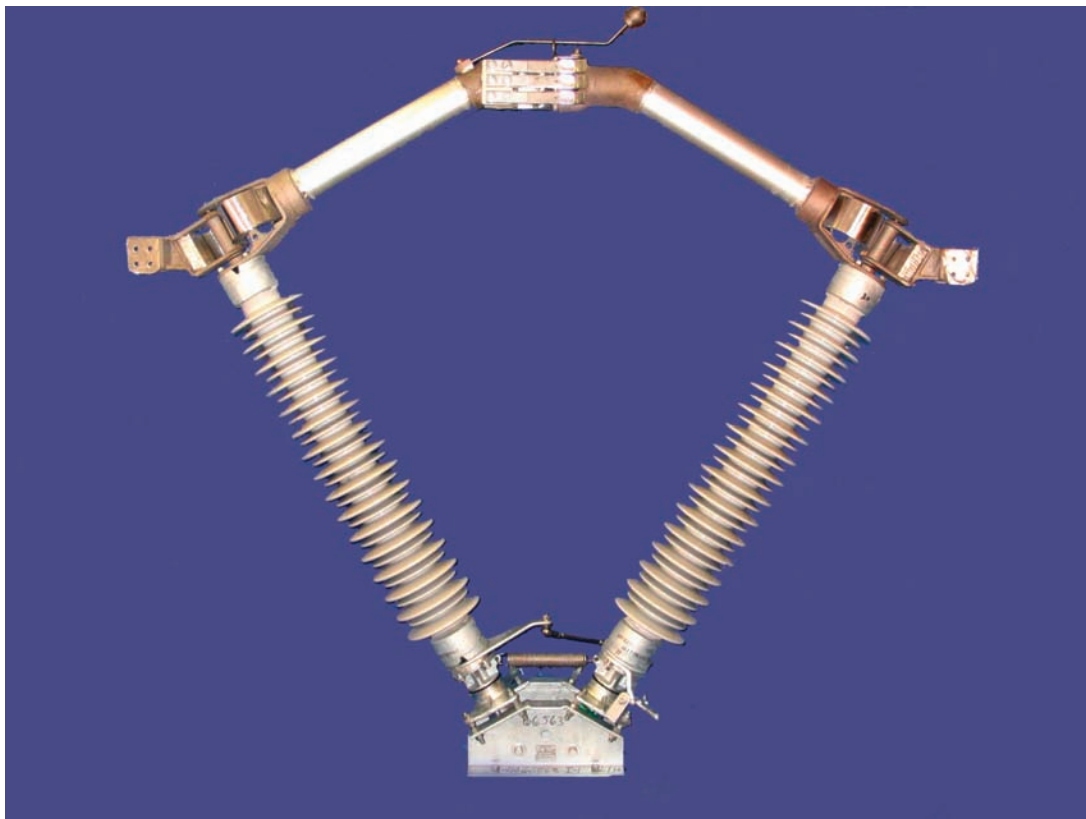

DESCRIPTION

The **AGCH5V** is an outdoor, group-operated side opening two insulator, air disconnect switch with both insulators rotating from a low profile base arrangement.

The **AGCH5V** is constructed primarily of aluminum and is available in ratings from 15kV through 230kV nominal (15.5kV through 242kV maximum) and 1200 through 4000 continuous amperes. The “V” switch maintains the characteristic center break ease of operation while requiring a minimal structure footprint making it versatile for either structure or pole mounted applications.

The low profile design of the **AGCH5V** minimizes structure size creating a more cost effective, aesthetically pleasing switching option. Mounted horizontal upright or underhung, the blades lift no weight during operation. Mounted vertically, the blades counter-balance each other during operation.

APPLICATION

The **AGCH5V** is commonly used in three-phase line or substation applications such as transformer or line disconnecting, breaker isolating, bypassing or bus sectionalizing. The narrow mounting footprint makes the unit versatile for direct pole configurations as well. Operation of the **AGCH5V** may be accomplished by either manual control or by motor operator.

TESTING

The **AGCH5V** has been extensively tested to meet or exceed current ANSI standards. A comprehensive test brochure is available outlining electrical and mechanical design test conducted on the **AGCH5V**.



USCO™
Power Switches

DESIGN CHARACTERISTICS

Contacts

The **AGCH5V** is supplied with line-high pressure silver-to-silver jaw contacts producing the highest conductivity initially and over time.

The contact fingers, fabricated from hard drawn copper, are silver metallized and electro-tin plated. The male contact, also of hard drawn copper, has a brazed silver overlay and is electro-tin plated. These methods and materials used in the application of the silver provide surfaces of differing hardness with anti-galling properties, resulting in minimal wear over years of operation.

All contacts on the **AGCH5V** are field replaceable.

The **AGCH5V** uses USCO's time tested welded lamination hinge assembly producing a straight-line current path eliminating any current transfer at the hinge. This is accomplished with a welded aluminum laminated conductor that is used to create a bypass at the hinge. This eliminates the need for bolted or sliding pressure connections, or high pressure contacts, and enables ease of operation. The welded connections create a single metallic path from the hinge termi-

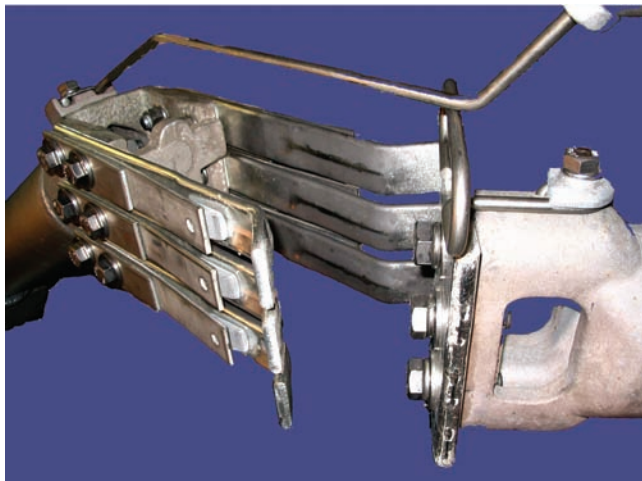

nal pads to the main contacts on the blades of the switch. The laminated conductor is constructed of commercially pure aluminum strip, which does not work harden during operation.

Blade

The blade is constructed of heat-treated aluminum tubing with heat-treated aluminum castings welded to hinge and jaw ends.

Blade Mechanism

The center break design of the **AGCH5V** allows for better weight distribution of the blade assemblies providing excellent operational performance. The center break design increases rigidity of the blades while decreasing probability of contact misalignment, especially with higher rated switches. The two-insulator configuration decreases cost while providing a simple field friendly installation.

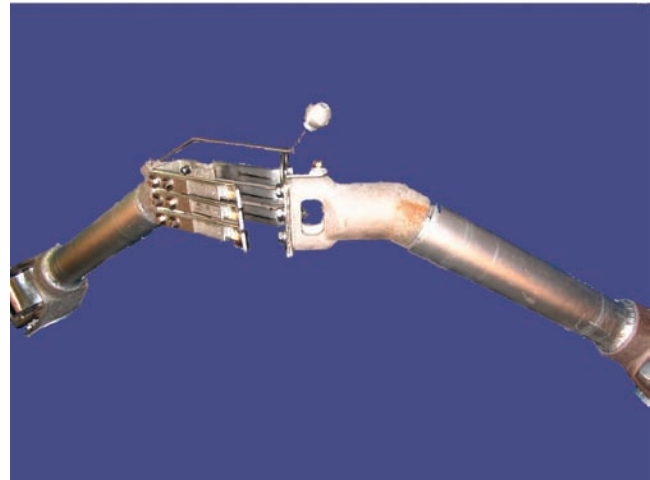

ACCESSORIES

- Grounding switches: Through 100kA momentary
- Auxiliary switches: 12 contact decks are standard
- Standard arcing horns are installed on all group operated switches
- Outriggers: Custom designed for your application
- Connectors: Available on all switch types



USCO™
Power Switches

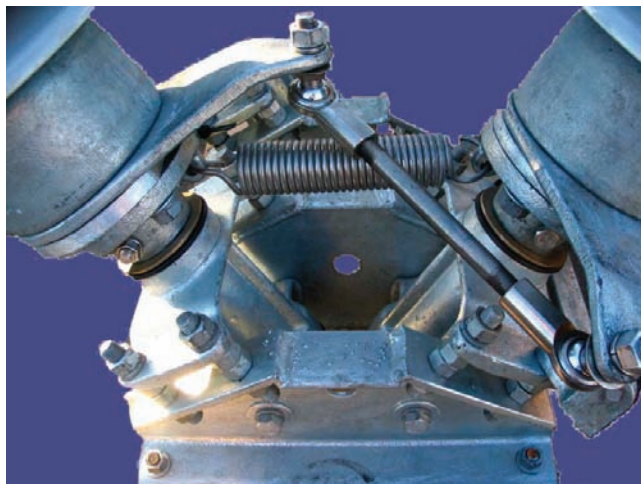

Main Switch Bearings

The **AGCH5V** incorporates rugged switch bearings consisting of stainless steel balls, utilizing stainless steel bearing races with galvanized ductile iron housings and rotors. The bearings are sealed at the factory for maintenance free service. Factory adjusted stops are provided with the bearing for ease of synchronization during installation.

Switch Bases

The stainless steel and bronze linkage mechanism connecting the rotating insulators assures synchronous rotation of the insulators, and positive control of the switch blades during operation. Hot dipped structural steel channel is used for the construction of the switch base. Leveling studs are provided on the bearings for insulator alignment. Bases and base mounting dimensions can be customized to your specifications and structure.

Insulators

The **AGCH5V** is designed to accommodate commercially available insulators with a three or five inch bolt circle.

Operating Mechanisms

The **AGCH5V** may be operated with a swing handle, gearbox or motor operator. Control arrangements are factory designed and customized to your structure, with all linkage components factory cut to the required dimensions.



Hinge Current Transfer

The **AGCH5V** has no hinge contacts; therefore it allows current transfer with maximum reliability.

Transfer of current at the hinge end of the blade is accomplished with a welded aluminum laminated conductor, precisely formed and assembled to give thousands of trouble-free operations. This eliminates bolted or sliding pressure connections, threaded joints or high-pressure contacts enabling ease of operation. Welded connections create a single conductive metallic path from the hinge terminal pad to the jaw end of the blade.

The laminated conductor is constructed of commercially pure aluminum strip, which does not work harden during operation. Extensive mechanical, electrical, and environmental testing along with years of field experience, prove this approach to current transfer superior to any conventional enclosed or open-hinge contact design.



USCO™
Power Switches

VEE SWITCH
TYPE AGCH5V
15 - 46 kV
1200 - 2000 Amperes

CATALOG NO.	RATINGS				DIMENSIONS			STD MTG	WEIGHT 1 Pole
	VOLTAGE (kV)		CURRENT (A)		A	B	C		
	NOM.	BIL	CONT.	MOM.					
AGCH5V-01512	15	110	1200	61,000	37 3/16	10	21 1/2	8 1/4 X 12	102
AGCH5V-01520	15	110	2000	80,000	21 15/16	10	21 7/8	8 1/4 X 12	131
AGCH5V-02312	23	150	1200	61,000	41 3/16	14	25	8 1/4 X 12	112
AGCH5V-02320	23	150	2000	80,000	25 15/16	14	25 3/8	8 1/4 X 12	141
AGCH5V-03412	34.5	200	1200	61,000	29 15/16	18	28 7/16	8 1/4 X 12	160
AGCH5V-03420	34.5	200	2000	80,000	29 15/16	18	28 7/8	8 1/4 X 12	230
AGCH5V-04612	46	250	1200	61,000	33 15/16	22	32	8 1/4 X 12	250
AGCH5V-04620	46	250	2000	80,000	33 15/16	22	32 1/4	8 1/4 X 12	270

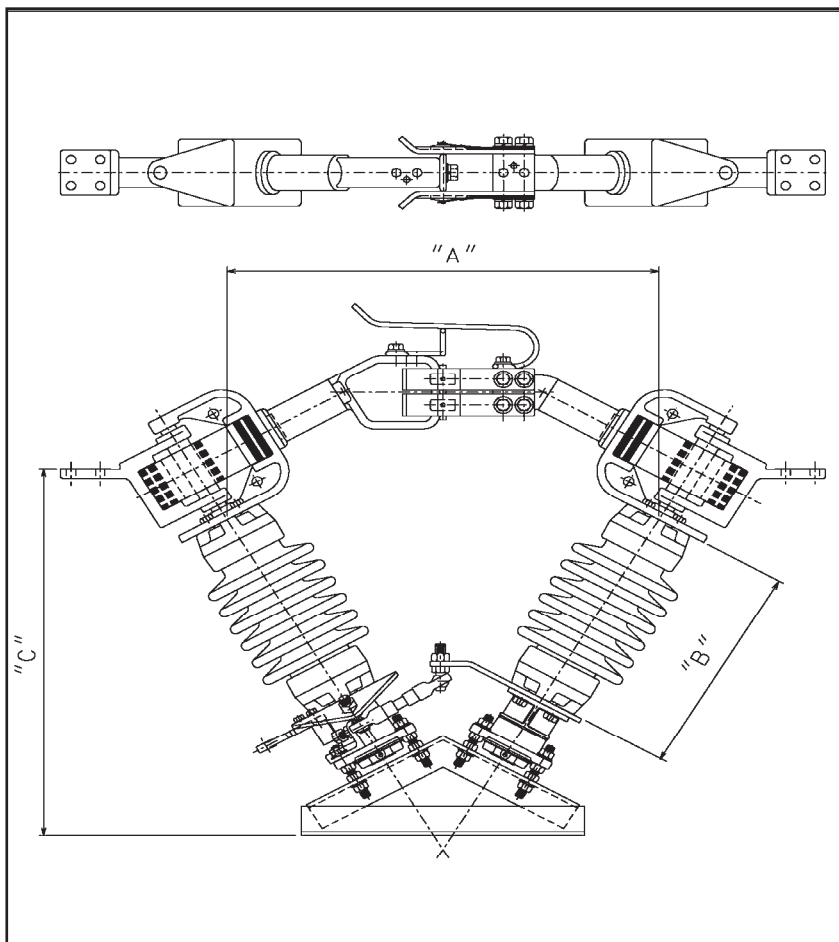

DIMENSIONS SHOWN IN INCHES - WEIGHT SHOWN IN POUNDS (INSULATORS INCLUDED)
15 - 46 kV 3" BOLT CIRCLE STATION POST INSULATORS
DIMENSIONS NOT FOR CONSTRUCTION PURPOSES
CONTACT FACTORY FOR CERTIFIED PRINTS

VEE SWITCH TYPE AGCH5V

69 - 230 kV

1200 - 4000 Amperes



USCO[™]
Power Switches

CATALOG NO.	RATINGS				DIMENSIONS			STD MTG	WEIGHT 1 Pole
	VOLTAGE (kV)		CURRENT (A)		A	B	C		
	NOM.	BIL	CONT.	MOM.					
AGCH5V-06912	69	350	1200	61,000	41 15/16	30	38 7/8	8 1/4 X 12	310
AGCH5V-06920	69	350	2000	80,000	41 15/16	30	39 1/4	8 1/4 X 12	395
AGCH5V-06920-5	69	350	2000	80,000	43 1/2	30	39 13/16	8 1/4 X 12	415
AGCH5V-06920H	69	350	2000	100,000	45 3/4	30	41 1/2	8 1/4 X 12	425
AGCH5V-06930	69	350	3000	120,000	50 1/4	30	41 1/2	8 1/4 X 12	435
AGCH5V-11512	115	550	1200	61,000	76	45	54	8 1/4 X 12	630
AGCH5V-11520	115	550	2000	100,000	82	45	54 1/2	8 1/4 X 12	710
AGCH5V-11530	115	550	3000	120,000	83 1/4	45	54 1/2	8 1/4 X 12	750
AGCH5V-11540	115	550	4000	120,000	81 1/2	45	54 1/2	8 1/4 X 12	810
AGCH5V-13812	138	650	1200	61,000	85	54	61 7/8	8 1/4 X 18	768
AGCH5V-13820	138	650	2000	100,000	91	54	62 1/4	8 1/4 X 18	860
AGCH5V-13830	138	650	3000	120,000	96	54	64 7/16	8 1/4 X 18	905
AGCH5V-13840	138	650	4000	120,000	94 1/4	54	64 7/16	8 1/4 X 18	965
AGCH5V-16112	161	750	1200	61,000	96 3/4	62	71	8 1/4 X 18	935
AGCH5V-16120	161	750	2000	100,000	102 3/4	62	71 3/8	8 1/4 X 18	1090
AGCH5V-16130	161	750	3000	120,000	104	62	71 3/8	8 1/4 X 18	1185
AGCH5V-16140	161	750	4000	120,000	102 1/4	62	71 3/8	8 1/4 X 18	1295
AGCH5V-23012	230	900	1200	61,000	117 1/4	80	89 3/4	12 X 24	1750
AGCH5V-23020	230	900	2000	100,000	119 1/4	80	90 3/16	12 X 24	1805
AGCH5V-23030	230	900	3000	120,000	122 3/4	80	90 1/4	12 X 24	1910
AGCH5V-23040	230	900	4000	120,000	122 3/4	80	90 3/16	12 X 24	2115

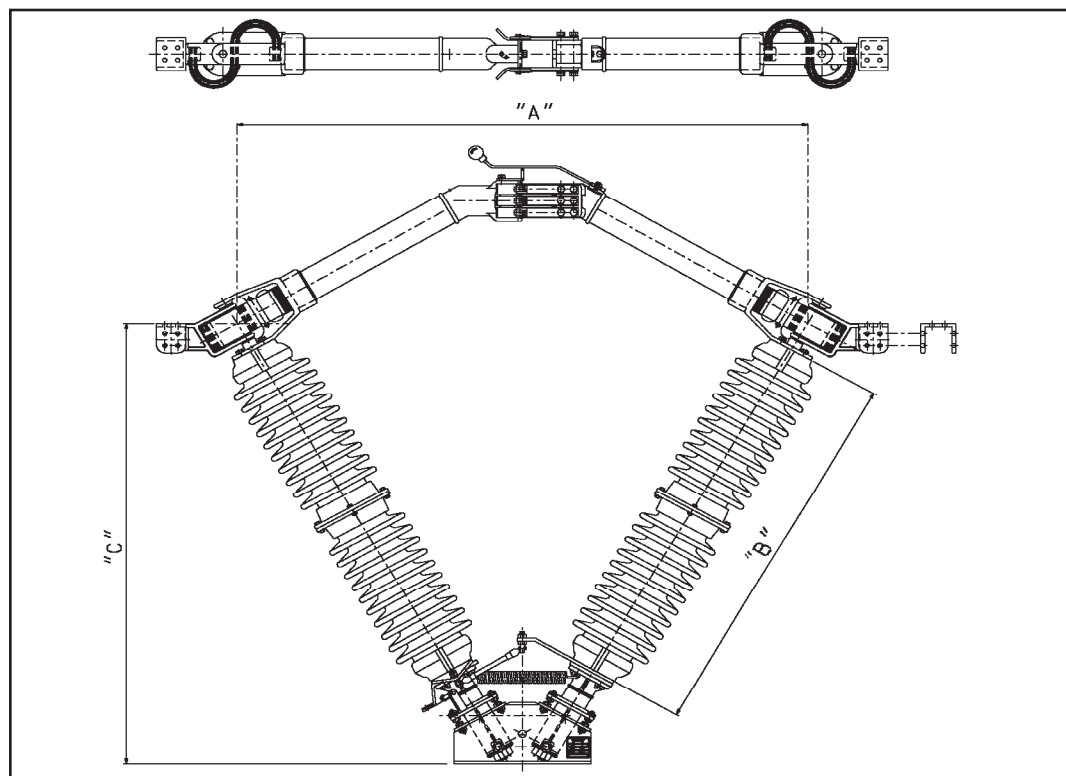

DIMENSIONS SHOWN IN INCHES - WEIGHT SHOWN IN POUNDS (INSULATORS INCLUDED)

15 - 69 kV 3" BOLT CIRCLE STATION POST INSULATORS

69 - 230 kV 5" BOLT CIRCLE STATION POST INSULATORS

DIMENSIONS NOT FOR CONSTRUCTION PURPOSES

CONTACT FACTORY FOR CERTIFIED PRINTS



USCO™
Power Switches

VEE SWITCH
TYPES GCH4V & AGCH5V
15 - 46 kV

CATALOG NO.		RATINGS							INS.	BOLT CIRCLE	WEIGHT SINGLE POLE (lbs.)
		VOLTAGE (kV)			CURRENT (A)						
COPPER SWITCH	ALUMINUM SWITCH	NOM. (rms)	MAX. (rms)	BIL (peak)	CONT.	PEAK	MOM.	3 SEC.			
GCH4V-01512		15	15.5	110	1200	99,000	61,000	38,000	TR-205	3"	128
GCH4V-01520		15	15.5	110	2000	130,000	80,000	50,000	TR-205	3"	*
	AGCH5V-01512	15	15.5	110	1200	99,000	61,000	38,000	TR-205	3"	102
	AGCH5V-01520	15	15.5	110	2000	130,000	80,000	50,000	TR-205	3"	131
GCH4V-02312		23	27.0	150	1200	99,000	61,000	38,000	TR-208	3"	140
GCH4V-02320		23	27.0	150	2000	130,000	80,000	50,000	TR-208	3"	*
	AGCH5V-02312	23	27.0	150	1200	99,000	61,000	38,000	TR-208	3"	112
	AGCH5V-02320	23	27.0	150	2000	130,000	80,000	50,000	TR-208	3"	141
GCH4V-03412		34.5	38.0	200	1200	99,000	61,000	38,000	TR-210	3"	205
GCH4V-03420		34.5	38.0	200	2000	130,000	80,000	50,000	TR-210	3"	*
	AGCH5V-03412	34.5	38.0	200	1200	99,000	61,000	38,000	TR-210	3"	160
	AGCH5V-03420	34.5	38.0	200	2000	130,000	80,000	50,000	TR-210	3"	230
GCH4V-04612		46	48.3	250	1200	99,000	61,000	38,000	TR-214	3"	250
GCH4V-04620		46	48.3	250	2000	130,000	80,000	50,000	TR-214	3"	*
	AGCH5V-04612	46	48.3	250	1200	99,000	61,000	38,000	TR-214	3"	200
	AGCH5V-04620	46	48.3	250	2000	130,000	80,000	50,000	TR-214	3"	270
	AGCH5V-04630	46	48.3	250	3000	164,000	100,000	62,500	TR-267	5"	*

* Refer to Factory

VEE SWITCH
TYPES GCH4V & AGCH5V
69 - 230 kV



USCO™
Power Switches

CATALOG NO.		RATINGS									
		VOLTAGE (kV)			CURRENT (A)				INS.	BOLT CIRCLE	WEIGHT SINGLE POLE (lbs.)
COPPER SWITCH	ALUMINUM SWITCH	NOM. (rms)	MAX. (rms)	BIL (rms)	CONT.	PEAK	MOM.	3 SEC.			
GCH4V-06912		69	72.5	350	1200	99,000	61,000	38,000	TR-216	3"	360
GCH4V-06920		69	72.5	350	2000	164,000	100,000	62,500	TR-216	3"	*
	AGCH5V-06912	69	72.5	350	1200	99,000	61,000	38,000	TR-216	3"	310
	AGCH5V-06920	69	72.5	350	2000	130,000	80,000	50,000	TR-216	3"	395
	AGCH5V-06920-5	69	72.5	350	2000	130,000	80,000	50,000	TR-278	5"	415
	AGCH5V-06920H	69	72.5	350	2000	164,000	100,000	62,500	TR-278	5"	425
	AGCH5V-06930	69	72.5	350	3000	195,000	120,000	75,000	TR-278	5"	435
GCH4V-11512		115	123	550	1200	99,000	61,000	38,000	TR-286	5"	740
GCH4V-11520		115	123	550	2000	164,000	100,000	62,500	TR-286	5"	*
	AGCH5V-11512	115	123	550	1200	99,000	61,000	38,000	TR-286	5"	630
	AGCH5V-11520	115	123	550	2000	164,000	100,000	62,500	TR-286	5"	710
	AGCH5V-11530	115	123	550	3000	195,000	120,000	75,000	TR-286	5"	750
	AGCH5V-11540	115	123	550	4000	195,000	120,000	75,000	TR-286	5"	*
GCH4V-13812		138	145	650	1200	99,000	61,000	38,000	TR-288	5"	850
GCH4V-13820		138	145	650	2000	164,000	100,000	62,500	TR-288	5"	*
	AGCH5V-13812	138	145	650	1200	99,000	61,000	38,000	TR-288	5"	768
	AGCH5V-13820	138	145	650	2000	164,000	100,000	62,500	TR-288	5"	860
	AGCH5V-13830	138	145	650	3000	195,000	120,000	75,000	TR-288	5"	905
	AGCH5V-13840	138	145	650	4000	195,000	120,000	75,000	TR-288	5"	940
GCH4V-16112		161	170	750	1200	99,000	61,000	38,000	TR-291	5"	*
GCH4V-16120		161	170	750	2000	164,000	100,000	62,500	TR-291	5"	*
	AGCH5V-16112	161	170	750	1200	99,000	61,000	38,000	TR-291	5"	935
	AGCH5V-16120	161	170	750	2000	164,000	100,000	62,500	TR-291	5"	1090
	AGCH5V-16130	161	170	750	3000	195,000	120,000	75,000	TR-291	5"	1185
	AGCH5V-16140	161	170	750	4000	195,000	120,000	75,000	TR-291	5"	*
	AGCH5V-23012	230	245	900	1200	99,000	61,000	38,000	TR-304	5"	1750
	AGCH5V-23020	230	245	900	2000	164,000	100,000	62,500	TR-304	5"	1805
	AGCH5V-23030	230	245	900	3000	195,000	120,000	75,000	TR-304	5"	1910
	AGCH5V-23040	230	245	900	4000	195,000	120,000	75,000	TR-304	5"	*

* Refer to Factory



USCO™
Power Switches

VERTICAL BREAK SWITCH TYPE AVR

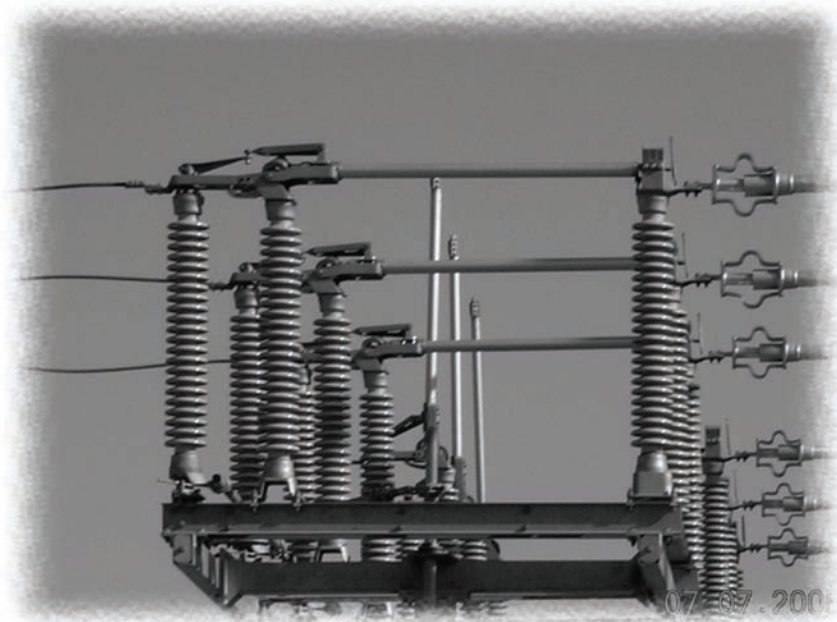

VOLTAGE RATING *7.5kV to 230kV*
CURRENT RATING *1200 to 3000A*

AVR Aluminum Vertical Break

The **AVR** is a three insulator, vertical break outdoor air disconnect switch constructed primarily of aluminum. Operation is accomplished by rotation of the rear insulator. Unique construction methods proven through years of field experience, coupled with simple design concepts provide ease of operation.

- Operation Minimizes Phase Spacing**
- Welded Lamination Design**
- Reverse Loop Contacts For Short Circuit Withstand**
- Great For Interrupting Duty Applications**

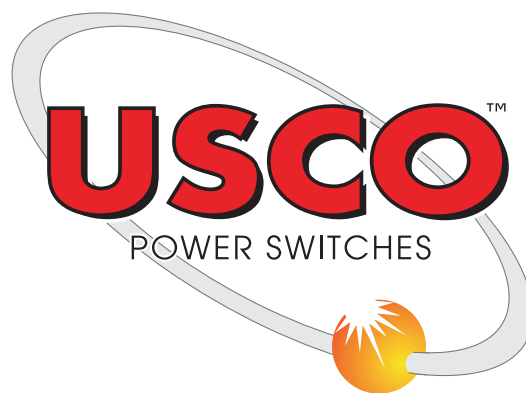

SINCE 1946, THE ENGINEERS CHOICE FOR HIGH VOLTAGE PRODUCTS



DESCRIPTION

The AVR is an outdoor, group-operated vertical opening three insulator, air disconnect switch with the rear insulator rotating during operation. The AVR is constructed primarily of aluminum and is available in ratings from 7.5kV through 230kV nominal (8.25kV through 242kV maximum) and 1200 through 3000 continuous amperes.

APPLICATION

The AVR is commonly used in three-phase line or substation applications such as transformer or line disconnecting, breaker isolating, bypassing or bus sectionalizing. Operation of the AVR may be accomplished by either manual control or by motor operator.

TESTING

The AVR has been extensively tested to meet or exceed current ANSI standards. A comprehensive test brochure is available outlining electrical and mechanical design test conducted on the AVR. The AVR has been extensively tested to meet or exceed current ANSI standards. A comprehensive test brochure is available outlining electrical and mechanical design test conducted on the AVR.



DESIGN CHARACTERISTICS

Contacts

The **AVR** is supplied with reverse loop, silver-to-silver jaw contacts producing the highest conductivity initially and over time.

The contact fingers, fabricated from hard drawn copper, are silver metallized and electro-tin plated. The male contact, also of hard drawn copper, has a brazed silver overlay and is electro-tin plated. These methods and materials used in the application of the silver provide surfaces of differing hardness with anti-galling properties, resulting in minimal wear over years of operation.

All contacts on the **AVR** are field replaceable.

The **AVR** uses USCO's time tested welded lamination hinge assembly producing a straight-line current path eliminating any current transfer at the hinge. This is accomplished with a welded aluminum laminated conductor that is used to create a bypass at the hinge. This eliminates the need for bolted or sliding pressure connections, or high pressure contacts, and enables ease of operation. The welded connections create a single metallic path from the hinge terminal pads to the main contacts on the blades



of the switch. The laminated conductor is constructed of commercially pure aluminum strip, which does not work harden during operation.

Blade

The blade is constructed of heat-treated aluminum tubing with heat-treated aluminum castings welded to hinge and jaw ends.

Blade Mechanism

The blade mechanism of the **AVR** toggles in the closed position locking the switch closed. In the open position, the blade toggles over center. Blade rotation and opening are provided by a sure and simple mechanism designed to operate in adverse conditions. The mechanism is insulated to prevent any welding during fault conditions.



ACCESSORIES

- Grounding switches: Through 100kA momentary
- Auxiliary switches: 12 contact decks are standard
- Standard arcing horns are installed on all group operated switches
- Outriggers: Custom designed for your application
- Connectors: Available on all switch types



USCO™
Power Switches



Main Switch Bearings

The AVR incorporates rugged switch bearings consisting of stainless steel balls, utilizing stainless steel bearing races with galvanized ductile iron housings and rotors. The bearings are sealed at the factory for maintenance free service. Factory adjusted stops are provided with the bearing for ease of synchronization during installation.

Switch Bases

Hot dipped structural steel channel is used for the construction of the switch base. Leveling studs are provided on the bearings for insulator alignment. Bases and base mounting dimensions can be customized to your specifications and structure.

Insulators

The AVR is designed to accommodate commercially available insulators with three, five or seven inch bolt circle.

Operating Mechanisms

The AVR may be operated with a swing handle, gearbox or motor operator. Control arrangements are factory designed and customized to your structure, with all linkage components factory cut to the required dimensions.

Hinge Current Transfer

The AVR has no hinge contacts; therefore it allows current transfer with maximum reliability.



Transfer of current at the hinge end of the blade is accomplished with a welded aluminum laminated conductor, precisely formed and assembled to give thousands of trouble-free operations. This eliminates bolted or sliding pressure connections, threaded joints or high-pressure contacts, enabling ease of operation. Welded connections create a single conductive metallic path from the hinge terminal pad to the jaw end of the blade.

The laminated conductor is constructed of commercially pure aluminum strip, which does not work harden during operation. Extensive mechanical, electrical, and environmental testing along with years of field experience, prove this approach to current transfer superior to any conventional enclosed or open-hinge contact design.



USCO[™]
Power Switches

VERTICAL BREAK SWITCH

TYPE AVR

7.5 - 230 kV

1200 - 2000 Amperes

CATALOG NO.	RATINGS				DIMENSIONS			STD MTG	WEIGHT 1 Pole
	VOLTAGE (kV) NOM.	BIL	CURRENT (A) CONT. MOM.		A	B	C		
AVR-00712	7.5	95	1200	61,000	18	16 3/8	42 1/4	8 1/4 x 36	165
AVR-00720	7.5	95	2000	100,000	18	16 3/8	42 1/4	8 1/4 x 36	172
AVR-01512	15	110	1200	61,000	18	18 7/8	44 3/4	8 1/4 x 36	175
AVR-01520	15	110	2000	100,000	18	18 7/8	44 3/4	8 1/4 x 36	182
AVR-02312	23	150	1200	61,000	21	22 7/8	51 3/4	8 1/4 x 39	210
AVR-02320	23	150	2000	100,000	21	22 7/8	51 3/4	8 1/4 x 39	217
AVR-03412	34.5	200	1200	61,000	27	26 7/8	61 3/4	8 1/4 x 45	245
AVR-03420	34.5	200	2000	100,000	27	26 7/8	61 3/4	8 1/4 x 45	253
AVR-04612	46	250	1200	61,000	30	30 7/8	68 3/4	8 1/4 x 48	297
AVR-04620	46	250	2000	100,000	30	30 7/8	68 3/4	8 1/4 x 48	305
AVR-06912	69	350	1200	61,000	42	38 7/8	88 3/4	8 1/4 x 60	409
AVR-06920	69	350	2000	100,000	42	38 7/8	88 3/4	8 1/4 x 60	423
AVR-11512	115	550	1200	61,000	60	58 3/4	126 5/8	8 1/4 x 72	899
AVR-11520	115	550	2000	100,000	60	58 3/4	126 5/8	8 1/4 x 72	903
AVR-13812	138	650	1200	61,000	72	67 3/4	147 5/8	8 1/4 x 84	994
AVR-13820	138	650	2000	100,000	72	67 3/4	147 5/8	8 1/4 x 84	1002
AVR-16112	161	750	1200	61,000	84	77 3/4	169 5/8	8 1/4 x 96	1141
AVR-16120	161	750	2000	100,000	84	77 3/4	169 5/8	8 1/4 x 96	1154
AVR-23012-9	230	900	1200	61,000	96	95 3/4	200 1/2	8 1/4 x 108	1579
AVR-23020-9	230	900	2000	100,000	96	95 3/4	200 1/2	8 1/4 x 108	1597
AVR-23012-10	230	1050	1200	61,000	114	107 3/4	230 1/2	8 1/4 x 120	1800
AVR-23020-10	230	1050	2000	100,000	114	107 3/4	230 1/2	8 1/4 x 120	1822

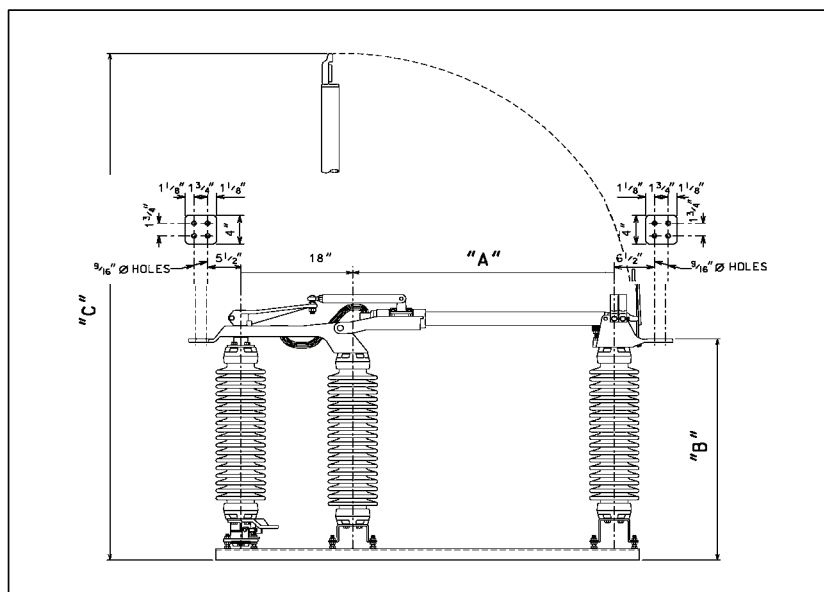

DIMENSIONS SHOWN IN INCHES - WEIGHT SHOWN IN POUNDS (INSULATORS INCLUDED)

7.5 - 69 kV 3" BOLT CIRCLE STATION POST INSULATORS

115 - 230 kV 5" BOLT CIRCLE STATION POST INSULATORS

DIMENSIONS NOT FOR CONSTRUCTION PURPOSES

CONTACT FACTORY FOR CERTIFIED PRINTS

JANUARY 2009

HUBBELL / USCO - LEEDS, ALABAMA USA



USCO[™]
Power Switches

VERTICAL BREAK SWITCH

TYPE AVR

7.5 - 230 kV

CATALOG NO.	RATINGS									
	VOLTAGE (kV)			CURRENT (A)				INS.	BOLT CIRCLE	WEIGHT SINGLE POLE (lbs.)
ALUMINUM SWITCH	NOM. (rms)	MAX. (rms)	BIL (peak)	CONT.	PEAK	MOM.	3 SEC.			
AVR-00712	7.5	8.3	95	1200	99,000	61,000	38,000	TR-202	3"	165
AVR-00720	7.5	8.3	95	2000	164,000	100,000	62,500	TR-202	3"	172
AVR-00730	7.5	8.3	95	3000	195,000	120,000	75,000	TR-222	5"	271
AVR-01512	15	15.5	110	1200	99,000	61,000	38,000	TR-205	3"	175
AVR-01520	15	15.5	110	2000	164,000	100,000	62,500	TR-205	3"	182
AVR-01530	15	15.5	110	3000	195,000	120,000	75,000	TR-225	5"	286
AVR-02312	23	27.0	150	1200	99,000	61,000	38,000	TR-208	3"	210
AVR-02320	23	27.0	150	2000	164,000	100,000	62,500	TR-208	3"	217
AVR-02330	23	27.0	150	3000	195,000	120,000	75,000	TR-227	5"	356
AVR-03412	34.5	38.0	200	1200	99,000	61,000	38,000	TR-210	3"	245
AVR-03420	34.5	38.0	200	2000	164,000	100,000	62,500	TR-210	3"	253
AVR-03430	34.5	38.0	200	3000	195,000	120,000	75,000	TR-231	5"	441
AVR-04612	46	48.3	250	1200	99,000	61,000	38,000	TR-214	3"	297
AVR-04620	46	48.3	250	2000	164,000	100,000	62,500	TR-214	3"	305
AVR-04630	46	48.3	250	3000	195,000	120,000	75,000	TR-267	5"	502
AVR-06912	69	72.5	350	1200	99,000	61,000	38,000	TR-216	3"	409
AVR-06920	69	72.5	350	2000	164,000	100,000	62,500	TR-216	3"	423
AVR-06930	69	72.5	350	3000	195,000	120,000	75,000	TR-278	5"	810
AVR-11512	115	123	550	1200	99,000	61,000	38,000	TR-286	5"	899
AVR-11520	115	123	550	2000	164,000	100,000	62,500	TR-286	5"	903
AVR-11530	115	123	550	3000	195,000	120,000	75,000	TR-286	5"	943
AVR-13812	138	145	650	1200	99,000	61,000	38,000	TR-288	5"	994
AVR-13820	138	145	650	2000	164,000	100,000	62,500	TR-288	5"	1002
AVR-13830	138	145	650	3000	195,000	120,000	75,000	TR-288	5"	1048
AVR-16112	161	170	750	1200	99,000	61,000	38,000	TR-291	5"	1141
AVR-16120	161	170	750	2000	164,000	100,000	62,500	TR-291	5"	1154
AVR-16130	161	170	750	3000	195,000	120,000	75,000	TR-291	5"	1188
AVR-23012-9	230	245	900	1200	99,000	61,000	38,000	TR-304	5"	1579
AVR-23020-9	230	245	900	2000	164,000	100,000	62,500	TR-304	5"	1597
AVR-23030-9	230	245	900	3000	195,000	120,000	75,000	TR-304	5"	1609
AVR-23012-10	230	245	1050	1200	99,000	61,000	38,000	TR-312	5"	1800
AVR-23020-10	230	245	1050	2000	164,000	100,000	62,500	TR-312	5"	1822
AVR-23030-10	230	245	1050	3000	195,000	120,000	75,000	TR-312	5"	1844



USCO™
Power Switches

SIDE BREAK SWITCH

TYPE ASB



S
I
D
E

B
R
E
A
K

S
W
I
T
C
H

VOLTAGE RATING *15kV to 69kV*
CURRENT RATING *1200 to 2000A*

ASB Aluminum Side Break

The **ASB** is a two insulator, side break outdoor air disconnect switch constructed primarily of aluminum. Operation is accomplished by the rotation of the hinge insulator. Proven by years of field experience, this switch takes full advantage of unique construction methods to provide both simple operation and long-term dependability.

- Economical Yet Dependable
- Welded Lamination Design
- Reverse Loop Contacts For Short Circuit Withstand
- Durable, Reliable Operation

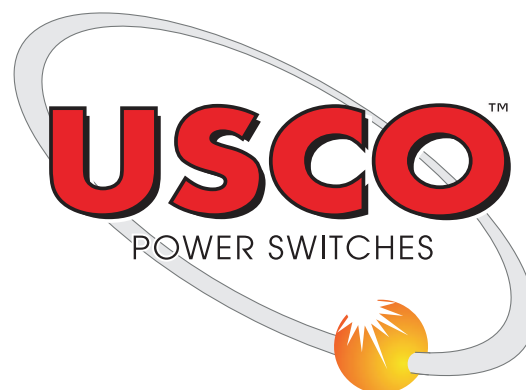

SINCE 1946, THE ENGINEERS CHOICE FOR HIGH VOLTAGE PRODUCTS

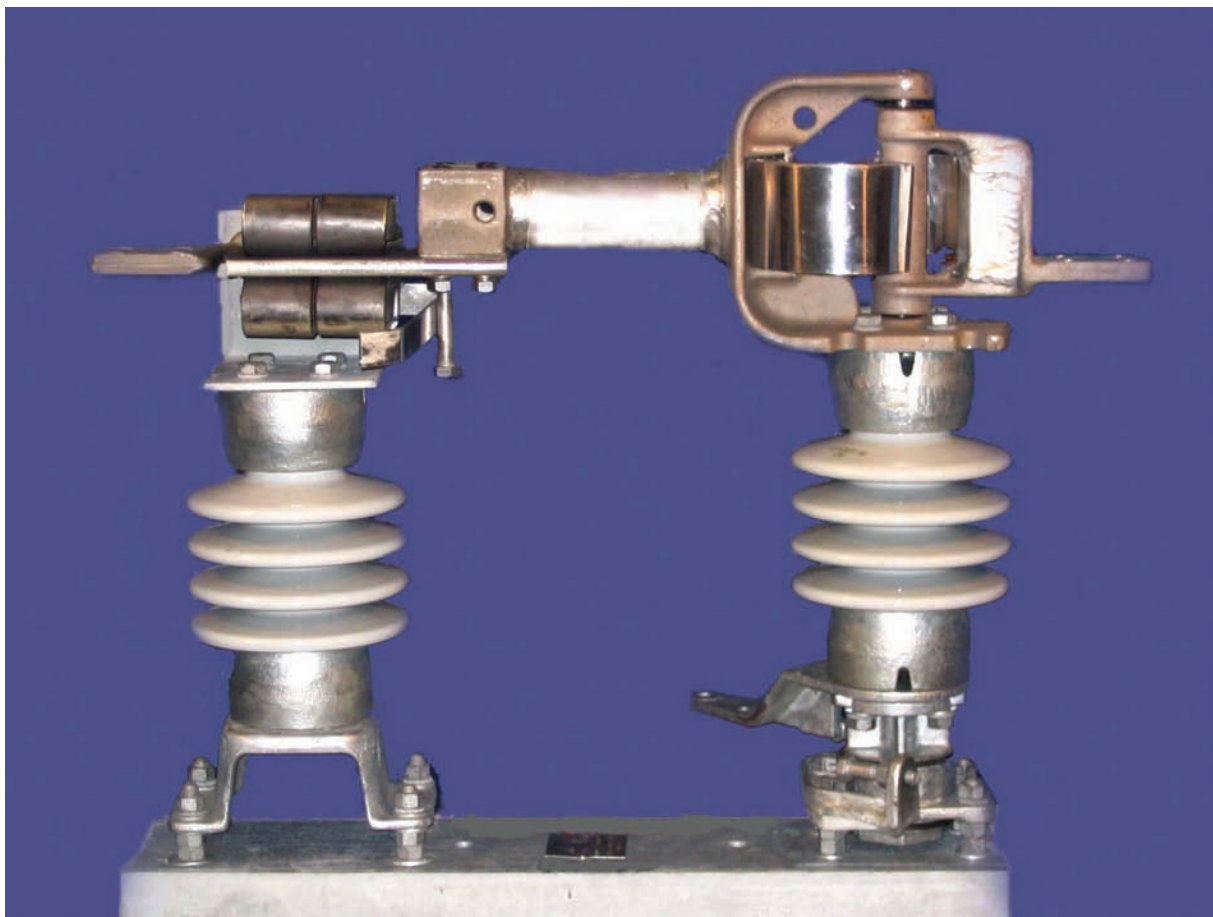

DESCRIPTION

The **ASB** is an outdoor, group-operated side opening two insulator, air disconnect switch with only the hinge insulator rotating during operation. The **ASB** is constructed primarily of aluminum and is available in ratings from 7.5kV through 69kV nominal (8.25kV through 72.5kV maximum) and 1200 through 2000 continuous amperes. The side break is the most economical of all group-operated switches.

APPLICATION

The **ASB** is commonly used in three-phase line or substation applications such as transformer or line disconnecting, breaker isolating, bypassing or bus sectionalizing. Operation of the **ASB** may be accomplished by either manual control or by motor operator.

TESTING

The **ASB** has been extensively tested to meet or exceed current ANSI standards. A comprehensive test brochure is available outlining electrical and mechanical design test conducted on the **ASB**.



USCO™
Power Switches

DESIGN CHARACTERISTICS

Contacts

The **ASB** is supplied with reverse loop, silver-to-silver jaw contacts producing the highest conductivity initially and over time.

The contact fingers, fabricated from hard drawn copper, are silver plated, then electro-tin plated.

The male contact, also of hard drawn copper is silver metallized and then electro-tin plated. These methods and materials used in the application of the silver provide surfaces of differing hardness with anti-galling properties, resulting in minimal wear over years of operation.

All contacts on the **ASB** are field replaceable.

The **ASB** uses USCO's time tested welded lamination hinge assembly producing a straight-line current path eliminating any current transfer at the hinge. This is accomplished with a welded aluminum laminated conductor that is used to create a bypass at the hinge. This eliminates the need for bolted or sliding pressure connections, or high pressure contacts, and enables ease of operation. The welded connections create a single metallic path from the hinge terminal pads to the main



contacts on the blades of the switch. The laminated conductor is constructed of commercially pure aluminum strip, which does not work harden during operation.

Blade

The blade is constructed of heat-treated aluminum tubing with heat-treated aluminum castings welded to hinge and jaw ends.



S
I
D
E
B
R
E
A
K
S
W
I
T
C
H

ACCESSORIES

- Grounding switches: Through 100kA momentary
- Auxiliary switches: Up to 12 contact decks are standard
- Standard arcing horns are installed on all switches
- Outriggers: Custom designed for your application
- Connectors: Available on all switch types



USCO™
Power Switches

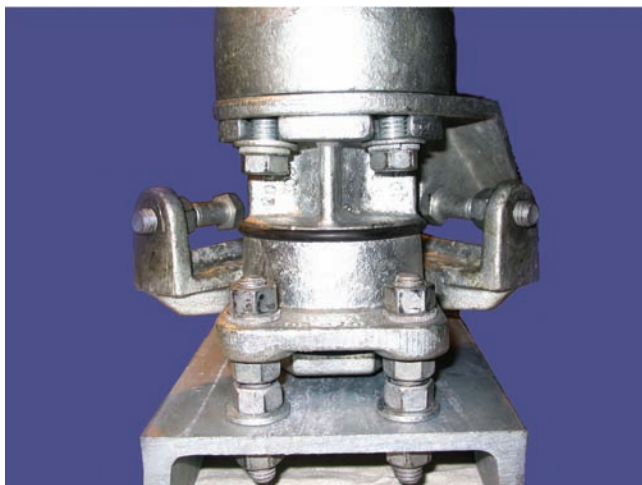

Main Switch Bearings

The **ASB** incorporates rugged switch bearings consisting of stainless steel balls, utilizing stainless steel bearing races with galvanized ductile iron housings and rotors. The bearings are sealed at the factory for maintenance free service. Factory adjusted stops are provided with the bearing for ease of synchronization during installation.

Switch Bases

Hot dipped structural steel channel is used for the construction of the switch base. Leveling studs are provided on the bearings for insulator alignment. Bases and base mounting dimensions can be customized to your specifications and structure.

Insulators

The **ASB** is designed to accommodate commercially available insulators with three or five inch bolt circles.

Operating Mechanisms

The **ASB** may be operated with a swing handle, gearbox or motor operator. Control arrangements are factory designed and customized to your structure, with all linkage components factory cut to the required dimensions.

Hinge Current Transfer

The **ASB** has no hinge contacts; therefore it allows current transfer with maximum reliability.

Transfer of current at the hinge end of the blade is accomplished with a welded aluminum laminated conductor, precisely formed and assembled to give thousands of trouble-free operations. This eliminates bolted or sliding pressure connections, threaded joints or high-pressure contacts, enabling ease of operation. Welded connections create a single conductive metallic path from the hinge terminal pad to the jaw end of the blade.

The laminated conductor is constructed of commercially pure aluminum strip, which does not work harden during operation. Extensive mechanical, electrical, and environmental testing along with years of field experience, prove this approach to current transfer superior to any conventional enclosed or open-hinge contact design.

SIDE BREAK SWITCH

TYPE ASB

7.5 - 69 kV

1200 Amperes



USCO[™]
Power Switches

CATALOG NO.	RATINGS				DIMENSIONS			STD MTG	WEIGHT 1 Pole
	VOLTAGE (kV)	BIL kV	CURRENT (A)	MOM.	A	B	C		
ASB-00712	7.5	95	1200	61,000	18	17 5/8	19 1/2	8 1/4 X 18	145
ASB-01512	15	110	1200	61,000	18	20 1/8	19 1/2	8 1/4 X 18	155
ASB-02312	23	150	1200	61,000	21	24 1/8	22 1/2	8 1/4 X 21	175
ASB-03412	34.5	200	1200	61,000	27	28 1/8	28 1/2	8 1/4 X 27	200
ASB-04612	46	250	1200	61,000	30	32 1/8	31 1/2	8 1/4 X 30	240
ASB-06912	69	350	1200	61,000	42	40 1/8	43 1/2	8 1/4 X 42	305

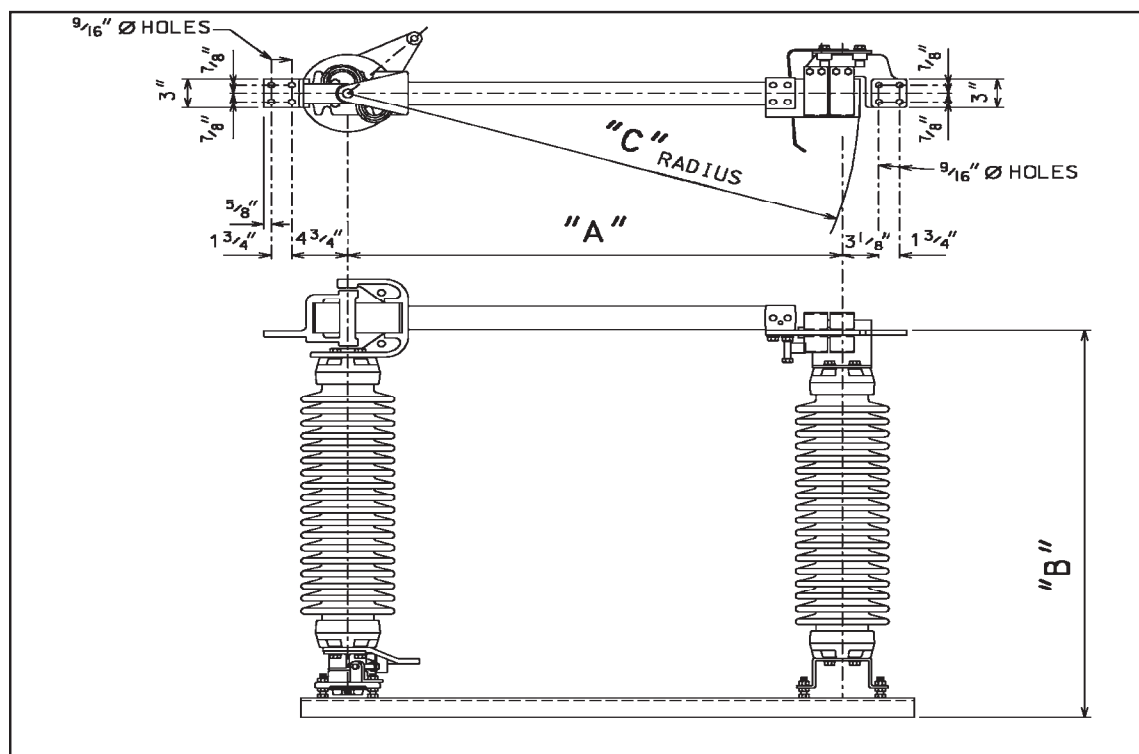

DIMENSIONS SHOWN IN INCHES - WEIGHT SHOWN IN POUNDS (INSULATORS INCLUDED)

7.5 - 69 kV 3" BOLT CIRCLE STATION POST INSULATORS

DIMENSIONS NOT FOR CONSTRUCTION PURPOSES

CONTACT FACTORY FOR CERTIFIED PRINTS

S
I
D
E
B
R
E
A
K
S
W
I
T
C
H



USCO™
Power Switches

SIDE BREAK SWITCH

TYPE ASB

7.5 - 69 kV

2000 Amperes

CATALOG NO.	RATINGS				DIMENSIONS			STD MTG	WEIGHT 1 Pole
	VOLTAGE (kV)		CURRENT (A)		A	B	C		
ASB-00720	7.5	95	2000	100,000	18	17 5/8	21 3/4	8 1/4 X 18	150
ASB-01520	15	110	2000	100,000	18	20 1/8	21 3/4	8 1/4 X 18	160
ASB-02320	23	150	2000	100,000	21	24 1/8	24 3/4	8 1/4 X 21	180
ASB-03420	34.5	200	2000	100,000	27	28 1/8	30 3/4	8 1/4 X 27	205
ASB-04620	46	250	2000	100,000	30	32 1/8	33 3/4	8 1/4 X 30	245
ASB-06920	69	350	2000	100,000	42	40 1/8	45 3/4	8 1/4 X 42	315

SIDE BREAK SWITCH

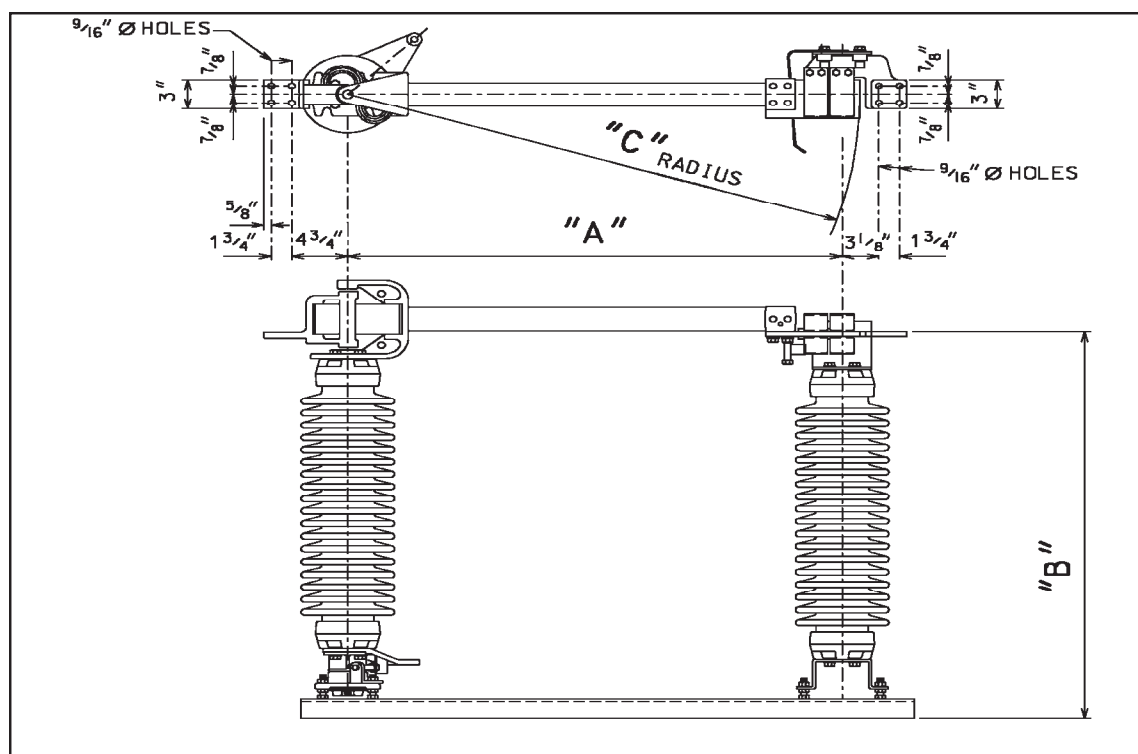

DIMENSIONS SHOWN IN INCHES - WEIGHT SHOWN IN POUNDS (INSULATORS INCLUDED)

7.5 - 69 kV 3" BOLT CIRCLE STATION POST INSULATORS

DIMENSIONS NOT FOR CONSTRUCTION PURPOSES

CONTACT FACTORY FOR CERTIFIED PRINTS

SIDE BREAK SWITCH
TYPE ASB
 7.5 - 69 kV



USCO™
 Power Switches

CATALOG NO	RATINGS									
	VOLTAGE (kV)			CURRENT (A)				INS.	BOLT CIRCLE	WEIGHT SINGLE POLE (lbs.)
ALUMINUM SWITCH	NOM.	MAX DES.	BIL.	CONT.	PEAK	MOM.	3 SEC.			
ASB-00712	7.5	8.3	95	1200	99,000	61,000	38,000	TR-202	3"	145
ASB-00720	7.5	8.3	95	2000	164,000	100,000	62,500	TR-202	3"	150
ASB-01512	15	15.5	110	1200	99,000	61,000	38,000	TR-205	3"	155
ASB-01520	15	15.5	110	2000	164,000	100,000	62,500	TR-205	3"	160
ASB-02312	23	27	150	1200	99,000	61,000	38,000	TR-208	3"	175
ASB-02320	23	27	150	2000	164,000	100,000	62,500	TR-208	3"	180
ASB-03412	34.5	38	200	1200	99,000	61,000	38,000	TR-210	3"	200
ASB-03420	34.5	38	200	2000	164,000	100,000	62,500	TR-210	3"	205
ASB-04612	46	48.3	250	1200	99,000	61,000	38,000	TR-214	3"	240
ASB-04620	46	48.3	250	2000	164,000	100,000	62,500	TR-214	3"	245
ASB-06912	69	72.5	350	1200	99,000	61,000	38,000	TR-216	3"	305
ASB-06920	69	72.5	350	2000	164,000	100,000	62,500	TR-216	3"	315

S
I
D
E
B
R
E
A
K
S
W
I
T
C
H



USCO™
Power Switches

HOOKSTICK SWITCH

TYPE HH



VOLTAGE RATING

7.5kV to 69kV

CURRENT RATING

600 to 4000A

HH Hookstick Switch

The **HH** is a hookstick operated switch for substation applications, tandem transfer duty as well as distribution and substation by-pass units. These units are premium quality, heavy duty and meet all industry electrical and mechanical standards.

- 4 to 1 Mechanical Pry-Out Ease In Switch Operation
- Parallel Bus Bars, Trussed for Maximum Rigidity
- Versatile Designs Offer Many Application Solutions

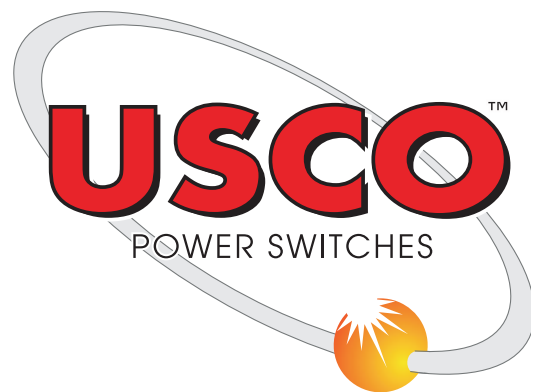

SINCE 1946, THE ENGINEERS CHOICE FOR HIGH VOLTAGE PRODUCTS



USCO™
Power Switches

HOOKSTICK SWITCH

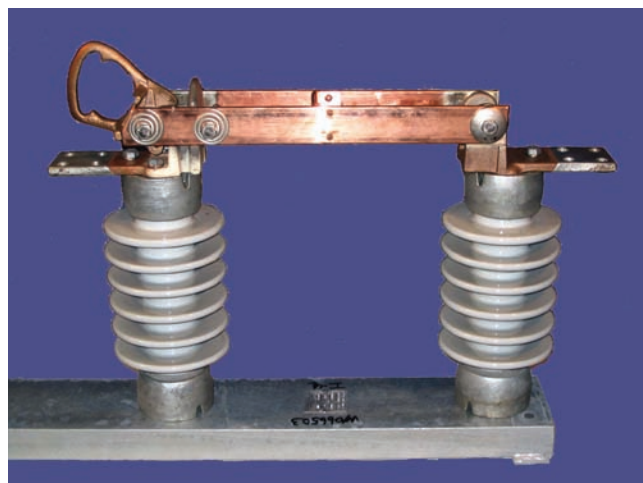

The **HH6** is a premium quality outdoor single pole, hookstick disconnect switch designed primarily for heavy duty substation applications.

DESCRIPTION

The **HH** is an outdoor, hookstick operated, air disconnect switch. The HH is constructed primarily of copper and bronze and is available in ratings from 7.5kV through 69kV nominal (8.25kV through 72.5kV maximum) and 600 through 4000 continuous amperes. The hookstick switch is premium quality and a heavy-duty design. An oversize operating ring and 4 to 1 mechanical pry-outs, aids the operator in operating the switch. A positive latch locks the switch in the closed position assuring that it will not open under the most adverse vibration or short circuit conditions.

APPLICATION

The **HH** is commonly used in substation applications such as transformer disconnecting, breaker isolating and bypassing as well as tandem transfer duty. Versatile designs offer many application solutions.

TESTING

The **HH** has been extensively tested to meet or exceed current ANSI standards. A comprehensive test brochure is available outlining electrical and mechanical design test conducted on the **HH**.

LOW PROFILE HOOKSTICK SWITCH

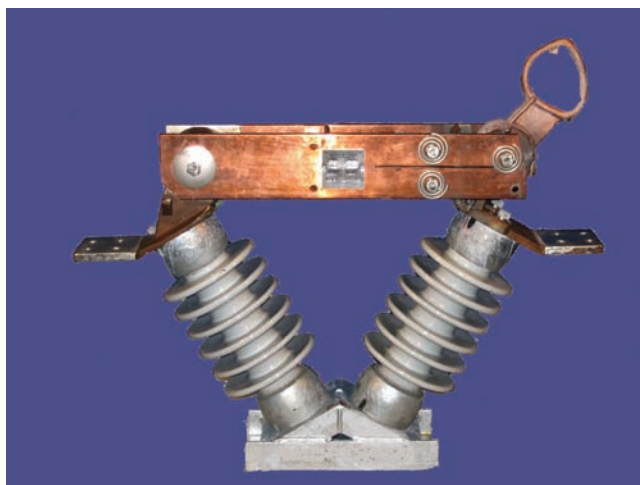

The **HH6V**, with insulators mounted in a V-configuration, offers many advantages where mounting space is limited, and for installation on low profile structures.

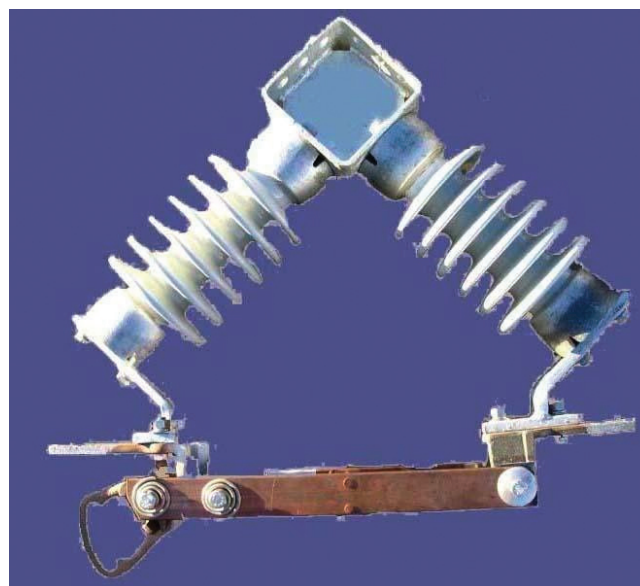

The **HH45-6**, is another popular low profile design.



USCO™
Power Switches

Contacts

The **HH** supplied with high-pressure silver to copper contacts at 600 amp and silver to silver at 1200 amp and above producing the highest conductivity initially and over time. The bronze contact casting has a brazed silver overlay that mates with silver electroplated blades. The methods and materials used in the application of silver provide surfaces of differing hardness with anti-galling properties, resulting in minimal wear over years of operation.

Blade

The blade is constructed of parallel copper bars that are trussed giving the blade maximum rigidity. Standard blade stops are set at 90 degrees.

Switch Bases

Hot dipped galvanized, single channel structural steel is used for the construction of the switch base.

Insulators

The **HH** is designed to accommodate commercially available insulators with three or five inch bolt circles. Insulators are assembled inverted so switch can be installed under hung or vertical without disassembly.

Terminals

NEMA drilled terminal pads – $\frac{9}{16}$ " holes on a $1\frac{3}{4}$ " centers, 2-hole pads on 600 ampere switches. 4-hole pads 1200 amperes through 3000 amperes. Tinned terminal pads are standard.

TANDEM HOOKSTICK SWITCH

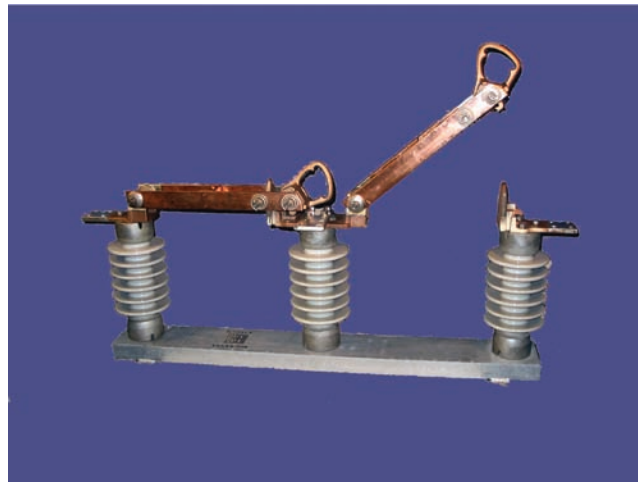

The **HH6T** is a tandem transfer switch designed to provide a compact method of transferring load to alternate circuits.

REGULATOR BYPASS SWITCH



The **HHR6** is a three blade, heavy duty, substation switch used for bypassing substation regulators.

HOOKSTICK SWITCH

TYPE HH6

7.5 - 69 kV

600 - 4000 Amperes

The HH6 is a premium quality outdoor single pole, hookstick disconnect switch designed primarily for heavy duty substation applications.



USCO[™]
Power Switches

CATALOG NO.	RATINGS				DIMENSIONS			STD MTG	WEIGHT 1 Pole
	VOLTAGE (kV)		CURRENT (A)		A	B	C		
	NOM.	BIL	CONT.	MOM.					
HH6-00706	7.5	95	600	40,000	12	7 1/2	9 13/16	2 x 18	46
HH6-00712	7.5	95	1200	61,000	12	7 1/2	9 15/16	2 x 18	61
HH6-00720	7.5	95	2000	100,000	12	7 1/2	9 7/8	2 x 18	75
HH6-00730	7.5	95	3000	120,000	15	10	12 5/8	2 x 21	89
HH6-01506	15	110	600	40,000	15	10	12 5/16	2 x 21	59
HH6-01512	15	110	1200	61,000	15	10	12 7/16	2 x 21	74
HH6-01520	15	110	2000	100,000	15	10	12 3/8	2 x 21	85
HH6-01530	15	110	3000	120,000	18	12	14 5/8	2 x 24	101
HH6-02306	23	150	600	40,000	18	14	16 5/16	2 x 24	77
HH6-02312	23	150	1200	61,000	18	14	16 7/16	2 x 24	94
HH6-02320	23	150	2000	100,000	18	14	16 3/8	2 x 24	104
HH6-02330	23	150	3000	120,000	21	15	18 5/8	2 x 27	115
HH6-03406	34.5	200	600	40,000	24	18	20 5/16	2 x 30	114
HH6-03412	34.5	200	1200	61,000	24	18	20 7/16	2 x 30	129
HH6-03420	34.5	200	2000	100,000	24	18	20 3/8	2 x 30	139
HH6-03430	34.5	200	3000	120,000	27	20	22 5/8	2 x 33	150
HH6-04606	46	250	600	40,000	30	22	24 5/16	2 x 36	147
HH6-04612	46	250	1200	61,000	30	22	24 7/16	2 x 36	179
HH6-04620	46	250	2000	100,000	30	22	24 3/8	2 x 45	199
HH6-04630	46	250	3000	120,000	33	24	26 5/8	2 x 39	224
HH6-06912	69	350	1200	61,000	42	30	31 7/8	2 x 48	275
HH6-06920	69	350	2000	100,000	42	30	32 3/8	2 x 48	305

For 4000 Ampere Switches Consult Factory

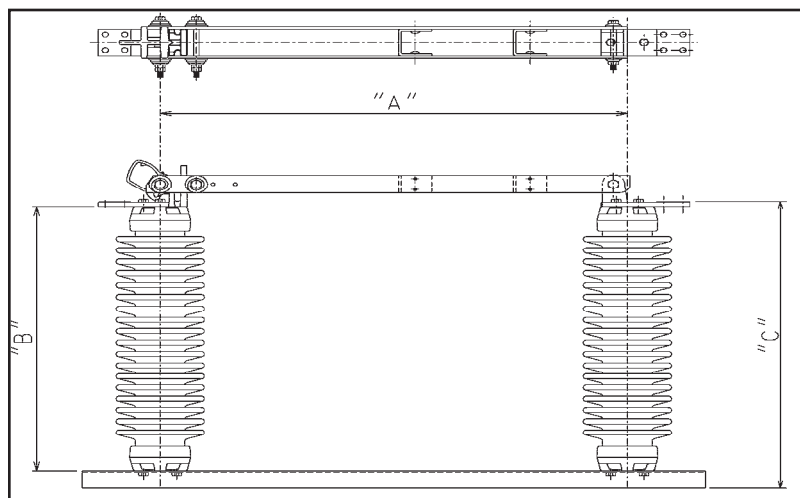

DIMENSIONS SHOWN IN INCHES - WEIGHT SHOWN IN POUNDS (INSULATORS INCLUDED)
7.5 - 69 kV 3" BOLT CIRCLE STATION POST INSULATORS
DIMENSIONS NOT FOR CONSTRUCTION PURPOSES
CONTACT FACTORY FOR CERTIFIED PRINTS



USCO™
Power Switches

LOW PROFILE HOOKSTICK SWITCH

TYPE HH6V

7.5 - 69 kV

600 - 2000 Amperes

The HH6V, with insulators mounted in a V-configuration, offers many advantages where mounting space is limited, and for installation on low profile structures.

CATALOG NO.	RATINGS				DIMENSIONS					STD MTG	WEIGHT 1 Pole
	VOLTAGE (kV)		CURRENT (A)		A	B	C	D	E		
	NOM.	BIL	CONT.	MOM.							
HH6V-00706	7.5	95	600	40	20	7 1/2	9 1/8	7	5 7/8	7 x 12	40
HH6V-00712	7.5	95	1200	61	20	7 1/2	9 1/8	7	5 7/8	7 x 12	56
HH6V-00720	7.5	95	2000	100	22 1/4	7 1/2	8 1/4	7	5 7/8	7 x 12	68
HH6V-01506	15	110	600	40	23	10	11 1/8	10	5 7/8	7 x 12	59
HH6V-01512	15	110	1200	61	23	10	11 1/8	10	5 7/8	7 x 12	74
HH6V-01520	15	110	2000	100	25 1/4	10	10 3/8	10	5 7/8	7 x 12	85
HH6V-02306	23	150	600	40	26	14	14 3/8	10	5 7/8	7 x 12	77
HH6V-02312	23	150	1200	61	26	14	14 3/8	12	5	7 x 12	94
HH6V-02320	23	150	2000	100	27 1/4	14	13 7/8	12	5	7 x 12	104
HH6V-03406	34.5	200	600	40	32	18	17 3/4	18	7 1/4	7 x 12	114
HH6V-03412	34.5	200	1200	61	32	18	17 3/4	18	7 1/4	7 x 12	129
HH6V-03420	34.5	200	2000	100	33 1/4	18	17 5/8	18	7	7 x 12	143
HH6V-04606	46	250	600	40	38	22	21	22	8 1/4	7 x 12	147
HH6V-04612	46	250	1200	61	38	22	21	22	8 1/4	7 x 12	179
HH6V-04620	46	250	2000	100	39 1/4	22	21	24	7	7 x 12	199
HH6V-06912	69	350	1200	61	50	30	28 1/4	32	12 1/2	7 x 12	275
HH6V-06920	69	350	2000	100	50	30	28 1/4	32	12 1/2	7 x 12	300

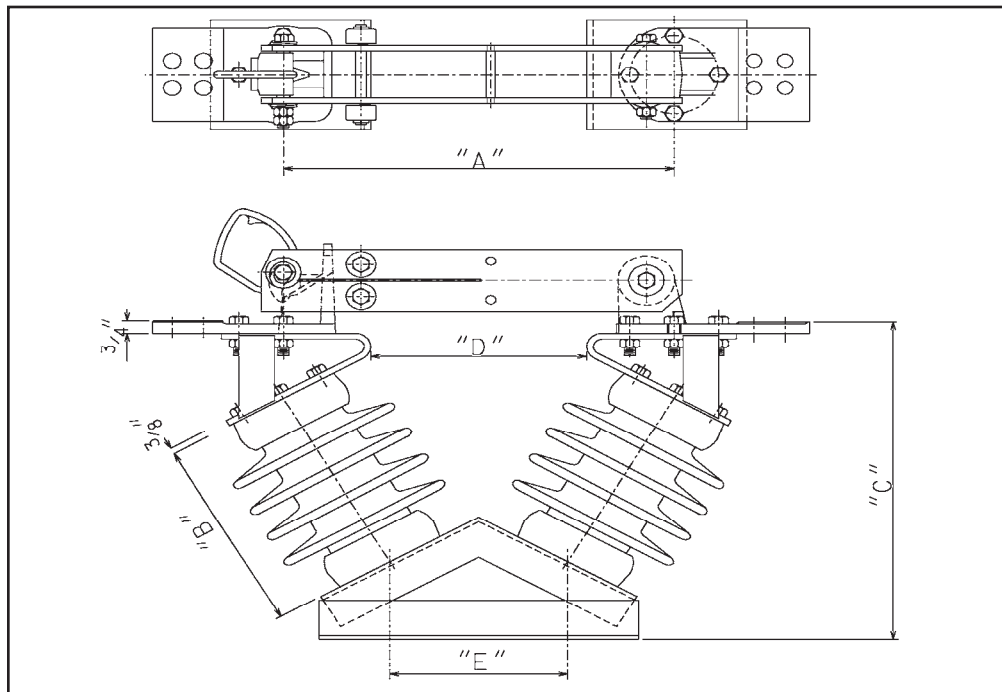

DIMENSIONS SHOWN IN INCHES - WEIGHT SHOWN IN POUNDS (INSULATORS INCLUDED)

7.5 - 69 kV 3" BOLT CIRCLE STATION POST INSULATORS

DIMENSIONS NOT FOR CONSTRUCTION PURPOSES

CONTACT FACTORY FOR CERTIFIED PRINTS

TANDEM HOOKSTICK SWITCH

TYPE HH6T

7.5 - 69 kV

600 - 1200 Amperes



USCO™
Power Switches

The HH6T is a tandem transfer switch designed to provide a compact method of transferring load to alternate circuits.

CATALOG NO.	RATINGS				DIMENSIONS				WEIGHT 1 Pole
	NOM. (kV)	BIL	CONT. (A)	MOM. (A)	A	B	C	D	
HH6T-00706	7.5	95	600	40,000	15	7 7/8	10 1/8	18	87
HH6T-00712	7.5	95	1200	61,000	15	7 1/2	9 3/4	18	132
HH6T-01506	15	110	600	40,000	18	10 3/8	12 5/8	21	108
HH6T-01512	15	110	1200	61,000	18	10	12 1/4	21	146
HH6T-02306	23	150	600	40,000	21	14 3/8	16 5/8	24	135
HH6T-02312	23	150	1200	61,000	21	14	16 1/4	24	182
HH6T-03406	34.5	200	600	40,000	27	18 3/8	20 5/8	30	191
HH6T-03412	34.5	200	1200	61,000	27	18	20 1/4	30	242
HH6T-04606	46	250	600	40,000	33	22	22 3/8	36	225
HH6T-04612	46	250	1200	61,000	33	22	24 1/4	36	268
HH6T-06912	69	350	1200	61,000	45	30	32 1/4	48	340

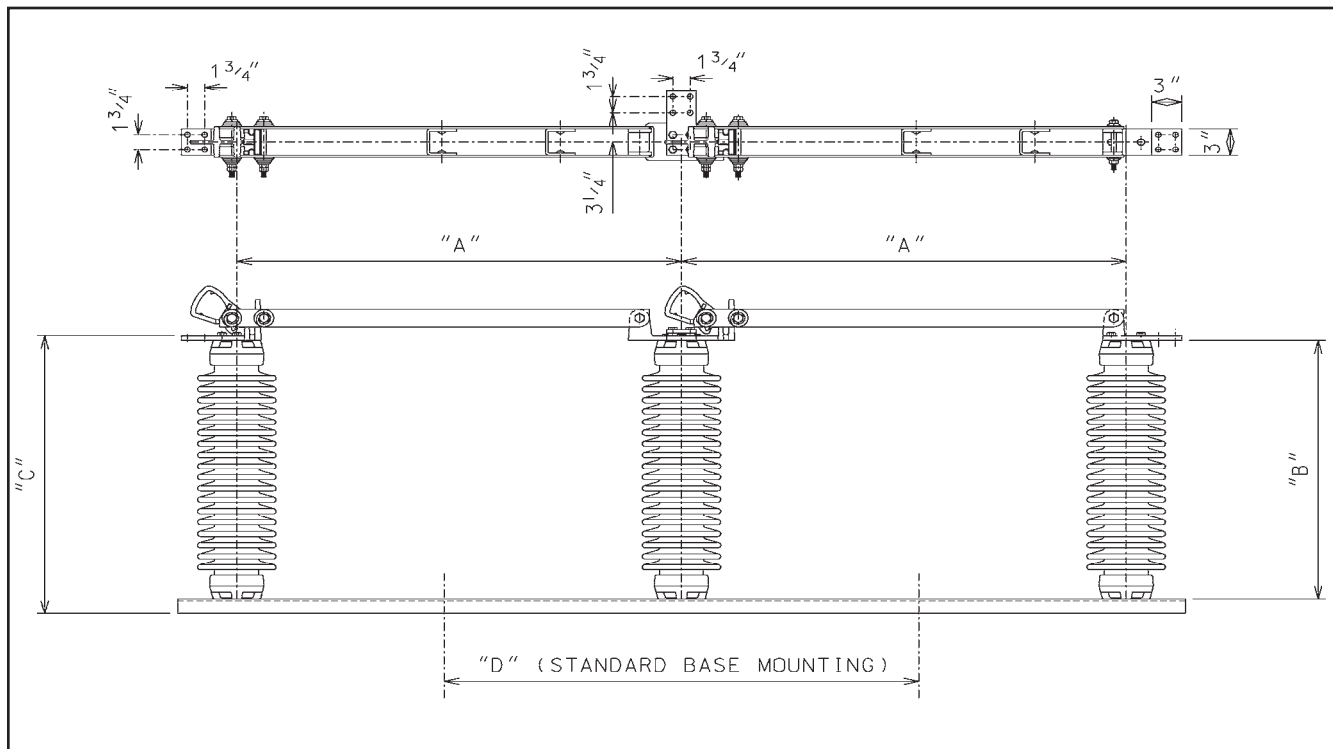

DIMENSIONS SHOWN IN INCHES - WEIGHT SHOWN IN POUNDS (INSULATORS INCLUDED)

7.5 - 69 kV 3" BOLT CIRCLE STATION POST INSULATORS

DIMENSIONS NOT FOR CONSTRUCTION PURPOSES

CONTACT FACTORY FOR CERTIFIED PRINTS

HOOKSTICK SWITCH



USCO™
Power Switches

**REGULATOR BYPASS
HOOKSTICK SWITCH
TYPE HHR6**
7.5 - 34.5 kV
600 - 2000 Amperes

The HHR6 is a three blade, heavy duty, substation switch providing a compact, easily installed unit for bypassing substation regulators.

CATALOG NO.	RATINGS				DIMENSIONS				STD MTG	WEIGHT 1 Pole
	NOM.	BIL	CONT.	MOM.	A	B	C	D		
HHR-00706	7.5	95	600	40,000	18	7 1/2	11 13/16	29 1/4	2 x 24	137
HHR-00712	7.5	95	1200	61,000	18	7 1/2	12 3/16	29 1/2	2 x 24	169
HHR-00720	7.5	95	2000	100,000	18	7 1/2	12 3/16	33 5/16	2 x 24	204
HHR-01506	15	110	600	40,000	21	10	14 5/16	31 3/4	2 x 27	165
HHR-01512	15	110	1200	61,000	21	10	14 11/16	32	2 x 27	198
HHR-01520	15	110	2000	100,000	21	10	14 11/16	35 13/16	2 x 27	235
HHR-02306	23	150	600	40,000	24	14	18 5/16	36 3/8	2 x 30	200
HHR-02312	23	150	1200	61,000	24	14	18 11/16	36	2 x 30	232
HHR-02320	23	150	2000	100,000	24	14	18 11/16	39 13/16	2 x 30	270
HHR-03406	34.5	200	600	40,000	30	18	22 5/16	40 3/8	2 x 36	245
HHR-03412	34.5	200	1200	61,000	30	18	22 11/16	40	2 x 36	276
HHR-03420	34.5	200	2000	100,000	30	18	22 11/16	43 13/16	2 x 36	300

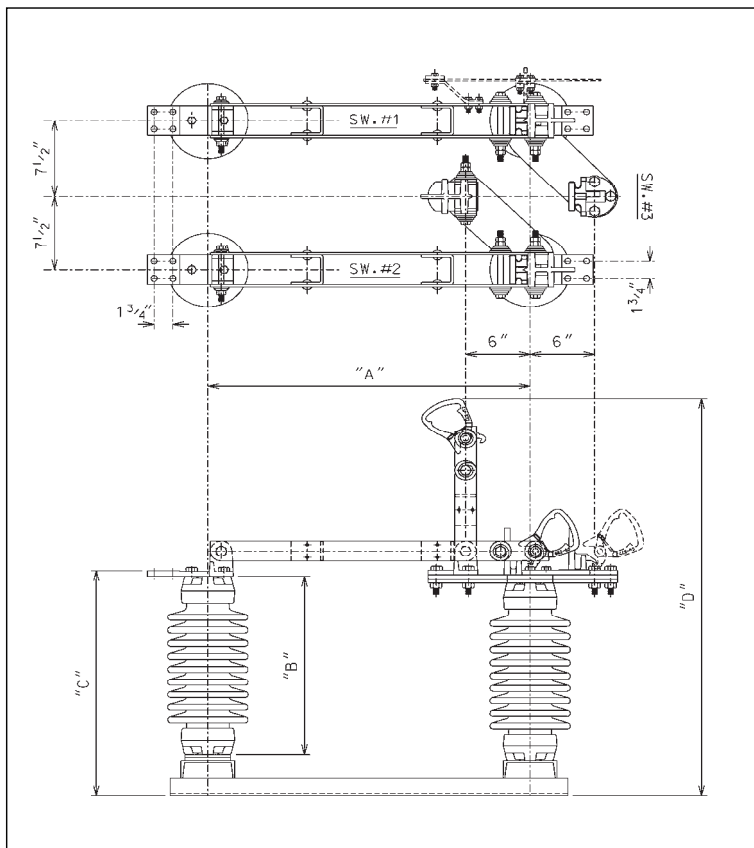

DIMENSIONS SHOWN IN INCHES - WEIGHT SHOWN IN POUNDS (INSULATORS INCLUDED)

7.5 - 34 kV 3" BOLT CIRCLE STATION POST INSULATORS

DIMENSIONS NOT FOR CONSTRUCTION PURPOSES

CONTACT FACTORY FOR CERTIFIED PRINTS

SWITCH ACCESSORIES



USCO™
Power Switches

Auxiliary Switches

The addition of auxiliary switches to switch operating mechanisms offers a means of remote switch position indication, electrical interlocking of main and ground switch, etc. USCO auxiliary switches are outdoor type, complete with weatherproof housing, operating crank, and control linkage.

□ 12 Stage (6-a and 6-b)



Grounding Switches

Grounding switches are supplied as an addition to the main switch, or as a separate unit. They can be installed on either the jaw or hinge end of the main switch. Grounding switches are normally interlocked with the main switch to prevent the closing of both switches at the same time.

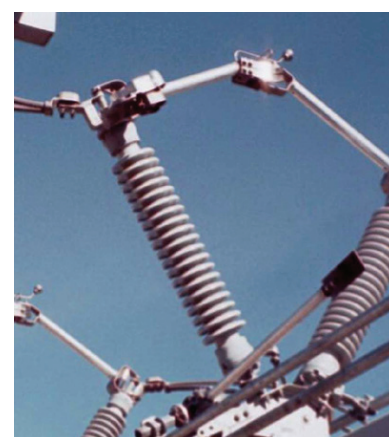

Interlocks

Mechanical interlocks are used primarily for interlocking ground and main switches to prevent both switches being opened at the same time. USCO has available two types of interlocks (1) mechanical, and (2) Kirk Key.



Outriggers

Outriggers are furnished when it is necessary to extend the conductors out from the switch base or other grounded parts.





USCO™
Power Switches

Grounding Plates

Grounding plates are installed at the base of the structure to ground personnel while operating switches. The USCO grounding plate is available in a 48" x 36" 3/16" thick galvanized steel checker plate. Consult factory for custom sizes.

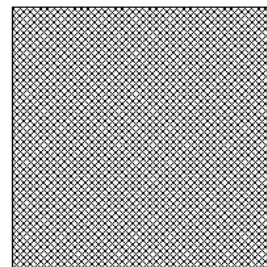

Insulated Controls

A porcelain insulator can be used for insulating the vertical operating pipe. The insulator is a standard 15 kV station post insulator with fittings for installing the vertical pipe.

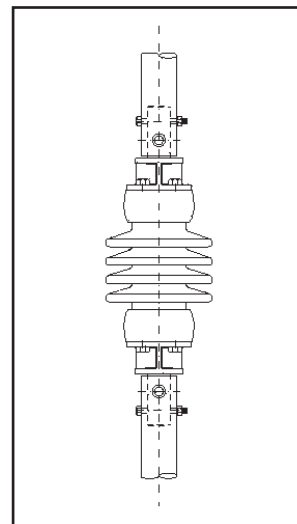

Pole Bands

USCO's multi-purpose galvanized ductile iron, pole bands (MK-678-7) are utilized for a wide variety of pole-mounted equipment. Adjustable to fit poles 6" to 24" in diameter.



Spark Gaps

Spark gaps provide a protective gap between live parts and ground to limit any maximum over-voltage that may occur.

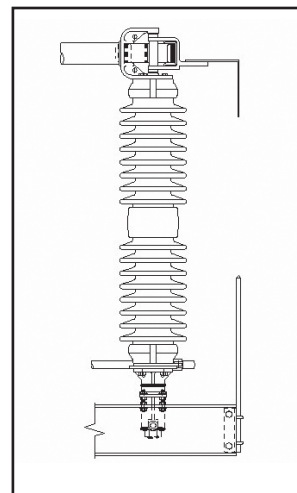

INTERRUPTING DEVICES



USCO™
Power Switches

Arcing Horns

Standard arcing horns are designed to prevent arcing at the main switch contacts. Although they are given no interrupting rating, it is common practice to use these devices to interrupt small values of current such as the charging current of a short length of line or transformer magnetizing current. It should be recognized that the confined electric arc at the switch contacts could cause damage to the switch, and involve adjacent phases, or supporting structure, in the initiation of a major fault.

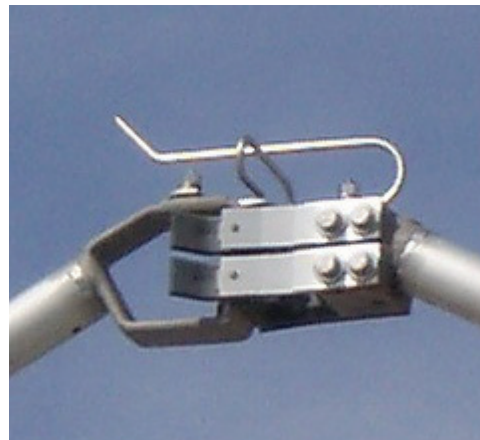

Quick Break Arcing Horns

The quick-break arcing horn is a device capable of interrupting a limited amount of line charging or transformer magnetizing current. The whip action, which produces a high-speed contact separation of the stationary and moving horns, limits the length of the arc and extinguishes the arc faster than conventional arcing horns. The interrupting ability of quick break arcing horns is limited, and will vary with atmospheric and operating conditions.



Vacuum Interrupter

The vacuum interrupter provides confined arc switching (in a vacuum) of load, line charging, and transformer magnetizing currents. The vacuum interrupter is capable of interrupting up to 2000 amperes at voltages 7.5kV through 230kV. At the higher voltages this interrupter utilizes vacuum units in series so interconnected that there is simultaneous separation of the contacts. Units are full voltage rated for interrupting duty up to the full continuous current rating of the main switch, with full open circuit voltage across the interrupter.





USCO™
Power Switches

OPERATING DEVICES

Swing Handle Operator

The swing handle control mechanism is a torsional type operator that uses a 3 ft galvanized steel pipe. The swing handle can be pad locked in both the open and closed position

- ❑ 180 degree rotation
- ❑ Required operating force <50 ft lbs



Worm Gear Operator

Standard gear operators are furnished with the specified ratings to reduce operating effort, and are also used to control the speed of operation of the switch. Gear operators are recommended for certain ratings when switches are equipped with quick break arcing horns. The standard USCO gear operator (30:1 gear ratio), has a worm gear, corrosion-free mechanism, with provisions for locking in the open and closed positions.



Motor Operator

Motor Operators are designed for electrical operation of air break switches from remote locations. They are available in a wide range of torque, operating speeds, and control voltages. Motor operators may be disconnected for manual operation of the switch during maintenance or emergencies, and for maintenance operation of the motor operator without operating the switch.



NOTES:





WORLDWIDE LOCATIONS

**Web: <http://www.uscopower.com>
<http://www.hubbellpowersystems.com>
E-mail: hpsliterature@hps.hubbell.com**

**UNITED STATES
CANADA, INTERNATIONAL**
HUBBELL POWER SYSTEMS, INC.
210 N. Allen Street
Centralia, Mo 65240-1395
Phone: 1-573-682-5521
Fax: 1-573-682-8714
e-mail: hpsliterature@hps.hubbell.com

MEXICO
HUBBELL DE MEXICO, S.A. DE C.V.
Av. Insurgentes Sur #1228, Piso 8
Col. Tlacoquemacatl Del Valle
Mexico, D.F. 03200
Phone: 52-55-9151-9999
Fax: 52-55-9151-9988
Website: hubbell.com.mx

BUSHINGS • CONSTRUCTION • INSULATION • PROTECTION • SWITCHING • TOOLS