

# GOSS<sup>®</sup>

MANUFACTURER OF TORCH TOOLS

*Choice of the Contractor*

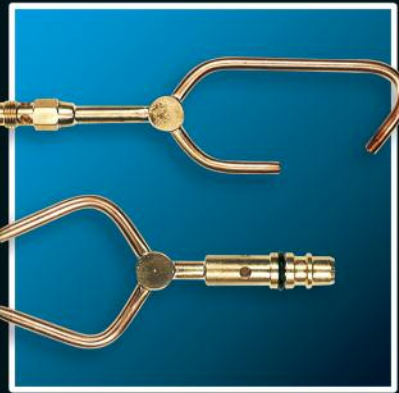
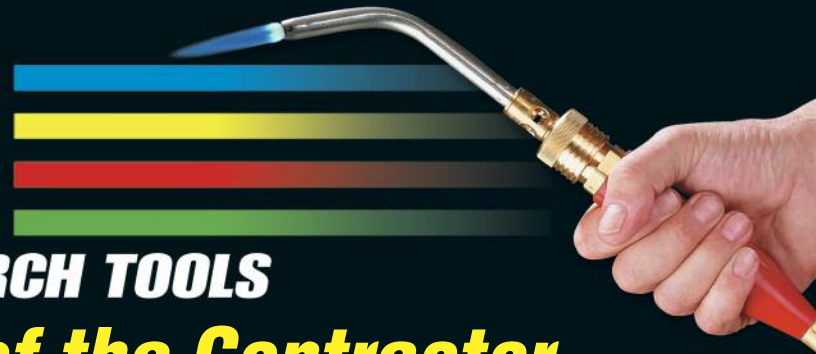

## EQUIPMENT CATALOG



**MANUFACTURER OF TORCH TOOLS**

Goss torches, regulators and accessories are known for having the highest quality, value and durability in the industry.

## **Experience**

Since 1940 Goss Inc. has been serving industry throughout the country and abroad with a full range of flame tools and accessories. Our reputation for quality, high performance products, excellent service and efficient distribution has made Goss a manufacturer that customers can depend on.

## **Goss Products**

Goss offers a wide variety of torches and accessories to fit any contractor's need. Our high quality Oxy-Fuel, Air-Acetylene, Air-Propane, MAP-Pro and Nitrogen equipment is individually tested and engineered for performance. A unique feature to Goss Air-Acetylene and Air-Propane tips is their one of a kind flame adjustability. We also provide high quality replacement cutting, welding, and heating tips for popular torches.

## **Quality & Durability**



In an independent 3rd party torch test reported by Plumbing & Mechanical Magazine, Goss torches and equipment were compared to other leading torches on the market. They concluded that, "The entire GOSS line proved to be the most indestructible."

## **Training & Customer Service**

Goss has a well established network of sales representatives and distributors who provide customers with many channels of support. They can provide training seminars, counter days, product assistance and additional product information. Contact our friendly customer service department to obtain more information on how we can serve you.

**GOSSWELD™ • FEATHER FLAME™ • TARGET TORCH™  
PRO-FLAME™ • EZE-Lite™**

GOSS INC. • 1511 Route 8 • Glenshaw, PA 15116-2301 • USA  
Phone: 1-800-367-4677 • 1-412-486-6100 • Fax: 1-412-486-6844



KA-125-M12P (shown)

**125 SERIES WELDING • BRAZING KITS**

The ideal kit for all your light duty welding/brazing needs. This outfit compatible for cutting by adding the TCA-10 cutting attachment.

- Welds to 3/16", brazes to 1-1/2"
- Torch, regulators and hose have size "A" fittings
- Durable construction
- UL listed components

*Available with or without cart or stand.*

KIT NO.	CYLINDER CONNECTION STAND OR CART	CONTENT FOR ALL 125 KITS
KA-125-M	MC Acet. Regulator	1 - TW-10A Torch Handle 1 - 3033-1 Weld Tip
KA-125-M12	MC Acet. Regulator & Steel Stand C-1200	1 - 3033-3 Weld Tip 1 - SW-12A Hose
KA-125-M12P	MC Acet. Regulator & Plastic Stand C-1200P	1 - MP-35 Goggles 1 - MP-1 Lighter
KA-125-B	B Acet. Regulator	1 - EO-25F-A Oxy Regulator 1 - EA-25-MA Regulator
KA-125-B13	B Acet. Regulator & Steel C-1300 Cart	or 1 - EA-25-BA Regulator



KA-325-M12P (shown)

**325 SERIES WELDING • BRAZING • CUTTING KITS**

This unique kit has a special adaptor which converts the welding torch to use lower temperature air/gas soldering and brazing tips.

- Special adaptor added to convert welding torch to use high temperature air/gas mix target tip
- Welds to 3/16", brazes to 1-1/2", cuts to 3/4"
- Torch, regulators and hose have size "A" fittings
- UL Listed components

*Available with or without cart or stand.*

KIT NO.	CYLINDER CONNECTION STAND OR CART	CONTENT FOR ALL 325 KITS
KA-325-M	MC Acet. Regulator	1 - TW-10A Torch Handle 1 - TCA-10 Cutting Attach.
KA-325-M12	MC Acet. Regulator & Steel Stand C-1200	1 - 3033-3 Weld Tip 1 - 2341-1 Cutting Tip
KA-325-M12P	MC Acet. Regulator & Plastic Stand C-1200P	1 - BA-10A Solder Tip 1 - SW-12A Hose
KA-325-B	B Acet. Regulator	1 - MP-35 Goggles 1 - MP-1 Lighter
KA-325-B13	B Acet. Regulator & Steel C-1300 Cart	1 - BRS-700 Adaptor 1 - EO-25F-A Oxy Regulator 1 - EA-25-MA Regulator
		or 1 - EA-25-BA Regulator

## 425 SERIES WELDING • BRAZING • CUTTING KITS

The best selection for the professional who needs both cutting and welding capabilities.

- Welding, brazing and cutting kits
- Welds to 3/16", brazes to 1-1/2", cuts to 3/4"
- Torch, regulators and hose have size "A" fittings
- UL Listed components

*Available with or without cart or stand.*

KIT NO.	CYLINDER CONNECTION STAND OR CART	CONTENT FOR ALL 425 KITS
KA-425-M	MC Acet. Regulator	1 - TW-10A Torch Handle 1 - TCA-10 Cutting Attach.
KA-425-M12	MC Acet. Regulator & Steel Stand C-1200	1 - 2341 Cutting Tip 1 - 3033-1 Weld Tip
KA-425-M12P	MC Acet. Regulator & Plastic Stand C-1200P	1 - 3033-3 Weld Tip 1 - SW-12A Hose
KA-425-B	B Acet. Regulator	1 - MP-35 Goggles 1 - MP-1 Lighter
KA-425-B13	B Acet. Regulator & Steel C-1300 Cart	1 - EO-25F-A Oxy Regulator 1 - EA-25-MA Regulator or 1 - EA-25-BA Regulator



KA-425-M12P (shown)

## 525 SERIES WELDING • BRAZING • HEATING KITS

Kit includes a wide variety of tips for a range of applications.

- Welding, brazing, heating kits
- Welds/brazes to 3-5/8"
- Torch, regulators and hose have size "A" fittings
- These kits include a heating tip for larger requirements
- UL Listed components

*Available with or without cart or stand.*

KIT NO.	CYLINDER CONNECTION STAND OR CART	CONTENT FOR ALL 525 KITS
KA-525-M	MC Acet. Regulator	1 - TW-10A Torch Handle 1 - 3033-1 Weld Tip
KA-525-M12	MC Acet. Regulator & Steel Stand C-1200	1 - 3033H-15 Heating Tip 1 - SW-12A Hose
KA-525-M12P	MC Acet. Regulator & Plastic Stand C-1200P	1 - MP-35 Goggles 1 - MP-1 Lighter
KA-525-B	B Acet. Regulator	1 - EO-25F-A Oxy Regulator 1 - EA-25-MA Regulator or 1 - EA-25-BA Regulator
KA-525-B13	B Acet. Regulator & Steel C-1300 Cart	



KA-525-M12P (shown)



KA-700-M (shown)

### 700 SERIES WELDING • BRAZING KITS

Stubby-Style Tips have a short, heavy duty design and give the user close up control while maximizing movement in tight area. Kits have many UL listed accessories and are prematched to different tank sizes. *Available with or without cart or stand.*

KIT NO.	CYLINDER CONNECTION STAND OR CART	CONTENT FOR ALL 700 KITS
KA-700-M	MC Acet. Regulator	1 - TW-5A Torch Handle 1 - 2033-1 Weld Tip
KA-700-M12	MC Acet. Regulator & Steel Stand C-1200	1 - 2033-3 Weld Tip 1 - SW-12A Hose
KA-700-M12P	MC Acet. Regulator & Plastic Stand C-1200P	1 - MP-35 Goggles 1 - MP-1 Lighter
KA-700-B	B Acet. Regulator	1 - EO-25F-A Oxy Regulator 1 - EA-25-MA Regulator
KA-700-B13	B Acet. Regulator & Steel C-1300 Cart	or 1 - EA-25-BA Regulator

## Front Valve Torch Kits with Standard-Style Tips, “A” Fittings



KA-725-B (shown)

### 725 SERIES WELDING • BRAZING KITS

- Front valve handle featured with standard size tips
- Kits are prematched to different tank sizes
- Rugged commercial design
- Weld to 3/16", braze to 1-1/2"
- UL listed accessories

*Available with or without cart or stand.*

KIT NO.	CYLINDER CONNECTION STAND OR CART	CONTENT FOR ALL 725 KITS
KA-725-M	MC Acet. Regulator	1 - TW-5A Torch Handle 1 - 3033-1 Weld Tip
KA-725-M12	MC Acet. Regulator & Steel Stand C-1200	1 - 3033-3 Weld Tip 1 - SW-12A Hose
KA-725-M12P	MC Acet. Regulator & Plastic Stand C-1200P	1 - MP-35 Goggles 1 - MP-1 Lighter
KA-725-B	B Acet. Regulator	1 - EO-25F-A Oxy Regulator 1 - EA-25-MA Regulator
KA-725-B13	B Acet. Regulator & Steel C-1300 Cart	or 1 - EA-25-BA Regulator

### 825 SERIES WELDING • BRAZING • CUTTING KITS

- Added cutting capacity in a compact design
- Tips included weld to 3/16", braze to 1-1/2", and cut to 3/4"
- Versatility that other torches can't match
- Kits are prematched to different tank sizes
- UL listed accessories

*Available with or without cart or stand.*



KA-825-B (shown)

KIT NO.	CYLINDER CONNECTION STAND OR CART	CONTENT FOR ALL 825 KITS
KA-825-M	MC Acet. Regulator	1 - TW-5A Torch Handle 1 - TCA-10 Cutting Attach.
KA-825-M12	MC Acet. Regulator & Steel Stand C-1200	1 - 2341-1 Cutting Tip 1 - 3033-1 Weld Tip
KA-825-M12P	MC Acet. Regulator & Plastic Stand C-1200P	1 - 3033-3 Weld Tip 1 - SW-12A Hose
KA-825-B	B Acet. Regulator	1 - MP-35 Goggles 1 - MP-1 Lighter
KA-825-B13	B Acet. Regulator & Steel C-1300 Cart	1 - EO-25F-A Oxy Regulator 1 - EA-25-MA Regulator
		or 1 - EA-25-BA Regulator

**COMMON FEATURES**

- Used by heating, cooling, refrigeration, repair shops and industry contractors
- Forged heads for durability
- Precise needle valve control\*
- Numerous tip sizes and styles available
- UL listed components

**TCA-10 CUTTING ATTACHMENT**  
Fits TW-10A and TW-5A

- 8" Long
- Uses 2341 Cutting Tips

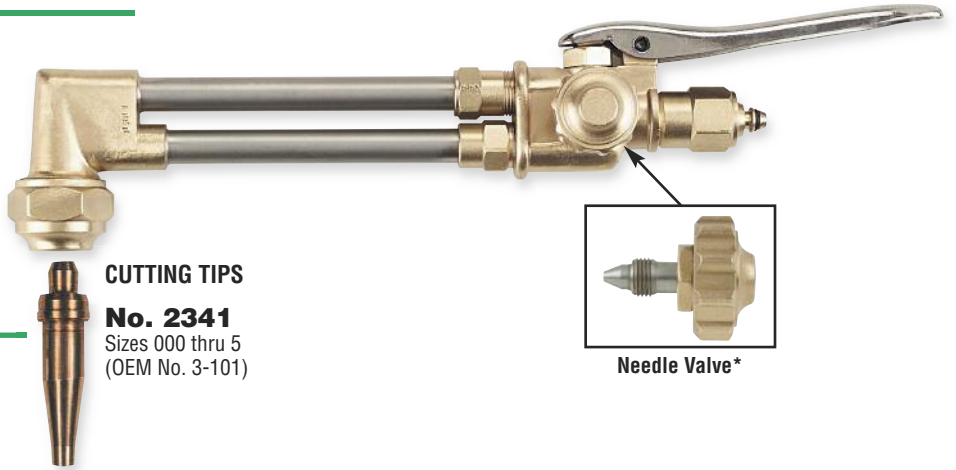

**CUTTING TIPS**  
**No. 2341**  
Sizes 000 thru 5  
(OEM No. 3-101)

Needle Valve\*

**TW-5A FRONT VALVE TORCH**  
"A" Hose Inlets

- 6" Long
- Uses 3033 Series and Stubby-Style Tips

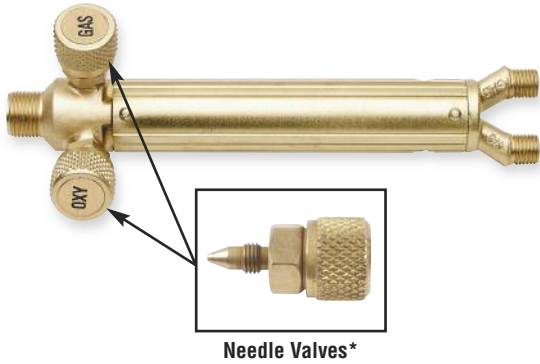

Needle Valves\*

**TW-10A WELDING TORCH**  
"A" Hose Inlets

- 7-3/4" Long
- Uses 3033 Series and Stubby-Style Tips

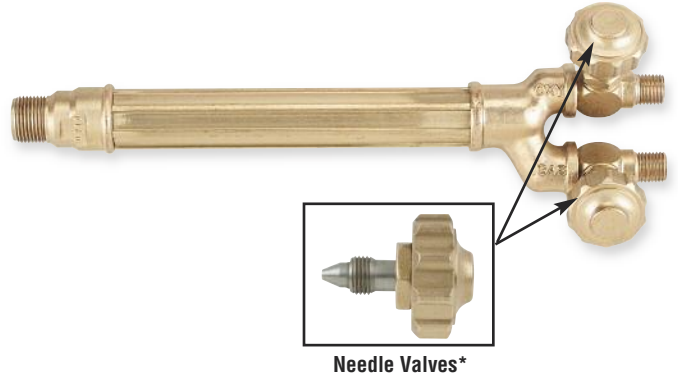

Needle Valves\*

**TIPS FOR TCA-10, TW-10A AND TW-5A TORCHES**

Standard Style Tips that provide extra reach and heat protection

**WELDING/BRAZING TIPS**



From 4" to 8" Long

**No. 3033**  
Sizes 000 thru 7

**HEATING/ROSEBUD TIPS**

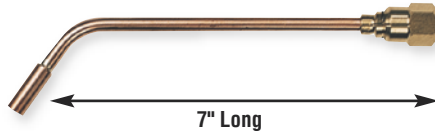

7" Long

**No. 3033H**  
Sizes 15, 30

**WELDING/BRAZING TIPS**



**No. 3033J**  
Sizes 1, 3

Stubby-Style Tips have a short heavy-duty design for applications needing a short profile

**WELDING/BRAZING TIPS**

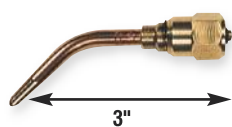

3"

**No. 2033**  
Sizes 000 thru 7

**HEATING TIPS**

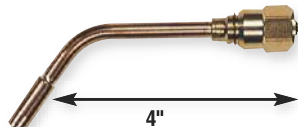

4"

**No. 2033H**  
Sizes 15, 30

**TWIN TIPS**



**No. 2066T**  
Sizes 00, 0, 1

**G-TIPS**



**No. 2077G**  
Sizes 00-3

See page 22 for brazing capacity.



**FUEL GAS REGULATORS**

MODELS	DESCRIPTION
EA-25-B	B Acet. (CGA 520) B Hose Fitting
EA-25-BA	B Acet. (CGA 520) A Hose Fitting
EA-25-M	MC Acet. (CGA 200) B Hose Fitting
EA-25-MA	MC Acet. (CGA 200) A Hose Fitting
EA-25-CA	Comm. Acet. (CGA 300) A Hose Fitting
EP-25A	POL LP/ Acet. (CGA 510) A Hose Fitting

**GOSSWELD® REGULATORS**

These UL listed regulators are manufactured from durable brass and include easy to read gauges, sintered inlet filters, and replaceable inlet and outlet fittings. Goss regulators give the constant and accurate gas flow needed by professionals.

EO-25F-A (shown)

**OXYGEN REGULATORS**

MODELS	DESCRIPTION
EO-25F-A	Oxygen (CGA 540) A Hose Fitting
EO-25F	Oxygen (CGA 540) B Hose Fitting

**REVERSE FLOW CHECK VALVES**

- JP-19 Oxy Fuel Set, "A" Fittings
- JP-25 Oxy Fuel Set, "B" Fittings

- Prevents the reverse flow of gases
- Connect directly to torch inlets
- Available with "A" or "B" fittings

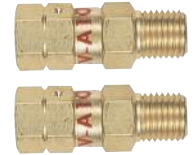

**TWIN HOSE**

ACETYLENE, GRADE "R" HOSE	
SW-8A	8' (A) Fittings 3/16" ID
SW-12A	12' (A) Fittings 3/16" ID
SW-25A	25' (A) Fittings 3/16" ID

LP AND ACETYLENE, GRADE "T" HOSE	
SWT-12A	12' (A) Fittings 3/16" ID
SWT-12B	12' (B) Fittings 3/16" ID



**CARTS & STANDS**

• 1200 series is available in either Steel or Plastic



**C-1200P**  
Heavy Duty  
Plastic Stand for  
20 cu. ft. Oxy. &  
10 cu. ft. MC Acet.



**C-1200**  
Steel Stand for  
20 cu. ft. Oxy. &  
10 cu. ft. MC Acet.

**C-1100**  
Steel Stand for  
40 cu. ft. Oxy. &  
40 cu. ft. B Acet.



**C-1300**  
Steel Cart for  
40 cu. ft. Oxy. &  
40 cu. ft. B Acet.



KA-1H (shown)

## FEATHER FLAME® KITS & TIPS

"Screw-in Style"

These kits include our most economically priced air-acetylene tips. Their design makes them inexpensive while still producing excellent flame characteristics.



- Pencil Point/Feather Flame
- Adjustable flame feature
- Tips have a filter and removable orifice
- Heavy-duty UL listed regulator

KIT NO.	TIP NO.	REG. FTG
KA-1H	BA-3	"B" Cylinder
KA-2H	BA-3	"MC" Cylinder
KA-31*	BA-2, BA-3, BA-4	"B" Cylinder
KA-32*	BA-2, BA-3, BA-4	"MC" Cylinder
KA-37H*	BA-4	"B" Cylinder
KA-38H*	BA-4	"MC" Cylinder

TIP NO.	TIP SIZE	SOFT SOLDER
BA-1	1/16"	1/16" - 1/8"
BA-2	1/8"	1/8" - 1/4"
BA-3	3/16"	1/4" - 1/2"
BA-4	1/4"	1/2" - 1"
BA-5	5/16"	1" - 1-1/2"
BA-6	7/16"	2" - 4"

Contents: HA3-12 hose, regulator, AA-1 handle, MP-1 lighter and MA-2 wrench.  
\*These kits DO NOT include lighter.



## TARGET® KITS & TIPS

"Screw-in Style"

Kits feature the adjustable Target Tips for professional soldering and brazing applications. These tips are very hot and have a compact flame. Kits also include a screw-in handle, 12 ft. hose and UL listed regulator.



- **MaXPerformance** Turbine Flame
- Adjustable flame feature
- Unique mixer design reduces brazing time over conventional tips
- Tips have a filter and removable orifice
- Interchangeable with other screw-in style tips and equipment
- Made of heavy gauge stainless steel and brass

KIT NO.	TIP NO.	REG. FTG
KA-3H	BA-10A	"B" Cylinder
KA-4H	BA-10A	"MC" Cylinder
KA-7H*	BA-9A, BA-12A	"B" Cylinder
KA-8H*	BA-9A, BA-12A	"MC" Cylinder

TIP NO.	TIP SIZE	SOFT SOLDER	SILVER BRAZE
BA-9A	1/4"	Up to 1"	1/8" - 1/2"
BA-10A	3/8"	Up to 2"	1/2" - 1"
BA-12A	1/2"	Up to 4"	1" - 2"

Contents: HA3-12 hose, regulator, AA-1 handle, MP-1 lighter and MA-2 wrench.  
\*These kits DO NOT include lighter. All kits are currently blister packed.



KX-3B (shown)

## TARGET® KITS & TIPS

"Snap-in Style"

Kits feature the adjustable Target Tips for professional soldering and brazing applications. These tips are very hot and have a compact flame. Kits also include a quick disconnect handle, 12 ft. hose and UL listed regulator.

Choose from a wide selection of kits below.



- **MaX Performance** Turbine Flame
- Adjustable flame feature
- Unique mixer design reduces brazing time over conventional tips
- Tips have a filter and removable orifice
- Interchangeable with other quick disconnect style tips and equipment
- Made of heavy gauge stainless steel and brass

KIT NO.	TIP NO.	REG. FTG
KX-3B	GA-3, GA-11	"B" Cylinder
KX-4B	GA-5, GA-14	"B" Cylinder
KX-5B	GA-5	"B" Cylinder
KX-5MC	GA-5	"MC" Cylinder
KX-6MC	GA-3, GA-8	"MC" Cylinder
KX-7B	GA-8	"B" Cylinder

Contents: HA3-12 hose, GG-4 handle, tip(s), MA-2 wrench and regulator.

TIP NO.	TIP SIZE	SOFT SOLDER	SILVER BRAZE
GA-2	3/16"	1/8" - 1/2"	1/8" - 1/4"
GA-3	1/4"	1/4" - 1"	1/8" - 1/2"
GA-5	5/16"	3/4" - 1-1/2"	1/4" - 3/4"
GA-8	3/8"	1" - 2"	1/2" - 1"
GA-11	7/16"	1-1/2" - 3"	7/8" - 1-5/8"
GA-14	1/2"	2" - 4"	1" - 2"
GA-32	3/4"	4" - 6"	1-1/2" - 4"



KX-10B (shown)

## EZE-LITE™ INSTANT IGNITION KITS & TIPS

"Snap-in Style"

Kits feature EZE-Lite push button ignition tips with a turbine swirl action flame. Also featured is the quick disconnect handle, 12 ft. hose and UL listed regulator.

Kits are prematched to different tip and tank sizes.

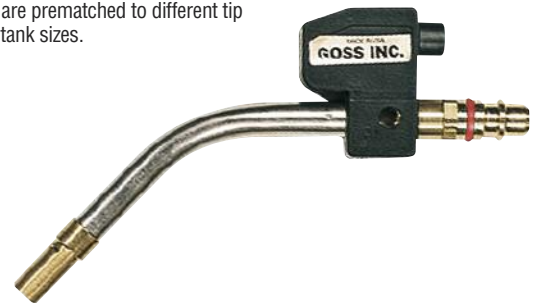

- **MaX Performance** Turbine Flame
- Tip ignites with the push of a button
- Tips have a filter and removable orifice
- Interchangeable with other quick disconnect style tips and equipment

KIT NO.	TIP NO.	REG. FTG
KX-10B	GA-5L	"B" Cylinder
KX-10MC	GA-5L	"MC" Cylinder
KX-15B	GA-8L	"B" Cylinder
KX-15MC	GA-8L	"MC" Cylinder

Contents: HA3-12 hose, GG-4 handle, tip, MA-2 wrench and regulator.

TIP NO.	TIP SIZE	SOFT SOLDER	SILVER BRAZE
GA-3L	1/4"	Up to 1"	Up to 1/2"
GA-5L	5/16"	Up to 1-1/2"	Up to 3/4"
GA-8L	3/8"	Up to 2"	Up to 1"
GA-14L	1/2"	Up to 4"	Up to 2"



## SIDEWINDER™ KITS WITH WHEELED CARTS

Fit "B" Acetylene Cylinders

### Part No. KX-3BCW (shown)

Cart/Kit Combo  
C-850CW Cart  
Heavy-duty GG-4 Torch Handle  
Max Performance GA-3 & GA-11 Tips  
"B" Regulator, 12' Hose & Wrench

### Part No. KX-10BCW

Cart/Kit Combo  
C-850CW Cart  
Heavy-duty GG-4 Torch Handle  
Piezo Ignition GA-5L EZE-LITE Tip  
"B" Regulator, 12' Hose & Wrench

### Part No. KX-5BCW

Cart/Kit Combo  
C-850CW Cart  
Heavy-duty GG-4 Torch Handle  
Max Performance GA-5 Tip  
"B" Regulator, 12' Hose & Wrench

### Part No. KA-37HCW

Cart/Kit Combo  
C-850CW Cart  
Heavy-duty AA-1 Torch Handle  
Feather Flame BA-4 Tip  
"B" Regulator, 12' Hose & Wrench

## SIDEWINDER™ KITS WITH STANDS

Fit "B" Acetylene Cylinders

### Part No. KX-3BS

Carry/Kit Combo  
C-850 Stand  
Heavy-duty GG-4 Torch Handle  
Max Performance GA-3 & GA-11 Tips  
"B" Regulator, 12' Hose & Wrench

### Part No. KX-10BS

Carry/Kit Combo  
C-850 Stand  
Heavy-duty GG-4 Torch Handle  
Piezo Ignition GA-5L EZE-LITE Tip  
"B" Regulator, 12' Hose & Wrench

### Part No. KX-5BS

Carry/Kit Combo  
C-850 Stand  
Heavy-duty GG-4 Torch Handle  
Max Performance GA-5 Tip  
"B" Regulator, 12' Hose & Wrench

### Part No. KA-37HS (shown)

Carry/Kit Combo  
C-850 Stand  
Heavy-duty AA-1 Torch Handle  
Feather Flame BA-4 Tip  
"B" Regulator, 12' Hose & Wrench



## INDIVIDUAL SIDEWINDER™ CARTS AND STANDS

Fit "B" AND "MC" Acetylene Cylinders

### Part No. C-850CW

"B" Acetylene Cart  
Made of Heavy-duty Steel  
Hose Rack & Torch/Tip Holder  
Detachable Handle  
Steel Wheels

### Part No. C-850 "B" Acetylene Stand

### Part No. C-800 "MC" Acetylene Stand

Made of Heavy-duty Steel  
Hose Rack & Torch/Tip Holder





AA-1



AA-3



GG-4

## ACET-O-LITE® "Screw-in Style"

AA-1 has the adjustment valve in the front for single hand operation, the AA-3 has the valve in the rear for fingertip control. Needle valve design enables very fine flame adjustments. *These torches will keep your tips burning efficiently in drafts, winds, and adverse conditions.* Both torches are made with quality brass, have very durable handles and use standard 3/8-24 LH "A" size hose fittings.

Goss Acet-O-Lite torches work with all "BA" style tips listed on page 7.

## TARGET TORCH® "Snap-in Style"

This handle has a quick disconnect fitting to rapidly change tips. Comfortable grooved handle is made of very durable materials. Uses 3/8-24 LH "A" jps fittings.

Goss Target Torch handle will work with all "GA" style tips listed on page 8.

## SPECIALTY TIPS "Snap-in Style"

SNAP-IN design used with GG-4 handle. Duel feather flame design for special applications. Also available with screw-in style: BA-TT and BA-GT.

### SPLIT-FIRE® TIPS

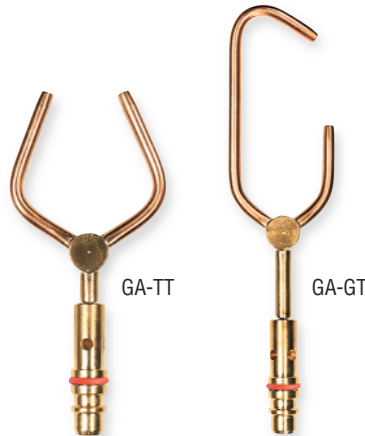

TIP NUMBER	FLAME DIAMETER	SOFT SOLDER	SILVER BRAZING
BA-TT	(2) 1/4"	3/4"	3/4"
BA-GT	(2) 1/4"	3/4"	3/4"
GA-TT	(2) 1/4"	3/4"	3/4"
GA-GT	(2) 1/4"	3/4"	3/4"
GA-3J	1/4"	1/4" to 1"	1/8" to 1/2"
GA-8J	3/8"	1" to 2"	1/2" to 1"

 **COLOR-CODED "O" RINGS**  
Red for Acetylene

## "Snap-in Style"

The J-Tip design allows you to solder or braze in hard-to-reach areas while safely pointing the flame away from flammable surfaces.

### J-Tips



## ACETYLENE REGULATORS

These UL LISTED regulators, manufactured of solid brass, are made for rugged use. *They have a specially designed conical seat and diaphragm.* The inlets have filters to prevent dirt from entering the regulator.

**EA-1G** B cyl. connection; "A" Hose fitting 3/8 - 24 L.H.

**EA-2G** MC cyl. connection; "A" Hose fitting 3/8 - 24 L.H.

**GAUGE ONLY**  
Part No.  
MA-80-16

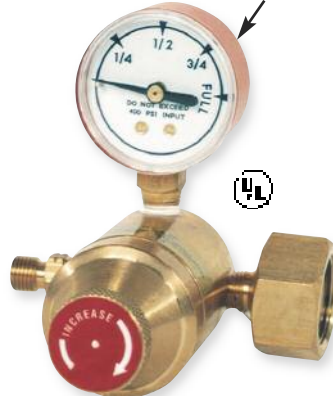
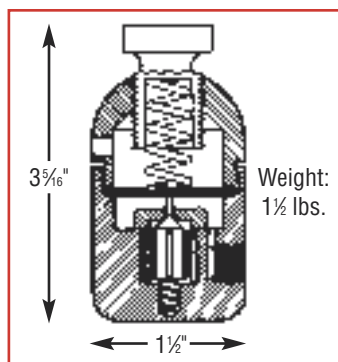

## ACETYLENE HOSE

Hose assemblies are made of quality 7/16" OD x 3/16" ID single ply fabric reinforced Grade R hose.

*It has a 200 PSI working pressure.*

**HA3-6** Hose 6 feet long with "A" (3/8 - 24) connections

**HA3-12** Hose 12 feet long with "A" (3/8 - 24) connections

**HA3-25** Hose 25 feet long with "A" (3/8 - 24) connections





KP-102 (shown)



KP-115 (shown)



KLP-4 (shown)

## PROPANE KITS WITH PENCIL AND BRUSH TIPS

Kits contain a complete selection of high quality soldering and heating equipment.

KIT NO.	TIP NO.
KP-102	BP-2
KP-105	BP-5

*Kits include: AP-1 handle, EP-70G regulator, MP-1 lighter and HEF-10 hose and tip listed.*



- Quiet, adjustable brush flame
- Fits AP-1 handle

TIP NO.	FLAME	DIAMETER	SOFT SOLDER	BTU's @ 40 psi
BP-1	Pencil	5/8"	To 1/2"	6,000
BP-2	Pencil	1"	To 1-1/2"	11,000
BP-3	Brush	7/8"	To 2"	14,000
BP-4	Brush	1-1/8"	To 3"	43,000
BP-5	Brush	1-3/8"	To 4"	57,000
BP-6	Brush	2"	To 6"	300,000

## TARGET® PROPANE KITS AND TIPS "Screw-in Style"

Screw-in style kits feature the very hot, compact Target Tips. Kits also include a handle, UL listed regulator and accessories.

KIT NO.	TIP NO.
KP-115	BP-15PM
KP-115L*	BP-15PML*
KP-117	BP-17PM

*Kits include: AP-1 handle, EP-70G regulator, MP-1 lighter and HEF-10 hose and tip listed.*

\*Instant Igniter



- **MaX** Performance Turbine Flame
- Screw-in design
- Fits AP-1 handle

TIP NO.	FLAME DIAMETER	SOFT SOLDER	SILVER BRAZE
BP-13PM	7/16"	To 1"	1/2"
BP-15PM	1/2"	To 1-1/2"	3/4"
BP-15PML*	1/2"	To 1-1/2"	3/4"
BP-17PM	3/4"	To 2-1/2"	1-1/2"

## TARGET® PROPANE KITS AND TIPS "Snap-in Style"

Snap-in style kits feature the very hot, compact Target Tips for professional soldering and brazing applications. Kits also include a quick disconnect handle, UL listed regulator and accessories.

KIT NO.	TIP NO.
KLP-2	GT-3, GT-5
KLP-4	GT-4
KLP-4L*	GT-4L*

*Kits include: GH-4 handle, HEF-10 hose, EP-70G regulator and torch tip(s).*

\*Instant Igniter



- **MaX** Performance Turbine Flame
- Tips have a filter and removeable orifice
- Interchangeable with other quick disconnect style tips and equipment
- Tips fit GG-4 handle
- Color-coded O-rings

TIP NO.	FLAME DIAMETER	SOFT SOLDER	SILVER BRAZE
GT-2	5/16"	Up to 1/2"	Up to 1/4"
GT-2J	5/16"	Up to 1/2"	Up to 1/4"
GT-3	7/16"	Up to 1"	Up to 1/2"
GT-4	1/2"	Up to 1-1/2"	Up to 3/4"
GT-4L*	1/2"	Up to 1-1/2"	Up to 3/4"
GT-5	3/4"	Up to 2-1/2"	Up to 1-1/4"



AP-1

## TORCH HANDLE "Screw-in Style"

Comfortable handle design reduces operator fatigue. Up front valve offers single-handed operation.

**This handle accepts all screw-in tips shown on page 11.**

**Uses HEF hose shown below. 9/16-L.H., "B" hose fitting.**



GH-4

## TORCH HANDLE "Snap-in Style"

Curved handle provides positive grip. Precision machined needle valve allows greater range of flame control. Utilizes quick disconnect for fast tip change over.

**This handle accepts all snap-in tips shown on page 11 & 12.**

**Uses HEF hose shown below. 9/16-L.H., "B" hose fitting.**

## SPECIALTY TIPS "Snap-in Style"

TIP NUMBER	FLAME DIAMETER	SOFT SOLDER	SILVER BRAZING
GT-4L*	1/2"	1-1/2"	3/4"
GT-G	(2) 3/8"	3/4"	3/4"
GT-2J	5/16"	3/4"	3/8"

 **COLOR-CODED "O" RINGS**  
Blue for Propane

\*Instant Igniter



GT-4L



GT-G



GT-2J

## HOSE

### VAPOR PROPANE GAS HOSE

Quality flexible hose utilizes the standard 9/16-18 LH hose fittings.

**Working pressure: 350 PSI.**  
**Outside diameter: 9/16"**  
**Inside diameter: 1/4"**

HOSE NO.	LENGTH (ft.)
HEF-6	6
HEF-10	10
HEF-12	12
HEF-20	20
HEF-25	25
HEF-35	35
HEF-50	50



*Not for use with Natural Gas.*

### VAPOR PROPANE / MAP-Pro™ / NATURAL GAS HOSE

Quality flexible hose for use with multiple gases. 9/16-18 LH hose fittings.

**Working pressure: 200 PSI.**  
**Outside diameter: 7/16"**  
**Inside diameter: 3/16"**

HOSE NO.	LENGTH (ft.)
HP3-12	12



*Grade "T" hose.*

## PROPANE REGULATORS

### HIGH PRESSURE

**Use only with vapor withdrawal cylinders.**

**All brass regulators used with propane torches and furnaces.**

Adjustable pressure from 5 to 60 PSI. UL Listed with POL inlet spud and nut, 1/4" NPT openings, and 9/16 - 18 LH hose outlet.

**EP-70G** Has 0 to 60 PSI outlet pressure gauge for propane gas.

**EP-80G** Has 0 to 70 PSI outlet pressure without gauge for propane gas.

**XP-234** Regulator with dust cap and heavy duty inlet nut for propane gas.



EP-70G

### LOW PRESSURE

**For vapor withdrawal cylinders.**

This regulator has approx. 6-7 oz. or 11" water column outlet pressure and is for applications requiring low gas pressure. UL LISTED with 1/4" NPT inlet and 3/8" NPT outlet. **Do not use with any Goss LP torch or furnace equipment.**

**EP-60 - 0** Body only, no fittings.

**EP-60 - 1** POL inlet, 3/8" flare outlet.

**EP-60 - 2** POL inlet, 1/4" flare outlet.

**EP-60 - 3** POL inlet, LH hose outlet.

**EP-60 - 4** T-Block inlet, 3/8" flare outlet.

**EP-60 - 5** POL inlet less outlet.



### GP-360 TORCH ACCESSORIES

**EP-20BR** Regulator for disposable cylinder with (B) hose outlet connection.

**EP-20R** (Not pictured) Regulator body with Swivel Stem for the GP-360 Series torch.

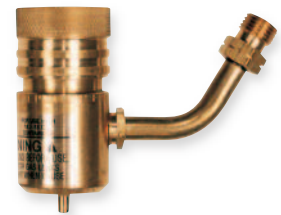

### LOW PRESSURE WITH OPD TANK CONNECTION

**For vapor withdrawal cylinders.** Same features as the EP-60 regulators except it utilizes an OPD cylinder connection.

**EP-90 - 1** Type 1 inlet, 3/8" flare outlet.

**EP-90 - 2** Type 1 inlet, 1/4" flare outlet.

**EP-90 - 3** Type 1 inlet, LH hose outlet.

**EP-90 - 4** T-Block inlet, 3/8" flare outlet.

**EP-90 - 5** Type 1 inlet, less outlet.



## GP-360 HAND TORCHES FOR DISPOSABLE CYLINDERS

- **MaX**Performance Turbine Flame
- Professional duty torch
- Tip swivels 360°
- Added filter to eliminate orifice clogging
- Adjustable brass regulator
- Uses MAP-Pro™, propane or FG2 gases

TORCH NUMBER	FLAME DIAMETER	SOFT SOLDER	SILVER BRAZING
GP-360R Regular Size	1/2"	1/4" to 2-1/2"	1/4" to 1-1/4"
GP-360L Igniter Torch	1/2"	1/4" to 2-1/2"	1/4" to 1-1/4"
GP-360J J Style Igniter Torch	3/8"	1/4" to 3/4"	1/4" to 3/8"
GP-360JL J Igniter Torch	1/2"	1/4" to 2-1/2"	1/4" to 1-1/4"
GP-360SS Super Size	3/4"	1" to 4"	1" to 2"

Measured using MAP-Pro™ gas.  
Now in clamshell packaging.



## "SIDEWINDER KITS"

### KP-26: Snap-In Style Handle

Contents: EP-20BR Regulator, GH-4 Handle, GT-4 Target Tip, MP-1 Lighter, HP3-12 Hose, C-500 Stand.

### KP-26NS: Snap-In Handle

Contents: Same as KP-26 except without stand.

### KP-26L: Snap-In Handle with Igniter Tip

Contents: Same as KP-26 except includes GT-4L Igniter Tip.

### KP-26LNS: Snap-In Handle with Igniter Tip

Contents: Same as KP-26L except without stand.

### KP-27: Screw-In Style Handle

Contents: EP-20BR Regulator, AP-1 Handle, BP-15PM Target Tip, MP-1 Lighter, HP3-12 Hose, C-500 Stand.

### KP-27L: Screw-In Handle with Igniter Tip

Contents: Same as KP-27 except includes BP-15PML Igniter Tip.

### FEATURES:

- Has 12 ft. of hose
- Utilizes Goss Target Tips on both model of kits
- Spare cylinder storage
- Hose hanger for Sidewinder storage
- Available with Piezoelectric igniter tip

**C-500 Stand only**



KP-26 Kit, with stand

Cylinders not included, see page 19.

## GP-600 SELF-IGNITING HAND TORCH FOR DISPOSABLE CYLINDERS

- **MaXPerformance** increases flame temperature by 40%
- Very hot turbine flame
- Easily adjustable from a large to small flame
- Replacement tip end
- Durable construction
- Uses MAP-Pro™ or propane fuel

### ADJUSTABLE FLAME FEATURE



**Instant Ignition** ⚡

## TRIGGER TORCH

Professional Duty Torch for Soldering and Brazing

SOFT SOLDER	SILVER BRAZING
1/4" - 3-1/2"	1/4" - 1-1/4"

Measured using MAP-Pro™ gas.



**BP-22LTE**  
Replacement Tip End for GP-600

**Lights with the Squeeze of a Button** ⚡

## HAND TORCHES FOR DISPOSABLE CYLINDERS

### GP-6

**Economy Torch**  
Propane only

- Used only with propane gas
- Economically priced and practical for light duty jobs
- Flame control valve gives precise adjustments
- Durable brass construction
- Can be used inverted once tip end becomes warm

### GP-9

**Heavy Duty Torch**  
Propane / MAP-Pro™

Made of the finest brass materials, this torch has soft soldering capabilities and is a popular choice for plumbing, heating, electrical and many other uses.

- A tip that can be used with propane or MAP-Pro™ gas without changing the orifice
- Easily adjusted to three different flames without changing tip ends
- Attractively packaged for pegboard display
- Can be used inverted once tip end becomes warm

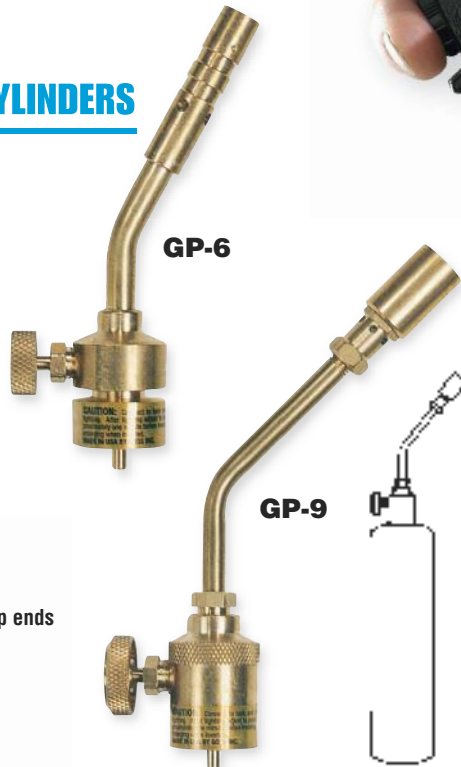

## LEAK DETECTOR

Use with disposable propane or MAP-Pro™ gas cylinders.

The flame, when adjusted to heat the reactor plate, quickly changes color as the search hose passes a leak of refrigerant gas.

- 24" search hose
- Blackened shell to easily observe flame color
- Replacement parts available

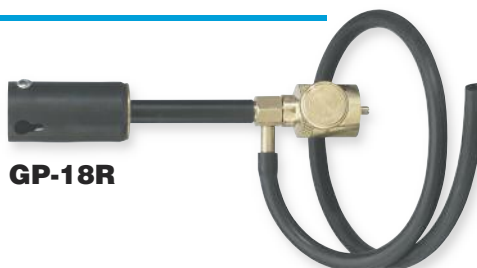

Cylinders not included, see page 19.



## BLAZEBURNER TORCH KITS & TORCHES

This equipment can be used for weed burning, drying, heating, melting and other applications requiring large volumes of outdoor heat. Each uses vapor propane fuel and has a durable handle with rear on/off control valve. Used by contractors, farmers, fabricators as well as road, railway and industrial maintenance crews.

See regulators and hoses on page 12.

### KP-320

Contents: AP-20 Torch, EP-80G Regulator, HEF-10 Hose and MP-1 Lighter.

### KP-320M

Contents: Same as above with BPS-8M Piezoelectric Igniter Tip.

### KP-320A

Contents: AP-20 Torch, MP-1 Lighter, HPX-10, 10 ft. Hose with Cylinder Adaptor.

### ⚡ KP-320MA (shown)

Contents: AP-20 Torch with Piezoelectric Igniter Tip, HPX-10, 10 ft. Hose with Cylinder Adaptor.

### KP-320ACW

Contents: Same as KP-320A with C-1400 cart. Shipped in two boxes.

### ⚡ KP-320MACW

Contents: Same as KP-320MA with C-1400 cart. Shipped in two boxes.

## TORCHES WITH STEEL BURNER

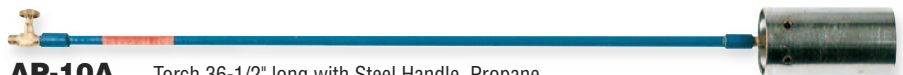

**AP-10A** Torch 36-1/2" long with Steel Handle, Propane.

### KP-100 Kit

Contents: AP-10A Torch, HEF 10 ft. Hose, IP-2.

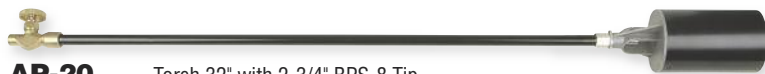

**AP-20** Torch 32" with 2-3/4" BPS-8 Tip.



**AP-20M** Torch 32" with 2-3/4" BPS-8M Piezo Ignition Tip.



**AP-25N** For Natural Gas Only.

## TORCH WITH CAST IRON BURNER



**AP-14** Blue-Jet Torch for Propane Only.

### KP-14R Kit

Contents: AP-14 Torch, HEF 10 ft. Hose, EP-80G Regulator.

TORCH NO.	TOTAL LENGTH (INCHES)	WEIGHT (LB.)	APPROX. BTU's MAX	APPROX. GAS USAGE @ 70 psi (LB./HR.)	TIP	TIP DIAMETER (INCHES)
AP-10A	36-1/2	3-1/4	500,000	20	BP-8TE	3
AP-14	27	5-1/2	300,000	20	BP-10	2-3/8
AP-20	32	1-3/4	500,000	20	BPS-8	2-3/4
AP-20M	32	1-3/4	500,000	20	BPS-8M	2-3/4
AP-25N	31	1-3/4	500,000	20	BP-6TEN	2

## CAUTION:

This equipment is an unvented device not designed for use indoors and **MUST NOT** be used in an enclosed area. **DO NOT** leave equipment operating unattended.

Follow operating instructions included with this equipment. Use in accordance with all Federal, State and local regulations.

## WHEELED CART

### C-1400 (Cart only)

Steel constructed cart with wheels for your 20 lb. propane tank. (Cylinder not included)



## READY-FLAME COMBINATION TORCHES FOR ROOFING, HEATING & HEAT SHRINKING

**AP-54**

Designed for continuous or intermittent use. At the squeeze of a lever, operator can go from pilot flame to full-brush flame as needed. Has adjustable pilot valve.







**AP-99R**

Has same quality construction and versatile features as all Ready-Flame Torches but without pilot valve and lever flame control.

*Match tips and extensions below for your needs or see complete kits at bottom of page.*

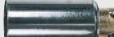
## TIP ENDS FOR EXTENSIONS

Engineered to provide a variety of heat and flame characteristics when combined with the handles and extensions on this page.

TIP NO.	FLAME	DIAMETER	BTU's @ 40 psi
<b>BP-2TE</b> 	Pencil*	1"	11,000
<b>BP-3TE</b> 	Brush*	7/8"	14,000
<b>BP-4TE</b> 	Brush*	1-1/8"	43,000
<b>BP-5TE</b> 	Brush*	1-3/8"	57,000
<b>BP-6TE</b> 	Brush*	2"	300,000
<b>BP-66</b> <i>Piezoelectric ignitor tip.</i> 	Brush*	2"	300,000
<b>BP-8TE</b> 	Brush*	3"	300,000

\*For propane or MAPP/Pro™ gas.

## BRASS EXTENSIONS FOR TORCHES

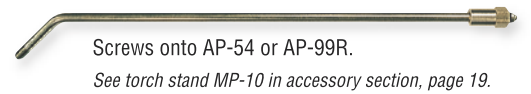

EXTENSION	DESCRIPTION (INCHES)
EX-4B	4" Bent
EX-12B	12" Bent
EX-12S	12" Straight
EX-18B	18" Bent
EX-18S	18" Straight
EX-18DB	18" Double Head Bent
EX-18DS	18" Double Head Straight
EX-24B	24" Bent
EX-30B	30" Bent

## HEAT SHRINK TIP

Screws onto both AP-54 or AP-99R torch. This tip has a short, wide soft flame used for heat shrinking plastics.

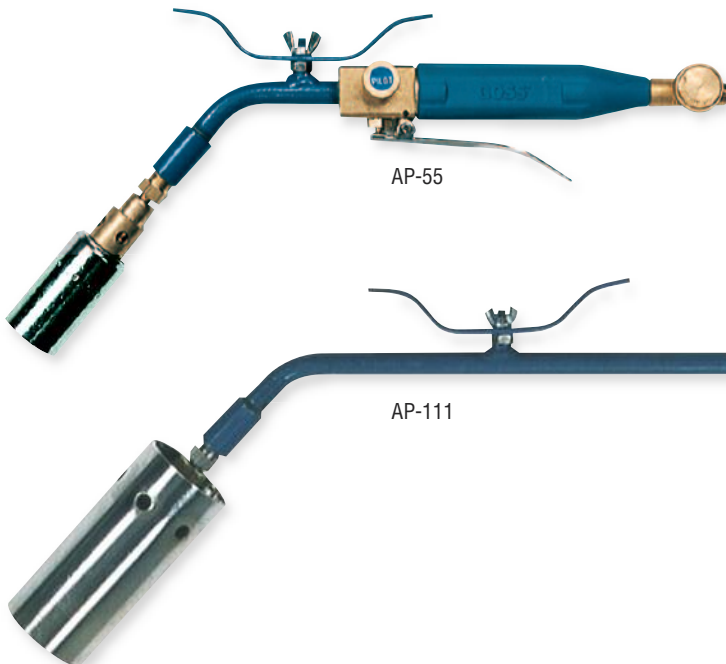

## ASSEMBLED STEEL EXTENSION TORCHES

Used for applications requiring large volumes of heat. Each has a steel extension and an adjustable pilot valve. At the squeeze of a lever, operator can go from pilot flame to full-brush flame.

**AP-55**

Length 16", with BP-5TE Tip.

**AP-111**

Length 30", with BP-6TE Tip.

**AP-111M**

Length 30", with BP-66 Push Button Piezoelectric Tip (Not Shown).

## STEEL EXTENSION KITS (Not Shown)

**KP-155-H:**

Contents: AP-55 Torch, MP-1 Lighter, HEF-20 Hose, EP-80G Regulator.

**KP-318M-H:**

Contents: AP-111M Piezo Ignition Torch, HEF-25 Hose, EP-80G Regulator.

**KP-318-H:**

Contents: AP-111 Torch, MP-1 Lighter, HEF-25 Hose, EP-80G Regulator.

## OUTDOOR FURNACES



### FLOOR FURNACE\*

#### FP-540

A well-constructed lead melting furnace with brush flame burner.

**BTUs** Approx. 43,200  
**Gas Usage** Approx. 2 lb./hr.  
**Height** 8 in.  
**Weight** 8 lb.  
**Diameter** 8-1/2 in.

\*For propane only.

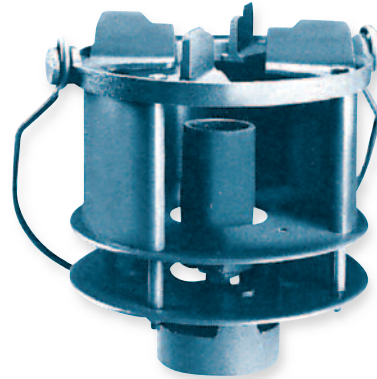

### CYLINDER MOUNTED FURNACE\*

#### FP-600

Easily attached or removed without tools.

**BTUs** Approx. 43,200  
**Gas Usage** Approx. 2 lb./hr.  
**Height** 8-3/4 in.  
**Weight** 9 lb.  
**Diameter** 8-1/2 in.

\*For propane only.

## WIND SHIELDS

(For all furnaces above)



#### FP-S1

Straight wind shield.  
 Diameter: 7-5/8 in.



#### FP-S2

Spun wind shield.  
 Top Diameter: 9-1/8 in.

## LEAD POT & LADLE



#### MP-3

7 in. diameter cast iron lead pot.  
 Holds 50 lb. of lead.



#### MP-5

3 in. diameter cast iron ladle



KP-25 (shown)

## SOLDERING IRON

- Adjustable Pencil Point Flame
- Replaceable Copper Ends
- Durable Steel Construction
- Removeable Stand

### KP-25

**Kit includes:** DP-11 Soldering Iron, DP-9A Copper Tip, HEF-10 LP Hose, EP-80G Regulator, MP-1 Lighter.



- DP-9** Complete soldering iron with small pyramid copper
- DP-9A** Small pyramid copper only – 3/4 in. diameter
- DP-10** Complete soldering iron with small chisel copper
- DP-10A** Small chisel copper only – 3/4 in. diameter
- DP-11** Complete soldering iron with large pyramid copper
- DP-11A** Large pyramid copper only – 1-1/4 in. diameter
- DP-12** Complete soldering iron with large chisel copper
- DP-12A** Large chisel copper only – 1-1/4 in. diameter

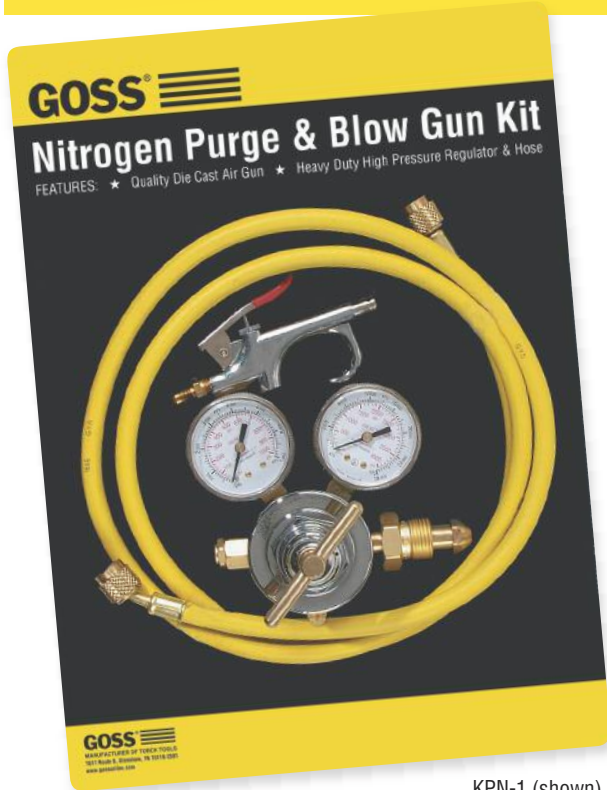

KPN-1 (shown)

## NITROGEN PURGE & BLOW GUN KIT

- 6 ft. / 1/8m Hose
- EN-460F High Pressure Regulator
- Quality Die-cast Blow Gun
- Multiple Uses: Purges, Blow, Leak Tests
- Add Stands to KPN-1 Kit:
  - KPN-20S Includes Blow Gun Kit and Stand for 20 Cubic ft. Cylinders
  - KPN-40S Includes Blow Gun Kit and Stand for 40 Cubic ft. Cylinders

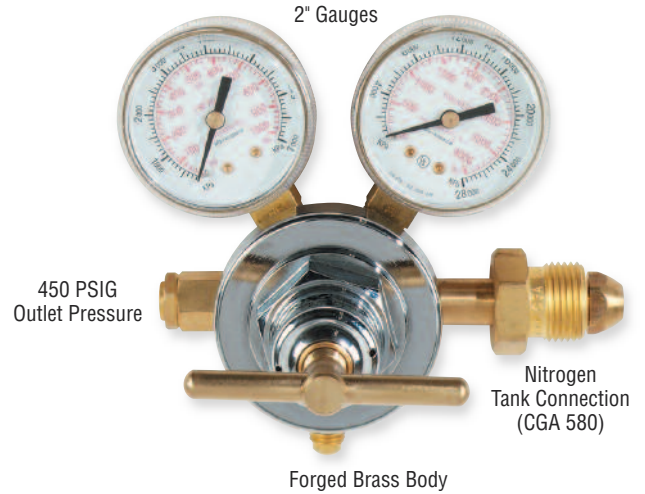

Forged Brass Body

## NITROGEN REGULATOR

PART NO.	OUTLET FITTING
EN-460F	1/4" Flare Male

A heavy duty regulator that delivers the pressure and volume most requested by professionals.

## NITROGEN CYLINDER STAND

Carry cylinders easily. These all steel stands are made for rugged use. Weighs only 4 lbs.

- **C-920 Stand**  
Holds 20 cu. ft. nitrogen cylinder.
- **C-940 Stand**  
Holds 40 cu. ft. nitrogen cylinder or 10 lb. CO<sub>2</sub> cylinder.
- **C-940CW**  
Same as C-940, but with wheels and handle.



C-940CW (shown)

## BLOW GUN

- OSHA Approved Nozzle
- Durable Construction
- ON/OFF Lever

BG-1 (shown)



## REFRIGERANT HOSE

- Nylon Lined/Low Porosity
- UL Approved
- Suitable for R12, R13A, R22, R500, R502, R410A and HCFC Blends
- 6 ft. Long

H72Y (shown)

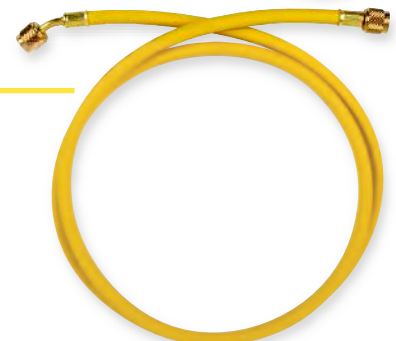

## CYLINDERS



**OXYGEN**  
**LO-20**  
 20 cu. ft.  
 Oxygen

**LO-40**  
 40 cu. ft.  
 Oxygen



**ACETYLENE**  
**LM-10**  
 MC-Acetylene  
 (10 cu. ft.)

**LB-40**  
 B-Acetylene  
 (40 cu. ft.)

## DISPOSABLE CYLINDERS



**QLP**  
**Propane Fuel**  
**Cylinder**

Net wt.: 14.1 oz.  
 (400 gm.)

Disposable steel cylinder. Fits most standard propane torches and other propane appliances.



**QLM**  
**MAP-Pro™**  
**Cylinder**

Net wt.: 16.0 oz.  
 (453.6 gm.)

Disposable steel cylinder containing a composition of Propylene.

*Cylinders meet DOT specifications.*

## ACCESSORIES



**MP-21**  
**Flame Shield**

Size: 10" x 18"

Asbestos free material helps protect walls, joints and studs from flame and spark damage.

**MP-22**  
**Leak Detector Fluid**  
 4 oz. Squeeze Bottle

Leak Detector – provides an easy and efficient method of leak detection.

- Safe for all gases and oxygen
- Non-flammable and non-corrosive
- Forms a readily visible and stable foam
- Flip top cap provides easy application



**MA-2**  
**Wrench**

Wrench for "B" and "MC" Acetylene cylinders.



**MA-4**  
**Wrench**

Multi-size wrench.



**MP-37-A**  
**Tip Cleaner**



**MP-35**  
**Welding Goggles**

Over-the-glasses style.



**MP-10**  
**Torch Stand**

Supports torch to eliminate relighting and prevents the hot tip from touching the work surface. Fits EX style extensions.



**MP-1**  
**Lighter**

Single flint lighter.  
 (Flint included.)



**MP-20XC**  
**Lighter**

MP-1 lighter with MP-2-5 flints packaged for display.



**MP-2-5**  
**Flints**

Holder of 5 flints for MP-1 lighter.



**MP-6**  
**Lighter**

Triple flint lighter.



**MP-7**  
**Flint**

Triple flint.

**KEY:** B Refers to 9/16 – 18 Threads  
A Refers to 3/8 – 24 Threads

LH Refers to Left Hand Threads  
RH Refers To Right Hand Threads

M Refers to Male Threads  
F Refers to Female Threads

Oxygen Has Right Hand Threads  
Fuel Gas Has Left Hand Threads

## PIG TAILS

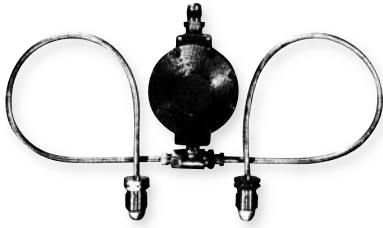

**IP-7** POL by Inverted Flare 20" long.  
**IP-8** POL by Inverted Flare 30" long.  
**EP-3-4B** 1/4" Flare Tee Block only.

## Y-OUTLET



**IP-3** 9/16" – 18 LH fittings.  
Connects to outlet of regulator.

## SURE GAUGES



**MP-39-MC** for MC cylinders.  
**MP-39-B** for B cylinders.  
**MP-39-O** for oxygen cylinders.  
Used to determine tank contents.

## COUPLERS & ADAPTERS

POL cylinder connection x 9/16" – 18 LHM hose fitting.

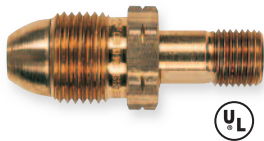

**IP-2 Adapter**  
Propane tank to hose.  
Includes built-in excess flow valve.

POL male to 2 POL females.

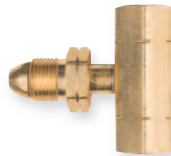

**6001 T-Coupler**  
Adapts POL cylinder to two POL regulators or manifolds.

1" - 20m THD x POL.

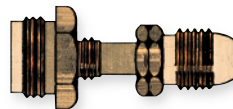

**BRS-913 Adapter**  
Adapts the EP-20 BR to POL fitting that is used on refillable cylinders.

1" 20m x 9/16" – 18 LHM hose fitting.

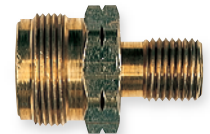

**BRS-461 Adapter**  
Enables hand torches that connect to disposable tanks to be connected to a hose.

## TIP TO HANDLE ADAPTERS

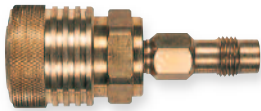

**BRS-770**  
Adapts snap-in tips to torch handles with screw-in design.



**BRS-665**  
Adapts the Goss variety of Pencil, Brush or Target® Tips to torch handles with snap-in design.



**BRS-986**  
Converts TW-5A and TW-10A oxy/fuel torch to snap-in air/fuel tips.



**BRS-700**  
Converts TW-5A and TW-10A oxy/fuel torch to screw-in air/fuel tips.

## TORCH OR REGULATOR TO HOSE

**BRS-339** (B) LHF to (A) LHM  
**BRS-340** (B) RHF to (A) RHM  
**BRS-341** (A) LHF to (B) LHM  
**BRS-342** (A) RHF to (B) RHM  
**BRS-707** (B) LHF to 1/4 NPT-F

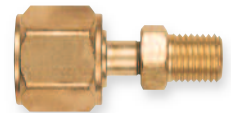

## HOSE TO HOSE

**BRS-314** "A" Fitting to "A" Fitting (Oxygen)  
**BRS-315** "A" Fitting to "B" Fitting (Fuel Gas)  
**BRS-316** "A" Fitting to "B" Fitting (Oxygen)  
**BRS-317** "A" Fitting to "A" Fitting (Fuel Gas)  
**BRS-318** "B" Fitting to "B" Fitting (Oxygen)  
**BRS-319** "B" Fitting to "B" Fitting (Fuel Gas)

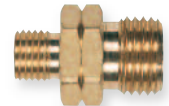

## QUICK CONNECT ADAPTER



**BRS-776**  
Snap Together



**BRS-776M**



**BRS-776F**

**BRS-776 Quick Change Adapter**

- High flow design
- Made of brass & aluminum
- UL Listed
- Connects torch to hose

## TORCH NUT

**No. 2303**  
Fits TCA-10 Cutting Attachment.



## CYLINDER TO REGULATOR ADAPTERS



**BRS-364**  
MC Cyl. to B Reg.



**BRS-363**  
POL Cyl. to Comm. Reg.



**BRS-362**  
Comm. Cyl. to POL Reg.



**BRS-365**  
B Cyl. to MC Reg.

## HANDLES / TORCHES

GOSS	TURBO	UNIWELD	DESCRIPTION
AA-1		TH-9	Handle acetylene, front valve for screw-in tips
AA-3	WA-400	TH-3	Handle acetylene, rear valve for screw-in tips
AP-1		TH-9B	Handle propane, front valve for screw-in tips
GG-4	G-4	TH-6	Handle for acet. snap-in tips rear valve, A fitting
GH-4	H-4	TH-6B	Handle propane, snap-in tips rear valve, B fitting
GP-6	TP-10		Propane only Economy torch
GP-9		PCV25	Torch soldering for disp. cyl.
GP-600	TX504	PZ-501	Self-igniting hand torch
GP-360D	STK-1		Torch Detail
GP-360L	STK-99	RP3T6	Torch Regular with igniter
GP-360R	STK-9	RP3T4	Torch Regular
GP-360SS	STK-11	RP3T5	Torch Super Size

## TIPS

GOSS	TURBO	UNIWELD	DESCRIPTION
BA-1	S-1	S-21	Tip acetylene, feather frame screw-in, x-fine
BA-2		S-22	Tip acetylene, feather frame screw-in, fine
BA-3	S-3	S-23	Tip acetylene, feather frame screw-in, medium
BA-4	S-4	S-24	Tip acetylene, feather frame screw-in, large
BA-5	S-5	S-25	Tip acetylene, feather frame screw-in, x-large
BA-6	S-6	S-26	Tip acetylene, feather frame screw-in, heavy duty
BA-9A		AS-3	Tip acetylene, target style screw-in, small
BA-10A		AS-8	Tip acetylene, target style screw-in, medium
BA-12A		AS-11	Tip acetylene, target style screw-in, large
BP-1		SM-36	Tip propane, pencil point screw-in, x-fine
BP-2		SM-38	Tip propane, pencil point screw-in, x-fine
BP-3			Tip propane, brush flame screw-in, medium
BP-4		ST06MP	Tip propane, brush flame screw-in, large
BP-5		ST07MP	Tip propane, brush flame screw-in, x-large
BP-6			Tip propane, brush flame screw-in, heavy duty
GA-2	A-2		Tip acet., snap-in, x-fine
GA-3	A-3	A-3	Tip acet., snap-in, fine
GA-5	A-5	A-5	Tip acet., snap-in, small
GA-8	A-8	A-8	Tip acet., snap-in, medium
GA-11	A-11	A-11	Tip acet., snap-in, large
GA-14	A-14		Tip acet., snap-in, x-large
GA-32	A-32		Tip acet., snap-in, heavy duty
GA-3L	PL-3A		Tip acet., Eze-Lite, snap-in, fine
GA-5L	PL-5A		Tip acet., snap-in, small
GA-8L	PL-8A		Tip acet., Eze-Lite, snap-in, med.
GA-14L	PL-12A		Tip acet., Eze-Lite, snap-in, med.
GT-2	T-2	T-2	Tip propane, snap-in, fine
GT-3	T-3	T-3	Tip propane, snap-in, fine
GT-4	T-4	T-4	Tip propane, snap-in, med.
GT-5	T-5	T-5	Tip propane, snap-in, large

## REGULATORS

GOSS	TURBO	UNIWELD	DESCRIPTION
EA-1G	AR-B	RB	Regulator B cyl., A outlet
EA-2G	AR-MC	RMC	Regulator MC cyl., A outlet
EP-20B	STK-R	RP-2B	Regulator propane/disposable cylinder
EP-70G	R-LP	RLPB	Propane regulator gauge
EP-80G			Propane regulator

## KITS

GOSS	TURBO	UNIWELD	DESCRIPTION
KA-1H			Kit for B acet., feather flame
KA-37H	WSF-4	K-41	Kit for B acet., screw-in tip
KA-38H	WSF-3	K-40	Kit for MC acet., screw-in tip
KLP-2	LP-2		Kit propane 2-target snap-in tips
KLP-4	LP-3	KLPTQ4	Kit propane 1-target snap-in tips
KP-102			Kit propane #2 pro flame screw-in tip
KP-105			Kit propane #5 pro flame screw-in tip
KP-320A*	Victor HS-101		Kit torch prop.heating with flow adapter
KP-320MA			Kit torch, auto ignition prop. heating, flow adapter
KX-3B	X-3B	89600	Kit acet. B #3, #11 snap-in tip
KX-4B	X-4B		Kit acet. B #5, #14 snap-in tip
KX-5B	X-5B		Kit acet. B #5 snap-in tip
KX-6MC	X-6MC		Kit acet. MC #3, #8 snap-in tips
KX-7B	X-7B		Kit acet. B #8 snap-in tip
KX-10B	PL-5ADLX-B		Kits, B acet., Eze-Lite, small
KX-10MC	PL-5ADLX-MC		Kits, MC acet., Eze-Lite, small
KX-15B	PL-8ADLX-B		Kits, B acet., Eze-Lite, med.
KX-15MC	PL-8ADLX-MC		Kits, MC acet., Eze-Lite, med.

## ADAPTERS

GOSS	TURBO	UNIWELD	DESCRIPTION
BRS-364	MCT	F-41	Cylinder adapter B to MC
BRS-365	BTMCR	F-31	Cylinder adapter MC to B
BRS-665		TUA	Adapter for snap-in torch
BRS-770	SA	UTA	Adapter for screw ftg. torch
IP-2			Flow adapter

## MISCELLANEOUS

GOSS	TURBO	UNIWELD	DESCRIPTION
C-800	TTMC	512	Stand for MC cylinder
C-850	TTB	502	Stand for B cylinder
DA-1		SS-38	Soldering iron, pyramid, acet.
DA-2		SS-37	Soldering iron, chisel, acet.
DA-8		LD-32	Leak detector, acetylene
HA3-12	AH-12	H-12	Hose acetylene, 12 ft. A conn.
HA3-25	AH-24	H-13	Hose acetylene, 25 ft. A conn.
HEF-12	H-12	HLP14B	Hose propane, 12 ft. B conn.
HEF-25	H-24	HLP-13B	Hose propane, 25 ft. B conn.
MA-2	TK	W05	Acetylene tank wrench
MP-1	L-1	FL-34	Striker, single round file
MP-2-5	F-1	FL-37	Flints for MP-1 striker
MP-37A	255-01P	TCSD	Tip cleaner set (12)

\*Western number cross reference WB-101

## GOSS TIP PERFORMANCE CHARTS

### CUTTING TIPS (ACETYLENE) 2341 Series

TIP SIZE	FUEL PSIG	OXYGEN PSIG	CUTTING THICKNESS
000	5	20	1/8"
00	5	25	1/4"
0	10	30	1/2"
1	10	35	3/4"
2	10	40	1-1/4"
3	10	45	2"

### BRAZING / WELDING TIPS (ACETYLENE) 3033, 2033 Series

TIP SIZE	FUEL PSIG	OXYGEN PSIG	BRAZING CAPACITY FOR COPPER TUBING	WELDING THICKNESS
00	5	5	1/8" - 3/4" (3 - 19 mm)	1/16" - 3/64"
0	5	5	1/4" - 1" (6 - 25 mm)	1/32" - 5/64"
1	7	7	1/4" - 1-1/4" (6 - 31 mm)	3/64" - 3/32"
2	7	7	1/2" - 1-1/2" (12 - 38 mm)	1/16" - 1/8"
3	7	10	3/4" - 1-1/2" (19 - 38 mm)	1/8" - 3/16"

### HEATING / SPECIALTY TIPS (ACETYLENE)

TIP STYLE	FUEL PSIG	OXYGEN PSIG	BRAZING CAPACITY FOR COPPER TUBING
2033H-15 Multiflame	10	20	up to 2-1/2"
2066T-00 Twin Tip	10	15	up to 1/2"
2066T-0 Twin Tip	10	15	up to 1"
2066T-1 Twin Tip	10	15	up to 2"
2077G-00 G-Tip	10	15	up to 1/2"
2077G-0 G-Tip	10	15	up to 1"
2077G-1 G-Tip	10	15	up to 1-1/2"
2077G-2 G-Tip	10	15	up to 2"
2077G-3 G-Tip	10	15	up to 2-1/2"
3033H-15 Multiflame	10	20	up to 2-1/2"
3033H-30 Multiflame*	10	20	up to 4"

\*Only use with 40 cu. ft. "B" cylinder.

## WARRANTY

### LIMITED WARRANTY:

Goss Inc. warrants to the original purchaser that its products shall be free from defects in material and workmanship under normal use and service within three (3) years of purchase. Goss Inc. will, at its election, repair, replace or make appropriate price adjustment where any product is found by inspection to be defective.

### LIMITATION OF LIABILITY:

It is understood and agreed that Goss Inc.'s liability, whether in contract, in tort, under any warranty in negligence or otherwise shall not exceed the return of the amount of the purchase price paid by the original purchaser and under no circumstances shall Goss Inc. be liable for special, indirect or consequential damages.

The price stated for the equipment is a consideration in limiting Goss Inc.'s liability. No action, regardless of form, arising out of the transactions under this Agreement may be brought by the purchaser more than one (1) year after the cause of action has accrued.

Some states do not allow limitations on how long an implied warranty lasts, or the exclusion or limitation of incidental or consequential damages, so this limitation and exclusion may not apply to you.

This warranty gives you specific legal rights, and you may also have other rights which vary from state to state.



Counter person and contractor friendly. All packaging and equipment are color-coded for easy identification.

 **PROFLAME (Air-Propane)**

 **NITROGEN EQUIPMENT**

 **TARGET TORCH & ACET-O-LITE (Air-Acetylene)**

 **GOSSWELD (Oxygen-Fuel)**

 **ACCESSORIES & GENERAL INFORMATION**

GOSS INC. • 1511 Route 8 • Glenshaw, PA 15116-2301 • USA  
Phone: 1-800-367-4677 • 1-412-486-6100 • Fax: 1-412-486-6844 • [www.gossonline.com](http://www.gossonline.com)