

Air Handling Unit eQ and eQ PLUS

Technical Data june 2010



FläktWoods

Contents

Introduction	9	refrigerant EQKN, EQKP.....	35
Unit configuration.....	12	Air cooler in hygienic design EQHN, EQHP.....	35
eQ Energy Solution	13	Empty section EQTB, EQTC.....	36
eQ Hygiene	15	Jointing frame EQVH.....	36
eQ Top	17	Silencer EQSA, EQSD.....	36
Flow chart.....	19	Recirculated air section.....	37
Unit configuration.....	20	Mixing section	37
Quick selection tables	21	Damper EQAZ-12.....	37
Design and characteristics	23	Humidifier EQQA, EQQB	38
Sizing.....	24	Cooling unit COOLER EQKA.....	39
Unit description		ReCooler EQKB	40
Casing	25	Combi Cooler EQKC	41
Frame	25	Twin Wheel system	42
Casing element in double-wall construction.....	25	Motors	
Intermediate floor in double deck casing.....	25	Asynchronous motors.....	43
Sealing strip.....	25	Integral motors.....	44
Classifications	26	DC motors	44
Outdoor design.....	26	Control equipment	
Official testing.....	26	ControlMaster.....	45
Hygienic design.....	26	Simplicity.....	45
Plenum fan, Centriflow Plus® EQLK.....	27	Coomunication	45
Centrifugal fan EQLR.....	28	Easy project design.....	45
Belt drive for centrifugal fan.....	28	Quick installation	45
Filter		High quality	45
Panel filter EQPA.....	29	Delivery options	46
Filter EQPB	29	ControlMaster	
Filter for eQ Top EQPT.....	29	Regulator	47
HEPA filter EQPF	30	Without control unit.....	47
Carbon filter EQPK.....	30	Location	47
Rotary heat exchanger		Quick connectors	47
REGOTERM®/TURBOTERM® EQRA	31	Lighting	47
Plate heat exchanger		Technical data	47
RECUTERM® EQRC.....	31	External fuse protection.....	47
Liquid-coupled heat exchangers		ControlMaster PLUS	
ECONET® EQRT.....	32	Climatix 600.....	48
ECOTERM® EQRF.....	33	Xenta 300.....	48
Air heater for hot water / frost coil		Without control unit.....	48
EQEE, EQEG, EQKE.....	33	Technical data	48
Air heater, electric EQEK, EQKK.....	33	Technical data	49
Air cooler, chilled water or evaporative		Testing	49
refrigerant EQNN, EQNP.....	34	Standards.....	49
Air cooler, chilled water or evaporative		Environmental requirements.....	49

Contents

Connection data.....	49	Mixing.....	57
Power consumption, plenum fan	50	Frequency converter	58
Power consumption, centrifugal fan.....	51	CAV and VAV systems.....	58
Standard functions	53	Test operation	58
Flow control	53	Technical benefits	58
Pressure control	53	Built-in frequency converter	58
CO ₂ control.....	53	Choice of frequency converter and motor	58
Adjusting the drive system.....	53	Dimensioning	59
Temperature control	53	Transformer	60
Supply air control	53	Full transformer.....	60
Extract air control	53	Communication.....	60
Room control.....	53	Base communication for ControlMaster.....	60
Seasonal temperature control	53	Primary protection	60
Other functions	54	Standards.....	60
Night purging	54	Enclosure	60
Cooling recovery	54	Protocols	61
Weather compensated temperature setpoint.....	54	BACnet.....	61
Night heating	54	LonWorks.....	61
Weather compensated flow /pressure setpoint ...	55	Modbus RTU.....	61
Outdoor temperature controlled fan speed.....	55	Web server with screens	61
External components	55	Fire protection functions.....	62
Controlling the air heater.....	55	Fire/smoke system, FICO-128	62
Control of air cooler.....	55	Multibox FCBA-2.....	62
Control of combined air heater /air cooler.....	55	Smoke detector	63
Circulation pump for air heater /cooler	55	Combustion gas unit, FCMA-2	63
Valve and valve actuator	55	Control unit for smoke detectors, ABAV 230	63
Damper actuator.....	55	Energy measurement	64
Alarm management	56	Extra temperature zones.....	64
Filter monitoring.....	56	Extra fans	64
Flow monitoring.....	56	Flow charts	65
Fire protection functions.....	56	Accessories Casing	
Frost protection.....	56	Inspection window EQAZ-01	81
Thermal overload protection	56	Lifting device EQAZ-02	81
Operation.....	56	Base frame EQAZ-04	82
Timer low speed	56	Adjustable feet (set) EQAZ-05.....	82
Timer high speed	56	Lifting tube, set EQAZ-06	83
Push button	56	Lifting spreader, set EQAZ-07	83
Presence detector	56	Bulkhead light EQAZ-09	83
Rotary heat exchanger.....	57	Armature connection EQAZ-10.....	83
Plate heat exchanger.....	57	Joining piece set EQAZ-16.....	83
Liquid-coupled heat exchanger	57	Anti-slip protection EQAZ-20.....	84
ECONET®	57	Espagnolette EQAZ-24	84

Contents

Flexible connection EQAZ-25	84	Inlet guard EQLZ-37	90
Duct connection piece EQAZ-26.....	84	Cable gland EQLZ-48.....	90
Counter-flange EQAZ-27	84	Accessories Humidifier	
Protective screen EQAZ-28	84	Humidifier replacement	90
Adjustment panels EQAZ-30	84	Accessories Control equipment	
Combination cover, for wall mounting		Cable trunk EQAZ-51, EQAZ-52	90
EQAZ-60.....	85	Accessories Liquid-coupled heat exchanger	
Combination cover, ceiling mounting		Heat exchanger package ECONET® EQRZ-05	91
EQAZ-61	85	Accessories Plate heat exchanger	
Ceiling lead-trough EQAZ-62.....	86	Washing tray, with drainage EQRZ-01	91
Stand for vertical position EQAZ-63	86	Accessories Plate heat exchanger and heating/cooling coil	
Extension legs with adjustable feet EQAZ-42	86	Water trap EQAZ-08	91
Bottom drain EQWZ-01	87	Accessories Heating/cooling coil	
Drain trough.....	87	Manual air purging valve	
Support beam EQAZ-11	87	with spigot EQAZ-18	92
Tool kit for eQ casing EQAZ-15	87	Automatic air purging valve	
Door stop EQAZ-17.....	87	with spigot EQAZ-19	92
Ground cable EQAZ-23	87	Expansion valve EQAZ-21	92
Floor grating EQAZ-29	87	Thermometer EQAZ-35.....	92
Accessories Damper		Flange, for air heater and air cooler EQAZ-40	93
Lever actuator EQAZ-13.....	87	Dagger plate EQTZ-05	93
Accessories Filter		Fin comb EQAZ-14.....	93
Analogue differential pressure gauge for measuring filter pressure drop EQPZ-12.....	88	Accessories Cooling unit, COOLER	
Differential pressure gauge type		Hot gas by pass EQKZ-01	93
Dwyer Magnehelic EQPZ-25	88	Accessories Outdoor design	
Filter mat for EQPA, set EQPZ-02.....	88	Roof EQBZ-01	94
Prefilter for EQPB, set EQPZ-05.....	88	Door stop for a door EQBZ-03.....	94
Replacement filter for EQPA set EQPZ-01.....	88	Hood, louvered shutter, flaps for outdoor unit EQBZ-09.....	94
Replacement filter for EQPB set EQPZ-03	88	Roof connection EQBZ-04	94
Replacement filter for EQPK, set EQPZ-06.....	88	Fan charts	
Filter cassettes for EQPF, set EQPZ-24	88	Plenum fan with EC-motor EQLK, EQLT - Description	95
Accessories Fan		EQLK-005-2	96
Outlet cowl, fan EQLZ-02	89	EQLK-008-2/009-2, EQLT-008-2	97
Screen protection EQLZ-24	89	EQLK-008-3/009-3, EQLT-008-3	98
Telpher beam EQLZ-25, Telpher EQLZ-29.....	89	EQLK-011-2/014-2, 1,7 kW.....	99
Manometer EQLZ-42	90	EQLK-011-2/014-2, EQLT-011-2, 3 kW.....	100
Air distributor EQLZ-13	90	EQLK-011-3/014-3/018-2/020-2, EQLT-011-3..	101
Inspection cover EQLZ-15	90	Plenum fan EQLK, EQLT - Description	102
Drain connection EQLZ-16.....	90	EQLK-005-2	103
Motor enclosures EQLZ-28	90		
Outlet guard EQLZ-36	90		

Contents

EQLK-008-2/009-2, EQLT-008-2	103	Air heater, electric, EQEK	129
EQLK-008-3/009-3, EQLT-008-3	103	Air cooler for chilled water EQNN	130
EQLK-011-2, EQLT-011-2	103	Air cooler for evaporative refrigerant EQNP	132
EQLK-011-3, EQLT-011-3	104	Air cooler in hygienic design EQHN	135
EQLK-014-2	104	Plenum fan EQLK	139
EQLK-014-3	104	Centrifugal fan EQLR	144
EQLK-018-2	104	Panel filter EQPA	147
EQLK-018-3/020-3	105	Filter EQPB	148
EQLK-020-2	105	HEPA filter EQPF	151
EQLK-023-2/027-2	105	Carbon filter EQPK	152
EQLK-023-3/027-3	105	Rotary heat exchanger EQRA	153
EQLK-032-2/036-2	106	Plate heat exchanger EQRC	154
EQLK-032-3/036-3/041-2	106	Humidifier EQQA	155
EQLK-041-3	106	COOLER EQKA	156
EQLK-045-2	106	ReCooler EQKB	157
EQLK-045-3/050-2/054-2	107	Combi Cooler EQKC	158
EQLK-050-3/054-3	107	ECOTERM® EQRF	159
EQLK-056-2	107	ECONET® EQRT	161
EQLK-056-3/068-2/072-3/079-2	107	Silencer EQSA	163
EQLK-063-2/072-2	108	Sound attenuator EQSD	164
EQLK-063-3/072-3	108	Empty section EQTB	165
EQLK-068-3	108	Empty section EQTC	166
EQLK-079-3/090-2	108	Air heater for hot water EQKE	170
EQLK-090-3	109	Air cooler EQKN, EQKP	171
Radial fan EQLR - Description	110	Casing end wall EQVA	172
EQLR-008-3/009-2	111	Connection frame full area EQVT	174
EQLR-009-3/011-2	112	Base frame EQAZ-04	175
EQLR-011-3/014-2	113	Damper EQAZ-12	176
EQLR-014-3/018-2/020-2	114	Flexible connection EQAZ-25	178
EQLR-018-3/020-3/023-2/027-2	115	Duct connection piece EQAZ-26	179
EQLR-023-3/027-3/032-2/036-2	116	Counter-flange EQAZ-27	180
EQLR-032-3/036-3/041-2/045-2	117	Protective screen EQAZ-28	181
EQLR-041-3/045-3/050-2/054-2/056-2	118	Roof EQBZ-01	182
EQLR-050-3/054-3/063-2/072-2/079-2	119	Louvred shutter EQBZ-09	183
EQLR-063-3/072-3/079-3/090-2	120	Outdoor adaption EQLZ-02	184
EQLR-090-3	121	Telpher beam EQAZ-25, Telpher EQLZ-29	185
Dimensions and weights		Product Code	
Unit casing EQGA, EQGB	122	How to read the product code	186
Unit casing EQHA, EQHB	123	Product code - Casing	
Air heater for hot water EQEE	124	Casing EQGA, EQGB	187
Electric air heater EQKK	127	Casing EQHA, EQHB	188
Frost coil EQEG	128	Factory installed unit in common base frame EQGM	189

Contents

Casing end wall EQVA	189	Radial fan EQLR	203
Connection full frame are EQVT.....	189	Belt drive for radial fan EQLR, EQLS	204
Jointing frame EQVH.....	190	Air distributor EQLZ-13	204
Mixing and extract air section EQVG	190	Draining EQLZ-15, EQLZ-16	204
Product code - Filter		Telpher beam EQLZ-25.....	204
Panel filter EQPA.....	191	Motor enclosures EQLZ-28	204
Replacement filter EQPZ-01.....	191	Telpher EQLZ-29	205
Filter mat for EQPA, EQPZ-02	191	Protective screen door EQLZ-24	205
HEPA filter EQPF	192	Analogue flow indicator for fan EQLZ-42	205
Filter cassettes for HEPA filter EQPZ-24.....	192	Differential thermostat EQRZ-03	205
Carbon filter EQPK.....	192	Spacer beam EQRZ-04	205
Replacement filters EQPZ-06	192	Plenum fan, Centriflow Plus® EQLK.....	206
Filter EQPB	193	Outlet guard EQLZ-36	207
Replacement filter EQPZ-03.....	194	Contact protection inlet EQLZ-37	207
Prefilter for EQPB, EQPZ-05.....	194	Cable gland EQLZ-48.....	207
Filter for eQ Top EQPT	194	Fan function for eQ Top	207
Replacement filters EQPZ-04	194	Product code - Silencer, Empty section	
Analogue differential pressure sensor EQPZ-12... 194		Silencer EQSA	208
Differential pressure sensor EQPZ-25.....	194	Empty section EQTC	208
Product code - Air heater		Product code - Heat exchanger	
Air heater for hot water EQEE.....	195	Rotary heat exchanger REGOTERM® EQRA.....	209
Frost coil EQEG.....	195	Rotary heat exchanger REGOTERM® EQRB.....	209
Air heater, electric EQEK	196	Plate heat exchanger, RECUTERM® EQRC	210
Heating coil EQEO	197	Drain tray EQRZ-01.....	210
Gas-fired heater for natural gas EQEB	197	Liquid-coupled heat exchanger ECOTERM® EQRF..	211
Air heater for steam EQES	197	Liquid-coupled heat exchanger ECONET® EQRT .	212
Product code - Air cooler		Heat exchanger package for ECONET® EQRZ-05..	212
Air cooler for chilled water EQNN	198	Product code - Components mounted in duct	
Air cooler for evaporative refrigerant EQNP	198	Air heater for hot water, mounted in duct EQKE... 213	
Reinforced insulation drain trough EQKZ-01....	199	Air heater, water EQDE	213
Air cooler for chilled water, hygiene EQHN	199	Electric air heater, mounted in ductwork EQKK ... 213	
Air cooler for cooling water, hygiene EQHP	199	Air cooler for chilled water, mounted in duct EQKN .. 213	
COOLER® EQKA	200	Air cooler, water EQDN.....	214
Hot gas by pass EQKZ-01	200	Air cooler , DX , mount. in duct EQKP	214
ReCooler EQKB	201	Silencer, mounted in duct EQSD	214
Combi Cooler EQKC	201	Product code - Accessories	
Humidifier, evaporative EQQA	202	Inspection window EQAZ-01	215
Humidifier, steam lances EQQB.....	202	Lifting device EQAZ-02	215
Humidifier fill EQQZ-01.....	202	Base frame EQAZ-03	215
Empty section adjacent to cooling coil EQTB	202	Base frame EQAZ-04.....	215
Dagger plate EQTZ-05	202	Adjustable feet (set) EQAZ-05.....	215
Frost protection screen EQTE.....	202	Lifting tube, set EQAZ-06	215
Product code - Fans		Lifting spreader, set EQAZ-07	215
		Water trap EQAZ-08	215

Contents

Bulkhead light EQAZ-09	216	Two-speed motor, 4/6 poles, with separate windings, highest output for both speeds	
Bulkhead light connection EQAZ-10	216	ATSL	223
Tool kit for eQ casing EQAZ-15	216	Two-speed, 2/4, 4/8 poles,	
Damper EQAZ-12.....	216	Dahlander-winding ARAL	223
Lever actuator EQAZ-13.....	217	Two-speed, 2/4, 4/8 poles, separate windings,	
Fin comb EQAZ-14	217	highest output for both speeds ARSL.....	223
Doorstop (for doors on pressurized units) EQAZ-17....	217	Two-speed, 2/4, 4/8 poles,	
Manual air purging valve EQAZ-18.....	217	with separate stator windings ASSL	223
Automatic air purging valve EQAZ-19.....	217	Product code - Control equipment	
Anti-slip protection EQAZ-20.....	217	Cable ducting, horizontal EQAZ-53.....	224
Expansion valve EQAZ-21	217	Electrical equipment cubicle section EQEL	224
Shrink-film packing EQAZ-22	218	Empty section for controls EQTK	225
Earth cable EQAZ-23.....	218	Control equipment STEQ	225
Espagnolette EQAZ-24	218	Temperature control STAZ-01	226
Flexible connection EQAZ-25	219	Temperature sensor STAZ-02	226
Duct connection piece EQAZ-26.....	219	Preheater (Frostcoil) STAZ-08.....	227
Counter-flange (d = 2,4) EQAZ-27	219	Zone control STAZ-09.....	227
Protective screen EQAZ-28	219	Defrosting STAZ-10	228
Floor grating EQAZ-29	219	Anti-freeze sensor STAZ-11	228
Adjustment panels EQAZ-30	219	Starting equipment pump	
Thermometer EQAZ-35.....	219	(for circulation pump) STAZ-15	228
Installation instructions EQAZ-36.....	219	Valve / valve actuator STAZ-16.....	229
Additional packaging EQAZ-39.....	219	Pipework package STAZ-17.....	229
Flange for air heater coil, air cooler coil EQAZ-40	220	Fan control STAZ-20	230
Extension leg with adjustable feet EQAZ-42.....	220	Starting equipment-fan STAZ-21	230
Combination cover, wall mounting EQAZ-60... ..	220	Pressure / flow indicator STAZ-22.....	231
Combination cover, ceiling mounting EQAZ-61	220	Flow monitor STAZ-23	231
Ceiling lead-trough EQAZ-62.....	220	Filter monitor STAZ-24.....	231
Stand for vertical positioning EQAZ-63	220	Control of external fan STAZ-25	232
Roof EQBZ-01	221	Damper actuator STAZ-30	233
Door stop for a door EQBZ-03.....	221	Damper actuator, additional zone STAZ-31	233
Roof connection EQBZ-04	221	Control documentation STAZ-36.....	234
Cover, louvered shutter, flaps for outdoor unit EQBZ-09.....	221	Fire function STAZ-40.....	234
Cowl for inlet and outlet in end wall EQBZ-10... ..	222	Extra transformer for fire equipm. STAZ-41	234
Cowl for inlet and outlet in side wall EQBZ-11 ..	222	Smoke detectors STAZ-42	235
Bottom drain EQWZ-01	222	Smoke damper function STAZ-43	235
Drain trough EQWZ-02	222	Fire thermostat STAZ-44	235
Product code - Motors		Prolonged /boosted operation STAZ-50.....	235
Single-speed motor APAL.....	223	Communication STAZ-51	235
Integral motor APAT	223	Multipole cable STAZ-70.....	236
Motor, EC.....	223	Control unit Twin Wheel STAZ-72.....	236
Two-speed motor, 4/6 poles,		ECONET® Pump unit STAZ-74	237
with separate stator windings ATAL.....	223	Externally auxiliary functions STAZ-75	237

Contents

Switch disconnecter STAZ-80.....	238
Energy measurement STAZ-81.....	238
Transformer STAZ-82.....	238
Extra fuse STAZ-83.....	238
Lighting/ power socket in electrical cabinet STAZ-84.....	238
Frequency inverter STRR.....	239
Motor accessories APAC.....	239
Product code - Certificates	
Air handling unit CERZ-01.....	240
Fans CERZ-02.....	240
Heat exchangers CERZ-03.....	240
Materials CERZ-04.....	240
Weight CERZ-05.....	240
Air handling unit (Russia) CERZ-06.....	240
Of origin CERZ-07.....	240
Inspection CERZ-08.....	240
Tightness CERZ-09.....	240

eQ HIGHLIGHTS

- ENERGY EFFICIENT
- HIGH PERFORMANCE
- HYGIENIC DESIGN
- INTEGRATED CONTROLS
- MODULARITY/
COMMON CROSS SECTIONS
- CORROSION CLASS C4
- SERVICE FRIENDLY
- FAST COMMISSIONING
- SHORT DELIVERY TIMES



eQ is our new, highly adaptable air handling unit offering a number of new features that have not previously been available on the market. The intelligent casing design, the energy-efficient components and the flexible design mean that eQ is cost-effective, and the possibility of both a single casing and a double casing unit makes it highly flexible.

eQ is based on long experience of air handling. Fläkt Woods has been developing and producing air handling units for more than 100 years, and the majority of eQ's main components, such as fans, recovery units,

dampers and silencers are manufactured by Fläkt Woods. The components have been selected to be as energy saving as possible.

The modern air handling unit is designed to meet all conceivable air handling requirements and standards in Europe. eQ meets the requirements according to the classification in the CEN standard for air handling units and is manufactured in a certified workshop with regard both to quality (ISO 9001) and to the environment (ISO 14001).

eQ is certified by EUROVENT.



Introduction

eQ consists of two ranges, eQ and eQ PLUS, that cover 21 sizes, which covers an air flow range from 0.1 m³/s to 12.5 m³/s. Everything from single supply air or exhaust air units to complete units with heat recovery, energy-efficient components and built-in control and regulation systems is available. The length of the unit is determined by the selected components.

The unit is very simple to select, install and commission.

Typical installations

The wide range means that eQ is available for every area; whether inside a unit room or on the roof. eQ is suitable for installations for industrial premises and public buildings as well as dwellings, schools, offices, shops and hospitals.



eQ and eQ PLUS

eQ is divided into two lines - eQ and eQ PLUS. The eQ line covers the most common functions and is standardized, enabling shorter delivery times. The eQ PLUS line is customized and covers functions for applications with special demands. It is possible to combine the two lines, with only one or a few eQ PLUS functions. Energy efficiency, high performance and fast commissioning are some of the qualities applied on both eQ lines.



Introduction

eQ - standardised



Standardized

Shorter delivery times and the possibility for us to offer the most competitive price are two important factors that are gained from the standardized eQ line. The components are on stock, enabling a quick delivery.

Optimized

For the eQ line we have chosen the nine most common sizes with all functions available, such as built-in COOLER, rotary heat exchanger etc. All functions are well tested and optimized. The eQ unit can be delivered as a single deck or double deck unit, or as a combination.

Flexible

The eQ is a unique unit with the possibility to achieve short installations for narrow spaces. For extreme narrow installations, sizes 008 and 011 can be delivered as eQ Top, with all connections faced upwards.

Smart standard controls

Standard control platform with modular structure for high level of flexibility. The cabling design is made for easy and fast installation at site. Enhanced HMI for easy commissioning and operation. Communication is standard.

Energy efficient

Energy efficiency is one of the main drivers of Fläkt Woods' vision. The majority of eQ's main components, such as fans, recovery units, dampers and silencers are manufactured in-house and designed to be as energy saving as possible.

eQ PLUS - customer adapted



Customer adapted

For installations with higher demands on hygiene or material for example, there is the eQ PLUS line in which the air handling unit, or parts of it, can be customer adapted. The eQ PLUS line offers a wider range of components than the eQ line, increasing the functionality and flexibility. As these components are not stocked the delivery time will be longer.

Special demands

For installations that demand functionality above the eQ line, the solution is most likely available in the eQ PLUS line. For instance, the installation might require a humidifier in order to achieve a specific humidity level. The application environment might also require components in a specific material, such as casing in stainless steel, Cu-Cu coils etc.

Increased flexibility

The possibility to combine single and double deck units has been increased in combinations and sizes in the eQ PLUS line.

Installations with high demands might need one or a few functions outside the eQ line. The eQ and eQ PLUS lines can therefore be combined. The unit platform could be standardized, whereas a selection of the functions are customized. This possibility makes the eQ PLUS one of the most flexible lines on the market.

Customer adapted control

Customer adapted controls solutions for every possible application.

Energy solutions

All of the energy efficient components in the eQ line are also available in the eQ PLUS line. On top of that Fläkt Woods also offers a number of world class solutions for energy efficiency, such as the ReCooler, Combi Cooler and the Twin Wheel system.

Unit configuration

The eQ unit is available in several configurations, either as a modular unit in a single deck casing or as a compact unit in a double deck casing or as a combination between the two. For narrow installations, size 008 and 011 are available as eQ Top, with all connections placed upwards. The following are examples of configurations:



Supply air or exhaust air unit, modular design.

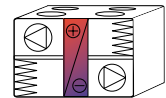

eQ Top with all connections placed upwards, available for sizes 008 and 011. Supply air and exhaust air unit with rotary heat exchanger.

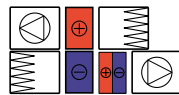

Supply air and exhaust air unit with liquid-coupled heat exchanger.

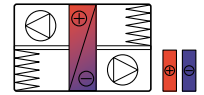

Supply air and exhaust air unit with rotary, plate or liquid-coupled heat exchanger, compact design. Cooling coils and heating coils are supplied separately and are installed in the duct.

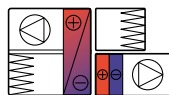

Supply air and exhaust air, unit with rotary or plate heat exchanger. Combination of compact and modular design.

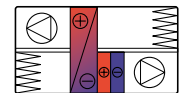

Supply air and exhaust air unit with rotary or plate heat exchanger. All components built in, such as fans, filters, dampers, heat exchanger, cooling and heating coils.

eQ Energy Solutions

To achieve an energy-efficient climate control system, the components must be carefully chosen to optimise the system's overall performance.

Normally, the most energy-intensive function in a climate system is the air handling unit. Energy is required both to control the airflow in and out of the building, and to condition the supply air.



The energy required to produce an airflow depends partly on the pressure increase the fan must achieve to prevent a pressure drop in the airflow components, and partly on the drive equipment's efficiency ratings. Energy consumption can be reduced by minimising pressure drop in the airflow components, and by ensuring that the fan, motor and control equipment are high efficient. A measure of an air handling unit's energy consumption when regulating the supply and extract airflow is the unit's SFP_v value, defined as follows:

$$SFP_v = \frac{P_{\text{mains SF}} + P_{\text{mains EF}}}{q_{\text{max}}}$$

- SFP_v = the specific fan power required by the air handling unit, kW/(m³/s)
 $P_{\text{mains SF}}$ = the fan power of the supply air fan, kW
 $P_{\text{mains EF}}$ = the fan power of the extract air fan, kW
 q_{max} = the unit's highest flow, supply or exhaust air flow, m³/s

P_{mains} is defined as the active electrical power supplied by the mains with an air density of 1.2 kg/m³, clean filters and dry heat exchangers.



Save energy, economy and environment with Fläkt Woods

Energy optimization is an important aspect of ventilation, where Fläkt Woods have acclaimed expertise.

We use e³ to highlight products and solutions that are particularly effective. They serve a dual purpose of saving both your long-term economy and our environment.

www.flaktwoods.com/energy



The energy required to condition the supply air to a building largely depends on how the energy in the extract air can be recovered. A high recovery degree reduces the energy requirement. However, an increased pressure drop over the heat regenerator raises the fan's energy consumption. For this reason, the regenerator must be optimised with regard to both recovery degree and pressure drop.

An optimally dimensioned climate system offers significant energy savings. These savings normally result in a very short payback time for the investment, while also significantly reducing the climate system's environmental impact.

Fläkt Woods has spent many years developing products that take into account important factors such as:

- Efficiency
- Environmental impact
- Reliability
- Freezing
- Cooling recovery
- Pressure drop
- Leakage
- Control
- Humidity transfer
- Odour transfer

eQ - when hygiene is especially crucial



In order for operations to run smoothly, certain working environments require a hygienic indoor climate that is guaranteed to be bacteriafree. Fläkt Woods has long experience of hygiene applications. Over 300 hospitals in 18 countries in Europe and Asia use Fläkt Woods ventilation systems.

With the new eQ air handling unit, we offer safe, high-quality solutions for a hygienic indoor climate.



**Institut für
geprüft
RLT-Hygiene
2007-2010
Lufthygiene**

Hygienerrelevante Merkmale

- VDI 6022 (D)
- VDI 3803 (D)
- ÖNORM H 6021 (A)
- SWKI VA104-01 (CH)
- DIN EN 13779 (EU)
- DIN 1946 Teil 4 (D)
- SWKI 99-3 (CH)
- ÖNORM H 6020-1 (A)

geprüft durch **ILH BERLIN**

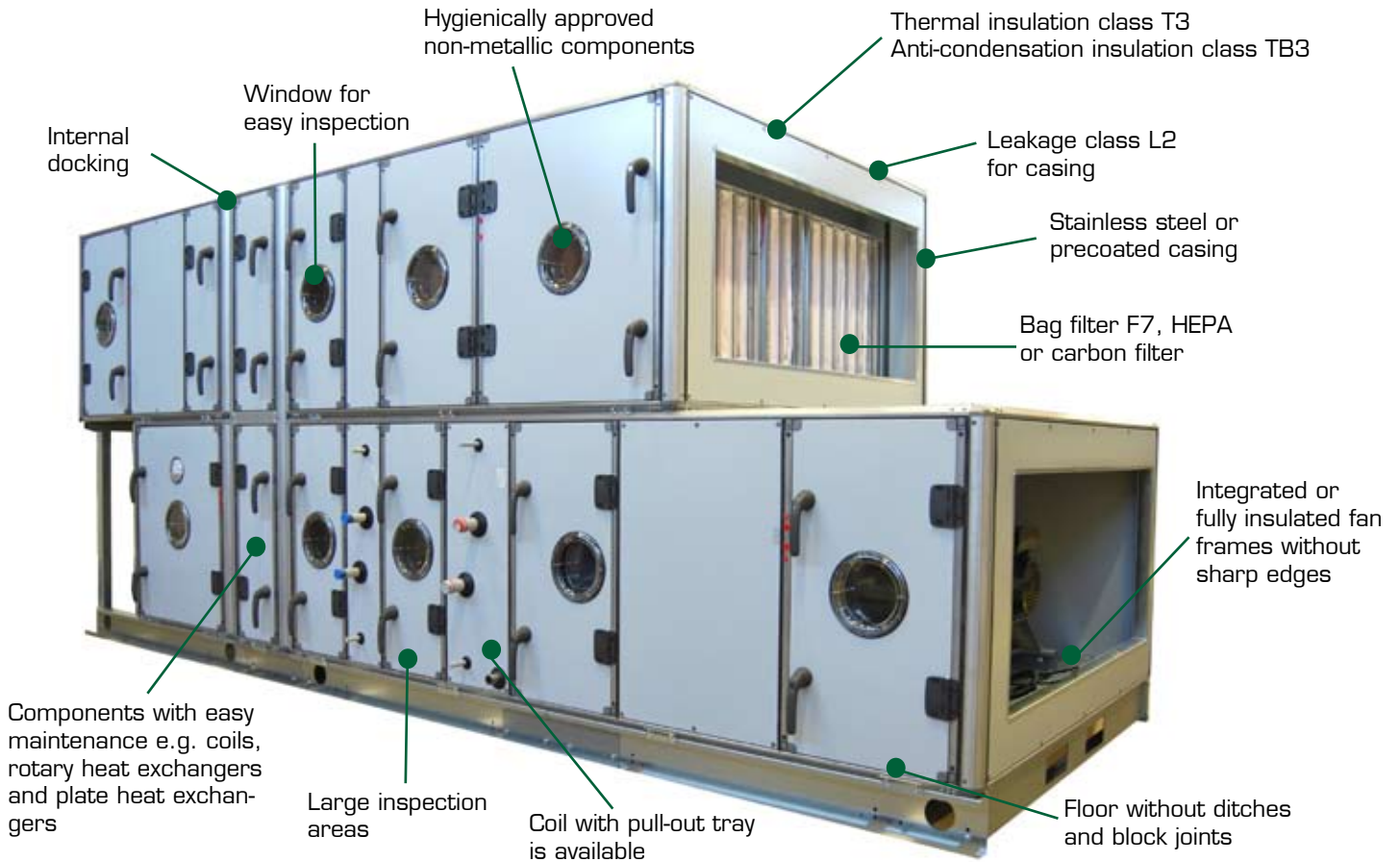

Easy configuration with product selection tool ACON

To ensure correct configuration of hygiene units, ACON has a Hygiene Verification Check function that helps the user to configure a unit compliant with VDI 6022 for standard hygiene or EN 1946-4 for hospital environments. ACON provides clear recommendations and instructions to ensure that the unit meets relevant standards.

Fläkt Woods recommends that the user has good prior experience of hygiene projects, as certain standard requirements must be met by the electrical technician and the customer.

ACON provides all the information and support required for good planning

- Product size
- Audio data
- Efficiency
- LCC
- Delivery time
- DXF and DWG files can be exported to CAD software
- Support available for Autodesk i-drop
- Relevant documentation always supplied

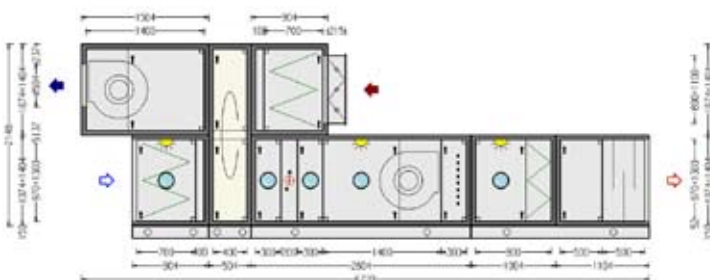



eQ Top

The eQ Top is a compact configuration, manufactured in two sizes with an air flow range of 0.2 - 1.6 m³/s. Since all connections are placed upwards, the eQ Top is suitable for narrow installations.

The eQ Top is supplied with direct-driven supply and extract air fans, supply and extract air filters and a rotary heat exchanger. There is a wide range of accessories for the eQ Top for in-duct air processing, such as dampers, coils, silencers etc. The control system, which is integrated with the unit, is ready for use with a large number of external functions. Temperature sensors and actuators can be easily connected using quick connectors.

Fan

The eQ Top is equipped with plenum fans Centriflow PLUS®.

The fans are driven by high efficient motors which means that the air handling unit is very energy efficient.

The fans' integral or EC motors have infinitely variable control.

Fan motors available for the eQ Top

- Integral motor
- EC motor
- Standard motor without frequency converter

Typical installations

The eQ Top is suitable for installation in public buildings such as child care centres, schools, offices, shops etc. The eQ Top is intended for indoor installation.

Filter

Supply and extract air filters made of fibreglass.

Filter class F7 (EU7).

All filters in the eQ Top are of the ultra compact type which are easy to pull out when they are being replaced.

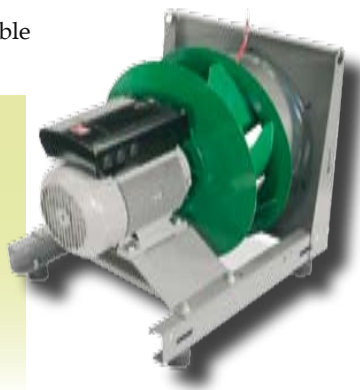



Connections

All connections are placed upwards, which makes eQ Top suitable for installations with minimum space. The connections are round with rubber rings.

It is possible to connect external functional components such as coils, silencers etc., directly onto the air handling unit whereas cooling coils, for example, needs to be placed horizontally in the duct system.

Easy dismantle for transportation indoors

To make it easy to transport through narrow doorways the eQ Top can be ordered as a version that can be dismantled. The unit parts are delivered on one base frame. The three sections can easily be separated using external joints. If the unit needs to be dismantled there are quick connections between the unit sections in order to simplify the separation of blocks.

The most common external components are delivered with quick connections for easy connection to the cabinet.

Operation

The eQ Top is supplied with a control unit as standard and this includes a control panel for operation. All functions are displayed in plain text.

All settings are made and readings taken using the control panel.

Delivery configuration

The units can be supplied with customized fan arrangement. The standard configuration is a top or bottom right-hand supply air fan. The unit can be changed with ease to a configuration with a top or bottom left-hand supply air fan. This is done by means of a simple switching operation in the control system.

Available configurations

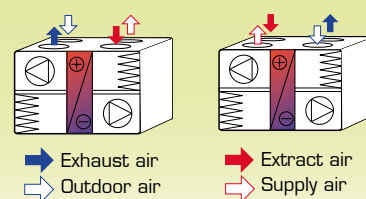

Flow chart

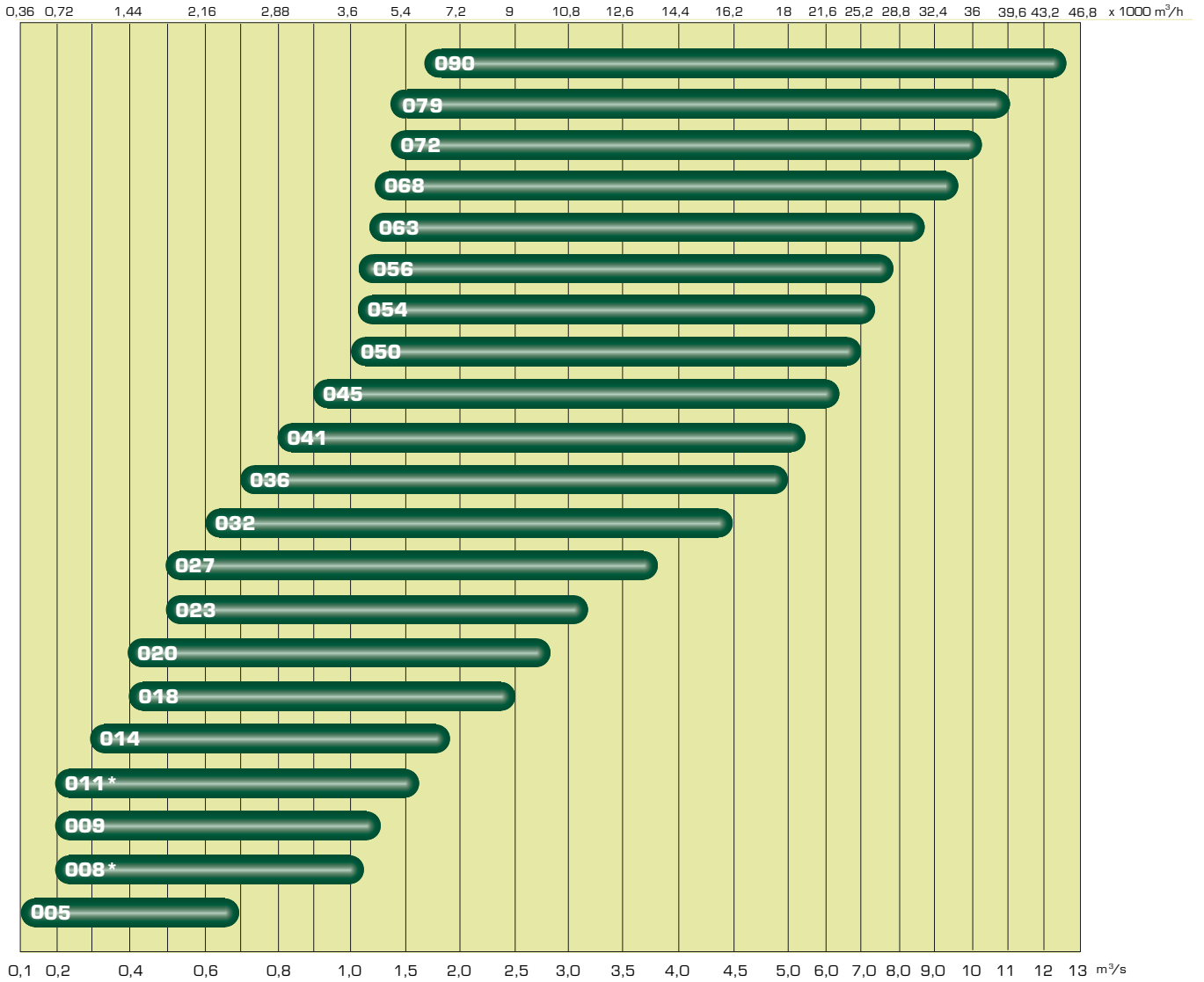

* Available as eQ Top, with all connections faced upwards.



Unit configuration

Accessible functional parts, depending on unit size

Unit size	Rotary heat exchanger REGOTERM®, TURBOTERM®	Plate heat exchanger RECUTERM®	Liquid-coupled heat exchanger ECOTERM®	Liquid-coupled heat exchanger ECONET®	COOLER ReCooler with cooling recovery**	Built-in heating/cooling coils	Duct-mounted heating / cooling coils	Humidifier **	Combi Cooler **
005	•	•	•			•	•	eQ PLUS	
008*	•	•	•	•	•	•	•	eQ PLUS	
009	eQ PLUS	eQ PLUS	•	•	•	•	•	eQ PLUS	
011*	•	•	•	•	•	•	•	eQ PLUS	
014	eQ PLUS	eQ PLUS	•	•		•		eQ PLUS	eQ PLUS
018	•	•	•	•	•	•	•	eQ PLUS	eQ PLUS
020	eQ PLUS	eQ PLUS	•	•		•		eQ PLUS	
023	•	•	•	•	•	•	•	eQ PLUS	eQ PLUS
027	eQ PLUS	eQ PLUS	•	•		•		eQ PLUS	
032	•	•	•	•	•	•	•	eQ PLUS	eQ PLUS
036	eQ PLUS	eQ PLUS	•	•		•		eQ PLUS	
041	•	•	•	•	•	•	•	eQ PLUS	eQ PLUS
045	eQ PLUS	eQ PLUS	•	•		•		eQ PLUS	
050	•	•	•	•	•	•	•	eQ PLUS	
054	eQ PLUS	eQ PLUS	•	•		•		eQ PLUS	
056	eQ PLUS		•	•		•		eQ PLUS	
063	eQ PLUS	eQ PLUS	•	•		•		eQ PLUS	
068	eQ PLUS		•	•		•		eQ PLUS	
072	•	•	•	•	•	•	•	eQ PLUS	
079	eQ PLUS		•	•		•		eQ PLUS	
090	eQ PLUS		•	•		•		eQ PLUS	

* Available as eQ Top.

** Functions in the eQ PLUS line.

Filters and fans are available for all sizes.

Quick selection tables



A three digit code describes the sizes in the eQ range and they indicate the airflow rate at a filter face velocity of 2.5 m/s.

	Air flow m ³ /s (m ³ /h)				Filter		Ext. cross-section		
	Max (3,5 m/s over filter)	Air cooler (buildt in cooling unit) face velocity, m/s			Filter cassettes	Cassettes	Unit width, mm	Unit height, mm single deck	Unit height, mm two deck
		2,0 m/s	2,5 m/s	3,0 m/s					
005	0,7 (2520)	0,4 (1400)	0,5 (1800)	0,6 (2160)	300x600		800	476	952
008*	1,1 (4032)	0,7 (2520)	0,9 (3240)	1,1 (3960)	800x400		1100	576	1152
009	1,3 (4680)	0,7 (2520)	0,8 (2880)	1,0 (3600)	600x600		800	776	1552
011*	1,6 (5760)	1,0 (3600)	1,3 (4680)	1,5 (5400)	2x500x500		1200	676	1352
014	1,9 (6840)	1,0 (3600)	1,3 (4680)	1,6 (5760)	600x600 300x600		1100	776	1552
018	2,5 (9000)	1,4 (5040)	1,8 (6480)	2,1 (7560)	2x600x600		1400	776	1552
020	2,8 (10080)	1,5 (5400)	1,9 (6840)	2,3 (8280)	600x600 2x300x600 300x300		1100	1076	2152
023	3,3 (11808)	2,2 (7920)	2,7 (9720)	3,3 (11880)	2x600x600 300x600		1700	926	1852
027	3,8 (13680)	2,1 (7560)	2,6 (9360)	3,1 (11160)	2x600x600 2x300x600		1400	1076	2152
032	4,5 (16200)	2,6 (9360)	3,3 (11880)	4,0 (14400)	4x400x800		1800	1026	2052
036	5,0 (18000)	2,6 (9360)	3,3 (11880)	4,0 (14400)	4x600x600		1400	1376	-
041	5,7 (20520)	3,2 (11500)	4,0 (14400)	4,8 (17280)	3x600x600 3x300x600		2000	1076	2152
045	6,3 (22680)	3,4 (12240)	4,2 (15120)	5,0 (18000)	4x600x600 2x300x600		1700	1376	-

* Available as eQ Top.

Quick selection tables

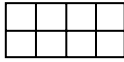
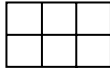
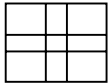
A three digit code describes the sizes in the eQ range and they indicate the airflow rate at a filter face velocity of 2.5 m/s.

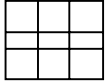
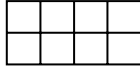
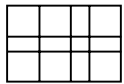
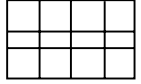
	Air flow m ³ /s (m ³ /h)				Filter		Ext. cross-section		
	Max (3,5 m/s over filter)	Air cooler (buildt in cooling unit) face velocity, m/s			Filter cassettes	Cassettes	Unit width, mm	Unit height, mm single deck	Unit height, mm two deck
		2,0 m/s	2,5 m/s	3,0 m/s					
050	7,0 (25200)	4,3 (15480)	5,3 (19080)	6,4 (23040)	8x500x500		2300	1226	2452
054	7,3 (26280)	4,1 (14760)	5,1 (18360)	6,1 (21960)	6x600x600		2000	1376	-
056	7,9 (28350)	4,3 (15470)	5,4 (19340)	6,4 (23210)	4x600x600 4x300x600 300x300		1700	1676	-
063	8,8 (31750)	4,8 (17280)	6,0 (21600)	7,2 (25920)	6x600x600 2x300x600		2300	1376	-
068	9,5 (34020)	5,2 (18790)	6,5 (23490)	7,8 (28180)	6x600x600 3x300x600		2000	1676	-
072	10,1 (36290)	5,5 (19800)	6,9 (24840)	8,3 (29880)	8x600x600		2600	1376	-
079	11,0 (39600)	6,1 (22100)	7,7 (27630)	9,2 (33160)	6x600x600 5*300*600 1x300x300		2300	1676	-
090	12,6 (45360)	7,1 (25420)	8,8 (31770)	10,6 (38130)	8x600x600 4x300x600		2600	1676	-

Design and characteristics



A unit for high demands for air handling

Air handling unit eQ meets the requirements according to the classification in the CEN standard for air handling units. The component parts making up the unit are designed and tested in accordance with international norms. The eQ air handling unit is manufactured in 21 sizes, which cover an air flow range from 0.1 to 12.5 m³/s (360 m³/h to 45 000 m³/h). It is supplied in blocks, which include one or more

functions, or as a complete pre-assembled unit. The unit is available for both indoor and outdoor installation with air handling combinations for different heat recovery alternatives. The unit is manufactured by Flakt Woods, which has a certified management system according to ISO 9001 (quality), ISO 14001 (external environment) and AFS 2001:1 (working environment).

What gives the unit its quality:

- The construction of the unit casing meets the requirements of the CEN standard for air handling units.
- In-house manufacture means that the functions are optimally adapted to the eQ unit.
- A robust frame with fully closed frame profiles gives a unit casing with high strength.
- Casing elements in double-wall construction with a 50 mm thick sandwich layer of non-combustible mineral wool insulation providing good thermal and acoustic insulation.
- Mechanically secured sealing strips of cellular rubber in the inspection doors reduce leakage flow to a minimum.
- Can be supplied in blocks with one or more functional parts to facilitate transport and installation in tight spaces.
- Totally smooth inside and outside, which ensures that strict hygiene requirements are met.
- Free choice of material and surface finish for the unit casing.
 - Casing element and frame made of aluminium zinc coated sheet steel or stainless sheet steel.
 - Casing element with internal and external polyester-coated, galvanized sheet steel and aluminium zinc coated frame.
 - Mineral wool, standard and heavy.

Sizing



Unit sizing via the Web

Airhandlingconfiguration - ACON is the name of the new generation of web-based product selection programs. With ACON, eQ can be sized quickly and easily. The program offers an air handling unit specification and all the facts needed, such as dimensions, efficiencies, acoustic levels, etc.

The program also provides product specific documentation concerning installation, mounting and maintenance. ACON enables calculations for LCC (Life Cycle Costs), energy consumption and operation costs.

- Always the latest version of the soft ware.
- Requires no installation.
- Always available on the Internet.
- Fan performance curves with duty points, etc.
- The unit drawing can be exported to CAD.
- Calculates energy consumption and CO2 emissions.
- Calculates the units LCC (Life Cycle Costs).
- Easy to combine eQ and eQ PLUS.

To enable you to access to the program, you need a user ID and a password.

You can obtain these by contacting our nearest sales representative.

To find the nearest sales representative, visit our web site at www.flaktwoods.com.

Unit description

Casing

The unit casing consists of closed frame profiles made of aluminium zinc coated sheet steel, which are joined together with strong corner pieces. Taken all together, this forms a strong and stable frame.

The casing elements and inspection doors are executed as a double plate construction with a 50 mm sandwich layer of mineral wool insulation.

The inspection doors are mounted on adjustable hinges in all unit sizes and are equipped with mechanically secured sealing strips.

The inspection doors can also be obtained with door locks. The double-wall construction of the casing gives the unit a smooth inside and outside, which facilitates cleaning and reduces the risk of accumulations of dirt. The fact that the inside of the unit is fully covered with sheet metal eliminates the risk of fibres being carried along by the air flow.

To facilitate maintenance and service, the casing for many functional parts can be supplied with inspection windows.

The unit casing is designed for:

- 2500 Pa negative or positive pressure
- max 70°C air temperature
- min -30°C air temperature



Design, eQ PLUS:

- insulation equivalent fire ratings EI15 resp. EI30
- hygienic design for indoor and outdoor applications.



Frame

The frame is manufactured from closed profiles using 1.5 mm galvanized sheet steel or aluminium zinc coated sheet steel. Joining of blocks is done using internal or external screwed joints.

Casing element in double-wall construction

The casing elements are manufactured as a double-plate construction with a 50 mm sandwich layer of mineral wool insulation. The insulation is made of mineral wool, standard and heavy. The standard wool has the quality of heat-insulation, whereas the heavy wool has the quality of sound-proof. The casing elements consist of 0.7 mm or 1.0 mm aluminium zinc coated sheet steel depending on the size. Alternatively, the wall elements consist of polyester coated galvanized 1.0 mm sheet steel, or a combination of these.



Design, eQ PLUS:

The casing is available in several materials. See our product selection tool ACON. Internal components are available in stainless sheet steel.

Intermediate floor in double deck casing

The intermediate floor is executed as an airtight and stable partition wall in a double-plate construction between the supply air and exhaust air flows, which prevents condensation on the exhaust air side. In the intermediate floor there is 50 min mineral wool insulation.

Sealing strip

Sealing strips made of cellular rubber (EPDM) with closed pores are used for sealing the unit casing. The sealing strip is attached by mechanical means to the intermediate floor and inspection door.

Unit description

Classifications

The coefficient of thermal transmittance, insulation factor, leakage flow and strength of the unit casing are classified according to CEN standard EN 1886. The corrosivity class (environmental class) of the unit casing is classified according to BSK 94/99 and ISO 12944-2 and ISO 9223*.

eQ unit casing conforms to the following classes:

	Class
Thermal insulation (coefficient of thermal transmittance class)	T2 (eQ PLUS) T3 standard insulation
Anti-condensation insulation	TB2 TB3
Air-tightness class (leakage flow)	L2 (CEN B)
Strength class	D2
Corrosivity class (environmental class)	C4 in standard design C5 in stainless design (eQ PLUS)

* For more information, see the Technical Handbook, Air handling technology (ID-number 8629).

Outdoor design

The unit in outdoor design is largely identical to that in indoor design, and both have the same technical data. The outside of the casing is sealed with permanent elastic sealing compound.

The unit is equipped with a convex roof, EQBZ-01, to ensure good water run-off. The roof has a projecting drip edge.

The base frame EQAZ-04 are always used for positioning outdoors. The units should preferably be installed on longitudinal base members or on supports with a max. spacing of 1.5 m.

Units in outdoor design are manufactured only for duct connections on the end walls.

Shunts are positioned in a warm and easily accessible indoor area.

Official testing

The classifications of the eQ unit casing have been verified by measurement at the RWTUv independent laboratory in Germany.

Hygienic design

Even in its basic version, the eQ unit meets very strict hygiene standards. The sides of each module's casing are very smooth, meaning that there are no differences in level between the panel surfaces and the closed frame profiles. There is no ledge at the base of the unit. Large inspection doors allow easy cleaning inside the unit. In the hygiene version of the eQ, the casing is internally sealed between the panels and the frame. This facilitates cleaning and prevents dust accumulation.

- The casing elements have a doublewall construction with a 50 mm thick non-combustible mineral wool insulation providing excellent thermal and acoustic insulation.

- Twin-wall polycarbonate window for easy cleaning and inspection.

- Mechanically secured foam rubber sealing strips in the inspection doors minimise leakage flow.

- The door locks are fitted into the door frame to allow unobstructed airflow and prevent dirt accumulation.

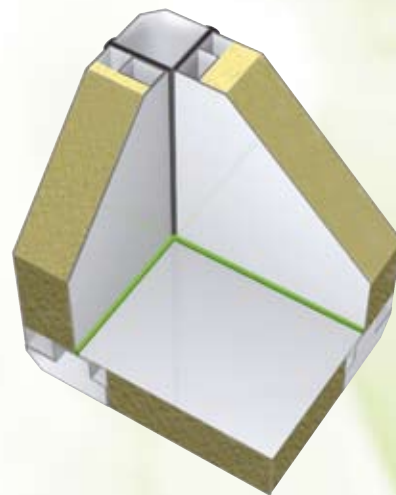

Unit description

Fan

EQLK Plenum fan, Centriflow Plus®

EQLT Plenum fan, Centriflow Plus® for eQ Top

Design

Centriflow Plus® plenum fan, with an efficiency up to 77%. The fans are driven by efficient motors, which give a highly energy-saving unit.

The plenum fan is equipped with 4 measurement points for measurement of the air flow, which give a very high accuracy of measurement. This is important in order to achieve the lowest possible energy consumption. The absence of a fan cover permits easy cleaning. Since the fan can be balanced to produce low levels of vibration, it is suitable for applications where vibration-free running is called for. Outlet direction forwards or upwards.

The eQ range offers several motor options. For the lower flow range we recommend our top choice – EC-motors. EC-motors enable record low energy consumption as well as the shortest installation. We can also offer integral motors, IE2 and conventional motors, IE1 / IE2.

The complete fan unit, mounted on vibration dampers, is permitted to have a vibration velocity of max. 7.1 mm/s measured on the bearing shields of the motor.



Centriflow Plus®

Centriflow Plus® with EC-motor

Material

Vibration dampers made of rubber or steel spring dampers. The fan frame and blades are available as epoxy painted.



Design, eQ PLUS

The frame and wheel are epoxypainted in stainless design.

Unit description

EQLR Centrifugal fan

Design

EQLR is a fan with spiral casing and backward curved blades, i.e. type B impeller. The fan has high efficiency, low sound emission and a stable fan characteristic throughout the recommended working range.

The impellers are designed for high rigidity and strength.

On some unit sizes the motor is placed next to the fan, which enables a short fan block. The complete fan unit (fan, motor, belt drive and base frame), mounted on vibration dampers, is permitted to have a vibration velocity of max. 7.1 mm/s measured on the bearing shields of the motor.

In order to avoid vibrations in the connected duct system or unit sections the outlet of the fan is connected to the casing via a flexible connection (PVC-coated woven glass fibre). All bearings are rated for L10, 40 000 hours operation with 90 % probability at the maximum fan speed. This means that the probable average life expectancy will be good at the fastest rpm but considerably better at a lower rpm.



Material

Vibration dampers made of rubber or steel spring dampers. The hood and wheel can be enhanced with epoxy painting.



Design, eQ PLUS

The frame and wheel are epoxypainted in stainless design.

Double motors internally, single and double motors externally.

Belt drive for centrifugal fan EQLR

The flat belt drive is designed for each combination of fan and motor and for the required speed, so that the motor and fan will have a useful life of at least 40 000 hours and that the belts will have a useful life of at least 25 000 hours.

Unit description

Filter

EQPA Panel filter

Design

Filter cassettes, G4. Filter manufactured from a synthetic material, that is cleanable.

For simple applications, where there are low demands for filtration. A tray drainage is available as an accessory



Design, eQ PLUS

EQPA is available with filter class G2 in aluminium that is cleanable. Available with a drain tray.



EQPB Filter

Design

- Filter cassettes, coarse filter: G4, fine filter F5, F7, F9.
- For other filter classes, replacement filter EQPZ-03 and EQPZ-05 are available.
- Synthetic or glass fibre.
- Can also be provided with a pre-filter G3 and G4.
- Glass fibre filter for lower pressure drop (low SFP_v, energy-saving filter), available for all sizes.
- A stainless tray without drainage is available as an accessory.



Utförande, eQ PLUS

- Compact filter.
- Cityflo (glass fibre and highly active carbon)
- Citycarb (compact and highly active carbon)
- Available with drain tray in stainless sheet steel.



EQPT Filter for eQ Top

Design

Supply and extract air ultra compact filters made of fibreglass. Filter class F5 on the extract air side and F7 on the supply air side.



Unit description

Filter



EQPF HEPA filter

Design

Absolute filter for air handling units with high demands on hygiene. EQPF has a pentented seal to eliminate the risk of leakage. Welded mounting frame in which the filter cassettes are fixed.



EQPK Carbon filter

Design

Filter with active carbon that efficiently absorbs odours.



Unit description

Rotary heat exchanger

EQRA, EQRB REGOTERM[®]/TURBOTERM[®]

Design

- TURBOTERM[®] provides 6% higher efficiency than REGOTERM[®] because of tighter foil spacing.
- Non hygroscopic (heat transfer only).
- Hygroscopic (heat transfer and moisture transfer).
- Sorptions rotor.

Forced air cleaning sector, electronic speed control and rotation sensor.

There is no need for defrosting for normal comfort ventilation. The risk of frost formation may be present at a relative humidity greater than 30% in the exhaust air and an outdoor temperature lower than -15 °C.

The Fläkt Woods ACON product selection tool verifies the need for defrosting.

Material

Rotor in aluminium and frame in casing material.



Design, eQ PLUS

- Sorption rotor
- Edge-reinforcing
- Sectorized and divisible rotor

Plate heat exchanger

EQRC RECUTERM[®]

Design

- Large heat exchanger with section defrosting, which gives the best energy solution.
- Large heat exchanger with or without a by-pass damper.
- Small heat exchanger with a by-pass damper.

Hygiene approved inclined drain tray on the exhaust air side, made of stainless steel.

Droplet eliminator in plastic.

At high atmospheric humidity, a tray (EQRZ-01) may also be required on the supply air side.

Must be defrosted at an outdoor air temperature below ca -7 °C.

Material

Aluminium or epoxy-coated aluminium.



Unit description

Liquid-coupled heat exchanger

EQRT ECONET®

Design

The ECONET® functional section is unique in that it can completely eliminate the need for additional heating coils and cooling coils. The extra energy necessary for heat-ing/cooling is supplied directly in the energy recovery circuit. High-efficiency heat exchangers make it possible to utilise low-grade heat, often in the form of waste heat. The difference between the supply air temperature de-sired and the temperature of the incoming medium can also be kept very low.

Besides the two heat exchangers, the product also includes the following;

- Pump unit
The unit consists of a pump, piping components and necessary sensors. The pump is a multi-stage centrifugal pump driven by a controllable variable-speed motor. The pump casing, impeller and end pieces are made of stainless steel.
- Frequency inverter for controlling the speed of the pump.
- Control unit. The unit consists of a controller that controls the liquid circuit.



Alarm functions that include anti-frost protection are included. If condensation is likely to form on the coil surface and the air velocity exceeds 3 m/s, the coil must be equipped with a droplet eliminator.

The adjustment should be performed by authorized personnel on installation site.

Material

The two heat exchangers, one for supply air and one for extract air, consist of copper tubes and aluminium fins. The droplet eliminator is made of plastic. Both heat exchangers have sloping drain trays made of stainless steel.



Design, eQ PLUS

The ECONET® is available with maximum front-area, in which the entire internal surface is utilized for coil fins and copper headers are placed outside the airstream. In addition, the coils can be ordered in many different material qualities. See our product selection tool ACON or the product code for alternatives.

Unit description

Liquid-coupled heat exchanger

EQRF ECOTERM®

Design

4 output variants.

The exhaust air coil has an inclined drain tray in stainless steel. The droplet eliminator is made of plastic. Withdrawable drain trough is available for size 005-090.

If the risk of condensation is present, and if the air velocity exceeds 3 m/s, the coil should be provided with a droplet eliminator.

Material

Copper pipes and aluminium fins.

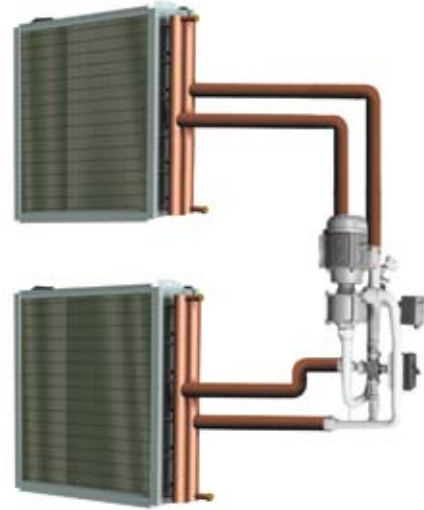

Design, eQ PLUS

The ECOTERM® is available with maximum front area.

In addition, the coils can be ordered in many different material qualities. See our product selection tool ACON or the product code for alternatives.

Heaters/Coolers

EQEE, EQEG, EQKE Air heater for hot water, frost coil

Design

- The air heater has exposed collector pipes.
- Max. operating pressure: 16 bar at a max. operating temperature 100 °C.
- Max. operating pressure: 10 bar at a max. operating temperature of 150 °C.

EQKE is available for duct installation.

Material

Copper pipes and aluminium fins.



Design, eQ PLUS

The air heater can also be ordered in many different material qualities. See our product selection tool ACON or the product code for alternatives.

Unit description

EQEK, EQKK Air heater, electric

Design

- Max surface temperatures: 90°C.
- Voltage: 3 x 230 / 3 x 400 V.
- IP class: IP-43 / IP-55.
- Meets SEMCO, NEMKO requirements.

EQKK is available for duct installation.

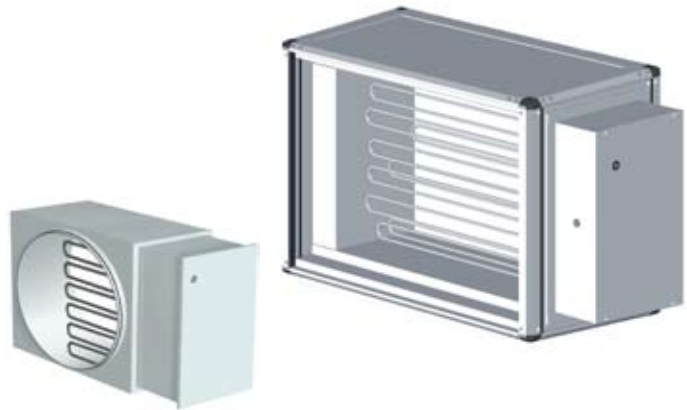

EQNN, EQNP Air cooler

Chilled water, evaporative refrigerant

Design

A water trap for positive or negative pressure is available as an accessory.

- Max. operating pressure: 16 bar at a max. operating temperature of 100 °C (Water).
- Max. operating pressure: 10 bar at a max. operating temperature of 150 °C (Water).
- Max. operating pressure: 22 bar at a max. operating temperature of 100 °C (Evaporative refrigerant).
- Fin pitch 2 mm.

Material

Aluminium fins and copper tubes.
Droplet separator made of plastic.



Design, eQ PLUS

EQNN and EQNP are also available with:
Fin pitch 2,5 and 3 mm.
In addition, the air cooler can be ordered in many different material qualities. See our product selection tool ACON or the product code for alternatives.

Unit description

EQKN, EQKP Air cooler
Chilled water, evaporative refrigerant

Design

- Max. operating pressure: 16 bar at a max. operating temperature of 100 °C (Water).
- Max. operating pressure: 10 bar at a max. operating temperature of 150 °C (Water).
- Max. operating pressure: 22 bar at a max. operating temperature of 100 °C (Evaporative refrigerant).
- Fin pitch 2 mm.

Material

Aluminium fins and copper tubes.
Droplet separator made of plastic.

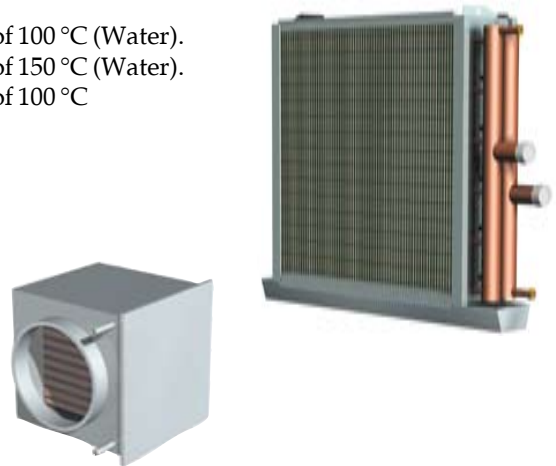

EQHN, EQHP Air cooler in hygienic design

Cooling water or DX

Design

Air cooler for hygiene applications.
Withdrawable drain tray is available. The tray lenas in two directions in order to ensure that all water flows out. It is easily accessible to facilitate cleaning.
EQHN and EQHP meet the requirements according to VDI 6022.

Material

Droplet eliminator in plastic.
In addition, the coil can be ordered in many different material qualities. See our product selection tool ACON or the product code for alternatives.



Unit description

Empty section

EQTB, EQTC Empty section

Design

EQTC

For inspection and maintenance operations and connection of ducts. With or without door.
Connections: Ceiling, bottom, rear side and inspection side.

EQTB

Empty section for air coolers, intended for easier maintenance in hygiene applications.



Design, eQ PLUS

EQTC is available with drain tray.

Jointing frame



EQVH Jointing frame

Design

Jointing frame for installation between modules of different size. Fitted to the larger module.

EQSA, EQSD Silencer

Design

Absorption silencer with baffles.
Non-combustible mineral wool with external protective woven fabric, which prevents fibres from the wool being carried along by the air flow. The baffles are available for wet cleaning.

EQSD is available for duct installation.

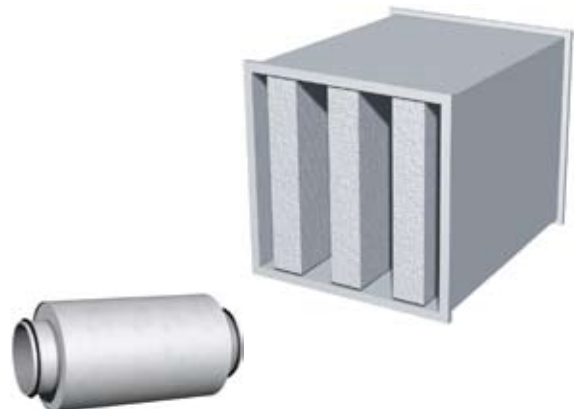

Unit description

Recirculated air section

Design

The function is intended for the circulation and heating of room air, e.g. night-time heating.

It is positioned between the heat recovery unit and the air heater. Available with recirculated air damper only, or with recirculated air damper and exhaust air damper. Internal dampers must be provided with a door.

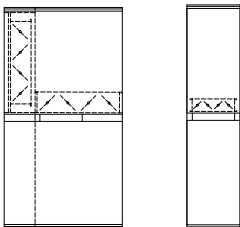

Mixing section

Design

This function is intended for mixing different air flows. The mixing section can have one, two or three dampers depending on the desired function.



EQAZ-12 Damper

Design

- Counter-rotating stable damper blades in double-plate construction with rubber seals made of EPDM.
- The damper shafts rotate in bearings made of acetal plastic. Smaller dampers with toothed wheels and larger dampers with a linkage mechanism.
- Max permissible pressure difference: 1000 Pa when the damper is closed.
- Air-tightness class CEN3 or CEN4. Note! If you want to have a unit in air-tightness class L2 (CEN b) the outside mounted dampers need to fulfil CEN 4.
- A mounted actuator is available as an accessory.
- Insulated damper blades are also available.

At air velocities below 10 m/s, the sound power level is less than 20 dB.

Material

Galvanized sheet steel or stainless sheet steel.



Unit description

Humidifier



EQQA Humidifier for once-through water and circulated water

Design

Intended both for direct humidification of the supply air and for indirect humidification positioned in the extract air part. In the latter case the extract air is cooled evaporatively before a rotary heat exchanger that cools the supply air. Evaporative humidifier with humidifier fill in aluminium for 90% or 60 % humidification rate. EQQA Humidifier is hygienic and economical designed. Its water consumption is minimal and it is a good energy solution.

Material

Humidifier fill in aluminium. The tray is leaning and made of stainless sheet steel.

EQQA Humidifier for circulated water

Design

The water supply is controlled by a built-in solenoid valve. Required supply water flow rate is set on the flow regulator. The bleed-off flow is determined by the water quality and its quality zone is adjusted on the control regulator. To ensure that the water is maintained clean the control system is factory-set for emptying and flushing once a day. For hygienic reasons the control system can also be set to empty the tray after a certain period when there has not been any need for humidification.



EQQA Humidifier for once-through water

Design

Water is supplied to the sprinkler tubes via a pulse valve and a constant flow valve, which ensures the right water application flow rate.

EQQB Empty section

Design

Empty section for steam humidifier. The steam lances are installed on site and the length of the empty section must conform with the recommendations from the steam lances supplier.

Unit description

Cooling unit

EQKA COOLER



Design

The cooling unit is always supplied as a complete, factory-tested unit, with provision for connection to other functional sections. For horizontal airflow only. The cooling unit cools the supply air by means of circulating R407C refrigerant

The cooling unit can be equipped with a mains water-cooled condenser, which is connected upstream of the ordinary air cooled condenser and in series with it.

The water cooled condenser is equipped with water connections and a water saving valve. The water-cooled condenser has sufficient capacity to handle a maximum of 50 % of the total condenser rating of the corresponding output variant.

The condenser is self regulating and provides additional condensing capacity when necessary. No adjustments need be made.

The cooling unit is controlled by an external 0–10 V control signal. The cooling unit contains 2 to 4 compressors, depending on the unit size, and these are switched in three or four output stages.

In the project design work, it is normally presumed that the extract airflow is higher than or equal to the supply air flow, in order to guarantee satisfactory cooling of the condenser. The product selection tool ACON should be used for more precise project design work.

The cooling unit is intended for outdoor air temperatures between +20 °C – +32 °C and a min. supply air temperature of +12 °C.

The cooling unit is not suitable by supply air temperature control unless optional hot gas by pass is fitted.

The Cooler is best controlled by return air or room air temperature set point as supply air temperature control may give rise to stability problems. The three steps of cooling are controlled by a 0–10 V input signal from the AHU controller.

Note: Step control is not suitable for VAV systems.

If condensate is likely to form and the air velocity exceeds 3 m/s, the evaporator must be equipped with droplet eliminator to prevent condensate entrainment.

Material

Evaporator and a condenser with copper tubes with aluminium fins.

The evaporator is equipped with a sloping drain tray made of stainless sheet steel.



Design, eQ PLUS

The COOLER can be ordered in many different material qualities. See our product selection tool ACON or the product code for alternatives.

Unit description

Cooling unit



EQKB ReCooler with cooling recovery

Design

This is a system consisting of a COOLER combined with a hygroscopic rotor. The cooling unit's condenser and subcooling coil is located in the extract air after the rotor. The separate subcooler allows the use of a special type of condenser which is very efficient at partial loads.

The EQKB Cooling unit is always supplied as a complete, factory tested unit, ready for connection to other functional components. The refrigerant is R407C and the unit is intended for a horizontal air flow direction.

When cooling is required and the outdoor air is warmer than the extract air, the supply air is cooled and dehumidified in the rotor. Then the supply air is re-cooled to the desired temperature in the cooling unit's evaporator. When heating is required, the hygroscopic rotor provides high heat and moisture recovery.

The EQKB Cooling unit is controlled by an external 0–10 V signal. The EQKB contains 2 compressors, depending on the size of the air handling unit. These can be switched in three power stages.

To ensure the satisfactory cooling of the condenser project design assumes that the extract airflow is greater than or equal to the supply air flow.

The rotor is operated for cooling recovery when the outdoor air is hotter than the extract air; and for heat recovery when there is a demand for heat.

The cooling unit is intended for outdoor air temperatures between +20 °C– 35 °C and a minimum supply air temperature +12 °C.

The cooling unit is not suitable for supply air temperature control, unless an optional hot gas bypass is fitted. The cooling unit is best controlled by the setpoint of the extract air or room air temperature, as supply air temperature control may give rise to stability problems.

In the event of condensation and air speeds above 3 m/s, the evaporator must be equipped with a drip separator.

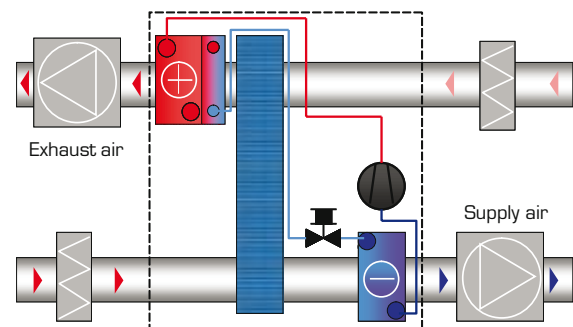

Material

Evaporators, condensers and subcoolers are made of copper pipe with aluminium fins. The evaporator is equipped with a sloping stainless steel drain tray. The rotor is made of aluminium.

Unit description

Cooling unit

EQKC Combi Cooler



Design

The Combi Cooler is a ready-to-install functional part with an internal cabinet for all control and safety apparatus. Only the electrical power supply and the control signals required from superordinate control systems need to be connected to the installation site. Each Combi Cooler is factory tested and the test report is included in the delivery.

The EQKC Combi Cooler is a liquid cooler from Fläkt Woods which is integrated into the air handling unit. It is optimised for use in conjunction with a chilled beam system. The Combi Cooler cools water which is then used to cool supply air and a chilled beam circuit. The Combi Cooler can also produce cold water for the chilled beam circuit at the same time as it heats the supply air using heat from an external system.

Functions

- 1) Controlling the supply air temperature: both heating and cooling.
- 2) Produces cold water for an internally mounted supply air coil.
- 3) Produces cold water for room-based cooling.

Room-based cooling is carried out either using chilled beams, fan convectors or cassette chilled beams. The Combi Cooler has a supply air coil that operates as a heating coil as well as a cooling coil. The integrated shunt group regulates heating or cooling to the supply air coil as necessary. The network of chilled beams is connected by its own pipes to the Combi Cooler, which produces cold water for them.

When using the Combi Cooler, all refrigeration components are installed in the plant room. No separate liquid coolers or roof-mounted condensers are needed with the Combi Cooler. Because these are not needed, external condenser pipes and their pumps need not be routed to the roof. Because the appearance of the building is not changed, renovation is easier, and at the same time noisy condenser fans are not needed.

The Combi Cooler is most appropriate where room-based cooling is carried out using chilled beams and the cooling power is a maximum of 50 W/m². In general this cooling power is sufficient in normal office and business premises.

In traditional solutions the supply air temperature is 15-16° C, while in the Combi Cooler it is 18° C. Because the supply air temperature is slightly higher, areas such as empty meeting rooms maintain a comfortable temperature with no heating load.

Material

Evaporator and a condenser with copper tubes with aluminium fins. The cooling coil is equipped with a inclined drain tray in stainless sheet steel. Water heat exchanger is made of copper/stainless steel.
Isolation: Armaflex.

Unit description

Climate control system



Control unit Twin Wheel



Design

Twin Wheel is a system with a hygroscopic rotor, a cooling coil and a sensible rotor. When cooling is required and the outdoor air is warmer than the extract air, the supply air is cooled in two stages. The hygroscopic rotor cools and dehumidifies the supply air. In the cooling coil, the air is cooled to the desired humidity level and reheated to the optimal supply air temperature in the sensible rotor. This system significantly cuts down on cooling energy compared to traditional systems where all the cooling energy is supplied in the cooling coil.

The system is suitable when there is a need for cooling and humidity control, especially in facilities with chilled beams where a low humidity level is required in the supply air. If heating is required, the double rotors have such a high recovery degree that a heating coil is usually not necessary.

Functions

- The outer rotor pre-cools the supply air thus reducing the need to use a cooling coil and cooler.
- The outer hygroscopic rotor transfers moisture from the supply air to the extract air. This reduces the amount of moisture that must be removed in the cooling process, making it possible to use smaller coils and coolers.
- The need for a heating coil is dramatically reduced. The inner rotor recycles enough heat from the extract air – which means free heat most of the year!
- The Twin Wheel system works outstandingly together with chilled beams and fan convectors. It reduces the risk of condensation forming on the chilled beams thanks to its use of energy efficient technology.

Unit description

Motors

To obtain a high total efficiency for the fan it must have a highly efficient motor and have the optimum combination of fan, motor and transmission for the application. The ACON air handling unit selection program is an excellent aid in obtaining data related to total efficiency and operating costs etc. eQ fans can be fitted with many different types, configurations and makes of fan.

Main types of motor

- Asynchronous motors
- Integral motors
- DC motors (single or two speed)

Asynchronous motors

3-phase motors in one or two speed configurations. This motor, which is also known as an induction motor, copper wire coils generate a rotating magnetic flux. The core of the rotor is laminated and consists of aluminium rods.

eQ fans are available in the following configurations:

Number of poles:

- Single speed version with 2, 4, 6 or 8 poles
- Two speed version with 2/4, 4/6, or 4/8 poles.

Intended for belt drive centrifugal fans.

Supply voltage, 3-phase:

- 220-230 V
- 380-400V
- 400-415 V
- 500 V

Temperature monitors:

- With a thermo-contact trip
- With a thermistor

Efficiency classes for single speed motors:

- IE1
- IE2



Centriflow Plus® with asynchronous motor

The new standard covers motors as follows:

- Single speed, 3-phase, 50 Hz and 60 Hz
- 2, 4 or 6 poles
- Rated output from 0.75 to 375 kW
- Rated voltage Un up to 1000 V
- Duty type S1 (continuous operation) or S3 (intermittently periodic operation)
- Can be supplied with power directly from a 50 or 60 Hz grid

These are the new efficiency classes defined in accordance with the IEC 60034-30:2008 standard, see diagram below.

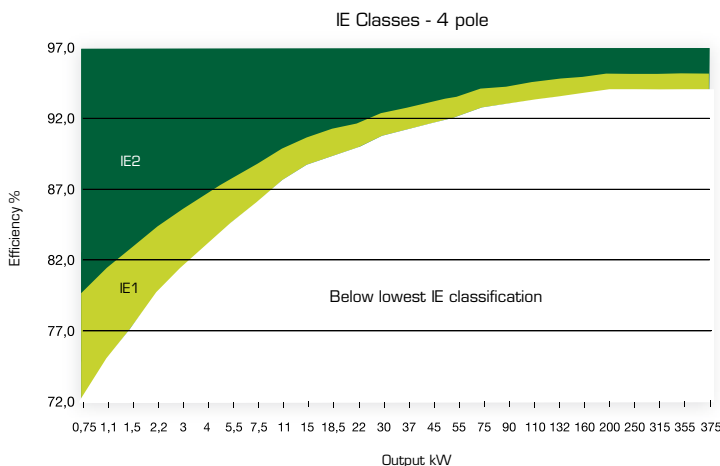

Unit description

Integral motors

The integral motor is an asynchronous motor with an integrated frequency converter.

This results in negligible sensitivity to interference in contrast to motors with a separate frequency converter and a cable between the motor and frequency converter.

The motor is available as an IE2 version with 2 or 4 poles and a rated output up to 7.5 kW. Supply voltage 400–415 V, 3-phase. The speed is controlled by a 0–10 V signal.



Centriflow Plus® with integral motor

DC motors (EC)

The EC motor is a DC motor with electronic commutation. This means that the motor speed can be controlled very effectively. The motor speed is controlled by how rapidly the magnetic flux in the motor switches. The permanent magnets of the rotor create the magnetic flux in the motor. Speed control is carried out using a control unit integrated with the motor. Control signal 0–10 V. Start at 1.4 V and stop at <1 V. The EC motor is efficient throughout its operating range and is brushless, requiring less maintenance.



Centriflow Plus® with DC-motor

Characteristics

- The same or greater efficiency as the integral motor.
- Maintains its efficiency during downwards speed regulation.
- Silent
- Smaller physical dimensions
- 1-phase power supply at low power

The motor is available for the direct drive of plenum fans with a rated output up to 3 kW and supply voltages of 1x230 V and 3x400 V.

Control equipment

ControlMaster

The ControlMaster is a complete control system for Fläkt Woods' ventilation units. The flexible equipment is available both as a compact standard design and as a classic customised solution for wall mounting or integration into the air handling unit.

Simplicity

The ControlMaster has been developed to be easy to plan, install and use. Because of this an eQ air handling unit with a factory installed control system is a practical solution for consultants, installation engineers and end users.

The integrated control equipment is supplied programmed, configured and tested, together with all the necessary field components. Of course the control system conforms to EU directives (MD, EMC and LVD) and is CE marked.

The ControlMaster is the perfect solution for both small installations with straightforward control functions, and also for large installations with data communication requirements.

Communication

The ControlMaster supports communication via open standard protocols, which allows its simple and cost effective integration with building automation systems. Connection to other systems is carried out by the system integrator.

Easy project design

Using ACON the project design of the ControlMaster system is straightforward. This program automatically selects the control equipment for the unit you have chosen. Shunts are dimensioned for the relevant air heater and air cooler. Frequency converters are dimensioned for the relevant motor, drive system and fan. A simple yet effective solution that saves time.

Quick installation

Not only is time saved on project design but also on installation. The ControlMaster is self-contained and requires no major on-site electrical installation. The control equipment is ready to go as soon as the unit is installed.

High quality

Installing a control system for a high quality air handling unit requires experience and expertise of air handling. The ControlMaster has been designed by the same team that designed the eQ and eQ PLUS, with a focus on design details that give good insulation, little leakage and low noise. The production of the ControlMaster is characterised by a rigorous quality assurance system to ensure an approved and electrically safe product. Naturally the standardised design is also a guarantee of cost effectiveness, reliability and high quality.



Control equipment

Delivery options

ControlMaster - Standardised

Compact standard control cabinet

- Flexible standard design
- Standard control unit
- Control cabinet integrated into a fixed panel/ceiling
- Field components mounted if possible

Compact terminal block interface

- Flexible standard design
- Supplied without a control unit
- Terminal block interface integrated into a fixed panel/ceiling
- Field components mounted if possible

ControlMaster PLUS - Customer adapted

ControlMaster PLUS offers a wide range of solutions for installations with specific and stringent flexibility requirements; for example the choice of incorporated components, electrical enclosures and design, as well as functions over and above those available in ControlMaster. Because this is not always in stock, delivery times might be longer.

External control cabinet

- Order based design
- User-selectable control unit
- Control cabinet for wall mounting
- Field components are supplied

Built-in control cabinet

- Order based design
- User-selectable control unit
- Control cabinet integrated into the unit
- Field components mounted if possible

Terminal block interface

- Flexible terminal block interface, e.g. for its own controller
- Supplied without a control unit
- Electrical equipment cubicle integrated into the unit
- Field components mounted if possible

Functions

- Temperature control
- Frequency converter operation for constant air flow or duct pressure
- On-demand control
- Heating and cooling shunts
- CO₂ control
- Fire protection functions
- Control of different types of heat exchanger
- Energy measurement
- Control of extra fans
- Control of temperature zones
- Preheaters
- Communication via OPC, BACnet, LonWorks or Modbus
- Monitoring via a web interface

Control equipment

ControlMaster

Regulator

The ControlMaster is characterised by the high quality of its component parts, because it is based on quality components from some of the leading manufacturers in the field. At its heart is one of the market's most powerful digital controllers. The software has been specially developed for Fläkt Woods, and contains all the functionality that could be needed for an air handling unit. All functions are ready for activation, although some need add-on hardware.

The control system is supplied with a simple, easy to use control panel. All functions are displayed in plain text in the desired language. The menu structure is logical and easy to understand. All settings, such as desired temperature setpoint or timer switch settings can be made from the control panel. From here it is also possible to read off the operating values and any alarms.

The control panel is handheld, but has a magnetic mount and is supplied with a 2 metre long cable.

Without control unit

The ControlMaster can also be supplied without a control unit. This means that wiring must be routed from all electrical components in the ventilation unit to terminal blocks in the electrical equipment cubicle. This concept allows the simple connection of an external control system and the high quality integration of the electrical installation.

Location

As standard, the air handling unit's electrical equipment cubicle is located in a fixed panel by one fan, apart from for the 005-011 unit which is located in the ceiling for reasons of space. As an alternative the electrical equipment cubicle can be located on an empty section anywhere on the unit (option).

All incoming cables are connected to the electrical equipment cubicle either from above or below. For outdoor units connection from below is recommended. Cable routing in double deck casings is internal, while for single deck casings the wiring is located externally. Cable ducts made of injection moulded aluminium are available as an accessory.

Quick connectors

The unit is equipped with quick connectors for auxiliary equipment in the direct proximity of the unit; damper actuator, sensors, valve actuator, control panel for the control cabinet. In addition, in units divided into blocks there are internal quick connectors to facilitate installation.

Lighting

Factory installed unit lighting is best supplied with power from the control system. In addition to a switch on the unit the lighting can be operated in parallel with the lighting in the plant room. If the lighting is left on, it is switched off automatically after 4 hours.

Technical data

- Control circuit for pumps, 1-phase or 3-phase, max. 3A
- Auxiliary transformer for 24 VAC
- Speed-controlled or direct started motors
- EC motor, integral motor, frequency converter for fan operation
- Speed controller for regulating the speed of the heat exchanger rotor
- Day/Week timer built-into the control unit.
- Battery backup in the event of a loss of power supply 72 hours.

The terminal block for incoming supply is rated for:

- Max 4 mm²/25 A
- Max 16 mm²/63 A
- Max 25 mm²/80 A.

The following are used internally in the unit

- 2.5 mm² for power distribution up to 16 A/fan.
- 6 mm² for power distribution up to 31 A/fan.

External fuse protection

External fuse protection must always be carried out to conform to the legislation of each country. In order to calculate maximum power consumption, the currents of the fans are aggregated with other loads. The latter are internally protected by 10 A fuses.



Control equipment

ControlMaster PLUS

The standard version of the ControlMaster PLUS is supplied with one of the following control units.

Climatix 600

This control unit is specially developed for air handling units. The software has been developed for Fläkt Woods and contains most of the functions that a ventilation unit requires. The unit, which is modular, is intended for installation on a DIN rail. Depending on the functionality required, the control unit can be expanded with I/Os and communication modules.

Several different operator panels are available for the control unit. The simplest is intended for handheld use, but is fitted with a magnetic mount. It has ingress protection class IP31. It is operated using a knob and keys. An operator panel with ingress protection class IP54 is recommended for outdoor use and in tough environments. This is operated using keys.

Xenta 300

The Xenta 300 is a freely programmable controller intended for small and medium air handling units. It has full HVAC functionality including control loops, graphs, time control, alarm management etc. When required the controller can be expanded with I/O modules. The ControlMaster PLUS with Xenta 300 is supplied with unit-specific software. The operator panel for work on-site has a display and is operated using keys. It is used to read of values and adjust parameters.

Without control unit

The ControlMaster PLUS can also be supplied without a control unit. This means that wiring must be routed from all electrical components in the ventilation unit to terminal blocks in the electrical section. This concept allows the connection of external control systems.

Technical data

As standard the ControlMaster PLUS is supplied for:

- 3 x 400 VAC, 50 Hz, 5-conductor system.
- 3 x 230 VAC, 50 Hz, 4-conductor system (Norway).

The control cabinet contains the following components where applicable:

- Main circuit breaker
- Automatic fuse for control voltage
- Contactors for fans and pumps
- Control transformer for 24 VAC
- Motor circuit breaker triggered thermally and magnetically
- Mode switch
- Timer switch with back-up (included in the control unit)
- Terminal blocks for sensors and actuators inside and outside the unit
- Terminal block for an external summation alarm
- Terminal blocks for prolonged operation
- Documentation
- Pocket for drawings
- Group designation



Control equipment

Technical data

Testing

The unit is supplied as fully connected internally. The insulation and performance of controls for each unit are tested prior to delivery. In addition, a factory setting is made for as many parameters as possible.

Standards

The control system conforms to the following standards and regulations:

- Machinery Directive 98/37/EC, Electrical equipment of machines, EN 60 204-1.
- EMC Directive 89/336/EEC, Adjustable speed electrical power drive systems EN 61800-3, EMC EN 61000-6-3:2001 (emissions) and EN 61000-6-2:2001 (immunity).
- Low Voltage Directive 72/23/EEC [DF2], Electronic equipment EN 50178.

Environmental Requirements

Operation:	Temperature	0...50°C
	Relative humidity	< 85 % RF

If there is a risk of the temperature dropping below 0 °C, for outdoors units for example, the control cabinet can be fitted with a heater. Indicate this when ordering.

Connection data

The control system can be supplied for the following supply voltages. The power supply cable must be fitted with an external load interrupter, which can cut the power to the entire unit. The load interrupter is available as an accessory.

- 3 x 230 ±10% VAC, 50 Hz, 4-conductor system (Norway).
- 3 x 400 ±10% VAC, 50 Hz, 5-conductor system.

Control equipment

Power consumption, plenum fan

Maximum power consumption per fan

Output (kW)	3-400 VAC			3-230 VAC	1-230 VAC
	Frequency converter	Integral motor	DC motor	Frequency converter	DC motor
	Continuous current [A]	Input current [A]	Continuous current	Continuous current [A]	Continuous current [A]
0.18	-	-	-	-	-
0.25	-	-	-	-	-
0.37	-	-	-	-	-
0.55	-	1.5	-	-	3.3
0.75	2.4	1.8	-	4.6	-
1.1	3.3	2.5	-	6.6	-
1.2	-	-	1.8	-	-
1.5	4.1	3.4	-	7.5	-
1.7	-	-	2.5	-	-
2.2	5.4	4.7	-	11.8	-
3	6.9	6.4	-	-	-
3.1	-	-	4.9	-	-
4	8.8	8	-	16.7	-
5.5	11.9	12	-	24.2	-
7.5	15.4	15.5	-	30.8	-
11	23	-	-	46	-
15	31	-	-	59	-
18.5	38	-	-	75	-
22	45	-	-	88	-
30	59	-	-	114	-
37	72	-	-	143	-
45	87	-	-	178	-
55	125	-	-	221	-
75	157	-	-	248	-
90	180	-	-	-	-
110	205	-	-	-	-

Control equipment

Power consumption, centrifugal fan

Maximum power consumption per fan

Output (kW)	Asynchronous motor IE1			
	3x230VAC		3x230VAC	
	Motor current [A] 2- /4- /6-pol	Frequency converter Current [A] 2- /4- /6-pol	Motor current [A] 2- /4- /6-pol	Frequency converter Current [A] 2- /4- /6-pol
0.18	- / - / -	- / - / -	- / - / -	- / - / -
0.25	- / - / -	- / - / -	- / - / -	- / - / -
0.37	1.7 / 2 / 2.1	2.4 / 2.4 / 2.4	1 / 1.1 / 1.2	2.4 / 2.4 / 2.4
0.55	2.5 / 2.7 / 2.9	3.3 / 3.3 / 3.3	1.4 / 1.6 / 1.7	2.4 / 2.4 / 2.4
0.75	3.1 / 3.4 / 4.1	3.3 / 4.1 / 4.1	1.8 / 2 / 2.4	2.4 / 2.4 / 2.4
1.1	4.3 / 4.7 / 5.6	5.4 / 5.4 / 6.9	2.5 / 2.7 / 3.2	3.3 / 3.3 / 3.3
1.5	5.8 / 6 / 6.8	6.9 / 6.9 / 6.9	3.4 / 3.5 / 3.9	4.1 / 4.1 / 4.1
2.2	7.9 / 8.4 / 9.4	8.8 / 8.8 / 11.9	4.6 / 4.8 / 5.4	5.4 / 5.4 / 5.4
3	10.4 / 11.2 / 12.5	11.9 / 11.9 / 15.4	6 / 6.5 / 7.2	6.9 / 6.9 / 8.8
4	13.6 / 14.9 / 16.4	15.4 / 15.4 / 23	7.9 / 8.6 / 9.4	8.8 / 8.8 / 11.9
5.5	18.2 / 19.2 / 21.5	23 / 23 / 23	10.5 / 11.1 / 12.4	11.9 / 11.9 / 15.4
7.5	24.6 / 25.6 / 27.2	31 / 31 / 31	14.2 / 14.8 / 15.7	15.4 / 15.4 / 23
11	36 / 38.3 / 39.8	38 / 45 / 45	20.8 / 22.1 / 23	23 / 23 / 23
15	48.5 / 50.4 / 53.7	59 / 59 / 59	28 / 29.1 / 31	31 / 31 / 31
18.5	59.2 / 63.2 / 63.4	72 / 72 / 72	34.2 / 36.5 / 36.6	38 / 38 / 38
22	68.8 / 72.7 / 74.5	72 / 87 / 87	39.7 / 42 / 43	45 / 45 / 45
30	95.4 / 102.2 / 97	125 / 125 / 125	55.1 / 59 / 56	59 / 59 / 59
37	116.2 / 117.8 / 119.5	125 / 125 / 125	67.1 / 68 / 69	72 / 72 / 72
45	138.6 / 145.5 / 147.2	157 / 157 / 157	80 / 84 / 85	87 / 87 / 87
55	- / 169.9 / 178.4	- / 180 / 180	- / 98.1 / 103	- / 125 / 125
75	- / 239 / -	- / 245 / -	- / 138 / -	- / 157 / -
90	- / 280.6 / -	- / - / -	- / 162 / -	- / 180 / -
110	- / 351.6 / -	- / - / -	- / 203 / -	- / 205 / -

Control equipment

Power consumption, centrifugal fan

Maximum power consumption per fan

Output (kW)	Asynchronous motor IE2			
	3x230VAC		3x230VAC	
	Motor current [A] 2- /4- /6-pol	Frequency converter Current [A] 2- /4- /6-pol	Motor current [A] 2- /4- /6-pol	Frequency converter Current [A] 2- /4- /6-pol
0.18	- / - / -	- / - / -	- / - / -	- / - / -
0.25	- / - / -	- / - / -	- / - / -	- / - / -
0.37	- / - / -	- / - / -	- / - / -	- / - / -
0.55	- / - / -	- / - / -	- / - / -	- / - / -
0.75	3 / 3.1 / 3.3	3.3 / 3.3 / 3.3	1.8 / 1.8 / 1.9	2.4 / 2.4 / 2.4
1.1	4.2 / 4.3 / 4.8	5.4 / 5.4 / 5.4	2.4 / 2.5 / 2.8	2.4 / 3.3 / 3.3
1.5	5 / 5.4 / 6.4	5.4 / 5.4 / 6.9	2.9 / 3.1 / 3.7	3.3 / 3.3 / 4.1
2.2	7.6 / 8.1 / 10.2	8.8 / 8.8 / 11.9	4.4 / 4.7 / 5.9	5.4 / 5.4 / 6.9
3	10.2 / 10.9 / 13.2	11.9 / 11.9 / 15.4	5.9 / 6.3 / 7.6	6.9 / 8.8 / 8.8
4	12.6 / 14.9 / 18.2	15.4 / 15.4 / 23	7.3 / 8.6 / 10.5	8.8 / 8.8 / 11.9
5.5	18.5 / 19.4 / 22.9	23 / 23 / 23	10.7 / 11.2 / 13.2	11.9 / 11.9 / 15.4
7.5	23.6 / 26.5 / 27	31 / 31 / 31	13.6 / 15.3 / 15.6	15.4 / 15.4 / 23
11	33.3 / 36.4 / 39.8	38 / 38 / 45	19.2 / 21 / 23	23 / 23 / 23
15	45 / 49.4 / 53.7	45 / 59 / 59	26 / 28.5 / 31	31 / 31 / 31
18.5	56.3 / 60.6 / 63.2	59 / 72 / 72	32.5 / 35 / 36.5	38 / 38 / 38
22	67.5 / 71 / 72.7	72 / 72 / 87	39 / 41 / 42	45 / 45 / 45
30	90.1 / 95.3 / 98.7	125 / 125 / 125	52 / 55 / 57	59 / 59 / 59
37	110.9 / 117.8 / 123	125 / 125 / 125	64 / 68 / 71	72 / 72 / 72
45	- / 142 / 143.8	- / 157 / 157	- / 82 / 83	- / 87 / 87
55	- / 173.2 / -	- / 180 / -	- / 100 / -	- / 125 / -
75	- / 237.3 / -	- / 245 / -	- / 137 / -	- / 157 / -
90	- / 280.6 / -	- / - / -	- / 162 / -	- / 180 / -
110	- / - / -	- / - / -	- / - / -	- / - / -

DC motor		
Output (kW)	Max current (A)	Voltage (VAC)
0.55	3.3	1x230
1.2	1.8	3x400
1.7	2.5	3x400
3.1	4.9	3x400

Integral motor	
Effekt (kW)	Max current (A) 2- /4-pol
0.55	- / -
0.75	1.8 / 1.7
1.1	2.3 / 2.5
1.5	3.4 / 3.3
2.2	4.5 / 4.7
3	5 / 6.4
4	8 / 8
5.5	12 / 11
7.5	15 / 15.5

Control equipment

Standard functions

Speed control

The ControlMaster can manage both direct started motors and motors with speed control. Speed control can be obtained using a separate frequency converter or using an actuator integrated with the fan motor. Two different setpoints can be handled for each fan. The following control types are available for speed control. The necessary sensors are included.

Flow control

The setpoints for the supply air fan and extract air fan are set in the control unit. Two setpoints for each fan allow the switching of fan speed using a clock, timer, push button or occupancy detector.

Function: maintaining flow in the duct system.

Pressure control

The setpoints for the supply air fan and extract air fan are set in the control unit. Two setpoints for each fan allow the switching of fan speed using a clock, timer, push button or occupancy detector.

Function: maintaining pressure in the duct system.

Note! The unit can be supplied with pressure control of one fan and slave-controlled flow control of the other.

CO₂ control

The speed of the supply air fan is controlled by a CO₂ sensor so that a set threshold is not exceeded. The extract air flow is given flow compensation. Sensors are available for duct mounting and room mounting.

Adjusting the drive system

The drive systems for the supply air fan and extract air fan are factory set. The setpoints are corrected on the control unit control panel.

Temperature control

Temperature control can be carried out using two different setpoints for both heating and cooling. This means that a comfort mode and an economy mode can be obtained. The air heater, heat exchanger and any air cooler and mixing section are controlled in sequence. The following options are available for the ControlMaster. The necessary temperature sensors are included.

Supply air control

Function: maintaining the temperature in the supply air duct at the set setpoint.

Extract air control

Function: maintaining the temperature in the extract air duct at the set point value, through the cascade control of the supply air temperature using minimum and maximum restrictions.

Room control

Function: maintaining the temperature in the premises at the set point value, through the cascade control of the supply air temperature using minimum and maximum restrictions.

Seasonal temperature control

- Function winter: maintaining the temperature in the supply air duct at the set setpoint.
- Function summer: maintaining the temperature in the extract air duct at the set point value, through the cascade control of the supply air temperature using minimum and maximum restrictions.
- Summer mode applies between two variable dates. At other times of the year winter mode applies, unless the outdoor temperature exceeds a set threshold value.



Control equipment

Other functions

Night purging (free cooling)

The night purging setting is used during the summer, outside ordinary operating periods, in order to cool the premises with cool outdoor air at night.

Function: As both the room temperature and outdoor temperature exceed the set threshold value and the difference between these threshold values exceeds the set differential, the unit is started in order to cool the premises using fresh outdoor air. The post cooler is not activated. Outdoor sensors and room sensors are included.

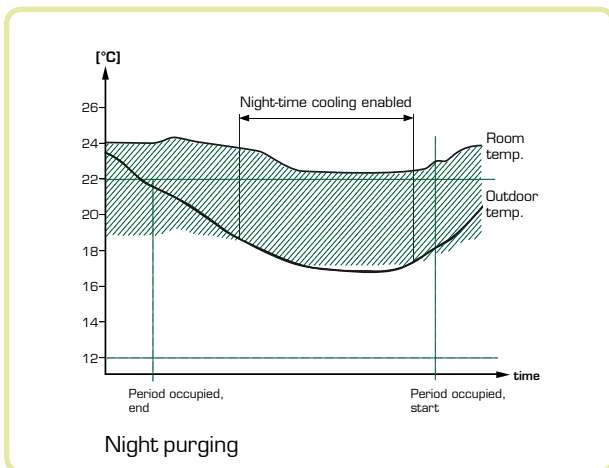

Night heating

Night heating is used to prevent the premises from being cooled during the night outside the normal operating time.

Function: the unit starts with full power from the air heater if the room temperature drops below the set value. If the unit is equipped with a mixing/return air damper this is opened to reduce energy consumption, while the outdoor air and extract air dampers remain closed. Room sensors included.

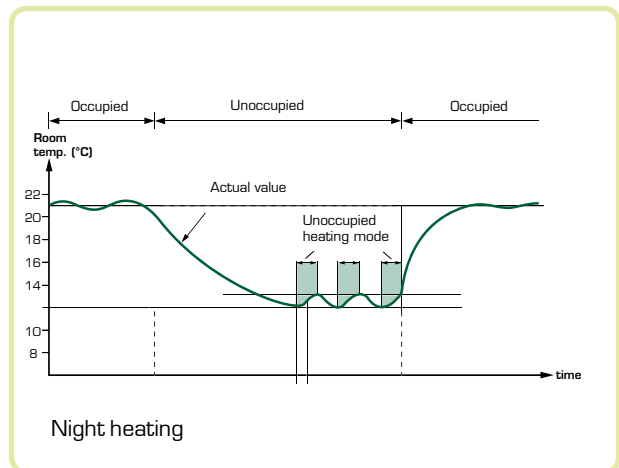

Cooling recovery

Function: starts the rotary heat exchanger at full recovery for cooling the supply air, when the extract air temperature is lower than the outdoor air temperature and there is a need for cooling. Outdoor temperature and extract air sensors included.

Weather compensated temperature setpoint

Function: offsets the set setpoint for supply air, extract air or room temperature using a four point graph coupled to the outdoor temperature.

Setting: set the four break points on the control unit. Outdoor temperature sensor included.

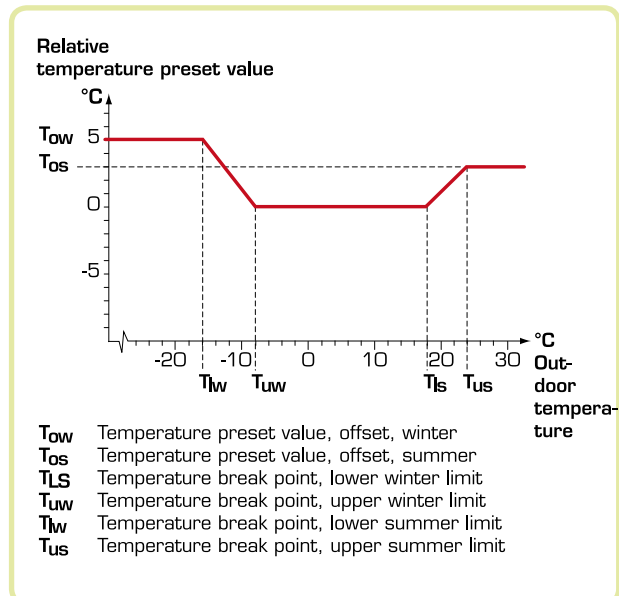

Control equipment

Weather compensated flow/pressure setpoint

One way of preventing the cooldown of the premises is to reduce the flow/pressure when the outdoor temperature drops. To prevent the heating of the premises when outdoor temperatures are high, the flow/pressure is increased as the outdoor temperature rises. The flow/pressure setpoint is adjusted, regardless of whether the heat exchanger and heater are at full power, using a four point graph linked to the outdoor temperature. The speed of both fans is adjusted to prevent negative pressure in the building.

Setting: set the four break points and the maximum and minimum flow/pressure on the control unit. Outdoor temperature sensor included.

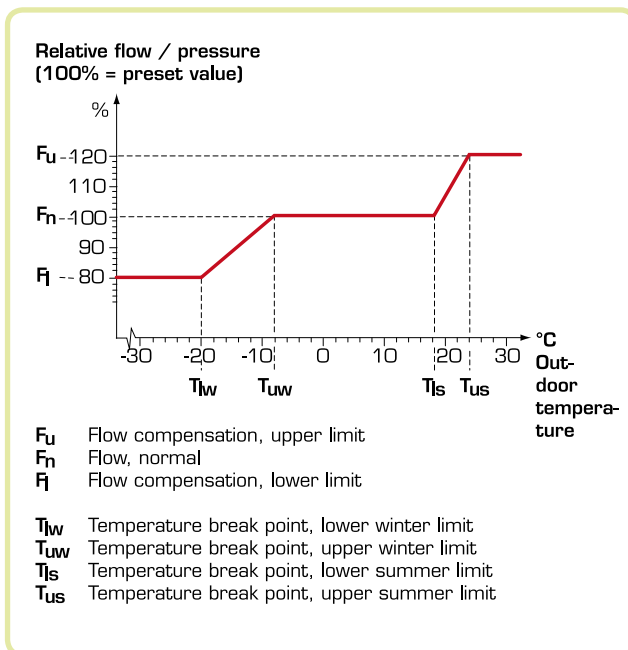

Outdoor temperature controlled fan speed

One simple way of avoiding the cooldown of premises is to prevent the forcing of fans when the outdoor temperature falls below a set value.

Setting: set the break point for the outdoor temperature in the control unit. Outdoor temperature sensor included.

Note! Normally the heat exchanger starts as soon as there is a heat demand. If there is an additional heat demand the air heater is also utilised. Where the heat exchanger and afterheater are at full power, but there is still a need for more heat, the supply air temperature will drop. By reducing the air flow last in the sequence, the air can be heated more despite the air heater producing the same output. If necessary, this function can be activated in retrospect for the ControlMaster with Climatix 600, because no extra sensor is required.

External components

Controlling the air heater

Control signal 0–10 V DC for valve actuator or electric air heater with built-in thyristor and stepping switch if fitted.

Control of air cooler

Control signals for different types of cooling:

- 0–10 V DC for air cooler, water or Cooler.
- Closing switch for 1, 2 or 3 steps (binary) DX cooling (direct expansion).

Control of combined air heater/air cooler

Control signal 0–10 V DC for combined air heater and air cooler, which cools during the summer and heats during the winter. The switch between summer mode and winter mode can take place based on the date, outdoor temperature, system temperature in the water circuit or external signal.

Circulation pump for air heater or air cooler

The circulation pumps for heating, cooling and the coil heat exchanger can be supplied with power from the control cabinet. Maintenance operation is carried out via control panel. Separate alarms from each pump, e.g. a thermo-contact trip, can be connected to the unit electrical equipment cubicle. The pumps should be clog resistant. A maximum 3A single phase supply is available for the ControlMaster. One of the pumps can also be supplied with a maximum 3 A 3-phase (option).

Valve and valve actuator

The ControlMaster can be supplied with both valves and valve actuators for controlling the fluid flow to the heating coil, cooling coil and through the coil heat exchanger. Depending on the valve size (Kvs value) both electromechanical and electrohydraulic actuators can be used.

Damper actuator

Damper actuators intended for mounting on on/off dampers and modulating dampers are available as accessories. Spring return damper actuators should be used for units equipped with water coils to ensure that the dampers close in the event of a loss of power.

Control equipment

Alarm management

Filter monitoring

The pressure drop across filters or prefilters can be monitored using filter monitors connected to the air handling unit control unit. If the actual filter pressure drop exceeds the set value an alarm is generated.

Flow monitoring

To ensure the air flow through the unit, the measured values from flow sensors are monitored so that a flow alarm is generated if the measured value deviates from the current setpoint by more than is permissible. If the unit is not equipped with flow sensors the air flow can still be assured using flow monitors. These generate an alarm if the flow is less than that set for the fan. The alarm is blocked when the fan is switched off. A flow monitor for the supply air is standard if there is an electric heater. The alarm stops the unit.

Fire protection functions

The unit can be equipped with functions to prevent the spread of combustion gas. As standard the unit is stopped and an A alarm is generated. Alternatively the operating signal to one or both of the fans can continue.

Frost protection

The air heater for heating water is equipped with frost protection. Function: when the unit is not in operation the water temperature is maintained at 25 °C. During operation the valve is controlled so that the return temperature does not fall below 12 °C. If the temperature falls below 5 °C the unit stops and an alarm is generated. Frost protection sensor included.

Thermal overload protection

Electric air heaters are equipped with built-in thermal overload protection. As standard the air heater is equipped with a thermostat which cuts the current if the temperature of touchable surfaces exceeds 90–100 °C, for example when the air flow is low. This thermostat resets automatically. In addition there is a temperature limiter, for disaster protection, which cuts the current to the heating elements before dangerous overheating can occur, for example if the fan stops. This thermostat is reset manually and is normally set at 120–150 °C. The alarm stops the unit. A alarm.

Operation

In the ControlMaster the startup and shutdown of the unit, including the selection of setpoints, are managed by the control unit via the built-in calendar function (internal time channels). When the unit is started the dampers in the supply and extract air sides normally open first. These dampers close following a normal shutdown and in the event of a loss of power. During heat recovery the supply air fan starts after the extract air fan.

Prolonged and forced operation can be obtained using a timer, push button or occupancy detector.

Timer low speed

- Function: start of the unit at low speed or switch to low speed when the unit is running at high speed.
- Setting 0...2 hours.
- Intended for surface or recessed mounting.

Timer high speed

- Function: start of the unit at high speed or switch to high speed when the unit is running at low speed. If both timer inputs are active at the same time, high speed is dominant.
- Setting 0...2 hours.
- Intended for surface or recessed mounting

Push button

- Function: start at low speed or high speed in accordance with the timer high or low speed function.
- The time is set in the unit control unit, 0...12 hours.
- Intended for surface mounting.

Presence detector

- Function: start at low speed or high speed in accordance with the timer high or low speed function.
- Delay setting 2...15 min.
- Intended for surface mounting.

Control equipment

Rotary heat exchanger

The heat exchanger starts automatically to blow itself clean when there is no heat demand. The built-in rotation monitoring activates an alarm if the rotor is stationary when there is a heat demand or during cleaning mode. Defrosting via a pressure monitor is available as an accessory. Defrosting is started when the pressure drop across the heat exchanger has increased to the value set on the pressure monitor. During defrosting the heat exchanger is regulated to its minimum

Plate heat exchanger

Section defrosting

Section defrosting is activated at outdoor temperatures below $-7\text{ }^{\circ}\text{C}$. The heat exchanger is defrosted continuously by closing the bypass damper and then closing the recirculation dampers for 15 minutes in order to defrost by section.

Cold corner defrost

Frosting is avoided by limiting the temperature in the cold corner of the heat exchanger to $+2\text{ }^{\circ}\text{C}$, by reducing the heat exchanger efficiency, i.e. progressively opening the bypass damper

Liquid-coupled heat exchanger

At temperatures below the value set in the temperature sensor in the inlet duct, approximately $-5\text{ }^{\circ}\text{C}$, the valve actuator regulates towards the closed position.

ECONET®

The control system for the ECONET® is simply combined with the unit control system. The transfer of the necessary information for the ControlMaster with Climatix 600 us via data communication, but for Xenta traditional I/Os are used.



Mixing

In properties where this is acceptable mixing can be used to reduce energy consumption. The mixing section can be controlled from the air handling unit's control unit for return air at night, or as a part of the control sequence with a maximum restriction of the CO_2 concentration. Mixing can be placed before or after the air heater in the control sequence, depending on the energy saving versus comfort requirement.



Control equipment

Frequency converter

Speed control using a frequency converter is an environmentally friendly control method which reduces energy consumption. By controlling the speed exactly to match demand, energy consumption can be reduced by 50% compared to throttle control.

CAV and VAV systems

In CAV systems a frequency converter is often used to maintain the flow irrespective of changes in pressure drop, arising from the clogging of filters for example. In this case flow control is a suitable option.

Frequency converter operation with pressure control is recommended for CAV systems.

VAV systems use pressure control, if necessary with flow compensation for the extract air to maintain the balance in the system if there is an extra extract air fan.

The frequency converter is also an excellent tool for adjusting the flow, and can eliminate the need to replace belt gear to change the air flow. However, this can have a certain negative effect on optimum efficiency.

Test operation

A frequency converter in the ControlMaster concept is installed in accordance with the applicable EMC standards. The converters are factory tested and the most important parameters are set and checked.

Technical benefits

The comprehensive protective functions in the converter include everything from component level protection to motor overload protection. The monitoring of control signals and overcurrent, overvoltage, undervoltage, thermal overload, short-circuit and earth fault protection are standard functions which increase safety and reduce maintenance.

A soft-start function, along with a frequency converter, reduces wear on the V-belt, coupling and fan.

Built-in frequency converter

The ambient temperature for the frequency converter during operation is limited to 0...40 °C. To protect the frequency converters on an outdoor unit against cold and heat, these can be integrated into a terminal box, EQEL. Alternatively the frequency converters must be mounted elsewhere in the building.

Choice of frequency converter and motor

The optimum efficiency of the drive system is achieved when the frequency converter, motor, transmission and fan are designed and optimised for a common operating curve.

This type of optimization achieves considerably better efficiency than dimensioning all the component parts separately.

When selecting a motor and frequency converter using the ACON air handling unit selection program, the motor is always dimensioned for hypersynchronous operation. Take the following into account when dimensioning and selecting a system without software support.

Depending on the required system, CAV or VAV, Fläkt Woods has developed a method in which the correct SFP value, SFP_V or SFP_{VAV} , are used when dimensioning the belt gear, converter and motor.



Control equipment

Dimensioning

- The rated current of the converter must be equal to or greater than that of the motor.
- The rated output must be greater than the power requirement of the fan.
- The thermal load capacity of the motor must be taken into account

The thermal load capacity of the motor primarily affects the motor output during subsynchronous operation below 50 Hz, in which case the motor should be oversized, in accordance with the diagram below:

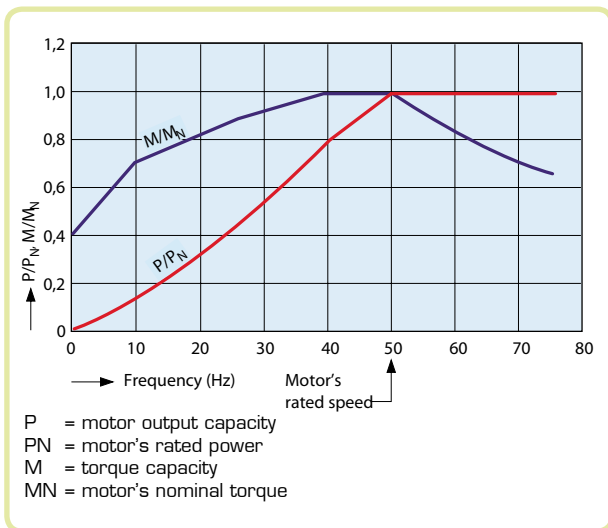

As the above diagram shows the thermal load capacity of the motor, expressed as torque, drops for frequencies above 50 Hz. However, because speed increases with frequency, the thermal load capacity of the motor expressed as power is constant for these frequencies. For frequencies below 50 Hz the torque capacity drops again, and thus power capacity drops even more rapidly because the speed decreases at the same time.

Therefore, this must be particularly taken into account when the motor is running at a subsynchronous speed at full power. In order to take account of this, use the K factor for the subsynchronous dimensioning of motors in accordance with the diagram overleaf. Subsynchronous dimensioning is particularly relevant for direct drive fans.

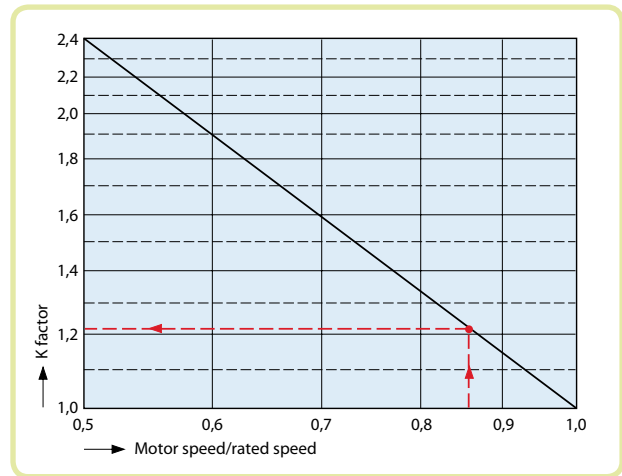

Example, subsynchronous dimensioning of motor:

- Fan speed at the current flow = 2,500 rpm
- Necessary power at 2,500 rpm = 3.8 kW
- Motor rated speed = 2,900 rpm
- Engine speed / rated speed 2,500 / 2,900 = 0.86
- K factor according to the diagram = 1.22
- Minimum motor output $1.22 * 3.8$ = 4.6 kW
- Select the next larger standard motor = 5.5 kW

The following table can be used as a rule of thumb for hypersynchronous fan operation:

Maximum speed in converter operation with maintained power (50 Hz mains frequency)				
Motor size	2-pole	4-pole	6-pole	8-pole
112-132	4,800 (85Hz)	2,500 (85Hz)	1,700 (85Hz)	1,250 (85Hz)
160-200	4,500 (77Hz)	2,500 (85Hz)	1,700 (85Hz)	1,250 (85Hz)
225-250	3,600 (61Hz)	2,500 (85Hz)	1,700 (85Hz)	1,250 (85Hz)

Note that the specified maximum speed only applies if the maximum current of the motor/converter is not exceeded.

Control equipment

Transformer

To allow the use of integral motors and EC motors intended for 3x400 VAC in Norway, where this voltage is not available, a transformer that converts 3x230 V to 3x400 V+N is needed.



Full transformer

The full transformer is to be used in sites with an indirectly earthed mains supply. The transformer forms a TN system on the secondary side which means that no modification is required to the Swedish configuration.

Communication

There are many communication possibilities for the ControlMaster; for connecting accessories, connection to monitoring systems or connection to the internet and mobile services.

Base communication for the ControlMaster

An eQ with integrated control system always includes a simple web server and Modbus and OPC connections. The integrated web server displays the same information that is available in the handheld terminal. Everything that can be changed in the handheld terminal can also be changed in the web interface. No special software is needed to utilise this function, just a normal computer with a web browser, (such as Internet Explorer). The web server can be connected to a standard local TCP/IP network, and then the unit can be monitored from any computer in the local network. If there is no network one can either install a cable between the unit and the computer, or use a GSM modem.

Primary protection

The transformer must be provided with primary protection. This consists of a conventional micro circuit breaker connected to the 230 V incoming supply to the transformer to protect it from overload. Fläkt Woods do not supply primary protection. The installation engineer will provide the necessary equipment.

Standards

The transformers conform to the following standards and regulations:

- Low voltage directive, LVD 73/23/EEC, 93/68/EEC EN 61558-2-4:1997
- EMC directive 89/336/EEC, 91/263/EEC, EN 61000-3-2:1995, EN 61000-3-3:1995

Enclosure

As standard the transformer is supplied in an IP23 sheet-metal casing for a maximum ambient temperature of 40 °C.

Power kVA	Weight (kg)	Length (mm)	Width (mm)	Height (mm)
12.5	96	481	450	590
16.0	122	481	450	590
20.0	148	481	450	590
25.0	170	599	550	630
40.0	200	670	520	827

Thanks to the built-in TCP/IP connection the ControlMaster for eQ is ready for integration into a monitoring system via OPC. OPC is an open industry standard which simplifies the integration of different products in the same system via a common interface. The OPC server is installed on the monitoring computer. The Modbus interface can either be utilised to connect a monitoring system or to connect accessories (such as an energy meter) to the control system. There are two potential connections for Modbus, TCP/IP and RS-485. If the internal connection over RS-485 is used as a master and, at the same time, the unit control is the slave of a master system, a communications module must also be used.

Control equipment

Protocols

Depending on the control unit used, the control system can be equipped for communication with the following protocols. The communication protocols available for the ControlMaster and Climatix 600 are:

BACnet

The ControlMaster with Climatix 600 can be equipped with a communications module for integration into a BACnet system. BACnet is an open global standard, especially developed for building automation. Connection is via TCP/IP.

LonWorks

Communication via LonWorks is available as an accessory for both Climatix 600 and Xenta. Connection to the ControlMaster is via FTT-10. The eQ is equipped with automatic transmission of all SNTVs which allows easy commissioning. The LonWorks image for the eQ has 64 SNTVs.

Modbus RTU

The Modbus RTU is an open de facto industry standard for connection via RS-485. The ControlMaster with Climatix 600 can be equipped with a communications module for Modbus RTU, allowing connection to a master system, at the same time as the integrated Modbus connection is used internally in the unit for the connection of accessories.

Web server with screens

There is a more advanced web application available for Climatix 600, with the same function as a conventional monitoring system, but at a considerably lower price. In addition to web pages this module contains a mail client which can transmit alarms from the unit as e-mail.

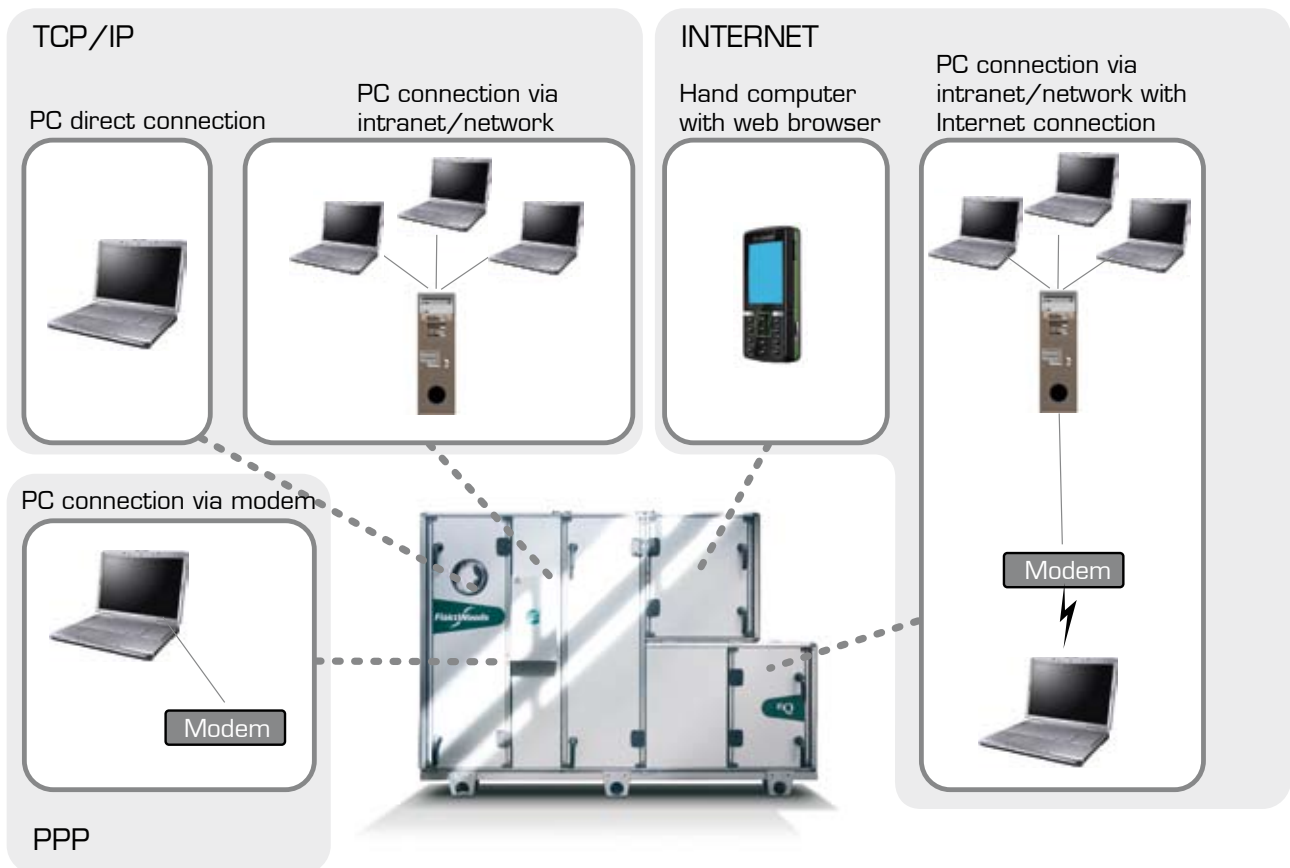

Control equipment

Fire protection functions

Fire/smoke system, FICO-128

The FICO-128 is a suitable choice for fire/smoke systems with more than 2 fire dampers.

Function: monitoring of fire dampers and smoke detectors. The fire dampers are exercised every 48 hours. During exercise the unit is interlocked. Stopping the unit following an A alarm. In the event of an equipment malfunction a B alarm is generated.

Control and monitoring unit for fire/combustion gas
The unit is built into a plastic enclosure with a glazed front panel of ingress protection class IP66 and is CE marked.

Technical data:

- automatic performance test
- manual performance test
- summation alarm A following a triggered detector
- summation alarm B following a damper or detector malfunction
- relay contact for interlocking the ventilation unit
- 24 VAC supply to the damper actuator
- unit power supply, 230 VAC.



Function: the unit is interlocked when the summation alarm is sent to the corresponding terminal block in the unit electrical equipment cubicle. Following an activated alarm the unit stops. However, it is possible to still send operating signals to one or both fans.

Multibox FCBA-2

Multibox FCBA-2 is intended for use together with main unit FICO-128. It can manage two dampers and is mounted in the unit.

Technical data:

- Built-in transformer, 230 VAC
- Intended for 1–2 fire dampers
- Screw and quick connection of damper actuators
- Manual exercise by button
- LED indication of damper position
- Smoke detector status
- Fault indication for easy fault-tracing
- Dimensions: 180 x 130 x 60 mm (W x H x D)

Control equipment

Smoke detector

Smoke detector for duct mounting with an optical function for connection to the control and monitoring unit. The section being inserted (the venturi tube) must be cut to the correct length.

Technical data:

- the cable for 24 V power supply and alarms must be connected to the monitoring unit.
- permissible ambient temperature -10 °C to +50 °C.



Combustion gas unit, FCMA-2

The FCMA-2 control unit can manage smoke detectors, fire thermostats and up to two fire dampers. During damper exercise, which takes place every 48 hours, the ventilation unit is stopped.

Fire alarm (A alarm) stops the unit and in the event of an equipment malfunction a B alarm is generated. Supply voltage 230 V. Ingress protection class IP54.



Control unit for smoke detectors, ABAV 230

The control unit is designed to meet the requirements set to provide dependable fire protection together with our smoke detectors. It has relay contacts for controlling dampers and fans. A fire alarm stops the unit.

Technical data:

- Supply voltage 230 V
- Indications and relays for
 - Smoke alarm
 - Service alarm
 - Fault alarm: short-circuit/open-circuit
- DIN installation



Control equipment



Energy measurement

There is an accessory for the ControlMaster for monitoring instantaneous electrical power and total accumulated electrical energy consumption from startup. The measuring unit also contains a resettable meter (cf. trip meter) for electrical energy consumption. The values are presented in the unit's control unit. The incoming supply is connected through the energy meter, which can cope with a maximum cable cross-sectional area of 16 mm² for currents up to 64A. Current coils are used for larger currents.

Accuracy of measurement:

- Class 1 conforming to EN 62053-21 and MID Annex MI-003 Class B
- Class 2 conforming to EN 62053-23

Extra temperature zones

In order to control more than one temperature zone, the ControlMaster can be supplemented with controllers for up to four zones. These zone controllers handle heating and cooling in sequence, as well as supply air tempera-

ture control and cascade control. If a water coil is used for heating this should be provided with a frost protection sensor. The zone controllers for the ControlMaster are supplied in separate wall cabinets that exchange information with the unit via data communication. This means that setpoints, parameters and current operating values are processed via the unit controller's control interface.

Extra fans

The ControlMaster can be supplemented to manage up to four external fans. The fan controllers manage both directly started and speed controlled fans. The latter can control both pressure and flow. The control unit for external fans for the ControlMaster is supplied in a separate wall cabinet. Data communication allows a regular exchange of information with the unit's control unit. So setpoints, parameters and current operating values can be managed via the unit controller's control interface.

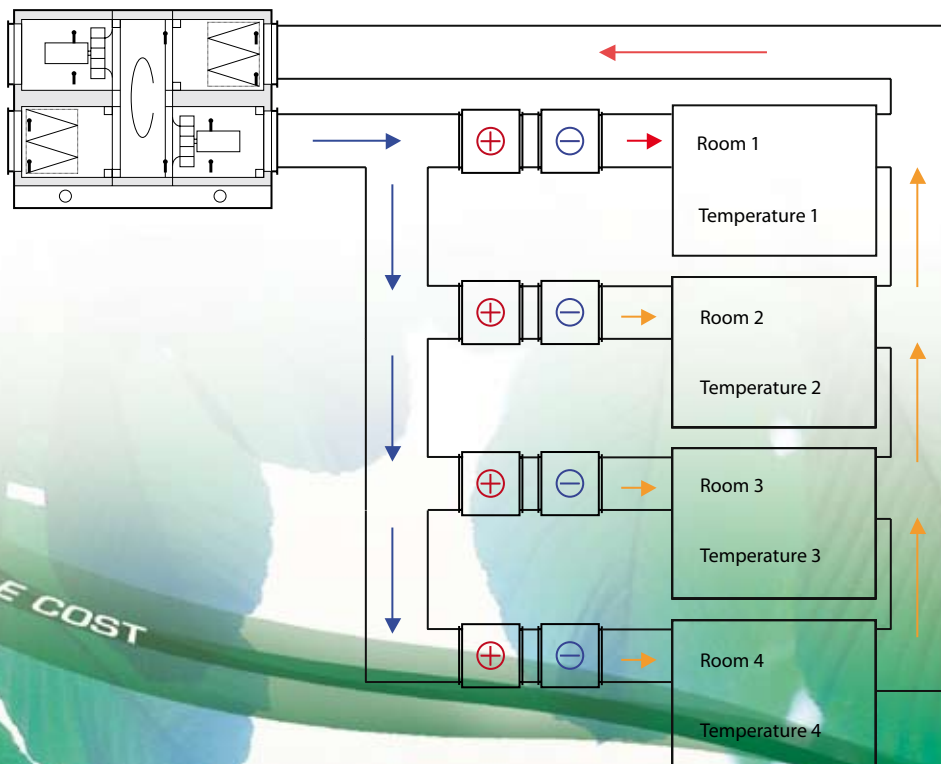

Flow charts

Supply air unit without heat exchanger

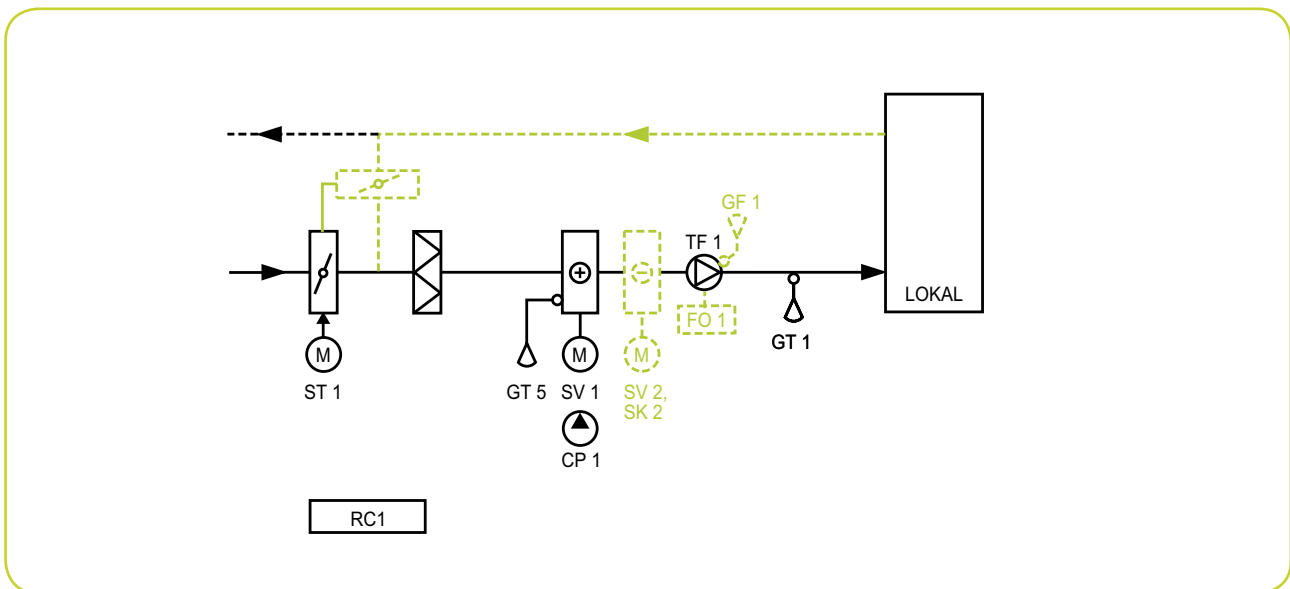

Component list

CP1	Circulation pump, heating water	ST1	Damper actuator, outdoor air
FO1	Frequency converter	SV1	Valve actuator, heating water
GF1	Flow sensor, supply air	SV2/SK2	Valve actuator cooling/stepping switch, cooling
GT1	Temperature sensor, supply air	TF1	Supply air fan
GT5	Frost protection sensor, air heater		
RC1	Control unit		

Function

TF1 is started and stopped by the timer built-into RC1. Mode switches along with operation and alarm indication are contained in the operator panel. Damper actuator ST1 opens before TF1 starts and closes when the fans stop.

Temperature control

The temperature sensor GT1 maintains the desired supply air temperature using RC1 that controls the air heater. If there is a heat demand valve actuator SV1 opens. If there is a cooling demand SV1 closes.

Air heater, heating water

If there is a risk of frost in the air heater, the frost protection sensor GT5 makes valve actuator SV1 open, after that the unit is stopped. When the unit is stopped, GT5 maintains the return water temperature at approx. 25 °C.

Alarm

Frost protection (A alarm), Motor protection fan, supply air (B alarm). Summation alarm to terminal block

Control panel

- Climatix 600
- Xenta 300

Options (light green in the flow chart)

Mixer component

Mixing dampers are controlled in sequence by valve actuator SV1.

Air cooler, cooling water

The air cooler valve actuator SV2 is controlled in sequence with the air heater and any mixing damper.

Air cooler, evaporated refrigerant

Stepping switch SK2 switches on the air cooler for the evaporated refrigerant in one or more stages using a stepping or binary switch, in sequence with the air heater and any mixing damper.

Flow control, fan

Flow sensor GF1 maintains the flow through the supply air fan. Frequency converter FO1 controls the speed of TF1.

Flow charts

Supply air unit without heat exchanger

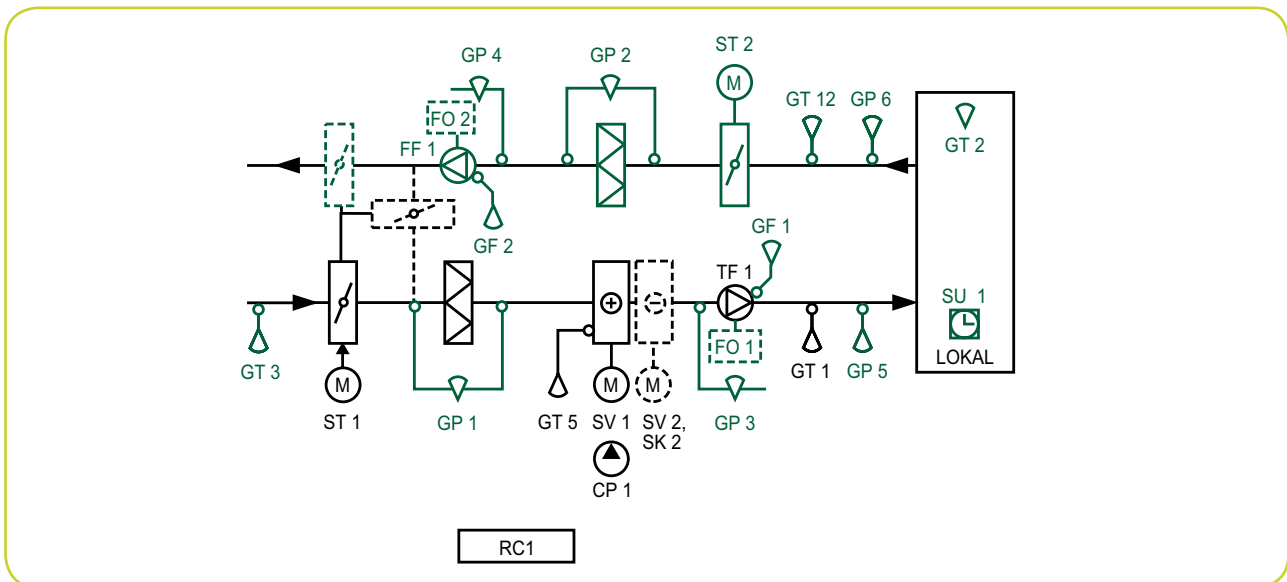

Component list

FF1	Extract air fan	GP5	Pressure sensor, supply air
FO1	Frequency converter	GP6	Pressure sensor, extract air
GF2	Flow sensor, extract air	GT2	Temperature sensor, room
GP1	Pressure monitor, supply air filter	GT3	Temperature sensor, outdoor air
GP2	Filter monitor, extract air	GT12	Temperature sensor, extract air
GP3	Pressure monitor, supply air flow	ST2	Damper actuator
GP4	Pressure monitor, extract air fan	SU1	Timer

Accessories (dark green in the flow chart)

Room or extract air control

Room or extract air temperature is maintained by controlling the supply air temperature in a cascade limited to a min. and max. value.

Pressure control, fans

Pressure sensors GP5/GP6 maintain the air pressure in the ducts. Frequency converters FO1/FO2 control the speed of TF1/FF1.

Outdoor compensation

The desired air temperature setpoint is offset upwards or downwards at high and low outdoor temperatures respectively.

Filter monitor, supply and extract air

Generates an alarm if the pressure drop across each filter exceeds the set value (B alarm).

Flow monitor, supply and extract air

Stops the unit and generates an alarm if the flow is low (B alarm).

Damper actuator

For dampers other than the outdoor air damper.

Fire protection function

Stops the unit in the event of an alarm (A alarm).

Night purging

Starts the unit at night to cool the premises using cold outdoor air. Outdoor sensor for facade mounting.

Night heating

The unit starts automatically at night to heat the premises if the temperature inside is low.

Extended Operation

Prolonged operation via a timer or external push button with a time set on the panel.

Extra extract air fan

Contact and motor protection for extract air fans being controlled in parallel with the unit's supply air fan, or in continuous operation, or manually via an external switch.

Shunts

Shunt with pilot valve and pump group for the air heater or air cooler for heating water and cooling water.

Flow charts

Supply air unit without heat exchanger

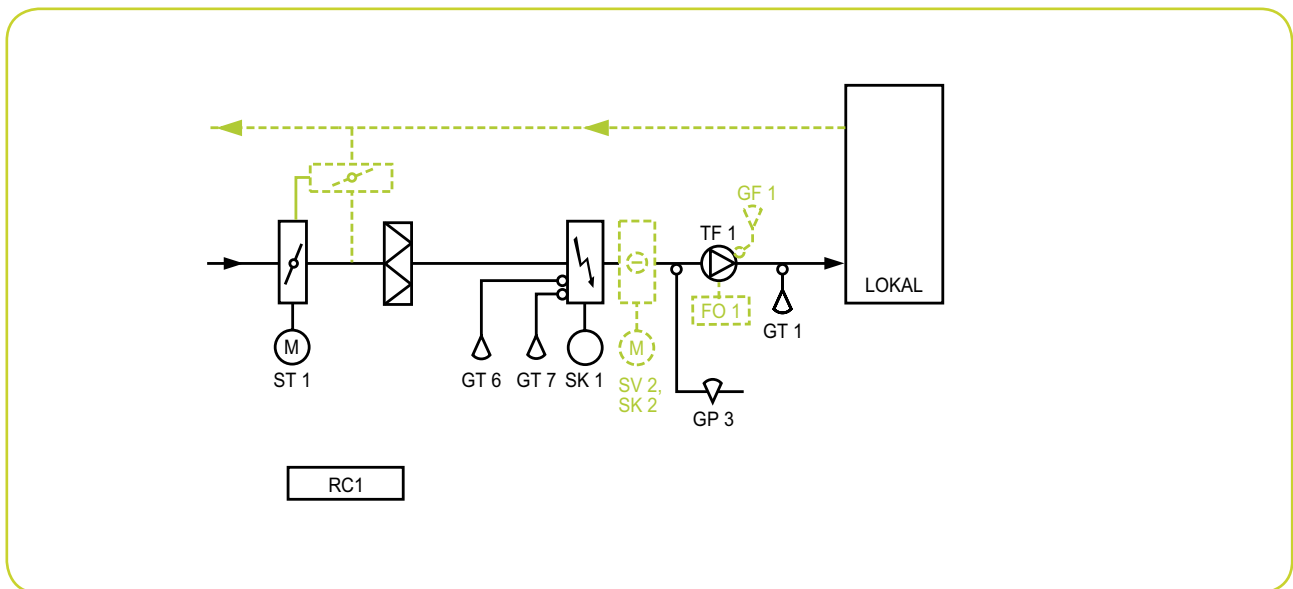

Component list

FO1	Frequency converter	RC1	Control unit
GF1	Flow sensor, supply air	SK1	Stepping switch or thyristor actuator
GP3	Pressure monitor, supply air	ST1	Damper actuator, outdoor air
GT1	Temperature sensor, supply air	SV2/SK2	Valve actuator cooling/stepping switch, cooling
GT6	Thermal overload protection, automatic	TF1	Supply air fan
GT7	Thermal overload protection, manual		

Function

TF1 is started and stopped by the timer built-into RC1. Mode switches along with operation and alarm indication are contained in the operator panel. Damper actuator ST1 opens before TF1 starts and closes when the fans stop.

Temperature control

The temperature sensor GT1 maintains the desired supply air temperature using RC1 that controls the electric heater. If there is a heat demand the stepping switch/thyristor SK1 are tied in. If there is a cooling demand SK1 is disconnected.

Air heater, electric

The air heater is interlocked by TF1 and fan monitor GP3. When the unit is stopped by a switch, timer or thermal overload protection, the electric heater is disconnected immediately while the fans continue to run for a set time to cool the unit.

Alarm

Thermal overload protection (B alarm), motor protection fan, supply air (B alarm). Flow switch supply air (B alarm). Summation alarm to terminal block.

Control panel

- Climatix 600
- Xenta 300

Options (light green in the flow chart)

Mixer component

Mixing damper ST3 is controlled in sequence with stepping switch/thyristor SK1.

Air cooler, cooling water

The air cooler valve actuator SV2 is controlled in sequence with the electric air heater and any mixing damper.

Air cooler, evaporated refrigerant

Stepping switch SK2 switches on the air cooler for the evaporated refrigerant in one or more stages using a stepping or binary switch, in sequence with the electric air heater and any mixing damper.

Flow control, fan

Flow sensor GF1 maintains the flow through the supply air fan. Frequency converter FO1 controls the speed of TF1.

Flow charts

Supply air unit without heat exchanger

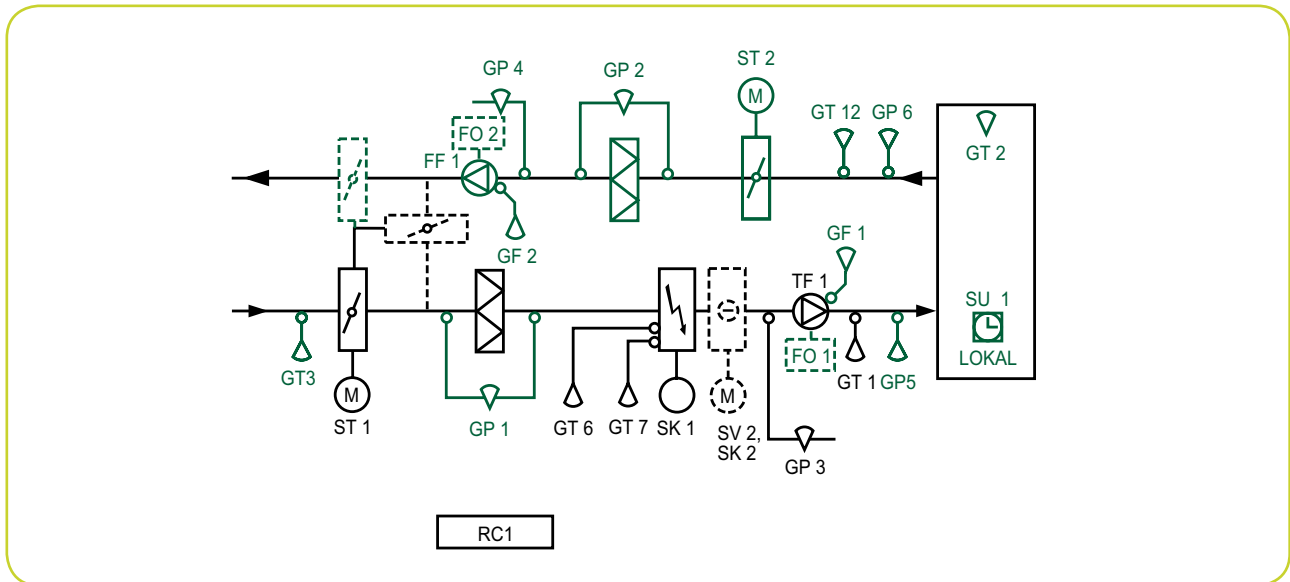

Component list

FF1	Extract air fan	GP6	Pressure sensor, extract air
FO2	Frequency converter	GT2	Temperature sensor, room
GF2	Flow sensor, extract air	GT3	Temperature sensor, outdoor air
GP1	Filter monitor, supply air	GT12	Temperature sensor, extract air
GP2	Filter monitor, extract air	ST2	Damper actuator
GP4	Pressure monitor, extract air	SU1	Timer
GP5	Pressure sensor, supply air		

Accessories (dark green in the flow chart)

Room or extract air control

Room or extract air temperature is maintained by controlling the supply air temperature in a cascade limited to a min. and max. value.

Pressure control, fans

Pressure sensors GP5/GP6 maintain the air pressure in the ducts. Frequency converters FO1/FO2 control the speed of TF1/FF1.

Outdoor compensation

The desired air temperature setpoint is offset upwards or downwards at high and low outdoor temperatures respectively.

Filter monitor, supply and extract air

Generates an alarm if the pressure drop across each filter exceeds the set value (B alarm).

Flow monitor, extract air

Stops the unit and generates an alarm if the flow is low (B alarm).

Damper actuator

For dampers other than the outdoor air damper.

Fire protection function

Stops the unit in the event of an alarm (A alarm).

Night purging

Starts the unit at night to cool the premises using cold outdoor air. Outdoor sensor for facade mounting.

Night heating

The unit starts automatically at night to heat the premises if the temperature inside is low.

Prolonged operation

Prolonged operation via a timer or external push button with a time set on the panel.

Extra extract air fan

Contact and motor protection for extract air fans controlled in parallel with the unit's supply air fan, or in continuous operation, or manually via an external switch.

Shunts

Shunt with pilot valve and pump group for cooling water for the air cooler.

Flow charts

Supply air unit and extract air units with a rotary heat exchanger

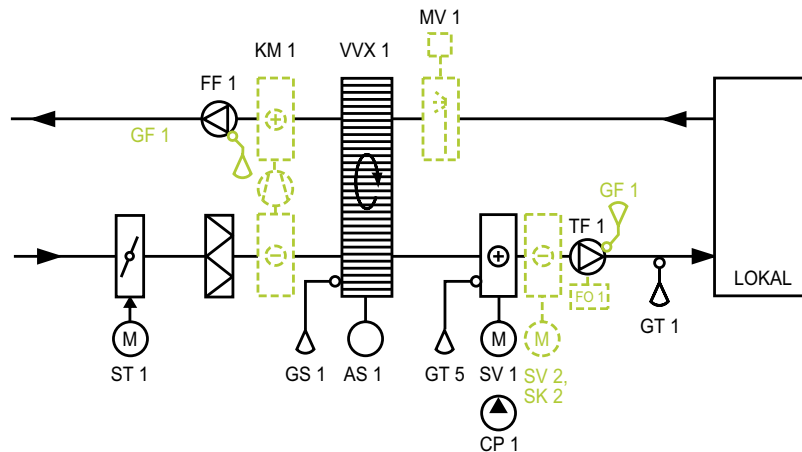

Component list

AS1	Speed controller heat exchanger	KM1	Cooler
CP1	Circulation pump, heating water	MV1	Solenoid valve
FF1	Extract air fan	RC1	Control unit
FO1/FO2	Frequency converter	ST1	Damper actuator, outdoor air
GF1	Flow sensor, supply air	SV1	Valve actuator, heating water
GF2	Flow sensor, extract air	SV2/SK2	Valve actuator cooling/stepping switch, cooling
GS1	Rotation monitor sensor	TF1	Supply air fan
GT1	Temperature sensor, supply air	VWX1	Rotary heat exchanger
GT5	Frost protection sensor, air heater		

Function

TF1/FF1 are started and stopped by the timer built-into RC1. Mode switches along with operation and alarm indication are contained in the operator panel. The extract air fan starts before the supply air fan. Damper actuator ST1 opens before TF1 starts and closes when the fans stop.

Temperature control

The temperature sensor GT1 maintains the desired supply air temperature using RC1 that controls the heat exchanger and air heater in sequence. If there is a heat demand the AS1 speed controller increases the speed of the rotor and valve actuator SV1 opens. If there is a cooling demand SV1 closes and AS1 slows the speed of the rotor.

Air heater, heating water

If there is a risk of frost in the air heater, the frost protection sensor GT5 makes valve actuator SV1 open, after that the unit is stopped. When the unit is stopped, GT5 maintains the return water temperature at approx. 25 °C.

Alarm

Frost protection (A alarm), motor protection fan, supply and extract air (B alarm), rotation monitor VVX (B alarm). Summation alarm to terminal block.

Control panel

- Climatix 600
- Xenta 300

Options (light green in the flow chart)

Air cooler, cooling water

The air cooler valve actuator SV2 is controlled in sequence with the heat exchanger and air heater.

Air cooler, evaporated refrigerant

Stepping switch SK2 switches on the air cooler for the evaporated refrigerant in one or more stages using a stepping or binary switch, in sequence with the heat exchanger and air heater.

Cooler

When the room/extract air temperature exceeds the set value RC1 transmits a signal to air cooler KM1 which switches on one or more stages.

Indirect evaporative cooling

When the outdoor temperature exceeds the set value the rotor is started at maximum speed and solenoid valve MV1 in the water pipe is opened.

Flow control, fans

Flow sensor GF1/GF2 maintains the flow through each fan. Frequency converters FO1/FO2 control the speed of TF1/FF1.

Flow charts

Supply air unit and extract air units with a rotary heat exchanger

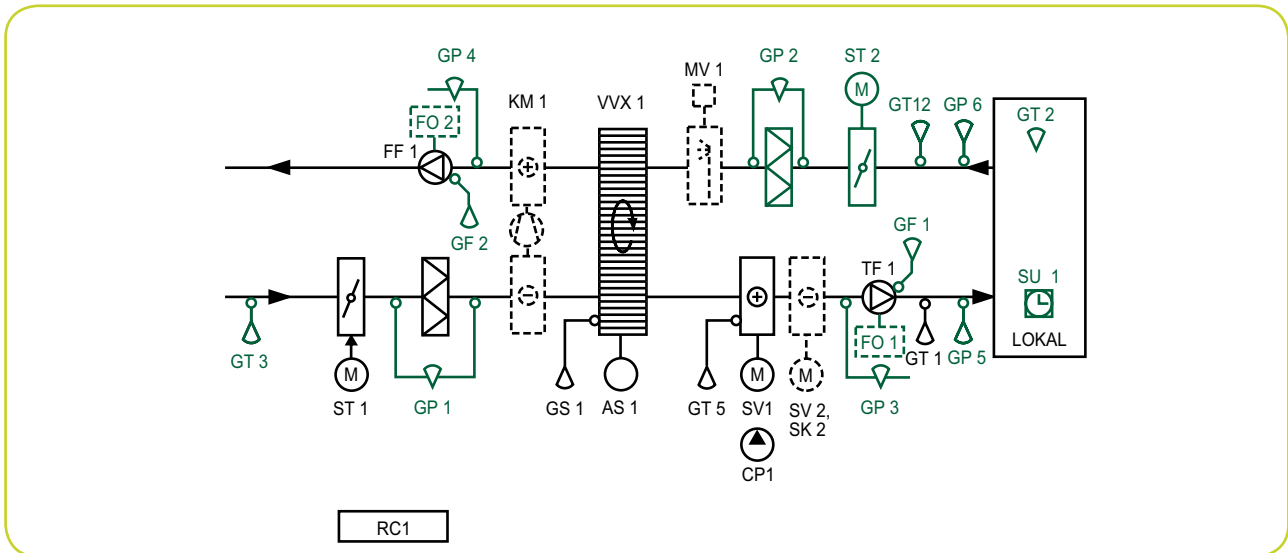

Component list

GP1	Filter monitor, supply air	GT2	Temperature sensor, room
GP2	Filter monitor, extract air	GT3	Temperature sensor, outdoor air
GP3	Flow monitor, supply air	GT12	Temperature sensor, extract air
GP4	Flow monitor, extract air	ST2	Damper actuator
GP5	Pressure sensor, supply air	ST3	Damper actuator, return air
GP6	Pressure sensor, extract air	SU1	Timer

Accessories (dark green in the flow chart)

Room or extract air control

Room or extract air temperature is maintained by controlling the supply air temperature in a cascade limited to a min. and max. value.

Pressure control, fans

Pressure sensors GP5/GP6 maintain the air pressure in the ducts. Frequency converters FO1/FO2 control the speed of TF1/FF1.

Cooling recovery

The heat exchanger is run for 100% recovery at extract air temperatures less than the outdoor temperature.

Outdoor compensation

The desired air temperature setpoint is offset upwards or downwards at high and low outdoor temperatures respectively.

Filter monitor, supply and extract air

Generates an alarm if the pressure drop across each filter exceeds the set value (B alarm).

Flow monitor, supply and extract air

Stops the unit and generates an alarm if the flow is low (B alarm).

Damper actuator

For dampers other than the outdoor air damper.

Fire protection function

Stops the unit in the event of an alarm (A alarm).

Night purging

Starts the unit at night to cool the premises using cold outdoor air. Outdoor sensor for facade mounting.

Night heating

The unit starts automatically at night to heat the premises if the temperature inside is low.

Prolonged operation

Prolonged operation via a timer or external push button with a time set on the panel.

Shunts

Shunt with pilot valve and pump group for the air heater or air cooler for heating water and cooling water.

Flow charts

Supply air unit and extract air units with a rotary heat exchanger

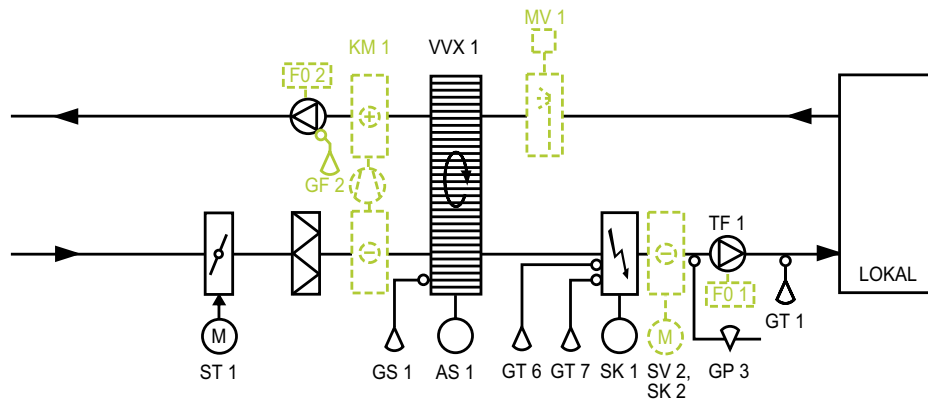

Component list

AS1	Speed controller heat exchanger	KM1	Cooler
FF1	Extract air fan	MV1	Solenoid valve
FO1/FO2	Frequency converter	RC1	Control unit
GF1	Flow sensor, supply air	SK1	Stepping switch or thyristor
GF2	Flow sensor, extract air	ST1	Damper actuator, outdoor air
GP3	Flow monitor, supply air flow	SV1	Valve actuator, heating water
GS1	Rotation monitor sensor	SV2/SK2	Valve actuator cooling/stepping switch, cooling
GT1	Temperature sensor, supply air	TF1	Tilluftsfläkt
GT6	Thermal overload protection, automatic	VWX1	Roterande värmeväxlare
GT7	Thermal overload protection, manual		

Function

TF1/FF1 are started and stopped by the timer built-into RC1. Mode switches along with operation and alarm indication are contained in the operator panel. The extract air fan starts before the supply air fan. Damper actuator ST1 opens before TF1 starts and closes when the fans stop.

Temperature control

The temperature sensor GT1 maintains the desired supply air temperature using RC1 that controls the heat exchanger and electric air heater in sequence. If there is a heat demand the AS1 speed controller increases the speed of the rotor and stepping switch/thyristor SK1 are tied in. If there is a cooling demand SK1 is disconnected and AS1 slows the speed of the rotor.

Air heater, electric

The air heater is interlocked by TF1 and fan monitor GP3. When the unit is stopped by a switch, timer or thermal overload protection, the electric heater is disconnected immediately while the fans continue to run for a set time to cool the unit.

Alarm

Thermal overload protection (B alarm), motor protection fan, supply and extract air (B alarm), rotation monitor VVX (B alarm). Summation alarm to terminal block

Control panel

- Climatix 600
- Xenta 300

Options (light green in the flow chart)

Air cooler, cooling water

The air cooler valve actuator SV2 is controlled in sequence with the heat exchanger and electric heater.

Air cooler, evaporated refrigerant

Stepping switch SK2 switches on the air cooler for the evaporated refrigerant in one or more stages using a stepping or binary switch, in sequence with the heat exchanger and air heater.

Cooler

When the room/extract air temperature exceeds the set value RC1 transmits a signal to air cooler KM1 which switches on one or more stages.

Indirect evaporative cooling

When the outdoor temperature exceeds the set value the rotor is started at maximum speed and solenoid valve MV1 in the water pipe is opened.

Flow control, fans

Flow sensor GF1/GF2 maintains the flow through each fan. Frequency converters FO1/FO2 control the speed of TF1/FF1.

Flow charts

Supply air unit and extract air units with a rotary heat exchanger

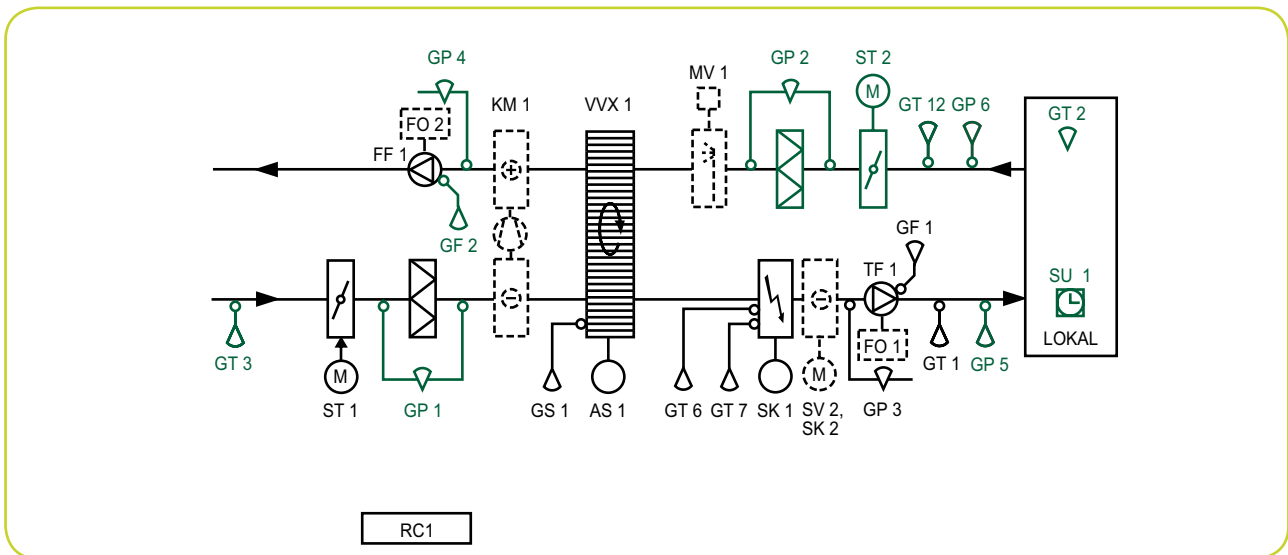

Component list

GP1	Filter monitor, supply air	GT2	Temperature sensor, room
GP2	Filter monitor, extract air	GT3	Temperature sensor, outdoor air
GP3	Flow monitor, supply air	GT12	Temperature sensor, extract air
GP4	Flow monitor, extract air	KM1	Cooler
GP5	Pressure sensor, supply air	ST2	Damper actuator
GP6	Pressure sensor, extract air	ST3	Damper actuator, return air
GP7	Pressure monitor, defrosting	SU1	Timer

Accessories (dark green in the flow chart)

Room or extract air control

Room or extract air temperature is maintained by controlling the supply air temperature in a cascade limited to a min. and max. value.

Pressure control, fans

Pressure sensors GP5/GP6 maintain the air pressure in the ducts. Frequency converters FO1/FO2 control the speed of TF1/FF1.

Cooling recovery

The heat exchanger is run for 100% recovery at extract air temperatures less than the outdoor temperature.

Outdoor compensation

The desired air temperature setpoint is offset upwards or downwards at high and low outdoor temperatures respectively.

Filter monitor, supply and extract air

Generates an alarm if the pressure drop across each filter exceeds the set value (B alarm).

Flow monitor, supply and extract air

Stops the unit and generates an alarm if the flow is low (B alarm).

Damper actuator

For dampers other than the outdoor air damper.

Fire protection function

Stops the unit in the event of an alarm (A alarm).

Night purging

Starts the unit at night to cool the premises using cold outdoor air. Outdoor sensor for facade mounting.

Night heating

The unit starts automatically at night to heat the premises if the temperature inside is low.

Prolonged operation

Prolonged operation via a timer or external push button with a time set on the panel.

Shunts

Shunt with pilot valve and pump group for cooling water for the air cooler.

Flow charts

Supply air unit and extract air units with a plate heat exchanger

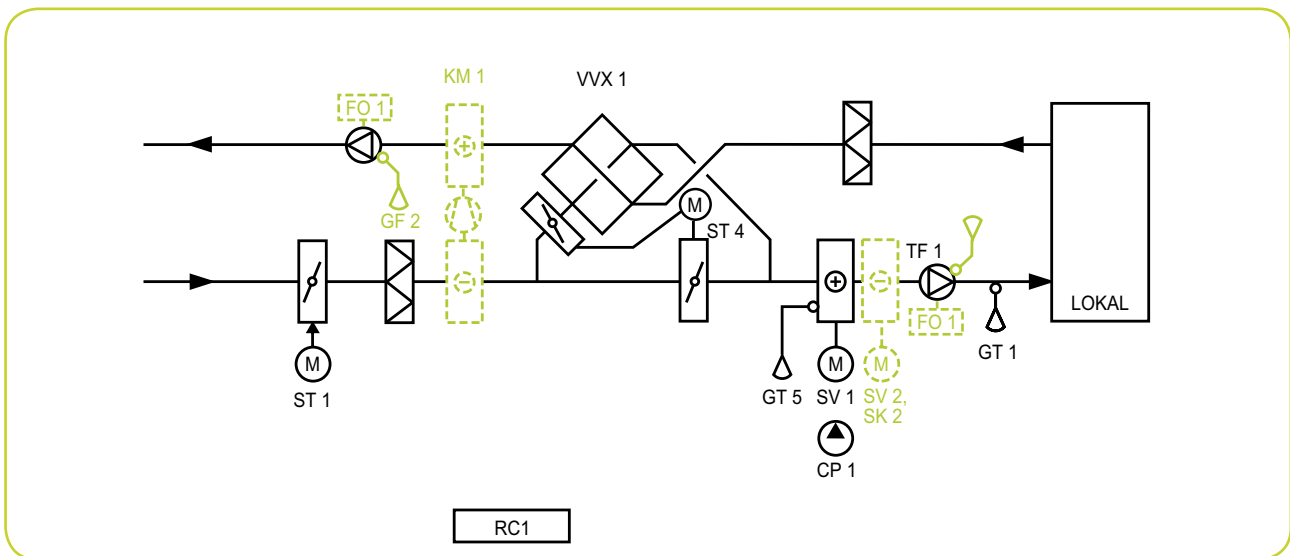

Component list

CP1	Circulation pump, heating water	MV1	Solenoid valve
FF1	Extract air fan	RC1	Control unit
FO1/FO2	Frequency converter	ST1	Damper actuator, outdoor air
GF1	Flow sensor, supply air	ST4	Damper actuator, heat exchanger
GF2	Flow sensor, extract air	SV1	Valve actuator, heating water
GT1	Temperature sensor, supply air	SV2/SK2	Valve actuator cooling/stepping switch, cooling
GT5	Frost protection sensor, air heater	TF1	Supply air fan
KM1	Cooler	VWX1	Plate heat exchanger

Function

TF1/FF1 are started and stopped by the timer built-into RC1. Mode switches along with operation and alarm indication are contained in the operator panel. The extract air fan starts before the supply air fan. Damper actuator ST1 opens before TF1 starts and closes when the fans stop.

Temperature control

The temperature sensor GT1 maintains the desired supply air temperature using RC1 that controls the heat exchanger and air heater in sequence. If there is a heat demand the ST4 bypass damper closes and valve actuator SV1 opens. If there is a cooling demand SV1 closes and ST4 opens.

Air heater, heating water

If there is a risk of frost in the air heater, the frost protection sensor GT5 makes valve actuator SV1 open, after that the unit is stopped. When the unit is stopped, GT5 maintains the return water temperature at approx. 25 °C.

Alarm

Frost protection (A alarm), motor protection fan, supply and extract air (B alarm). Summation alarm to terminal block.

Control panel

- Climatix 600
- Xenta 300

Options (light green in the flow chart)

Air cooler, cooling water

The air cooler valve actuator SV2 is controlled in sequence with the heat exchanger and air heater.

Air cooler, evaporated refrigerant

Stepping switch SK2 switches on the air cooler for the evaporated refrigerant in one or more stages using a stepping or binary switch, in sequence with the heat exchanger and air heater.

Cooler

When the room/extract air temperature exceeds the set value RC1 transmits a signal to air cooler KM1 which switches on one or more stages.

Flow control, fans

Flow sensor GF1/GF2 maintains the flow through each fan. Frequency converters FO1/FO2 control the speed of TF1/FF1.

Flow charts

Supply air unit and extract air units with a plate heat exchanger

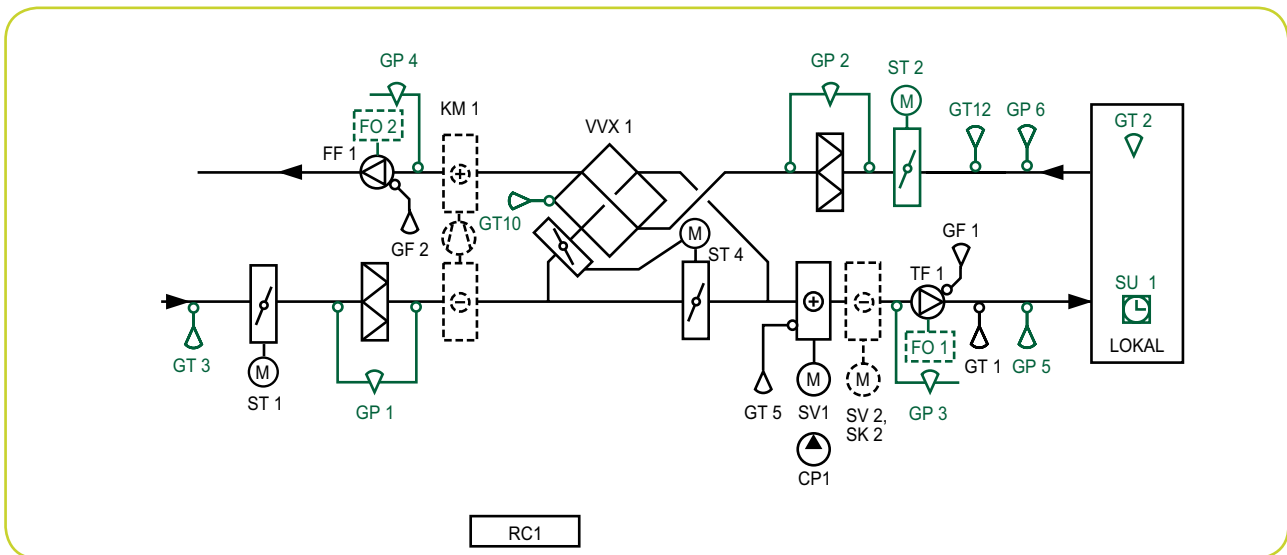

Component list

GP1	Filter monitor, supply air	GT2	Temperature sensor, room
GP2	Filter monitor, extract air	GT3	Temperature sensor, outdoor air
GP3	Flow monitor, supply air	GT12	Temperature sensor, extract air
GP4	Flow monitor, extract air	KM1	Cooler
GP5	Pressure sensor, supply air	ST2	Damper actuator
GP6	Pressure sensor, extract air	ST3	Damper actuator, return air
GP7	Pressure monitor, defrosting	SU1	Timer

Accessories (dark green in the flow chart)

Room or extract air control

Room or extract air temperature is maintained by controlling the supply air temperature in a cascade, limited to a min. and max. value.

Pressure control, fans

Pressure sensors GP5/GP6 maintain the air pressure in the ducts. Frequency converters FO1/FO2 control the speed of TF1/FF1.

Cooling recovery

The heat exchanger is run for 100% recovery at extract air temperatures less than the outdoor temperature.

Outdoor compensation

The desired air temperature setpoint is offset upwards or downwards at high and low outdoor temperatures respectively.

Defrosting

- Section defrosting is activated at outdoor temperatures below $-7\text{ }^{\circ}\text{C}$. The heat exchanger is defrosted continuously by closing the bypass damper and then closing the recirculation dampers one at a time for 15 minutes in order to defrost by section.
- Frosting is avoided by limiting the temperature in the cold corner to $+2\text{ }^{\circ}\text{C}$, by reducing the heat exchanger efficiency, i.e. progressively opening the bypass damper.

Filter monitor, supply and extract air

Generates an alarm if the pressure drop across each filter exceeds the set value (B alarm).

Flow monitor, supply and extract air

Stops the unit and generates an alarm if the flow is low (B alarm).

Damper actuator

For dampers other than the outdoor air damper.

Fire protection function

Stops the unit in the event of an alarm (A alarm).

Night purging

Starts the unit at night to cool the premises using cold outdoor air. Outdoor sensor for facade mounting.

Night heating

The unit starts automatically at night to heat the premises if the temperature inside is low.

Prolonged operation

Prolonged operation via a timer or external push button with a time set on the panel.

Shunts

Shunt with pilot valve and pump group for the air heater or air cooler for heating water and cooling water.

Flow charts

Supply air unit and extract air units with a plate heat exchanger

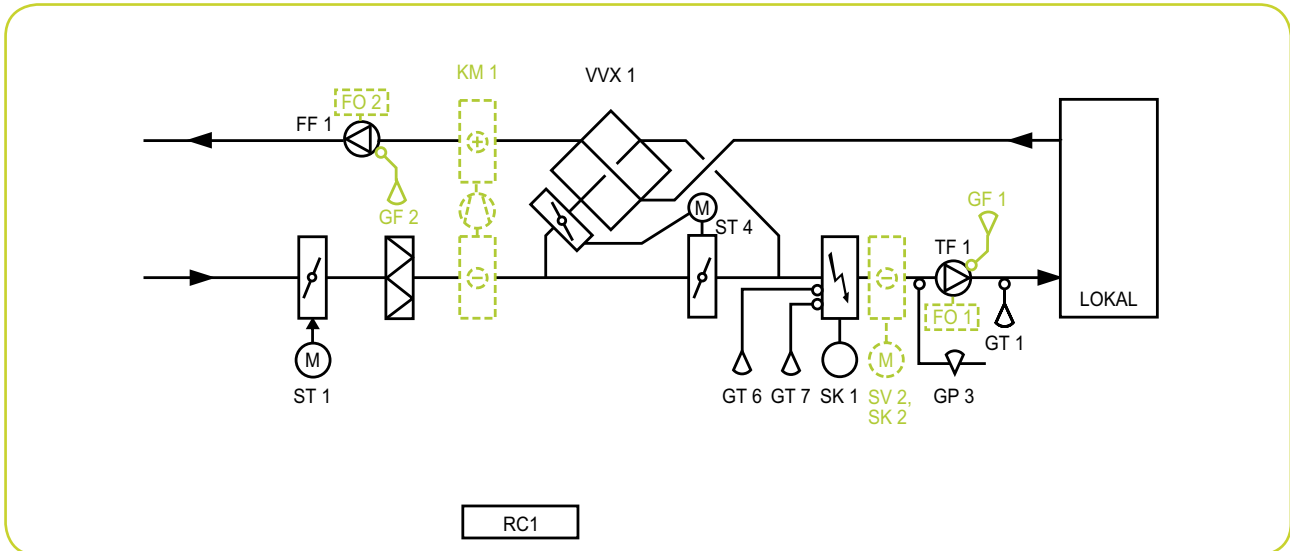

Component list

FF1	Extract air fan	KM1	Cooler
FO1/FO2	Frequency converter	RC1	Control unit
GF1	Flow sensor, supply air	SK1	Stepping switch or thyristor
GF2	Flow sensor, extract air	ST1	Damper actuator, outdoor air
GP3	Flow monitor, supply air	ST4	Damper actuator, heat exchanger
GT1	Temperature sensor, supply air	SV2/SK2	Valve actuator cooling/stepping switch, cooling
GT6	Thermal overload protection, automatic	TF1	Supply air fan
GT7	Thermal overload protection, manual	VWX1	Plate heat exchanger

Function

TF1/FF1 are started and stopped by the timer built into RC1. Mode switches along with operation and alarm indication are contained in the operator panel. The extract air fan starts before the supply air fan. Damper actuator ST1 opens before TF1 starts and closes when the fans stop.

Temperature control

The temperature sensor GT1 maintains the desired supply air temperature using RC1 that controls the heat exchanger and electric air heater in sequence. If there is a heat demand bypass damper ST4 closes and stepping switch/thyristor SK1 is tied in. If there is a cooling demand SK1 is disconnected and ST4 opens.

Air heater, electric

The air heater is interlocked by TF1 and fan monitor GP3. When the unit is stopped by a switch, timer or thermal overload protection, the electric heater is disconnected immediately while the fans continue to run for a set time to cool the unit.

Alarm

Thermal overload protection (B alarm), motor protection fan, supply and extract air (B alarm). Summation alarm to terminal block.

Control panel

- Climatix 600
- Xenta 300

Options (light green in the flow chart)

Air cooler, cooling water

The air cooler valve actuator SV2 is controlled in sequence with the heat exchanger and electric air heater.

Air cooler, evaporated refrigerant

Stepping switch SK2 switches on the air cooler for the evaporated refrigerant in one or more stages using a stepping or binary switch, in sequence with the heat exchanger and air heater.

Cooler

When the room/extract air temperature exceeds the set value RC1 transmits a signal to air cooler KM1 which switches on one or more stages.

Flow control, fans

Flow sensor GF1/GF2 maintains the flow through each fan. Frequency converters FO1/FO2 control the speed of TF1/FF1.

Flow charts

Supply air unit and extract air units with a plate heat exchanger

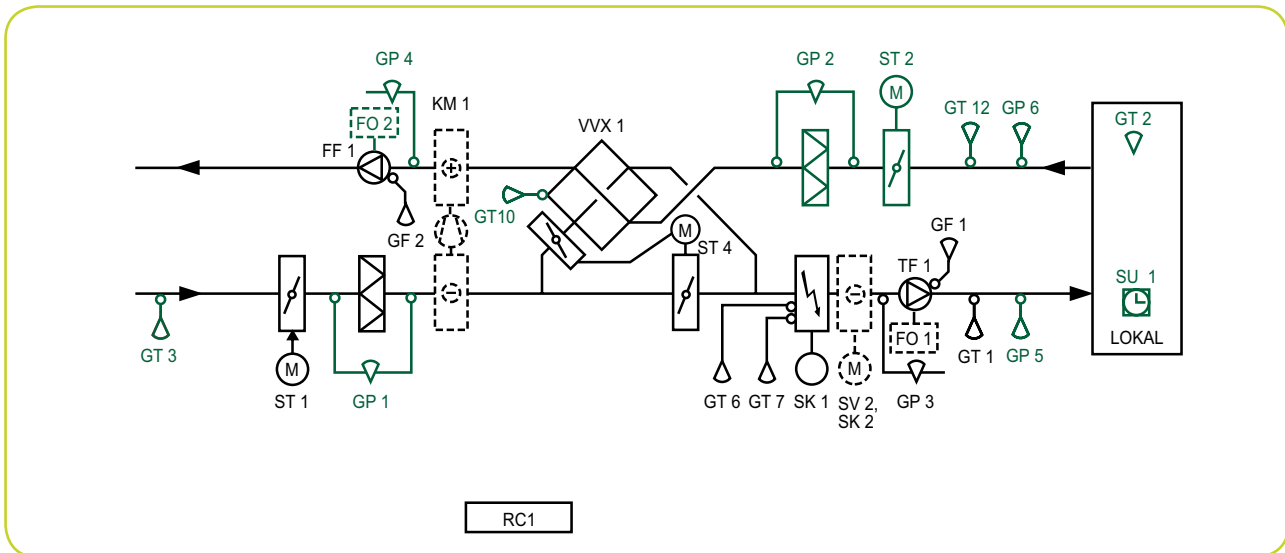

Component list

GP1	Filter monitor, supply air	GT3	Temperature sensor, outdoor air
GP2	Filter monitor, extract air	GT10	Temperature sensor, cold corner
GP4	Flow monitor, extract air	GT12	Temperature sensor, extract air
GP5	Pressure sensor, supply air	ST2	Damper actuator, extract air/exhaust air
GP6	Pressure sensor, extract air	ST3	Damper actuator, return air
GT2	Temperature sensor, room	SU1	Timer

Accessories (dark green in the flow chart)

Room or extract air control

Room or extract air temperature is maintained by controlling the supply air temperature in a cascade, limited to a min. and max. value.

Pressure control, fans

Pressure sensors GP5/GP6 maintain the air pressure in the ducts. Frequency converters FO1/FO2 control the speed of TF1/FF1.

Cooling recovery

The heat exchanger is run for 100% recovery at extract air temperatures less than the outdoor temperature.

Outdoor compensation

The desired air temperature setpoint is offset upwards or downwards at high and low outdoor temperatures respectively.

Defrosting

1. Section defrosting is activated at outdoor temperatures below -7°C . The heat exchanger is defrosted continuously by closing the bypass damper and then closing the recirculation dampers one at a time for 15 minutes in order to defrost by section.

2. Frosting is avoided by limiting the temperature in the cold corner to $+2^{\circ}\text{C}$, by reducing the heat exchanger efficiency, i.e. progressively opening the bypass damper.

Filter monitor, supply and extract air

Generates an alarm if the pressure drop across each filter exceeds the set value (B alarm).

Flow monitor, supply and extract air

Stops the unit and generates an alarm if the flow is low (B alarm).

Damper actuator

For dampers other than the outdoor air damper.

Fire protection function

Stops the unit in the event of an alarm (A alarm).

Night purging

Starts the unit at night to cool the premises using cold outdoor air. Outdoor sensor for facade mounting.

Night heating

The unit starts automatically at night to heat the premises if the temperature inside is low.

Prolonged operation

Prolonged operation via a timer or external push button with a time set on the panel.

Shunts

Shunt with pilot valve and pump group for cooling water for the air cooler.

Flow charts

Supply air unit and extract air units with a liquid-coupled heat exchanger

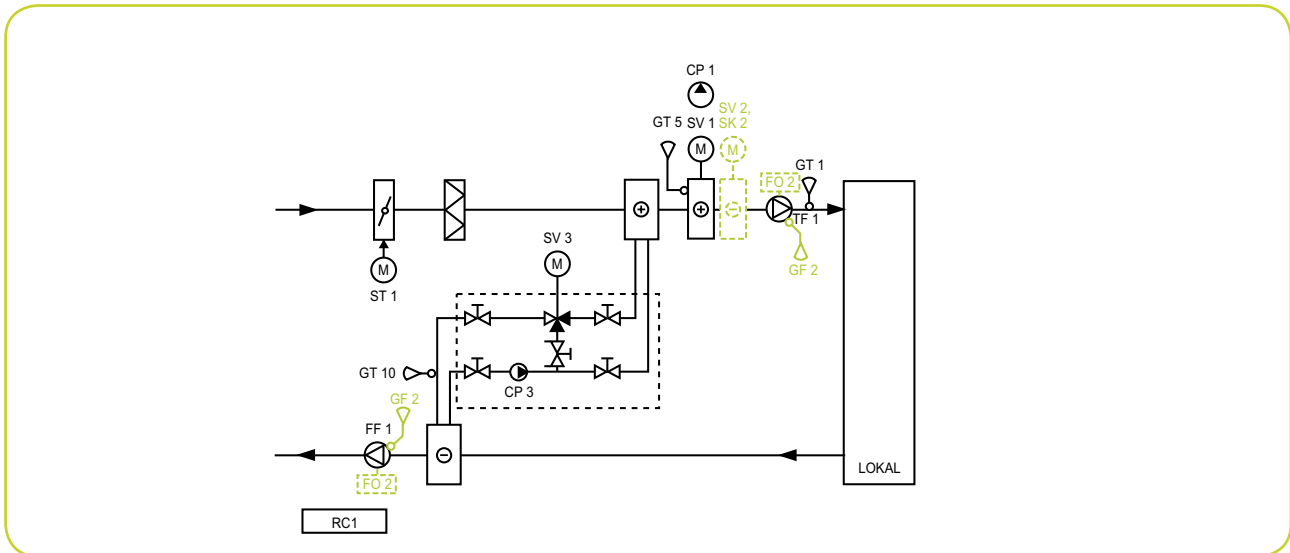

Component list

CP1	Circulation pump, heating water	GT10	Frost monitor, heat exchanger
CP3	Circulation pump, recovery water	RC1	Control unit
FF1	Extract air fan	ST1	Damper actuator, outdoor air
FO1/FO2	Frequency converter	SV1	Valve actuator, heating water
GF1	Flow sensor, supply air	SV3	Valve actuator, recovery water
GF2	Flow sensor, extract air	SV2/SK2 V	Valve actuator cooling/stepping switch, cooling
GT1	Temperature sensor, supply air	TF1	Supply air fan
GT5	Frost protection sensor, air heater		

Function

TF1/FF1 are started and stopped by the timer built-into RC1. Mode switches along with operation and alarm indication are contained in the operator panel. The extract air fan starts before the supply air fan. Damper actuator ST1 opens before TF1 starts and closes when the fans stop.

Temperature control

The temperature sensor GT1 maintains the desired supply air temperature using RC1 that controls the heat exchanger and air heater in sequence. If there is a heat demand valve actuator SV3 opens first and then valve actuator SV1 opens. If there is a cooling demand SV1 closes first and then ST4 closes.

Air heater, heating water

If there is a risk of frost in the air heater, the frost protection sensor GT5 makes valve actuator SV1 open, after that the unit is stopped. When the unit is stopped, GT5 maintains the return water temperature at approx. 25 °C.

Alarm

Frost protection (A alarm), motor protection fan, supply and extract air (B alarm). Summation alarm to terminal block.

Control panel

- Climatix 600
- Xenta 300

Options (light green in the flow chart)

Air cooler, cooling water

The air cooler valve actuator SV2 is controlled in sequence with the heat exchanger and air heater.

Air cooler, evaporated refrigerant

Stepping switch SK2 switches on the air cooler for the evaporated refrigerant in one or more stages using a stepping or binary switch, in sequence with the heat exchanger and air heater.

Flow control, fans

Flow sensor GF1/GF2 maintains the flow through each fan. Frequency converters FO1/FO2 control the speed of TF1/FF1.

Flow charts

Supply air and extract air units with a liquid-coupled heat exchanger

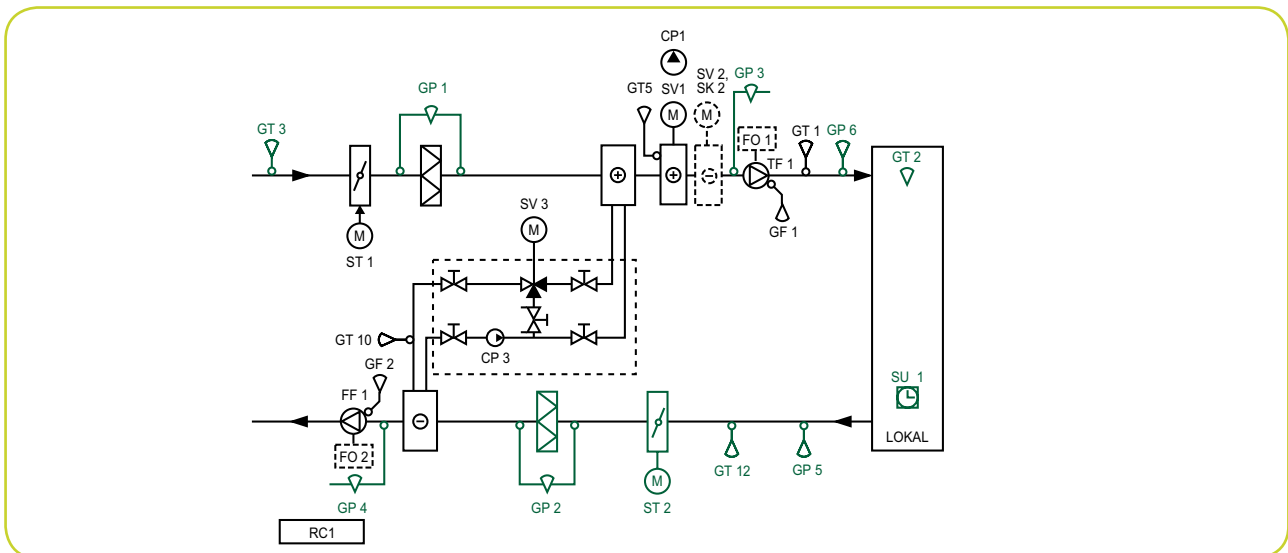

Component list

GP1	Filter monitor, supply air	GT2	Temperature sensor, room
GP2	Filter monitor, extract air	GT3	Temperature sensor, outdoor air
GP3	Flow monitor, supply air	GT12	Temperature sensor, extract air
GP4	Flow monitor, extract air	ST2	Damper actuator
GP5	Pressure sensor, supply air	ST3	Damper actuator, return air
GP6	Pressure sensor, extract air	SU1	Timer

Accessories (dark green in the flow chart)

Room or extract air control

Room or extract air temperature is maintained by controlling the supply air temperature in a cascade, limited to a min. and max. value.

Pressure control, fans

Pressure sensors GP5/GP6 maintain the air pressure in the ducts. Frequency converters FO1/FO2 control the speed of TF1/FF1.

Cooling recovery

The heat exchanger is run for 100% recovery at extract air temperatures less than the outdoor temperature.

Outdoor compensation

The desired air temperature setpoint is offset upwards or downwards at high and low outdoor temperatures respectively.

Defrosting

Frosting is avoided by ensuring that the temperature in the inlet line to the extract air heat exchanger does not drop below the set value, by reducing the heat exchanger efficiency, i.e. progressively closing the pilot valve.

Filter monitor, supply and extract air

Generates an alarm if the pressure drop across each filter exceeds the set value (B alarm).

Filter monitor, supply and extract air

Stops the unit and generates an alarm if the flow is low (B alarm).

Damper actuator

For dampers other than the outdoor air damper.

Fire protection function

Stops the unit in the event of an alarm (A alarm).

Night purging

Starts the unit at night to cool the premises using cold outdoor air. Outdoor sensor for facade mounting.

Night heating

The unit starts automatically at night to heat the premises if the temperature inside is low.

Prolonged operation

Prolonged operation via a timer or external push button with a time set on the panel.

Shunts

Shunt with pilot valve and pump group for the air heater or air cooler for heating water and cooling water.

Flow charts

Supply air and extract air units with a liquid-coupled heat exchanger

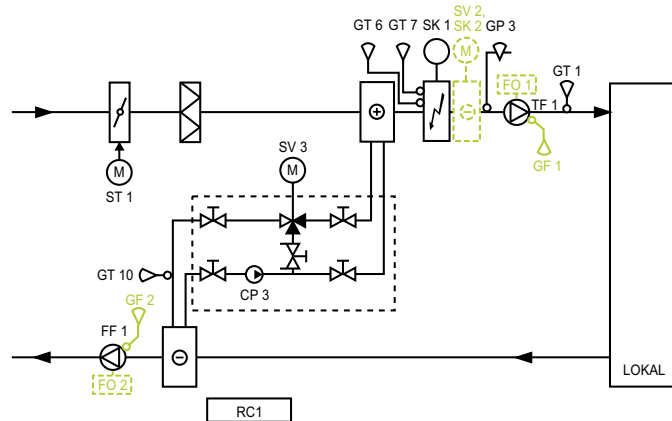

Component list

CP3	Circulation pump, recovery water	GT10	Frost monitor, heat exchanger
FF1	Extract air fan	RC1	Control unit
FO1/FO2	Frequency converter	SK1	Stepping switch or thyristor
GF1	Flow sensor, supply air	ST1	Damper actuator, outdoor air
GF2	Flow sensor, extract air	TF1	Supply air fan
GP3	Flow monitor, supply air	SV2/SK2	Valve actuator cooling/stepping switch, cooling
GT1	Temperature sensor, supply air	SV3	Valve actuator, recovery water
GT6	Thermal overload protection, automatic		
GT7	Thermal overload protection, manual		

Function

TF1/FF1 are started and stopped by the timer built-into RC1. Mode switches along with operation and alarm indication are contained in the operator panel. The extract air fan starts before the supply air fan. Damper actuator ST1 opens before TF1 starts and closes when the fans stop.

Temperature control

The temperature sensor GT1 maintains the desired supply air temperature using RC1 that controls the heat exchanger and electric air heater in sequence. If there is a heat demand valve actuator SV3 opens and stepping switch/thyristor SK1 is tied in. If there is a cooling demand SK1 is disconnected and ST3 closes.

Air heater, electric

The air heater is interlocked by TF1 and fan monitor GP3. When the unit is stopped by a switch, timer or thermal overload protection, the electric heater is disconnected immediately while the fans continue to run for a set time to cool the unit.

Alarm

Thermal overload protection (B alarm), motor protection fan, supply and extract air (B alarm). Summation alarm to terminal block.

Control panel

- Climatix 600
- Xenta 300

Options (light green in the flow chart)

Air cooler, cooling water

The air cooler valve actuator SV2 is controlled in sequence with the heat exchanger and electric heater.

Air cooler, evaporated refrigerant

Stepping switch SK2 switches on the air cooler for the evaporated refrigerant in one or more stages using a stepping or binary switch, in sequence with the heat exchanger and air heater.

Flow control, fans

Flow sensor GF1/GF2 maintains the flow through each fan. Frequency converters FO1/FO2 control the speed of TF1/FF1.

Flow charts

Supply air and extract air units with a liquid-coupled heat exchanger

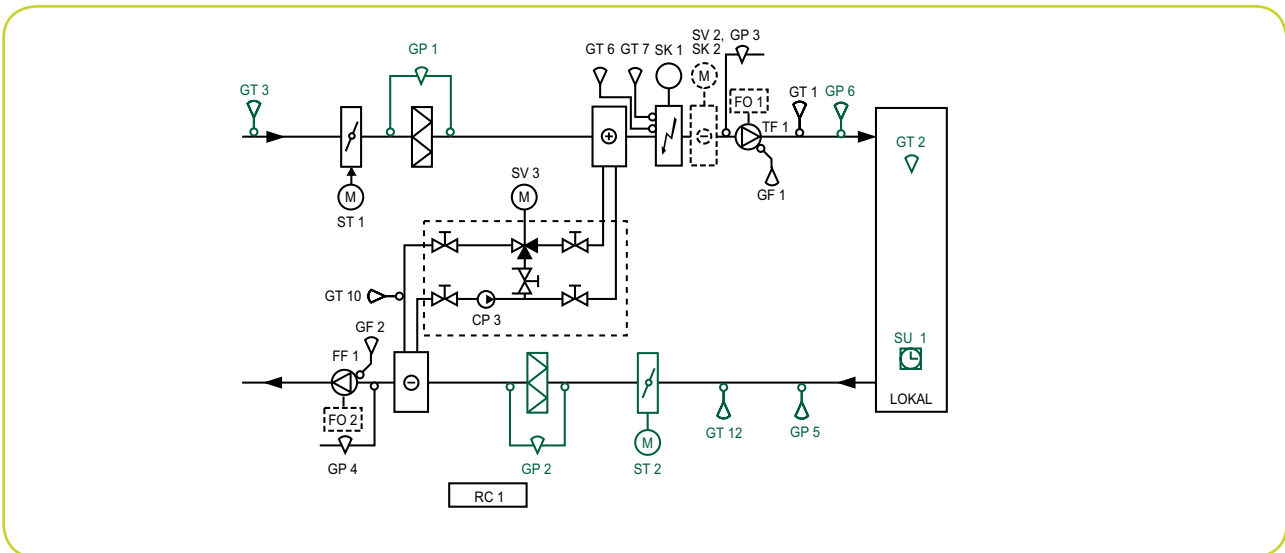

Component list

GP1	Filter monitor, supply air	GT2	Temperature sensor, room
GP2	Filter monitor, extract air	GT3	Temperature sensor, outdoor air
GP3	Flow monitor, supply air	GT12	Temperature sensor, extract air
GP4	Flow monitor, extract air	ST2	Damper actuator
GP5	Pressure sensor, supply air	ST3	Damper actuator, return air
GP6	Pressure sensor, extract air	SU1	Timer

Accessories (dark green in the flow chart)

Room or extract air control

Room or extract air temperature is maintained by controlling the supply air temperature in a cascade, limited to a min. and max. value.

Pressure control, fans

Pressure sensors GP5/GP6 maintain the air pressure in the ducts. Frequency converters FO1/FO2 control the speed of TF1/FF1.

Cooling recovery

The heat exchanger is run for 100% recovery at extract air temperatures less than the outdoor temperature.

Outdoor compensation

The desired air temperature setpoint is offset upwards or downwards at high and low outdoor temperatures respectively.

Defrosting

Frosting is avoided by ensuring that the temperature in the inlet line to the extract air heat exchanger does not drop below the set value, by reducing the heat exchanger efficiency, i.e. progressively closing the pilot valve.

Filter monitor, supply and extract air

Generates an alarm if the pressure drop across each filter exceeds the set value (B alarm).

Flow monitor, supply and extract air

Stops the unit and generates an alarm if the flow is low (B alarm).

Damper actuator

For dampers other than the outdoor air damper.

Fire protection function

Stops the unit in the event of an alarm (A alarm).

Night purging

Starts the unit at night to cool the premises using cold outdoor air. Outdoor sensor for facade mounting.

Night heating

The unit starts automatically at night to heat the premises if the temperature inside is low.

Prolonged operation

Prolonged operation via a timer or external push button with a time set on the panel.

Shunts

Shunt with pilot valve and pump group for cooling water for the air cooler.

Accessories

Casing

EQAZ-01 Inspection window

Double window in Plexiglas.



EQAZ -02 Lifting device

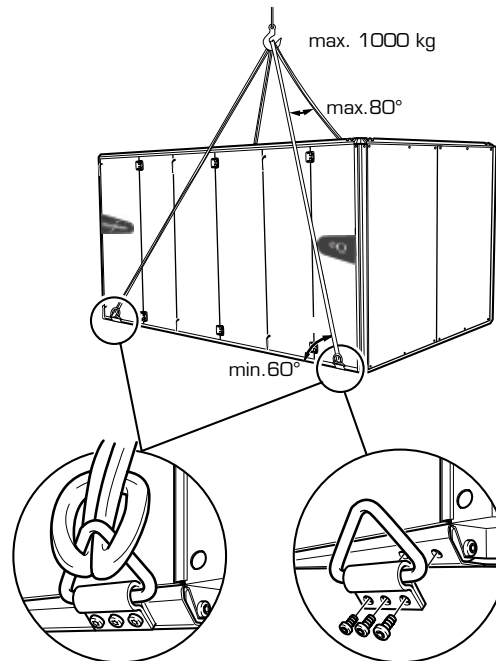

Accessories

Casing

EQAZ-04 Base frame

A very stable and torsionally resistant frame for the entire unit, one or more blocks. The base frame is secured to the frame profile of the unit with fixing plates. The length and width of the base frame must be adapted to the size of the unit and the combination of functional parts.

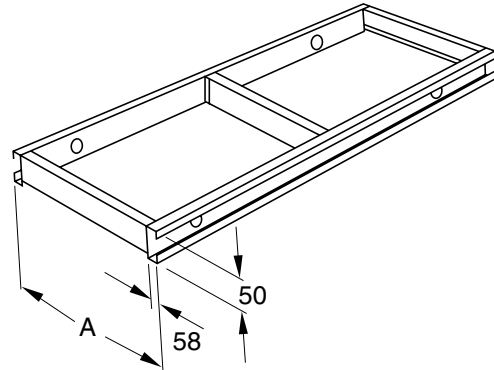

Unit size bbb	Width A	Unit size bbb	Width A
005,009	774	032	1774
008,014,020	1074	041,054,068	1974
011	1174	050,063,079	2274
018,027,036	1374	072,090	2574
023,045,056	1674		

EQAZ-05 Adjustable feet (set)

The feet can adjust the height of the unit above the floor and can compensate for any unevenness in the floor. Available in plate or plastic.

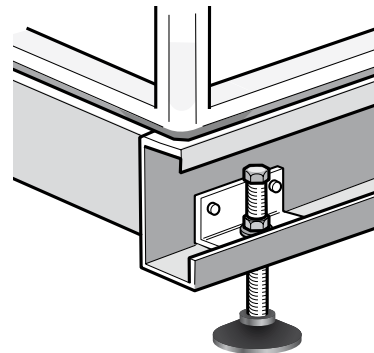

C = 2
 Sheet steel foot
 Height adjustment:
 15 mm min. – 80 mm max.
 Washer: ø 92 mm.
 Only with EQAZ-04.

Accessories

Casing

EQAZ -06 Lifting tube, set

EQAZ -07 Lifting spreader, set

These are used in combination with base frame EQAZ-04.

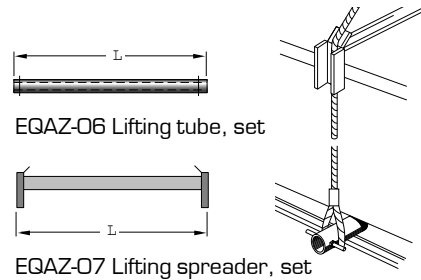

Unit size bbb	Length L	Unit size bbb	Length L
005,009	1000	032	2100
008,014,020	1300	041,054,068	2300
011	1400	050,063,079	2600
018,027,036	1600	072,090	2900
023,045,056	1900		

EQAZ-09 Bulkhead light, IP-54

Internal lighting equipment Available as LED or low-energy bulb. Can be delivered wired to built-in control cabinet.

EQAZ-10 Armature connection

Common switches must be on a fixed panel on the block where the armature and switch occurs. In cases where the fixed panel is missing the switch is delivered unmounted.

EQAZ-16 Joining piece set

For joining units in an L-formed or stacked arrangement.

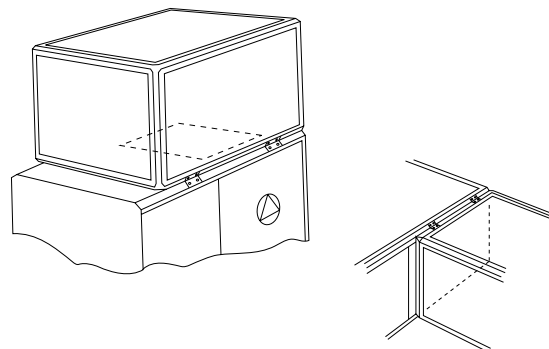

Accessories

Casing



EQAZ-20 Anti-slip protection

For units that allow access
(must be equipped with anti-slip protection).

EQAZ-24 Espagnolette

To facilitate the opening of doors higher than 2000 mm, an espagnolette can connect the handles on the inside of the door.

- EQAZ-25 Flexible connection
- EQAZ-26 Duct connection piece
- EQAZ-27 Counter-flange (d=2)
- EQAZ-28 Protective screen

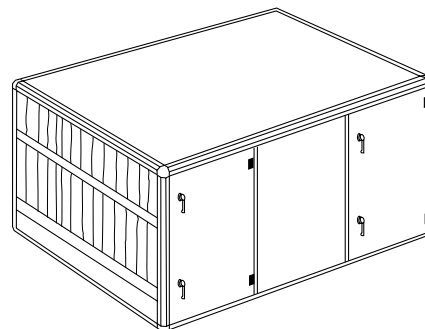
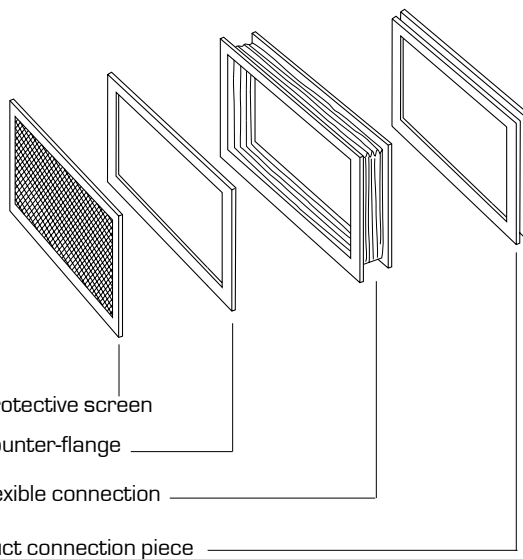

EQAZ-30 Adjustment panels

Adjustment panels are supplied with the unit size 005-023 to create the correct pressure balance across the rotor so that purging air flow will pass in the right direction. The panels should be placed upstream of the extract air filter, if their use is necessary.



Accessories

Casing

EQAZ-60 Combination cover, for wall mounting

The cover is intended to be positioned on a wall for the intake of outdoor air on the bottom edge and blowing out of extract air directly outwards. The cover is manufactured from galvanized sheet steel and is painted with black epoxy paint. Inlet and outlet openings are provided with a secure net to exclude small animals.

EQAZ-60-b	Connection	Outer dimension (W x H x L)	C/C	Weight kg
b=1(005)	2 x \varnothing 400	1000 x 580 x 220	500	15
b=2 (008, 011)	2 x \varnothing 500	1200 x 720 x 300	600	22

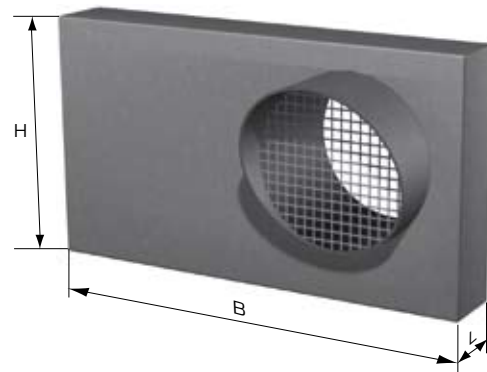

Pressure drop, outdoor air and extract air

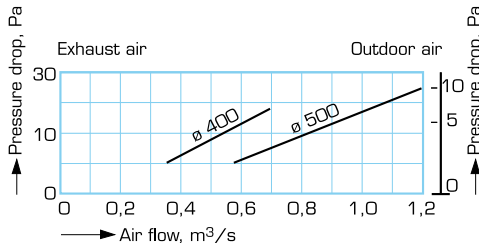

EQAZ-61 Combination cover, ceiling mounting

The cover is intended to be positioned in the roof for the intake of outdoor air on the bottom edge and the blowing out of extract air upwards. The extract air part is equipped with a non-return damper. The outdoor air side is provided with a secure net to exclude small animals. The cover is manufactured from galvanized sheet steel. The cover matches ceiling lead-trough EQAZ-62.

EQAZ-61-b	A	B	C	D	E	F	G	Weight kg
b = 1 (005, 008, 011) 1000 x 500	1050	550	525	1450	850	1000	500	45
b = 2 (011, 018) 1400 x 700	1450	750	675	1950	1150	1400	700	75
b = 3 (023) 1800 x 900	1850	950	750	2400	1400	1800	900	105

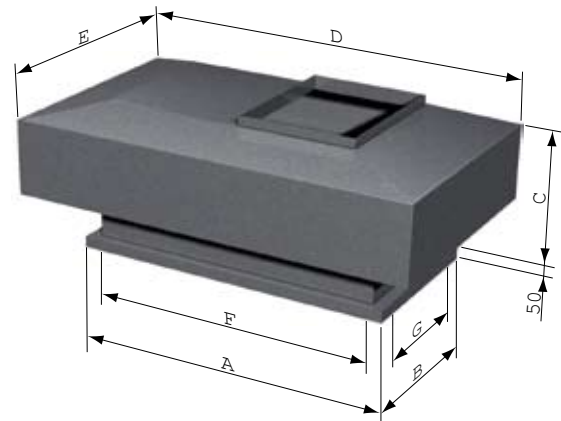

Exhaust air

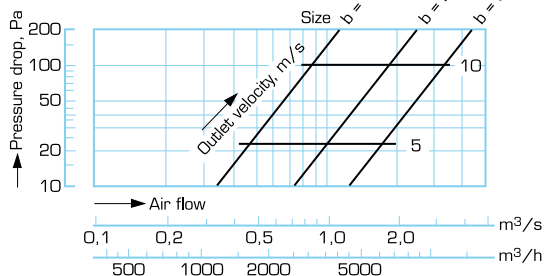

Outdoor air

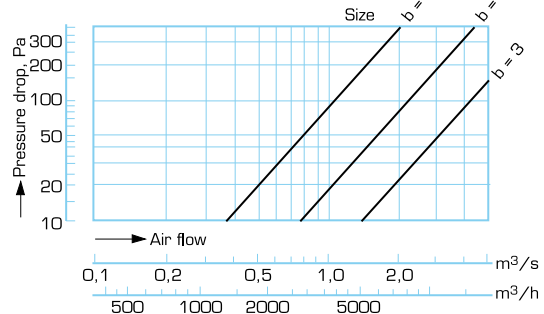

Accessories

Casing

EQAZ-62 Ceiling lead-trough

The ceiling lead-trough is intended for combination cover EQAZ-61. It is insulated with 50 mm mineral wool which is covered with perforated sheet. Provided with angle brackets for attachment to the roof construction.

EQAZ-62-b	Outer dimension (W x H x L)	Duct connection	Hole dimensions	A	Weight kg
bb=1 (005, 008, 011,) 1000x500	1000 x 500 x 800	2 x ø 400	1010 x 510	500	56
bb=2 (011, 018) 1400x700	1400 x 700 x 800	600 x 600	1410 x 710	700	72
bb=3 (023) 1800x900	1800 x 900 x 800	800 x 800	1810 x 910	900	92



EQAZ-63 Stand for vertical position, size 005-008

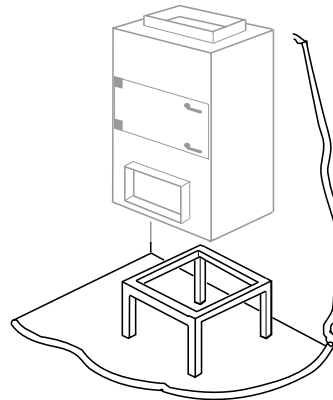

EQAZ-42 Extension legs with adjustable feet, set

Extension legs (not installed) can be cut to desired length. Plastic foot (EQAZ-05) included.

Accessories

Casing



EQWZ-01 Bottom drain

Drainage of casing, hygienic design.



EQWZ-02 Drain trough

Drainage of casing, hygienic design.

Other accessories for the casing:

EQAZ-11 Support beam
 EQAZ-15 Tool kit for eQ casing
 EQAZ-17 Door stop (for doors on pressurized units)

EQAZ-23 Ground cable (eQ PLUS)
 EQAZ-29 Floor grating

Damper

EQAZ-13 Lever actuator

The actuator is used for controlling the intake damper
 c = 1 Wheel (EQAZ-12 max bbb=150, ccc=080)
 c=2 Lever

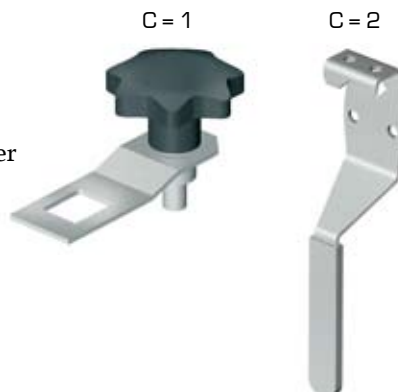

Accessories

Filter

EQPZ-12 Analogue differential pressure gauge for measuring filter pressure drop

b=1 U-tube manometer

Visual reading. Measurement range 0-800 Pa.
Ambient temperature -25 °C to +100 °C.
Supplied separately.

b=2 Differential pressure gauge (Kyttelä type)

Visual reading. Measurement range: 0-300 Pa on an inclined scale and 300-500 Pa on a vertical scale.
Ambient temperature -40 °C to +50 °C.
Supplied separately.

b=3 Sloping tube manometer

Visual reading. Measurement range 0-250 Pa or 0-500 Pa, can be reset to a suitable range.
Ambient temperature -20 °C to +50 °C.
Supplied separately.

b=4 Pressure switch manometer

Visual reading and with breaking contacts.
Measurement range 0-500 Pa or 50-1200 Pa.
Ambient temperature -15 to +50 °C. Supplied separately.

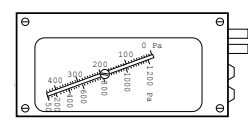
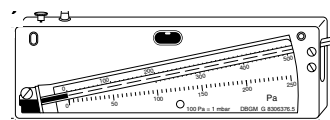
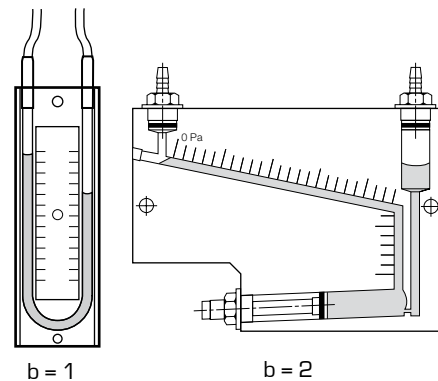

b = 3

b = 4

EQPZ-25 Differential pressure gauge type Dwyer Magnehelic

Pressure range first sensor (b)

- 1 = 0-125 Pa
- 2 = 0-250 Pa
- 3 = 0-500 Pa
- 4 = 0-750 Pa
- 5 = 0-1000 Pa

Pressure range second sensor (c)

- 0 = only one sensor
- 1 = 0-125 Pa
- 2 = 0-250 Pa
- 3 = 0-500 Pa
- 4 = 0-750 Pa
- 5 = 0-1000 Pa

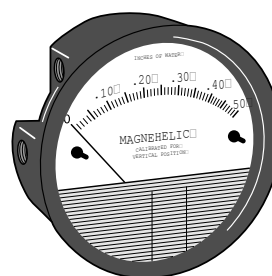

Consists of one or two sensors recessed into the inspection door

Other accessories for the filter:

- EQPZ-02 Filter mat for EQPA, set
- EQPZ-05 Prefilter for EQPB, set
- EQPZ-01 Replacement filter for EQPA, set

- EQPZ-03 Replacement filter for EQPB, set
- EQPZ-06 Replacement filter for EQPK, set (eQ PLUS)
- EQPZ-24 Filter cassettes for EQPF, set (eQ PLUS)

Accessories

Fan

EQLZ -02 Outlet cowl, fan

Variant (c)

- 1 = Outlet cowl (with side outlet)
- 2 = Outlet cowl (radial fan EQLR)
- 3 = Outlet cowl (plenum fan EQLK)

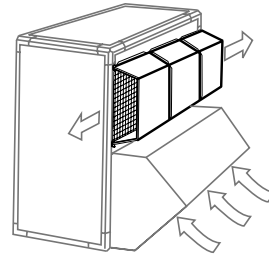

EQLZ-24 Screen protection



EQLZ-25 Telpher beam, EQLZ-29 Telpher

EQLZ-25 Telpher beam
Used in motor replacement, Centrifugal fan
EQLR.
Only for casing with frame.

EQLZ-29 Telpher
Set for EQLZ-25 for unit sizes 068, 079-090

Accessories

Fan

EQLZ-42 Manometer



Other accessories for the fan:

EQLZ-13 Air distributor

EQLZ-15 Inspection cover

EQLZ-16 Drain connection

EQLZ-28 Motor enclosures (eQ PLUS)

EQLZ-36 Outlet guard

EQLZ-37 Inlet guard

EQLZ-48 Cable gland

Humidifier



EQQZ-01 Humidifier replacement

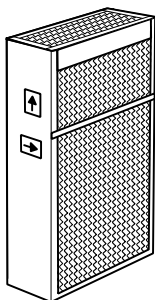

Control equipment

EQAZ-51 Cable trunk, horizontal

EQAZ-52 Cable trunk, vertical

External cable trunk in natural anodized aluminium.

Accessories

Liquid-coupled heat exchanger

EQRZ-05 Heat exchanger package for ECONET®

In most cases some form of supplementary heating or cooling is necessary. Instead of ordering cooling/heat exchanger separately, Fläkt Woods offer a complete heating exchanger package.

Plate heat exchanger

EQRZ-01 Washing tray, with drainage

Extra tray for plate heat exchanger, supply air side. Should be ordered if the unit will be installed in environments with high atmospheric humidity.



Plate heat exchanger and heating/cooling coil

EQAZ-08 Water trap

b = 1 Negative pressure -800 Pa
 b = 2 Positive pressure +3000 Pa.

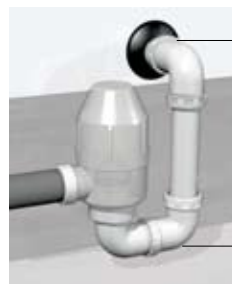

b = 1 Negative pressure -800 Pa



b = 2 Positive pressure +3000 Pa

Accessories

Heating/cooling coil

EQAZ-18 Manual air purging valve with spigot

Supplied separately.



EQAZ-19 Automatic air purging valve with spigot

For max. 115 °C and min. 0 °C, 1.1 MPa (11 atm).
 The valve seat is not damaged by a high water temperature or by water which contains a frost protection fluid.
 The valve can be combined with a freezing monitor.
 Cannot be positioned outdoors.

Supplied separately.



EQAZ-21 Expansions valve

Thermostatic expansion valve for DX-coils.

EQAZ-35 Thermometer
 (dial indicator with sensor bulb)

For positioning in a panel or duct. Supplied separately.

Available in three variants:

bbbb = 5021 = -20 °C to +60 °C A = 400

bbbb = 5022 = -20 °C to +60 °C /
 -4 °F to +140 °F A = 200

bbbb = 5023 = 0 °C to +100 °C A = 200

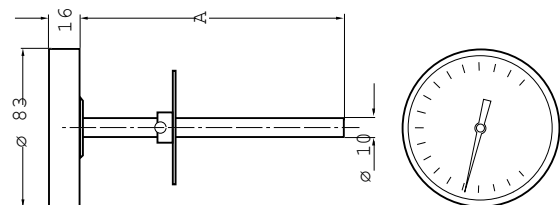

Accessories

EQAZ-40 Flange, for air heater and air cooler

For 1-off pipe connection. With or without counter-flange.

Connection dimension	D	E	G	n
15	95	65	14	4
25	115	85	14	4
40	140	100	18	4
50	165	125	18	4
80	200	160	18	8

Material:

Steel or bronze. Pressure class PN 16.

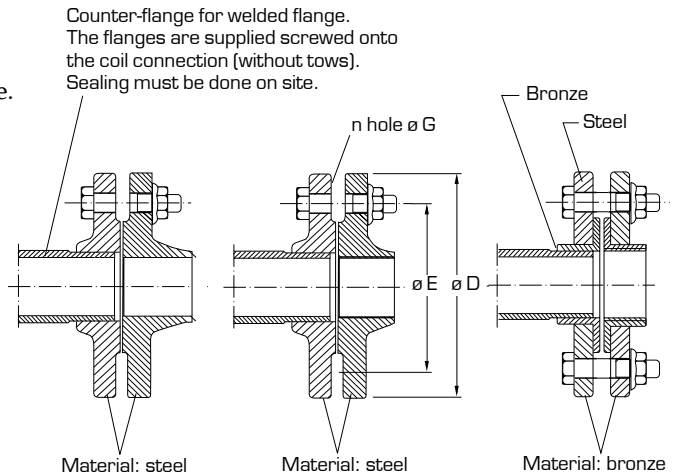

EQTZ-05 Dagger plate

Dagger plate for empty section EQTB in combination with EQH(N,P). Available in stainless steel or galvanized sheet steel.

Other accessories for heating/cooling coil:

EQAZ-14 Fin comb

Cooling unit, COOLER

EQKZ-01 Hot gas by pass

Hot gas by pass is used for softer temperature regulations. More energy is consumed in favour of softer regulations.

Accessories

Outdoor design

EQBZ-01 Roof

Roof made of galvanized or polyester-coated sheet steel for an assembled unit.
The roof is selected having regard for the size and length of the actual unit.

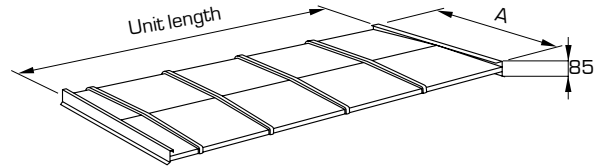

Unit size	Width A	Unit size	Width A
005,009	960	032	1960
008,014,020	1260	041,054,068	2160
011	1360	050,063,079	2460
018,027,036	1560	072,090	2760
023,045,056	1860		

EQBZ-03 Door stop for a door

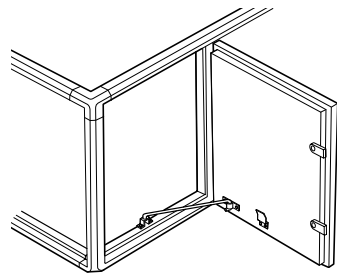

EQBZ-09 Hood, louvered shutter, flaps for outdoor unit

- e = 1 Inlet hood
- e = 2 Louvered shutter (fins in PP)
- e = 3 Flaps

Other out door accessories:

EQBZ-04 Roof connection

For sealing against the upper deck if it is shorter than the lower deck. Supplied ready assembled.

Fan charts

Plenum fan EQLK, EQLT with EC-motor
Description

EQLK-011-2/014-2, EQLT-011-2 7

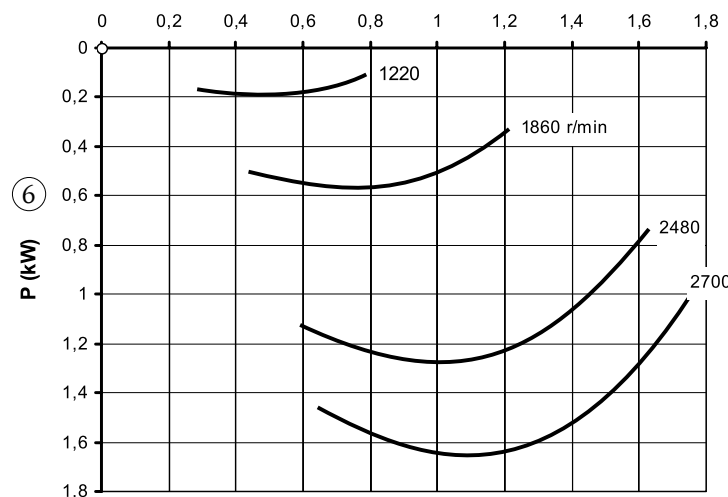
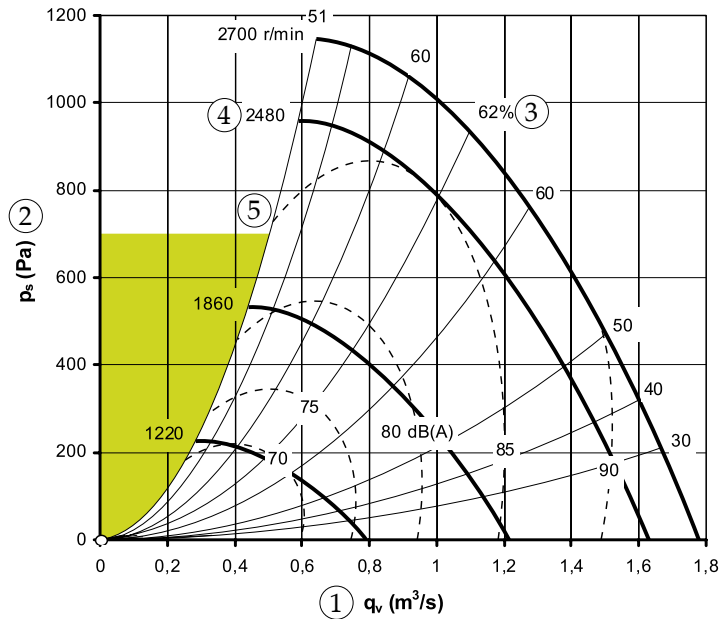

The fan charts give a general view. For more precise information, see product selection tool ACON.

The fan charts on the pages that follow are applicable to a bare fan and to air with a density of 1,2 kg/m³. When the fan is incorporated in a unit section an system loss will arise. This system loss depends on the components placement before the fan. For more precise information about system loss, see product selection tool ACON.

- 1 = Air flow, m³/s (horizontal axis)
- 2 = Static pressure increase, Δp_s Pa (vertical axis)
- 3 = Total efficiency, η %
- 4 = Max. speed of each motor, kW-no. of motor poles
- 5 = Total sound power level, LwA (dB), broken line
- 6 = Power required
- 7 = Unit and fan size
- = When the fan is controlled to operate at a lower speed, the duty point is allowed to come to rest within the coloured field.

For information about system loss, see product selection tool ACON.

Fan charts

Plenum fan EQLK with EC-motor

EQLK-005-2

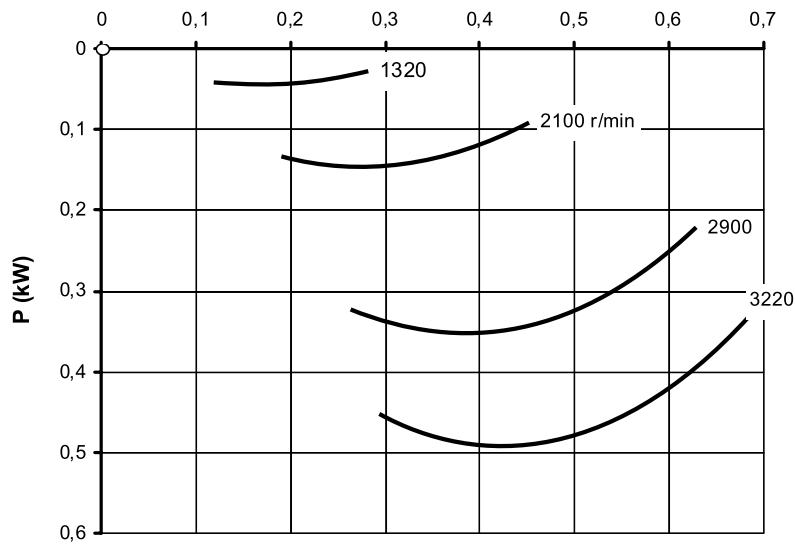
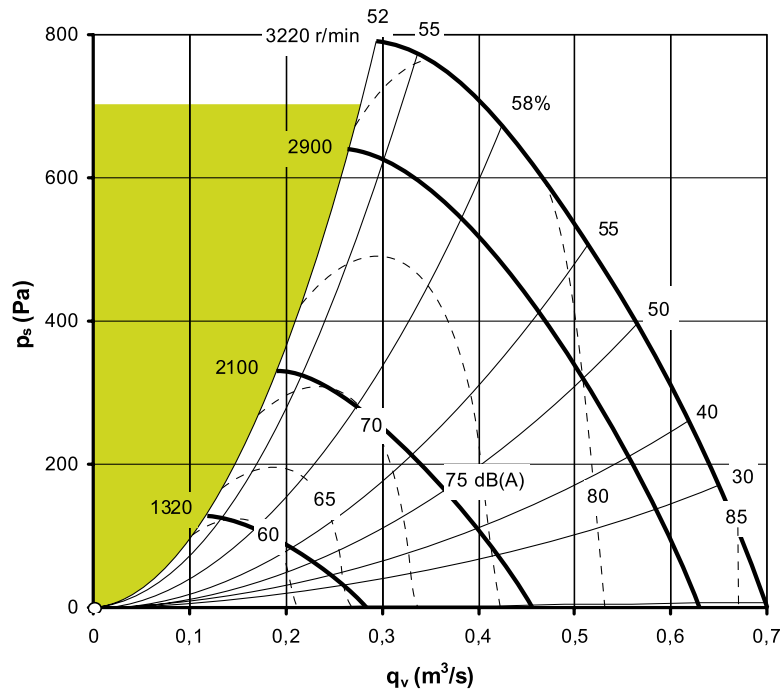

For information about system loss, see product selection tool ACON.

Fan charts

Plenum fan EQLK with EC-motor

Plenum fan EQLT with EC-motor for eQ Top

EQLK-008-2/009-2, EQLT-008-2

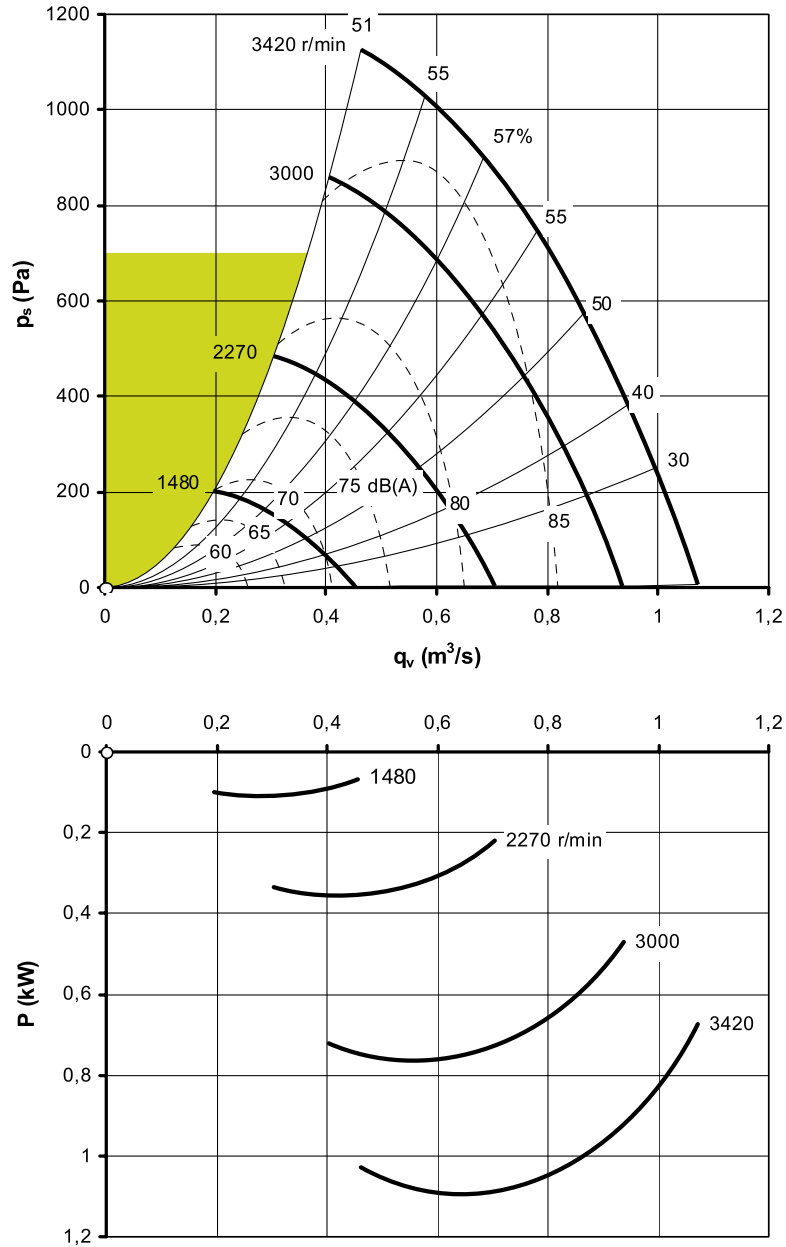

For information about system loss, see product selection tool ACON.

Fan charts

Plenum fan EQLK with EC-motor

Plenum fan EQLT with EC-motor for eQ Top

EQLK-008-3/009-3, EQLT-008-3

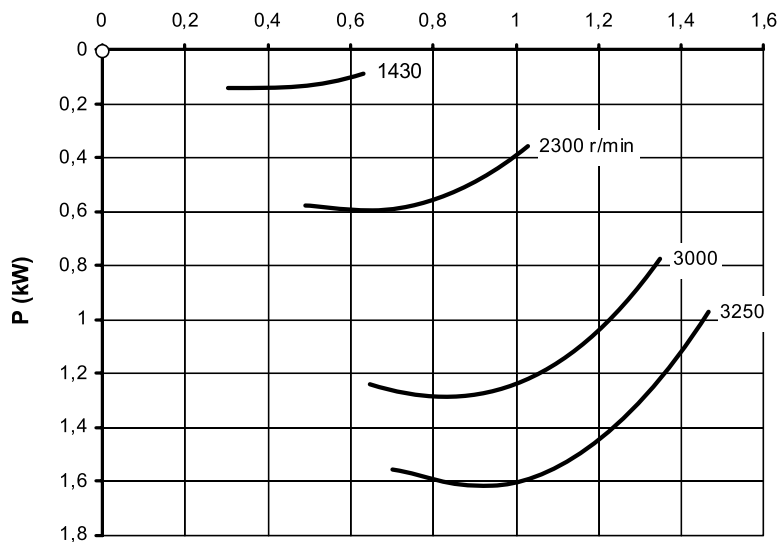
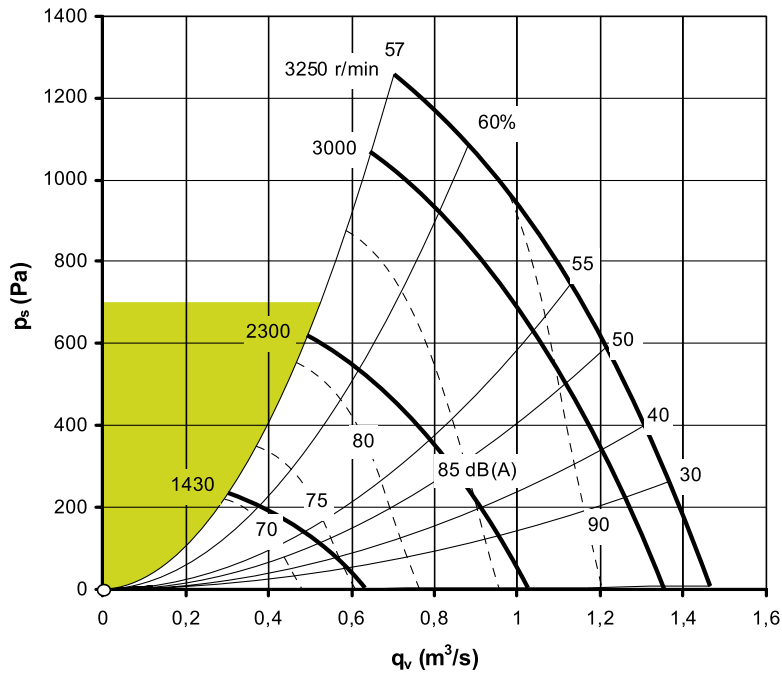

For information about system loss, see product selection tool ACDN.

Fan charts

Plenum fan EQLK with EC-motor

EQLK-01 1-2/O14-2, 1.7 kW

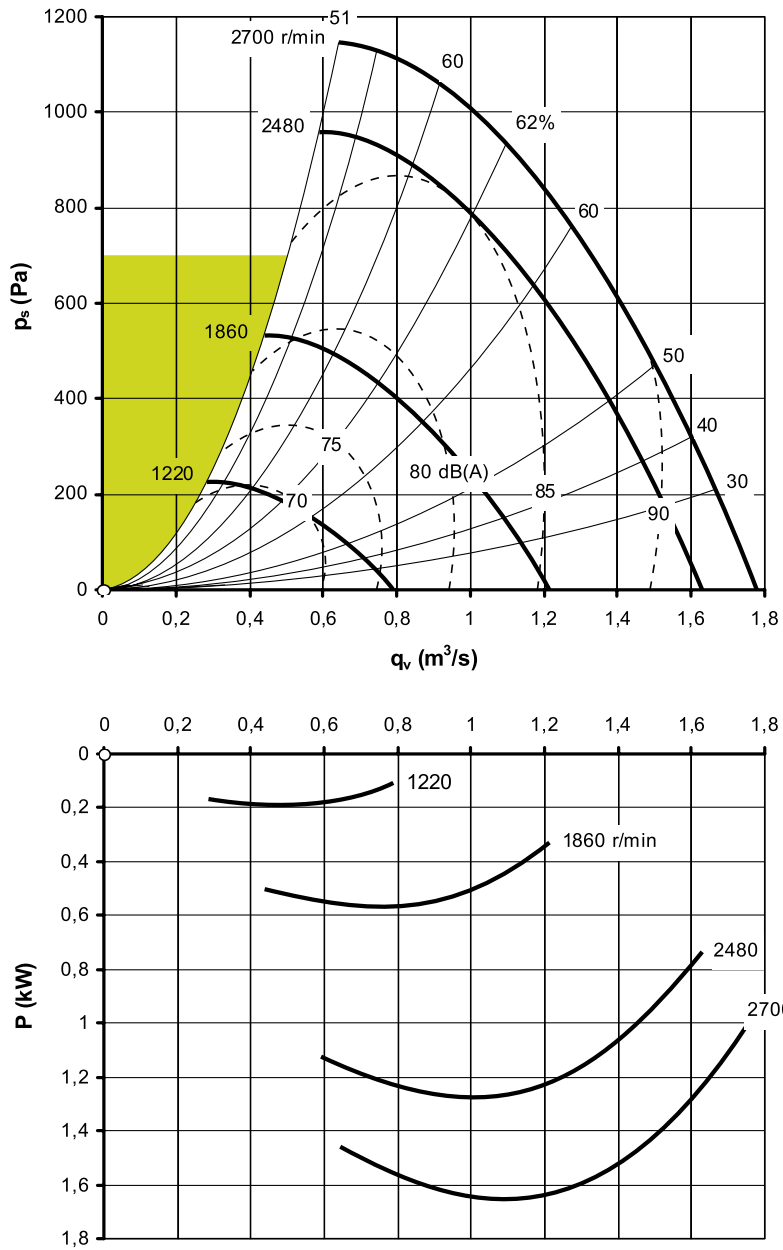

For information about system loss, see product selection tool ACON.

Fan charts

Plenum fan EQLK with EC-motor

Plenum fan EQLT with EC-motor for eQ Top

EQLK-01 1-2/014-2, EQLT-01 1-2, 3 kW

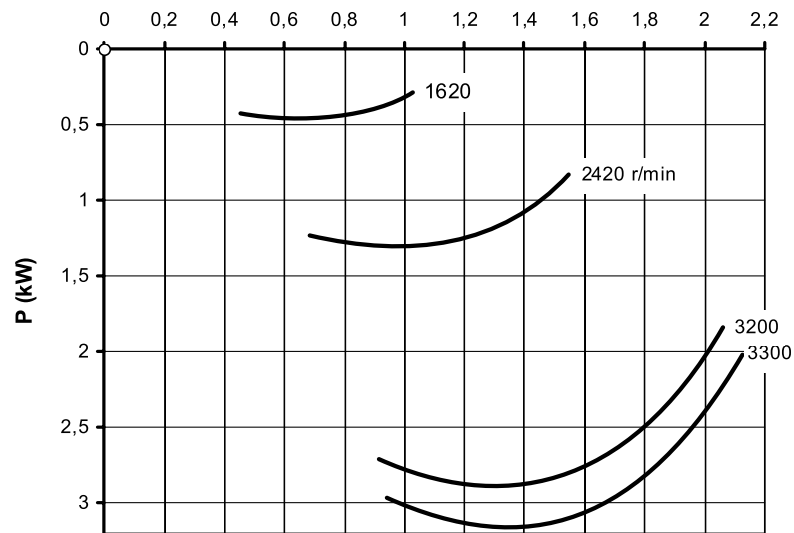
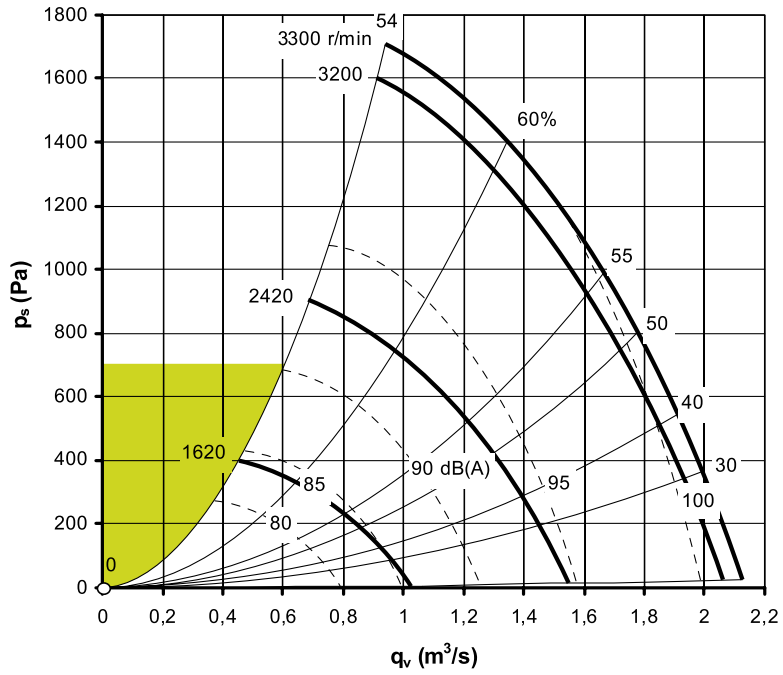

For information about system loss, see product selection tool ACON.

Fan charts

Plenum fan EQLK with EC-motor

Plenum fan EQLT with EC-motor for eQ Top

EQLK-O1 1-3/O14-3/O18-2/O20-2, EQLT-O1 1-3

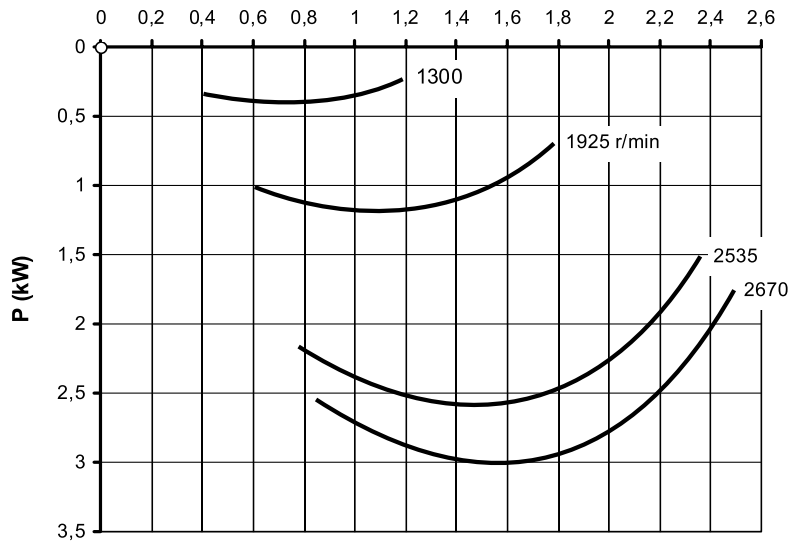
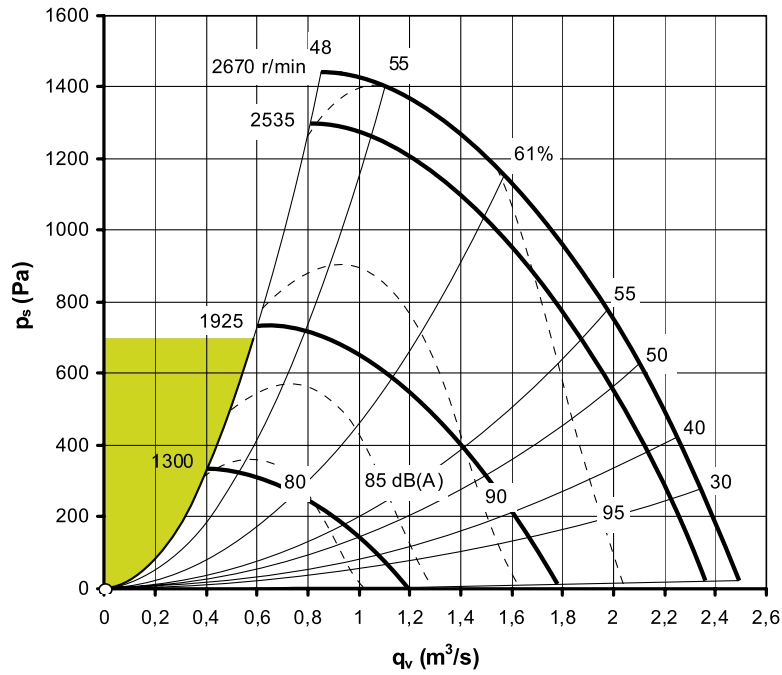

For information about system loss, see product selection tool ACON.

Fan charts

Plenum fan EQLK, EQLT

Description

EQLK-005-2 6

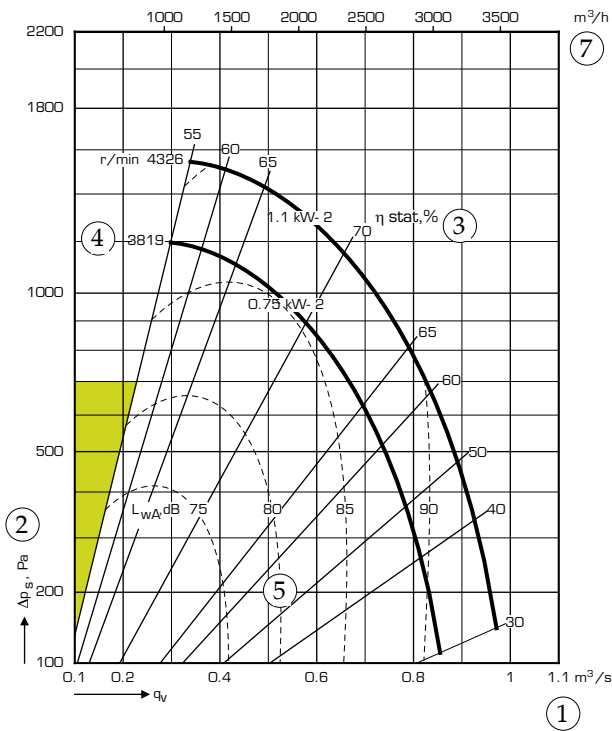

The fan charts give a general view. For more precise information, see product selection tool ACON.

The fan charts on the pages that follow are applicable to a bare fan and to air with a density of 1,2 kg/m³. When the fan is incorporated in a unit section an system loss will arise. This system loss depends on the components placement before the fan. For more precise information about system loss, see product selection tool ACON.

- 1 = Air flow, m³/s (horizontal axis)
- 2 = Static pressure increase, Δp_s Pa (vertical axis)
- 3 = Fan efficiency, η %
- 4 = Max. speed of each motor, kW-no. of motor poles
- 5 = Total sound power level, L_{wA} (dB), broken line
- 6 = Unit and fan size
- = When the fan is controlled to operate at a lower speed, the duty point is allowed to come to rest within the coloured field.

The plenum fan must always be equipped with a frequency inverter for speed control and slow starts.

Fan charts

Plenum fan EQLK

Plenum fan EQLT for eQ Top

EQLK-005-2

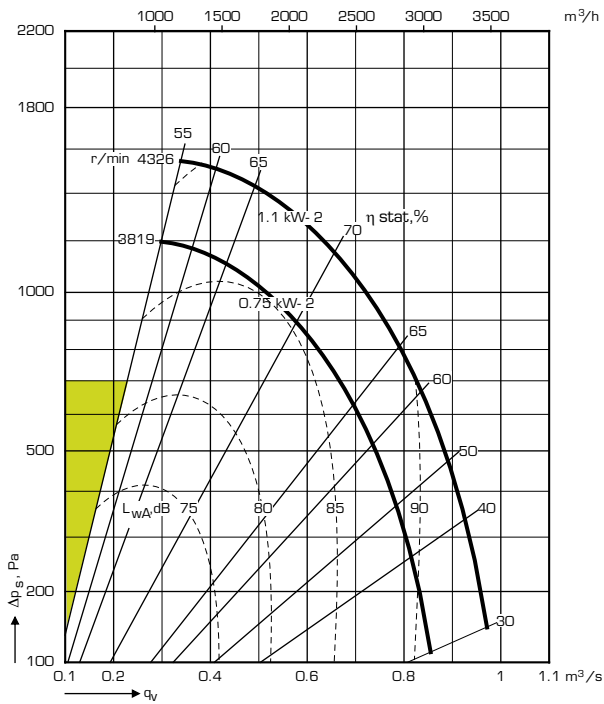

EQLK-008-3/009-3, EQLT-008-3*

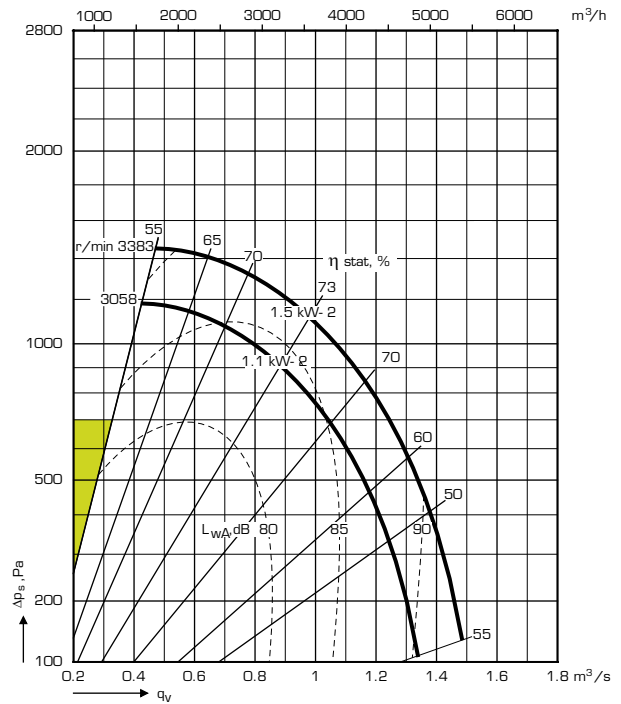

* Only 1.5 kW

EQLK-008-2/009-2, EQLT-008-2*

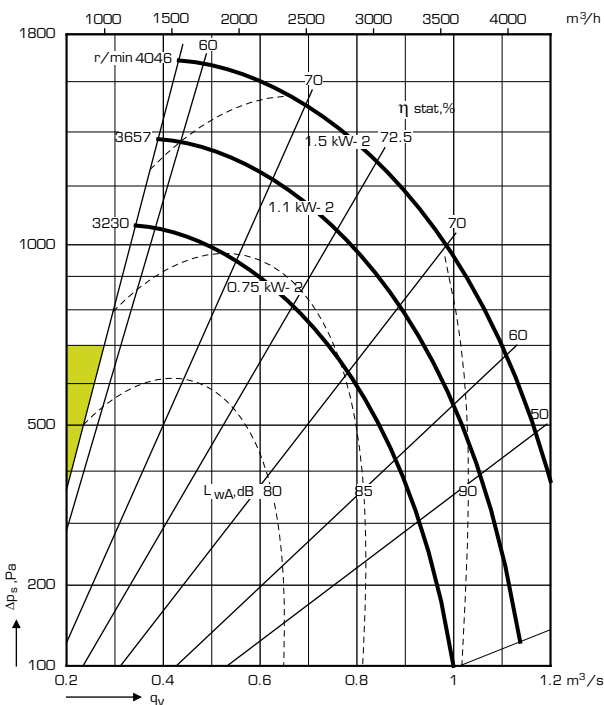

* Only 1.5 kW

EQLK-011-2, EQLT-011-2*

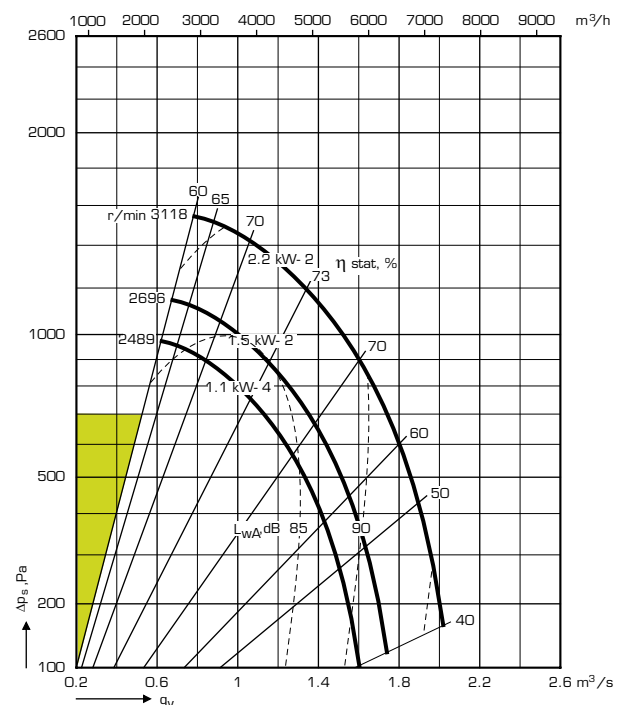

* Only 2.2 kW

For information about system loss, see product selection tool ACON.

Fan charts

Plenum fan EQLK

Plenum fan EQLT for eQ Top

EQLK-01 1-3, EQLT-01 1-3 *

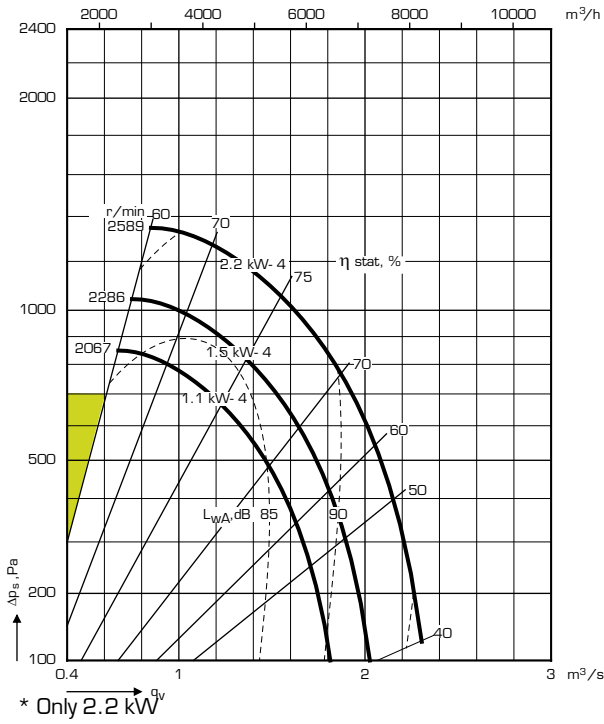

EQLK-014-3

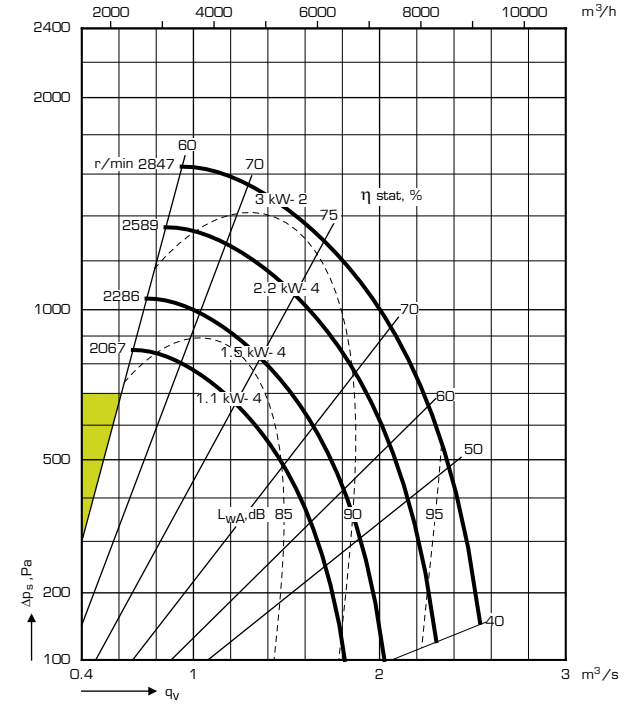

EQLK-014-2

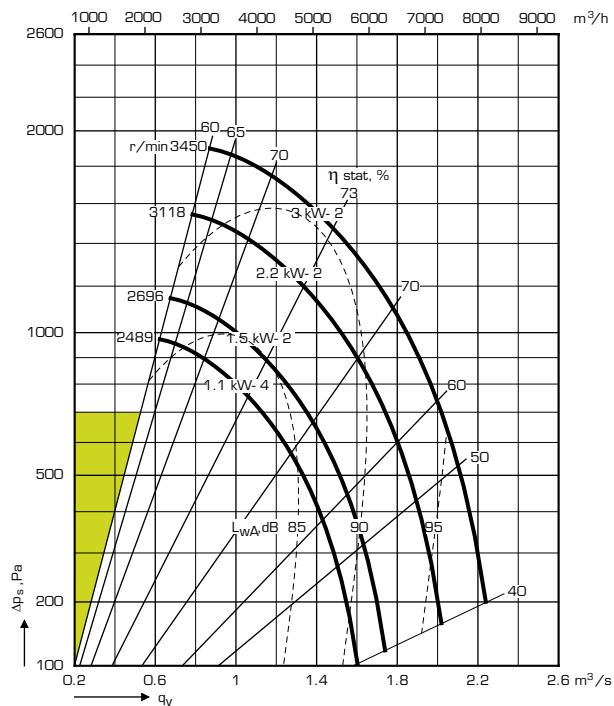

EQLK-018-2

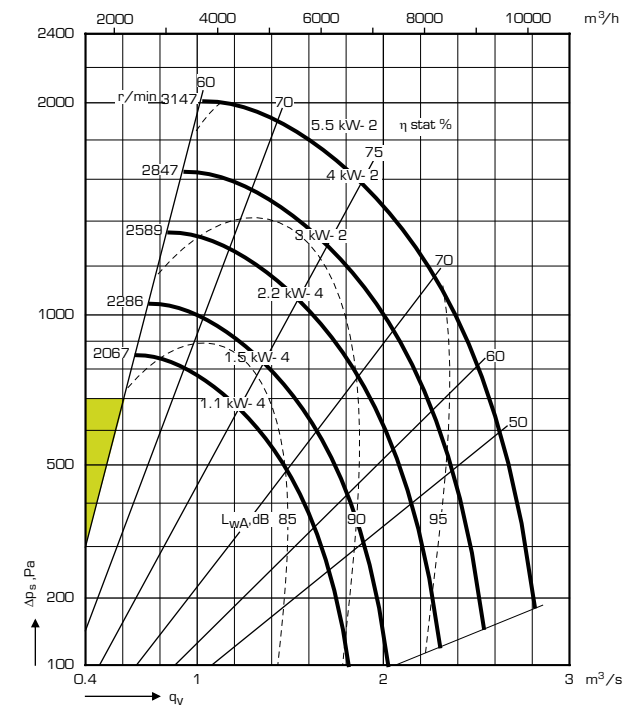

For information about system loss, see product selection tool ACON.

Fan charts

Plenum fan EQLK

EQLK-018-3/020-3

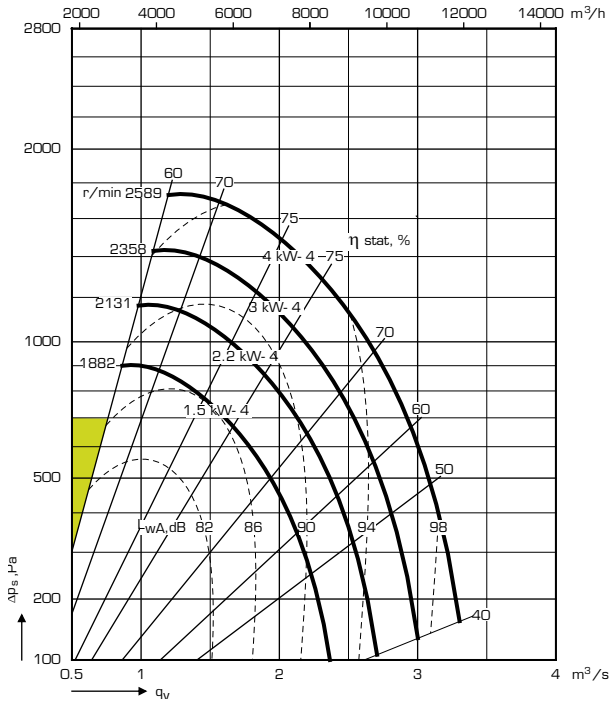

EQLK-023-2/027-2

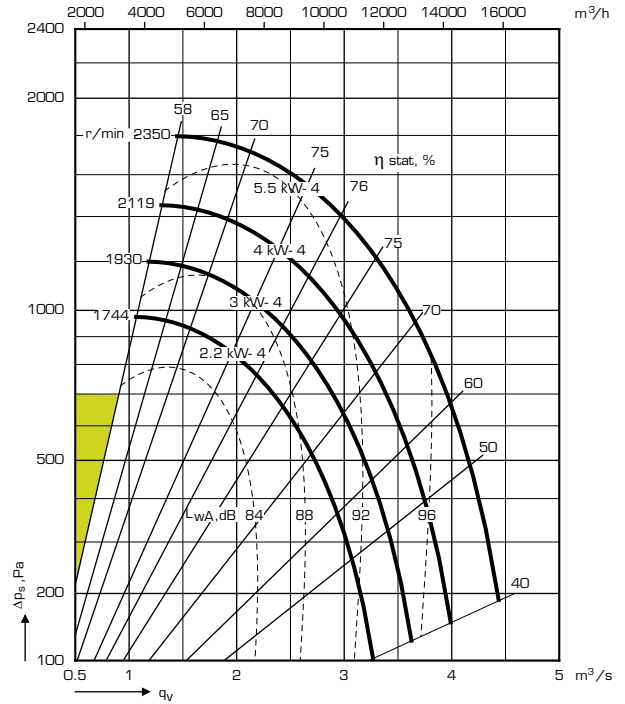

EQLK-020-2

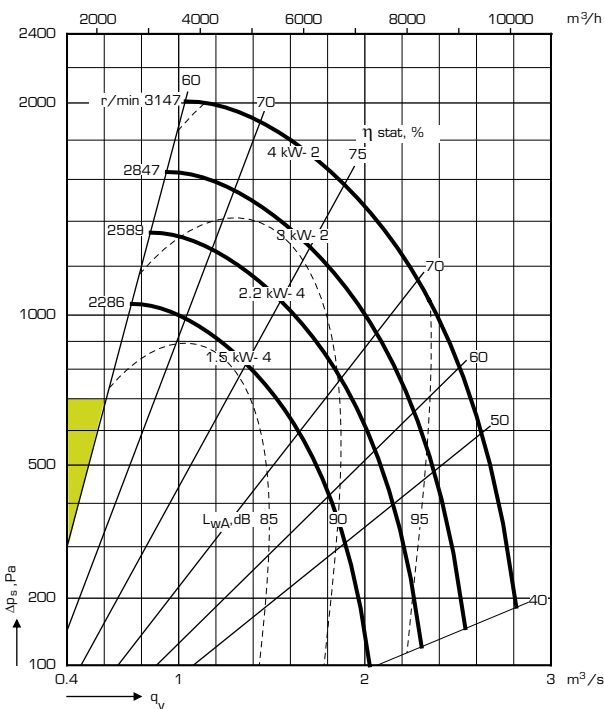

EQLK-023-3/027-3

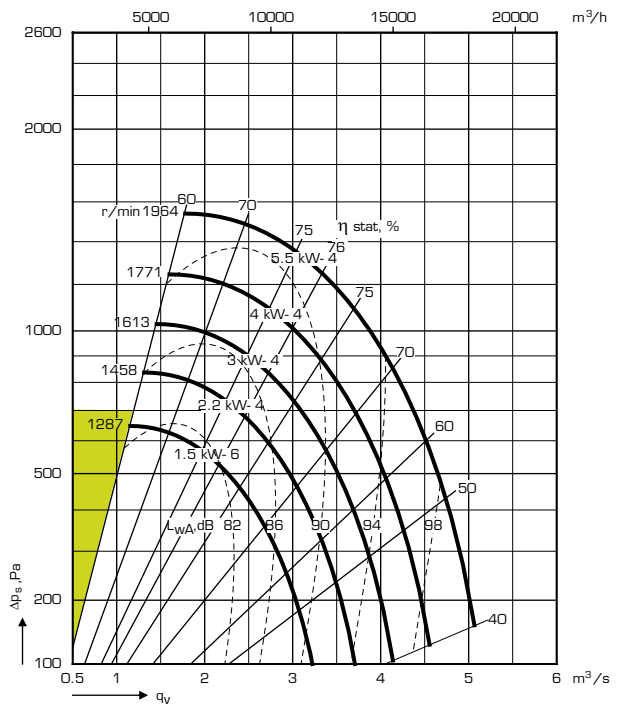

For information about system loss, see product selection tool ACON.

Fan charts

Plenum fan EQLK

EQLK-032-2/036-2

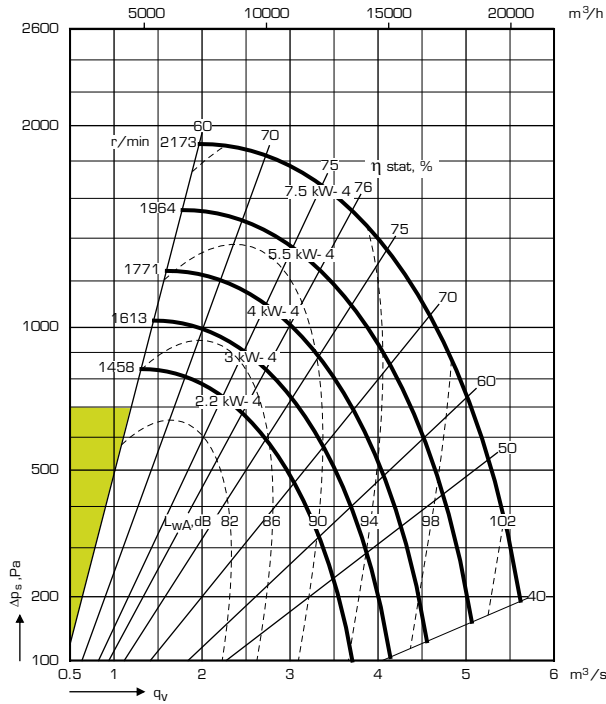

EQLK-041-3

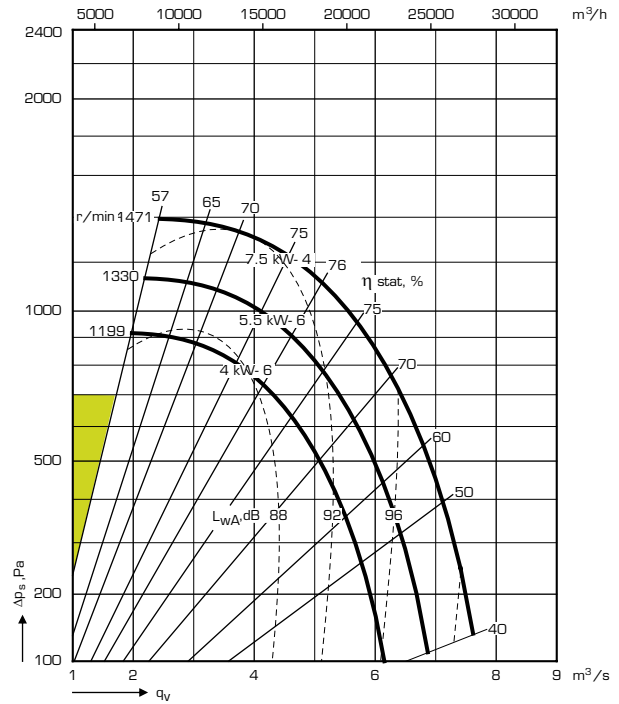

EQLK-032-3/036-3/041-2

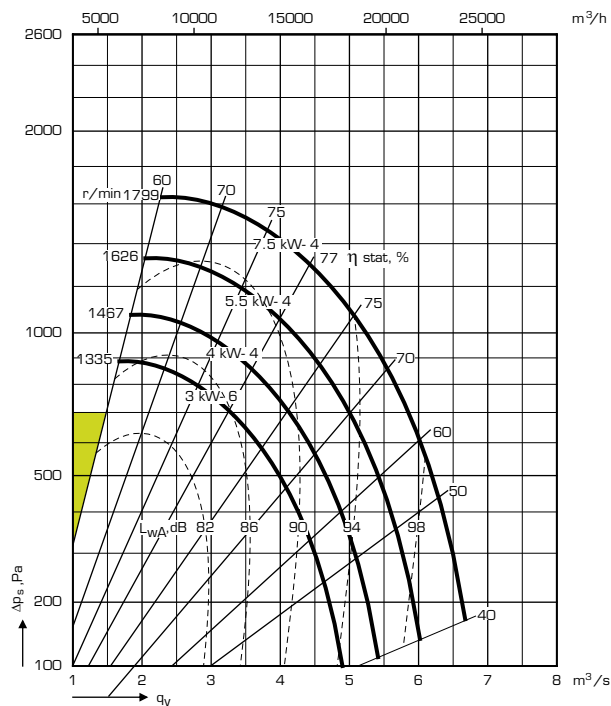

EQLK-045-2

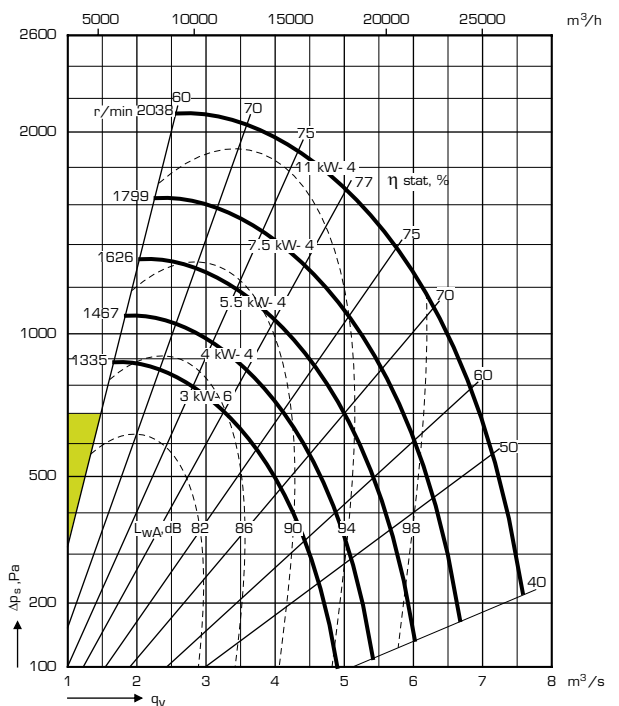

For information about system loss, see product selection tool ACON.

Fan charts

Plenum fan EQLK

EQLK-045-3/050-2/054-2

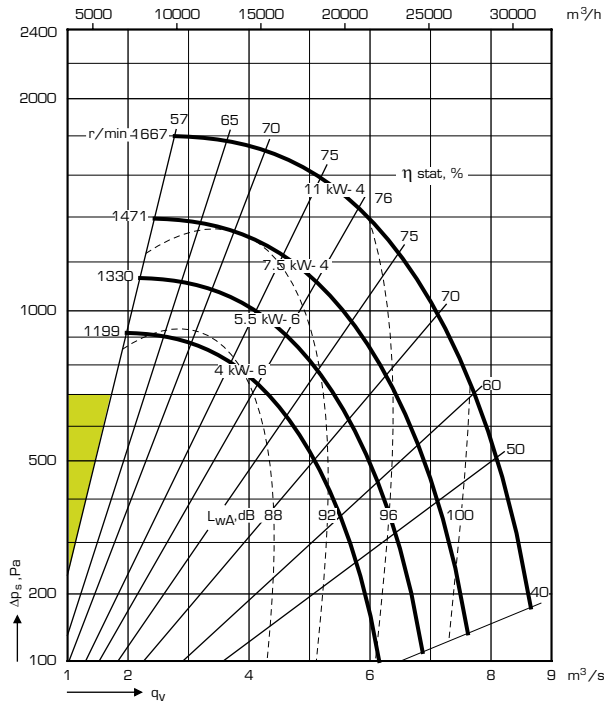

EQLK-056-2

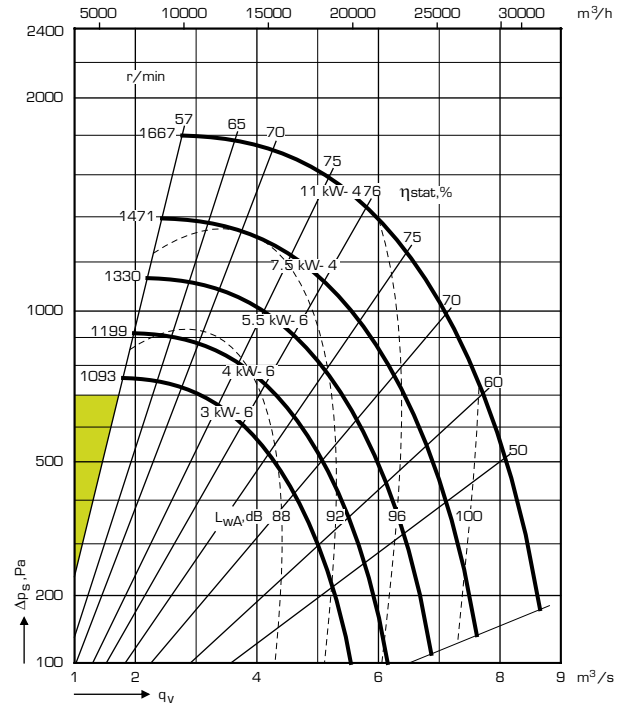

EQLK-050-3/054-3

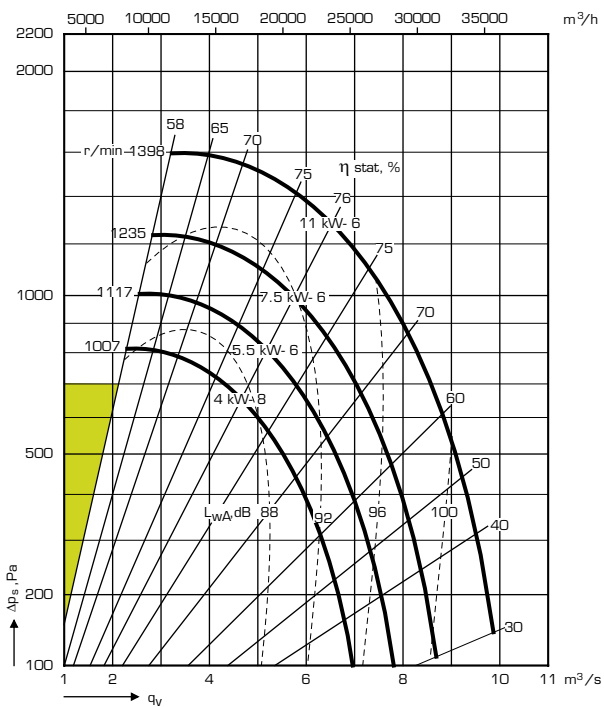

EQLK-056-3/068-2/072-3/079-2

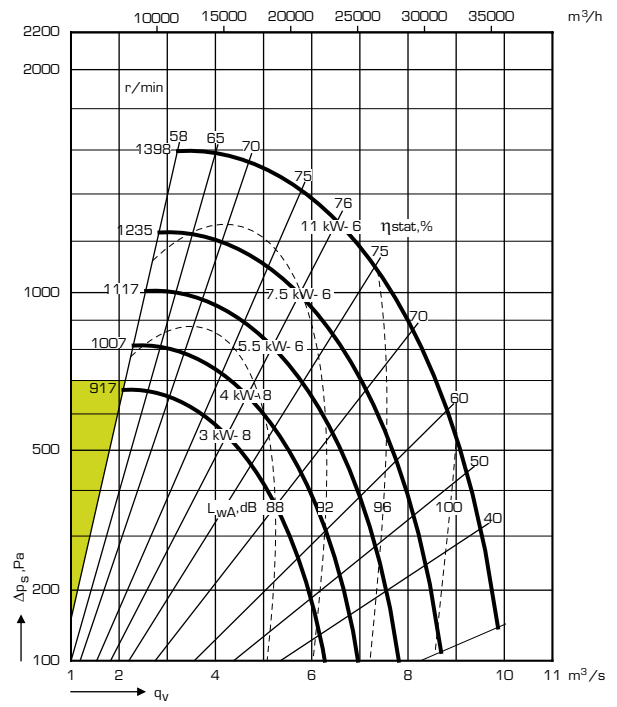

For information about system loss, see product selection ACON.

tool

Fan charts

Plenum fan EQLK

EQLK-063-2/072-2

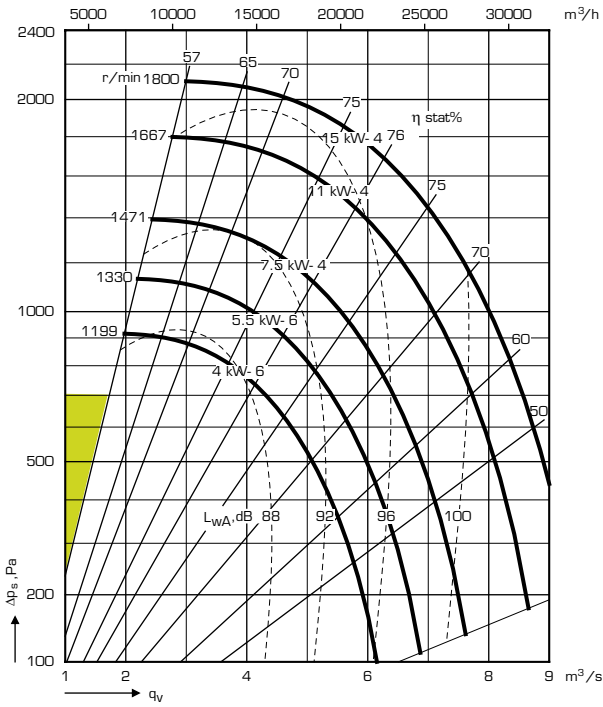

EQLK-068-3

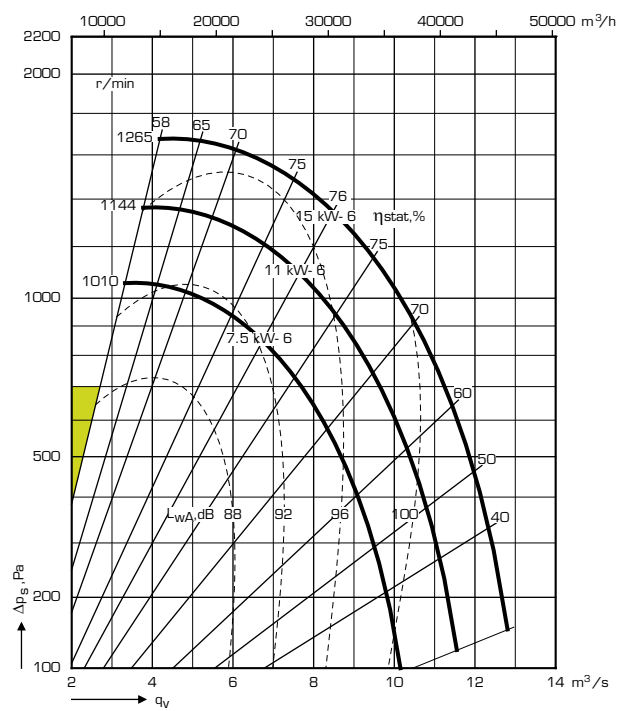

EQLK-063-3, 072-3

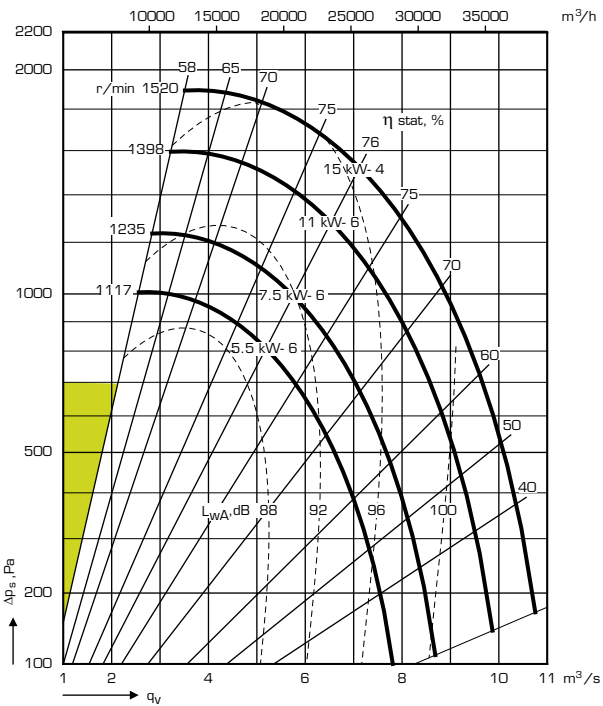

EQLK-079-3/090-2

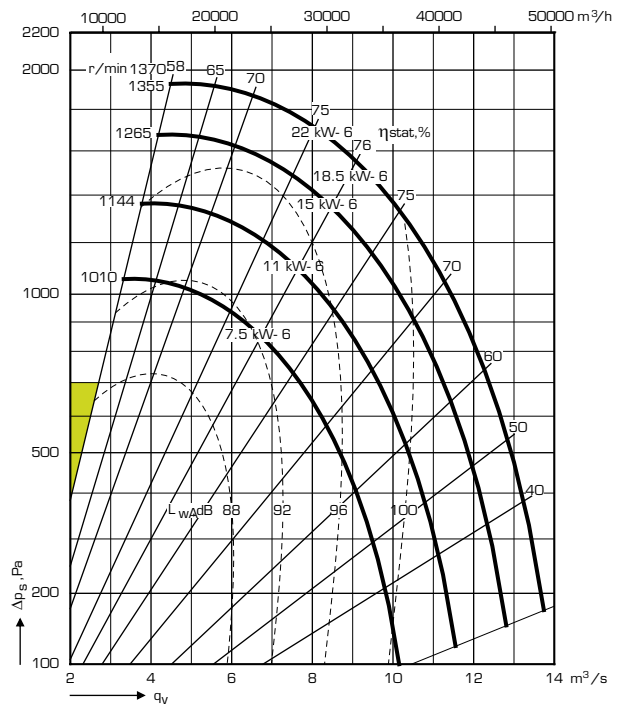

Fan charts

Plenum fan EQLK

EQLK-090-3

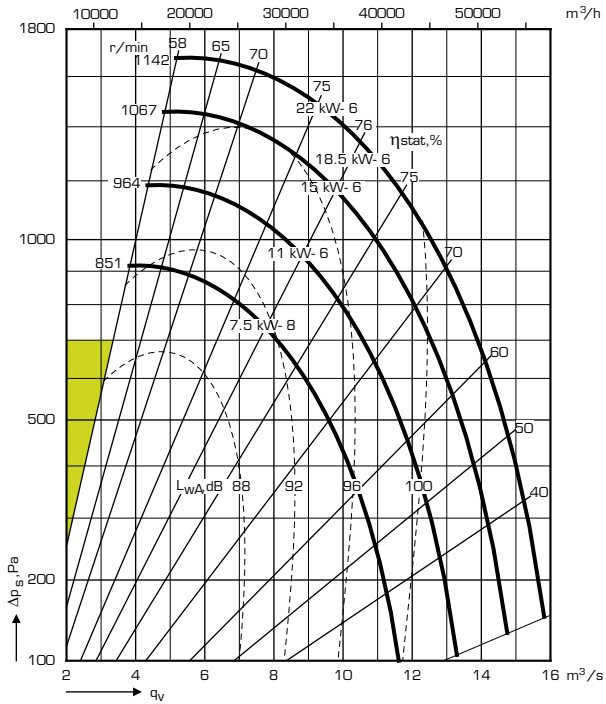

Fan charts

Radial fan, B-wheel EQLR
Description

EQLR-008-3/009-2

10

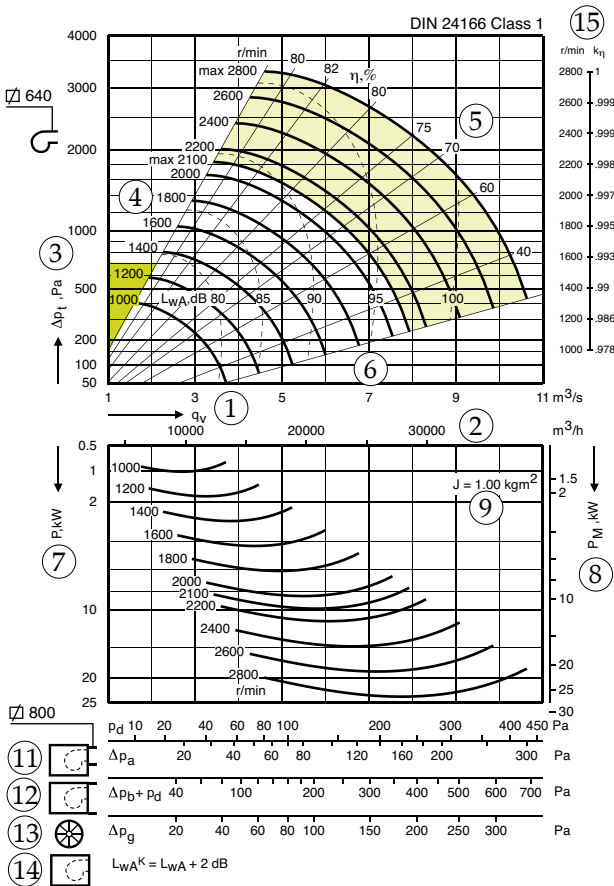

Bearing losses are included in the fan's power demand and affect efficiency

In fan charts, the fan's power demand is defined as the power demand at the fan shaft, which means that its bearing losses are included. The efficiency figures shown on the chart are valid for maximum speed, and are a few percentage points lower than they would be if the bearing losses were ignored. As the speed drops, the fan power falls in proportion to the third power of the speed, while the bearing losses fall only linearly proportionally to the speed. This means that, at lower speeds, the bearing losses become a higher proportion of the total losses while the efficiency becomes correspondingly lower.

Fan charts for fans with backward-curved impellers include a scale for k which shows the drop in efficiency at lower speeds. The scale provides high accuracy of determination of k over the normal working range, where the fan's power demand at a given speed is largely independent of the air flow.

The eQ fan charts on the pages that follow are applicable to air with a density of 1.2 kg/m³.

- ① = Air flow, m³/s (x-axel)
- ② = Air flow, m³/h (x-axel)
- ③ = Total pressure rise, Δp_t Pa (y-axel)
- ④ = Fan speed, r/min
- ⑤ = Fan efficiency η , %
- ⑥ = Sound power level L_{WA} (dB), (dotted)
- ⑦ = Fan shaft power, P (kW)
- ⑧ = Min. recommended motor rating for direct on-line starting, P_M (kW)
- ⑨ = Mass moment of inertia J (kg m²)
- ⑩ = Unit size and fan size
- ⑪ = Pressure losses to the standardized outlet duct, Δp_a (Pa)
- ⑫ = Pressure losses through distributor section, $\Delta p_b + p_d$ (Pa)
- ⑬ = Pressure losses in inlet guide vanes for fans with backward-curved blades p_g (Pa). This pressure loss should be added to the external and internal pressure drops before selecting the operating point in the fan chart.
- ⑭ = $L_{WA}^K = L_{WA} + 2$ dB
- ⑮ = Correction factor for efficiency, $k\eta$
- = Recommended working range of the fan
- = Working range for reinforced fans
- = When the fan is controlled to operate at a lower speed, the duty point is allowed to come to rest within the coloured field.

Fan charts

Radial fan, B-wheel EQLR

EQLR-008-3/009-2

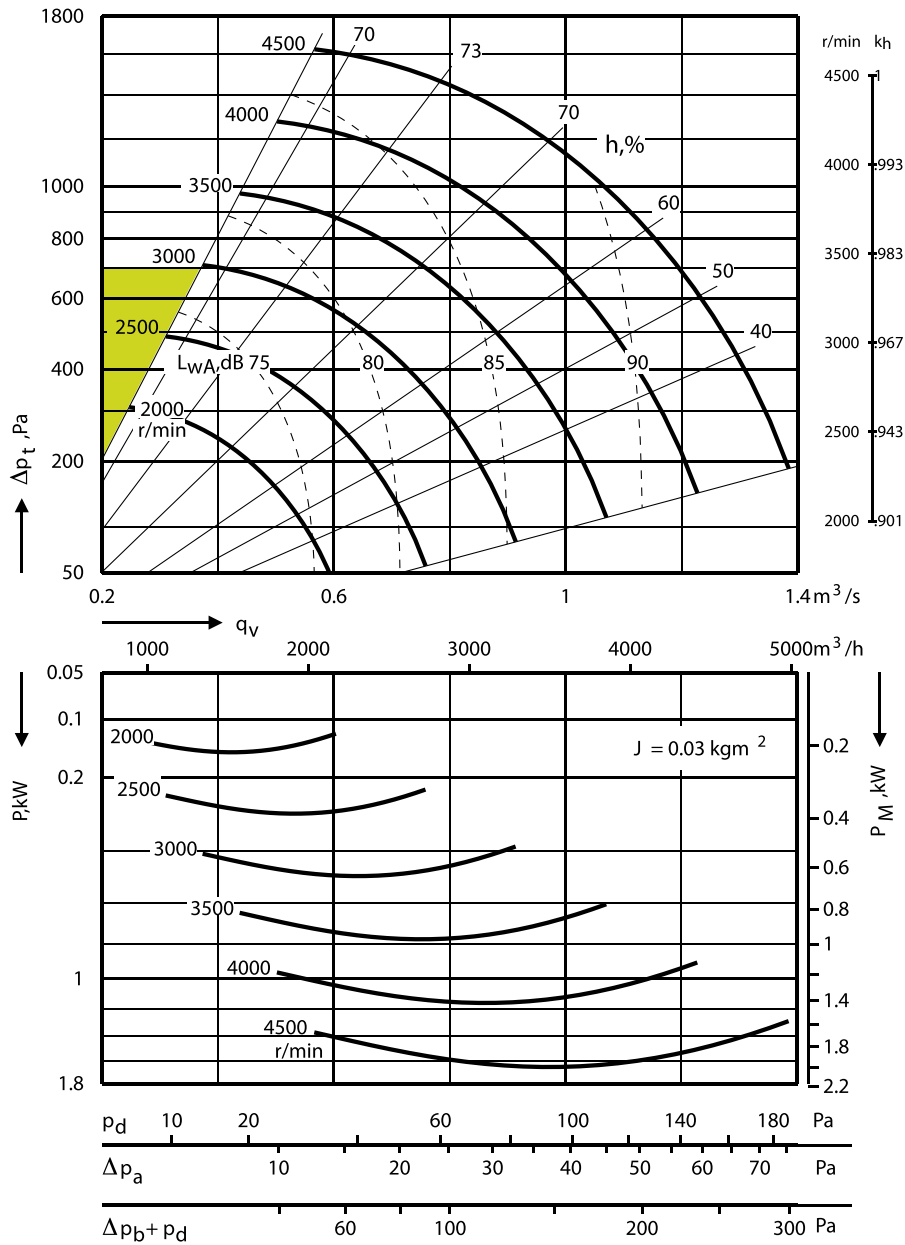

For information about system loss, see product selection tool ACON.

Fan charts

Radial fan, B-wheel EQLR

EQLR-009-3/O1 1-2

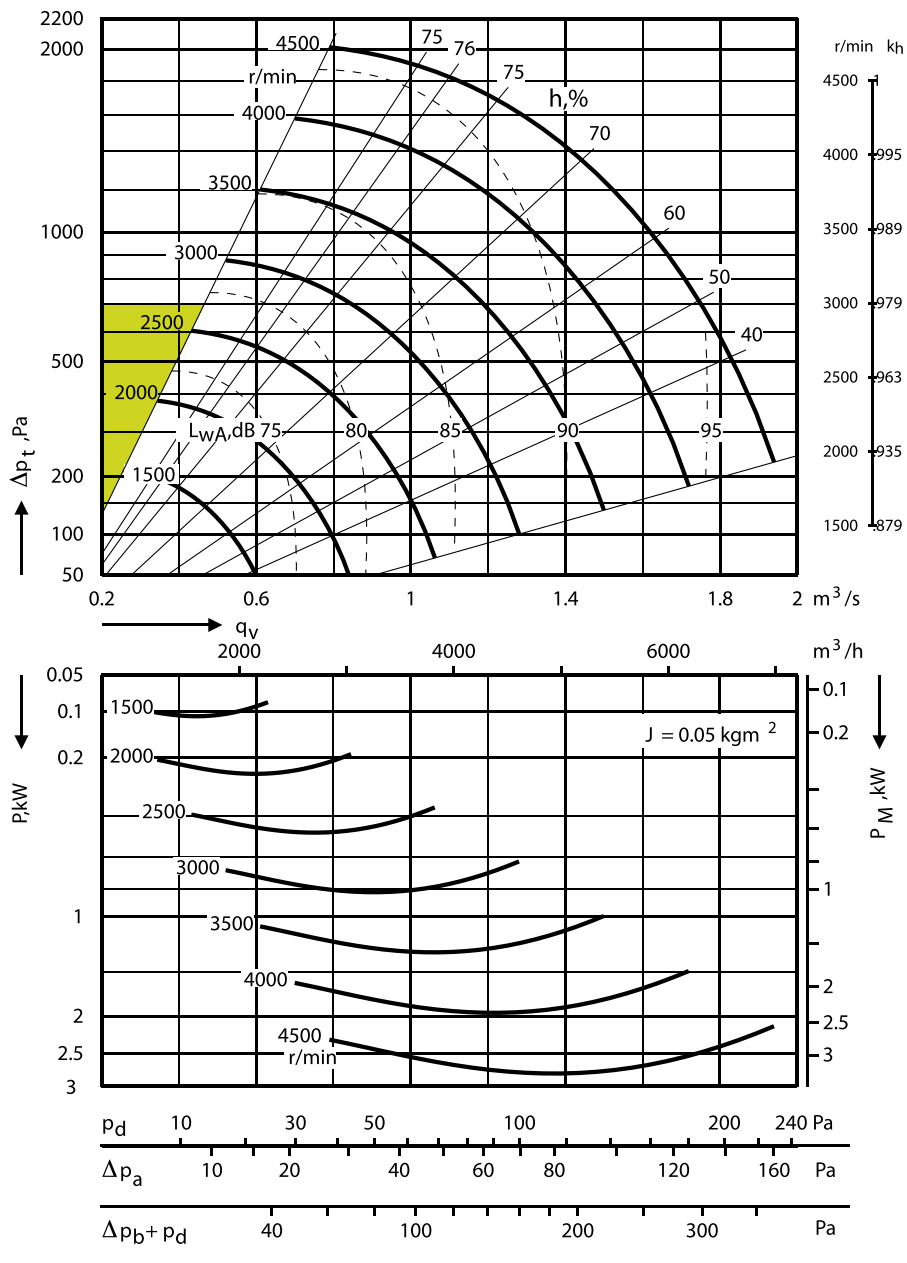

For information about system loss, see product selection tool ACON.

Fan charts

Radial fan, B-wheel EQLR

EQLR-01 1-3/O14-2

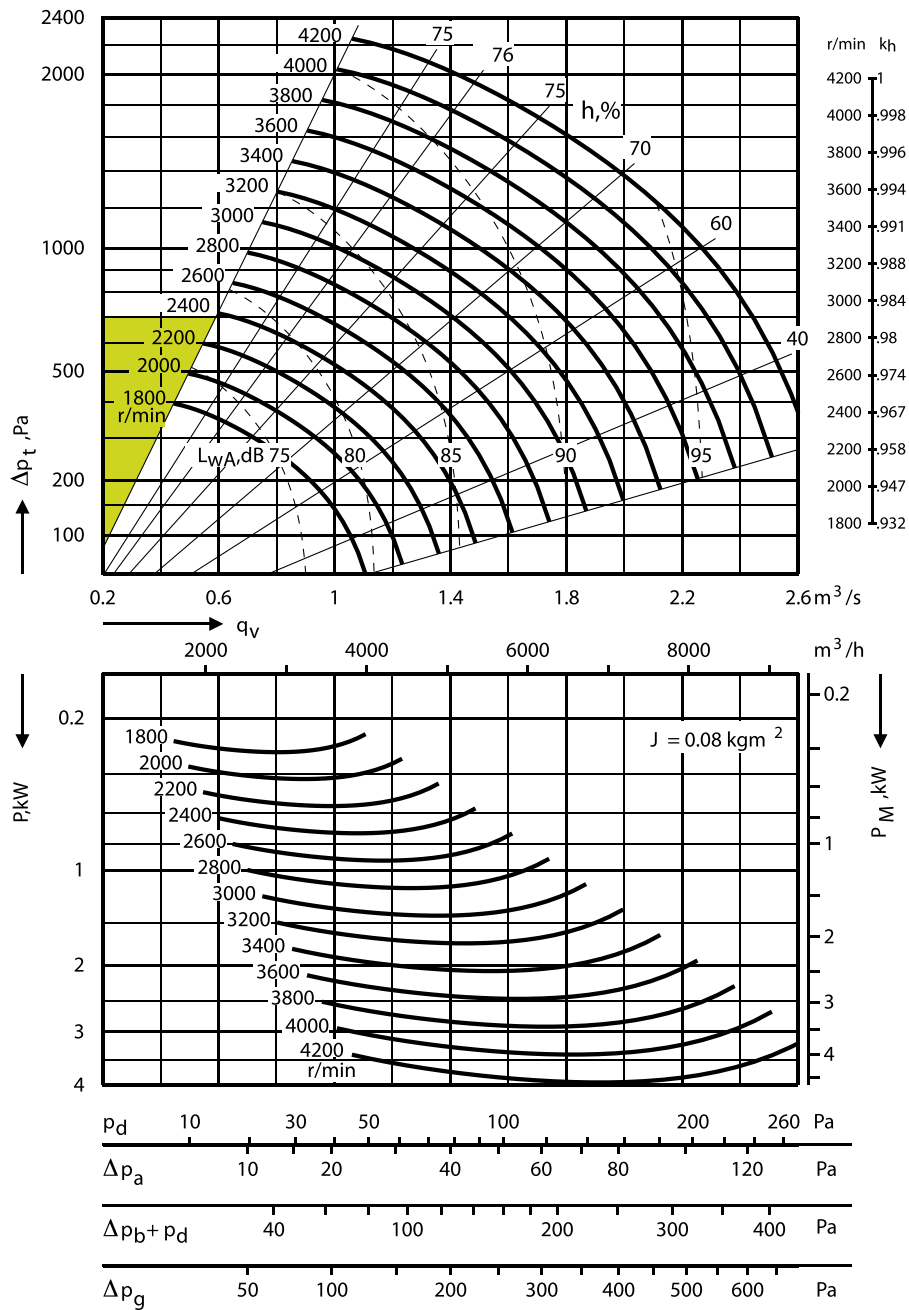

For information about system loss, see product selection tool ACON.

Fan charts

Radial fan, B-wheel EQLR

EQLR-014-3/018-2/020-2

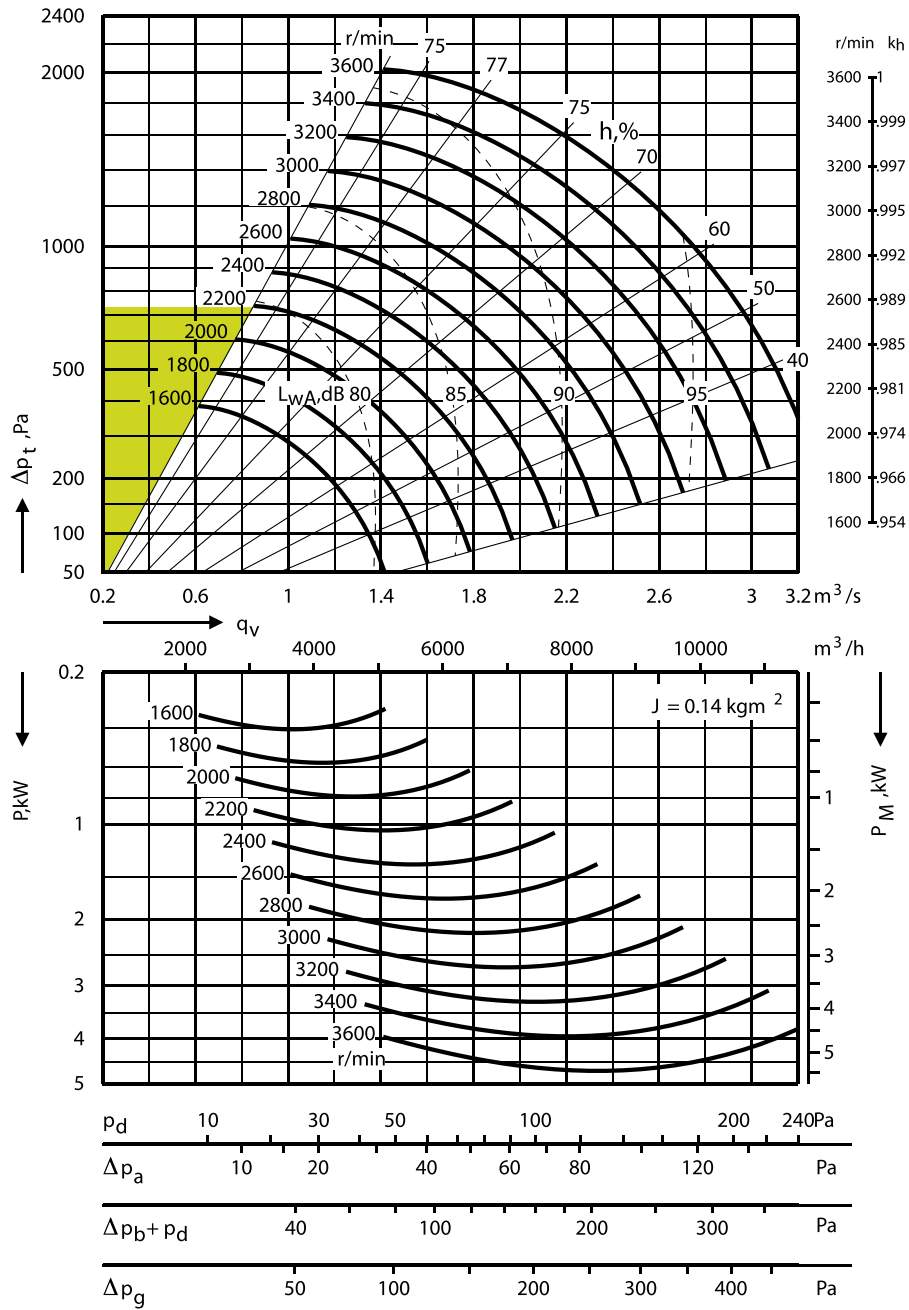

For information about system loss, see product selection tool ACON.

Fan charts

Radial fan, B-wheel EQLR

EQLR-018-3/020-3/023-2/027-2

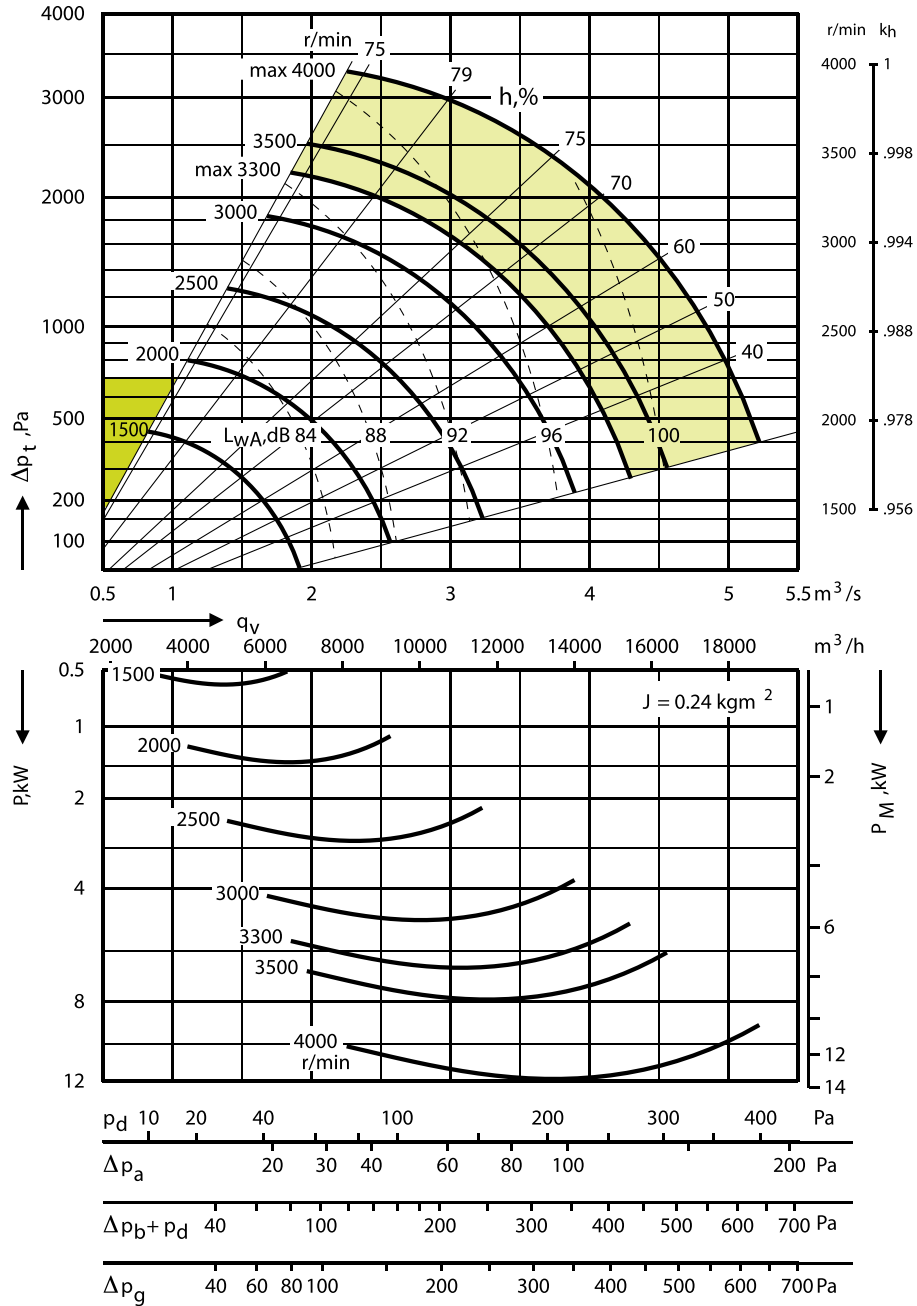

For information about system loss, see product selection tool ACON.

Fan charts

Radial fan, B-wheel EQLR

EQLR-023-3/027-3/032-2/036-2

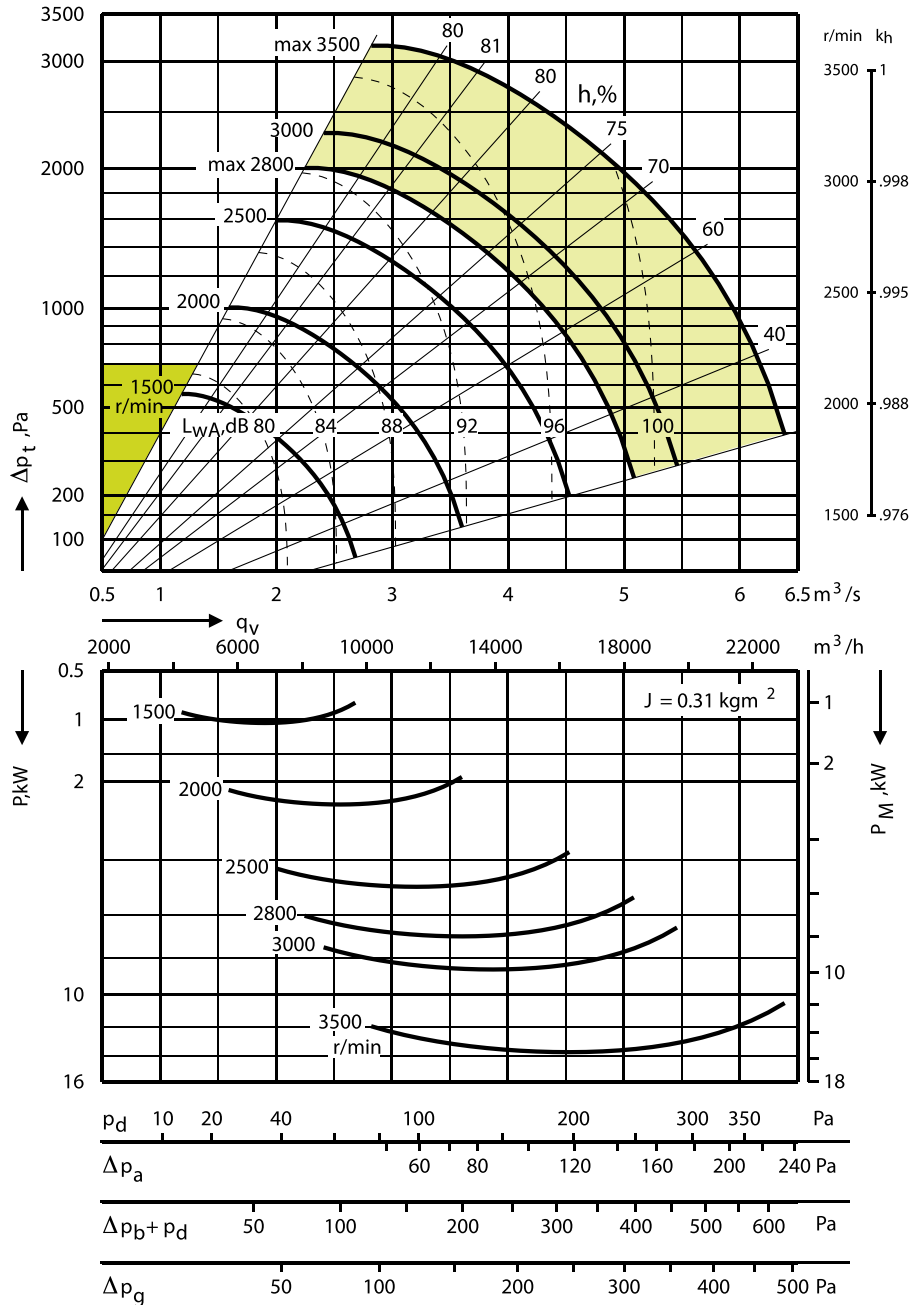

For information about system loss, see product selection tool ACON.

Fan charts

Radial fan, B-wheel EQLR

EQLR-032-3/036-3/041-2/045-2

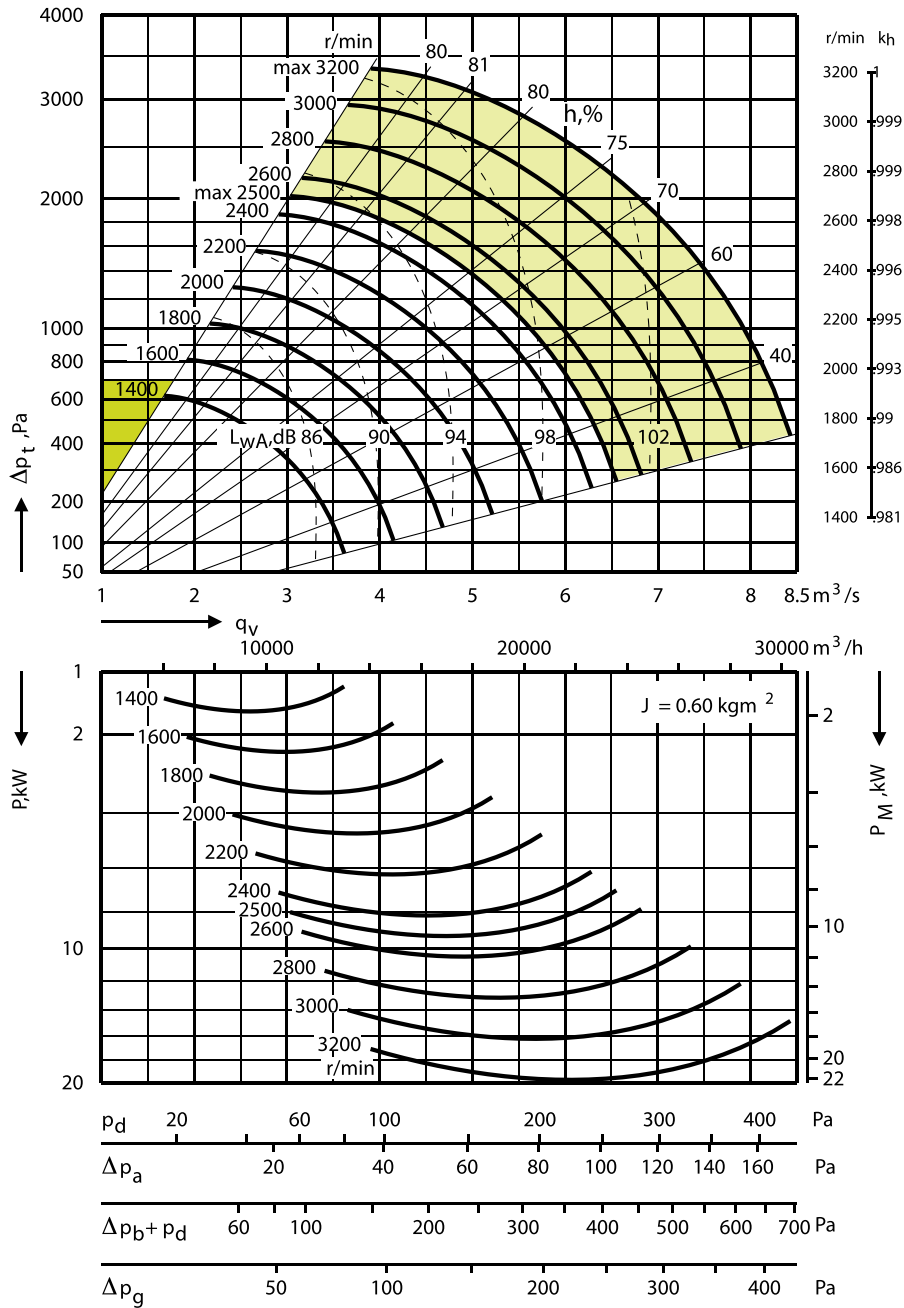

For information about system loss, see product selection tool ACON.

Fan charts

Radial fan, B-wheel EQLR

EQLR-041-3/045-3/050-2/054-2/056-2

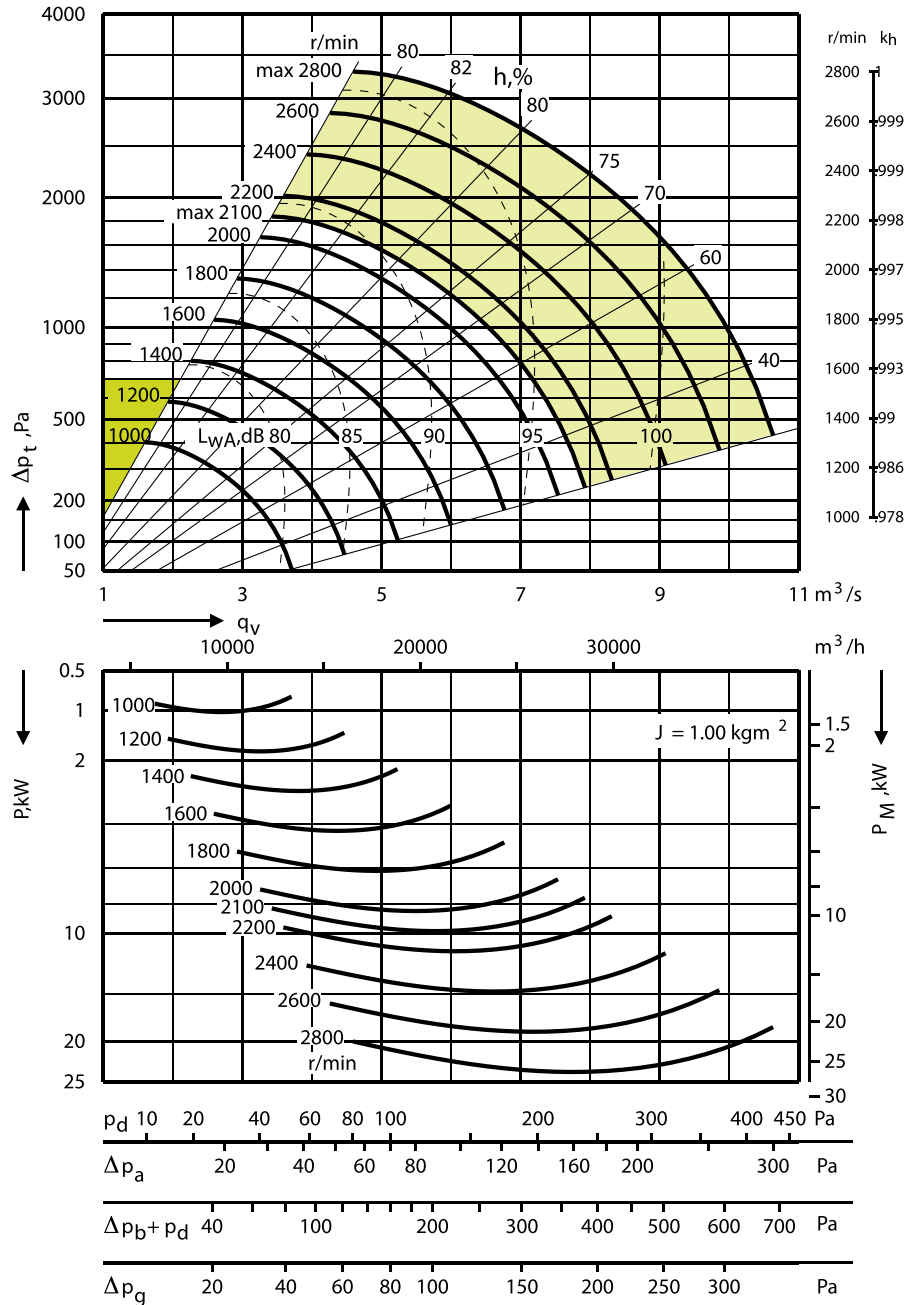

For information about system loss, see product selection tool ACON.

Fan charts

Radial fan, B-wheel EQLR

EQLR-050-3/054-3/056-3/063-2/068-2/072-2/079-2

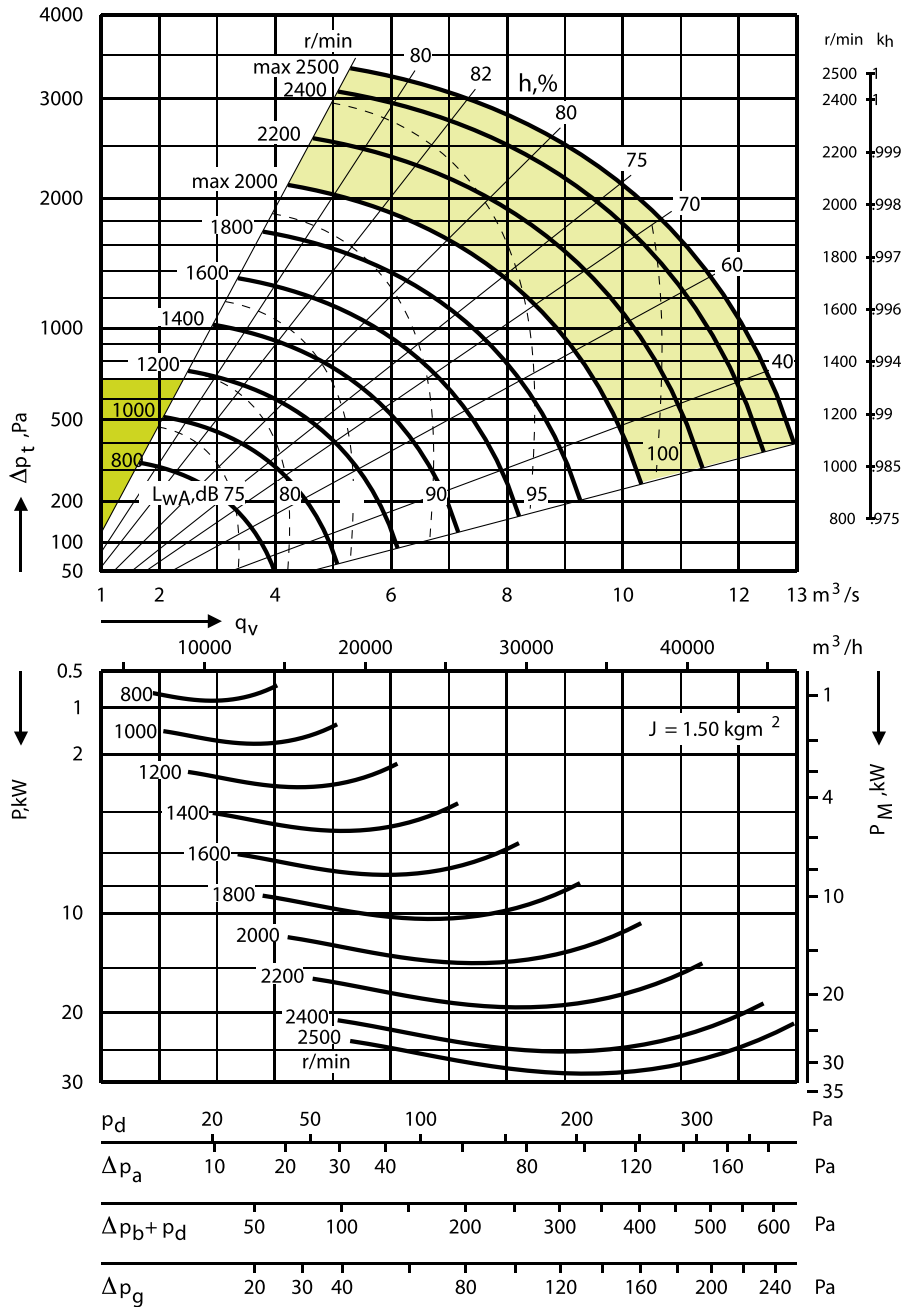

For information about system loss, see product selection tool ACON.

Fan charts

Radial fan, B-wheel EQLR

EQLR-063-3/068-3/072-3/079-3/090-2

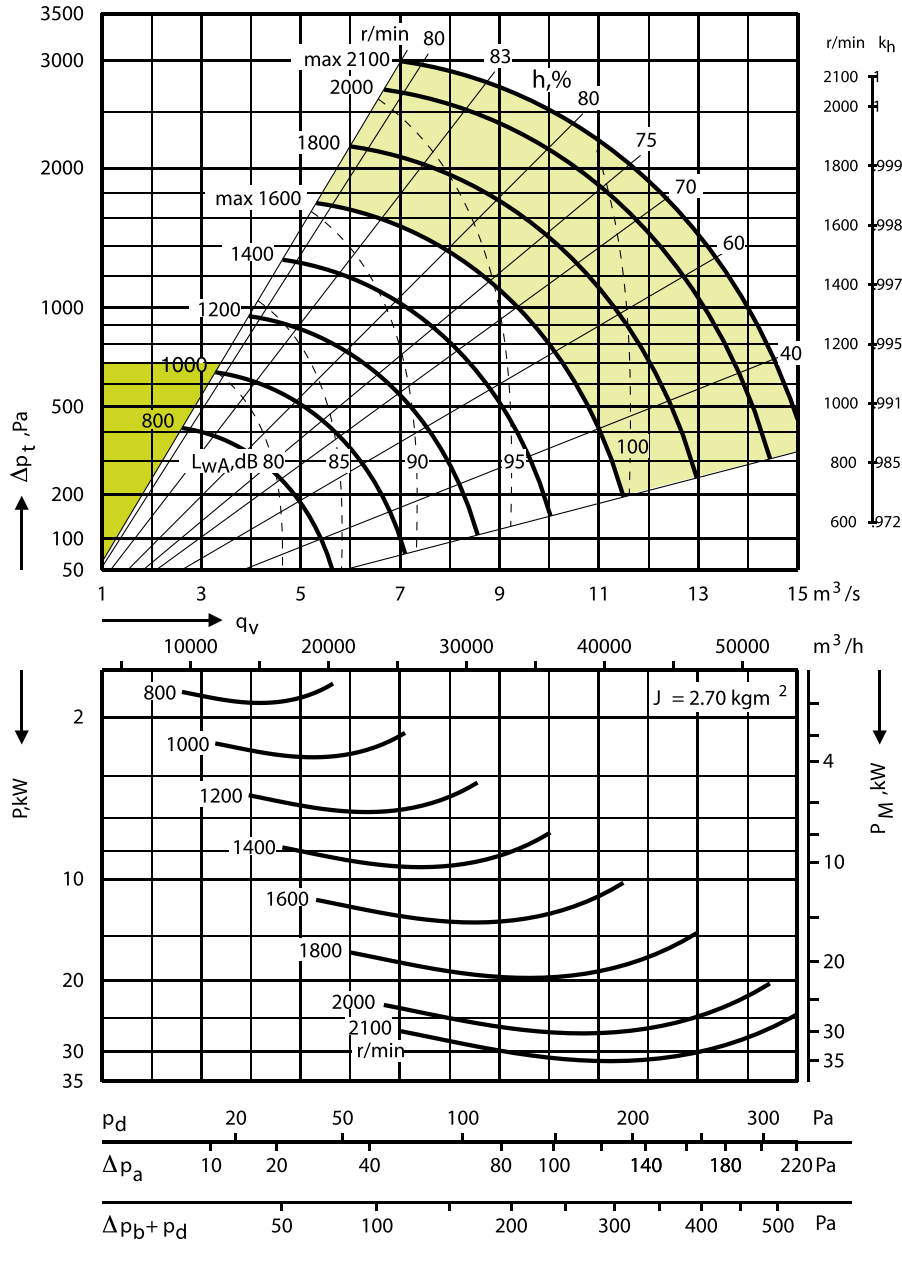

For information about system loss, see product selection tool ACON.

Fan charts

Radial fan, B-wheel EQLR

EQLR-090-3

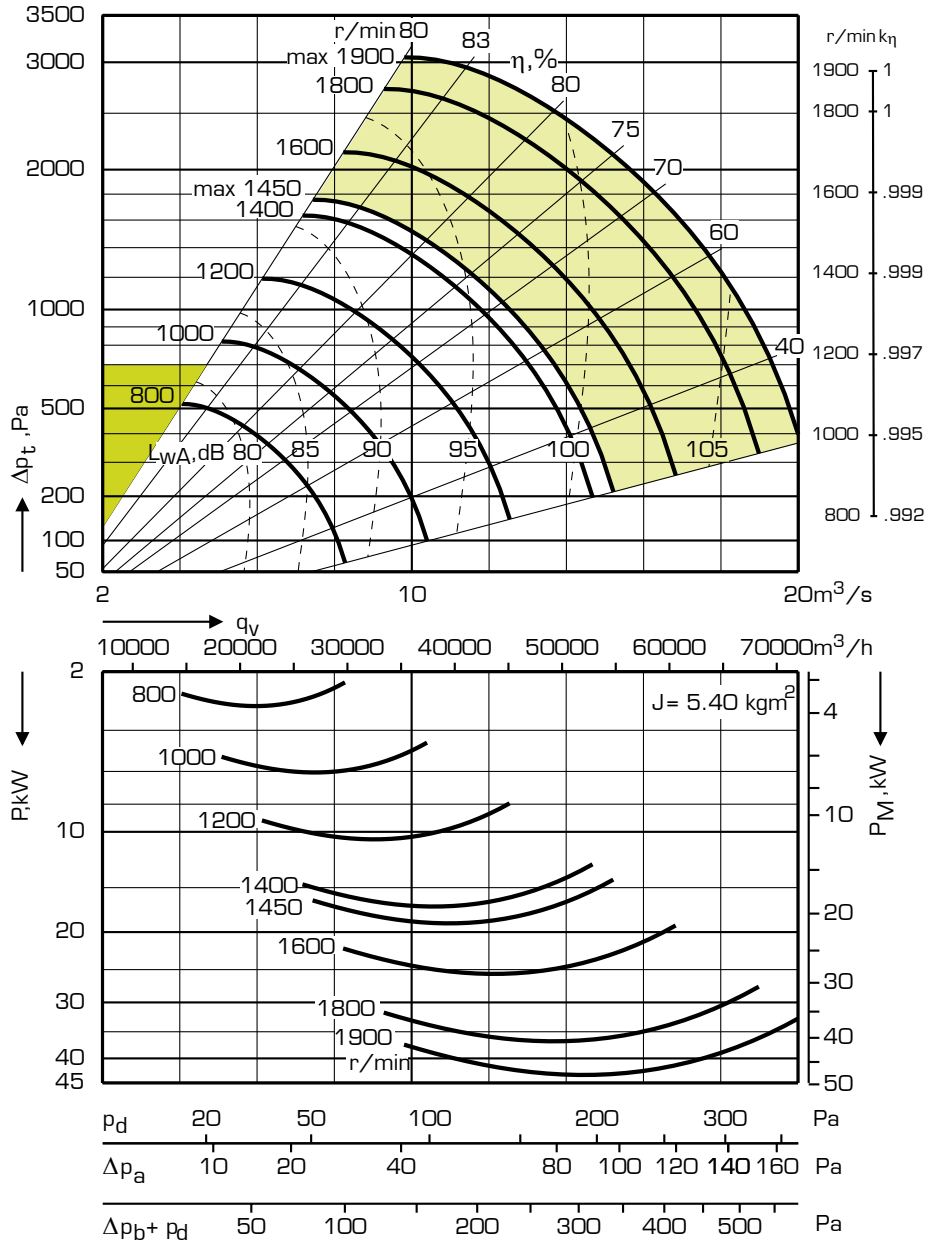

Dimensions and weights (mm and kg)

EQGA and EQGB Unit casing (single casing)

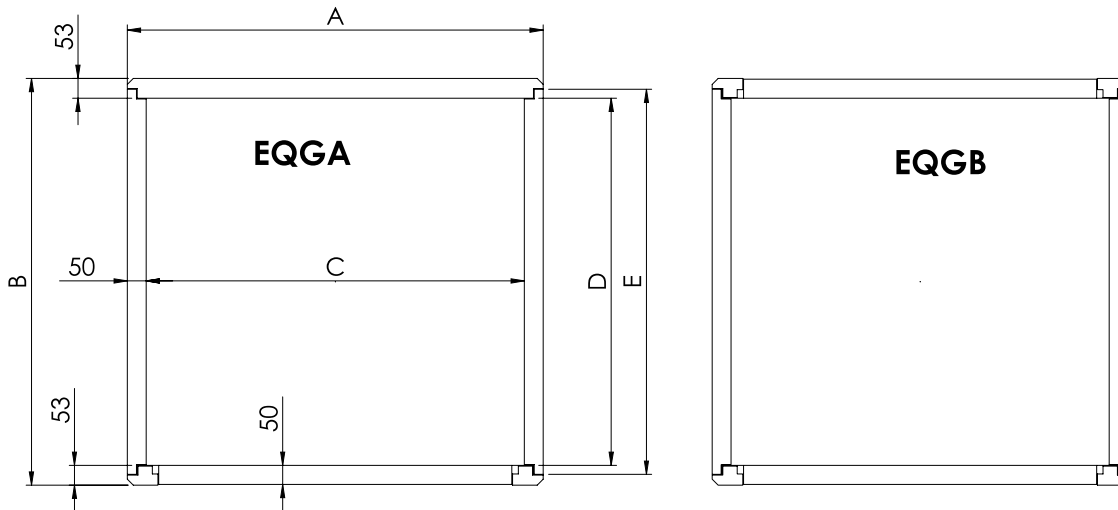

Size	Code	A	B	C	D	E
005	EQGA	800	476	700	370	420
008	EQGA	1100	576	1000	470	520
009	EQGA	800	776	700	670	720
011	EQGA	1200	676	1100	570	620
014	EQGA	1100	776	1000	670	720
018	EQGA	1400	776	1300	670	720
020	EQGA	1100	1076	1000	970	1020
023	EQGB	1700	926	1600	820	870
027	EQGA	1400	1076	1300	970	1020
032	EQGB	1800	1026	1700	920	970
036	EQGA	1400	1376	1300	1270	1320
041	EQGB	2000	1076	1900	970	1020
045	EQGB	1700	1376	1600	1270	1320
050	EQGB	2300	1226	2200	1120	1170
054	EQGB	2000	1376	1900	1270	1320
056	EQGB	1700	1676	1600	1570	1620
063	EQGB	2300	1376	2200	1270	1320
068	EQGB	2000	1676	1900	1570	1620
072	EQGB	2600	1376	2500	1270	1320
079	EQGB	2300	1676	2200	1570	1620
090	EQGB	2600	1676	2500	1570	1620

See product selection tool ACON for information about the weight.

Dimensions and weights (mm and kg)

EQHA and EQHB Unit casing (double casing)

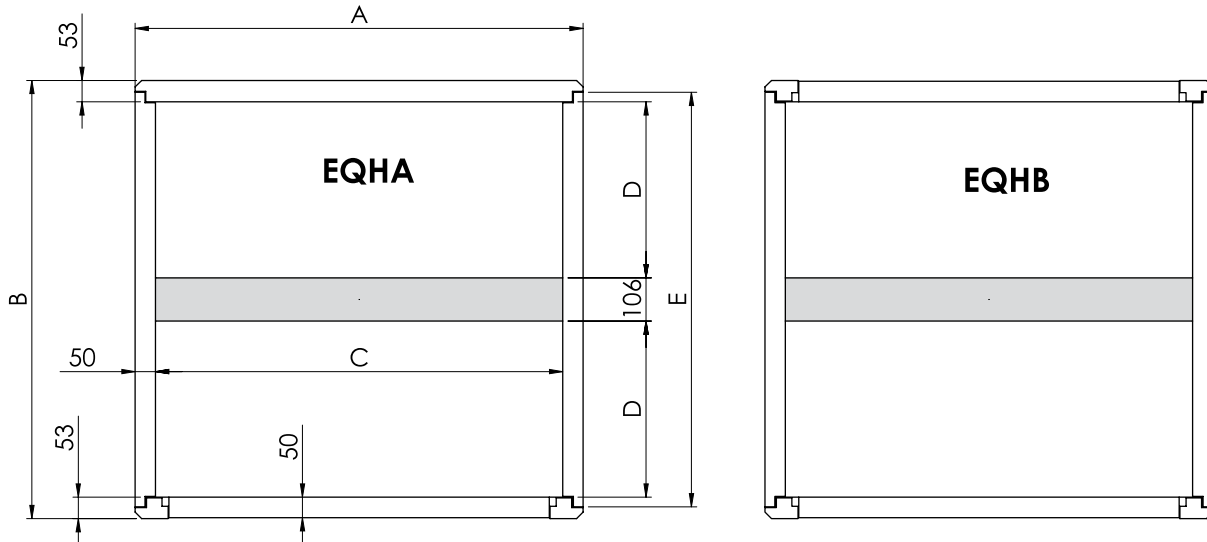

Size	Code	A	B	C	D	E
005	EQHA	800	952	700	370	896
008	EQHA	1100	1152	1000	470	1096
009	EQHA	800	1552	700	670	1496
009*	EQHB	1400	1552	1300	670	1496
011	EQHA	1200	1352	1100	570	1296
014	EQHA	1100	1552	1000	670	1496
014*	EQHB	1400	1552	1300	670	1496
018	EQHA	1400	1552	1300	670	1496
020	EQHB	1100	2152	1000	970	2096
020*	EQHB	1800	2152	1700	970	2096
023	EQHB	1700	1852	1600	820	1796
027	EQHB	1400	2152	1300	970	2096
027*	EQHB	1800	2152	1700	870	2096
032	EQHB	1800	2052	1700	920	1996
036*	EQHB	2400	2752	2300	1270	2696

Size	Code	A	B	C	D	E
036**	EQHB	1400	2752	1300	1270	2696
041	EQHB	2000	2152	1900	970	2096
045*	EQHB	2400	2752	2300	1270	2696
045**	EQHB	1700	2752	1600	1270	2696
047	EQHB	2300	2152	2200	970	2096
050	EQHB	2300	2152	2200	1120	2396
054*	EQHB	2600	2752	2500	1270	2696
054**	EQHB	2000	2752	1900	1270	2696
056*	EQHB	3000	3352	2900	1570	3296
063*	EQHB	2600	2752	2500	1270	2696
063**	EQHB	2300	2752	2200	1270	2696
068*	EQHB	3000	3352	2900	1570	3296
072	EQHB	2600	2752	2500	1270	2696
079*	EQHB	3000	3352	2900	1570	3296
090*	EQHB	3300	3352	3200	1570	3296

*) Only EQRA, B-rotor

**) Only EQRC Cube

Dimensions and weights (mm and kg)

EQEE Air heater for hot water

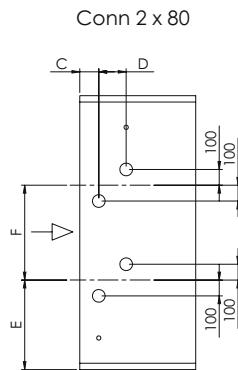
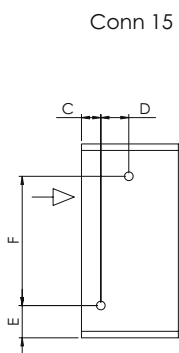
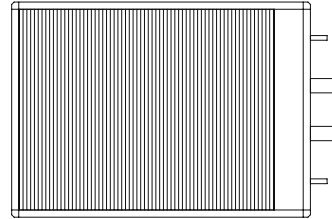
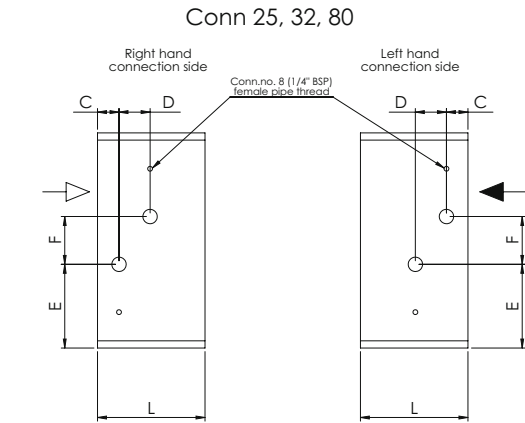

Unit size	b=1	b=2	b=3
005	200	250	250
008	200	250	250
011	200	250	250
009, 014, 018	200	250	250
023	200	250	300
032	200	250	300
020, 027, 041, 047	200	250	300
050	250	300	300
036, 045, 054, 063, 072	250	300	300
056, 068, 079, 090	250	300	300

Length, mm

Output variant	CC dim. manifolds D				
	DN15	DN25	DN32	DN50	DN80
1	0	36	43	68*	-
2	29	58	58	68*	-
3	-	58	58	68*	94

*] with copper tubes 58 mm

Dimensions and weights (mm and kg)

EQEE Air heater for hot water

Unit size	Int. height	Coil height	Output var. / Tube rows	15		25		32		50		80		2x80		
				WV	D	WV	D	WV	D	WV	D	WV	D	WV	D	
005	370	300	1	6->	0	2-4	36									
			2	10->	29	4-8	58	2	43							
			3			4-12	58	2	58							
008	470	400	1	6->	0	2-4	36									
			2	12->	29	4-10	58	2	58							
			3			6-16	58	2-4	58							
011	570	500	1	8->	0	2-6	36									
			2			4-14	58			2	68*					
			3			6-20	58	4	58	2	68*					
009, 014, 018	670	600	1	10->	0	4-8	36	2	43							
			2			6-16	58	4	58	2	68*					
			3			8-24	58	4-6	58	2	68*					
023	820	733	1	12->	0	4-10	36	2	43							
			2			6-20	58	4	58	2	68*					
			3			8-30	58	6	58	4	68*	2	94			
032	920	833	1	12->	0	4-10	36	2	43							
			2			6-22	58	4	58	2	68*					
			3			10-34	58	6-8	58	4	68*	2	94			
020, 027, 041, 047	970	900	1			4-12	36	2	43							
			2			8-26	58	4-6	58	2	68*					
			3			10-38	58	6-8	58	4	68*	2	94			
050	1120	1033	1			4-14	36			2	68*					
			2			8-28	58	6	58	4	68*	2	94			
			3			12-44	58	8-10	58	4-6	68*	2	94			
036, 045, 054, 063, 072	1270	1200	1			6-16	36	4	43	2	68*					
			2			10-34	58	6-8	58	4	68*	2	94			
			3					8-12	58	4-6	68*	2	94			
056, 068, 079, 090	1570	1500	1			6-22	36	4	43	2	68*					
			2			12-44	58	8-10	58	4-6	68*	2	94			
			3					10-16	58	6-8	68*	4	94	2	94	

*) Copper tubes 58 mm

Dimensions and weights (mm and kg)

EQEE Air heater for hot water

Unit size	E	F
005	178	120 233 1RR/250 2RR
008	228	120 333 1RR/350 2RR Conn. 15
011	238	200 433 Conn. 15
009, 014, 018	288	200 533 Conn. 15
023	363	200 666 Conn. 15
032	413	200 766 Conn. 15
020, 027, 041, 047	438	200
050	513	200
036, 045, 063, 072	588	200
056, 068, 079, 090	738	200 750 Conn (2x80)

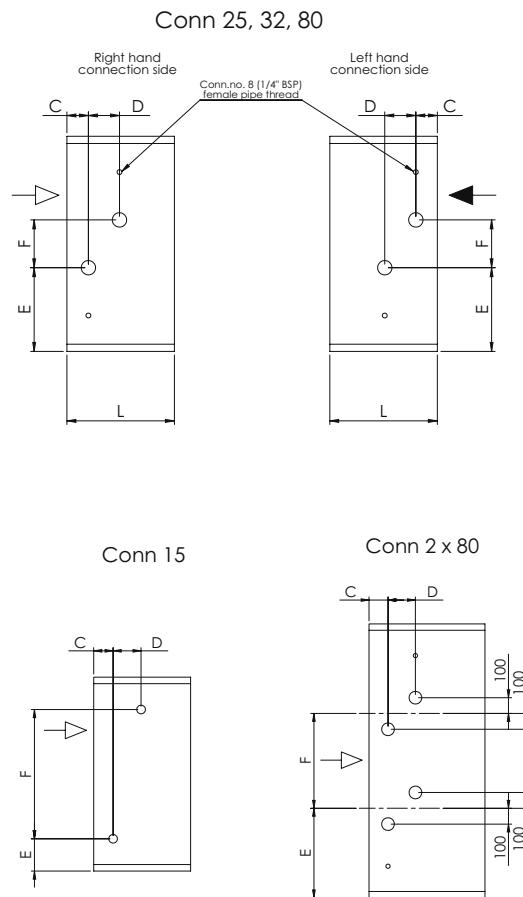
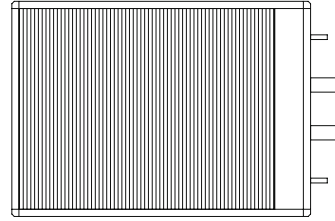

Dimensions and weights (mm and kg)

EQKK Electric air heater, mounted in duct work

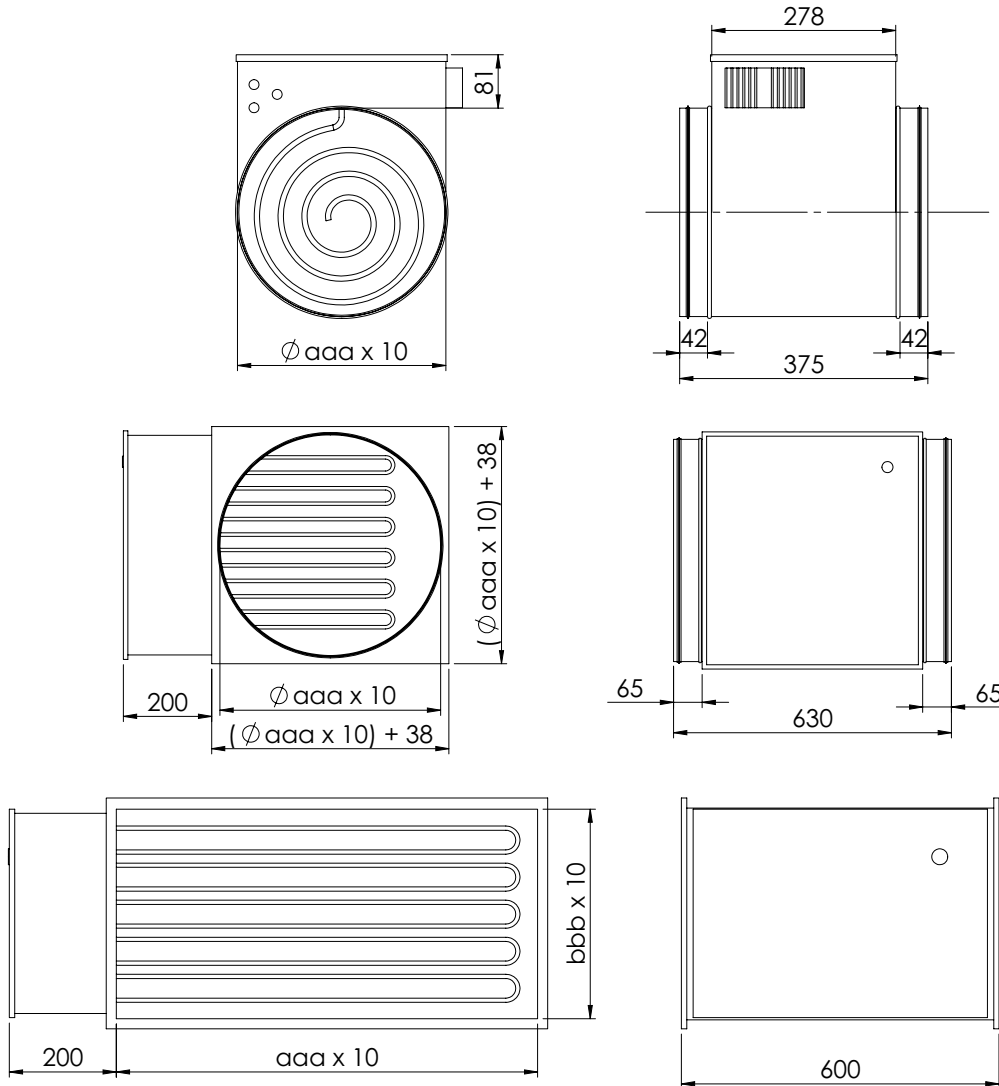

Size		Output variant	Weight, kg	
aaa	bbb		3x230V	3x400V
031	-	1	6	6
031	-	2	7	7
031	-	3	9	9
040	-	1	8	8
040	-	2	9	9
040	-	3	32	30
050	-	1	36	35
050	-	2	39	37
050	-	3	43	40
080	040	1	35	33
080	040	2	39	35
080	040	3	42	39

Size		Output variant	Weight, kg	
aaa	bbb		3x230V	3x400V
110	050	1	47	43
110	050	2	54	52
110	050	3	61	56
140	060	1	55	53
140	060	2	65	64
140	060	3	76	70
140	080	1	65	63
140	080	2	76	72
140	080	3	90	85

Dimensions and weights (mm and kg)

EQEG Frost coil

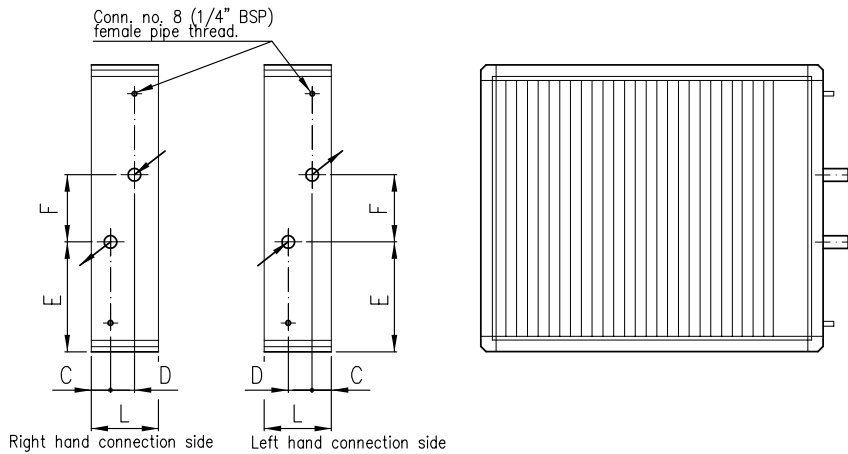

Size	L	Weight, kg Cu/Al	Pipe connection size	Volume, litre	C	D	E	F
005	200	14	15	1	70	36	178	120
008	200	20	15	2	70	36	188	200
009	200	20	15	2	70	36	288	200
011	200	24	25	3	70	36	238	200
014	200	24	25	3	70	36	288	200
018	200	28	25	4	70	43	288	200
020	200	32	25	4	70	36	438	200
023	200	38	25	5	70	43	363	200
027	200	39	25	5	70	43	438	200
032	200	46	25	6	70	43	413	200
036	200	48	25	7	70	43	588	200
041	200	52	25	7	70	43	438	200
045	200	57	25	10	70	43	588	200
050	200	64	25	10	70	43	513	200
054	200	66	32	11	70	43	588	200
056	200	67	32	12	70	43	738	200
063	200	72	32	12	70	43	588	200
068	200	77	32	14	70	43	738	200
072	200	78	32	14	70	43	588	200
079	200	84	32	15	70	43	738	200
090	200	95	32	21	70	43	738	200

Dimensions and weights (mm and kg)

EQEK Air heater, electric

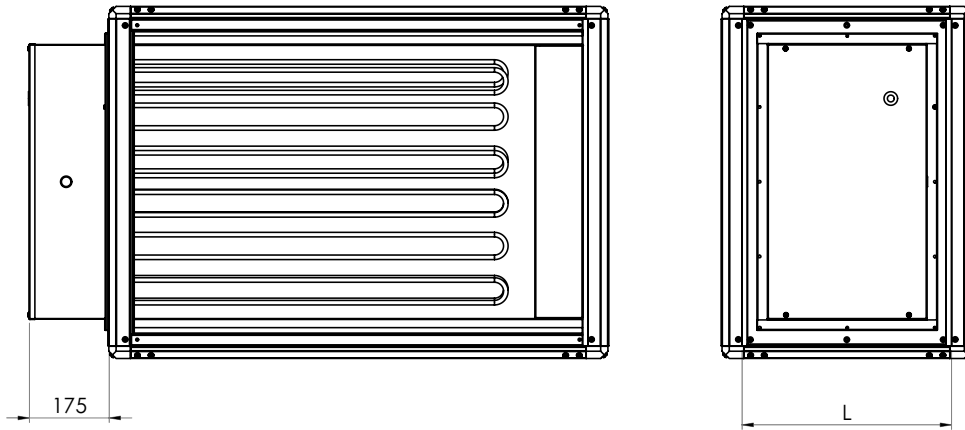

For dimensions, weight and power see product selection tool ACON.

Dimensions and weights (mm and kg)

EQNN Air cooler for chilled water

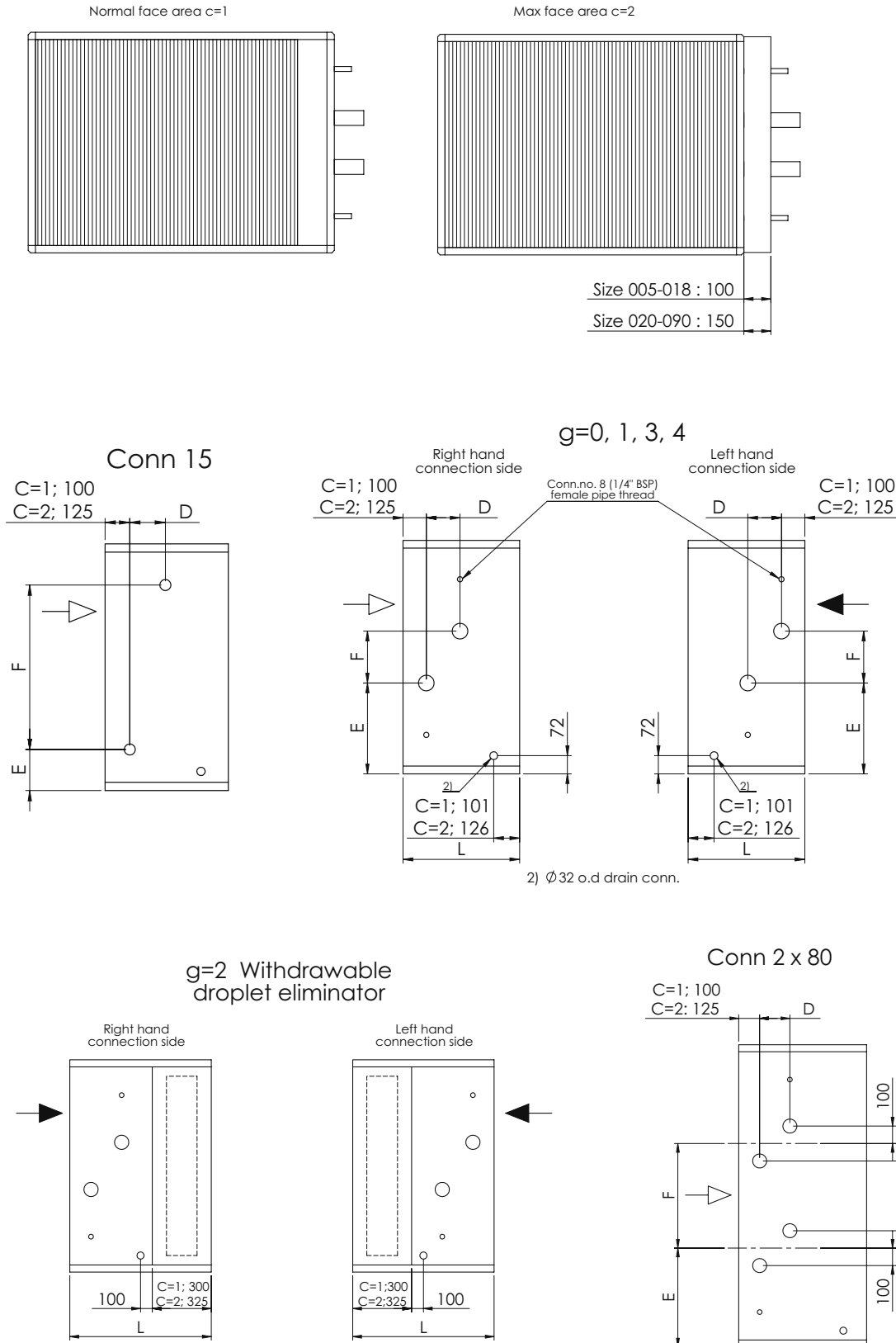

Dimensions and weights (mm and kg)

EQNN Air cooler for chilled water

Unit size	E	F	Out-put. var.	Connection dimensions at different number of VV and dimension D between connetions											
				15		25		32		50		80		2x80	
				VV	D	VV	D	VV	D	VV	D	VV	D	VV	D
005	191 109 Conn. 15	120 283 Conn. 15	2	10->	29	4-8	58	2	58						
			3	16->	29	4-14	58			2	68*				
			4			6-16	87	4	87						
			6			8-26	144	4-6	144		144				
			8			10-34	205	6-8	205	4	205				
008	201 109 Conn. 15	200 109 Conn. 15	2	12->	29	4-10	58	2	58						
			3			6-16	58	4	58	2	68*				
			4			6-22	87	4	87						
			6			10-34	144	6-8	144	4	144				
			8			12-46	205	8-10	205	4-6	205				
011	251	200	2			4-14	58	2	58						
			3			6-22	58	4	58	2	68*				
			4			8-28	87	6	87	4	87				
			6			12-44	144	8-10	144	4-6	144				
			8			16-58	205	10-14	205	6-8	205	2-4	205		
009 014 018	301	200	2			6-16	58	4	58	2	68*				
			3			8-26	58	4-6	58	2	68*				
			4			10-34	87	6-8	87	4	87				
			6			14-52	144	8-12	144	4-6	144				
			8			18-70	205	12-16	205	6-10	205	4	205		
023	368	200	2			6-22	58	4	58	2	68*				
			3			10-32	58	6-8	58	4	68*	2	94		
			4			12-44	87	8-10	87	4-6	87				
			6			18-66	144	10-16	144	6-8	144	2-4	144		
			8					14-22	205	8-12	205	4-6	205		
032	418	200	2			8-24	58	4-6	58	2	68*	2	94		
			3			10-36	58	6-8	58	4	68*				
			4			14-50	87	8-12	87	4-6	87				
			6					12-18	144	6-10	144	4	144		
			8					16-24	205	8-14	205	4-6	205		
020 027 041 047	451	200	2			8-26	58	4-6	58	2	68*				
			3			12-40	58	6-10	58	4	68*	2	94		
			4			14-52	87	8-12	87	4-6	87				
			6					12-20	144	6-10	144	4	144		
			8					16-26	205	8-14	205	4-6	205		
050	518	200	2			8-30	58	6	58	4	68*	2	94		
			3			12-46	58	8-10	58	4-6	68*	2	94		
			4			16-62	87	10-14	87	6-8	87	2-4	101**		
			6					14-22	144	8-12	144	4-6	144		
			8					18-30	205	10-16	205	4-8	205		
036 045 054 063 072	584 384 Conn. (2x80)	200 600 Conn. (2x80)	2			10-34	58	6-8	58	4	68*	2	94		
			3					8-12	58	4-6	68*	2	94		
			4					12-16	87	6-10	87	4	101**		
			6					16-26	144	8-14	144	4-6	144		
			8							12-20	205	6-10	205	2-4	205
056 068 079 090	751 468 Conn. (2x80)	200 766 Conn. (2x80)	2			12-44	58	8-10	58	4-6	68*	2	94		
			3					10-16	58	6-8	68*	4	94	2	94
			4					14-22	87	8-12	87	4-6	101**		
			6							10-18	144	6-8	144	2-4	144
			8							14-24	205	6-12	205	4	205
10							18-32	263	8-16	263					

*] With copper tubes 58 mm

**] 101 mm for connection but 87 mm for nipple

Dimensions and weights (mm and kg)

EQNP Air cooler for evaporative refrigerant

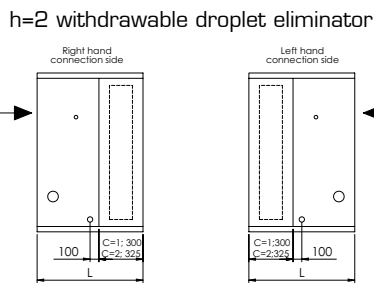
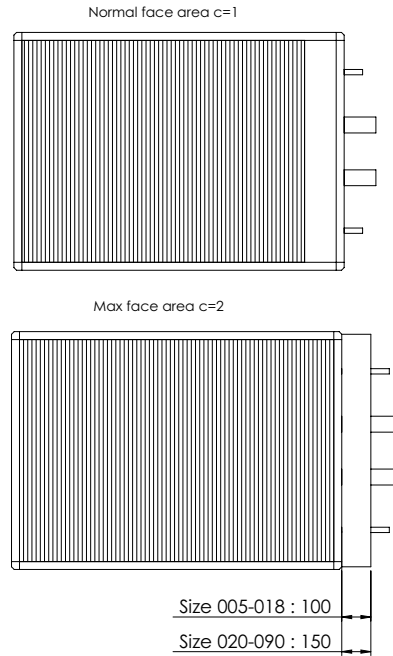
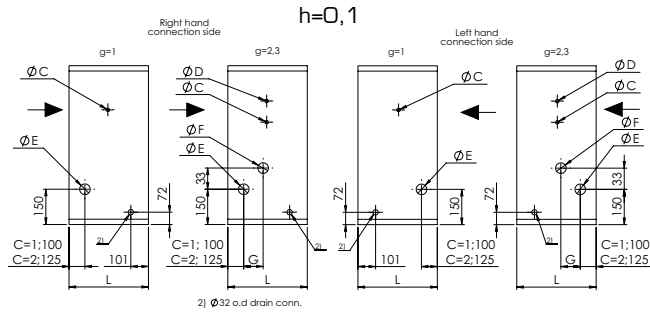

Size	Output variant b=2							Output variant b=3						
	ØC	ØD	ØE	ØF	G	Volume litre	Weight kg	ØC	ØD	ØE	ØF	G	Volume litre	Weight kg
005	15,9	15,9	28,6	28,6	29	3	23	15,9	15,9	28,6	28,6	29	4	26
008	22	15,9	34,9	28,6	34	3	32	15,9	15,9	28,6	28,6	29	5	36
009	15,9	15,9	28,6	28,6	29	4	28	22	15,9	28,6	28,6	29	4	32
011	15,9	15,9	28,6	28,6	29	5	36	15,9	15,9	28,6	28,6	29	7	42
014	15,9	15,9	28,6	28,6	29	5	37	22	15,9	28,6	28,6	29	7	43
018	22	15,9	28,6	34,9	34	6	44	22	15,9	28,6	28,6	29	9	52
020	22	15,9	34,9	28,6	34	6	49	22	15,9	34,9	28,6	34	10	57
023	22	15,9	34,9	28,6	34	9	65	22	15,9	34,9	28,6	34	13	76
027	22	15,9	34,9	28,6	34	19	59	22	22	41,3	28,6	38	13	70
032	22	15,9	34,9	28,6	34	11	73	22	41,3	41,3	28,6	38	16	87
036	22	22	41,3	28,6	38	11	70	22	22	41,3	28,6	38	16	84
041	22	15,9	34,9	28,6	34	13	85	22	15,9	34,9	28,6	34	19	102
045	22	22	41,3	28,6	38	13	86	22	22	41,3	28,6	38	20	103
050	22	15,9	41,3	28,6	38	17	104	22	15,9	41,3	28,6	38	25	125
054	22	22	41,3	28,6	38	16	103	22	22	41,3	28,6	38	24	123
056	22	22	41,3	34,9	40	17	105	22	22	41,3	34,9	40	26	126
063	22	22	41,3	28,6	38	19	112	22	22	41,3	28,6	38	28	136
068	22	22	41,3	34,9	40	21	119	22	22	41,3	34,9	40	31	145
072	22	22	41,3	28,6	38	22	124	22	22	41,3	28,6	38	32	151
079	22	22	41,3	34,9	40	24	132	22	22	41,3	34,9	40	36	161
090	22	22	41,3	34,9	40	28	144	22	22	41,3	34,9	40	41	178

Output variant bb	L	
	h=0.1	h=2
02	400	500
03	400	500
04	500	500

Output variant bb	L	
	h=0.1	h=2
06	500	600
08	500	600

Dimensions and weights (mm and kg)

EQNP Air cooler for evaporative refrigerant

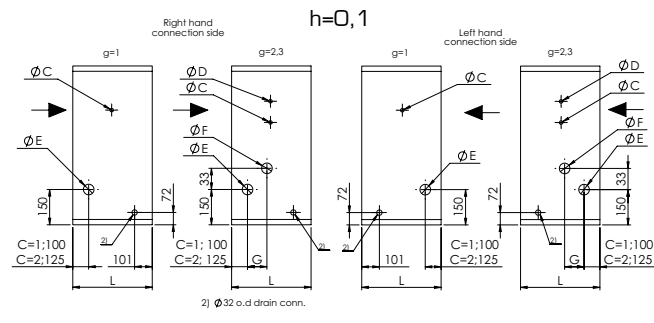

h=2 withdrawable droplet eliminator

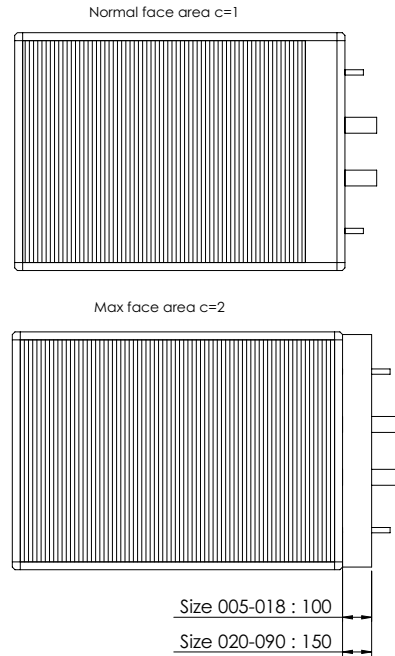
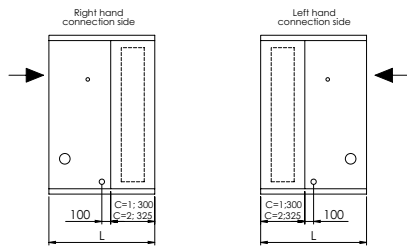

Size	Output variant b=4							Output variant b=6						
	ØC	ØD	ØE	ØF	G	Volume litre	Weight kg	ØC	ØD	ØE	ØF	G	Volume litre	Weight kg
005	15,9	15,9	28,6	28,6	29	5	29	22	22	15,9	28,6	29	6	35
008	15,9	15,9	28,6	28,6	29	7	41	22	15,9	28,6	28,6	29	9	50
009	22	15,9	28,6	28,6	29	4	36	22	15,9	34,9	28,6	34	9	46
011	22	15,9	34,9	28,6	34	8	49	22	15,9	34,9	28,6	34	13	61
014	22	15,9	34,9	28,6	34	9	50	22	15,9	34,9	28,6	34	13	62
018	22	15,9	34,9	28,6	34	12	61	22	15,9	34,9	28,6	34	17	77
020	22	22	41,3	28,6	38	13	66	22	22	41,3	34,9	38	19	83
023	22	15,9	34,9	28,6	34	17	88	22	22	41,3	28,6	34	26	111
027	22	22	41,3	28,6	38	17	81	22	22	41,3	34,9	38	26	104
032	22	41,3	28,6	28,6	29	21	100	22	22	41,3	28,6	38	32	128
036	22	22	41,3	34,9	40	22	98	22	22	54	34,9	50	32	130
041	22	22	41,3	28,6	38	25	118	22	22	41,3	34,9	40	38	150
045	22	22	41,3	34,9	40	27	120	22	22	54	34,9	50	40	159
050	22	22	41,3	34,9	38	34	146	22	22	41,3	34,9	40	50	189
054	22	22	41,3	34,9	38	32	144	22	22	54	34,9	50	48	189
056	22	22	54	34,9	50	34	153	22	22	54	41,3	50	52	196
063	22	22	41,3	34,9	40	38	160	22	22	54	34,9	50	57	212
068	22	22	54	34,9	50	55	217	22	22	54	41,3	50	62	227
072	22	22	41,3	34,9	40	43	178	22	22	54	34,9	50	65	237
079	22	22	54	34,9	50	48	196	22	22	54	41,3	50	72	256
090	22	22	54	34,9	50	55	217	22	22	54	41,3	50	83	285

Output variant bb	L	
	h=0,1	h=2
02	400	500
03	400	500
04	500	500

Output variant bb	L	
	h=0,1	h=2
06	500	600
08	500	600

Dimensions and weights (mm and kg)

EQNP Air cooler for evaporative refrigerant

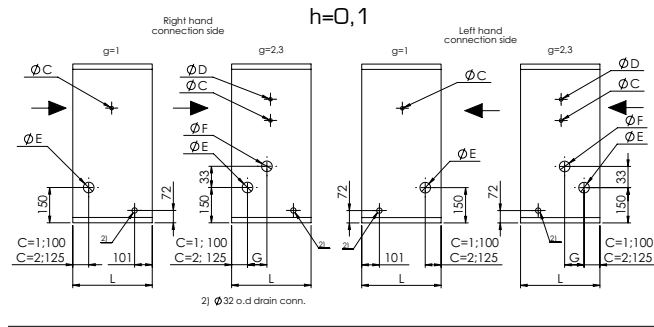

h=2 withdrawable droplet eliminator

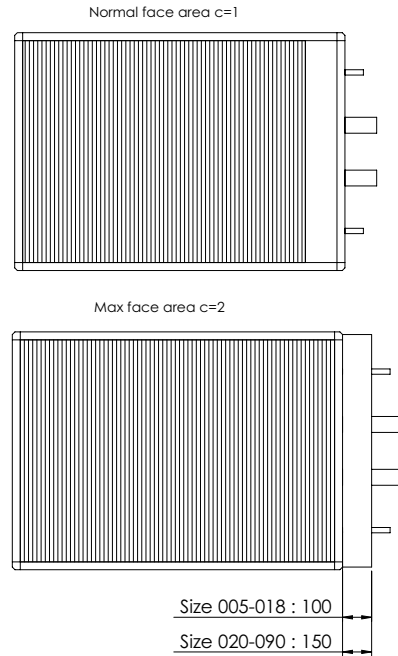
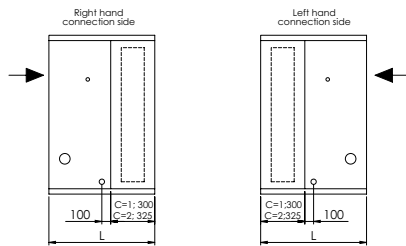

Output variant b=8							
Size	ØC	ØD	ØE	ØF	G	Volume litre	Weight kg
005	22	15,9	34,9	28,6	34	8	41
008	22	15,9	34,9	28,6	34	12	60
009	22	15,9	34,9	28,6	34	12	54
011	22	15,9	34,9	28,6	34	17	73
014	22	15,9	34,9	28,6	34	17	74
018	22	15,9	34,9	28,6	34	23	93
020	22	22	41,3	34,9	40	26	100
023	22	22	41,3	28,6	34	35	134
027	22	22	41,3	34,9	40	34	126
032	22	22	41,3	34,9	40	42	155
036	22	22	54	34,9	50	43	157
041	22	22	41,3	34,9	40	50	183
045	22	22	54	34,9	50	54	193
050	22	22	54	34,9	50	67	235
054	22	22	54	34,9	50	65	230
056	22	22	54	41,3	50	69	239
063	22	22	54	34,9	50	75	259
068	22	22	54	41,3	50	83	278
072	22	22	54	34,9	50	86	291
079	22	22	54	41,3	50	96	315
090	22	22	54	41,3	50	110	353

Output variant bb	L	
	h=0,1	h=2
02	400	500
03	400	500
04	500	500

Output variant bb	L	
	h=0,1	h=2
06	500	600
08	500	600



Dimensions and weights (mm and kg)

EQHN Air cooler in hygienic design, c=1

Normal face area c=1
(withdrawable drain tray)

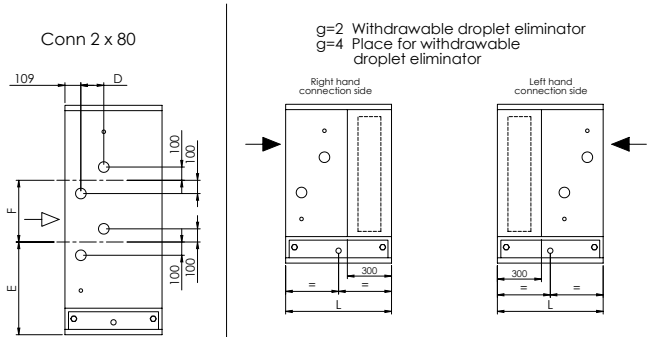
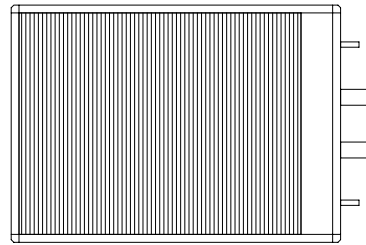
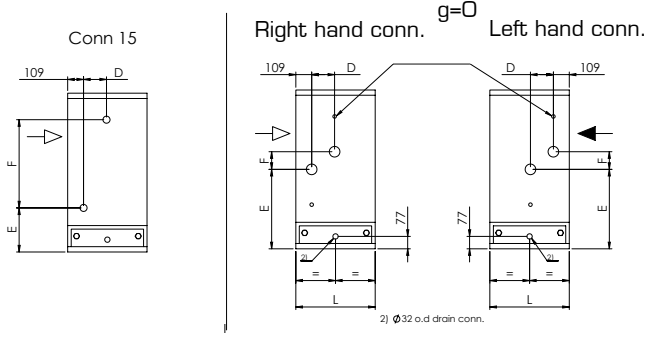

Output variant	L	
	g=0	g=2, 4
02	350	700
03	350	700
04	350	700
06	450	700
08	500	750
10	550	800



Dimensions and weights (mm and kg)

EQHN Air cooler in hygienic design, c=1

Unit size	E	F	Out-put var	Connection dimensions at different number of VV and dimension D between connetions											
				15		25		32		50		80		2x80	
				VV	D	VV	D	VV	D	VV	D	VV	D	VV	D
008	283	120	2	10->	29	4-8	58	2	58						
			3			4-14	58			2	68*				
			4			6-16	87	4	87						
			6			8-26	144	4-6	144						
			8			10-34	205	6-8	205	4	205				
			10			12-44	263	8-10	263						
011	293	200	2			4-10	58	2	58						
			3			6-16	58	4	58	2	68*				
			4			6-22	87	4	87						
			6			10-34	144	6-8	144	4	144				
			8			12-46	205	8-10	205	4-6	205				
			10			16-58	263	10-14	263	6-8	263				
009, 014, 018	343	200	2			4-14	58	2	58						
			3			6-22	58	4	58	2	68*				
			4			8-28	87	6	87	4	87				
			6			12-44	144	8-10	144	4-6	144				
			8			16-58	205	10-14	205	6-8	205	2-4	205		
			10			20-74	263	12-18	263	6-10	263				
023	410	200	2			6-18	58	4	58	2	68*				
			3			8-28	58	6	58	4	68*	2	94		
			4			10-14	87	6-8	87	4	87				
			6			16-56	144	10-14	144	6-8	144	2-4	144		
			8					12-18	205	6-10	205	4	205		
			10			24-94	263	14-22	263	8-12	263				
032	460	200	2			6-22	58	4	58	2	68*				
			3			10-32	58	6-8	58	4	68*	2	94		
			4			12-44	87	8-10	87	4-6	87				
			6			18-66	144	10-16	144	6-8	144	2-4	144		
			8					14-22	205	8-12	205	4-6	205		
			10					16-26	263	8-14	263				
020, 027, 041, 047	493	200	2			8-24	58	4-6	58	2	68*				
			3			10-36	58	6-8	58	4	68*	2	94		
			4			14-40	87	8-12	87	4-6	87				
			6			20-72	144	12-18	144	6-10	144	4	144		
			8					14-24	205	8-12	205	4-6	205		
			10					18-30	263	10-16	263	4-8	263		
050	560	200	2			8-28	58	6	58	4	68*	2	94		
			3			12-42	58	8-10	58	4-6	68*	2	94		
			4			16-56	87	10-14	87	6-8	87	2-4	101**		
			6					14-20	144	8-12	144	4-6	144		
			8					12-28	205	10-16	205	4-8	205		
			10					24-34	263	12-20	263	4-10	263		
036, 045, 054, 063, 072	643	200	2			10-32	58	6-8	58	4	68*	2	94		
			3					8-12	58	4-6	68*	2	94		
			4			18-66	58	10-16	87	6-8	87	4	101**		
			6					16-24	144	6-14	144	4-6	144		
			8							10-18	205	6-8	205	2-4	205
			10					24-40	263	12-22	263	6-10	263		
056, 068, 079, 090	793	200	2			12-42	58	8-10	58	4-6	68*	2	94		
			3					10-14	58	6-8	68*	2-4	94		
			4					14-20	87	8-12	87	4-6	101**		
			6							10-18	144	4-8	144		
			8							14-24	205	6-12	205	4	205
			10					16-30	263	8-14	263				

*) With copper tubes 58 mm

**)101 mm for connection but 87 mm for nipple



Dimensions and weights (mm and kg)

EQHN Air cooler in hygienic design, c=2

Normal face area c=2
(non-withdrawable drain tray)

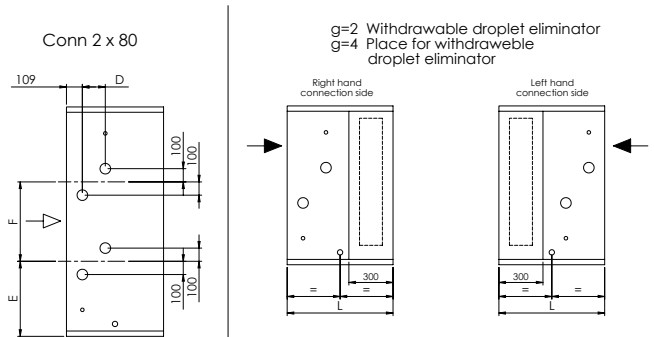
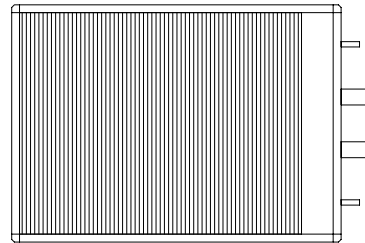
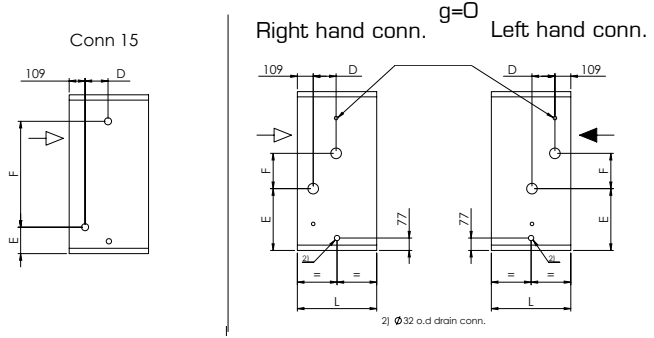

Output variant	L	
	g=0	g=2, 4
02	350	700
03	350	700
04	350	700
06	450	700
08	500	750
10	550	800



Dimensions and weights (mm and kg)

EQHN Air cooler in hygienic design, c=2

Unit size	E	F	Out-put var	Connection dimensions at different number of VV and dimension D between connetions														
				15		25		32		50		80		2x80				
				VV	D	VV	D	VV	D	VV	D	VV	D	VV	D			
008	267	120	2		4-10	58	2	58										
			3		4-14	58			2	68*								
			4		6-20	87	4	87	2	87								
			6		8-30	144	6	144	4	144								
			8		12-40	205	6-10	205	4	205								
		10		12-50	263	8-12	263											
011	277	200	2		4-12	58	2	58										
			3		6-18	58	4	58	2	68*								
			4		6-26	87	4-6	87										
			6		10-38	144	6-8	144	4	144								
			8		14-52	205	8-12	205	4-6	205								
		10		18-64	263	10-16	263	6-8	263									
009, 014, 018	327	200	2		6-16	58	4	58	2	68*								
			3		8-24	58	4-6	58	2	68*								
			4		10-32	87	6-8	87	4	87								
			6		14-48	144	8-12	144	4-6	144								
			8		18-64	205	10-16	205	6-8	205	2-4	205						
		10		22-80	263	12-20	263	6-10	263									
023	393	200	2		6-20	58	4	58	2	68*								
			3		8-30	58	6	58	4	68*	2	94						
			4		12-40	87	6-10	87	4	87	2	101**						
			6		16-60	144	10-14	144	6-8	144	2-4	144						
			8				12-22	205	6-10	205	4	205						
		10				16-24	263	8-14	263									
032	443	200	2		6-22	58	4	58	2	68*								
			3		10-34	58	6-8	58	4	68*	2	94						
			4		12-46	87	8-10	87	4-6	87								
			6		18-68	144	10-16	144	6-8	144	4	144						
			8				14-22	205	8-12	205	4-6	205						
		10				18-28	263	10-16	263	4-8	263							
020, 027, 041, 047	477	200	2		8-24	58	4-6	58	2	68*								
			3		10-36	58	6-8	58	4	68*	2	94						
			4		14-50	87	8-12	87	4-6	87								
			6				12-18	144	6-10	144	4	144						
			8				16-24	205	8-14	205	4-6	205						
		10				18-30	263	10-16	263	4-8	263							
050	543	200	2		8-28	58	6	58	4	68*	2	94						
			3		12-42	58	8-10	58	4-6	68*	2	94						
			4		16-58	87	10-14	87	6-8	87	2-4	101**						
			6				14-20	144	8-12	144	4-6	144						
			8				18-28	205	10-16	205	4-8	205						
		10				22-36	263	12-20	263									
036, 045, 054, 063, 072	627	200	2		8-34	58	6	58	4	68*	2	94						
			3				8-12	58	4-6	68*	2	94						
			4		18-68	87	10-16	87	6-8	87	4	101**						
			6				16-24	144	8-14	144	4-6	144						
			8						10-18	205	4-8	205						
		10				24-42	263	14-22	263	6-12	263							
056, 068, 079, 090	777	200	2		12-42	58	8-10	58	4-6	68*	2	94						
			3				10-16	58	6-8	68*	2-4	94						
			4				14-20	87	8-12	87	4-6	101**						
			6						10-18	144	4-8	144						
			8						14-24	205	6-12	205	4	205				
		10						16-30	263	8-14	263							

*) With copper tubes 58 mm

**) 101 mm for connection but 87 mm for nipple

Dimensions and weights (mm and kg)

EQLK Plenum fan Centriflow Plus®

e=1

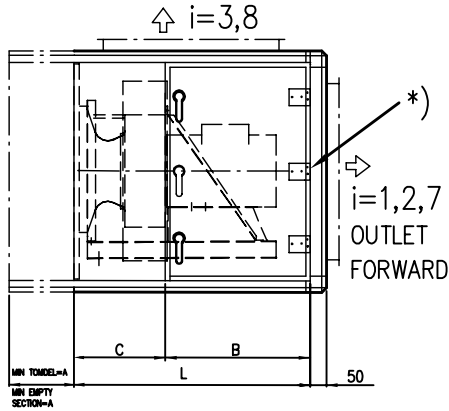

e=2

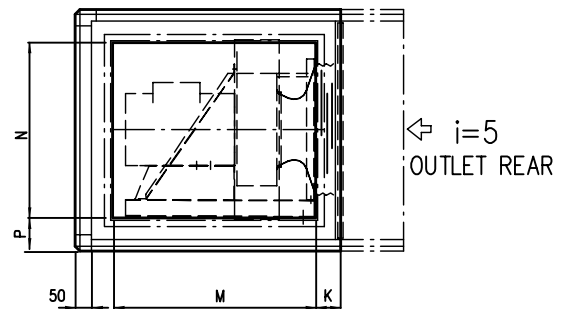
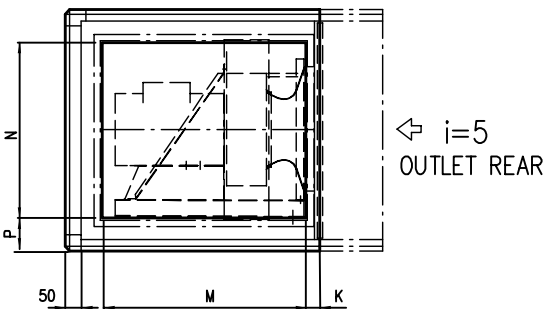
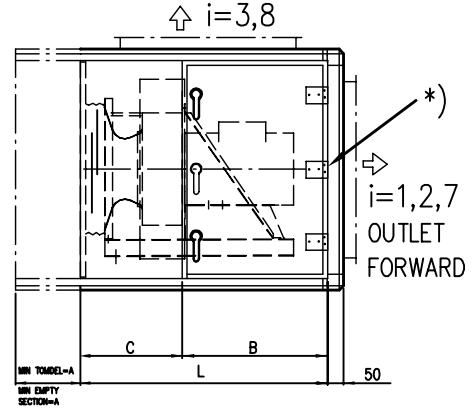

Unit size		Fan size	D	E	G	i=8	
aaa	b					e=1 H	e=2 H
005	2	025	400	Ø315	-	275	375
008	2	028	550	Ø400	-	275	375
	3	031				300	400
009	2	028	400	Ø500	-	275	375
	3	031				300	400

Dimensions and weights (mm and kg)

EQLK Plenum fan Centriflow Plus®

e=1

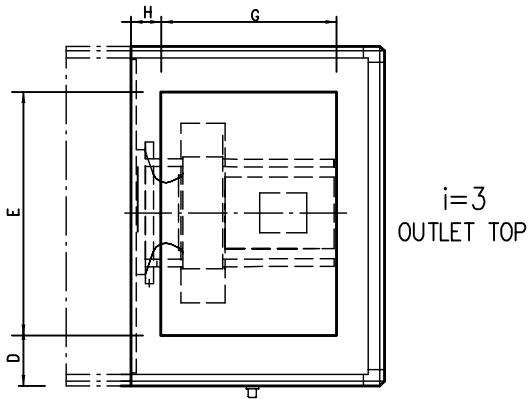

e=2

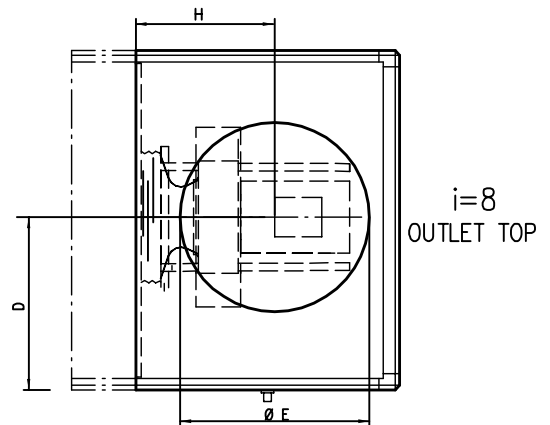
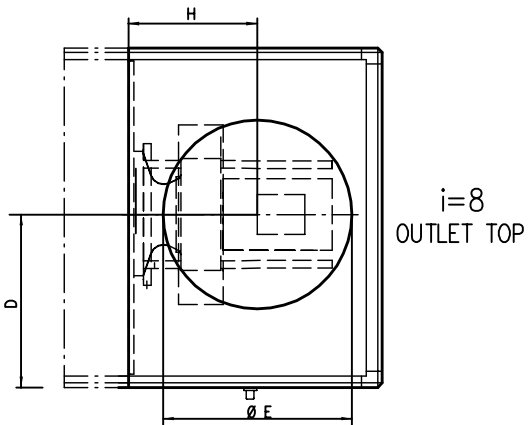
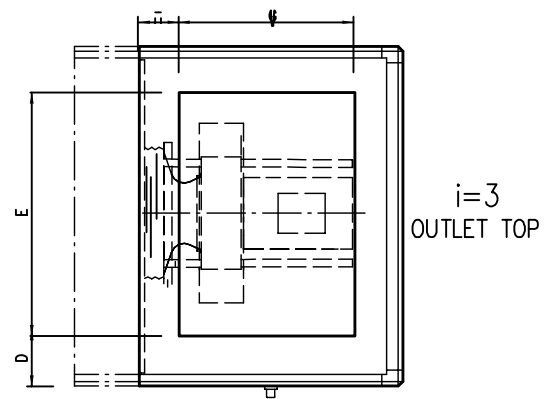

Dimensions and weights (mm and kg)

EQLK Plenum fan Centriflow Plus®

			Empty section	Door	Door	Panel	Panel	i=3							
Size aaa	b	Fan size	A	e=1 B	e=2 B	e=1 C	e=2 C	D	E	G	e=1 H	e=2 H	e=1 L	e=2 L	Weight
005	2	025	50	400	400	150	250	185	500	300	100	200	550	650	23
008	2	028	100	400	400	150	250	185	800	400	100	200	550	650	32
	3	031	100	400	400	200	300						600	700	34
009	2	028	100	400	400	150	250	185	500	400	100	200	550	650	30
	3	031	100	400	400	200	300						600	700	32
011	2	035	100	400	400	250	350	200	800	400	100	200	650	750	48
	3	040	100	400	500	300	300						700	800	50
014	2	035	200	400	500	300	300	185	800	500	100	200	700	800	48
	3	040	200	400	500	300	300						700	800	50
018	2	040	200	400	500	300	300	185	1100	500	100	200	700	800	56
	3	045	200	450	550	300	300						750	850	66
020	2	040	200	400	500	300	300	185	800	600	50	150	700	800	54
	3	045	200	450	550	300	300				75	175	750	850	64
023	2	050	200	500	600	350	350	185	1400	600	100	200	850	950	79
	3	056	200	600	700	300	300						900	1000	95
027	2	050	250	500	600	350	350	185	1100	600	100	200	850	950	79
	3	056	300	600	700	300	300				150	250	900	1000	94
032	2	056	300	600	700	300	300	200	1400	800	50	150	900	1000	98
	3	063	300	600	700	350	350				75	175	950	1050	109
036	2	056	300	600	700	300	300	185	1100	800	50	150	900	1000	99
	3	063	300	600	700	350	350				75	175	950	1050	109
041	2	063	300	600	700	350	350	185	1700	800	75	175	950	1050	115
	3	071	350	600	700	400	400				100	200	1000	1100	134
045	2	063	300	600	700	450	450	185	1400	800	150	250	1050	1150	114
	3	071	400	600	700	550	550				1150	1250	129		
050	2	071	300	600	700	550	550	185	2000	800	150	250	1150	1250	140
	3	080	300	700	700	500	600				200	300	1200	1300	155
054	2	071	400	600	700	550	550	185	1700	1000	75	175	1150	1250	138
	3	080	400	700	700	500	600				100	200	1200	1300	152
056	2	071	400	600	700	550	550	185	1400	1000	75	175	1150	1250	135
	3	080	400	700	700	500	600				100	200	1200	1300	150
063	2	071	400	600	700	550	550	185	2000	1000	100	200	1150	1250	156
	3	080	400	700	700	500	600				1200	1300	157		
068	2	080	400	700	700	550	550	185	1700	1000	100	200	1200	1300	159
	3	090	400	700	700	500	600				1200	1300	193		
072	2	071	400	600	700	550	550	200	2200	1000	75	175	1150	1250	152
	3	080	400	700	700	500	600				100	200	1200	1300	165
079	2	080	400	700	700	500	600	185	2000	1000	100	200	1200	1300	203
	3	090	400	700	700	750	850				200	300	1400	1500	241
090	2	090	400	700	700	750	850	200	2200	1200	100	200	1400	1500	211
	3	100	400	700	700	850	950				1450	1550	253		

e=1 Rubber anti vibration

e=2 Steel spring anti vibration

Dimensions and weights (mm and kg)

EQLK Plenum fan Centriflow Plus®

			Empty section	Door	Door	Panel	Panel	i=5							Weight
Size aaa	b	Fan size	A	e=1 B	e=2 B	e=1 C	e=2 C	P	N	M	e=1 K	e=2 K	e=1 L	e=2 L	
005	2	025	50	400	400	150	250	88	300	400	75	175	550	650	23
008	2	028	100	400	400	150	250	88	400	400	75	175	550	650	32
	3	031	100	400	400	200	300						600	700	34
009	2	028	100	400	400	150	250	88	600	400	75	175	550	650	30
	3	031	100	400	400	200	300						600	700	32
011	2	035	100	400	400	250	350	88	500	500	75	175	650	750	48
	3	040	100	400	500	300	300						700	800	50
014	2	035	200	400	500	300	300	88	600	600	50	150	700	800	48
	3	040	200	400	500	300	300						700	800	50
018	2	040	200	400	500	300	300	88	600	600	50	150	700	800	56
	3	045	200	450	550	300	300				75	175	750	850	66
020	2	040	200	400	500	300	300	138	800	600	50	150	700	800	54
	3	045	200	450	550	300	300				75	175	750	850	64
023	2	050	200	500	600	350	350	163	600	600	100	200	850	950	79
	3	056	200	600	700	300	300						900	1000	95
027	2	050	250	500	600	350	350	138	800	600	100	200	850	950	79
	3	056	300	600	700	300	300						900	1000	94
032	2	056	300	600	700	300	300	113	800	800	50	150	900	1000	98
	3	063	300	600	700	350	350				75	175	950	1050	109
036	2	056	300	600	700	300	300	188	1000	800	50	150	900	1000	99
	3	063	300	600	700	350	350				75	175	950	1050	109
041	2	063	300	600	700	350	350	138	1000	800	75	175	950	1050	115
	3	071	350	600	700	400	400				100	200	1000	1100	134
045	2	063	300	600	700	450	450	88	1200	800	100	200	1050	1150	114
	3	071	400	600	700	550	550						1150	1250	129
050	2	071	300	600	700	550	550	113	1000	1000	75	175	1150	1250	140
	3	080	300	700	700	500	600				100	200	1200	1300	155
054	2	071	400	600	700	550	550	88	1200	1000	75	175	1150	1250	138
	3	080	400	700	700	500	600				100	200	1200	1300	152
056	2	071	400	600	700	550	550	138	1400	1000	75	175	1150	1250	135
	3	080	400	700	700	500	600				100	200	1200	1300	150
063	2	071	400	600	700	550	550	88	1200	1000	75	175	1150	1250	156
	3	080	400	700	700	500	600				100	200	1200	1300	157
068	2	080	400	700	700	550	550	138	1400	1000	100	200	1200	1300	159
	3	090	400	700	700	500	600						1350	1450	193
072	2	071	400	600	700	550	550	88	1200	1000	75	175	1150	1250	152
	3	080	400	700	700	500	600				100	200	1200	1300	165
079	2	080	400	700	700	500	600	138	1400	1000	100	200	1200	1300	203
	3	090	400	700	700	750	850						1450	1550	241
090	2	090	400	700	700	750	850	138	1400	1200	100	200	1450	1550	211
	3	100	400	700	700	850	950						1550	1650	253

e=1 Rubber anti.vibration

e=2 Steel spring anti-vibration

Dimensions and weights (mm and kg)

EQLK Plenum fan Centriflow Plus® with EC motor

Unit size		Fan size	Empty section A	Door		Panel		i=3						Weight	
aaa	b			e=1 B	e=2 B	e=1 C	e=2 C	D	E	G	e=1 H	e=2 H	e=1 L		e=2 L
005	2	025	50	450	550	0	0	150	500	300	100	200	450	550	21
008	2	028	50	500	600	0	0	150	800	300	100	200	500	600	28
	3	031	50	500	600	0	0						500	600	29
009	2	028	100	500	600	0	0	150	500	300	100	200	500	600	26
	3	031	100	500	600	0	0						500	600	27
011	2	035	100	550	650	0	0	300	800	400	100	200	550	650	41
	3	040	100	600	700	0	0						600	700	43
014	2	035	150	400	500	300	300	200	800	400	100	200	700	800	40
	3	040	150	400	500	300	300						700	800	42
018	2	040	150	400	500	300	300	200	1100	400	100	200	700	800	49
	3	045	150	-	-	-	-						-	-	-
020	2	040	200	400	500	300	300	200	800	600	50	150	700	800	46
	3	045	200	-	-	-	-						-	-	-
023	2	050	150	-	-	-	-	-	-	-	-	-	-	-	-
027	2	050	250	-	-	-	-	-	-	-	-	-	-	-	-

Unit size		Fan size	Empty section A	Door		Panel		i=5						Weight	
aaa	b			e=1 B	e=2 B	e=1 C	e=2 C	P	N	M	e=1 K	e=2 K	e=1 L		e=2 L
005	2	025	50	450	550	0	0	88	300	300	75	175	450	550	21
008	2	028	50	500	600	0	0	88	400	300	100	200	500	600	28
	3	031	50	500	600	0	0						500	600	29
009	2	028	100	500	600	0	0	88	600	300	100	200	500	600	26
	3	031	100	500	600	0	0						500	600	27
011	2	035	100	550	650	0	0	88	500	400	75	175	550	650	41
	3	040	100	600	700	0	0						600	700	43
014	2	035	150	400	500	300	300	88	600	500	100	200	700	800	40
	3	040	150	400	500	300	300						700	800	42
018	2	040	150	400	500	300	300	88	600	500	100	200	700	800	49
	3	045	150	-	-	-	-						-	-	
020	2	040	200	400	500	300	300	138	800	600	50	150	700	800	46
	3	045	200	-	-	-	-						-	-	
023	2	050	150	-	-	-	-	-	-	-	-	-	-	-	-
027	2	050	250	-	-	-	-	-	-	-	-	-	-	-	-

Unit size		Fan size	i=8						
aaa	b		D	E	G	e=1 H	e=2 H	e=1 L	e=2 L
005	2	025	400	Ø315	-	225	325	450	650
008	2	028	550	Ø400	-	275	375	550	650
	3	031						600	700
009	2	028	400	Ø500	-	275	375	550	650
	3	031						600	700

Dimensions and weights (mm and kg)

EQLR Centrifugal fan, belt driven

- EQAZ-25 Flexible connection
- EQAZ-26 Duct connection piece
- EQAZ-27 Counter-flange
- EQAZ-28 Protective screen

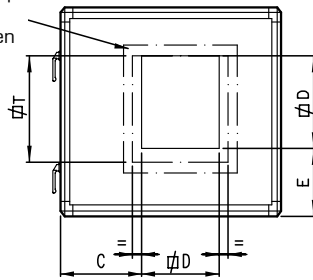

Fan with top inlet
Fan section viewed from above

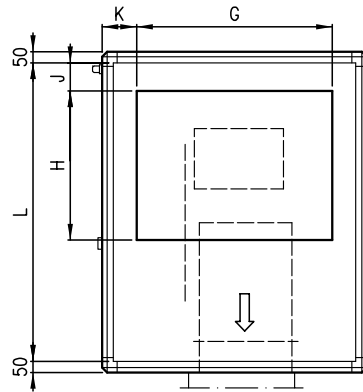

gg=01,02,04,21

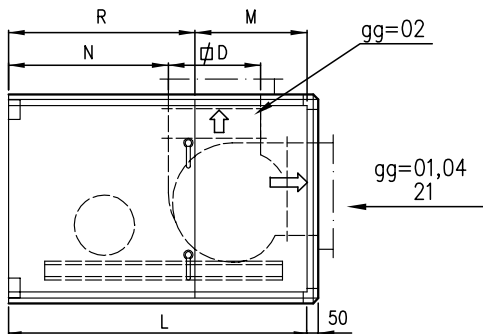

gg=05,06,08,25

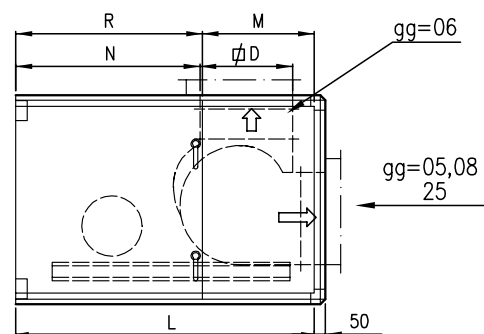

Dimensions and weights (mm and kg)

EQLR Centrifugal fan, belt driven

Size					Outlet forward														Weight
					gg=21,25				gg=01, 21		gg=04		gg=05, 25		gg=08				
aaa	b	Fan size	C	D	G	H	J	K	E*	E**	L	M	L	M	L	M	L	M	
008	3	022	405	290	800	500	100	150	-	112	950	250	1000	300	950	250	1000	300	85
009	2	022	255	290	500	500	100	150	246	112	950	250	1000	300	950	250	1000	300	85
	3	025	240	320					249	105	1000	300	1050	250	1000	300	1000	300	1000
011	2	025	440	320	800	500	100	200	249	105	1000	300	1050	250	1000	300	1000	300	95
014	2-	028	370	360	800	500	100	150	259	95	1050	350	1100	400	1050	350	1050	350	109
	3-	031	348	404					267	113	1100	400	1100	400	1050	350	1100	400	1050
018	2-	031	498	404	800	500	100	300	267	113	1100	400	1100	400	1050	350	1100	400	143
020	2-	031	348	404	800	800	100	150	267	113	1100	400	1100	400	1050	350	1100	400	128
	3	035	323	454					301	115	1300	600	1300	600	1300	600	1350	450	160
023	2s	035	890	454	1100	800	100	300	373	189	1100	400	1100	400	1100	400	1100	400	190
	3	040	598	504					324	123	1400	500	1400	500	1400	500	1400	500	200
027	2	035	473	454	1100	800	100	150	301	115	1300	400	1300	400	1300	400	1350	450	186
	3	040	448	504					324	123	1400	500	1400	500	1400	500	1400	500	200
032	2s	040	917	504	1100	800	100	350	421	189	1150	450	1150	450	1150	450	1150	450	195
	3	045	615	570					356	133	1500	600	1500	600	1500	600	1500	600	225
036	2	040	448	504	1100	1000	100	150	324	123	1400	500	1400	500	1400	500	1400	500	221
	3	045	415	570					346	125	1500	600	1500	600	1500	600	1500	600	225
041	2s	045	970	570	1100	800	100	450	407	183	1200	300	1200	300	1200	300	1200	300	280
	3	050	680	640					367	133	1600	700	1600	700	1600	700	1600	700	300
045	2s	045	820	570	1100	1000	100	300	397	173	1200	300	1200	300	1200	300	1200	300	280
	3	050	530	640					1400	150	367	133	1600	700	1600	700	1600	700	1600
047	2s	045	1120	570	1400	1000	100	450	407	173	1200	300	1200	300	1200	300	1200	300	280
	3	050	830	640					367	133	1600	700	1600	700	1600	700	1600	700	335
050	2s	050	1124	640	1400	1000	100	450	477	251	1300	400	1300	400	1300	400	1300	400	335
	3	056	793	714					406	133	1800	900	1800	900	1800	900	1800	900	425
054	2s	050	974	640	1400	1000	100	300	477	251	1300	400	1300	400	1300	400	1300	400	417
	3s	056	939	714					540	266	1500	600	1500	600	1500	600	1500	600	380
056	2	050	530	640	1400	1200	100	150	367	133	1600	700	1600	700	1600	700	1600	700	313
	3	056	493	714					406	133	1800	900	1800	900	1800	900	1800	900	410
063	2s	056	1121	714	1400	1200	100	450	540	266	1500	600	1500	600	1500	600	1500	600	450
	3	063	750	800					453	144	1900	1000	1900	1000	1900	1000	1900	1000	460
068	2s	056	939	714	1400	1200	100	300	540	266	1500	600	1500	600	1500	600	1500	600	411
	3	063	602	800					1600	200	453	144	1900	1000	1900	1000	1900	1000	1900
072	2s	056	1271	714	1400	1000	50	600	540	266	1500	600	1500	600	1500	600	1500	600	405
	3	063	900	800					453	144	1900	1000	1900	1000	1900	1000	1900	1000	465
079	2s	056	1121	714	1400	1400	50	450	569	296	1500	600	1500	600	1500	600	1500	600	424
	3	063	1050	800					606	296	1500	600	1500	600	1500	600	1500	600	463
090	2s	063	1200	800	1400	1400	50	100	606	296	1500	600	1500	600	1500	600	1500	600	463
	3	071	1173	900					642	283	1600	700	1600	700	1600	700	1600	700	524

*) gg=01,02,04,21

**) gg=05,06,08,25

Dimensions and weights (mm and kg)

EQLR Centrifugal fan, belt driven

Size		Fan size	Outlet up/down						Weight	R	T
			gg=02			gg=06					
aaa	b		L	M	N*	L	M	N* *			
008	3	022	950	250	512	1000	300	660	85	700	300
009	2	022	950	250	512	1000	300	660	85	700	300
	3	025	1000	300	516	1000	300	625	95		400
011	2	025	1000	300	516	1000	300	625	95	700	400
014	2-	028	1100	400	544	1150	450	750	115	700	400
	3-	031	1100	400	544	1150	450	686	120		500
018	2-	031	1150	450	531	1150	450	686	150	700	500
020	2-	031	1150	450	531	1150	450	686	135	700	500
	3	035	1300	600	607	1350	650	841	160		
023	2s	035	1100	400	407	1100	400	571	190	700	500
	3	040	1400	500	629	1400	500	836	200	900	600
027	2	035	1300	400	607	1350	650	841	186	900	500
	3	040	1400	500	629	1450	750	886	200		600
032	2s	040	1150	450	504	1150	450	566	195	700	500
	3	045	1500	600	634	1500	600	870	225	900	600
036	2	040	1400	500	629	1450	750	886	221	900	600
	3	045	1500	600	634	1550	850	920	250		
041	2s	045	1300	400	434	1300	400	650	280	900	600
	3	050	1600	700	642	1600	700	910	300		800
045	2s	045	1300	400	434	1300	400	650	280	900	600
	3	050	1600	700	642	1600	700	910	275		800
047	2s	045	1300	400	434	1300	400	650	280	900	600
	3	050	1600	700	642	1600	700	910	335		800
050	2s	050	1300	400	346	1300	400	595	335	900	800
	3	056	1800	900	736	1800	900	1021	425		
054	2s	050	1300	400	346	1300	400	595	417	900	800
	3s	056	1500	600	406	1500	600	711	380		
056	2	050	1600	700	642	1600	700	905	313	900	800
	3	056	1800	900	736	1800	900	1021	410		
063	2s	056	1500	600	406	1500	600	711	450	900	800
	3	063	1900	1000	708	1900	1000	1045	460		1000
068	2s	056	1500	600	406	1500	600	711	411	900	800
	3	063	1900	1000	708	1900	1000	1045	460		1000
072	2s	056	1500	600	406	1500	600	711	405	900	800
	3	063	1900	1000	708	1900	1000	1045	465		1000
079	2s	056	1500	600	406	1500	600	711	425	900	800
	3	063	1600	700	384	1600	700	733	475		1000
090	2s	063	1600	700	384	600	700	733	475	900	1000
	3	071	1800	900	460	1800	900	820	550		1000

*) gg=01,02,04,21

**) gg=05,06,08,25

Dimensions and weights (mm and kg)

EQPA Panel filter

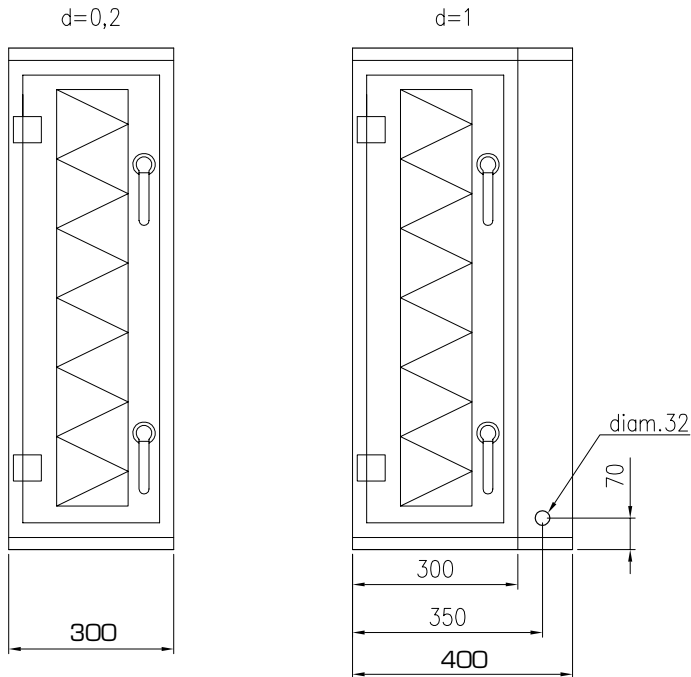

Size	Weight (kg)	
	d=0, 2	d=1
005	15	18
008	18	22
009	20	22
011	22	25
014	25	30
018	30	35
020	35	40
023	35	40
027	35	40
032	45	50
036	45	50
041	45	50
045	50	50
050	55	60
054	55	60
056	60	60
063	65	75
068	70	80
072	65	75
079	75	85
090	85	95

Dimensions and weights (mm and kg)

EQPB Filter

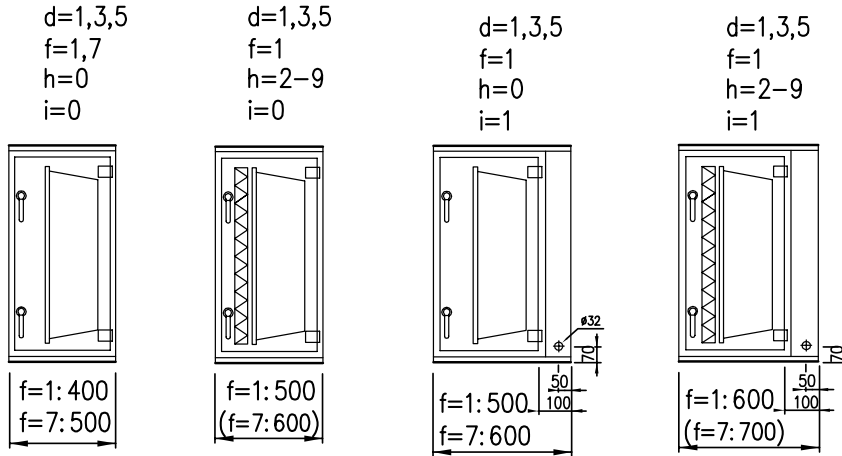

d=1,3,5 f=1,7				
	h=0, i=0	h=2-9, i=0	h=0, i=1	h=2-9, i=1
Size	Weight, kg	Weight, kg	Weight, kg	Weight, kg
005	10	10,5	13	14
008	10	11	14	16
009	11	11,5	14	15
011	12	13	16,5	18,5
014	13	14	17	19
018	19	20,5	24,5	26,5
020	19	20	23	25
023	19	20,5	25,5	28
027	25	27,5	30,5	33,5
032	26	29	33	38
036	27	29,5	32,5	35,5
041	29	32,5	36,5	41,5
045	33	26	39,5	33,5
050	33	37,5	42	48
054	40	43,5	47,5	52,5
056	40	43,5	46,5	50,5
063	41	45,5	50	56
068	51	55	58,5	64
072	42	47	52	59
079	52	56,5	61	67
090	59	65	69	77

Dimensions and weights (mm and kg)

EQPB Filter

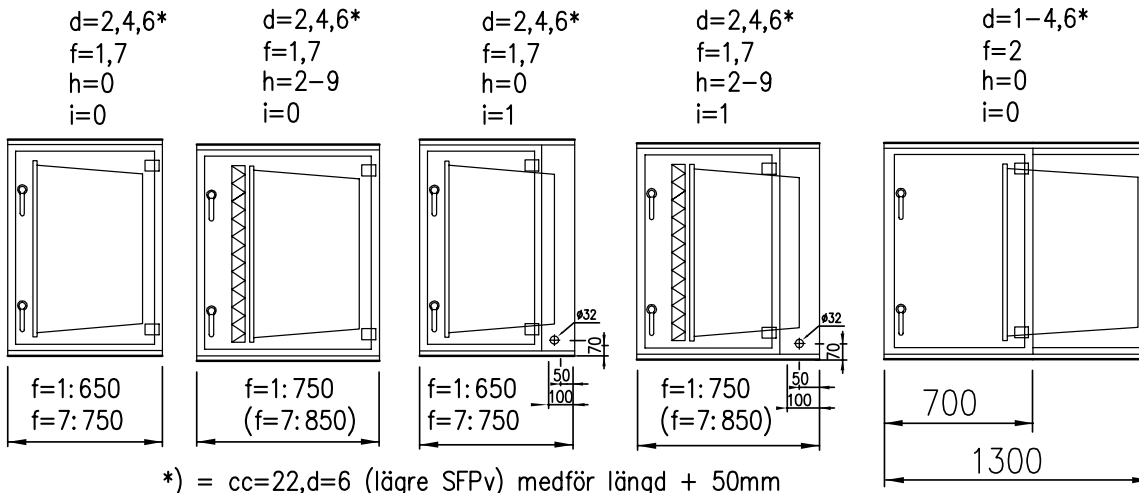

Size	d=2,4,6 f=1, 7*				d=1-4.6 f=2
	h=0, i=0	h=2-9, i=0	h=0, i=1	h=2-9, i=1	h=0, i=0
Weight, kg	Weight, kg	Weight, kg	Weight, kg	Weight, kg	Weight, kg
005	10	10,5	13,5	15	10
008	10	11	15	17	10
009	11	11,5	14,5	16	11
011	12	13	17,5	19,5	12
014	13	14	18	20	13
018	19	20,5	25	28,5	19
020	19	20	24	26	19
023	19	20,5	26,5	30	19
027	25	27,5	31	35,5	25
032	26	29	34	30	26
036	27	29,5	33	37,5	27
041	29	32,5	38	44	29
045	33	26	40,5	35,5	33
050	33	37,5	43,5	50,5	33
054	40	43,5	49	55	40
056	40	43,5	47,5	53	40
063	41	45,5	50,5	58,5	41
068	51	55	60	66,5	51
072	42	47	54	62	42
079	52	56,5	62,5	69,5	52
090	59	65	71	80	59

*) Function extended 100 mm

Dimensions and weights (mm and kg)

EQPB Filter

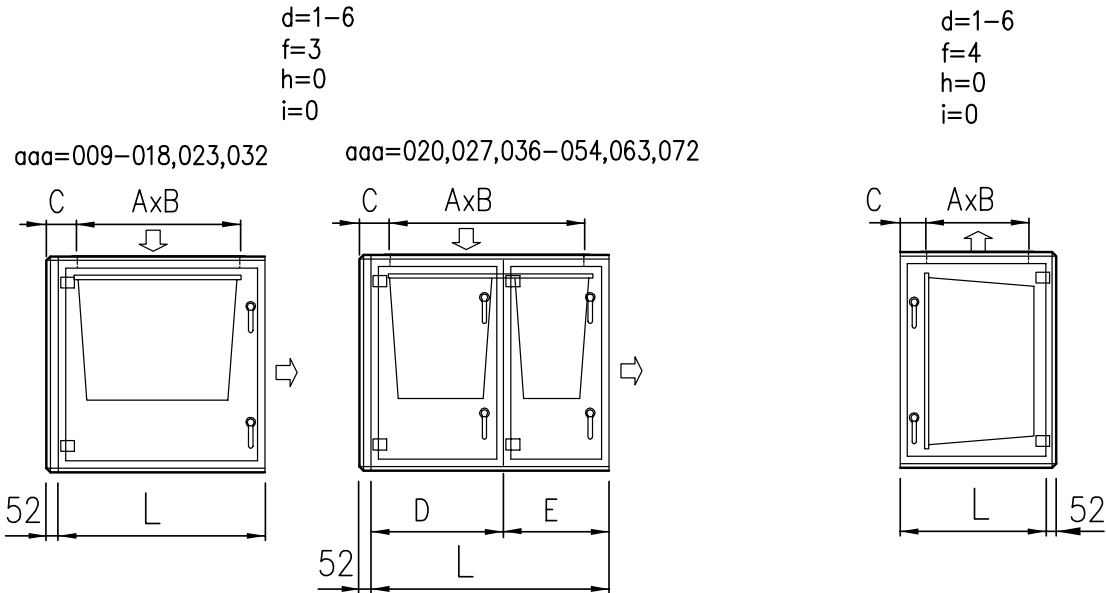

Size	d=1-6 f=3							d=1-6 f=4				
	A	B	L	C	D	E	Weight, kg	A	B	C	L	Weight, kg
005*	-	-	-	-	-	-	-	Ø350	-	300**	700	10
005	-	-	-	-	-	-	-	Ø300	700	200	700	10
008*	Ø400	-	550	300**	550	-	10	Ø400	-	325**	700	11
008	300	880	-	200	550	-	10	Ø400	-	325**	700	10
009*	Ø500	-	750	350*	750	-	11	Ø500	-	375**	700	11
009	500	500	750	200	750	-	11	Ø500	-	375**	700	11
011	400	800	650	200	650	-	12	400	800	125	700	12
014	500	800	750	200	750	-	13	500	800	125	700	13
018	500	1100	750	200	750	-	19	500	1100	125	700	19
020	800	800	1150	300	750	400	19	600	800	125	900	19
023	600	1400	750	150	750	-	19	600	1400	125	900	19
027	800	1100	1150	300	750	400	25	600	1200	125	900	25
032	800	1400	950	150	950	-	26	600	1400	125	900	26
036	1000	1100	1450	300	750	700	27	600	1200	125	900	27
041	800	1700	1150	300	750	400	29	600	1700	125	900	29
045	1000	1400	1450	300	750	400	33	600	1400	125	900	33
050	800	2000	1250	300	650	600	33	600	2000	125	900	33
054	1000	1700	1450	300	750	700	40	600	1700	125	900	40
056	-	-	-	-	-	-	-	600	1400	125	900	40
063	1000	2000	1450	300	750	700	41	600	2000	125	900	41
068	-	-	-	-	-	-	-	600	1700	125	900	51
072	1000	2200	1450	300	750	700	42	600	2200	125	900	42
079	-	-	-	-	-	-	-	600	2000	125	900	52
090	-	-	-	-	-	-	-	600	2200	125	900	59

*) Round connection
 **) To the centre of the hole



Dimensions and weights (mm and kg)

EQPF HEPA filter

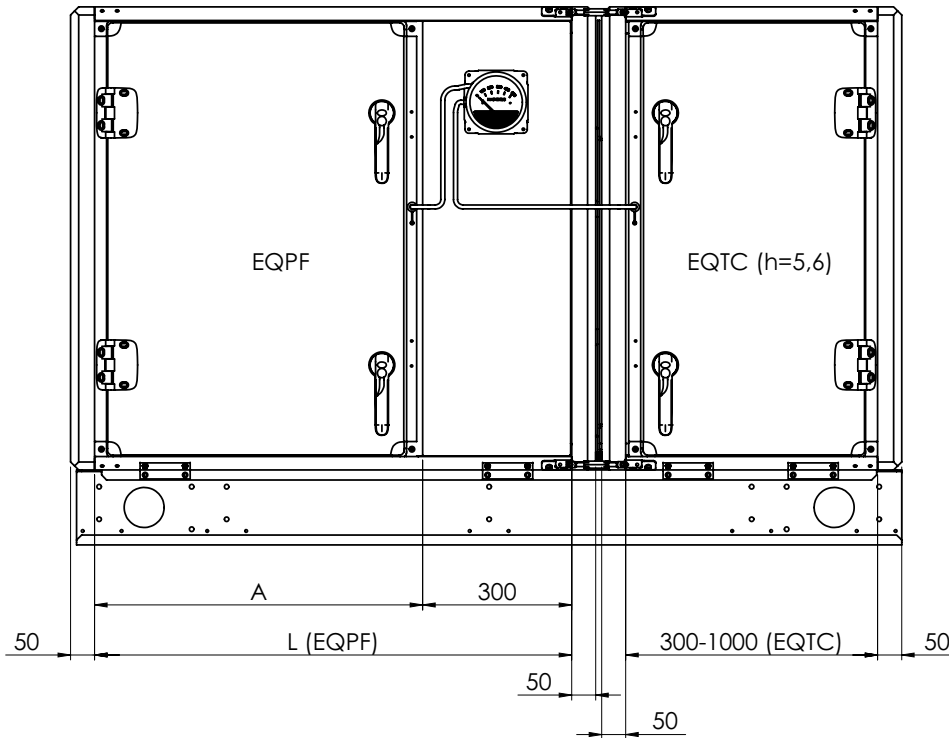

Unit size	Weight, kg
005	14.5
009	21.3
014	32.4
018	35.9
020	43.2
027	47.9
036	54.4
041	67.1
045	75.2
047	77.0
054	79.8
056	94.7
063	97.0
068	100.8
072	102.3
079	128.3
090	128.6

EQPF should always be ordered together with EQTC (h=5,6) on a common base frame EQAZ-D4.
Both EQPF and EQTC must have casing EQGB.

Code bb	A	L
09	600	900
10	700	1000
11	800	1100
12	900	1200



Dimensions and weights (mm and kg)

EQPK Carbon filter

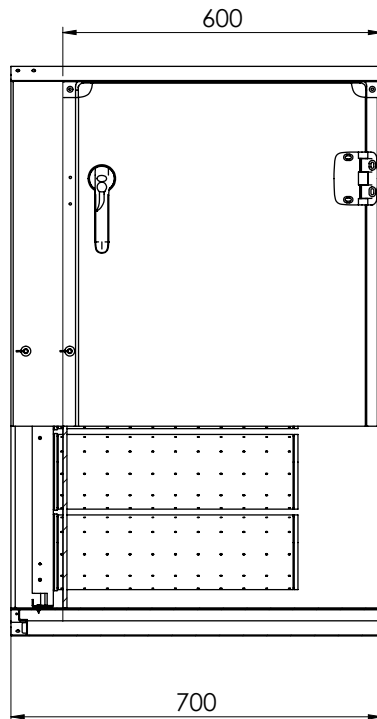

Unit size	Weight, kg
005	26
008	56
009	51
011	66
014	75
018	100
020	112
023	155
027	149
032	159
036	199
041	223
045	248
047	260
050	303
054	297
056	309
063	346
068	371
072	395
079	432
090	493

Dimensions and weights (mm and kg)

EQRA Rotary heat exchanger REGOTERM®

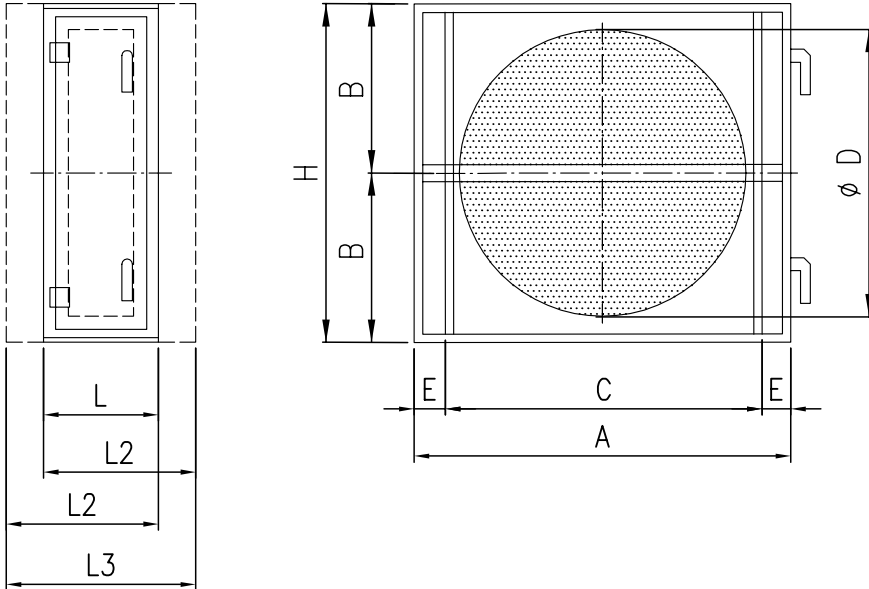

Size	A	B	C	D	E	H	L	L2	L3	Weight, kg
005	-	476	800	630	-	952	300	350	400	44
008	-	576	1100	930	-	1152	300	350	400	77
009*	1400	776	800	1200	300	1552	300	-	-	162
011	-	676	1200	1030	-	1352	300	400	500	95
014*	1400	776	1100	1200	150	1552	300	-	-	150
018	-	776	1400	1230	-	1552	300	450	600	128
020*	1800	1076	1100	1600	350	2152	300	-	-	274
023	-	926	1700	1530	-	1852	300	450	600	190
027*	1800	1076	1400	1600	200	2152	300	-	-	256
032	-	1026	1800	1630	-	2052	300	550	800	217
036*	2400	1376	1400	2200	500	2752	350	-	-	480
041	-	1076	2000	1830	-	2152	350	-	-	262
045*	2400	1376	1700	2200	350	2752	350	-	-	456
047	-	1076	2300	1800	-	2152	350	-	-	277
050	-	1226	2300	2130	-	2452	350	-	-	344
054*	2600	1376	2000	2400	300	2752	350	-	-	503
063*	2600	1376	2300	2400	150	2752	350	-	-	479
072	-	1376	2600	2400	-	2752	350	-	-	434

* eQ PLUS

Dimensions and weights (mm and kg)

EQRC Plate heat exchanger RECUTERM®

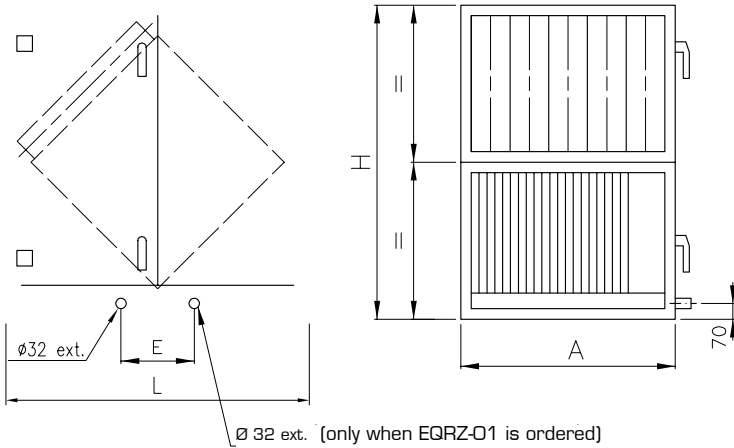

Principle for inspection doors

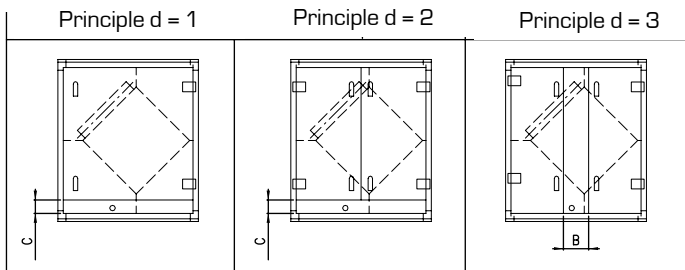

Size	A	B		C		E		H	L		Weight, kg		Insp.principle D	
		Standard	Small	Standard	Small	Standard	Small		Standard	Small	Standard	Small		
005	800	-	-	180	-	275	-	952	750	-	35	-	1	-
008	1000	-	-	130	130	415	275	1152	1000	750	65	35	2	1
009	800	-	-	180	180	560	415	1552	1400	1000	70	45	2	2
011	1200	-	-	130	130	415	-	1352	1000	900	80	55	2	2
014	1100	-	-	180	180	560	415	1552	1400	1000	90	60	2	2
018	1400	-	-	180	180	560	415	1552	1400	1000	115	80	2	2
020	1100	800	-	-	100	-	560	2152	190	100	190	100	3	2
023	1700	-	-	180	180	560	560	1852	130	120	130	120	2	2
027	1400	800	-	-	100	-	560	2152	240	100	240	100	3	2
032	1800	800	-	-	200	-	560	2052	280	130	280	130	3	2
036	1400	800	650	-	-	-	-	2752	260	220	260	220	3	3
041	2000	800	-	-	100	-	560	2152	320	160	320	160	3	2
045	1700	1000	650	-	-	-	-	2752	320	270	320	270	3	3
047	2300	800	-	-	100	-	-	2152	370	180	370	180	3	2
050	2300	700	700	-	-	-	-	2452	370	235	370	235	3	3
054	2000	1000	650	-	-	-	-	2752	385	330	385	330	3	3
063	2300	1000	650	-	-	-	-	2752	440	370	440	370	3	3
072	2600	1000	650	-	-	-	-	2752	500	410	500	410	3	3



Dimensions and weights (mm and kg)

EQQA Humidifier

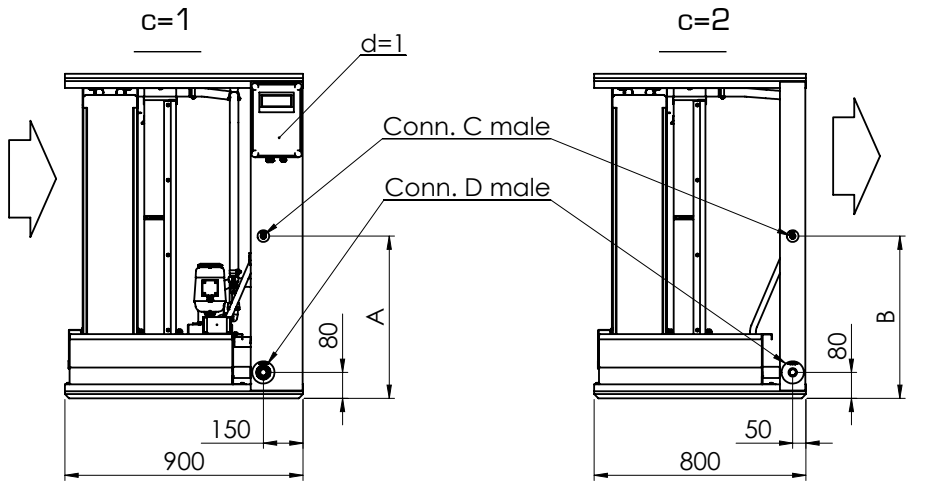

Size	Water supply			Water draining	c=1 Weight	c=2 Weight	Area humid.fill
	A	B	C	D	Kg	Kg	M ²
009	300	450	15 (1/2")	∅ 32	60	48	0.230
011	300	450	15 (1/2")	∅ 32	74	62	0.315
014	300	450	15 (1/2")	∅ 32	85	74	0.339
018	300	450	15 (1/2")	∅ 32	74	62	0.459
020	550	550	15 (1/2")	∅ 32	87	75	0.594
023	550	550	15 (1/2")	∅ 32	101	89	0.750
027	550	550	15 (1/2")	∅ 32	118	106	0.804
032	550	550	15 (1/2")	∅ 32	110	98	0.960
036	550	550	15 (1/2")	∅ 32	138	126	1.091
041	550	550	15 (1/2")	∅ 32	157	145	1.170
045	550	550	15 (1/2")	∅ 32	119	107	1.351
047	550	550	15 (1/2")	∅ 32	125	114	1.365
050	550	550	20 (3/4")	2 x ∅ 32	154	142	1.575
054	550	550	15 (1/2")	∅ 32	175	163	1.636
056	550	550	15 (1/2")	∅ 32	163	141	1.778
063	550	550	20 (3/4")	2 x ∅ 32	170	157	1.890
068	550	550	15 (1/2")	∅ 32	187	175	2.153
072	550	550	20 (3/4")	2 x ∅ 32	206	194	2.160
079	550	550	20 (3/4")	2 x ∅ 32	197	184	2.511
090	550	550	20 (3/4")	2 x ∅ 32	225	212	2.870

Dimensions and weights (mm and kg)

EQKA COOLER

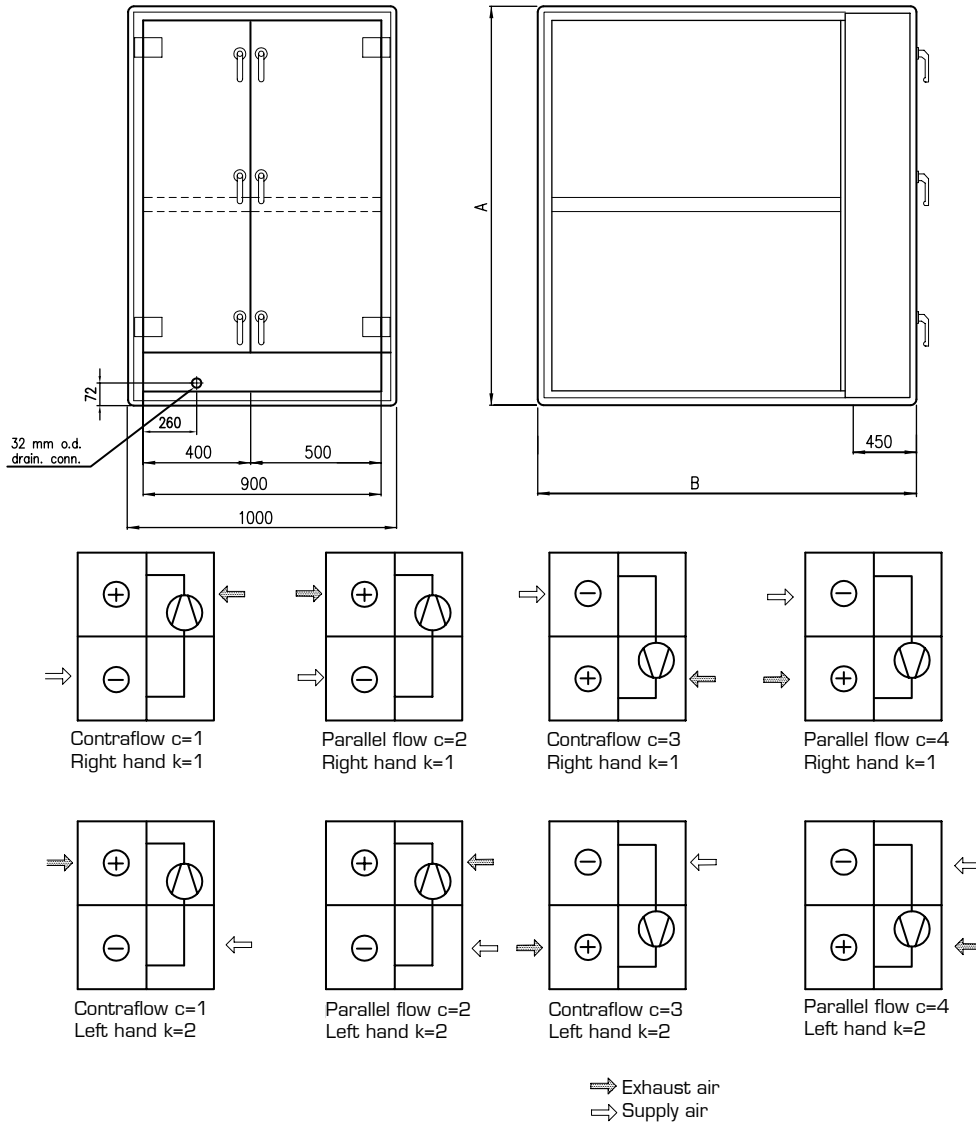

Size	A	B	Weight, kg	
			Output variant 1	Output variant 2
008	1152	1550	178	193
011	1352	1650	206	232
018	1552	1850	248	326
023	1852	2150	336	443
032	2052	2250	380	476
041	2152	2450	484	623
050	2452	2750	631	701
072	2752	3050	841	1024



Dimensions and weights (mm and kg)

EQKB ReCooler

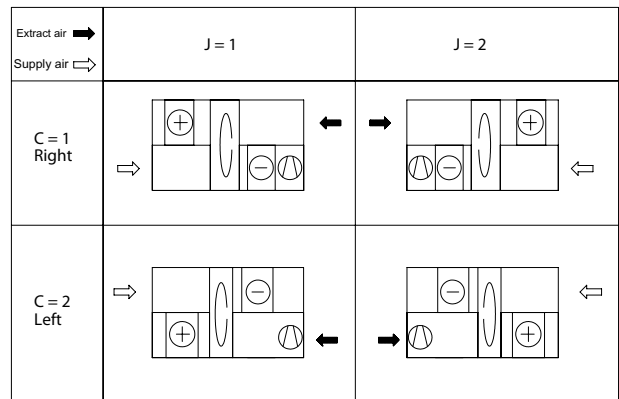
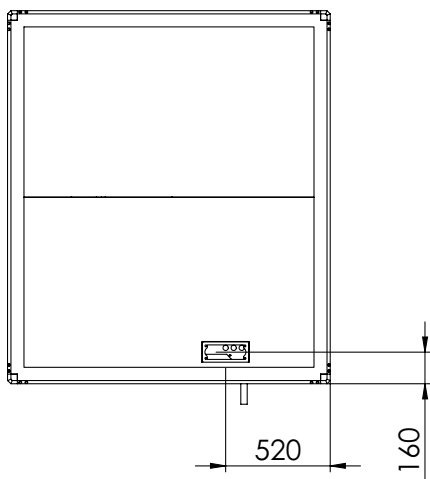
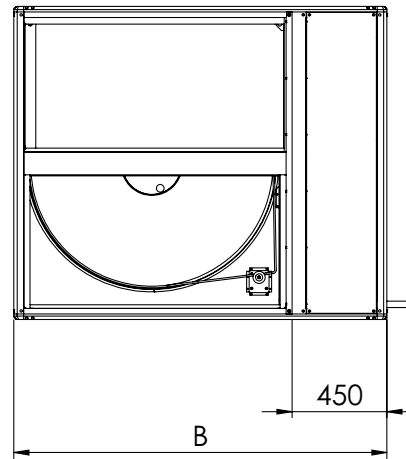
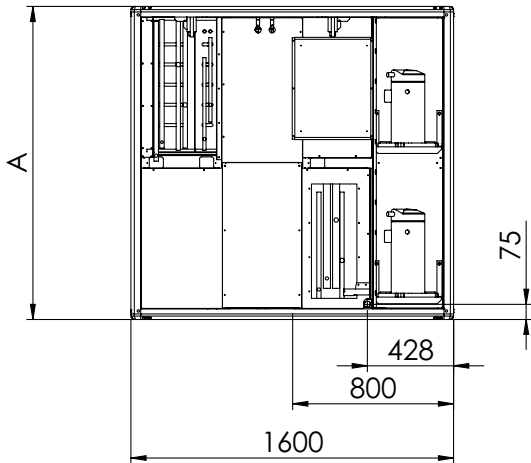

Size	A	B	Weight kg (excl. casing)
008	1152	1550	300
011	1352	1650	400
018	1552	1850	500
023	1852	2150	600
032	2052	2250	700
041	2152	2450	800
050	2452	2750	1000
072	2752	3050	1300



Dimensions and weights (mm and kg)

EQKC Combi Cooler

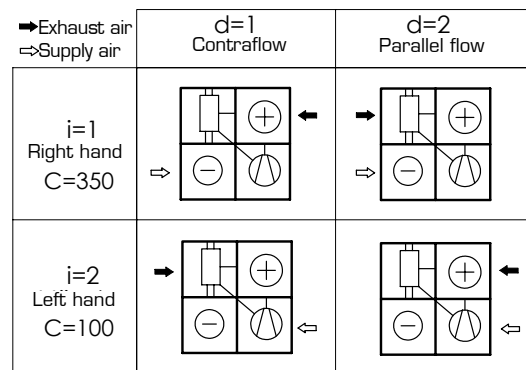
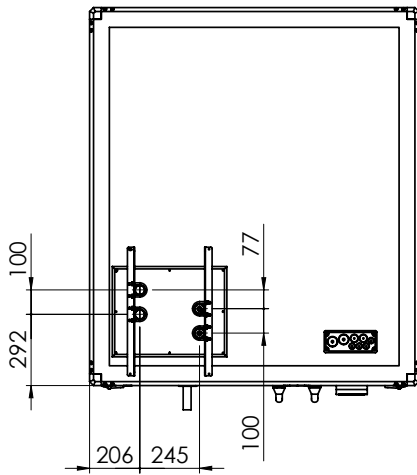
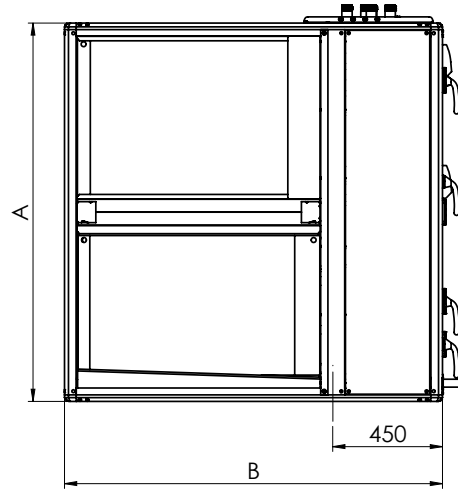
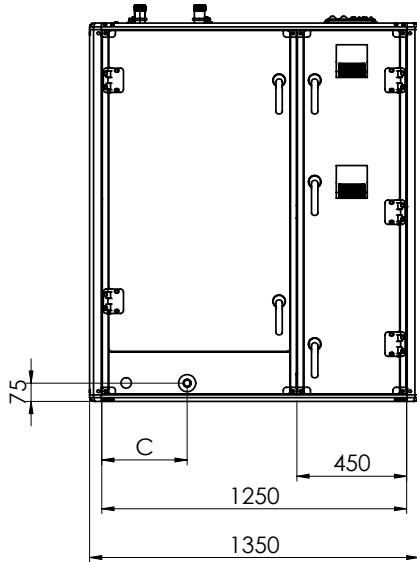

Storlek	A	B	Weight kg (excl. casing)
014	1552	1550	330 - 385
018	1552	1850	385 - 440
023	1852	2150	475 - 555
032	2052	2250	555 - 730
041	2152	2450	690 - 815

Dimensions and weights (mm and kg)

EQRF ECOTERM®

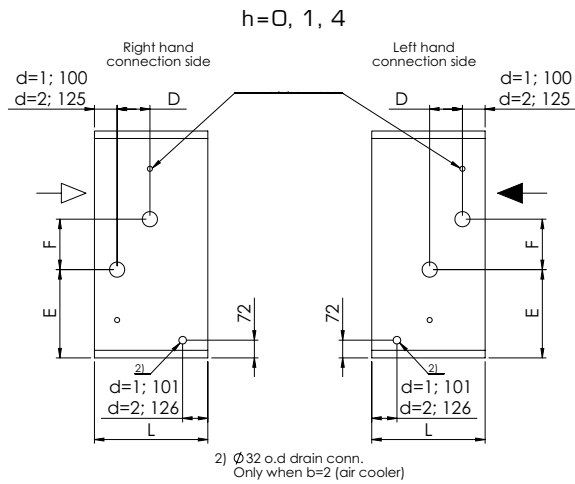

Normal face area c=1

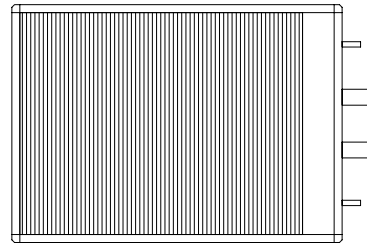

Max face area c=2

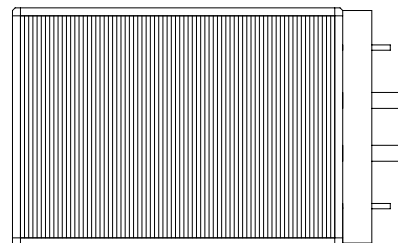

Size 005-018 : 100

Size 020-090 : 150

h=2 withdrawable droplet eliminator

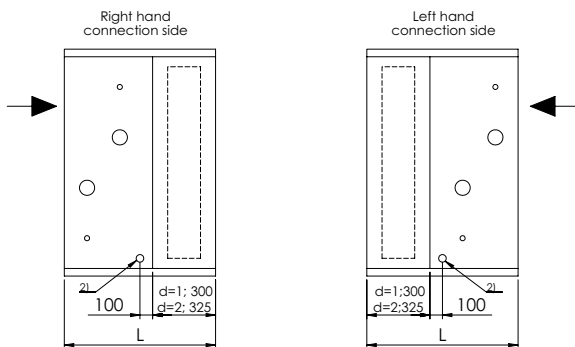

Output variant c (rr)	L							
	b=1 (heater)	c=1 (normal size)			c=2 (full size)			
		b=2 (cooler)			b=1 (värmare)	b=2 (cooler)		
		h=0	h=1,4	h=2		h=0	h=1,4	h=2
1 (4)	500	500	500	600	550	550	550	650
2 (6)	500	500	600	650	550	550	650	700
3 (8)	500	600	600	750	550	650	650	800
4 (10)	500	600	700	800	550	650	750	850

Dimensions on next page.

Dimensions and weights (mm and kg)

EQRFCOTERM®

Unit size	E	F	Output var.	Connection dimensions at different number of WV and dimension D between connetions									
				25		32		50		80			
				WV	D	WV	D	WV	D	WV	D		
005	191	120	1	6-18	87								
			2	8-28	144								
			3	10-38	205	6-8	205						
			4	14-48	263	8-12	263						
008	201	200	1	8-24	87								
			2	10-38	144	6-8	144						
			3	14-50	205	8-12	205						
			4	18-64	263	10-16	263	6-8	263				
011	251	200	1	8-30	87								
			2	12-46	144	8-10	144						
			3	16-62	205	10-14	205	6-8	205				
			4	20-78	263	12-18	263	6-10	263				
009, 014, 018	301	200	1	10-36	87	6-8	87						
			2	16-56	144	10-14	144	6-8	144				
			3	20-74	205	12-18	205	6-10	205				
			4	24-94	263	14-22	263	8-12	263				
023	368	200	1	12-46	87	8-10	87						
			2	18-68	144	10-16	144	6-8	144				
			3	24-92	205	14-22	205	8-12	205				
			4	30->	263	18-28	263	10-16	263	4-8	263		
032	418	200	1	14-52	87	8-12	87						
			2	20-78	144	12-18	144	6-10	144				
			3	28->	205	16-26	205	8-14	205				
			4	34->	263	20-32	263	10-18	263	6-8	263		
020, 027, 041, 047	451	200	1	14-54	87	8-12	87						
			2	22-82	144	12-20	144						
			3	28->	205	16-26	205	8-14	205				
			4	36->	263	20-34	263	10-18	263	6-8	263		
050	518	200	1	18-64	87	10-16	87	6-8	87				
			2	26->	144	14-24	144	8-12	144				
			3	34->	205	20-32	205	10-18	205	4-8	205		
			4	42->	263	24-40	263	12-22	263	6-10	263		
036, 045, 054, 063, 072	584	200	1	20-72	87	12-18	87	6-10	87				
			2	28->	144	16-26	144	8-14	144				
			3	38->	205	22-36	205	12-20	205	6-10	205		
			4	46->	263	26-44	263	14-24	263	6-12	263		
056, 068, 079, 090	751	200	1	24-90	87	14-22	87	8-12	87				
			2	36->	144	20-34	144	10-18	144	6-8	144		
			3	46->	205	28-44	205	14-26	205	6-12	205		
			4	58->	263	34-56	263	18-32	263	8-16	263		

Output variants 1, 2, 3 and 4		
Size	E	F
006	192	120
008	202	
009	302	200
011	252	
014	302	200
018	302	200
020	452	200
023	377	
027	452	200
032	427	
036	585	200
041	452	200
045	585	200
050	527	
054	585	200
063	585	

The connections have male pipe threads.

For detailed information about flanges, see Accessories.

Connections tolerance is ± 4 mm.

Dimensions and weights (mm and kg)

EQRT ECONET®

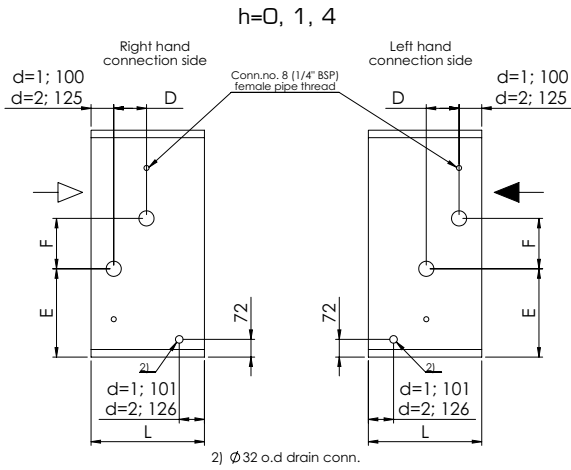

Normal face area d=1

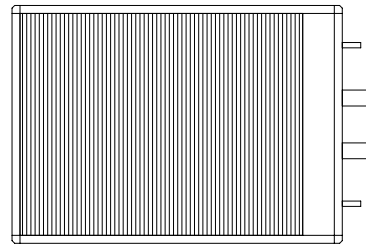

Max face area d=2

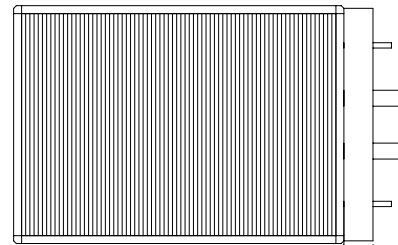

Size 005-018 : 100
Size 020-090 : 150

h=2 withdrawable droplet eliminator

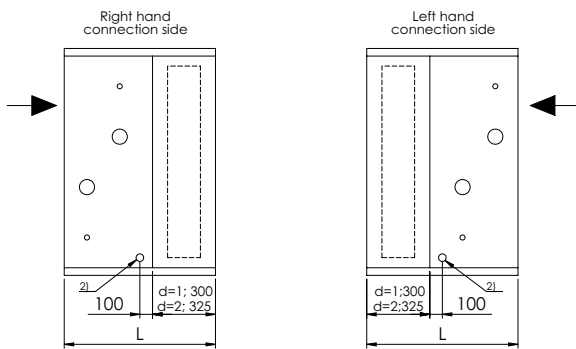

2) Ø 32 mm o.d drain plain stainless steel.

Output variant c (rr)	L					
	d=1 (normal size)			d=2 (full size)		
	h=0	h=1,4	h=2	h=0	h=1,4	h=2
1 (4)	400	500	650	450	550	700
2 (6)	400	500	650	450	550	700
3 (8)	500	600	750	550	650	800
4 (10)	500	600	800	550	650	850
5 (12)	600	700	850	650	750	900

Dimensions on next page.

Dimensions and weights (mm and kg)

EQRT ECONET®

Unit size	E	F	Output var.	Connection dimensions at different number of VV and dimension D between connetions					
				25		32		50	
				W	D	W	D	W	D
008	201	200	1	8-24	87				
			2	10-38	144				
			3	14-50	205				
			4	18-64	263				
			5	20-76	321				
011	251	200	1	8-30	87				
			2	12-46	144				
			3	16-62	205				
			4	20-78	263				
			5	24-94	321				
009, 014, 018	301	200	1	10-36	87				
			2	16-56	144				
			3	20-74	205				
			4	24-94	263				
			5	30->	321				
023	301	200	1	12-46	87				
			2	18-68	144				
			3	24-92	205				
			4	30->	263				
			5	36->	321				
032	368	200	1			8-12	87		
			2			12-18	144		
			3			16-26	205		
			4			20-32	263		
			5			24-38	321		
020, 027	418	200	1	14-54	87				
			2	22-82	144				
			3	28->	205				
			4	36->	263				
			5	42->	321				
041, 047	451	200	1			8-12	87		
			2			12-20	144		
			3			16-26	205		
			4			20-34	263		
			5			24-40	321		
050	518	200	1					6-8	87
			2					8-12	144
			3					10-18	205
			4					12-22	263
			5					14-26	321
036, 045	584	200	1			12-18	87		
			2			16-26	144		
			3			22-36	205		
			4			26-44	263		
			5			32-54	321		
054, 063 072	584	200	1					6-10	87
			2					8-14	144
			3					12-20	205
			4					14-24	263
			5					16-30	321

The connections have male pipe threads.
For detailed information about flanges, see Accessories.
Connections tolerance is ± 4 mm.

Output variants 1,2,3,4,5	
Size	E
008	202
009	302
011	252
014	302
018	302
020	452
023	377
027	452
032	427
036	585
041	452
045	585
050	527
054	585
063	602
072	602

Dimensions and weights (mm and kg)

EQSA Silencer

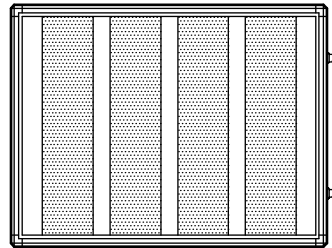
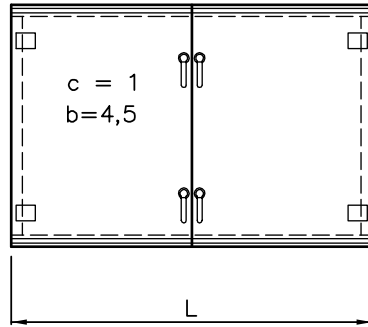
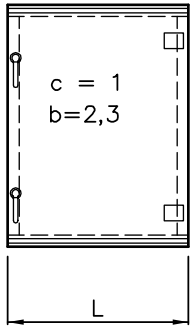
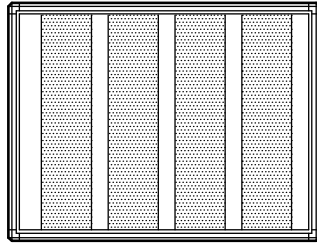
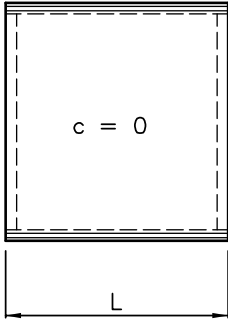

Size	Weight (kg)			
	L=500 (b=2)	L=900 (b=3)	L=1300 (b=4)	L=1700 (b=5)
005	10	14	20	26
008	18	24	33	45
009	14	22	28	36
011	14	30	39	51
014	21	33	42	54
018	28	44	56	72
020	30	42	54	69
023	40	65	85	110
027	40	56	72	92
032	45	65	85	110
036	48	68	88	112
041	60	84	108	138
045	60	85	110	140
050	77	105	140	182
054	72	102	132	168
056	70	100	135	165
056	70	100	135	165
063	84	119	154	196
068	84	120	162	198
072	96	136	176	224
079	98	140	189	231
090	112	160	162	198

Dimensions and weights (mm and kg)

EQSD Sound attenuator, mounted in duct work

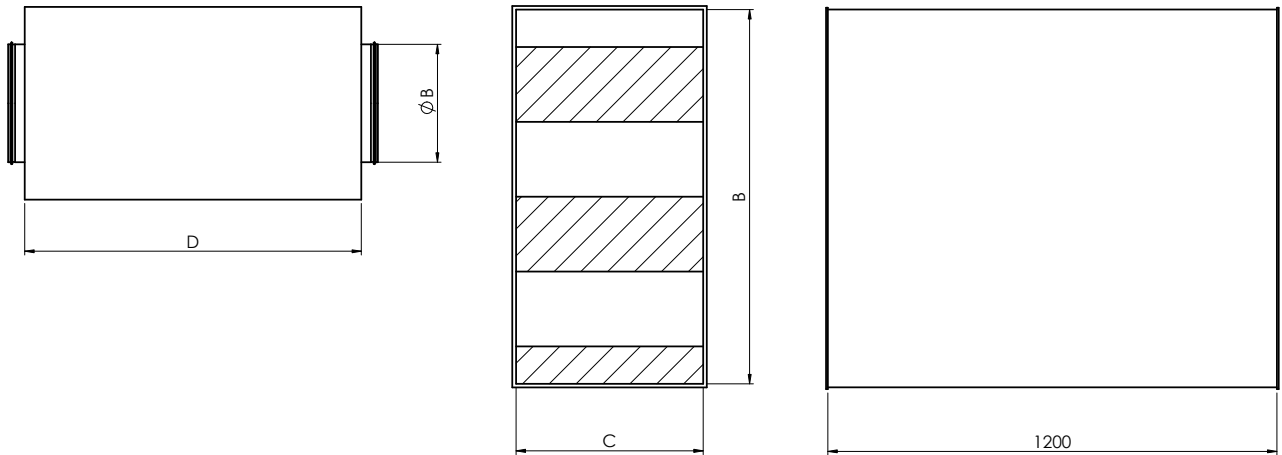

B	C	D	Weight, kg
Ø 031	-	900	28
Ø 040	-	1200	42
Ø 050	-	1200	71
080	040	1200	36
110	050	1200	53
140	060	1200	75
140	080	1200	83
170	080	1200	100
200	080	1200	120
200	100	1200	130
240	100	1200	155

Dimensions and weights (mm and kg)

EQTB Empty section

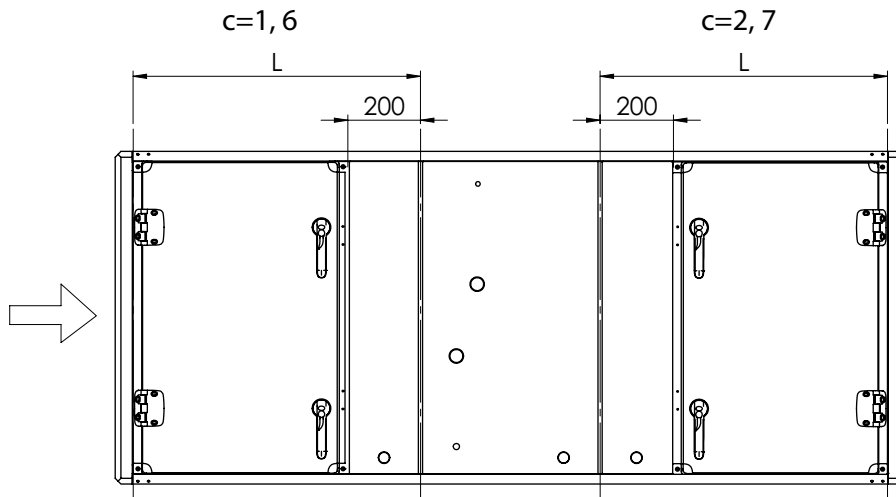

B	L
6	600
7	700
8	800
9	900

Dimensions and weights (mm and kg)

EQTC Empty section
g=0, without drain tray

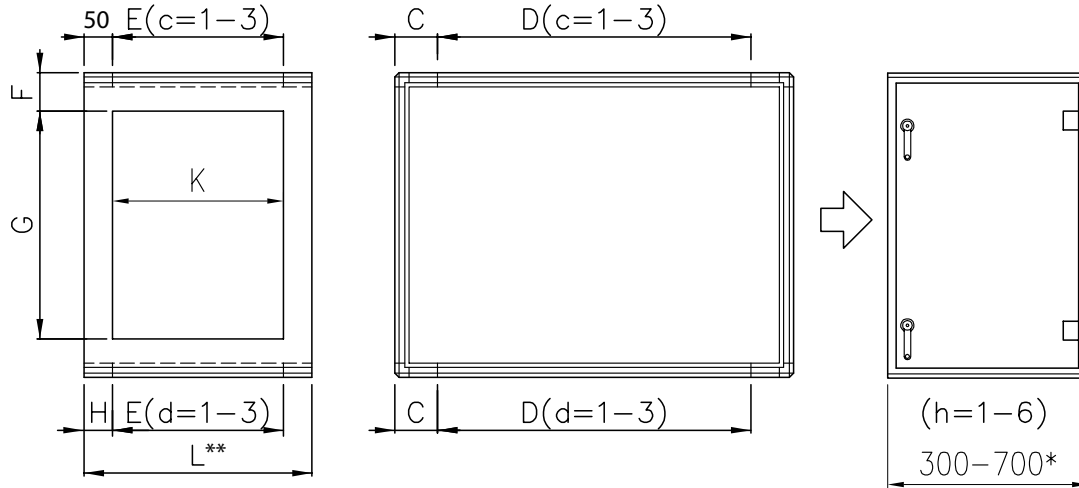

*) When L is bigger than 700, a door (700) is positioned first in the air flow, then there is fixed panel

**) When hole on side or with internal damper (EQA-Z-12) an EQTC L=100 is needed before this empty section

EQTC Empty section
g=2, with drain tray

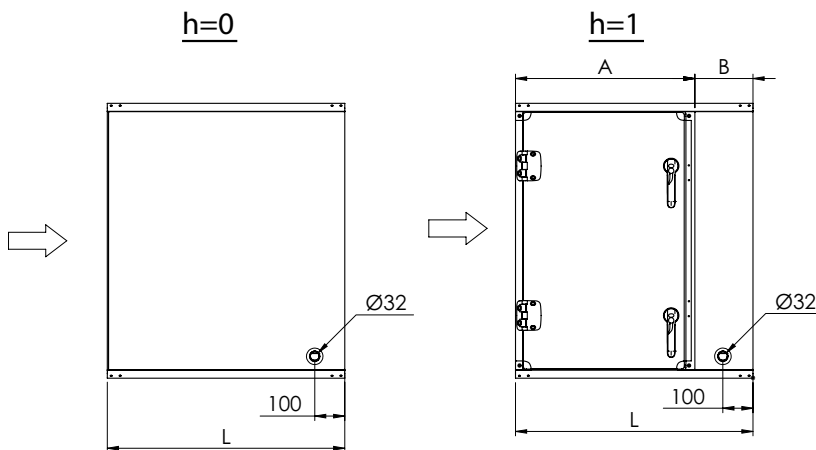

h=0	h=1		
L	L	A	B
300	-	-	-
350	-	-	-
400	-	-	-
450	-	-	-
500	-	-	-
550	-	-	-
600	600	400	200
650	650	450	200
700	700	500	200
750	750	550	200
800	800	600	200
850	850	650	200
900	900	700	200
950	950	700	250
1000	1000	700	300
1050	1050	700	350
1100	1100	700	400
1150	1150	700	450
1200	1200	700	500
1250	1250	700	550
1300	1300	700	600

Dimensions and weights (mm and kg)

EQTC Empty section with holes other than for mixing section, g=0
c, d, e, f = 1 – 3

L	E	K
50	-	-
100	-	-
150	-	-
200	-	-
250	-	-
300	-	-
350	-	-
400	300	-
450	300	-
500	400	-
550	400	400
600	500	500
650	500	500
700	600	600
750	600	600
800	700	700
850	700	700
900	800	800
950	800	800
1000	900	900
1050	900	900
1100	1000	1000
1150	1000	1000
1200	1100	1100

L	E	K
1350	-	-
1400	-	-
1450	-	-
1500	-	-
1550	-	-
1600	-	-
1650	-	-
1700	-	-
1750	-	-
1800	-	-
1850	-	-
1900	-	-
1950	-	-
2000	-	-
2050	-	-
2100	-	-
2150	-	-
2200	-	-
2250	-	-
2300	-	-
2350	-	-
2400	-	-
2450	-	-
2500	-	-
2550	-	-

Dimensions and weights (mm and kg)

EQTC Empty section, when used as mixing section, g=0

	When used as mixing section Connect. end wall (internal damper)	When used as mixing section Connection ceiling/base			
Size	L	L	C	D	E
005	200	350	400	Ø315	-
008	200	500	550	Ø400	-
009	200	550	450	Ø500	-
011	200	400	200	800	300
014	200	400	185	800	300
018	200	400	185	1100	300
020	300	500	185	800	400
023	300	500	185	1400	400
027	300	600	185	1100	500
032	300	600	200	1400	500
036	300	700	185	1100	600
041	300	500	185	1700	400
045	300	700	185	1400	600
050	300	600	185	2000	500
054	300	700	185	1700	600
056	300	900	200	1400	800
063	300	700	185	2000	600
068	300	900	185	1700	800
072	300	700	200	2000	600
079	300	900	185	2000	800
090	300	900	200	2000	800

Dimensions and weights (mm and kg)

EQTC Empty section, g=0

For connection of entire unit

c, d, e, f = 4

Size	Connection in ceiling c, d = 4	Connection in side e, f = 4							
	L	L	C	D	E	F	G	H	K
005	500	900	100	600	400	78	320	150	700
008	600	1200	100	900	500	78	420	150	1000
009	800	900	100	600	700	78	620	150	700
011	700	1300	100	1000	600	78	520	150	1100
014	800	1200	100	900	700	78	620	150	1000
018	800	1500	100	1200	700	78	620	150	1300
020	1100	1200	100	900	1000	78	920	150	1000
023	1000	1800	100	1500	900	78	770	150	1600
027	1100	1500	100	1200	1000	78	920	150	1300
032	1100	1900	100	1600	1000	78	870	150	1700
036	1400	1500	100	1200	1300	78	1220	150	1300
041	1100	2100	100	1800	1000	78	920	150	1900
045	1400	1800	100	1500	1300	78	1220	150	1600
050	1300	2400	100	2100	1200	78	1070	150	2200
054	1400	2100	100	1800	1300	78	1220	150	1900
056	1700	1800	100	1500	1600	78	1520	150	1600
063	1400	2400	100	2100	1300	78	1220	150	2200
068	1700	2100	100	1800	1600	78	1520	150	1900
072	1400	2700	100	2400	1300	78	1220	150	2500
079	1700	2400	100	2100	1600	78	1520	150	2200
090	1700	2700	100	2400	1600	78	1520	150	2500

Dimensions and weights (mm and kg)

EQKE Air heater for hot water, mounted in duct work

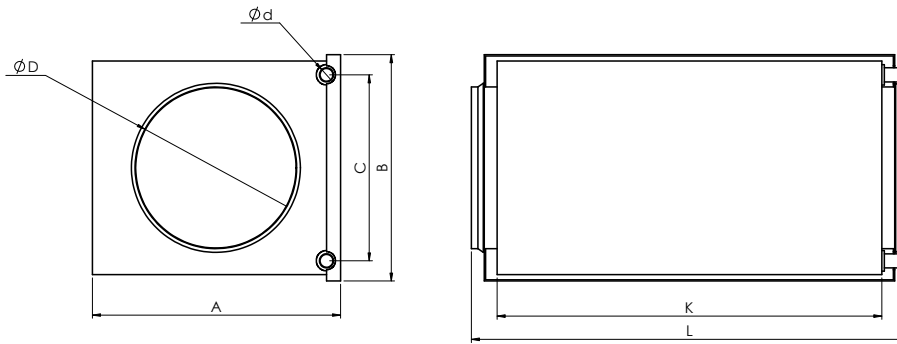

aaa	A	B	C	K	L	Ø D cm	Ø d (mm)
031	460	408	365	300	380	315	22
040	540	483	420	300	440	400	22

*] no of tube rows = 42

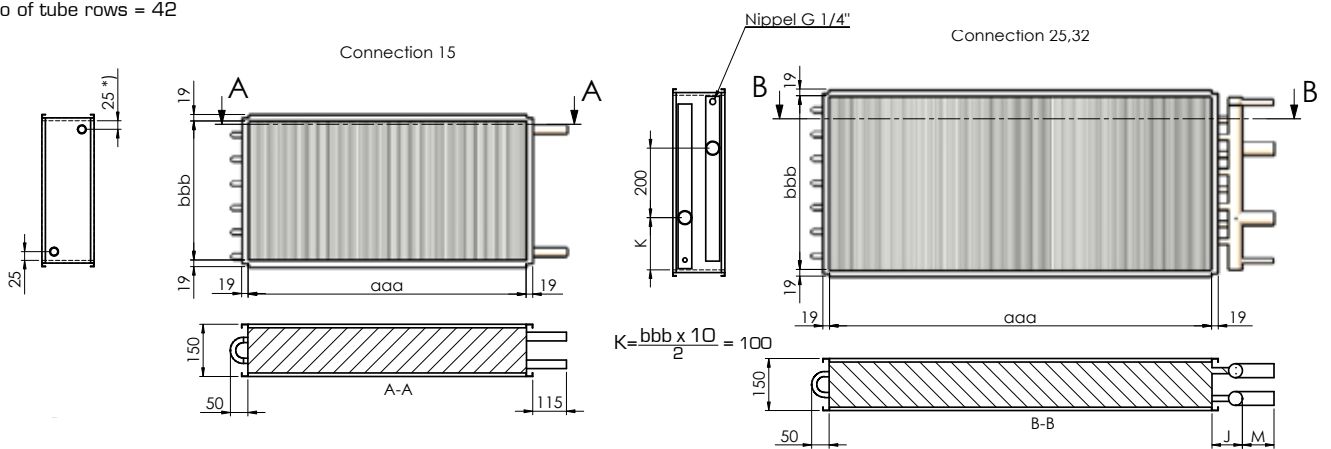

-aaa	-bbb	Output variant Cap. Var.	Conn. Output variant 1	Conn. output variant 2
080	040	1,2	15	25
110	050	1,2	25	25
140	060	1,2	25	25
140	080	1,2	25	25
170	080	1,2	25	25
200	080	1,2	25	32
200	100	1,2	32	32

Dimensions and weights (mm and kg)

EQKN, EQKP Air cooler, mounted in duct work

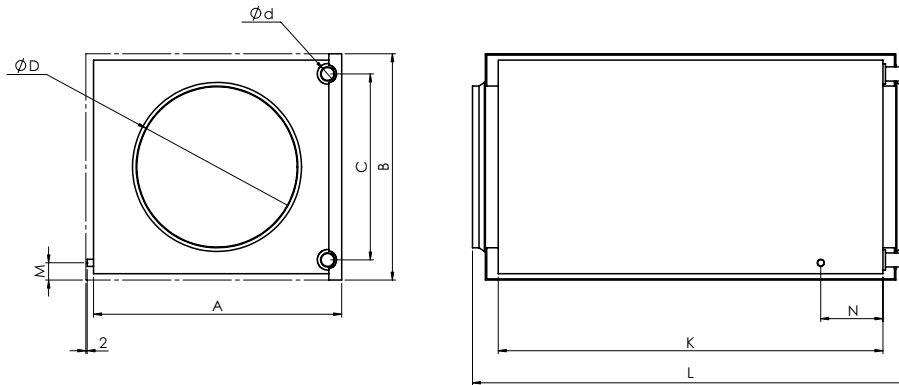

aaa	A	B	C	K	L	M	N	Ø D cm	Ø d (mm)
040	690	536	425	335	475	39	114	400	22
050	690	536	425	335	475	39	114	500	22

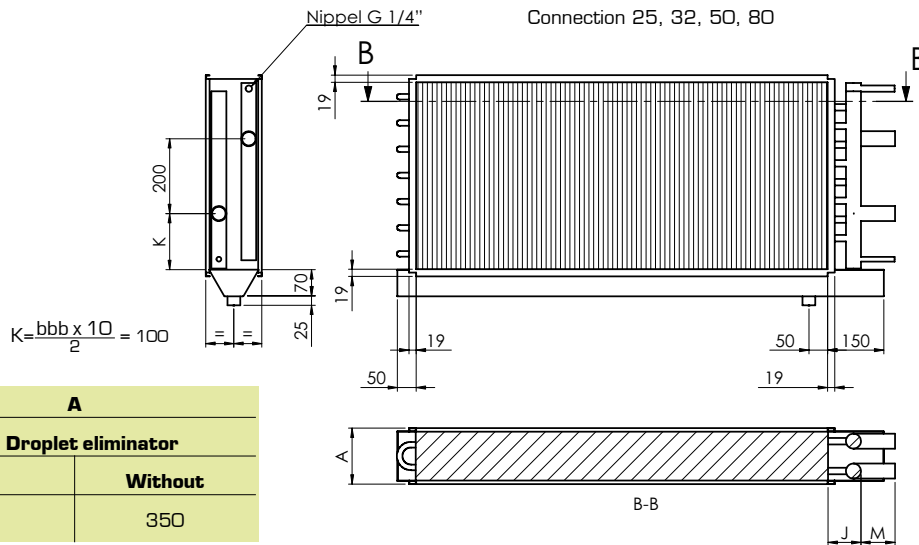

A	
Droplet eliminator	
With	Without
300	350

-aaa	-bbb	Output variant Cap. Var.	Conn. Output variant 1	Conn. Output variant 2
080	040	1,2	25	25
110	050	1,2	25	32
140	060	1,2	32	50
140	080	1,2	50	50
170	080	1,2	50	50
200	080	1,2	50	50
200	100	1,2	50	80
240	100	1,2	80	80

Dimensions and weights (mm and kg)

EQVA Casing end wall
Unit size 005-090, c=1, c=5

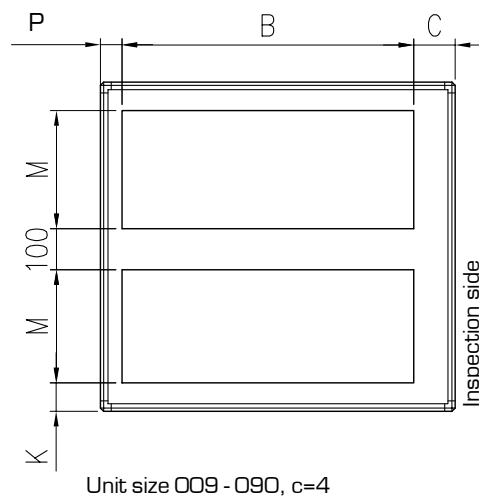
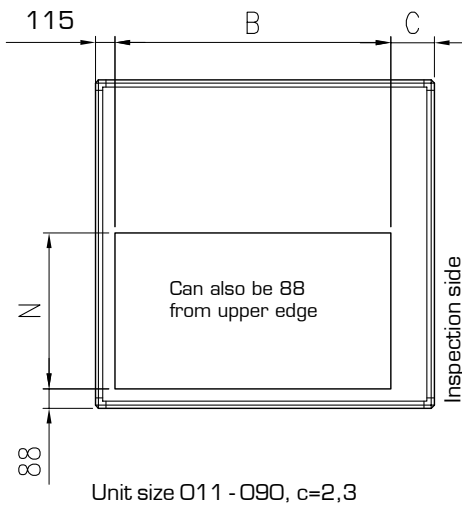
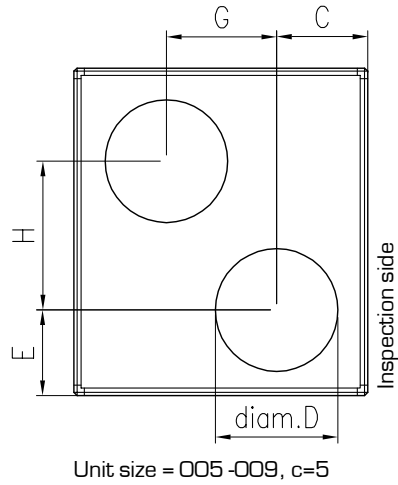
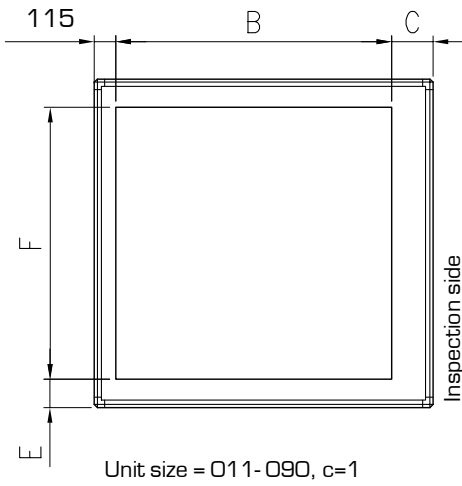

Dimensions and weights (mm and kg)

EQVA Casing end wall (EQGA/EQGB, EQHA/EQHB), c=1-4, rectangular connection

Stlk	B	C	E	F	K	M	P	N	Weight, kg b=1-4			Weight, kg
									c=0	c=1.4	c=2.3	
005	500	200	88	300	-	-	-	200	4	3	-	2
008	800	200	88	400	-	-	-	300	7	5	-	3,5
009	500	200	88	600	138	200	115	400	7	4	6	3
011	800	200	138	400	91	200	200	300	9,5	4,5	7	3
014	800	200	138	500	138	200	115	300	10	4	7,5	3
018	1100	200	138	500	138	200	115	300	13	5	10	3,5
020	800	200	138	800	88	400	115	400	14,5	5	10	3,5
023	1400	200	163	600	113	300	115	400	20	9	14	6
027	1100	200	138	800	88	400	115	500	19	6	11	4
032	1400	200	113	800	63	400	200	500	23,5	6,5	13	7
036	1100	200	188	1000	238	400	115	600	25	8,5	18,5	5,5
041	1700	200	138	800	88	400	115	400	27,5	7	17	5
045	1400	200	188	1000	238	400	115	600	30,5	9,5	22	6,5
050	2000	200	213	800	163	400	115	500	37	17	26	10,5
054	1700	200	188	1000	238	400	115	600	36	12	26,5	7,5
056	1400	200	238	1200	188	600	115	800	38	15	26	8,5
063	2000	200	188	1000	238	400	115	600	42	14	30,5	8
068	1700	200	238	1200	188	600	115	800	45	17	30,5	9,5
072	2200	200	188	1000	238	400	200	600	48	21	36,5	12
079	2000	200	238	1200	188	600	115	800	52	19	35	10,5
090	2200	300	138	1400	138	600	200	800	59	20	42	11,5

EQVA Casing end wall (EQHA), c=5, round connection

Size	C	D	E	G	H	Weight, kg
005	250	Ø315	238	300	476	3,5
008	350	Ø400	288	400	576	6
009	450	Ø500	388	-	776	5

Dimensions and weights (mm and kg)

EQVT Connection frame full area

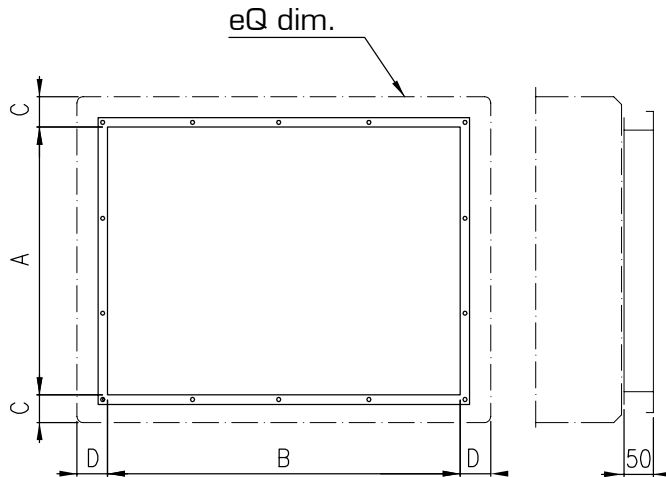

Size	A	B	C	D	Weight, kg
005	400	600	38	100	3
008	500	1000	38	50	5
009	600	600	88	100	5
011	600	1000	38	100	6
014	600	1000	88	50	6
018	600	1300	88	50	7
020	1000	1000	38	50	5
023	800	1600	63	50	6
027	1000	1300	38	50	6
032	800	1600	113	100	6
036	1200	1300	88	50	8
041	1000	1800	38	100	9
045	1200	1600	88	50	10
050	1000	2200	113	50	12
054	1200	1800	88	100	12
056	1600	1600	38	50	9
063	1200	2200	38	50	12
068	1600	1800	38	100	11
072	1200	2400	88	100	13
079	1600	2200	38	50	12
090	1600	2400	38	100	13

Dimensions and weights (mm and kg)

EQAZ-O4 Base frame

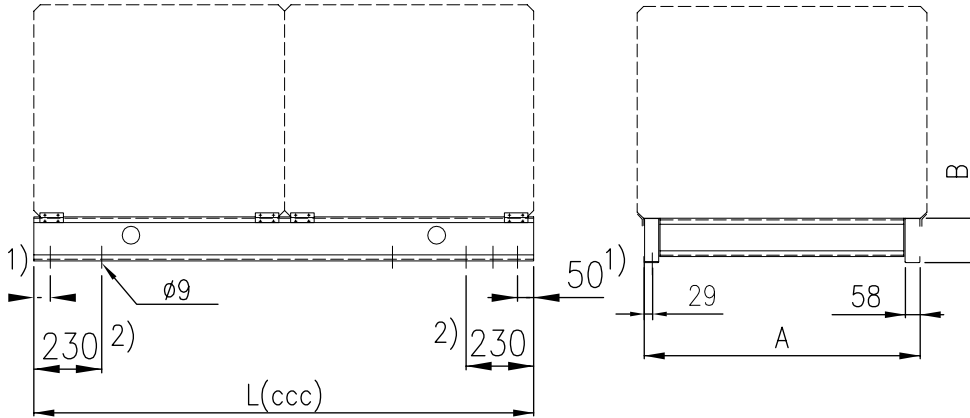

L(ccc) = 300 mm min. – 9600 mm max.
 in step of 50 mm.
 1) Holes for the adjustable feet. (d=1,2)
 2) Existing holes for L=500_9600 mm. (d=1,2)

d	B
1	150
2	300
3	200

Unit size	Weight, kg					Width
	030-065	070-105	110-225	230-550	600-960	A
005,009	0.30 x ccc	0.22 x ccc	0.20 x ccc	0.20 x ccc	0.17 x ccc	774
008,014,020	0.40 x ccc	0.25 x ccc	0.21 x ccc	0.20 x ccc	0.18 x ccc	1074
011	0.40 x ccc	0.30 x ccc	0.23 x ccc	0.23 x ccc	0.19 x ccc	1174
018,027,036	0.45 x ccc	0.33 x ccc	0.26 x ccc	0.25 x ccc	0.20 x ccc	1374
023,045,056	0.60 x ccc	0.38 x ccc	0.30 x ccc	0.27 x ccc	0.24 x ccc	1674
032	0.65 x ccc	0.43 x ccc	0.31 x ccc	0.29 x ccc	0.26 x ccc	1774
041,054,068	0.70 x ccc	0.46 x ccc	0.34 x ccc	0.30 x ccc	0.27 x ccc	1974
050,063,079	0.80 x ccc	0.50 x ccc	0.38 x ccc	0.33 x ccc	0.28 x ccc	2274
072,090	0.90 x ccc	0.52 x ccc	0.40 x ccc	0.35 x ccc	0.29 x ccc	2574

Dimensions and weights (mm and kg)

EQAZ-12 Damper

h=0

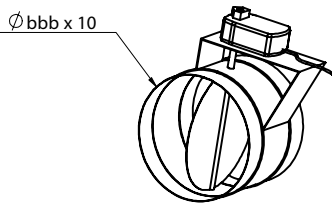

h=1

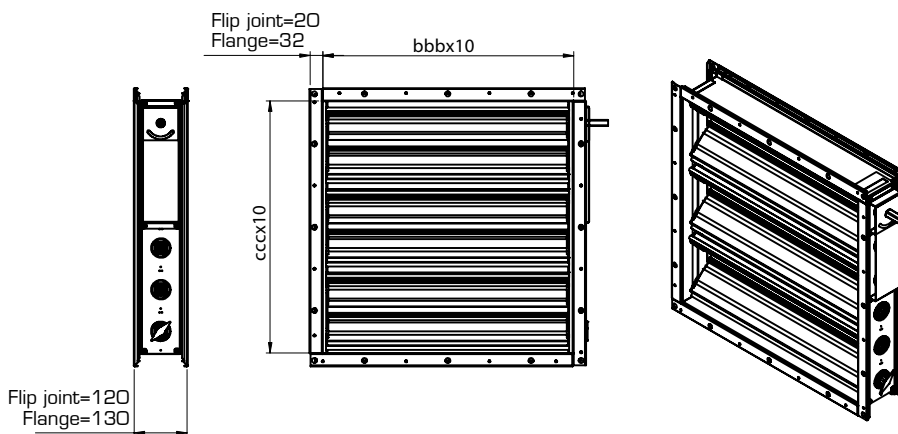

h=2

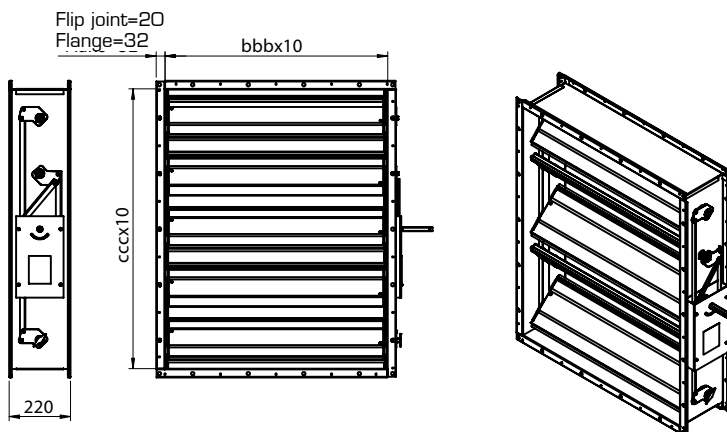

Dimensions and weights (mm and kg)

EQAZ-12 Damper

Weight circular damper		
	Damper only	With damper motor
031	2	7,3
040	3,7	10,7
050	5	13,3

Weight 100 mm damper						
ccc						
		020	030	040	050	060
	020	4.5	5.1	6.5	7	7.6
	030	5.1	6.5	8	9	10
	040	6.5	8	9	10.5	12
	050	7	9	10.5	12	14
	060	7.6	10	12	14	16
	070	8.5	11	13.5	16	17
	080	9.2	12	14.5	17	19.5
	090	10	13	16	19	22
	100	11	14	17	20	23
	110	11.5	15	18	21.5	24
	120	12	16	19	23	25
	130	13	17	20	24	27
	140	15.5	18	22	25	29

Weight 200 mm damper														
ccc														
bbb		020	030	040	050	060	080	100	120	140	160	180	200	
		020	4,5	5,5	6,5	7	7,5	9	10,5	12	13,5	14	16	17,5
		030	5	6	7	8,5	10	12	14	17	19	19,5	20	22
		040	6,5	7,5	9	11	12,5	14	17	19	21	23	25	26
		050	7	9	10,5	13	16	18	20	23	26	28	30	34
		060	8	10	12	14	18	20	23	26	30	32	34	38
		070	8,5	11	13,5	15	19	22	25	28	33	35	38	42
		080	9	12	15	17	19,5	23	27	30	36	39	42	46
		090	9,5	13	16	18	21	24	30	34	38	42	47	50
		100	10,5	14	17	20	22,5	26	33	36	40	45	50	54
		110	11	15	18	21	23,5	29	36	40	44	49	54	58
		120	12	16	20	22,5	25	31	37	42	47	52	57	62
		130	12,5	17	21	23,5	26,5	33	39	45	52	57	62	65
		140	13	18	22	24	28	35	41	48	56	61	65	70
		150	13,5	19	23,5	26	30	37	43	52	59	65	72	76
	160	14	19,5	24	28	33	39	45	55	63	68	76	79	
	170	14,5	20	24,5	29	34	41	47	57	65	72	78	82	
	180	16	20,5	25	30	35	43	50	58	66	75	80	88	
	190	17	21	26,5	32	36,5	45	54	62	69	78	84	95	
	200	18	22	28	34	38	48	56	65	72	77	88	100	
	220	18	23	30	35	40	50	58	67	76	90	95	110	

Dimensions and weights (mm and kg)

EQAZ-25 Flexible connection

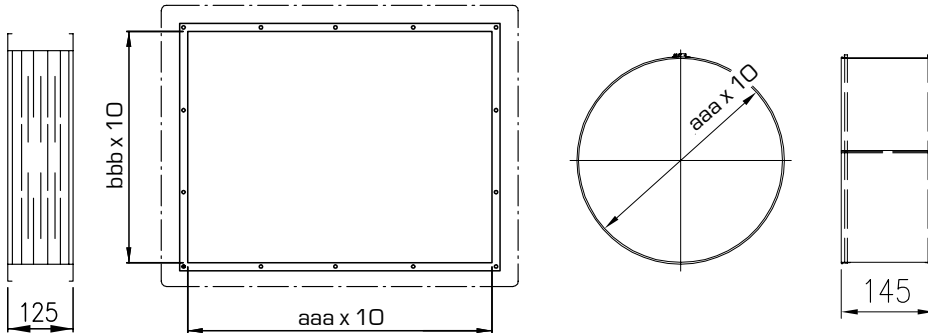

	Width bbb																					
Height aaa	020	025	030	040	050	060	070	080	090	100	110	120	130	140	150	160	170	180	190	200	210	220
020	2	2	2	3	3	3	4	4	4	5	5	5	6	6	6	7	7	8	8	8	9	9
025	2	2	2	3	3	3	4	4	5	5	5	6	6	6	7	7	7	8	8	8	9	9
030	2	2	3	3	3	4	4	4	5	5	5	6	6	6	7	7	8	8	8	9	9	9
040	3	3	3	3	4	4	4	5	5	5	6	6	6	7	7	8	8	8	9	9	9	10
050	3	3	3	4	4	4	5	5	5	6	6	6	7	7	8	8	8	9	9	9	10	10
060	3	3	4	4	4	5	5	5	6	6	6	7	7	8	8	8	9	9	9	10	10	10
070	4	4	4	4	5	5	5	6	6	6	7	7	8	8	8	9	9	9	10	10	10	11
080	4	4	4	5	5	5	6	6	6	7	7	8	8	8	9	9	9	10	10	10	11	11
090	4	5	5	5	5	6	6	6	7	7	8	8	8	9	9	9	10	10	10	11	11	11
100	5	5	5	5	6	6	6	7	7	8	8	8	9	9	9	10	10	10	11	11	11	12
110	5	5	5	6	6	6	7	7	8	8	8	9	9	9	10	10	10	11	11	11	12	12
120	5	6	6	6	6	7	7	8	8	8	9	9	9	10	10	10	11	11	11	12	12	12
130	6	6	6	6	7	7	8	8	8	9	9	9	10	10	10	11	11	11	12	12	12	13
140	6	6	6	7	7	8	8	8	9	9	9	10	10	10	11	11	11	12	12	12	13	13
150	6	7	7	7	8	8	8	9	9	9	10	10	10	11	11	11	12	12	12	13	13	13
160	7	7	7	8	8	8	9	9	9	10	10	10	11	11	11	12	12	12	13	13	13	14
170	7	7	8	8	8	9	9	9	10	10	10	11	11	11	12	12	12	13	13	13	14	14
180	8	8	8	8	9	9	9	10	10	10	11	11	11	12	12	12	13	13	13	14	14	15
190	8	8	8	9	9	9	10	10	10	11	11	11	12	12	12	13	13	13	14	14	15	15
200	8	8	9	9	9	10	10	10	11	11	11	12	12	12	13	13	13	14	14	15	15	15
210	9	9	9	9	10	10	10	11	11	11	12	12	12	13	13	13	14	14	15	15	15	16
220	9	9	9	10	10	10	11	11	11	12	12	12	13	13	13	14	14	15	15	15	16	16

Weight, kg.

Circular connections		
aaa	Diameter	Weight, kg
031	315	1
040	400	2
050	500	3

Dimensions and weights (mm and kg)

EQAZ-26 Duct connection piece

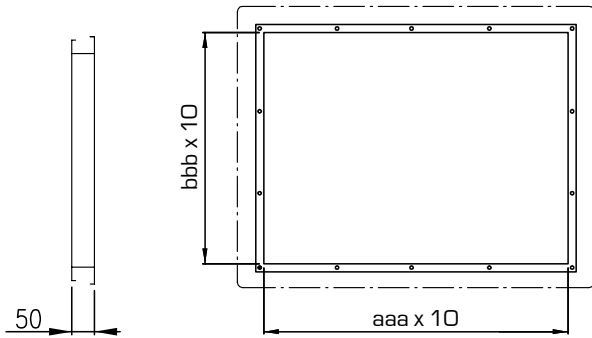

	Width bbb																					
Height aaa	020	025	030	040	050	060	070	080	090	100	110	120	130	140	150	160	170	180	190	200	210	220
020	2	2	2	2	2	3	3	3	3	4	4	4	5	5	5	6	6	6	6	7	7	
025	2	2	2	2	3	3	3	3	4	4	4	4	5	5	5	6	6	6	6	7	7	7
030	2	2	2	2	3	3	3	3	4	4	4	5	5	5	6	6	6	6	7	7	7	7
040	2	2	2	3	3	3	3	4	4	4	5	5	5	6	6	6	6	7	7	7	7	7
050	2	3	3	3	3	3	4	4	4	5	5	5	5	6	6	6	6	7	7	7	7	8
060	3	3	3	3	3	4	4	4	5	5	5	5	6	6	6	6	7	7	7	7	8	8
070	3	3	3	3	4	4	4	5	5	5	5	6	6	6	6	7	7	7	7	8	8	8
080	3	3	3	4	4	4	5	5	5	5	6	6	6	6	7	7	7	7	8	8	8	9
090	3	4	4	4	4	5	5	5	5	6	6	6	6	7	7	7	7	8	8	8	9	9
100	4	4	4	4	5	5	5	5	6	6	6	6	7	7	7	7	8	8	8	9	9	9
110	4	4	4	5	5	5	5	6	6	6	6	7	7	7	7	8	8	8	9	9	9	9
120	4	4	5	5	5	5	6	6	6	6	7	7	7	7	8	8	8	9	9	9	9	10
130	5	5	5	5	5	6	6	6	6	7	7	7	7	8	8	8	9	9	9	9	10	10
140	5	5	5	5	6	6	6	6	7	7	7	7	8	8	8	9	9	9	9	10	10	10
150	5	5	5	6	6	6	6	7	7	7	7	8	8	8	9	9	9	9	10	10	10	10
160	5	5	6	6	6	6	7	7	7	7	8	8	8	9	9	9	9	10	10	10	10	11
170	6	6	6	6	6	7	7	7	7	8	8	8	9	9	9	9	10	10	10	10	11	11
180	6	6	6	6	7	7	7	7	8	8	8	9	9	9	9	10	10	10	10	11	11	11
190	6	6	6	7	7	7	7	8	8	8	9	9	9	9	10	10	10	10	11	11	11	11
200	6	7	7	7	7	7	8	8	8	9	9	9	9	10	10	10	10	11	11	11	11	12
210	7	7	7	7	7	8	8	8	9	9	9	9	10	10	10	10	11	11	11	11	12	12
220	7	7	7	7	8	8	8	9	9	9	9	10	10	10	10	11	11	11	11	12	12	12

Weight, kg.

Dimensions and weights (mm and kg)

EQAZ-27 Counter-flange

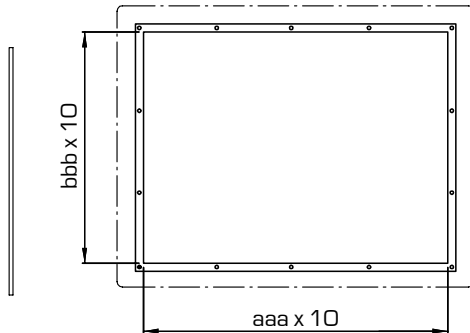

	Width bbb																					
Height aaa	020	025	030	040	050	060	070	080	090	100	110	120	130	140	150	160	170	180	190	200	210	220
020	2	2	2	2	2	3	3	3	4	4	4	4	5	5	5	6	6	6	6	7	7	7
025	2	2	2	2	3	3	3	3	4	4	4	5	5	5	5	6	6	6	7	7	7	7
030	2	2	2	2	3	3	3	4	4	4	4	5	5	5	6	6	6	6	7	7	7	8
040	2	2	2	3	3	3	4	4	4	4	5	5	5	6	6	6	6	7	7	7	8	8
050	2	3	3	3	3	4	4	4	4	5	5	5	6	6	6	6	7	7	7	8	8	8
060	3	3	3	3	4	4	4	4	5	5	5	6	6	6	6	7	7	7	8	8	8	8
070	3	3	3	4	4	4	4	5	5	5	6	6	6	6	7	7	7	8	8	8	8	9
080	3	3	4	4	4	4	5	5	5	6	6	6	6	7	7	7	8	8	8	8	9	9
090	4	4	4	4	4	5	5	5	6	6	6	6	7	7	7	8	8	8	8	9	9	9
100	4	4	4	4	5	5	5	6	6	6	6	7	7	7	8	8	8	8	9	9	9	10
110	4	4	4	5	5	5	6	6	6	6	7	7	7	8	8	8	8	9	9	9	10	10
120	4	5	5	5	5	6	6	6	6	7	7	7	8	8	8	8	9	9	9	10	10	10
130	5	5	5	5	6	6	6	6	7	7	7	8	8	8	8	9	9	9	10	10	10	10
140	5	5	5	6	6	6	6	7	7	7	8	8	8	8	9	9	9	10	10	10	10	11
150	5	5	6	6	6	6	7	7	7	8	8	8	8	9	9	9	10	10	10	10	11	11
160	6	6	6	6	6	7	7	7	8	8	8	8	9	9	9	10	10	10	10	11	11	11
170	6	6	6	6	7	7	7	8	8	8	8	9	9	9	10	10	10	10	11	11	11	11
180	6	6	6	7	7	7	8	8	8	8	9	9	9	10	10	10	10	11	11	11	11	12
190	6	7	7	7	7	8	8	8	8	9	9	9	10	10	10	10	11	11	11	11	12	12
200	7	7	7	7	8	8	8	8	9	9	9	10	10	10	10	11	11	11	11	12	12	12
210	7	7	7	8	8	8	8	9	9	9	10	10	10	10	11	11	11	11	12	12	12	13
220	7	7	8	8	8	8	9	9	9	10	10	10	10	11	11	11	11	12	12	12	13	13
Weight, kg.																						

Dimensions and weights (mm and kg)

EQAZ-28 Protective screen

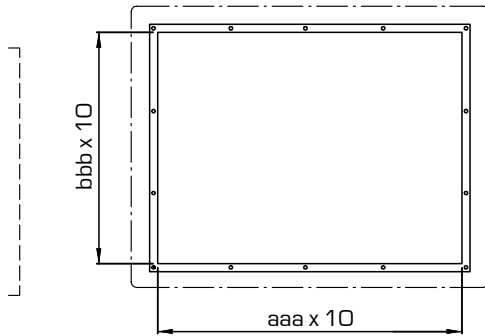

	Width bbb																					
Height aaa	020	025	030	040	050	060	070	080	090	100	110	120	130	140	150	160	170	180	190	200	210	220
020	2	2	2	2	3	3	3	4	4	4	4	5	5	5	6	6	6	7	7	7	7	8
025	2	2	2	2	3	3	3	4	4	4	5	5	5	5	6	6	6	7	7	7	8	8
030	2	2	2	3	3	3	4	4	4	4	5	5	5	6	6	6	7	7	7	7	8	8
040	2	2	3	3	3	4	4	4	4	5	5	5	6	6	6	7	7	7	7	8	8	8
050	3	3	3	3	4	4	4	4	5	5	5	6	6	6	7	7	7	7	8	8	8	9
060	3	3	3	4	4	4	4	5	5	5	6	6	6	7	7	7	7	8	8	8	9	9
070	3	3	4	4	4	4	5	5	5	6	6	6	7	7	7	7	8	8	8	9	9	9
080	4	4	4	4	4	5	5	5	6	6	6	7	7	7	7	8	8	8	9	9	9	10
090	4	4	4	4	5	5	5	6	6	6	7	7	7	7	8	8	8	9	9	9	10	10
100	4	4	4	5	5	5	6	6	6	7	7	7	7	8	8	8	9	9	9	10	10	10
110	4	5	5	5	5	6	6	6	7	7	7	7	8	8	8	9	9	9	10	10	10	10
120	5	5	5	5	6	6	6	7	7	7	7	8	8	8	9	9	9	10	10	10	10	11
130	5	5	5	6	6	6	7	7	7	7	8	8	8	9	9	9	10	10	10	10	11	11
140	5	5	6	6	6	7	7	7	7	8	8	8	9	9	9	10	10	10	10	11	11	11
150	6	6	6	6	7	7	7	7	8	8	8	9	9	9	10	10	10	10	11	11	11	12
160	6	6	6	7	7	7	7	8	8	8	9	9	9	10	10	10	10	11	11	11	12	12
170	6	6	7	7	7	7	8	8	8	9	9	9	10	10	10	10	11	11	11	12	12	12
180	7	7	7	7	7	8	8	8	9	9	9	10	10	10	10	11	11	11	12	12	12	13
190	7	7	7	7	8	8	8	9	9	9	10	10	10	10	11	11	11	12	12	12	13	13
200	7	7	7	8	8	8	9	9	9	10	10	10	10	11	11	11	12	12	12	13	13	13
210	7	8	8	8	8	9	9	9	10	10	10	10	11	11	11	12	12	12	13	13	13	13
220	8	8	8	8	9	9	9	10	10	10	10	11	11	11	12	12	12	13	13	13	13	14
Weight, kg.																						

Dimensions and weights (mm and kg)

EQBZ-01 Roof

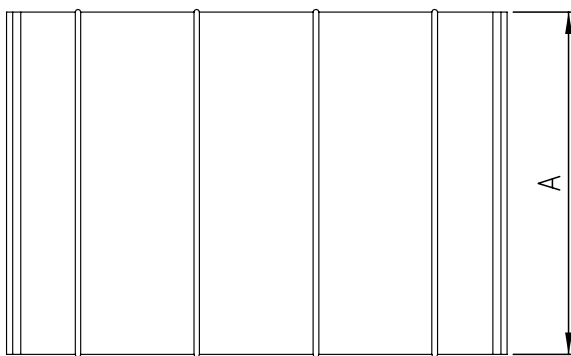
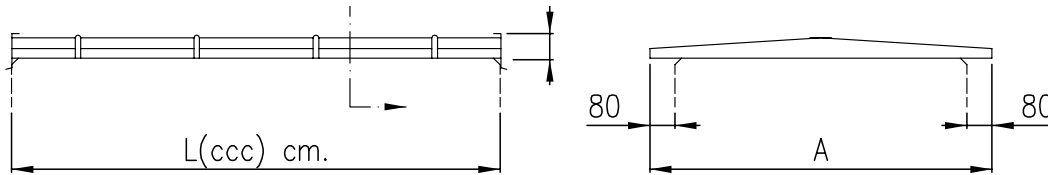

L(ccc) = 200 mm min. – 9600 mm max.
in steps of 50 mm.

	Width	
Size	A	Weight, kg
005,009	960	0,12 x ccc + 6
008,014,020	1260	0,15 x ccc + 8
011	1360	0,16 x ccc + 9
018,027,036	1560	0,17 x ccc + 10
023,045,056	1860	0,19 x ccc + 12
032	1960	0,20 x ccc + 13
041,054,068	2160	0,22 x ccc + 14
050,063,079	2460	0,25 x ccc + 16
072,090	2760	0,27 x ccc + 17

Dimensions and weights (mm and kg)

EQBZ-09 Louvered shutter

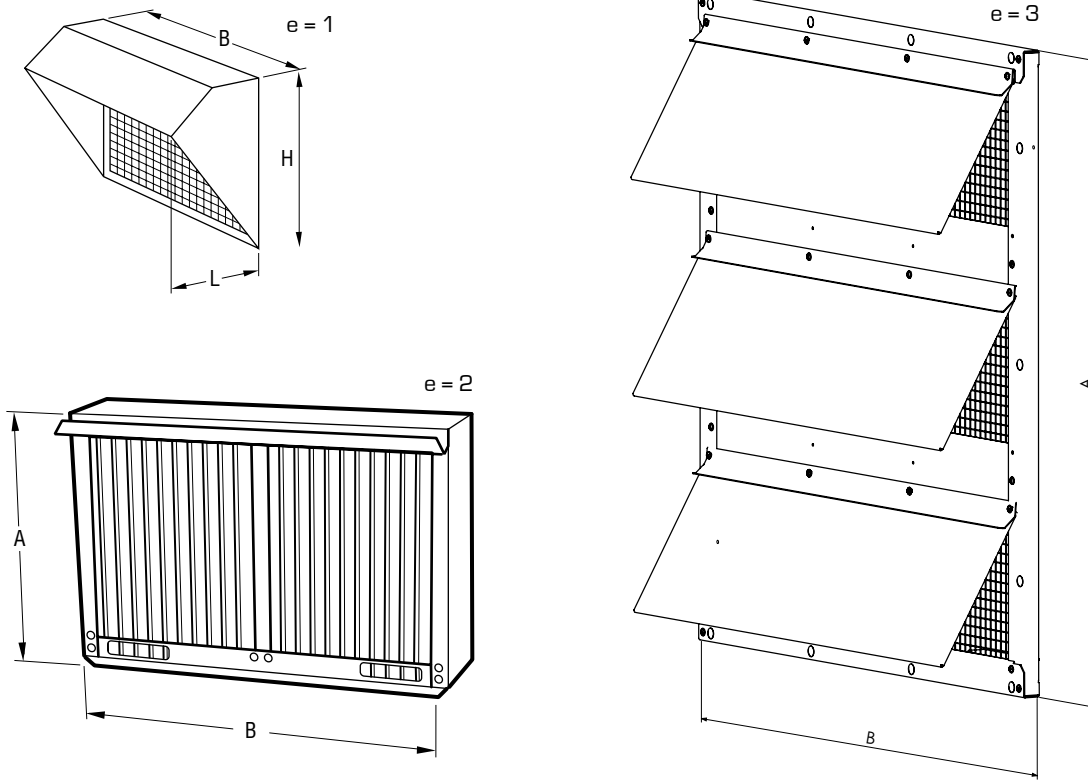

Size	Dimensions							Weight, kg		
	B	L	H	e=2		e=3		e=1	e=2	e=3
005						396	564	8	9	5
008	1000	355	325	505	840	496	864	10	14	5
009	700	400	550	705	540	696	564	11	20	5
011	1100	400	550	505	840	496	864	14	20	5
014	1000	400	550	605	840	596	864	26,8	24	5
018	1300	400	550	605	1140	596	1164	16	29	10
020	1000	550	750	905	840	896	864	15,9	31	10
023	1600	550	750	705	1440	696	1464	21	35	10
027	1300	550	750	905	1140	896	1164	18,4	41	10
032	1700	550	750	905	1440	896	1464	21,8	43	10
036	1300	690	950	1105	1140	1096	1164	25	50	15
041	1900	550	750	905	1740	896	1764	23,5	60	10
045	1600	690	950	1105	1440	1096	1464	28,2	60	15
050	2200	690	950	905	2040	896	2064	44	66	20
054	1900	690	950	1105	1740	1096	1764	29,2	76	20
056	1600	850	1150	1305	1440	1296	1464	37,5	75	20
063	2200	950	950	1105	2040	1096	2064	34,5	88	20
068	1900	850	1150	1305	1740	1296	1764	41,5	88	25
072	2500	690	950	1105	2240	1096	2264	37,7	97	20
079	2200	850	1150	1305	2040	1296	2064	45,4	105	25
090	2500	850	1150	1505	2240	1495	2264	49,4	135	25

Dimensions and weights (mm and kg)

EQLZ-02 Outdoor adaption

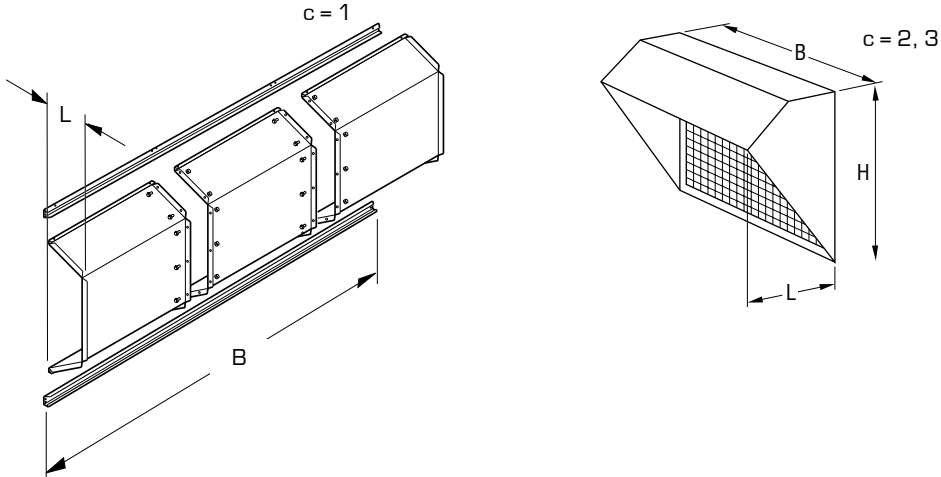

c=1 Side discharge			
Size	B	L	Weight, kg
005	770	120	6
008	1070	170	12
009	770	170	6
011	1170	170	14
014	1070	195	13
018	1370	280	16
020	1070	220	15
023	1670	220	17
027	1370	220	15
032	1770	280	30
036	1370	280	20
041	1970	280	37
045	1670	280	27
050	2270	310	50
054	2270	310	50
056	1670	310	29
063	2270	310	50
068	1970	335	40
072	2570	310	60
079	2270	335	55
090	2570	410	70

c=2 Outdoor adaption for EQLR				
Size	B	L	H	Weight, kg
005				
008				
009	456	400	450	9
011				
014	656	400	550	11
018				
020	656	550	650	14
023				
027	756	550	750	17
032				
036				
041				
045	956	690	950	25
050				
054				
056				
063	1056	690	1050	34
068				
072				
079	1156	1150	850	38
090				

c=3 Outdoor adaption for EQLK				
Size	B	L	H	Weight, kg
005				8
008	1000	355	325	10
009	700	400	550	11
011	1100	400	550	14
014	1000	400	550	26,8
018	1300	400	550	16
020	1000	550	750	15,9
023	1600	550	750	21
027	1300	550	750	18,4
032	1700	550	750	21,8
036	1300	690	950	25
041	1900	550	750	23,5
045	1600	690	950	28,2
050	2200	690	950	44
054	1900	690	950	29,2
056	1600	850	1150	37,5
063	2200	950	950	34,5
068	1900	850	1150	41,4
072	2500	690	950	37,7
079	2200	850	1150	45,4
090	2500	850	1150	49,4



Dimensions and weights (mm and kg)

EQLZ-25 Telpher beam

Size	Weight, kg
008, 014, 020	11
011	12
018, 027, 036	15
023, 045, 056	18
032	19
041, 054	23
047, 050, 063	26
072	30
068	52
079	60
090	68

EQLZ-25 Telpher

Size	Weight, kg
068, 079, 090	70

For length, see product selection tool ACON.

Product code

How to read the product code

Some of the product codes will be released later in 2010.

Some products are completely in the eQ PLUS range. Their codes has a italic green heading that ends with (eQ PLUS).

The products available in the eQ range often have alternatives in the eQ PLUS range. When only parts of the code is included in the eQ PLUS range, they are written in green italic.

Example:

HEPA filter (eQ PLUS)

(filter cassettes excluded)

EQPF-aaa-bb-c-d-1

Unit size (aaa)

005, 009, 014, 018, 020, 023, 027, 036, 041, 045, 047, 054-090
Only casing EQGB

Length filter section (bb)

09 = 900 mm 11 = 1100 mm
10 = 1000 mm 12 = 1200 mm

Location (c)

1 = supply air (overpressure)
2 = exhaust air (underpressure)

Inspection side (d)

1 = right
2 = left

Example:

Panel filter

EQPA-aaa-b-c-d-e-f-1

Unit size (aaa)

005-090

Filter class (b)

0 = without filter
2 = G 2
4 = G 4

Filter type (c)

0 = without filter
1 = aluminium, cleanable (only b=2)
2 = synthetic, cleanable (only b=4)

Drip tray (d)

0 = without
1 = with (with drainage)
2 = with (without drainage)

Material (e)

1 = galvanized sheet steel
2 = stainless sheet steel (AISI 304)

Inspection side (f)

1 = right
2 = left

Product code

Codes in green italic are included in eQ PLUS

Casing

Unit casing (Single casing)

EQGA-aaa-bbb-cc-d-e-f-g-h-i-1

Unit size (aaa)

005-020,027,036

Length, cm (bbb)

bbb = 030 - 280 in step by 5 cm

Panel material outer/inner (cc)

11 = aluzinc coated sheet steel, 0.7 mm.

22 = *aluzinc coated sheet steel, 0.9 mm*

32 = *outside galvanized sheet steel coated with polyester 0.9 mm. Inside aluzinc coated sheet steel 0.9 mm.*

33 = galvanized sheet steel coated with polyester, 0.9 mm, Class M3 outer.

34 = *outside galvanized sheet steel coated with polyester 0.9 mm. Inside galvanised sheet steel 0.7 mm (AISI 304).*

44 = *stainless sheet steel 0.7 mm (AISI 304)*

Insulation (d)

1 = mineral wool in panel: standard

4 = mineral wool in panel: heavy

Version (e)

1 = horizontal

2 = *vertical (aaa = 005-011)*

Tightness class (f)

2 = CEN B *)

Anti-condensation insulation (g)

1 = standard (TB3)

Configuration (h)

1 = complete unit

2 = first multi-function block

3 = intermediate multi-function block

4 = last multi-function block

Casing version (i)

1 = indoor version

2 = outdoor version

Unit casing (Single casing)

EQGB-aaa-bbb-cc-d-e-f-g-h-i-1

Unit size (aaa)

023,032,041-054, 063,072

005-090

Length, cm (bbb)

bbb = 030 - 320 in step by 5 cm

(aaa = 108, 126, 144 leads to bbb=030-600)

Panel material outer/inner (cc)

11 = aluzinc coated sheet steel, 0.7 mm.

22 = *aluzinc coated sheet steel, 0.9 mm*

32 = *outside galvanized sheet steel coated with polyester 0,9 mm. Inside aluzinc coated sheet steel 0,9 mm.*

33 = galvanized sheet steel coated with polyester, 0,9 mm, Class M3 outer.

34 = *outside galvanized sheet steel coated with polyester 0.9 mm. Inside galvanised sheet steel 0.7 mm (AISI 304).*

44 = *stainless sheet steel 0.7 mm (AISI 304)*

Insulation (d)

1 = mineral wool in panel: standard

4 = mineral wool in panel: heavy

Version (e)

1 = horizontal

2 = *vertical (aaa = 005-011)*

Tightness class (f)

2 = CEN B *)

Anti-condensation insulation (g)

1 = standard (TB3)

2 = *TB2**

Configuration (h)

1 = complete unit

2 = first multi-function block

3 = intermediate multi-function block

4 = last multi-function block

Casing version (i)

1 = indoor version

2 = outdoor version

3 = *hygiene indoor*

4 = *hygiene outdoor*

*) Applies to casing and internally mounted functions.

Product code

Codes in green italic are included in eQ PLUS

Unit casing (Double casing)

EQHA-aaa-bbb-cc-d-e-f-g-h-i-1

Unit size (aaa)

005,008,011,018

005-018

Length, cm (bbb)

bbb = 030 - 280 in steps by 5 cm

Panel material outer / inner (cc)

11 = aluzinc coated sheet steel, 0.7 mm.

32 = outside galvanized sheet steel coated with polyester 0.9 mm. Inside aluzinc coated sheet steel 0.9 mm.

33 = galvanized sheet steel coated with polyester, 0.9 mm, Class M3 outer.

34 = outside galvanized sheet steel coated with polyester 0.9 mm. Inside galvanised sheet steel 0.7 mm (AISI 304).

44 = stainless sheet steel 0.7 mm (AISI 304)

Insulation (d)

1 = mineral wool in panel: standard

4 = mineral wool in panel: heavy

5 = corresponding EI 15 mineral wool

8 = corresponding EI 30 mineral wool heavy

Version (e)

1 = horizontal

2 = vertical (aaa = 005-011)

Tightness class (f)

2 = CEN B *

Anti- condensation insulation (g)

1 = standard (TB3)

Configuration (h)

1 = complete unit

2 = first multi-function block

3 = intermediate multi-function block

4 = last multi-function block

5 = REGOTERM® block, double floor . aaa=009, 014

Casing version (i)

1 = indoor version

2 = outdoor version

Unit casing (Double casing)

EQHB-aaa-bbb-cc-d-e-f-g-h-i-1

Unit size (aaa)***

023,032,041,050,072**

005-032, 041, 050

** Only for EQKA, EQRA, EQRC, EQRF, EQRT

*** For EQKA with size 005, 008, 011, 018, 023, 032, 041, 050, 072

Length, cm (bbb)

bbb = 030 - 320 in steps by 5 cm

Panel material outer/inner (cc)

11 = aluzinc coated sheet steel, 0,7 mm.

32 = outside galvanized sheet steel coated with polyester 0.9 mm. Inside aluzinc coated sheet steel 0.9 mm.

33 = galvanized sheet steel coated with polyester, 0.9 mm, Class M3 outer.

34 = outside galvanized sheet steel coated with polyester 0.9 mm. Inside galvanised sheet steel 0.7 mm (AISI 304).

44 = stainless sheet steel 0.7 mm (AISI 304)

Insulation (d)

1 = mineral wool in panle: standard

4 = mineral wool in panle: heavy

5 = corresponding EI 15 mineral wool

8 = corresponding EI 30 mineral wool heavy

Version (e)

1 = horizontal

2 = vertical (aaa = 005-011)

Tightness class (f)

2 = CEN B *)

Anti- condensation insulation (g)

1 = standard (TB3)

2 = TB2 for heat exchangers*

Configuration (h)

1 = complete unit

2 = first multi-function block

3 = intermediate multi-function block

4 = last multi-function block

5 = REGOTERM®, double floor (020, 027, 036, 045, 054-090)

6 = intermediate multi-function block with Cooler function (005,008,011,018,023,032,041,050,072)

7 = REGOTERM® double floor separate casing

version (i)

1 = indoor version

2 = outdoor version

*Applies to casing and internally mounted functions.

Product code

Codes in green italic are included in eQ PLUS

Factory installed unit on common base frame

EQGM-a-bbb-ccc-ddd-e-1

Number of floors (a)

1,2

Size of lower floor (bbb)

005-090

Size of upper floor (ccc)

000 (a=1)

005-090

Length of complete unit (ddd)

100 -> 960 cm

Factory-installed control (e)

0 = without

1 = with

Connection frame full area

EQVT-aaa-b-c-d-1

Unit size (aaa)

005-090

Connection (b)

1=PG

2=Flange

Frame material (c)

2 = stainless sheet steel (AISI 304)

8 = aluminum coated steel sheet

Position (d)

1=Inlet

2=Outlet

Casing end wall

EQVA-aaa-b-c-dd-e-1

Unit size (aaa)

Location (b)

1 = inlet

2 = outlet

5 = internal wall, first in airflow direction

6 = internal wall, sist i luftriktningen

Opening (c)

0 = without opening

1 = one large opening

2 = one opening in the lower part

3 = one opening in the upper part

4 = two openings

5 = round connection

Panel material inner/outer (dd)

= casing code

Inspection side (e)

1 = right

2 = left

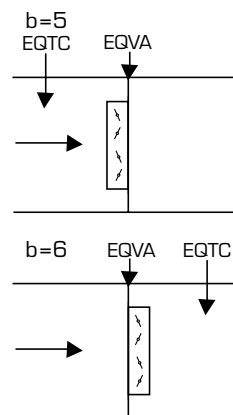

Product code

Codes in green italic are included in eQ PLUS

Joining frame (eQ PLUS)

(fitted to the larger module)

EQVH-aaa-bbb-c-dd-e-1

Unit size (aaa – bbb)

Bigger Size	Smaller size	Bigger size	Smaller size
(c = 1, 2)		(c = 3, 4)	
009	005	014	009
014	008	018	014
020	014	027	020
027	018	041	027
036	027	045	036
054	041	054	045
056	045	063	054
068	054	068	056
079	063	072	063
090	072	079	068

Location (c)

- 1 = against the ceiling
- 2 = against the base
- 3 = against the left side viewed in the airflow direction¹⁾
- 4 = against the right side viewed in the airflow direction¹⁾

Panel material outer/inner (dd)

- 11 = aluzinc coated sheet steel 0.7 mm
- 33 = polyester coated galvanized sheet steel 0.9 mm
- 44 = stainless sheet steel 0.7 mm (AISI 304)
- 34 = outside galvanized sheet steel coated with polyester 0.9 mm. Inside galvanised sheet steel 0.7 mm (AISI 304).
- 32 = outside galvanized sheet steel coated with polyester 0.9 mm, Inside AlZn sheet steel 0.9 mm

Location (e)

- 0 = on end wall inlet of the block
- 1–4 = on recovery unit: EQRA, EQRB, EQRC²⁾
- 9 = on block end outlet

¹⁾ The airflow direction of supply air for recovery units.

²⁾ From inspection side.

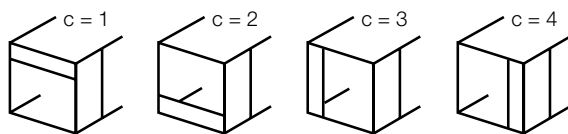

Mixing- and extract air section (eQ PLUS)

(In line)

EQVG-aaa-b-c-d-e-1

Unit size (aaa)

009-090

Block (b)

1= block one

Tightness class damper (c)

3=CEN 3

4=CEN 4

Material damper (d)

1= galvanized sheet steel

2= stainless sheet steel (AISI 304)

Inspection side (e)

1 = right

2 = left

Product code

Codes in green italic are included in eQ PLUS

Filter

Panel filter

EQPA-aaa-b-c-d-e-f-1

Unit size (aaa)

005-090

Filter class (b)

0 = without filter

2 = G 2

4 = G 4

Filter type (c)

0 = without filter

1 = aluminium, cleanable (only b=2)

2 = synthetic, cleanable (only b=4)

Drip tray (d)

0 = without

1 = with (with drainage)

2 = with (without drainage)

Material (e)

1 = galvanized sheet steel

2 = stainless sheet steel (AISI 304)

Inspection side (f)

1 = right

2 = left

Replacement filter

Filter for EQPA, set

EQPZ-01-bbb-c-d-e-1

Unit size (bbb)

005-090

Filter class (c)

2 = G 2

4 = G 4

Filter type (d)

1 = aluminium, cleanable (only c=2)

2 = synthetic, cleanable (only c=4)

Filter frame (e)

1 = galvanized sheet steel

2 = stainless sheet steel (AISI 304)

Filter mat for EQPA, set

EQPZ-02-bbb-c-d-1

Unit size (bbb)

005-090

Filter class (c)

4 = G 4

Filter type (c)

2 = synthhetic, cleanable

Product code

Codes in green italic are included in eQ PLUS

HEPA filter (eQ PLUS)

(filter cassettes excluded)

EQPF-aaa-bb-c-d-1

Unit size (aaa)

005, 009, 014, 018, 020, 023, 027, 036, 041,
045, 047, 054, 068-090

Only casing EQGB

Length filter section (bb)

09 = 900 mm 11 = 1100 mm
10 = 1000 mm 12 = 1200 mm

Location (c)

1 = supply air (overpressure) *
2 = exhaust air (underpressure)

Inspection side (d)

1 = right
2 = left

*Sizes 005 009 ,014, 018 no door for over pressure

Filter cassettes (set) for HEPA filter EQPF (eQ PLUS)

EQPZ-24-bbb-c-d-1

Unit size (bbb)

005, 009, 014, 018, 020, 023, 027, 036, 041,
045, 047, 054, 068-090

Filter type (c)

1 = H10
2 = H12
3 = H13
4 = H14

Filter cassette, material (d)

1 = plywood
2 = galvanized sheet steel
3 = stainless sheet steel

Carbon filter (eQ PLUS)

EQPK-aaa-b-c-d-1

Unit size (aaa)

005-090

Filter type (b)

0 = prepared for cylindrical insert (Camfil)

Material (c)

1 = galvanized sheet steel
2 = stainless sheet steel (AISI 304)

Inspection side (d)

1 = right
2 = left

Replacement filters (eQ PLUS)

Replacement filter for EQPK, set

EQPZ-06-bbb-c-1

Unit size (bbb)

005-090

Filter type (c)

1 = cylinder type
2 = cylindertyp impregnerad (SO₂ + H₂S)
3 = cylindertyp impregnerad (NH₃)

Product code

Codes in green italic are included in eQ PLUS

Filter

EQPB-aaa-bb-cc-d-e-f-g-h-i-j-k

Unit size (aaa)

005-090

Filter class (bb)

00 = without filter, prepared for filter

04 = G 4

05 = F 5

06 = F6

07 = F 7

08 = F8

09 = F 9

Filter type (cc)

00 = without filter, prepared for filter

01 = synthetic

02 = glass fibre

03 = compact

04 = Cityflo (glass fibre with carbon)

05 = Citycarb (compact with carbon)

22 = glass fibre, lower SFPv (d=6, e=2)

Filter length (d)

3 = Short bag (vertical pockets only)

4 = Long bag (vertical pockets only)

5 = Compact and Citycarb (e=2)

6 = Extra long bag (only cc=22)

Filter frame (e)

0 = without filter

1 = galvanized sheet steel

2 = plastic, PP

Connection side (f)

1 = inlet gable

2 = inlet in end wall, service from contaminated side

3 = inlet at the top (rectangular)

4 = inlet at the top (rectangular)

5 = inlet at the top (round)

6 = outlet at the top (round)

7 = inlet gable, withdrawable filter frame

Location (g)

1 = negative pressure

2 = positive pressure (only f=2)

Prefilter (h)

0 = without

2 = G2 50 mm wovlen aluminium cassette (f=1,2)

3 = G3 50 mm syntetic/cotton, paper cassett (f=1,2)

4 = G3 50 mm syntetic/cotton, galvanized sheet steel cassett

5 = G4 50 mm synthetic/cotton,paper cassett

6 = G4 50 mm syntetic/cotton, aluminium cassette

9 = with guide rail, without prefilter

Drain tray (i)

0 = without

1 = with (with drainage)

2 = with (without drainage)

3 = with (with draining and perforated sheet steel)

4 = with (without draining and perforated sheet steel)

Material (j)

1 = galvanized sheet steel

2 = stainless steel (AISI 304)

Inspection side (k)

1 = right

2 = left

Product code

Codes in green italic are included in eQ PLUS

Replacement filter

Filter for EQPB set **EQPZ-03-bbb-cc-dd-e-f-1**

Unit size (bbb)
005-090

Filter class (cc)
04 = G 4
05 = F 5
06 = F 6
07 = F 7
08 = F 8
09 = F 9

Filter type (dd)
01 = synthetic
02 = glas fiber
03 = compact
04 = city flo (glass fiber with carbon)
05 = city carb (compact with carbon)
22 = glass fibre, lower SFPv (e=2)

Filter lenght (e)
1 = short bag
2 = long bag
3 = short bag (vertical pockets only)
4 = long bag (vertical pockets only)
5 = compact and carbon filter (d=03,04,05)

Filter frame (f)
1 = galvanized sheet steel
2 = plastic (PP)

Prefilter for EQPB, set

EQPZ-05-bbb-c-1

Unit size (bbb)
005-090

Filter class/type (c)
2 = G2 50 mm wovlen aluminium cassette
3 = G3 50 mm syntetic/cotton, paper cassette
4 = G3 50 mm syntetic/cotton, galvanized sheet steel cassette
5 = G4 50 mm syntetic/cotton, paper cassett
6 = G4 50 mm syntetic/cotton, galvanized sheet steel cassette

Filter for eQ Top

EQPT-aaa-b-c-1

Unit size (aaa)
008, 011

Filter class (b)
5 = F5
7 = F7

Material (c)
1 = galvanized sheet steel
2 = stainless shett steel (AISI 304)

Replacement filters

Filter for EQPT

EQPZ-04-bbb-c-1

Unit size (bbb)
008, 011

Filter class (c)
5 = F5
7 = F7

Analogue differential pressure sensor

EQPZ-12-b-1

Version (b)
1 = manometer (U-tube)
2 = differential pressure sensor (Kyttelä type)
3 = differential pressure sensor (sloping tube)
4 = pressure switch manometer

Differential pressure sensor

Dwyer Magnehelic

EQPZ-25-b-c-d-1

Pressure range for first manometer (b)
1 = 0-125 Pa 2 = 0-250 Pa
3 = 0-500 Pa 4 = 0-750 Pa
5 = 0-1000 Pa

Pressure range for second manaometer (c)
0 = only one sensor
1 = 0-125 Pa 2 = 0-250 Pa
3 = 0-500 Pa 4 = 0-750 Pa
5 = 0-1000 Pa

Version (d)
1 = flush mounted in door (not EQPF)
2 = bracket mounted on panel
3 = supplied loose with bracket

Product code

Codes in green italic are included in eQ PLUS

Air heater

Air heater for hot water

EQEE-aaa-b-cc-dd-e-f-g-h-i

Unit size (aaa)

005-090

Output variant/ tube rows (b)

1, 2, 3

Material, coil (cc)

01 = Cu/Al

02 = Cu/Cu

03 = Cu/Cu tinned fins

04 = Cu/Al Corropaint

05 = Cu/Al, copper headers

Fin pitch (dd)

1 = 2 mm

2 = 2.5 mm

3 = 3 mm

Fluid circuits (ee)

From product selection tool ACON

Version (f)

1 = one complete coil

Material, frame (g)

1 = galvanized sheet steel

2 = stainless sheet steel (AISI 304)

Connection side (h)

1 = right

2 = left

Frost coil

EQEG-aaa-bb-c-d-1

Unit size (aaa)

005-090

Material, coil (bb)

00 = Cu/without fins

01 = Cu/Al

02 = Cu/Cu

03 = Cu/Cu tinned fins

04 = Cu/Al Corropaint

Material, frame (c)

1 = galvanized sheet steel

2 = stainless sheet steel (AISI 304)

Connection side (d)

1 = right

2 = left

Product code

Codes in green italic are included in eQ PLUS

*Heating coil, condensor,
for freon or water (eQ PLUS)*

EQEO-aaa-b-cc-d-e-ff-g-h-i-1

Unit size (aaa)

005-090

Media type (b)

1 = freon normal face area
2 = freon max face area
3 = water normal face area
4 = water max face area

Tube row (cc)

02, 03, 04, 06, 08, 10

Fin pitch (d)

0 = 1,8 mm
1 = 2,0 mm
2 = 2,5 mm
3 = 3,0 mm
4 = 4,0 mm
6 = 6,0 mm

Material, coil (e)

1 = Cu/Al
2 = Cu/Cu
3 = Cu/Cu tinned fins
4 = Cu/Al Corropaint
5 = Cu/Al, copper header

Fluid circuits (ff)

From product selection tool ACON

Number of output stages (g)

1 = 1 output stage (aaa = 005-108)
2 = 2 equal output stages
3 = 2 output stages (1/3 - 2/3)
4 = 3 equal output stages, split in height
5 = 4 equal output stages, split in height

Material, casing (h)

1 = galvanised sheet steel
2 = stainless sheet steel (AISI 304)

Connection side (i)

1 = right
2 = left

Gas-fired heater for natural gas (eQ PLUS)

EQEB-aaa-b-c-d-e-f-g-1

Unit size (aaa)

020-090

Output variant (b)

2, 4, 6

Controls connection (c)

0 = without
1 = with

Installation (d)

1 = standard

Gas type (e)

1 = Natural gas

Material, front panel (f)

1 = grey

Inspection side (g)

1 = right
2 = left

Air heater for steam (eQ PLUS)

EQES-aaa-b-cc-d-e-1

Unit size (aaa)

005-090

Output variant (b)

1, 2

Material, tubes/fins/headers (cc)

01 = Cu/Al/Cu (aaa = 005-045,054)
02 = Cu/Cu/Cu (aaa = 005-045,054)
03 = Fe/Al/Fe (aaa = 050)

Material, frame (d)

1 = galvanised sheet steel
2 = stainless sheet steel (AISI 304)

Connection side (e)

1 = right
2 = left

Product code

Codes in green italic are included in eQ PLUS

Air cooler

Air cooler for chilled water

EQNN-aaa-bb-c-d-ee-ff-g-h-i-j

Unit size (aaa)

005-090

Output variant (bb)

02, 03, 04, 06, 08

(bb = 08,10 for aaa = 005-090)

Version (c)

1 = normal face area

2 = full size face area (not for EQHA, EQHB)

Fin pitch (d)

1 = 2 mm

2 = 2.5 mm

3 = 3 mm

Fluid circuits (ee)

From product selection tool, ACON

Material, coil (ff)

01 = Cu/Al

02 = Cu/Cu

03 = Cu/Cu, tinned fins

04 = Cu/Al, Corropaint

05 = Cu/Al, copper headers

06 = Ti/Cu, tinned fins (aaa=081-108-216)

07 = Cu/Al, flat fins

08 = Cu/Cu, flat fins

09 = Cu/Al, copper headers and flat fins

Droplet eliminator (g)

0 = without

1 = with, plastic

2 = with, plastic withdrawable

3 = with, plastic, tropical design

4 = with, room for droplet catcher

Material, frame (h)

1 = galvanized sheet steel

2 = stainless sheet steel (AISI 304)

Connection side (i)

1 = right

2 = left

Air cooler for evaporative refrigerant

EQNP-aaa-b-c-d-e-ff-g-h-i-j-1

Unit size (aaa)

005-090

Output variant (b)

2, 3, 4, 6

Version (c)

1 = normal face area

2 = full size face area (not for EQHA, EQHB)

Coil (d)

1 = standard

Fin pitch (e)

1 = 2 mm

2 = 2.5 mm

3 = 3 mm

Material, coil (ff)

01 = Cu/Al

02 = Cu/Cu

03 = Cu/Cu, tinned fins

04 = Cu/Al, Corropaint

07 = Cu/Al, flat fins

08 = Cu/Cu, flat fins

Output stages ²⁾ (g)

1 = 1 output stage

2 = 2 equal output stages

3 = 2 output stages (1/3 + 2/3) interlace connected

4 = 3 equal output stages, split in height

5 = 4 equal output stages, split in height (2 + 2), interlace connected (aaa=009-090)

Droplet eliminator (h)

0 = without

1 = with

2 = with, plastic, withdrawable

4 = without, room for droplet eliminator

Material, frame (i)

1 = galvanized sheet steel

2 = stainless sheet steel (AISI 304)

Connection side (j)

1 = right

2 = left

²⁾ When divided coils, the output stages are for each coil.

Product code

Codes in green italic are included in eQ PLUS

Reinforced insulation on drain trough (eQ PLUS)
(for EQNN,NP)

EQNZ-01-bbb-c-1

Unit size (bbb)

005-090

Coil version (c)

1 = normal face area
2 = max. face area

Air cooler for chilled water, hygiene (eQ PLUS)

EQHN-aaa-bb-c-d-ee-ff-g-h-i-j

Unit size (aaa)

008-090

Only for EQGA, EQGB

Output variant (bb)

02, 03, 04, 06, 08, 10

Design (c)

1 = normal face area, withdrawable drain tray
2 = normal face area, non-withdrawable drain tray

Fin pitch (d)

1 = 2 mm
2 = 2.5 mm
3 = 3 mm

Fluid circuits (ee)

See product selection tool ACON

Material, coil (ff)

01 = Cu/Cu
02 = Cu/Cu, tinned fins
03 = Cu/Al, Corropaint
04 = Cu/Al
05 = Cu/Al, copper headers
06 = Cu/Al, hydropaint
07 = Cu/Al, flat fins
08 = Cu/Cu flat fins
09 = Cu/Al, copper headers and flat fins

Droplet eliminator (g)

0 = Droplet eliminator
2 = with, withdrawable
4 = without, with space for droplet eliminator

Material, frame (h)

1 = galvanized sheet steel
2 = stainless sheet steel (AISI 304)

Connection side (i)

1 = right
2 = left

Air cooler for cooling water, hygiene (eQ PLUS)

EQHP-aaa-b-c-d-ee-f-g-h-i-1

Unit size (aaa)

008-090

Only for EQGA, EQGB

Output variant (b)

2, 3, 4, 6

Design (c)

1 = normal face area, withdrawable drain tray
2 = normal face area, non-withdrawable drain tray

Fin pitch (d)

1 = 2 mm normal
2 = 2.5 mm normal
3 = 3 mm normal

Material, coil (ee)

01 = Cu/Cu
02 = Cu/Cu, tinned fins
03 = Cu/Al, Corropaint
04 = Cu/Al
05 = Cu/Al, copper headers
06 = Cu/Al, hydropaint
07 = Cu/Al, flat fins
08 = Cu/Cu flat fins
09 = Cu/Al, copper headers and flat fins

Output stages (f)

1 = 1 output stage
2 = 2 equal output stages, interlace connected

Droplet eliminator (g)

0 = without
2 = with, withdrawable
4 = with, with room for droplet eliminator

Material, frame (h)

1 = galvanized sheet steel
2 = stainless sheet steel (AISI 304)

Connection side (i)

1 = right
2 = left

Product code

Codes in green italic are included in eQ PLUS

COOLER

EQKA-aaa-b-c-dd-e-f-g-h-i-j-k

Hot gas by pass

EQKZ-01-bbb-1

Unit sizes (aaa)

008,011,018,023
032,041,050,072

Unit size (bbb)

See COOLER, EQKA.

Output variant (b)

1,2

Version (c)

1 = supply air under, counter flow
2 = supply air under, parallel flow
3 = supply air over, counter flow
4 = supply air over, parallel flow

Fin pitch (dd)

Evaporator (supply air) /
Condenser (exhaust air)
20 = 2,0 mm / 1,8 mm

Material, coil (e)

1 = Cu/Al
2 = Cu/Cu
3 = Cu/Cu *tinned fin*
4 = Cu/Al *Corropaint*

Droplet eliminator (f)

0 = without
1 = with

Water-cooled condenser (g)

0 = without
1 = with

Voltage (h)

1 = 3 x 400V, 50 Hz
2 = 3 x 230V, 50 Hz (Norway)

Control connection (i)

0 = without
1 = with

Material (j)

1 = galvanized sheet steel
2 = *stainless sheet steel (AISI 304)*

Inspection side, supply air (k)

1 = right
2 = left

Product code

Codes in green italic are included in eQ PLUS

ReCooler, cooling unit with cooling recovery (eQ PLUS)

EQKB-aaa-b-c-d-e-f-g-h-i-j-k

Unit size (aaa)
008,011,018,023
032,041,050,072

Output variant (b)
1, 2, 3, 4

Location supply air (c)
1 = tilluft under
2 = tilluft top

Material, coil (d)
1 = Cu/Al
2 = Cu/Cu
3 = Cu/Cu tinned fin
4 = Cu/Al Corropaint

Voltage (e)
1 = 3 x 400V, 50 Hz
2 = 3 x 230V, 50 Hz (Norway)

Control connection (f)
0 = without
1 = with

Droplet eliminator (g)
0 = without
1 = with

Water cooled condenser (h)
0 = without
1 = with

Material (i)
1 = galvanized sheet steel
2 = stainless sheet steel (AISI 304)

Inspection side, supply air (j)
1 = right
2 = left

Combi Cooler, cooling unit (eQ PLUS)

EQKC-aaa-b-c-d-e-f-g-h-i-1

Unit size (aaa)
014, 018, 023, 032, 041

Output variant (b)
info: compressors + evaporator
1, 2, 3

Output variant supply air coil (c)
1, 2

Design (d)
1 = supply air under, contraflow
2 = supply air under, parallel flow

Water cooled condenser (e)
0 = without
1 = with

Droplet eliminator (f)
0 = without
1 = with

Voltage (g)
1 = 3 x 400V 50Hz
2 = 3 x 230V 50Hz

Material (h)
1 = galvanized sheet steel
2 = stainless sheet steel (AISI 304)

Inspection side (i)
1 = right
2 = left

b	Comp.	Rotor
1	A	Normal
2	B	Normal
3	A	Turboterm
4	B	Turboterm

Product code

Codes in green italic are included in eQ PLUS

Humidifier, evaporative (eQ PLUS)

EQQA-aaa-b-c-d-e-1

Unit size (aaa)

009-090

Humidification rate (b)

1 = 90 % AI (not aaa=005)

2 = 60 % AI

Version (c)

1 = circulating water

2 = once-through water

Controls connection (d)

0 = with

1 = without

Inspection side (e)

1 = righthand, first floor

2 = left-hand, first floor

Humidifier, for steam lances (eQ PLUS)

Replacement for EQQA

EQQB-aaa-bbb-c-d-1

Unit size (aaa)

005-090

Length in cm (bbb)

040-180

Material (c)

1 = galvanized sheet steel

2 = stainless sheet steel (AISI 304)

Inspection side (d)

1 = right

2 = left

Humidifier fill (eQ PLUS)

Replacement for EQQA

EQQZ-01-bbb-c-1

Unit size (bbb)

008-090

Humidification rate (c)

1 = 90% AI

2 = 60% AI

Empty section adjacent to cooling coil (eQ PLUS)

EQTB-aaa-b-c-d-e-1

Unit size (aaa)

008-090

Section length, mm (b)

6 = 600

7 = 700

8 = 800

9 = 900

Position (c)

1 = upstream of EQH(N,P)

2 = downstream of EQH(N,P)

6 = upstream of EQ(NN,RF,RT)

7 = downstream of EQ(NN,RF,RT)

Material, slides for droplet eliminator (d)

1 = Galvanized steel

2 = Stainless steel (AISI 304)

Inspection side (e)

1 = right

2 = left

Dagger plate (for EQTB) (eQ PLUS)

EQTZ-05-bbb-c-1

Unit size (bbb)

008-090

Material (c)

1 = galvanized sheet steel

2 = stainless sheet steel (AISI 304)

Frost protection screen (eQ PLUS)

EQTE-aaa-b-c-1

Unit size (aa)

005-090

Material (b)

1 = galvanized sheet steel

2 = stainless sheet steel (AISI 304)

Inspection side (c)

1 = right left

2 = vänster

Product code

Codes in green italic are included in eQ PLUS

Fans

Radial fan, belt driven

EQLR-aaa-b-c-d-e-f-gg-h-i-j-1

Unit sizes (aaa)

005-090

Fan size (b)

2,3

Casing length (c)

1 = standard (short)

2 = *short*

Impeller type (d)

1 = normal impeller, backward curved

(aaa=008-090)

2 = *heavy-duty impeller, backward curved*

(aaa=008-090)

Equipment (e)

1 = standard

3 = *spark-proof design*

Position inside the casing (f)

1 = supply air

2 = exhaust air

Inlet and outlet (gg)

See figures alongside

Motor position (h)

1 = one motor, internal, rubber anti-vibration for horizontal unit (vertical aaa = 005 – 032,041)

2 = *two motors, internal, rubber anti-vibration mounting for horizontal unit (vertical aaa = 005 – 032,041)*

3 = one motor, internal, steel spring anti-vibration for horizontal unit (aaa = 008-072)

4 = *two motors, internal, steel spring anti-vibration mountings for horizontal unit (aaa=008-090)*

5 = one motor, external, incl. belt guard, rubber anti-vibration mountings for horizontal unit (aaa = 008 – 054, b = 2, 3, c=1,2) 3)

6 = *two motors, external, incl. belt guard, rubber anti-vibration mountings for horizontal unit (aaa = 008 – 054, b = 2, 3, c=1,2) 3)*

7 = one motor, outside, including belt guard, steel spring anti-vibration mountings for horizontal unit (aaa = 008 – 054, b = 2, 3, c=1,2) 3) 4)

8 = *two motors, outside, including belt guard, steel, spring anti-vibration mountings for horizontal unit (aaa = 008 – 054, b = 2, 3, c=1,2) 3)*

Material (i)

1 = galvanized sheet steel

2 = *stainless sheet steel (AISI 304) (epoxy painted casing and impeller)*

5 = *stainless sheet steel (AISI 304) (epoxy painted casing and impeller)*

Inspection side (j)

1 = right

2 = left

Normal inlet (gg)

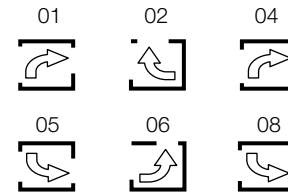

Top inlet (gg)



Product code

Codes in green italic are included in eQ PLUS

Belt drive for radial fan EQLR

EQLS-aaa-b-c-d-e-ffff-g-h-1

Unit size (aaa)

008-090

Fan size (b)

2,3

Impeller type (c)

1 = normal impeller, backward curved

2 = *heavy-duty impeller, backward curved*

Version (d)

1 = standard v-belt

2 = *standard v-belt with at least two belts*

3 = *heavy-duty v-belt*

4 = *heavy-duty v-belt with at least two belts*

7 = *flat belt drive (Habasit)*

Belt guard (e)

0 = without (aaa = 008 – 090)

1 = galvanized sheet steel screen protection for belt drive and inlet (aaa = 020–072)

2 = *galvanized sheet steel screen protection for belt drive and inlet (aaa=020-090)*

Fan speed (ffff)

r/min

Motor assembly (g)

1-8 according to EQLR

Spare set of belts (h)

0 = without

1 = with

Air distributor

EQLZ-13-bbb-c-d-1

Unit size (bbb)

008-090

Fan size (c)

2, 3

Material (d)

1 = galvanized sheet steel

2 = *stainless sheet steel (AISI 304)*

Draining (eQ PLUS)

Inspection cover for fan casing 1)

EQLZ-15-bbb-c-1

Drain connection for fan casing 2)

EQLZ-16-bbb-c-1

Unit size (bbb)

005-090

Fan size (c)

2, 3

Telpher beam (eQ PLUS)

[for motor exchange of EQLR, only for casing EQGB]

EQLZ-25-bbb-c-d-e-1

Unit size (bbb)

018-090

Fan size (c)

2, 3

Version (d)

1 = 1 motor

2 = 2 motors

Material (e)

1 = galvanized sheet steel

2 = stainless sheet steel (AISI 304)

Motor enclosures (eQ PLUS)

EQLZ-28-bbb-c-dd-e-1

Unit size (bbb)

005-090

Fan size (c)

2, 3

Motor size (IEC size) (dd)

01 = 080 10 = 180M

02 = 090S 11 = 180L

03 = 090L 12 = 200ML

04 = 100L 13 = 225SMA

05 = 112M 14 = 225SMB

06 = 132S 15 = 250SM

Material (e)

1 = galvanized sheet steel

2 = stainless sheet steel (AISI 304)

Product code

Codes in green italic are included in eQ PLUS

Telpher (eQ PLUS)

Set for EQLZ-25 sizes 068, 079-090

EQLZ-29-1

Protective screen door

EQLZ-24-bbb-c-d-1

(for EQL(R,K) internally mounted motor)

Unit size (bbb)

005-090 (005 only EQLK)

Fan size (c)

1 = Centrifugal fan (EQLR)

2 = Plenum fan (EQLK)

Material (d)

1 = galvanized sheet steel

2 = *stainless sheet steel (AISI 304)*

Analogue flow indicator for fan

(EQLK = U-tube, EQLR = Flow indicator)

EQLZ-42-bbb-c-d-1

Unit size (bbb)

005-090

Fan size (c)

2, 3

Fan type (d)

1 = Centrifugal fan (EQLK)

2 = normal impeller CENTRIMASTER (LB)

Differential thermostat

with temperature sensors (eQ PLUS)

EQRZ-03-2-1

Spacer beam (mounted) (eQ PLUS)

EQRZ-04-bbb-ccc-d

Unit size (bbb-ccc)

Bottom unit	Top unit
(same as rotor)	
bbb	ccc
020	014
027	018
036	027
068	054

Material (d)

1 = galvanised sheet steel

2 = stainless sheet steel (AISI 304)

Product code

Codes in green italic are included in eQ PLUS

Plenum fan, Centriflow Plus®

EQLK-aaa-b-c-d-e-f-g-h-i-j-k-1

Unit size (aaa)

005-090

Fan size (b)

2, 3 (aaa=005 only b=2)

Version (c)

1 = without frequency inverter fitted
 2 = with integral motor/EC-motor
 3 = with factory mounted frequency inverter (ordered separately)

Equipment (d)

1 = normal + pressure tapping
 for air flow measurement

Anti-vibration mounting (e)

1 = rubber
 2 = steel spring

Casing length (f)

From product selection tool ACON

Impeller (g)

1 = standard

Position inside the casing (h)

1 = supply air
 2 = exhaust air

Direction of air discharge (i)

1 = forward, to ducting (rectangular)
 2 = forward, to subsequent
 3 = upward (aaa=008-090)
5 = towards rear
 7 = forward, to ducting (round, size 005-009)
 8 = upward (round size 008-009)

Material (j)

1 = galvanized sheet steel
2 = stainless steel (AISI 304) (epoxypainted frame and wheel)

Inspection side (k)

1 = right
 2 = left

Product code

Codes in green italic are included in eQ PLUS

Outlet guard

EQLZ-36-bbb-c-d-1

Unit size (bbb)

005-090

Direction of air discharge (c)

2 = forward to functional section after

3 = upward

5 = toward rear

Material (d)

1 = galvanized sheet steel

2 = stainless sheet steel (AISI 304)

Contact protection inlet

EQLZ-37-bbb-c-d-e

Unit size (bbb)

005-090

Fan size (c)

2,3

Material (d)

1 = galvanized sheet steel

2 = stainless sheet steel (AISI 304)

Vibration damper (e)

1 = rubber

2 = steel springs

Cable gland

EQLZ-48-bb-c-1

Size (bb)

16 = M16	4.5 - 7.5 mm
20 = M20	9.5 - 12.0 mm
21 = M20	7.5 - 10.5 mm
25 = M25	12.5 - 15.0 mm
32 = M32	16.5 - 19.5 mm
33 = M32	14.5 - 17.5 mm
40 = M40	23.0 - 27.0 mm
41 = M40	17.0 - 21.0 mm
50 = M50	31.0 - 34.5 mm
51 = M50	25.5 - 30.0 mm
63 = M63	35.0 - 46.0 mm

Mounting (c)

1 = delivered separately

2 = assemble according to Fläkt Woods standard

Fan function for eQ Top

EQLT-aaa-b-c-d-e-1-g-h-1

Unit size (aaa)

008, 011

Fan size (b)

2,3

Design (c)

1 = Without factory mounted frequency converter

2 = Integral motor

3 = EC motor

Motor size (d)

2 = standard motor 1

3 = standard motor 2

Fan function (e)

1 = Supply air

2 = Extract air

Material (g)

1 = galvanized sheet steel

2 = stainless sheet steel (AISI 304)

Fan position (h)

1 = lower deck, right-hand

4 = upper deck, left-hand

Product code

Codes in green italic are included in eQ PLUS

Silencer, empty section

Silencer

EQSA-aaa-b-c-d-e-1

Unit size (aaa)

005-090

Length (b)

Size 005 – 090

2 = 500 mm

3 = 900 mm

4 = 1300 mm

5 = 1700 mm

Version (c)

0 = non-withdrawable baffles

1 = withdrawable baffles

Material (d)

1 = galvanized sheet steel

2 = *stainless sheet steel (AISI 304)*

Inspection side (e)

1 = right

2 = left

Empty section

EQTC-aaa-bbb-c-d-e-f-g-h-i-1

Unit size (aaa)

005-090

Length (bbb)

010-390

Opening in ceiling (c)

0 = without opening

1 = with opening for internal damper

2 = with opening for external damper

3 = opening without damper

4 = for connection of entire unit

Opening in base (d)

0 = without opening

1 = with opening for internal damper

2 = with opening for external damper

3 = opening without damper

4 = for connection of entire unit

Opening in rear side (e)

0 = without opening

1 = with opening for internal damper

2 = with opening for external damper

3 = opening without damper

4 = for connection of entire unit

Opening in inspection side (f)

0 = without opening

1 = with opening for internal damper

2 = with opening for external damper

3 = opening without damper

4 = for connection of entire unit

Drain tray (g)

0 = without

2 = *with (stainless sheet steel AISI 304)*

Inspection door (h)

0 = without

1 = with (for negative pressure)

2 = *with door (for positive pressure)*

5 = *door hung last in air direction (EQPF)*

6 = *door hung last in air direction, over pressure (EQPF)*

Inspection side (i)

1 = right

2 = left

Product code

Codes in green italic are included in eQ PLUS

Heat exchanger

Rotary heat exchanger REGOTERM®

EQRA-aaa-b-c-d-e-f-g-h-i

Horizontal airflow

Unit size (aaa)

023-054, 063, 072

Rotor execution (b)

1 = non-hygroscopic
 2 = hygroscopic
 3 = enhanced, non-hygroscopic
 4 = enhanced, hygroscopic
 5 = epoxy coated, non-hygroscopic
7 = sorption rotor
8 = edge-reinforced absorption rotor

Wave division (c)

1 = normal
2 = coarse
 5 = TURBOTERM®

Drive arrangement (d)

1 = variable speed, 1x230V
 (aaa=005,008,011,018,023)
 2 = variable speed, 1x230V
 (aaa=032,041,050,072)

Control connection (e)

0 = without
 1 = with

Length (f)

1 = standard (only rotor)
 2 = rotary with fan section before
 (for aaa = 005-032)
 3 = rotary with fan section after
 (for aaa = 005-032)
 4 = rotary with fan section before and after
 (for aaa = 005-032)

Material (g)

1 = galvanized sheet steel
2 = stainless sheet steel (AISI 304)

Supply air (h)

1 = lower floor
 2 = upper floor

Inspection side (h)

1 = right
 2 = left

Rotary heat exchanger REGOTERM®

EQRB-aaa-b-c-d-e-f-g-h-i-j-k-1

Unit size (aaa)

005-018, 056, 068, 079, 090

Rotor execution (b)

1 = non-hygroscopic
 2 = hygroscopic
 3 = non-hygroscopic, corrosion protected edges
 4 = hygroscopic, corrosion protected edges
 5 = non-hygroscopic, epoxy coated
7 = sorption rotor
8 = edge-reinforced absorption rotor

Wave division (c)

1 = normal
2 = coarse
 4 = TURBOTERM®

Power (d)

1 = 1x230 V
2 = 3x230 V
4 = 3 x 400 V, 50Hz

Drive arrangement (e)

1 = Variable speed

Control connection (f)

0 = without
 1 = with

Length (g)

1 = standard (only rotor)
 2 = rotary with fan section before
 3 = rotary with fan section after
 4 = rotary with fan section before and after
 7 = rotary heat exchanger for eQ Top with filter and fan section for supply and extract air (for aaa = 008, 011)

Supply air (h)

1 = lower floor
 2 = upper floor

Delivery configuration (i)

1 = one piece, complete delivery
2 = sectoriserad rotor, complete delivered
3 = sectoriserad rotor, split casing

Material (j)

1 = aluminium zinc coated sheet steel
2 = stainless sheet steel (AISI 304)

Inspection side (k)

1 = right
 2 = left

Product code

Codes in green italic are included in eQ PLUS

Plate heat exchanger, RECUTERM®
EQRC-aaa-b-c-d-e-f-g-h-i-1

Unit size (aaa)
005,008,011,018,023,032,041,050,072
009, 014, 020, 027, 036, 045, 047, 054, 063

Installation alternative, right-hand/left-hand (b)

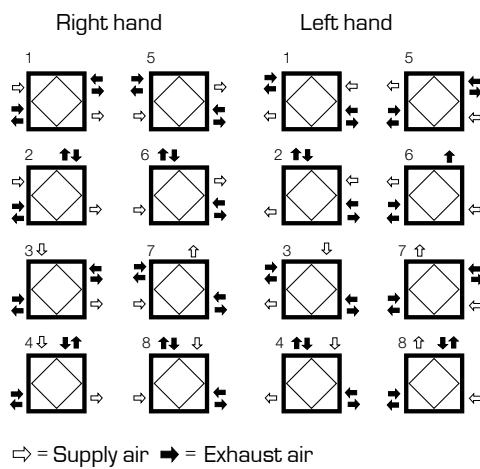

Exhaust air direction (c)
1 = upwards
2 = downward

Fine material (d)
1 = aluminium
2 = aluminium epoxy-coated

Version (e)
0 = without by-pass
1 = with by-pass damper
2 = by-pass damper with sectionalized defrosting
3 = small plate heat exchanger, by-pass damper (b = 1, 5)

Droplet eliminator, exhaust air (f)
0 = without
1 = with (for aa = 008-054,072 for exhaust air flow downwards c = 2)

Control connection (g)
0 = without
1 = with

Material (h)
1 = galvanized sheet steel
2 = stainless sheet steel (AISI 304)

Inspection side (i)
1 = right
2 = left

Drain tray
Extra tray for plate heat exchanger, Supply air side

EQRZ-01-bbb-c-d-1

Unit size (bbb)
005-054,063,072

Design, plate heat exchanger (c)
1 = large (EQRC e=0-2)
2 = small (EQRC e=3)

Material (d)
2 = stainless sheet steel (AISI 304)

Product code

Codes in green italic are included in eQ PLUS

Liquid-coupled heat exchanger ECOTERM®

EQRF-aaa-b-c-d-e-ff-gg-h-i-j-1

Unit size (aaa)

005-090

Function (b)

1 = air heater

2 = air cooler

Output variant (c)

1, 2, 3, 4 (Water circuits: 4,6,8,10)

Version (d)

1 = normal face area

2 = *max. face area*

Fin pitch (e)

1 = 2 mm

2 = *2.5 mm*

4 = 4 mm

Fluid circuits (ff)

Number of outputs, see product selection tool ACON

Material, coil (gg)

01 = Cu/Al

02 = *Cu/Cu*

03 = *Cu/Cu tinned fins*

04 = *Cu/Al Corropaint*

05 = *Cu/Al copper headers*

07 = *Cu/Al, flat fins*

08 = *Cu/Cu, flat fins*

09 = *Cu/Al, copper headers and flat fins*

Droplet eliminator (h)

0 = without

1 = with, plastic

2 = *with, withdrawable*

4 = *without, with space for droplet eliminator*

Material, frame (i)

1 = galvanized sheet steel

2 = *stainless sheet steel (AISI 304)*

Connection side (j)

1 = right

2 = left

Product code

Codes in green italic are included in eQ PLUS

Liquid-coupled heat exchanger ECONET®

EQRT-aaa-b-c-d-e-ff-gg-h-i-j-1

Unit size (aaa)

008-090

Funktion (b)

2 = Supply air, heat exchanger

3 = Exhaust air, heat exchanger

Output variant (c)

1, 2, 3, 4, 5 (Water circuits: 4,6,8,10,12)

Version (d)

1 = normal face area

2 = *max. face area*

Fin pitch (e)

1 = 2 mm

2 = 2,5 mm

4 = *4 mm*

5 = *5 mm*

Fluid circuits (ff)

From selection tool

Material, coil (gg)

01 = Cu/Al

02 = Cu/Cu

03 = Cu/Cu *tinned fins*

04 = Cu/Al *Corropaint*

05 = Cu/Al *copper header*

07 = Cu/Al, *Special Coil*

08 = Cu/Cu, *Special Coil*

09 = Cu/Al, *Special Coil, copper header*

Droplet eliminator (h)

0 = without

1 = with, plastic

2 = *with, withdrawable*

4 = *without, with space for droplet eliminator*

Material, frame (i)

1 = galvanized sheet steel

2 = *stainless sheet steel (AISI 304)*

Connection side (j)

1 = right

2 = left

Heat exchanger package for ECONET®

EQRZ-05-bbb-c-dd-eee-ff-ggg-h-1

Unit size (bbb)

008-090

Heat exchanger for (c)

1 = heating

2 = cooling

3 = heating and cooling

4 = heating, integrated in ECONET®

5 = cooling, integrated in ECONET®

6 = heating and cooling, integrated in ECONET®

Size, heat exchanger (dd)

When c=1,3.

00 when c=2

Number of plates in heat exchanger (eee)

When c=1,3.

000 when c=2

Size of cooling exchanger (ff)

When c=2,3.

00 when c=1

Number of plates in heat exchanger (ggg)

When c=2,3.

000 when c=1

Pipe (h)

1 = steel pipes for pressure vessels

2 = Stainless steel

Product code

Codes in green italic are included in eQ PLUS

Components mounted in duct

Air heater for hot water, mounted in ductwork

EQKE-aaa-bbb-c-d-e

Width in cm (aaa)

Height in cm (bbb)

(000 = circular coil)

Output variant (c)

1,2

Connection side (d)

1 = right

2 = left

EQKE

aaa	bbb	aaa	bbb
Ø 031		140	080
Ø 040		170	080
Ø 050		200	080
080	040	200	100
110	050	220	100
140	060		

*Air heater, water, mounted in ductwork
(eQ PLUS)*

EQDE-aaa-bbb-c-dd-e-ff-g-h

Width cm(aaa)

Height cm (bbb)

(000 = circular coil)

Output variant/Tube rows (c)

1, 2, 3

Material, coil (dd)

01 = Cu/Al

02 = Cu/Cu

03 = Cu/Cu tinned fins

04 = Cu/Al Corropaint

05 = Cu/Al, copper headers

Fin pitch (e)

1 = 2 mm

2 = 2,5 mm

3 = 3 mm

Fluid circuits (ff)

From product selection tool ACON

Material, frame (g)

1 = galvanised sheet steel

Electric air heater, mounted in ductwork

EQKK-aaa-bbb-c-d-e-f-g-1

Width in cm (aaa)

Height in cm (bbb)

(000 = circular coil)

Output variant (c)

1,2,3

Version (d)

1 = 3 x 230 V AC (≤ 3 kW = 2x230 V)

2 = 3 x 400 V AC (≤ 3 kW = 2x400 V)

Electrical connection (e)

1 = with thyristor and stepping switch

Control connection (f)

1 = with quick connection

EQKK

aaa	bbb
Ø 031	
Ø 040	
Ø 050	
080	040
110	050
140	060
140	080

eQ	Bredd	Höjd
Strl	aaa	bbb
005	Ø 031	-
008	Ø 040	-
011	080	040
018	110	050
023	140	060
032	140	080
041	170	080
050	200	080
072	220	100

Air cooler for chilled water, mounted in ductwork

EQKN-aaa-bbb-c-d-e-f

Width in cm (aaa)

Height in cm (bbb)

(000 = circular coil)

Output variant (c)

1,2 (always 1 when 000)

Droplet eliminator (d)

0 = without (size 005-072)

1 = with (f=1, not when bbb=000)

Connection side (e)

1 = right

2 = left

Product code

Codes in green italic are included in eQ PLUS

*Air cooler, water, mounted in ductwork
(eQ PLUS)*

EQDN-aaa-bbb-c-d-ee-ff-g-h-i-j

Width cm (aaa)

Height cm (bbb)

(000 = circular coil)

Output variant/Tube rows (c)

1, 2, 3

Material, coil (dd)

01 = Cu/Al

02 = Cu/Cu

03 = Cu/Cu tinned fins

04 = Cu/Al Corropaint

05 = Cu/Al, copper headers

Fin pitch (e)

1 = 2 mm

2 = 2,5 mm

3 = 3 mm

Fluid circuits (ff)

From product selection tool ACON

Material, frame (g)

1 = galvanised sheet steel

Connection side (i)

1 = right

2 = left

Air cooler, dx, mounted in ductwork

EQKP-aaa-bbb-c-d-e-f-1

Width in cm (aaa)

Height in cm (bbb)

(000 = circular coil)

Output variant (c)

1

Output stages (d)

1 = 1 output stage (sizes 005-011)

2 = 2 output stages 1/2+1/2 interlace

3 = 2 output stages 1/3+2/3 interlace

Droplet eliminator (e)

0 = without

1 = with

Connection side (f)

1 = right

2 = left

Sound attenuator, mounted in ductwork

EQSD-aaa-bbb-c-1

Width in cm (aaa)

Height in cm (bbb)

(000 = circular coil)

Location (b)

1 = standard

2 = eQ Top extract air and exhaust air

EQSD

aaa	bbb
Ø 031	
Ø 040* (c=2)	
Ø 040	
Ø 050	
Ø 050* (c=2)	
080	040
110	050
140	060
140	080
170	080
200	080
200	100
240	100

eQ	Bredd	Höjd
Strl	aaa	bbb
005	Ø 031	-
008	Ø 040	-
011	080	040
018	110	050
023	140	060
032	140	080
041	170	080
050	200	080
072	220	100

EQKN/EQKP

aaa	bbb
Ø 040 (EQKN)	
Ø 050 (EQKN)	
080	040
110	050
140	060
140	080
170	080
200	080
200	100
220	100

Product code

Codes in green italic are included in eQ PLUS

Accessories

Inspection window

EQAZ-01-b-1

Variant (b)

1 = standard

3 = *fire resistance rating EI30*

Adjustable feet

EQAZ-05-bbb-c-d

Unit length (bbb)

005-090

Design (c)

1 = plastic foot mounted on EQAZ-04

Lifting device

EQAZ-02-b-1

Unit size (b)

1 = for size 005-020,027, 036

2 = for size 005-072

Lifting tube, set

EQAZ-06-bbb-1

(Used together with
base frame EQAZ-04)

Base frame (eQ PLUS)

EQAZ-03-bbb-ccc-d-e-1

Unit size (bbb)

005-050

Unit size (bb)

005-090

Length (ccc)

Length, cm = (casing sub code –bbb)

Lifting spreader, set

EQAZ-07-bbb-1

Height (d)

1 = 150 mm

Unit size (bbb)

005-090

Material (e)

1 = galvanised sheet steel

2 = stainless sheet steel (AISI 304)

3 = galvanised sheet steel painted in optional colour

Water trap

EQAZ-08-b-1

Type (b)

1 = negative pressure – 800 Pa

2 = positive pressure + 3000 Pa

Base frame

EQAZ-04-bbb-ccc-d-e-f-1

Unit size (bbb)

005-090

Length (ccc)

Length, cm = block or unit length, see

Casing sub-code - bbb.

Height (d)

1 = 150 mm

2 = 300 mm (bbb=005-090, only for e=1, 2, 5)

Version (e)

1 = factory assembled, ett block

2 = factory assembled, mer än ett block

3 = *factory-mounted, one deck enhanced design
(not in combination with feet or legs)*

4 = *factory-mounted, more than one deck enhanced
design (not in combination with feet or legs)*

5 = delivered for assembly on site

6 = *delivered for assembly on site enhanced design
(not in combination with feet or legs)*

Material (f)

1 = galvanized sheet steel

2 = stainless sheet steel (AISI 304)

3 = galvanised sheet steel painted in optional RAL
colour

Product code

Codes in green italic are included in eQ PLUS

Bulkhead light

EQAZ-09-bbb-c-d-1-1

Unit size (bbb)

005-090

Type (c)

2 = LED

3 = Low energy bulb

4 = service from the outside

Delivery options (d)

1 = unassembled light

2 = connected to connection box (separate block)

3 = connected to switch (separate block)

4 = connected to common switch (entire unit)

(d=3, if the front only has inspection windows, the switcher is delivered separately)

Bulkhead light connection

EQAZ-10-b-1

Design (b)

1 = connection box

2 = switch

3 = switch connector to control panel

Location (c)

1 = Common box

2 = Switch (b=2)

3 = Switch wired to built-in control cabinet (b=1)

4 = Switch wired to built-in armature (b=1)

Tool kit for eQ casing

EQAZ-15-1

Damper

EQAZ-12-bbb-ccc-d-e-f-gg-h-i-j

Width in cm (bbb)

Height in cm (ccc)

(000 = circular damper)

Tightness class (d)

3 = CEN 3

4 = CEN 4

Connection (e)

0 = circular damper

1 = flip joint (pg)

2 = flange

Function (f)

1 = outdoor air

2 = supply air

3 = exhaust air

4 = extract air

5 = recirculated air

6 = other

Location (gg)

00 = not mounted

01 = externally end wall

02 = externally end wall, lower

03 = externally end wall, upper

04 = externally top

05 = externally base

06 = externally rear side

07 = externally inspection side

11 = internally end wall

12 = internally end wall, lower

13 = internally end wall, upper

14 = internally top

15 = internally base

16 = internally rear side

17 = internally inspection side

Damper type (h)

0 = circular damper

1 = 100 mm blade

2 = 200 mm blade

Insulation (i)

0 = without

1 = insulated blades

Material (j)

1 = galvanized sheet steel

2 = stainless sheet steel (AISI 304)

Product code

Codes in green italic are included in eQ PLUS

Lever actuator

EQAZ-13-b-c-1

Material (b)

- 1 = galvanized sheet steel
- 2 = *stainless sheet steel (AISI 304)*

Version (c)

- 1 = wheel (EQAZ-12 max bbb=150,ccc=080)
- 2 = lever

Fin comb

EQAZ-14-1

Installation kit for joining angles and two-floor units

EQAZ-16-bb-1

Material (bb)

- 01 = Sealing strip, 10m roll
- 03 = Block jointing set (jointing by baseframe)
- 10 = Seal, connector, galv. sheet steel, size 005-090
- 30 = angle brackets, galv. sheet steel, size 005-090
- 70 = Connector external kit galvanized

Material (c)

- 0 = not depended on material (bb=10)
- 1 = galvanized sheet steel
- 2 = *stainless steel sheet (AISI 304)*

Door stop (for doors on pressurized units)

EQAZ-17-1

(Not on empty section EQTC with inward opening door or width 300)

Manual air purging valve

EQAZ-18-1

Automatic air purging valve

EQAZ-19-1

Anti-slip protection (eQ PLUS)

EQAZ-20-bbb-c-1-e-1

Unit size (bbb)

(036, 045, 054- 090)

Function (c)

- 1 = Centrifugal fan (EQLR)
- 2 = Plenum fan (EQLK)
- 3 = Filter, Empty section

Material (e)

- 1 = Aluminium
- 2 = Stainless steel (AISI 304)

Expansion valve (eQ PLUS)

EQAZ-21-bb-ccc-d-1

Valve type (bb)

36,37,38 - see table

Power (ccc)

002 – 425 – see table

Delivery type (d)

- 0 = unmounted
- 1 = mounted

Refrigerant	R134a	Refrigerant	R407c	Refrigerant	R404A
36-ccc	Kw	37-ccc	Kw	38-ccc	Kw
002	1,5	002	2	002	1,5
003	3	004	4	003	2,5
006	6	009	9	006	6
009	9	013	13	008	8
014	14	019	19	012	12
017	17	024	24	016	16
024	24	033	33	022	22
032	32	044	44	029	29
037	37	052	52	034	34
045	45	062	62	043	43
053	53	075	75	051	51
066	66	094	94	063	63
076	76	111	111	072	72
102	102	149	149	095	95
128	128	191	191	122	122
179	179	234	234	167	167
230	230	319	319	217	217
280	280	425	425	272	272

Product code

Codes in green italic are included in eQ PLUS

Shrink-film packing (eQ PLUS)

EQAZ-22-bbb-ccc-d-e-1

Unit size (bbb)

(the bottom unit when double deck unit) 005-090

Length (ccc)

ccc = 030 – 990 (min. – max., in 5 cm steps)

Design (d)

1 = single unit, horizontal air flow
 2 = single unit, vertical air flow
 3 = stacked unit, horizontal air flow
 4 = stacked unit, vertical air flow

Transport (e)

2 = container

Earth cable (eQ PLUS)

EQAZ-23-bbb-c-1

Length in cm (bbb)

(standard =030)

Design (c)

1 = braided
 2 = cable

Cable area

Grounding cable: 6 mm²
 Protective conductor: 16 mm²

Espagnolette

EQAZ-24-bbb-c-d-e-1

Unit size (bbb)

Double deck casing 041,050

Unit type (c)

1 = single deck casing
 2 = double deck casing

Handle position (d)

1 = standard
 (central handle in the case of three handles)
 2 = lower (upper unit in case of two floors)
 3 = upper

Material (e)

1 = galvanized sheet steel
 2 = *stainless sheet steel (AISI 304)*

Product code

Codes in green italic are included in eQ PLUS

Flexible connection

EQAZ-25-bbb-ccc-d-e-1

Duct connection piece

EQAZ-26-bbb-ccc-d-e-1

Counter-flange (d = 2,4)

EQAZ-27-bbb-ccc-d-e-1

Protective screen

EQAZ-28-bbb-ccc-d-e-1

Floor grating

EQAZ-29-bbb-ccc-d-e-1

Adjustment panels

EQAZ-30-bbb-ccc-d-e-1

Width (bbb)

(max140 only EQAZ-30 size 005-023)

Height (ccc)

(000, round connection,
ccc max 080. EQAZ-30 only)

Connection type (d)

0 = missing (bb=29, 30 and ccc=000)
1 = PG-connection (not EQAZ-27, EQAZ-30)
2 = flange connection (not EQAZ-30)
3 = PG connection, insulated (EQAZ-25, not EQAZ-30)
4 = flange connection, insulated (EQAZ-25, not EQAZ-30)

Material (e)

1 = galvanized sheet steel
2 = stainless sheet steel (AISI 304)

Thermometer

(indicator with insertion bulb)

EQAZ-35-bbbb-c-1

Type (bbbb)

5021 = -20°C to +60°C
5022 = -20°C to +60°C / -4°F to +140°F
5023 = 0°C to +100°C

Condition on delivery (c)

0 = delivered separately

Installation instructions

EQAZ-36-bb-1

Language variant (bb)

02 = swedish
03 = english
04 = german
05 = french
06 = finnish
07 = flemish
12 = danish
20 = marine

Additional packaging (eQ PLUS)

EQAZ-39-bbb-ccc-d-1

Unit size (bbb)

005-090

Length (ccc)

Total length of casing, cm

Type of crate (d)

1 = 50% crate, truck transport
2 = 70% crate, truck transport
3 = box crate
4 = styrofoam protection on the unit
5 = 10% crate, truck transport
6 = 50% crate, container transport
7 = 70% crate, container transport

Product code

Codes in green italic are included in eQ PLUS

Flange for coils
1 connection

EQAZ-40-b-c-d-1

Connection, nr (b)

0 = 15 1 = 25
2 = 32 4 = 50
5 = 80

Type of flange (c)

(flange incl. seal and screw /nut)

1 = flange without counter-flange

(land) (b = 0-5; when b = 6 is d = 1)

2 = flange with counter-flange for thread

(land) (b = 0-5; when b = 5 is d = 2)

3 = flange with counter-flange for welding

(land) (d = 1)

*4 = mounted flange, without counter-flange (marine)
[battery/bronze]*

*5 = mounted flange with threaded counter-flange
(marine) [battery/bronze – pipe connection/steel]*

*6 = mounted flange with counter-flange for welding
(marine) [battery/bronze – pipe connection/steel]*

Material (d)

1 = steel (PN16 DIN 2633,2566)

2 = bronze (PN16 DIN 2642)

3 = steel (150Lb ANSI B16.5)

4 = bronze (150Lb ANSI B16.5)

Extension leg with adjustable feet

EQAZ-42-bbb-c-dd-e-f-1

Unit length in cm (bbb)

Variant (c)

1 = for base frame EQAZ-03 (bbb=005-090)

2 = for base frame EQAZ-04 (bbb=005-072)

Height (dd)

Nom. height (± 20 mm) incl. frame/support

25 = 25 cm

30 = 30 cm

35 = 35 cm

50 = 50 cm

Material (e)

1 = galvanized sheet steel

2 = stainless sheet steel (AISI 304)

3 = stainless sheet steel in optimal RAL colour

Version (f)

1 = stand mounted / adjustable feet supplied

(bb = 25)²⁾

2 = supplied separately

Combination cover, wall mounting

EQAZ-60-b-1

Duct connection dimensions (b)

1 = 2 x 400 mm (size 005)

2 = 2 x 500 mm (size 008,011)

Combination cover, ceiling mounting

EQAZ-61-b-1

Connection size (b)

1 = 1000 x 500 mm (size 005,008,011)

2 = 1400 x 700 mm (size 011,018)

3 = 1800 x 900 mm (size 023)

Ceiling lead-through

EQAZ-62-b-1

Connection size (b)

1 = 1000 x 500 mm (size 005,008,011)

2 = 1400 x 700 mm (size 011,018)

3 = 1800 x 900 mm (size 023)

Stand for vertical positioning

EQAZ-63-bbb-1

Unit size (bbb)

005,008

2) Only indoor single casing units

Product code

Codes in green italic are included in eQ PLUS

Roof

EQBZ-01-bbb-ccc-d-e-1

Unit size (bbb)

005-090

Length (ccc)

Length, cm = length of the multi-function block or the total length of the unit, see Casing sub-code - bbb.

Fitted to unit block (d)

- 0 = complete unit
- 1 = first multi-function block
- 2 = intermediate multi-function block
- 3 = last multi-function block
- 4 = rotary heat exchanger
- 5 = Cooler

Material (e)

- 1 = galvanized sheet steel*
- 2 = stainless sheet steel (AISI 304)*
- 3 = galvanized sheet steel, painted in optional colour*
- 5 = galvanized sheet steel coated with polyester, class M3
- 8 = aluzinc coated sheet steel

Door stops for one door
(outdoor installation)

EQBZ-03-1

Roof connection

EQBZ-04-bbb-c-1

Unit size (bbb)

005-090

Material (c)

- 1 = galvanized sheet steel*
- 2 = stainless sheet steel (AISI 304)*
- 3 = galvanized sheet steel, painted in optional colour*
- 5 = galvanized sheet steel coated with polyester, class M3
- 8 = aluzinc coated sheet steel

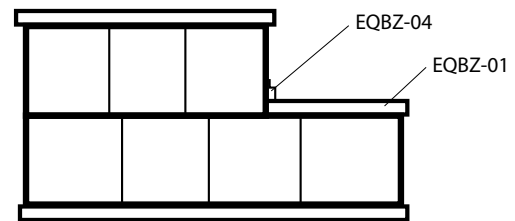

Cover, louvered shutter,
flaps for outdoor unit

EQBZ-09-bbb-ccc-d-e-f-g-1

Width (bbb)

Height (ccc)

Location (d)

- 1 = end wall
- 2 = side inlet

Variant (e)

- 1 = inlet cover
- 2 = louvered shutter (PP fins)
- 3 = flaps

Delivery form (f)

- 1 = mounted (e=2,3)
- 2 = unmounted (e=1)

Material (g)

- 2 = stainless sheet steel (AISI 304)*
- 3 = galvanized sheet steel, painted in optional colour*
- 8 = aluzinc coated sheet steel

Product code

Codes in green italic are included in eQ PLUS

Cowl for inlet and outlet in end wall

EQBZ-10-bbb-c-d-e-f-g-1

Unit size (bbb)

005-090 (005 only EQLK)

For function (c)

1 = EQVA

2 = EQLK

3 = EQLR

Version(d)

1 = cowl with outlet side wall

2 = cowl with outlet/inlet in front

Safety net (e)

0 = without

1 = with

Delivery type (f)

1 = mounted(d = 1)

2 = not mounted (d = 2)

Material (g)

2 = stainless steel (AISI 304)

3 = galvanised and painted in optional colour

8 = aluzinc coated sheet steel

Cowl for inlet and outlet in side wall

EQBZ-11-bbb-ccc-d-e-1

Width (bbb)

Height (ccc)

Delivery type (d)

2 = unmounted

Material (e)

2 = stainless sheet steel (AISI 304)

3 = galvanised and painted in optional colour

8 = aluminium sheet steel

Bottom drain

(ordered together with base frame EQAZ-03 or EQAZ-04)

EQWZ-01-bbb-1

Unit size (bbb)

005-090

Drain trough

(not for TB2 casing)

EQWZ-02-bbb-1

Length (bbb)

Length, cm = block length³⁾

(see code for casing – sub code bbb)

³⁾ Drain trough only under doors.

Product code

Codes in green italic are included in eQ PLUS

Motors

Single-speed motor

APAL-a-bbbbbb-c-d-e

Number of poles (a)

2,4,6,8

Rated output (bbbbbb)

Rated output to be specified in kW x 100

e.g. bbbbbb = 00175 denotes 1.75kW

Voltage (c)

1 = 220-230 V

2 = 380-400 V

4 = 400-415 V

5 = 500 V

Temperature sensors in stator winding (d)

0 = without

1 = with thermostatic contacts

2 = with thermistor

Motor (e)

0 = IE1 efficiency class 2 ABB

1 = IE2 efficiency class 1 ABB

2 = IE1 efficiency class 2 WEG

6 = IE1 efficiency class Fläkt Woods standard

Integral motor

APAT-a-bbbbbb-30-20

Number of poles (a)

2,4

Rated output (bbbbbb)

Rated output to be specified in kW x 100

eg. bbbbbb = 00037 denotes 0.37 kW

Motor, EC

APEC-2-bbbbbb-c-2-1

Rated output (bbbbbb)

bbbbbb = size of motor in combination

with fan 01, 02, 03

bbbbbb = rated output to be specified in

kW x 100 eg. bbbbbb = 037 denotes 0.37 kW

Voltage (c)

1 = 1 x 230 V

3 = 3 x 400 V

Two-speed motor, 4/6 poles, with separate stator windings

ATAL-a-bbbbbb-c-d

Two-speed motor, 4/6 poles, with separate windings, highest output for both speeds

ATSL-a-bbbbbb-c-d

Two-speed motor, 2/4, 4/8 poles, Dahlander-winding

ARAL-a-bbbbbb-c-d

Two-speed motor, 2/4, 4/8 poles, separate windings, highest output for both speeds

ARSL-a-bbbbbb-c-d

Two-speed motor, 2/4, 4/8 poles, with separate stator windings

ASSL-a-bbbbbb-c-d

Number of poles (a)

2,4,6,8

Rated output (bbbbbb)

Rated output to be specified in kW x 100

e.g. bbbbbb = 00175 denotes 1.75kW

Voltage (c)

1 = 220-230 V

2 = 380-400 V

4 = 400-415 V

5 = 500 V

Temperature sensors in stator winding (d)

0 = without

1 = with thermostatic contacts

2 = with thermistor

Product code

Codes in green italic are included in eQ PLUS

Control equipment

Cable trunking

EQAZ-53-bbb-ccc-d-e-1

Unit size (bbb)

005-090

Length (dm) (ccc)

010 = 10dm

020 = 20dm

350 = 350dm

999 = 999dm

Number of vertical trunkings (d)

0 = Without

1 = 1

2 = 2

etc.

Material (e)

2=Stainless sheet steel (AISI 304)

5=Plastic (PVC)

6=Natural anodized aluminium

Electrical equipment cubicle section

EQEL-aaa-bb-ccc-d-e-f-g-h-i-1

Unit size (aaa)

008-090

Function (bb)

01 = single-level electric cubicle section for STEQ

02 = two-level electric cubicle section for STEQ

Power supply to frequency inverter (ccc)

Specified in kW with one decimal

Ex, 5.5kW = 055

Supply voltage (d)

0 = without built-in frequency inverter

2 = 3 x 400 VAC

Make of control unit (e)

0 = without

2 = Siemens Climatix

Version (f)

1 = indoor

2 = outdoor

Flange location (g)

0 = without flange

1 = in ceiling

2 = lower front

3 = upper front

Material (h)

1 = galvanized sheet steel

2 = stainless steel (AISI 304)

Inspection side (i)

1 = right-hand

2 = left-hand

Product code

Codes in green italic are included in eQ PLUS

Empty section for controls

EQTK-aaa-bbb-c-d-1

Unit size (aaa)

005 – 072

079-090

Length (bbb)

010 - 390

Function (c)

1 = for control cabinet ControlMaster

Inspection side (d)

1 = right

2 = left

Control equipment

STEQ-aaa-bb-cc-d-e-f-gg-h-i-j

Air heater (aaa)

000 = without reheating

002 = Econet, external heat

003 = heating water, external pipework package

004 = electric, in air heater built-in thyristor

005-280 = electrical heater for binary coupling or thyristor 5-250kW

500 = Gasburner, EQEB

600 = Combi coil (heater/cooler)

Heat exchanger (bb)

00 = without heat exchanger

10 = rotary heat exchanger

12 = Rotating heat exchanger, with indirect evaporative cooling

20 = plate heat exchanger

30 = liquid-coupled heat exchanger (ECOTERM®)

32 = ECONET®

Cooling (cc)

00 = no cooling

10 = chilled water

20 = evaporative refrigerant, 1 step

21 = evaporative refrigerant, 2 steps

22 = evaporative refrigerant, 2 steps, binary coupled

23 = evaporating refrigerant, 3 step

24 = evaporating refrigerant, 4 step

30 = cooling unit, EQKA / EQKR

40 = ECONET®, external cooling

60 = combi coil (Heater/cooler)

70 = Combi Cooler

Mixing (d)

0 = without

1 = with, operation at night only

2 = with, in control sequence

3 = with, for CO2 control

Location (e)

1 = in cabinet

2 = in electrical cabinet

3 = in fixed panel

4 = in the ceiling

5 = in an empty section (EQEL)

Voltage (f)

1 = 1x230 VAC

2 = 3x230 VAC

4 = 3x400 VAC

Control unit (gg)

00 = without

65 = Siemens Climatix 600, TCP/IP + exp

HMI (display) (h)

0 = without display / standard display

5 = Alfanumerical, IP30

6 = Semigrafical, handheld

7 = Semigrafical, panel mounted

Version (i)

1 = standard

2 = outdoor

Design (j)

1 = ControlMaster

2 = ControlMaster PLUS

Product code

Codes in green italic are included in eQ PLUS

Temperature control

STAZ-01-b-c-d-e-f-g-h-i-jj-1

Type of control (b)

- 1 = supply air control
- 2 = extract air control
- 3 = room control
- 4 = room control, average value, 4 sensors*
- 6 = changeover:
- Winter = supply air control
- Summer = exhaust air control

Night-time cooling (c)

- 0 = without
- 1 = with free cooling

Night-time heating (d)

- 0 = without
- 1 = with
- 2 = with, 100% return air, exhaust air fan in op,
- 3 = with, 100% return air, exhaust air fan stopped

Cooling energy recovery (e)

- 0 = without
- 1 = with

Set point displacement (f)

- 0 = without
- 1 = outdoor compensated temp. set point

Flow compensation (g)

- 0 = without
- 1 = blocking high speed at low outdoor temp
- 2 = Outdoor temp. compensated flow via curve
- 4 = Outdoor temp. compensated pressure set point

Efficiency measurement (h)

- 0 = without
- 1 = extract air measurement
- 2 = supply air measurement

Type of sensor (i)

- 1 = standard
- 2 = Ni1000LG*
- 5 = PT 1000*

Control unit (jj)

- 65 = Siemens Climatix 600, TCP/IP + exp

Temperature sensor

STAZ-02-bb-c-d-e

Type of sensor (bb)

- 10 = supply air temp. sensor
- 20 = extract air temp. sensor
- 30 = outdoor air sensor
- 40 = efficiency sensor, supply air
- 50 = exhaust air sensor
- 60 = frostcoil sensor, off-coil temp.
- 70 = room sensor
- 80 = supply water temperature*

Sensor element (c)

- 1 = standard
- 2 = Ni 1000LG*
- 5 = PT 1000*

Version (d)

- 1 = sensor fitted to air handling unit
- 2 = duct sensor
- 3 = wall-mounted sensor

Delivery configuration (e)

- 1 = mounted on current sub*
- 2 = fit to relevant item, quick-fit connector
- 3 = delivered with relevant item
- 5 = delivered with STEQ
- 7 = delivered with STEQ, quick-fit connector

Product code

Codes in green italic are included in eQ PLUS

Preheater (Frostcoil)

STAZ-08-bbb-c-d-e

Type of air heater (bbb)

003 = heating water, external pipework package

004 = electric, in air heater built-in thyristor

005-280 = electrical heater for binary coupling or thyristor 5-250kW

Version (c)

1 = standard

2 = control module

Make (d)

1 = standard

6 = Siemens

Delivery configuration (e)

1 = mounted on current sub

2 = fit to relevant item, quick-fit connector

4 = fitted to STEQ

Zone control

STAZ-09-b-c-ddd-e-f-g-h

Location (b)

1 = zone 1

2 = zone 2

3 = zone 3

4 = zone 4

Type of control (c)

1 = supply air control

2 = exhaust air control

3 = room control

6 = Su/Wi Room/Supply air control

Air heater (ddd)

000 = without

003 = water, external shunt

004 = electrical, built in thyristor

Cooling (e)

0 = no cooling

1 = cooled water

2 = evaporative refrigerant, 1 step

3 = evaporative refrigerant, 2 steps

4 = evaporative refrigerant, 2 steps, binary coupled

External setpoint (f)

0 = none, setpoint from main controller

1 = offset

2 = overriding

Design (g)

1 = standard

Delivery options (h)

1 = Mounted on current sub

4 = Mounted on STEQ

Product code

Codes in green italic are included in eQ PLUS

Defrosting

STAZ-10-b-c-d-e

Location (b)

- 1 = rotary heat exchanger
- 2 = plate heat exchanger
- 3 = liquid-coupled heat exchanger

Defrosting method (c)

- 1 = pressure switch
- 2 = cold corner
- 3 = section-by-section defrosting
- 4 = temp. sensor

Type of sensor (d)

- 0 = without
- 1 = standard
- 2 = *Ni1000LG, Siemens*
- 4 = *PT1000*
- 9 = pressure switch

Delivery configuration (e)

- 2 = fitted on relevant item, quick-fit connector

Anti-freeze sensor

STAZ-11-b-c-d-e

Location (bb)

- 10 = air heater*
- 50 = frost coil

*) Second digit indicates location:

- 0 = eQ
- 1...4 only *

Type of sensor (c)

- 0 = thermostat
- 1 = standard
- 2 = *Ni1000LG, Siemens*
- 4 = *PT1000*

Version (d)

- 1 = insertion sensor
- 2 = strap-on sensor
- 3 = *Capillar tub thermostat*

Delivery configuration (e)

- 1 = *mounted on current sub*
- 2 = fitted to relevant item, quick-fit connector
- 3 = delivered with relevant item
- 5 = delivered with STEQ
- 7 = delivered with STEQ, quick-fit connector

Starting equipment, pump (for circulation pump)

STAZ-15-bb-c-d-eee-f-g

Location (b)

- 10 = air heater*
- 20 = air cooler*
- 40 = energy recovery
- 50 = pre-heater

*) Second digit indicates location:

- 0 = eQ
- 1...4 only *

Starting method (c)

- 1 = direct on-line starting

Voltage (d)

- 1 = 1 x 230 VAC
- 2 = 3 x 230 VAC
- 4 = 3 x 400 VAC

Rated current, (eee)

To be specified with two decimals
ex 0,23 A write bbb = 023

Motor protection (f)

- 0 = without (d=1, eee=0-500)
- 1 = standard
- 2 = *temperature contact*
- 3 = *thermistor*

Delivery configuration (g)

- 4 = fitted to STEQ
- 5 = delivered with STEQ
- 6 = delivered with relevant item

* max. 1 STAZ-15 with f=1

Product code

Codes in green italic are included in eQ PLUS

Valve / Valve actuator

STAZ-16-bb-c-d-ee-fff-g

Brand (bb)

60 = Siemens

Control option (c)

1 = actuator
2 = valve+actuator
3 = valve

Type of valve (d)

0 = without
2 = 2-way
3 = 3-way

Location (ee)

10 = air heater
20 = air cooler
40 = energy recovery
50 = pre-heater

*) Second digit indicates location:

0 = eQ
1...4 only *

kvs-value (fff)

000 = without
002 = 0.25
025 = 2.5
250 = 25
etc.

Delivery configuration (g)

3 = delivered with relevant item
5 = delivered with STEQ
6 = delivered with own item
7 = delivered with STEQ, quick-fit connector

Kvs-value	Siemens-actuator/valve	t.a.c-actuator
0.25-2.5	SGS65/WVG44	M310
4.0-6.3	SGS65/WVG44	M400
10-40	SQX62/WVG41	M400
49	SKB62/WVF31	
63	SKB62/WVF31	M800
78	SKB62/WVF31	M800
63-99.9	SKC62/WVF31	M800

Pipework package

STAZ-17-bb-cc-ddd-e-f-g-h-ii-j

Brand (bb)

60 = Siemens

Connection (cc)

15 = DN15 20 = DN20
25 = DN25 32 = DN32
50 = DN50 65 = DN65

Kvs value(ddd)

004 = 0.4 006 = 0.63
010 = 1.0 016 = 1.6
025 = 2.5 040 = 4.0
063 = 6.3 100 = 10
160 = 16 250 = 25
400 = 40 630 = 63

Type of valve (e)

2 = 2-way
3 = 3-way

Insulation (f)

0=without
1=heating
2=cooling (moisture barrier insulation)

Installation alternative (g)

1=right-hand
2=left-hand

Voltage (h)

1=1-phase 230V
2=3-phase 230V
4=3-phase 400V

Variant (i)

1-4

Delivery configuration (h)

3 = delivered with relevant item
5 = delivered with STEQ
6 = delivered with own item

Product code

Codes in green italic are included in eQ PLUS

Fan control

STAZ-20-b-c-d-e-f-g-1-i

Location (b)

- 1 = supply air fan
- 2 = extract air fan
- 3 = double supply fans*
- 4 = double exhaust fans*

Control function (c)

- 0 = without
- 1 = constant speed via frequency converter*
- 2 = two speed via frequency converter*
- 3 = pressure control*
- 4 = flow control
- 5 = CO₂-compensation, duct sensor
- 6 = CO₂-compensation, room sensor
- 7 = slave-controlled flow
- 9 = pressure controlled with flow readings

Control reference (d)

- 0 = set point in computer substation
- 1 = supply air fan
- 2 = extract air fan
- 3 = double supply fans*
- 4 = double exhaust fans*
- 5 = external fan

Pressure range (e)

- 0 = without
- 1 = 0-500 Pa
- 2 = 0-1000 Pa
- 3 = 0-3000 Pa
- 5 = 0-5000 Pa
- 7 = 0-7000 Pa

Fire function (f)

- 0 = without
- 1 = supply air fan in operation
- 2 = extract air fan in operation
- 3 = supply air fan and exhaust air fan in operation

Version (g)

- 1 = standard
- 2 = ModBus (b=5)

Design (h)

- 1 = eQ

Delivery configuration (i)

- 1 = mounted on current sub*
- 2 = fitted to relevant item, Quick-fit connector
- 3 = delivered with relevant item
- 5 = delivered with STEQ

Starting equipment - fan

STAZ-21-b-c-d-e-fff-ggg-h-i

Location (b)

- 1 = supply air 1
- 2 = extract air 1
- 3 = supply 2*
- 4 = exhaust 2*

Motor (c)

- 1 = single speed
- 2 = 2-Speed
- 3 = 2-Speed Dahlander*

Starting method (d)

- 1 = direct start*
- 2 = Y/D start*
- 3 = frequency inverter
- 4 = integral motor
- 5 = EC motor

Voltage (e)

- 1 = 230 VAC, 1-phase
- 2 = 230 VAC, 3-phase
- 4 = 400 VAC, 3-phase

Rated current, high speed (fff)

Example: ATAL-4-00240-4-0 consumes 6,3 A operating in high speed mode according to table
Write fff = 063

Rated current, low speed (ggg)

Example: ATAL-4-00240-4-0 consumes 3,1 A operating in low speed mode according to table,
Write fff = 031
For one-speed motor, write ggg = 000.

Motor protection (h)

- 0 = without
- 1 = temperature contact*
- 2 = thermistor*
- 2 = thermistor
- 3 = standard

Delivery configuration (i)

- 1 = fitted to relevant item
- 2 = fitted to relevant item, Quick-fit connector
- 4 = fitted on STEQ
- 5 = delivered with STEQ
- 6 = supplied on separate sub*

Product code

Codes in green italic are included in eQ PLUS

Pressure/flow indicator

STAZ-22-b-c-d-e-f

Location (b)

- 1 = supply air fan
- 2 = extract air fan
- 3 = double supply fans*
- 4 = double exhaust fans*
- 5 = exhaust air fan

Type (c)

- 1 = pressure linear
- 2 = flow linear
- 3 = pressure/flow linear

Pressure area (d)

- 1 = 0-500 Pa
- 2 = 0-1000 Pa
- 3 = 0-3000 Pa
- 5 = 0-5000 Pa
- 7 = 0-7000 Pa

Display (e)

- 0 = without
- 1 = with

Delivery configuration (f)

- 1 = fitted on relevant item
- 2 = monterar on relevant item, quick-fit connector
- 3 = delivered with relevant item
- 5 = delivered with STEQ
- 7 = delivered with STEQ, quick-fit connector

Flow monitor

STAZ-23-b-c

Location (b)

- 1 = supply air fan
- 2 = extract air fan
- 3 = double supply fans*
- 4 = double exhaust fans*
- 5 = external fan

Delivery configuration (c)

- 1 = fitted on relevant item
- 2 = to be to be mounted on relevant item, quick-fit connector
- 3 = delivered with relevant item
- 5 = delivered with STEQ

Filter monitor

STAZ-24-b-c

Location (b)

- 1 = supply air
- 2 = extract air
- 3 = supply air incl. pre-filter
- 4 = extract air incl. pre-filter
- 5 = supply air, separate alarm
- 6 = extract air, separate alarm
- 7 = supply air incl. pre-filter, separate alarm
- 8 = extract air incl. pre-filter, separate alarm

Delivery configuration (c)

- 1 = mounted on current sub*
- 2 = to be to be mounted on relevant item, quick-fit connector
- 3 = supplied with current sub*
- 5 = supplied with STEQ*
- 7 = delivered with STEQ, quick-fit connector

Product code

Codes in green italic are included in eQ PLUS

Control of external fan

STAZ-25-b-c-d-e-f-g-h-i

Location (b)

- 1 = External fan 1
- 2 = External fan 2
- 3 = External fan 3
- 4 = External fan 4

Motor/Control functions (cc)

- 01 = direct on-line starting, single speed motor
- 02 = Two-speed
- 03 = Two-speed, Dahlander
- 04 = Single speed, Y/D-start
- 11 = Constant speed via frequency inverter
- 12 = Two-speed via frequency inverter
- 13 = Pressure control
- 14 = Flow control
- 15 = *CO₂ compensation, duct sensor*
- 16 = *CO₂ compensation, room sensor*
- 17 = *slave flow control*
- 18 = *pressure control with flow display*

Pressure range (d)

- 0 = without
- 1 = 0-500 Pa
- 2 = 0-1000 Pa
- 3 = 0-3000 Pa
- 5 = 0-5000 Pa
- 7 = 0-7000 Pa

Control (e)

- 1 = Parallel to the Air Handling Unit
- 2 = Parallel only one step
- 3 = *Internal time channel*
- 4 = External switch

Voltage (f)

- 1 = 230 VAC, 1-fas
- 2 = 230 VAC, 3-fas
- 4 = 400 VAC, 3-fas

Current, high speed (ggg)

Exempel ATAL-4-00240-4-0 consumes at high speed according to table 6.3 A. Write ggg = 063

Current, low speed (hhh)

Exempel ATAL-4-00240-4-0 consumes at low speed according to table 3.1 A. Write hhh = 031
At single speedmotor, write hhh = 000.

Motor protection (i)

- 0 = without
- 1 = thermo contact
- 2 = thermistor

Delivery options (i)

- 1 = mounted on current sub
- 2 = *mounted on STEQ*

Product code

Codes in green italic are included in eQ PLUS

Damper actuator

STAZ-30-b-cc-d-e-f-g-h

Location (b)

- 1 = outdoor air damper
- 2 = extract air damper
- 3 = recirculated air
- 4 = plate heat exchanger
- 8 = exhaust air damper
- 9 = mixing damper

Required torque [Nm] (cc)

Example:

- 7.3 Nm = 08
- 14.7 Nm = 15

Type (d)

- 1 = two-position
- 2 = two-position with spring
- 5 = modulating (0,,,10VDC)
- 6 = Modulating with spring return (0..10VDC)
- 9 = Customer supplied*

End position contacts (e)

- 0 = Without
- 1 = With*

Supply voltage (f)

- 2 = 24VAC
- 3 = 230VAC*

Quantity (g)

- 0-9 = quantity

Delivery configuration (h)

- 1 = fitted on relevant item
- 2 = to be to be mounted on relevant item, quick-fit connector
- 3 = delivered with relevant item
- 5 = delivered with STEQ

Damper actuator, additional zone

STAZ-31-b-cc-d-e

Location (b)

- 1 = supply air
- 2 = extract air
- 3 = supply- and extract air

Type os actuator (cc)

- 1 = 2-Point, 8 Nm, 24VAC*
- 2 = 2-Point, 8 Nm, 230VAC
- 11 = 2-Point, 18 Nm, 24VAC*
- 12 = 2-Point, 18 Nm, 230VAC
- 21 = 2-Point, 30 Nm, 24VAC*
- 22 = 2-Point, 30 Nm, 230VAC
- 31 = 2-Point with spring return, 15 Nm, 24VAC*
- 32 = 2-Point with spring return, 15 Nm, 230VAC
- 41 = 2-Point with spring return, 20 Nm, 24VAC*
- 42 = 2-Point with spring return, 20 Nm, 230VAC
- 90 = Customer supplied*

Controlled by (d)

- 1 = timer
- 2 = push button
- 3 = CO₂-monitor
- 4 = motion detector
- 5 = parallel with AHU*
- 6 = separate time schedule*

Delivery configuration (e)

- 5 = delivered with STEQ

Product code

Codes in green italic are included in eQ PLUS

Control documentation

STAZ-36-bb-c-ddd-e-f-g-h

Control unit (bb)

00 = without control equipment
65 = Siemens Climatix 600, TCP/IP + exp

Unit family (c)

1 = ControlMaster
2 = ControlMaster PLUS

Unit size (ddd)

005 – 072
079-090

Delivery version (e)

0 = without control
1 = with control in built-in cubicle
2 = with controls, wall mounted cabinet

Language on documentation, wiring diagram (f)

1 = swedish
2 = german
3 = english
4 = finnish
5 = danish
7 = french

Language on computer substation display (g)

00 = without
01 = swedish
02 = german
03 = english
04 = finnish
05 = danish
06 = islandic
07 = french
08 = latvian
09 = lithuanian
10 = czech
11 = russian

Wiring diagrams / name plate designations (h)

1 = Fläkt Woods standard version
2 = Object defined

Fire function

STAZ-40-b

Control unit (b)

1 = alarm from external fire alarm (potential-free contact)
2 = max 4 smoke detectors, (no damper control)
6 = max 2 smoke detectors, exercise of max 2 dampers
7 = max 4 smoke detectors, exercise of max 4 dampers
8 = max 6 smoke detectors, exercise of max 6 dampers
9 = max 8 smoke detectors, exercise of max 8 dampers

FICO / STEZ-40

b = 1 alarm function
b = 2 controller for smoke detectors, Calectro
b = 6 central unit FCM-1
b = 7 central unit SOC6.00-1 + 2 connection boxes
b = 8 central unit SOC6.00-2 + 3 connection boxes
b = 9 central unit SOC6.00-2 + 4 connection boxes

Extra transformer for fire equipment
(Enables more smoke detectors per exercise unit, used together with STAZ-40 when more than 8 damper actuators are used)

STAZ-41-b

Output (b)

5 = 240 VA

Product code

Codes in green italic are included in eQ PLUS

Smoke detectors

(Ionising, used together with STAZ-40)

STAZ-42-b-c-d-ee

Type (b)

1 = ionising
2 = optical

Supply air (c)

0-8 = quantity

Extract air (d)

0-8 = quantity

Mounting shelf (ee)

00-16 = quantity

Smoke damper function

Incl. 2-position spring return damper actuator,
24 VAC (Is not used during fire damper exercise)

STAZ-43-b-c-d-e

Supply air (b)

0-9 = quantity (closing)

Extract air (c)

0-9 = quantity (closing)

Supply air extraction (d)

0-1 = quantity (opening)

Extract air extraction (e)

0-1 = quantity (opening)

Fire thermostat

STAZ-44-b-c

Supply air (b)

0-1 = quantity

Extract air (c)

0-1 = quantity

Prolonged/boosted operation

STAZ-50-b-c-d-e-f

Boosted operation (b)

1 = prolonged operation
2 = boosted flow
3 = boosted flow, prolonged operation

Control via external timer (c)

0-5 st

Control via external pushbutton (d)

0-5 st

Control via CO₂-vakt (e)

0-5 st

Control via motion detector (f)

0-5 st

Communication

STAZ-51-bb-c-d-e

Control unit (bb)

65 = Siemens Climatix 600, TCP/IP + exp

Web (c)

0 = without
1 = simple web application
2 = web appl, with images
3 = *separate web*

Alarm via SMS (d)

0 = without
1 = with GSM modem

Protocol (e)

0 = standard
1 = LonWorks
2 = Modbus RTU
3 = BACnet IP
5 = OPC Server

Product code

Codes in green italic are included in eQ PLUS

Multipole cable

STAZ-70-b-ccc-d-e-fff-g

Multi cable box (b)

- 1 = standard
- 2 = heat exchanger
- 3 = heat pump/Cooler

Multi cable length (ccc)

(Function of Unit size)
100 – 999 length in cm

Connection accessory (d)

- 0 = without
- 1 = power supply to light fittings

Location, Cable duct (e)

- 1 = intern
- 2 = external, upper
- 3 = external, lower

Current (fff)

Current in A with one decimal x10
0046 = 4,6A

Version (g)

- 1 = 1-1
- 2 = 1-2
- 3 = 1-3

Control unit Twin Wheel (eQ PLUS)

STAZ-72-bbb-c-d-e-f-g-h

Unit size (bbb)

008-090

Supply air floor (c)

- 1 = bottom
- 2 = top

Inspection side (d)

- 1 = right
- 2 = left

Design (e)

- 1 = indoor
- 2 = outdoor

Voltage (f)

- 2 = 3x230 VAC
- 4 = 3x400 VAC

Communication (g)

- 0 = Standard
- 1 = LonWorks
- 2 = Modbus RTU
- 3 = BACnet IP
- 5 = OPC Server

Version (h)

- 1 = Standard

Product code

Codes in green italic are included in eQ PLUS

ECONET® Pump unit

STAZ-74-bbb-c-d-e-f-g-h-i-j-k-4

Unit size (bbb)

005-090

Pump choice (c)

1 = single pump
2 = double pump

Efficiency calculation (d)

0 = without
1 = energy calculation
2 = efficiency and energy calculation

Communication (e)

0 = without
3 = LONWORKS
7 = Modbus RTU
8 = BACnet
9 = web pages

Electrical connection (f)

6 = Plug & Play
7 = standard

Power supply, protection class (g)

1 = 3 x 400 VAC, IP21
2 = 3 x 400 VAC, IP54

Bracket/stand (h)

1 = standard
2 = integrated energy exchanger package

Language (i)

1 = swedish
2 = german
3 = english
4 = finnish

Material (j)

1 = standard
2 = stainless steel

Construction variant (k)

4 = ECONET® ver. 4

External Auxilliary functions

STAZ-75-b-c-0-0-f-gg-h-i-j

Temperature zones (b)

0 - 4 = amount

External fans (c)

0 - 4 = amount

Voltage (f)

1 = 1x230 VAC
3 = 3x230 VAC
4 = 3x400 VAC

Control equipment (gg)

00 = Without
60 = Siemens

HMI (display) (h)

0 = Without display / standard display
5 = Alfanumerisk med inställningsratt, IP30
6 = Semigrafical, IP55

Design (i)

1 = standard
2 = Outdoor

Construction (j)

1 = eQ

Product code

Codes in green italic are included in eQ PLUS

Switch disconnecter

STAZ-80-bbb-c-d

Max current (bbb)

016 = 16 Ampere
045 = 45 Ampere
Etc.

Voltage (c)

2 = 3x230 VAC
4 = 3x400 VAC

Accessories (d)

0 = without
1 = with auxiliary switches (1 NC, 1 NO)
2 = with auxiliary switches (1 NC, 1 NO) and service voltage

Delivery options (e)

5 = delivered with STEQ

Energy measurement

STAZ-81-b-ccc-d-e

Scope (b)

1 = total energy consumption
2 = Fan power
3 = Electrical heater
4 = Cooler
5 = Heat pump

Max current (ccc)

016 = 16 Ampere
045 = 45 Ampere

Measuring signal (d)

1 = standard
2 = Modbus RTU
3 = Pulse signal

Delivery configuration (e)

1 = mounted on current sub
3 = delivered with relevant item
4 = fitted on STEQ
5 = delivered with STEQ

Transformer

STAZ-82-b-cc-d

Voltage (b)

1 = 230 till 400 V AC

Output (cc)

12 = 12.5 kVA
16 = 16 kVA
20 = 20 kVA
25 = 25 kVA
40 = 40 kVA

Version (d)

1 = full

Extra fuse (eQ PLUS)

STAZ-83-bbb-c-d-e

Current (bbb)

010 = 10 A
016 = 16 A
020 = 20 A

Phase (c)

1 = 1-phase
3 = 3-phase

Intended for (d)

1 = COOLER
2 = DX-cooler
3 = AHU lightning, before main disconnecter
4 = Other

Delivery options (e)

1 = Built in AHU, bbb < 25 A
4 = Wall mounted cabinet, bbb < 125 A
5 = Wall mounted cabinet, on AHU, bbb < 63 A

Lightning / power socket in electrical cabinet (eQ PLUS)

[Incl. automatic personal protection, before main disconnecter]

STAZ-84-b-c

Type (b)

1 = 230 VAC socket
2 = Tube light with 230 VAC socket
3 = Tube light with 230 VAC socket with magnets

Country standard (c)

1 = Sweden

Product code

Codes in green italic are included in eQ PLUS

Frequency inverter

STRR-a-b-cccc-d-e-f-g-hh-i

Location (a)

- 1 = supply air 1
- 2 = extract air 1
- 3 = *supply fan 2*
- 4 = *exhaust fan 2*
- 5 = external
- 6 = *circulating pump*

Net voltage (b)

- 2 = 3x230 V AC
- 4 = 3x400 V AC

Current (cccc)

- Current in A with one decimal x 10
- 0046 = 4.6 A
- 0200 = 20 A
- etc

Phase (d)

- 1 = 1-phase
- 3 = 3-phase

Filter (e)

- 0 = without
- 1 = RFI-filter

Degree of protection (f)

- 1 = IP21
- 2 = IP54

Version (g)

- 0 = without
- 1 = on panel
- 2 = *built in cabinet*
- 3 = *in electrical cabinet*
- 4 = *on bracket*
- 9 = on motor

Make, type (hh)

- 00 = FWG, standard
- 13 = *ABB, ACH550*
- 30 = *Danfoss, FC100*
- 31 = *Danfoss, FCM300*
- 40 = *Grundfoss MGE*
- 50 = *Ebm-Papst*

Delivery configuration (i)

- 1 = fitted on relevant item
- 2 = to be to be mounted on relevant item, quick-fit connector
- 3 = delivered with relevant item
- 5 = delivered with STEQ
- 6 = delivered with own item

Motor accessories

APAC-a-b-c-d-e-ffff-ggg-h-i-0

Motor (a)

- 1 = 1-speed
- 2 = *1-Speed star/delta start (Y/D)*
- 3 = *2-Speed*

Speed control (b)

- 0 = *without*
- 1 = fitted frequency inverter
- 2 = integral motor
- 3 = supplied with frequency inverter
- 4 = EC-motor
- 5 = intended for speed control

Connection accessory (c)

- 0 = without
- 1 = safety switch
- 2 = shielded safety switch
- 3 = connection box
- 4 = shielded connection box
- 5 = quick-fit connector
- 6 = safety switch with quick-fit connector

Temperature monitor (d)

- 0 = without
- 1 = thermocontact
- 2 = termistor

Type (e)

- 1 = Standard
- 2 = *Halogen free (marine, power cable)*
- 3 = *Screened cable (power cable)*
- 4 = *Screened halogen free*
- 5 = *SWA*
- 6 = *Rubber sheated cable*
- 7 = *Wires in conduits*

Current (ffff)

- Current in A with one decimal x 10
- 0046 = 4.6 A etc

Length (ggg)

- 100 – 999 length in cm,
- (Function of unit size)

Mains voltage (h)

- 2 = 3x230 VAC
- 4 = 3x400 VAC
- 6 = *3x440 VAC*
- 7 = *3x525 VAC*
- 8 = *3x660 VAC*
- 9 = *3x690 VAC*

Type of unit (i)

- 0 = eQ

Product code

Codes in green italic are included in eQ PLUS

Certificate, air handling unit

CERZ-01-b-1

Language (b)

1 = Swedish

2 = English

Certificate, fans

CERZ-02-b-1

Language (b)

1 = Swedish

2 = English

Certificate, heat exchangers

CERZ-03-b-c-1

Type (b)

1 = product inspection certificate

2 = product inspection certificate + material certificate

3 = product inspection certificate + material certificate
+ welding and X-ray certificate

Language (c)

1 = Swedish

2 = English

Certificate, materials

CERZ-04-b-1

Language (b)

1 = Swedish

2 = English

Certificate, weight

CERZ-05-b-1

Language (b)

1 = Swedish

2 = English

Certificate, air handling unit (Russia)

CERZ-06-1

Certificate of origin

CERZ-07-1

Certificate, inspection

CERZ-08-b-1

Type (b)

1 = Visit by customer

2 = Revision

3 = Exhibition unit

Certificate, tightness

CERZ-09-b-1

Size intervals (b)

1 = Modular block 11-40

2 = Modular block 41-60

3 = Modular block 62-84

We Bring Air to Life

Fläkt Woods is a global leader in air management. We specialise in the design and manufacture of a wide range of air climate and air movement solutions. And our collective experience is unrivalled.

Our constant aim is to provide systems that precisely deliver required function and performance, as well as maximise energy efficiency.

Solutions for all your air climate and air movement needs

Fläkt Woods is providing solutions for ventilation and air climate for buildings as well as fan solutions for Industry and Infrastructure.

● Air Handling Units (AHUs)

Modular, compact and small AHU units. Designed to ensure optimisation of indoor air quality, operational performance and service life.

● Air Terminal Devices and Ducts

Supply and exhaust diffusers and valves for installation on walls, ceiling or floor are all included in our large range and fit all types of applications.

● Chilled Beams

Active induction beams for ventilation, cooling and heating, and passive convection beams for cooling. For suspended or flush-mounted ceiling installation – and multi-service configuration. With unique Comfort Control and Flow Pattern Control features.

● Residential ventilation

A complete range of products for residential ventilation. Consists of ventilation units, exhaust air fans and cooker hoods designed to optimise indoor comfort and save energy.

● Fans

Advanced axial, centrifugal and boxed fans for general and specialist applications. Comprehensive range including high temperature and ATEX compliant options. Engineered for energy efficiency and minimised life cycle cost.

● Chillers

Air-cooled and water-cooled chillers with cooling capacity up to 1800 kW. Designed to minimise annual energy consumption in all types of buildings.

● Controls and drives

Variable speed drives and control systems, all tested to ensure total compatibility with our products. Specialist team can advise on energy saving and overall system integration.

Fläkt Woods Group SA

18, avenue Louis Casati, CH-1209 Geneva, Switzerland
Tel. +41 22 309 3800
email info@flaktwoods.com www.flaktwoods.com

See global web site for international sales offices www.flaktwoods.com

