



Level



Pressure



Flow



Temperature



Liquid  
Analysis



Registration



Systems  
Components



Services



Solutions

## Technical Information

# Liquiphant M FTL50(H), FTL5 1(H)

## Vibration Limit Switch

Level limit switch for all liquids.

Suitable for use in hazardous areas, food and pharmaceuticals



The function is not affected by flow, turbulence, bubbles, foam, vibration, bulk solids content or build-up. The Liquiphant is thus the ideal substitute for float switches.

### FTL50:

Compact design, ideal for mounting in pipes and for installation in areas difficult to access

### FTL51:

With extension pipe up to 3 m (6 m on request)

### FTL50H, FTL51H:

With polished tuning fork and easy-to-clean process connections and housings for food and pharmaceutical applications.

High corrosion-resistant AlloyC4 (2.4610) is available for the fork and process connections for applications in very aggressive liquids.

EEx ia, EEx de and EEx d protection enable it to be used in hazardous areas.

### Your benefits

- 
- 
-

### Application

The Liquiphant M is a level limit switch for use in all liquids

- for process temperatures of  $-50\text{ }^{\circ}\text{C}$  to  $150\text{ }^{\circ}\text{C}$
- for pressures up to 100 bar
- for viscosity up to  $10000\text{ mm}^2/\text{s}$
- for densities  $0.5\text{ g/cm}^3$  or  $0.7\text{ g/cm}^3$  other settings available on request
- foam detection on request

Use in safety systems requiring functional safety to SIL2/SIL3 in accordance with IEC 61508/ IEC 61511-1

Large number of process connections to choose from: universal usage

Wide variety of electronics, e.g. NAMUR, relay, thyristor, PFM signal output: the right connection for every process control system

- PROFIBUS PA protocol:
  - for commissioning and maintenance
- No calibration: quick, low-cost start-up
- No mechanically moving parts: no maintenance, no wear, long operating life
- Monitoring of fork for damage: guaranteed function
- FDA approved materials (PFA Edlon)

---

## Application

---

### Level limit detection

Maximum or minimum detection in tanks or pipes containing all kinds of liquids, including use in hazardous areas, food and pharmaceuticals

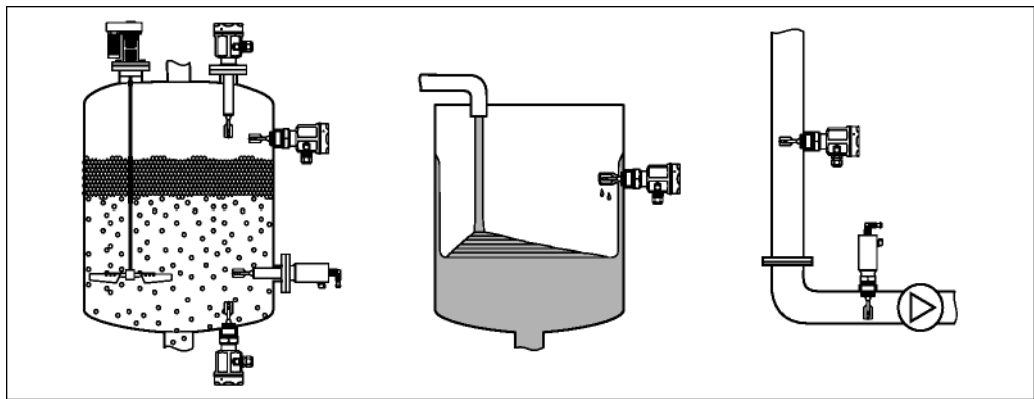

100-FTL5xxxx-11-05-xx-xx-000

## unction and system design

### Measuring principle

The sensor's fork vibrates at its intrinsic frequency.  
This frequency is reduced when covered with liquid. The change in frequency then activates a limit switch.

### Modularity

#### Level limit switch

Liquiphant M FTL with electronic versions  
FEL51, FEL52, FEL54

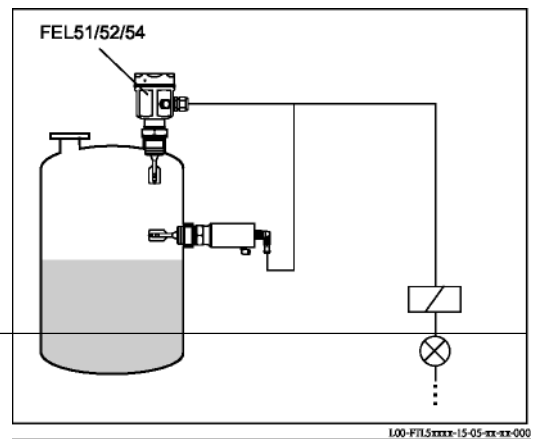

#### Level sensor

Liquiphant M FTL with electronic versions  
FEL55, FEL56, FEL57, FEL58

for connecting to a separate switching unit or or  
an isolating amplifier FEL50A  
for connecting to PROFIBUS PA segment

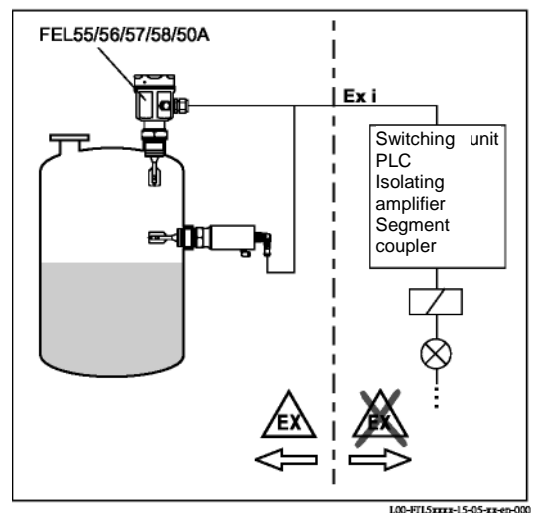

**Electronic versions for level limit switches**

FEL51:  
Two-wire AC version;  
Switch the load directly into the power supply circuit via the thyristor.

FEL52:  
Three-wire DC version;  
Switch the load via the transistor (PNP) and separate connection.

FEL54:  
Universal current version with relay output;  
Switch the loads via 2 floating change-over contacts.

---

**Electronic versions for level sensor**

FEL55:  
For separate switching unit; signal transmission 16/8 mA along two-wire cabling.

FEL56:  
For separate switching unit; signal transmission L-H edge 0.6...1.0/ 2.2...2.8 mA to EN 50227 (NAMUR) along two-wire cabling.

FEL58:  
For separate switching unit; signal transmission H-L edge 2.2...3.5/ 0.6...1.0 mA to EN 50227 (NAMUR) along two-wire cabling.  
Checking of connecting cabling and other devices by pressing a key on the electronic insert.

FEL57:  
For separate switching unit; PFM signal transmission;  
Current pulses superposed on the power supply along the two-wire cabling.  
Cyclical checking from the switching unit without changing levels.

FEL50A:  
For connecting to PROFIBUS PA;  
Cyclic and acyclic data exchange acc. to PROFIBUS PA Profile 3.0 Discrete Input

---

**Galvanic isolation**

FEL51, FEL52, FEL50A:  
Between sensor and power supply

FEL54:  
Between sensor and power supply and load

FEL55, FEL56, FEL57, FEL58: See Switching unit connected

---

**Design**

FTL50:  
Compact

FTL5 1:  
With extension pipe

FTL50H:  
Compact, with polished tuning fork and hygienic process connections

FTL51H:  
With extension pipe, polished tuning fork and hygienic process connections

## Input

---

**Measured variable**

Level (limit value)

---

**Measuring range (detection range)**

FTL50:  
Depends on mounting point.

FTL5 1:  
Depends on mounting point and the pipe extension. Standard 3000 mmm (up to 6000 mm on request)

---

**Product density**

Adjustment on the electronic insert > 0.5 g/cm<sup>3</sup> or > 0.7 g/cm<sup>3</sup> (other on request)

---

## Electronic insert FEL5 1 (AC 2-wire)

### Power supply

Supply voltage: 19...253 V AC  
 Power consumption: < 0.83 W  
 Residual current consumption: < 3.8 mA  
 Short-circuit protection  
 FEM51 overvoltage protection: overvoltage category III

### Electrical connection

#### Two-wire AC connection

Always connect in series with a load!

Check the following:

- The residual current in blocked state (up to 3.8 mA)
- that for low voltage
  - the voltage drop across the load is such that the minimum terminal voltage at the electronic insert (19 V) when blocked is not undershot.
  - the voltage drop across the electronics when switched through is observed (up to 12 V)
- that a relay cannot de-energise with holding power below 3.8 mA.  
 If this is the case, a resistor should be connected parallel to the relay. (RC module available on request).
- When selecting the relay, pay attention to the holding power/rated power (See "Connectable load")

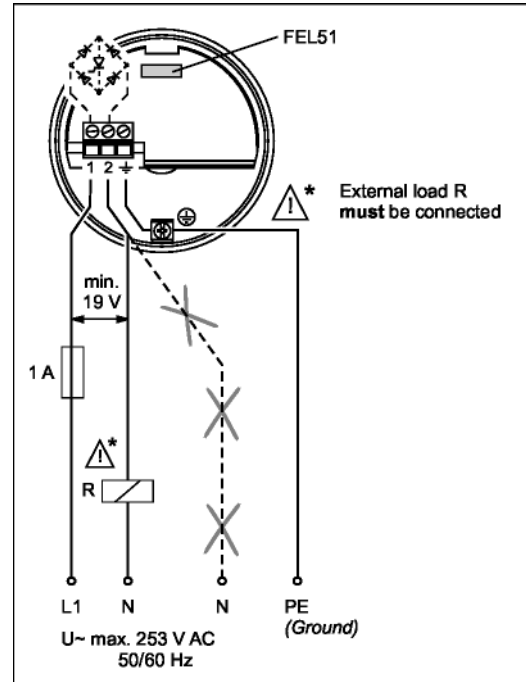

L00-FTL5xxxx-04-05-xx-en-007

### Output signal

$I_L$  = load current (switched through)

< 3.8 mA = residual current (blocked)



= lit



= unlit

L00-FTL2xxxx07-05-xx-xx-000

Safety mode	Level	Output signal	LEDs
Max.		1 $I_L$ 2	
		1 < 3.8 mA 2	
Min.		1 $I_L$ 2	
		1 < 3.8 2	

L00-FTL5xxxx-04-05-xx-xx-001

### Signal on alarm

Output signal on power failure or in the event of damaged sensor: < 3.8 mA

### Connectable load

- For relays with a minimum holding power/rated power > 2.5 VA at 253 V AC (10 mA) or > 0.5 VA at 24 V AC (20 mA)
- Relays with a lower holding power/rated power can be operated by means of an RC module connected in parallel
- For relays with a maximum holding power/rated power < 89 VA at 253 V AC or < 8.4 VA at 24 V AC
- Voltage drop across FEL51 max. 12 V
- Residual current with blocked thyristor max. 3.8 mA
- Load switched directly into the power supply circuit via the thyristor.  
 Transient (40 ms) max. 1.5 A, max. 375 VA at 253 V or max. 36 VA at 24 V (not short-circuit proof)

## Electronics FEL51 (AC, in compact housing)

**Power supply**

Supply voltage: 19...253 V AC  
 Power consumption: < 0.83 W  
 Residual current consumption: < 3.8 mA  
 Short-circuit protection  
 FEM5 1 overvoltage protection: overvoltage category III

**Electrical connection**

**Two-wire AC connection**

Always connect in series with a load!

Check the following:

- The residual current in blocked state (up to 3.8 mA)
- that for low voltage
  - the voltage drop across the load is such that the minimum terminal voltage at the electronic insert (19 V) when blocked is not undershot.
  - the voltage drop across the electronics when switched through is observed (up to 12 V).
- That a relay cannot de-energise with holding power below 3.8 mA. If this is the case, a resistor should be connected parallel to the relay.

(RC module available on request).

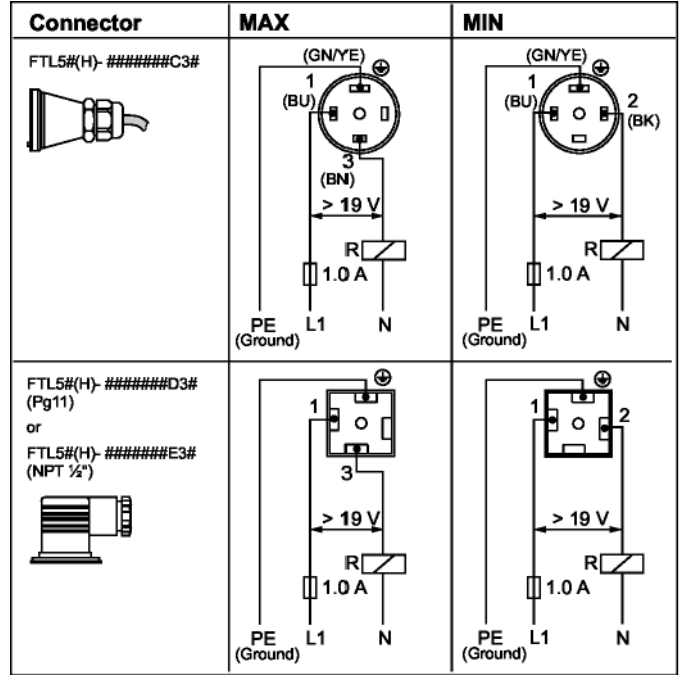

L00-FTL5xxxx-04-05-xx-en-008

**Output signal**

$I_L$  = load current (switched through)

< 3.8 mA = residual current (blocked)









= lit

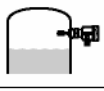

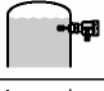
= unlit

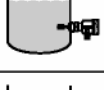
L00-FTL2xxxx-07-05-xx-xx-000

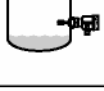
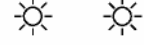
Safety mode	Level	Output signal	LEDs
Max.		$I_L$	
		< 3.8 mA	
Min.		$I_L$	
		< 3.8	

L00FTL5xxxx-0405-xx-xx-001a

**Signal on alarm**

Output signal on power failure or in the event of damaged sensor: < 3.8 mA

**Connectable load**

- For relays with a minimum holding power/rated power > 2.5 VA at 253 V AC (10 mA) or > 0.5 VA at 24 V AC (20 mA)
- Relays with a lower holding power/rated power can be operated by means of an RC module connected in parallel
- For relays with a maximum holding power/rated power < 89 VA at 253 V AC or < 8.4 VA at 24 V AC
- Voltage drop across FEL51 max. 12 V
- Residual current with blocked thyristor max. 3.8 mA
- Load switched directly into the power supply circuit via the thyristor.  
 Transient (40 ms) max. 1.5 A, max. 375 VA at 253 V or max. 36 VA at 24 V (not short-circuit proof)

## Electronic insert FEL52 (DC PNP)

### Power supply

Supply voltage: 10...55 V DC  
 Ripple: max. 1.7 V, 0...400 Hz  
 Current consumption: max. 15 mA  
 Power consumption: max. 0.83 W  
 Reverse polarity protection  
 Overvoltage protection FEL52: overvoltage category III

### Electrical connection

#### Three-wire DC connection

Preferably used with programmable logic controllers (PLC).  
 DI module as per EN 61131-2.  
 Positive signal at switching output of the electronics (PNP);  
 Output blocked on reaching limit.

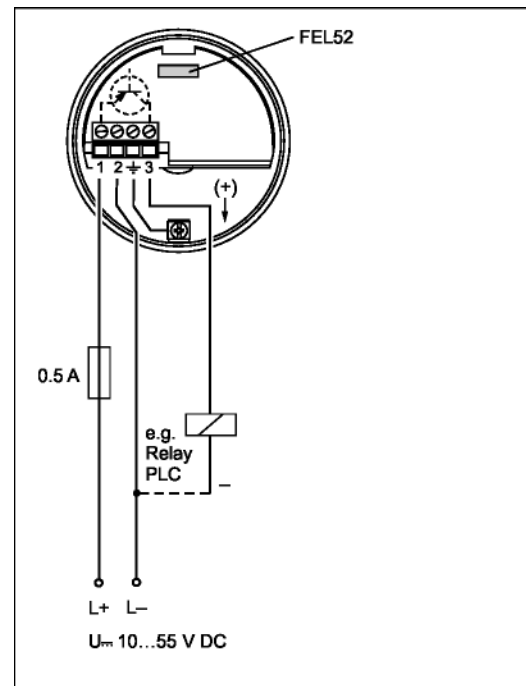

L00-FTL5xxxx-04-05-xx-en-001

### Output signal

$I_L$  = load current (switched through)

$< 100 \mu A$  = residual current (blocked)

= lit

= unlit

L00-FTL2xxxx07-05-xxxx-000

Safety mode	Level	Output signal	LEDs
Max.		$I_L$ (L+ 1 to + 3)	
		$< 100 \mu A$ (L+ 1 to 3)	
Min.		$I_L$ (L+ 1 to + 3)	
		$< 100 \mu A$ (L+ 1 to 3)	

L00-FTL5xxxx-04-05-xx-xx-004

### Signal on alarm

Output signal on power failure or in the event of damaged sensor:  $< 100 \mu A$

### Connectable load

- Load switched via the transistor and separate PNP connection, max. 55 V DC
- Load current max. 350 mA (pulsed overload and short-circuit protection)
- Residual current  $< 100 \mu A$  (with transistor blocked)
- Capacitive load max. 0.5  $\mu F$  at 55 V, max. 1.0  $\mu F$  at 24 V
- Residual voltage  $< 3 V$  (with transistor switched through)

## Electronics FEL52 (DC PNP, in compact housing)

### Power supply

Supply voltage: 10...55 V DC  
 Ripple: max. 1.7 V, 0...400 Hz  
 Current consumption: max. 15 mA  
 Power consumption: max. 0.83 W  
 Reverse polarity protection  
 Overvoltage protection FEL52: overvoltage category III

### Electrical connection

#### Three-wire DC connection

Preferably used with programmable logic controllers (PLC).  
 DI module as per EN 61131-2.  
 Positive signal at switching output of the electronics (PNP);  
 Output blocked on reaching limit.

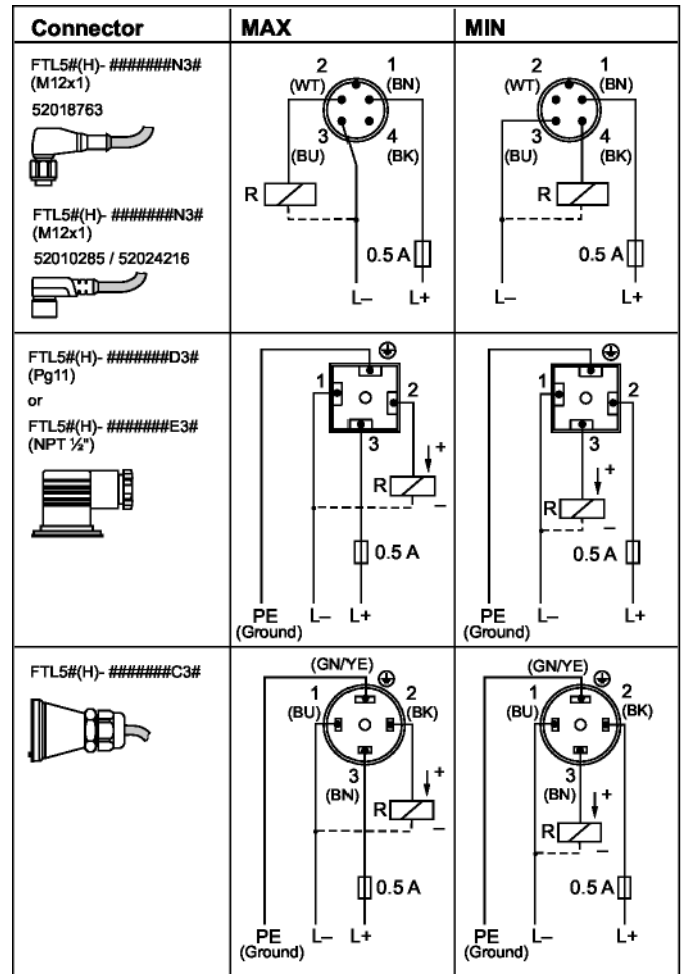

L00-FTL5xxxx-04-05-xx-xx-010

### Output signal

#### With valve connector or cable tail

$I_L$  = load current (switched through)





$< 100 \mu A$  = residual current (blocked)



= lit

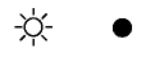
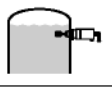
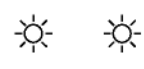
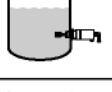

= unlit

Safety mode	Level	Output signal	LEDs
Max.		$L+ \xrightarrow{I_L} 2$	
		$L+ < 100 \mu A \xrightarrow{+} 2$	
Min.		$L+ \xrightarrow{I_L} 3$	
		$L+ < 100 \mu A \xrightarrow{+} 2$	

L00-FTL2xxxx-07-05-xx-xx-000

L00-FTL5xxxx-04-05-xx-xx-004a

With M12x1 connector 52010285 / 52024216 (without LEDs)



100-FT15xxxx-16-05-  
xx-xx-002

$I_L$  = load current

< 100  $\mu$ A = residual current (blocked)



= lit



= unlit

100-FT12 xxxx07 -05-  
xx-xx-000

Safety mode	Level	Output signal	LEDs
Max		$L + \xrightarrow{1} - 2$	
		$\leq 1 \text{ } 0^+ 0 \text{ } \mu \text{ A} \xrightarrow{2}$	
Min		$L + \xrightarrow{1} - 4$	
		$\leq 1 \text{ } 0^+ 0 \text{ } \mu \text{ A} \xrightarrow{4}$	

100-FT15xxxx-04-05-xx-xx-010

With M12x1 connector 52018763 (with LEDs)

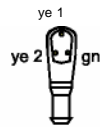

100-FT15xxxx-16-05-  
xx-xx-001

$I_L$  = load current (switched through)

< 100  $\mu$ A = residual current (blocked)



= lit



= unlit

100-FT12 xxxx07 -05-  
xx-xx-000

Safety mode	Level	Output signal	LEDs
Max		$L + \xrightarrow{1} - 2$	
		$\leq 1 \text{ } 0^+ 0 \text{ } \mu \text{ A} \xrightarrow{2}$	
Min		$L + \xrightarrow{1} - 4$	
		$\leq 1 \text{ } 0^+ 0 \text{ } \mu \text{ A} \xrightarrow{4}$	

100-FT15xxxx-04-05-xx-xx-011

Signal on alarm

Output signal on power failure or in the event of damaged sensor: < 100  $\mu$ A

Connectable load

- Load switched via the transistor and separate PNP connection, max. 55 V DC
- Load current max. 350 mA (pulsed overload and short-circuit protection)
- Residual current < 100  $\mu$ A (with transistor blocked)
- Capacitive load max. 0.5  $\mu$ F at 55 V, max. 1.0  $\mu$ F at 24 V
- Residual voltage < 3 V (with transistor switched through)

## Electronic insert FEL54 (AC/DC with relay output)

### Power supply

Supply voltage: 19...253 V AC, 50/60 Hz or 19...55 V DC  
 Power consumption: max. 1.3 W  
 Reverse polarity protection  
 Overvoltage protection FEL54: overvoltage category III

### Electrical connection

#### Universal current connection with relay output

##### Power supply:

Please note the different voltage ranges for AC and DC.

##### Output:

When connecting an instrument with high inductance, provide a spark arrester to protect the relay contact.

A fine-wire fuse (depending on the load connected) protects the relay contact on short-circuiting.

Both relay contacts switch simultaneously.

\* When jumpered, the relay output works with NPN logic.

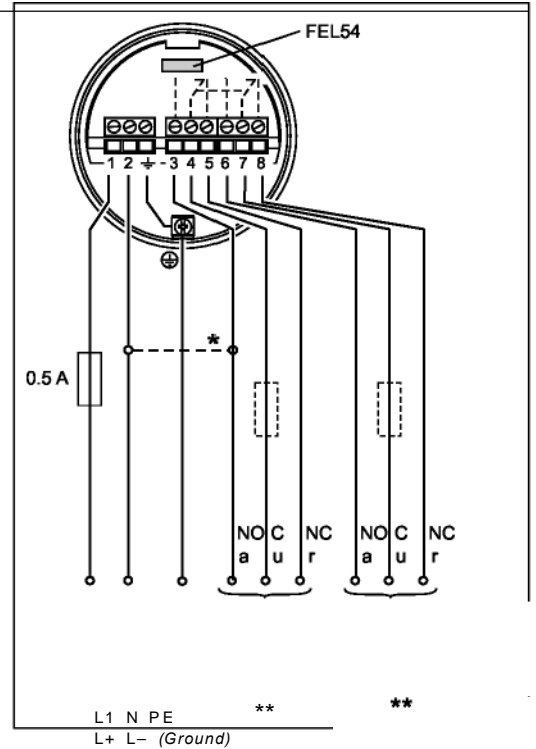

U~ 19...253 V AC, 50/60 Hz

Safety mode	Level	Output signal		LEDs	
		3 4 5	6 7 8	green	red
Max.					
Min.					

100-FIL2xxxx-07-05-xx-xx-001

- = relay energised
- = relay de-energised
- = lit
- = unlit

### Output signal

#### Signal on alarm

Output signal on power failure or in the event of damaged sensor: relay de-energised

#### Connectable load

- Loads switched via 2 floating change-over contacts (DPDT)
- I~ max. 6 A (EEx d 4 A), U~ max. 253 V AC; P~ max. 1500 VA, cos  $\phi$  = 1, P~ max. 750 VA, cos  $\phi$  > 0.7
- I% max. 6 A (EEx d 4 A) to 30 V, I% max. 0.2 A to 125 V
- When connecting a low-voltage circuit with double isolation according to IEC 1010 the following applies: total of voltages of relay output and power supply max. 300 V

## Electronic insert FEL55 (8/16 mA)

### Power supply

Supply voltage: 11 ...36 V DC  
 Power consumption: < 600 mW  
 Reverse polarity protection  
 Overvoltage protection FEL55: overvoltage category III

### Electrical connection

#### Two-wire connection for separate switching unit

For connecting to programmable logic controllers (PLC).  
 AI module 4...20 mA to EN 61131-2.  
 Output signal jump from high to low current on limit.

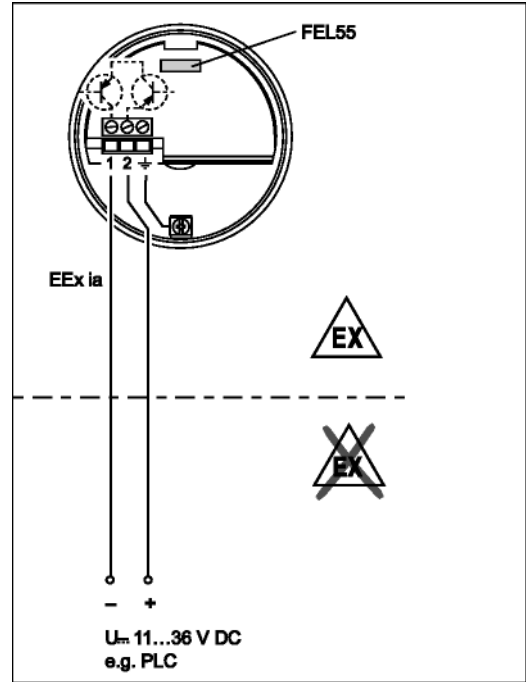

L00-FTL5xxxx-04-05-xx-en-000

### Output signal

~ 16 mA = 16 mA ± 5 %

~ 8 mA = 8 mA ± 6 %  
 = lit



= unlit

L00-FTL2xxxx07-05-  
 xx-xx-000

Safety mode	Level	Output signal	LEDs
Max.		2 ..... 1	
		+ 2 → ~ 8 mA 1	
Min.		+ ~ 16 mA 2 1	
		+ 2 → ~ 8 mA	

L00-FTL5xxxx-04-05-xx-xx-000

### Signal on alarm

Output signal on power failure or in the event of damaged sensor: < 3.6 mA

### Connectable load

- $R = (U - 11 \text{ V}) : 16.8 \text{ mA}$
- $U = \text{connection voltage: } 11 \dots 36 \text{ V DC}$

## Electronic insert FEL56 (NAMUR L-H edge)

**Power supply**

Power consumption: < 6 mW bei I < 1 mA; < 38 mW bei I = 2,2...4 mA  
 Connection data interface: IEC 60947-5-6

**Electrical connection**

**Two-wire connection for separate switching unit**

For connecting to isolating amplifiers acc. to NAMUR (IEC 60947-5-6), e.g. FXN421, FXN422, FTL325N, FTL375N or Commutec SIN100, SIN110 from Endress+Hauser. Output signal jump from low to high current on limit.

**(L-H edge)**

Connecting to multiplexer: Set clock time to min. 2 s.

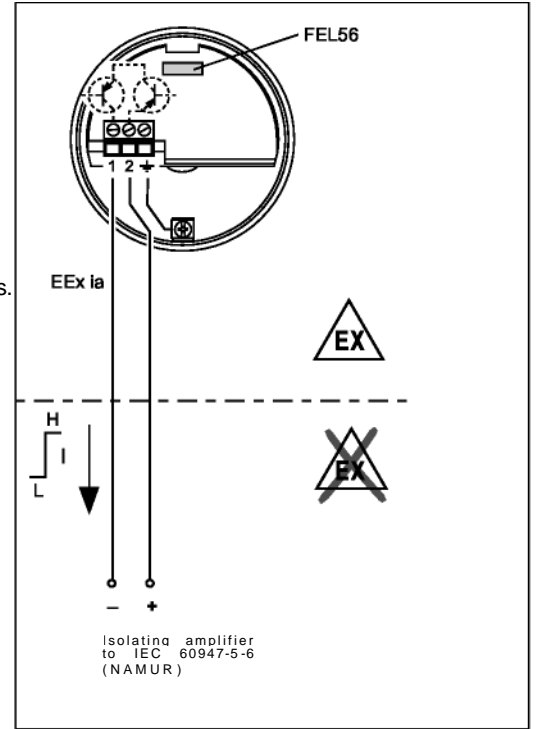

L00-FTL5xxxx-04-05-xx-en-004

**Output signal**

- = lit
- = flashes
- = unlit

L 00-FTL5xxxx 07-05 - xx xx 002

	Safety mode Level	Output signal	LEDs	
			green	red
Max.		+ 0.6 ... 2 1.0 mA 1		
		+ 2.2 ... 2 2.8 mA 1		
Min.		+ 0.6 ... 2 1.0 mA 1		
		+ 2.2 ... 2 2.8 mA 1		

L00-FTL5xxxx-04-05-xx-xx-003

**Signal on alarm**

Output signal in the event of damaged sensor: > 2.2 mA

**Connectable load**

- See Technical Data of isolating amplifier connected according to IEC 60947-5-6 (NAMUR)

## Electronic insert FEL58 (NAMUR H-L edge)

### Power supply

Power consumption: < 6 mW bei I < 1 mA; < 38 mW bei I = 2,2...4 mA  
 Connection data interface: IEC 60947-5-6

### Electrical connection

#### Two-wire connection for separate switching unit

For connecting to isolating amplifiers acc. to NAMUR (IEC 60947-5-6), e.g. FXN421, FXN422, FTL325N, FTL375N or Commutec SIN100, SIN110 from Endress+Hauser. Output signal jump from high to low current on limit.

#### (H-L edge)

Additional function:  
 Test key on the electronic insert.  
 Pressing the key breaks the connection to the isolating amplifier.

#### ! Note!

For Ex-d applications, the additional function can only be used if the housing is not exposed to an explosive atmosphere.

Connecting to multiplexer: Set clock time to min. 2 s.

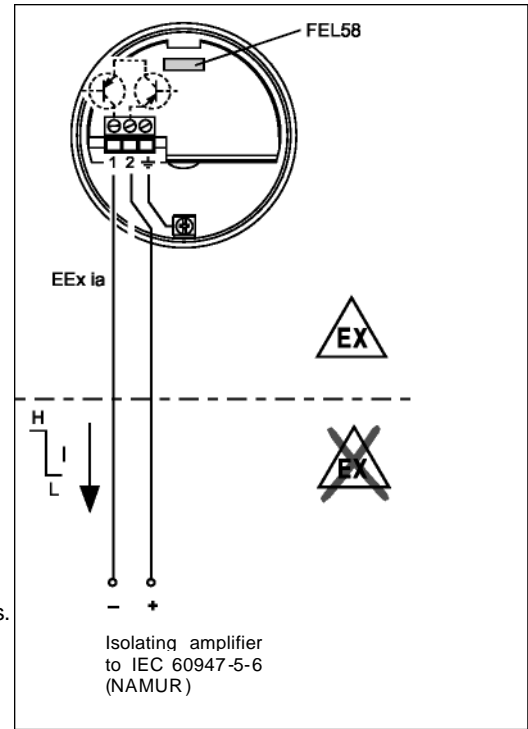

L00-FTL5xxxx-04-05-xx-en-002

### Output signal

☀ = lit  
 ⚡ = flashes  
 ● = unlit

L00-FTL5xxxx-07-05-xx-xx-002

	Safety mode Level	Output signal	LEDs green yellow
Max.		$\frac{+}{2} \begin{matrix} 2.2 \dots \\ 3.5 \text{ mA} \\ 1 \end{matrix}$	☀ ☀
		$\frac{+}{2} \begin{matrix} 0.6 \dots \\ 1.0 \text{ mA} \\ 1 \end{matrix}$	⚡ ●
Min.		$\frac{+}{2} \begin{matrix} 2.2 \dots \\ 3.5 \text{ mA} \\ 1 \end{matrix}$	☀ ☀
		$\frac{+}{2} \begin{matrix} 0.6 \dots \\ 1.0 \text{ mA} \\ 1 \end{matrix}$	⚡ ●

L00FTL5xxxx-04-05-xx-xx-007

### Signal on alarm

Output signal in the event of damaged sensor: < 1.0 mA

### Connectable load

• See Technical Data of isolating amplifier connected according to IEC 60947-5-6 (NAMUR) •  
 Connection also to isolating amplifiers which have special safety circuits (I > 3.0 mA)