



These DE-STA-CO Precision Manual Clamps are used in applications requiring a higher level of precision and repeatability over our standard clamping products. These clamps feature components manufactured to a higher level of precision and include features that make them the preferred choice for applications such as automotive prototype production jigs and as locating devices.

Model	Holding capacity	Page
	<p>614-M</p> <p>5000N [1125lbf]</p>	<p>5.2</p>
	<p>670-1MBPLS 675-1MBPLS 690-1MBPLS 695-1MBPLS</p> <p>10680N [2400lbf] 10680N [2400lbf] 22240N [5000lbf] 22240N [5000lbf]</p>	<p>5.4</p>
	<p>52H-5</p> <p>160Nm [120ft-lbf]</p>	<p>5.6</p>
	<p>52H05-6</p> <p>1000Nm [735ft-lbf]</p>	<p>5.8</p>
	<p>56H4-2</p> <p>---</p>	<p>5.15</p>

Series 614 Product Overview

Features:

- Single hole threaded mount or side mount
- Precision hardened and ground plunger is designed for anti-rotation under torsional loads
- Locks in the extended or retracted position

Applications:

- Assembly
- Checking fixtures
- Locaters and positioners

Also Available:

See page 8.1 for accessories

614-M



Series 614 Technical Information, Holding Capacities, Standard Clamp Dimensions

Model	Max. Holding Capacity	Weight	Plunger Travel	Plunger Thread	Mounting Nut (Supplied)
614-M	[1125 lbf] 5000 N	[1.81lb] 0,82kg	[1.26] 32	M8	614-1-10

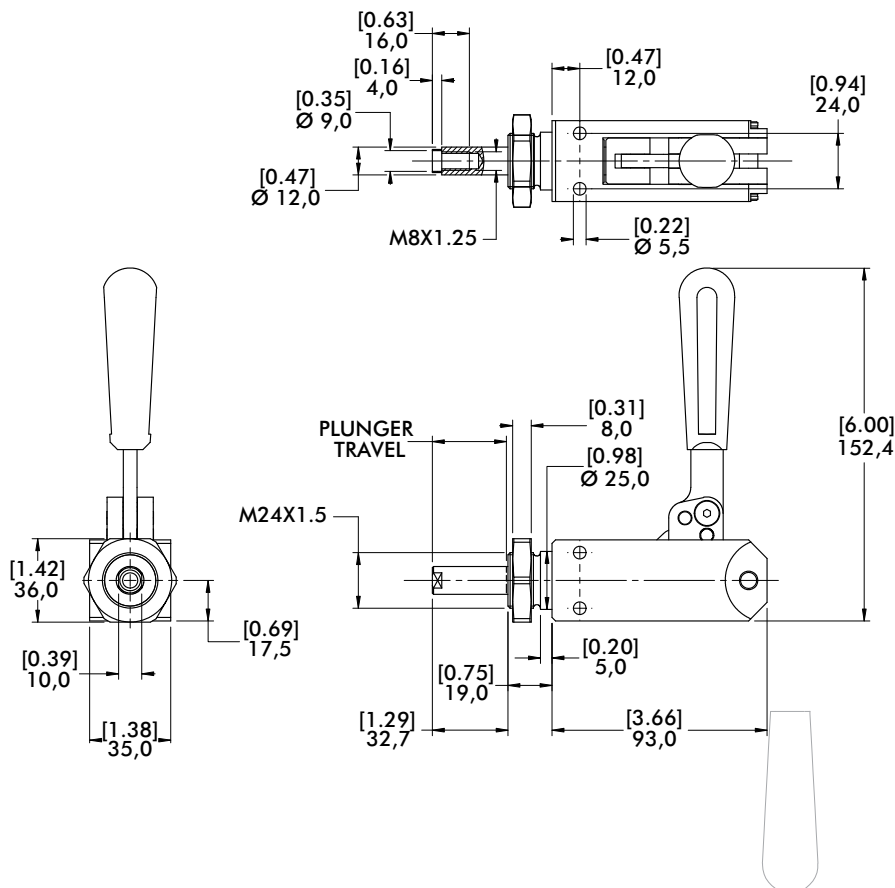

Series 670, 675, 690, 695 Product Overview

Features:

- Precision clamping for high production
- Adjustable collet-type bushing minimizes radial plunger movement
- Plunger has a flat surface for anti rotation
- Pre-load nut and hold open device included

Applications:

- Assembly
- Welding

670-1MBPLS



675-1MBPLS



690-1MBPLS



695-1MBPLS ⓘ



Series 670, 675, 690, 695 Technical Information, Holding Capacities

Model	Max. Holding Capacity	Weight	Plunger Travel	Plunger Thread
670-1MBPLS	[2400 lbf] 10680 N	[4.2lb] 1,91 kg	[2.25] 57,2	M12
675-1MBPLS		[4.0lb] 1,81 kg	[1.10] 28	
690-1MBPLS	[5000 lbf] 22240 N	[8.2lb] 3,72kg	[3.00] 76,2	M16
695-1MBPLS ⓘ		[7.2lb] 3,27kg	[1.50] 38,1	

ⓘ This item is available upon request

Series 670, 675, 690, 695 Standard Clamp Dimensions

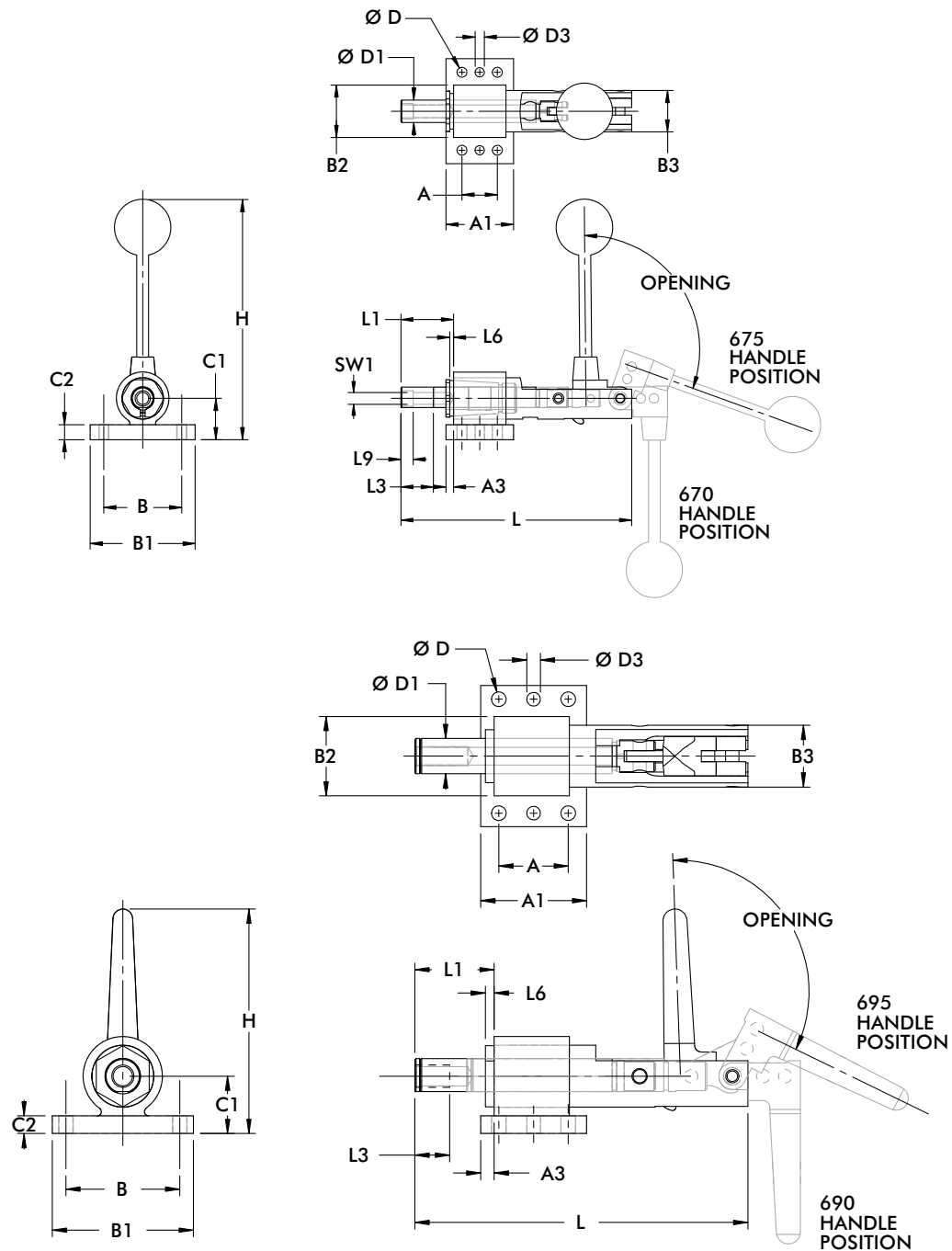

Model	A	A1	A3	B	B1	B2	B3	C1	C2	ØD	ØD1	ØD3	H	L	L1	L3	L6	L9	SW1
670-1MB														268	75.5				
670-1MBPLS	30	57	6.4	66	89	44.5	35	34.8		8.4	19	7.8	206			35		10.3	13H
675-1MB														195	44.4				7
675-1MBPLS									12.7								0-8		
690-1MB														338	85.9				
690-1MBPLS	50	76.2	9.5	82	102	-	44.4	41.3		10.5	25	9.8	162			25		-	-
695-1MB														240	47.8				
695-1MBPLS																			

Series **52H50** Product Overview

Manual Clamp interchangeable with 82M-6

Manual clamp with toggle lock mechanism is interchangeable with 82M-6 in application and operating dimensions.

Application

- Mainly in jigs for Automotive prototype production

Technical features

- Robust steel device
- Different clamping arm dimensions available
- Clamping arm mountable in horizontal or vertical position
- Compact design
- Opening angle adjustable by using hold open device
- Hold open device available

Technical data

- Standard opening angle 120°
- Holding capacity 160Nm
- Weight 5,0 kg

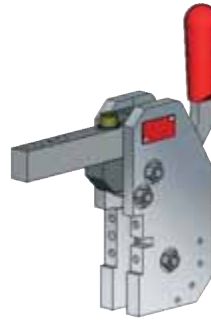

52H50-503-2-0
Clamping position horizontal



52H50-543-2-0
Clamping position vertical

Order no. Code for **52H50-5...**

Example Order no.: **52H50** - **503** - **2** - **A**

<p>90° - Version</p> <p>180° - Version</p>	<p>Horizontal</p> <p>Vertical</p>	<p>0 = without locking device</p> <p>A = locking device with spring loaded pin</p> <p>(two hand unlocking device)</p> <p>B = locking device with clip</p>
<p>Basic model</p>	<p>Clamp arms</p>	<p>Locking device</p>

Series 52H50 Standard Dimensions

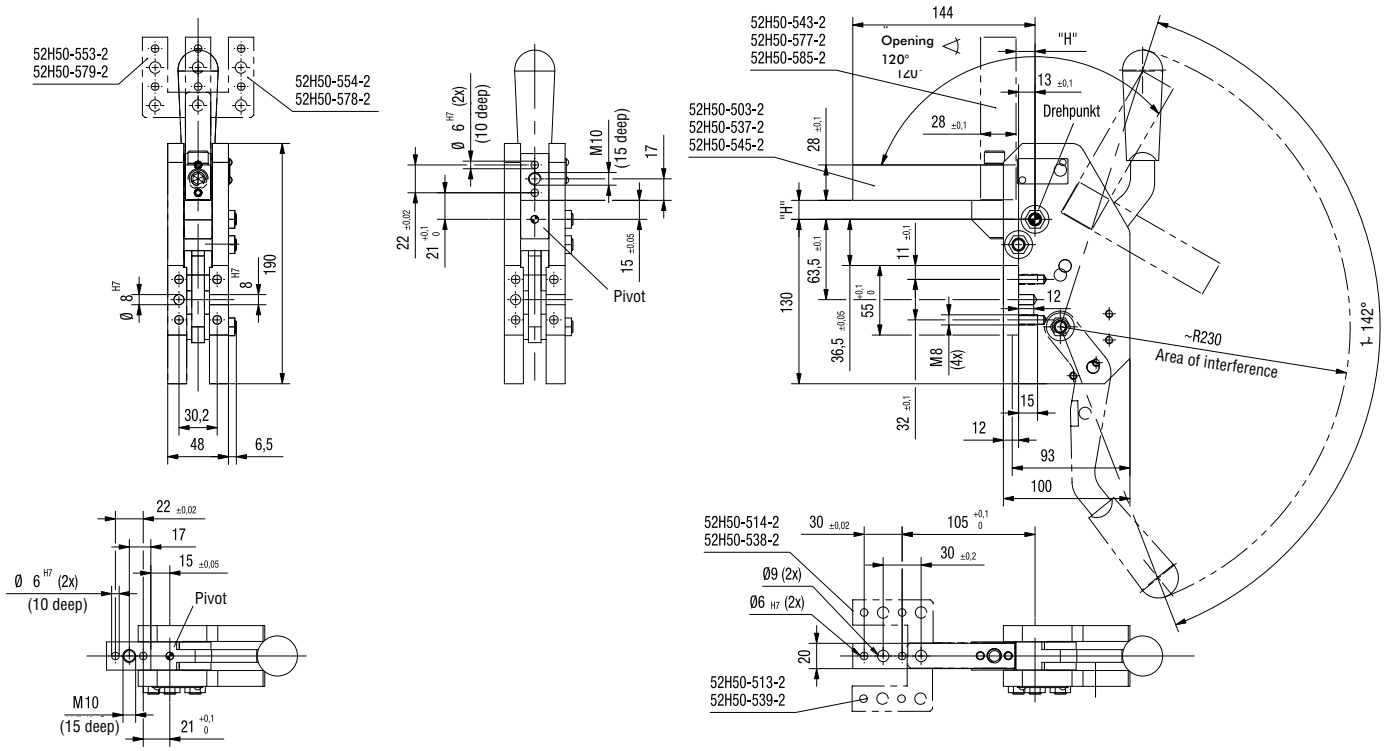

Model	Opening angle	Weight ~ (kg)	Holding capacity max. (Nm)	Clamping arm position	"H"	
52H50-503-2- 52H50-543-2- 52H50-537-2- 52H50-577-2- 52H50-545-2- 52H50-585-2-	120°	5	160	central	15	
52H50-513-2- 52H50-553-2- 52H50-539-2- 52H50-579-2- 52H50-514-2- 52H50-554-2- 52H50-538-2- 52H50-578-2-					left	15
						25
						15
						25
						15
				25		
				15		
				25		

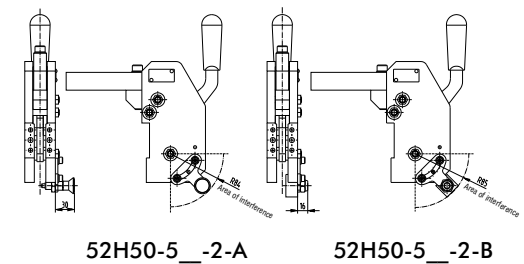
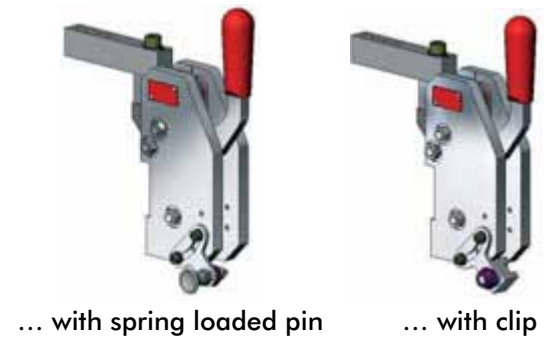

Spare parts

Description	Order no.
Handle	250301

Accessories (for belated mounting)

Description	Order no.
Hold open device „A“	52H50-5-2-A
Hold open device „B“	52H50-5-2-B

Series **52H05-6** Product Overview

Modular Manual Clamp

Applications

Clamping, holding, gripping and positioning of metal sheets and other parts, mainly in jigs for prototype-shop

Features

- Compact closed aluminium body
- Toggle action mechanism with locking unit for open position
- Handlever can be welded in correct position
- Handlever can be mounted left or right side of body
- Interchangeable with pneumatic clamp 82M-6

- Opening angle adjustable in 15° steps (15°–120°)
- Wide range of clamping arm variants
- Mounting areas of front, back and sides
- Inductive sensing module with LED display



52H05-623KAA
Modular manual clamp, interchangeable with 82M-6

Model		Standard	Max. holding torque Nm	Drive shaft for clamping arm variant	Clamping position	Weight Kg
without sensing	with inductive sensing opening Connector M12x1 fixed angle					
52H05-623KAA	52H05-623KA1/ 52H05-623KA2	120°	1000	lateral, U-centric/ U-side	horizontal/ vertical	4,1
52H05-623SAA	52H05-623SA1/ 52H05-623KA2	120°	1000	lateral, U-centric/ U-side	horizontal/ vertical	4,1

Order numbering code for **52H05-6.....**

Example Order no.: **52H05 - 623 K AA**

<p>52H05-623</p> <p>Basic model</p>	<p>K = with handlever welded. Handlever-Set 8KB-053-1</p> <p>S = Handlever weldable Handlever-Set 8KB-052-1</p> <p>Handlever</p>	<p>AA = without sensing 82M-000000AA (8AB-066-2)</p> <p>A1 = inductive sensing 82M-000000A1 Fabr. Turck</p> <p>A2 = inductive sensing 82M-000000A2 Fabr. Pepperl & Fuchs</p> <p>Sensing system</p>	<p>Accessory Two hand operation 82ZB-032-2</p> <p>Assembly at hold open pin is possible on rear side or lateral side.</p> <p>Accessories</p>
--	---	--	---

Series 52H05-6 Standard Dimensions

Spare parts

Specification	Structure component	Order no.	Comment
Hand lever set (weldable)	52H05-6...	8KB-052-1	
Hand lever set welded	52H05-6...	8KB-053-1	
Complete sensor box for A1 sensing system	52H05-6...A1	82M-000000A1	Fabr. Turck
Box without sensors	52H05-6...AA	82M-000000AA	
Complete sensor box for A2 sensing system	52H05-6....A2	82M-000000A2	Fabr. Pepperl and Fuchs

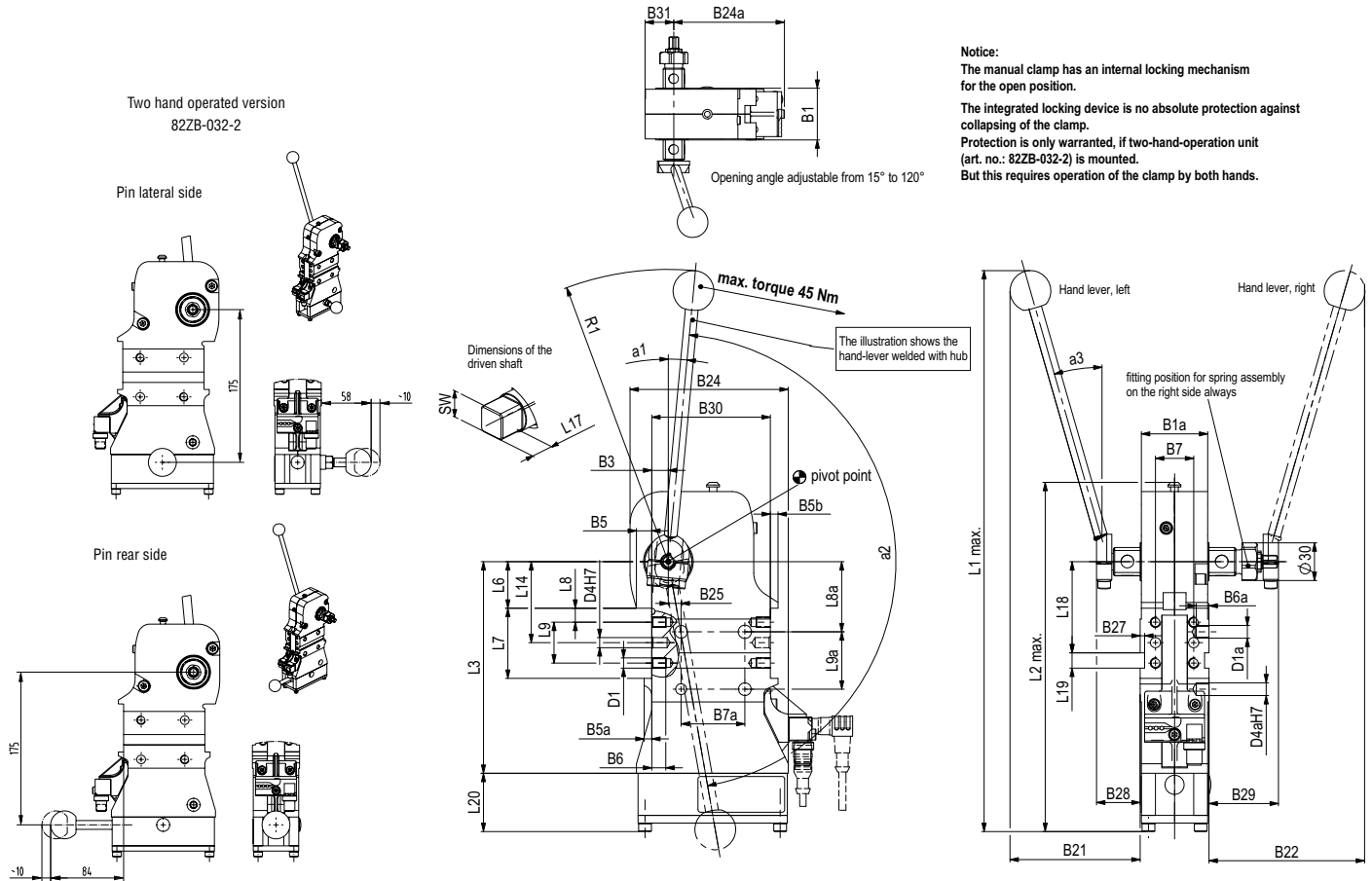

Model	B1	B1	B3	B5	B5 α	B5b	B6	B6 α	B7*	B7 α *	B22	B24	B24 α	B25	B27	B28	B29	B30	B31	D1	D1 α
52H05-6230...	54	52	13	12	6	6	11	9	30	50	100	119	119	10	3,5	36	54	93	30	M8	M10

Model	D4	D4 α	L1	L2	L3	L6	L7	L8	L8 α	L9	L9 α	L14	L17	L18	L19	L20	SW	α 1	α 2	α 3	R1
52H05-6230...	8	10	366	260	166	36,5	55	11	55	32	45	63,5	21	71,5	12	30	22	5°	160°	16°	240

Series **52H05-6** Clamping Arm Variants

Clamping arm design

U-type central clamping arm

Clamping position

Horizontal or Vertical



U-type central clamping arm, horizontal clamping position

Technical data U-type central clamping arms

Model	Order no. for set of U-type central clamping arms	Max. opening angle for clamping position		Weight Kg	B2	B4	B9	B10	B11	B12	B26	D2	D3	L4	L5	L10	R1
		Horz.	Vert.														
52H05-6	8UM 631-15-144	120°	105°	1,1	144	64.3	9	30	105	30	95	6	9	28	15	20	80
	8UM 631-25-144	120°	120°	1,1	144	64.3	9	30	105	30	95	6	9	28	25	20	80
	8UM 631-45-144	120°	120°	1,3	144	64.3	9	30	105	30	95	6	9	28	45	20	80
	8UM 631-75-204	120°	120°	1,7	204	82	9	30	165	30	107	6	9	30	75	20	80

U-type central clamping arms for **52H05-6**

Horizontal clamping arm position

Vertical clamping arm position

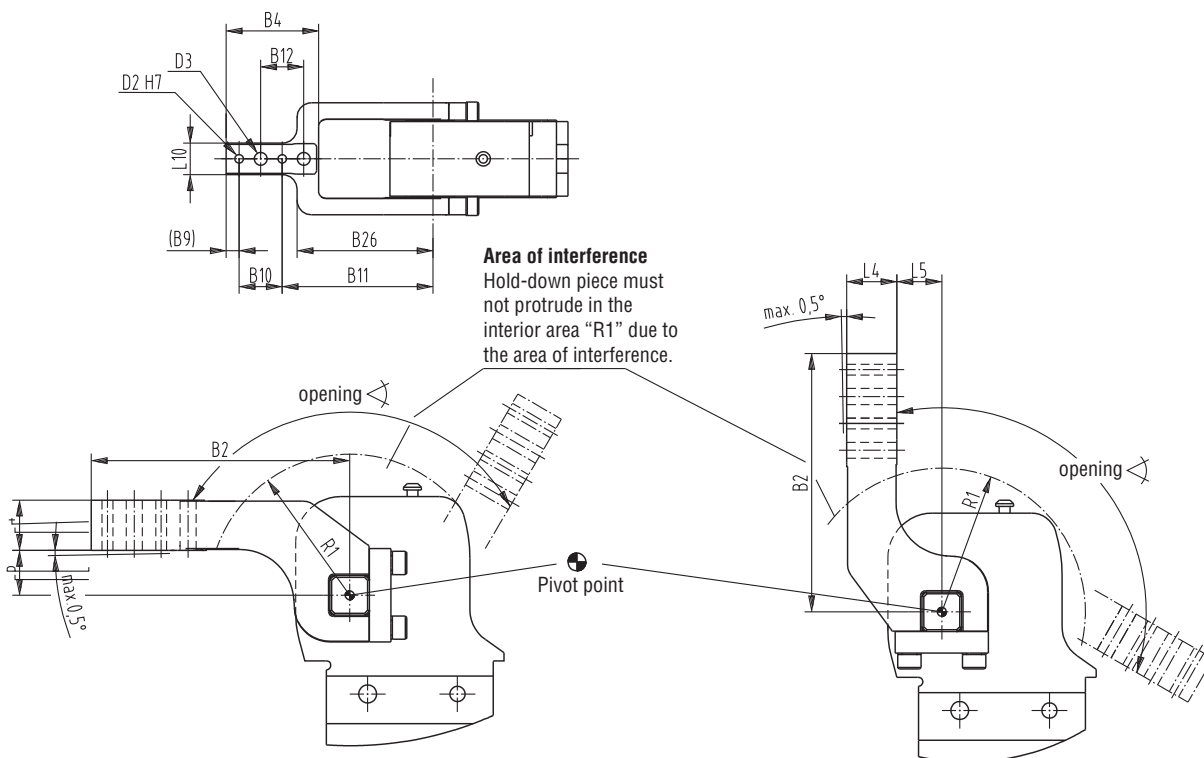

Series **52H05-6** Clamping Arm Variants

Clamping arm design

Lateral / Left

Lateral / Right

Lateral / Both Sides

Clamping position

Horizontal or Vertical

Horizontal or Vertical

Horizontal or Vertical



Lateral clamping arm, horizontal clamping position

Technical data (lateral clamping arms)

Model	Order no. for set of lateral clamping arms	Opening angle for clamping position		Weight Kg	B2	B4	B9	B10	B11	B12	B22	D2	D3	L4	L5	L10	R1	R2
		Horz.	Vert.															
52H05-6	8JG-080-1-01	120°	120°	0,9	144	74	9	30	105	30	10	6	9	28	15	20	80	28
	8S631-25-144	120°	120°	1	144	74	9	30	105	30	10	6	9	28	25	20	80	28
	8S631-75-204	120°	120°	1,5	204	78	9	30	165	30	10	6	9	30	75	20	80	28

Lateral clamping arms for **52H05-6**

Horizontal clamping arm position

Vertical clamping arm position

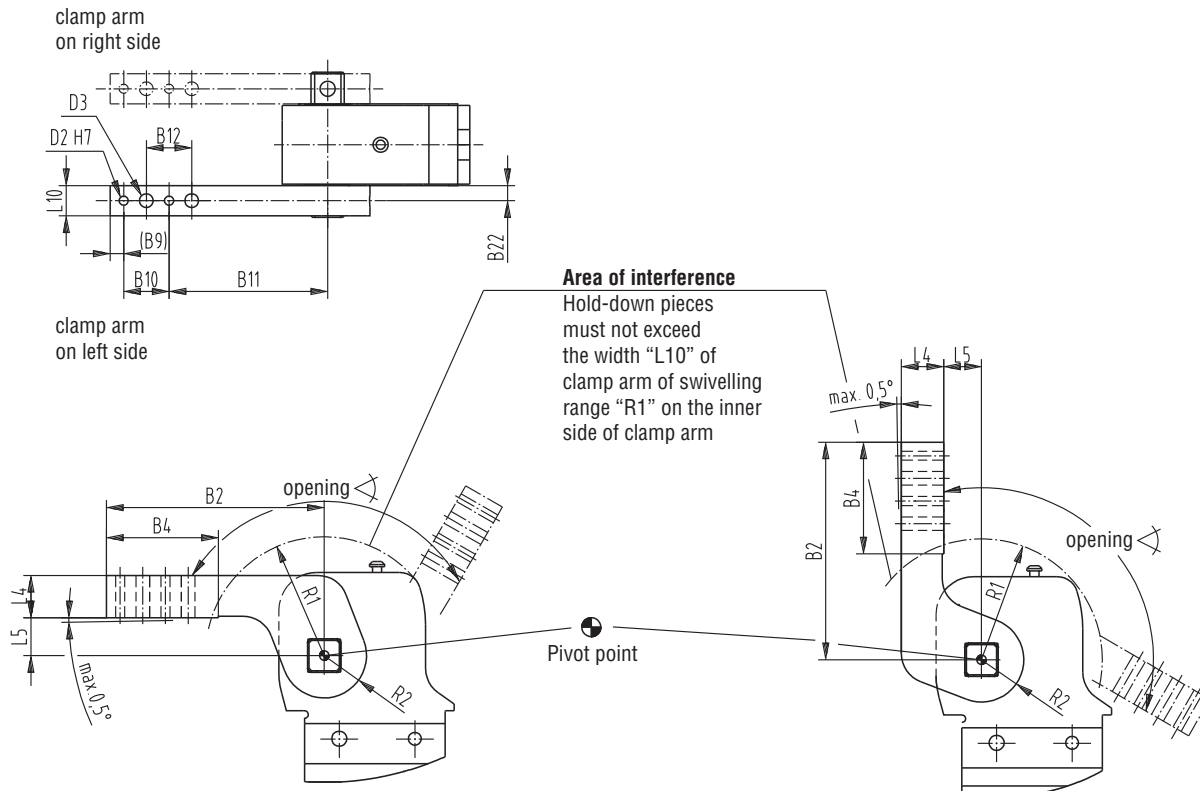

Series **52H05-6** Clamping Arm Variants

Clamping arm design

U-type clamping arm, Left

U-type clamping arm, Right

Clamping position

Horizontal or Vertical

Horizontal or Vertical

U-type clamping arm, left,
horizontal clamping position



U-type clamping arm, right,
horizontal clamping position



Technical data (U-type clamping arms, left and right)

Order no. for set of U-type central clamping arms for 52H05-6		Max. opening angle for clamping position		Weight Kg	B2	B4	B9	B10	B11	B12	B26	D2	D3	L4	L5	L10	L13	R1
		Horz.	Vert.		±0,02	±0,2	±0,2	H7	∅	±0,1	-0,5° max.	±0,1						
8UL631-15-144	8UR631-15-144	120°	105°	1,1	144	64.3	9	30	105	30	95	6	9	28	15	20	37	80
8UL631-25-144	8UR631-25-144	120°	120°	1,1	144	64.3	9	30	105	30	95	6	9	28	25	20	37	80
8UL631-45-144	8UR631-45-144	120°	120°	1,3	144	64.3	9	30	105	30	95	6	9	28	45	20	37	80
8UL631-75-204	8UR631-75-204	120°	120°	1,7	204	82	9	30	165	30	107	6	9	30	75	20	37	80

Lateral U-type clamping arms for **52H05-6**

Horizontal clamping arm position

Vertical clamping arm position

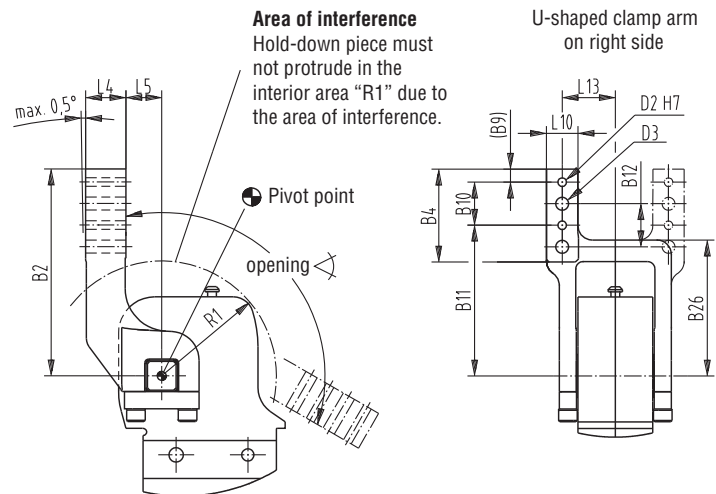
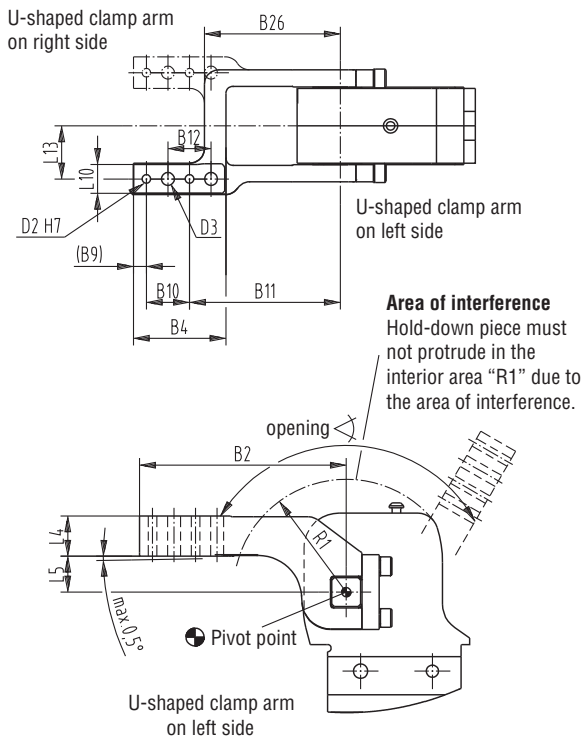

Specification			Order no. for set 52H05-6	Comment	
Clamping arm variant	Fulcrum Distance	Clamping Position			
U-central	15	horizontal / vertical	8UM631-15-144	sets of U-type clamping arms consist of clamping arm, links and screws	
U-central	25	horizontal / vertical	8UM631-15-144		
U-central	45	horizontal / vertical	8UM631-45-144		
U-central	75	horizontal / vertical	8UM631-75-204		
U-left	15	horizontal	8UL631-15-144		
U-left	25	horizontal	8UL631-25-144		
U-left	45	horizontal	8UL631-45-144		
U-left	75	horizontal	8UL631-75-204		
U-left	15	vertical	8UR631-15-144		
U-left	25	vertical	8UR631-25-144		
U-left	45	vertical	8UR631-45-144		
U-left	75	vertical	8UR631-75-204		
U-right	15	horizontal	8UR631-15-144		
U-right	25	horizontal	8UR631-25-144		
U-right	45	horizontal	8UR631-45-144		
U-right	75	horizontal	8UR631-75-204		
U-right	15	vertical	8UL631-15-144		
U-right	25	vertical	8UL631-25-144		
U-right	45	vertical	8UL631-45-144		
U-right	75	vertical	8UL631-75-204		
Lateral right/left	15	horizontal / vertical	8JG-080-1-01	sets of lateral clamping arms consist of clamping arm & set screws	
Lateral right/left	25	horizontal / vertical	8S631-25-144		
Lateral right/left	75	horizontal / vertical	8S631-75-204		
Lateral both sides				you need 2 sets of lateral clamping arms	
Connector cable (1 connector socket & 5m cable)					
Connector socket M12x1 Straight, 5-pin				8EL-002-1	
Connector socket M12x1 Angular, 4-pin				8EL-003-1	
Two hand operating for hold open device				82ZB-032-2	Hold open device

Shims for Clamping arm		Model no	A1	A2	D2	D3	B9	B10	B12	L10	
		82ZB-SH5001		0,1							
		82ZB-SH5002		0,2							
		82ZB-SH5005	65	0,5	6,5	9	10	30	30	16	
		82ZB-SH5010		1,0							
		82ZB-SH5020		2,0							
		82ZB-SH5050		5,0							

Series **52H05-6** Accessories

Wiring diagram of electrical sensing system

Sensing system immune to interference from d.c. arc welding and a.c. arc welding

Pin assignment

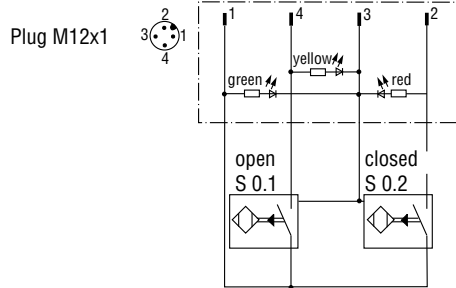
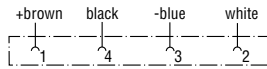

Inductive design:

- A1 Connector plug M12x1, fixed (Turck)
- A2 Connector plug M12x1, fixed (Pepperl & Fuchs)

Series **56H40-2** Product Overview

Features:

- Compact design
- Low weight
- High accuracy of positioning due to twin piston rod guide
- Lateral and front-face mounting areas
- Length of stroke: 20mm, 40mm or 60mm available
- Various mounting bases for centring pin incl. precision bore holes and grooves or integrated thread
- Inductive sensing module with LED display
- Toggle Lock in extracted position prevents unattended retracting of piston rod

Application:

Accurate positioning of sheet metal parts in welding equipment and handling systems. At the end of the welding process, the pins are retracted from the pin holes. The component can thus be easily removed from the jig.

Key areas of application:

Automotive manufacturing, sheet processing industry, jig and general mechanical engineering.



56H40-202C800A
stroke 40 mm and sensing kit



56H40-202C800C
stroke 60 mm and sensing kit

Order no. Example: **56H40-2 02 C8 00 A K** — **K = ceramic coating plunger**

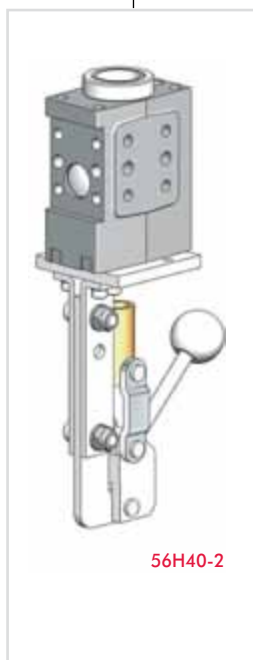

Base Model

02 = Piston rod adapter
Ø16 mm, Cross groove

05 = Piston rod adapter
Ø 10 mm, Cross groove

Piston rod adapter

L4 (stroke 20/40) =
without sensing system cover plate
86P0-200L4

L6 (stroke 60) =
without sensing system cover plate
86P0-200L6

C8 =
with sensing system
86P0-200C8
(for stroke 20/40)
86P0-200C8006
(for stroke 60)
Fabr. Turck

D8 =
with sensing system
86P0-200D8
(for stroke 20 / 40)
86P0-200D8006
(for stroke 60)
P&F

C6 = with sensing system
86P0-200C6
(for stroke 20 / 40)
86P0-200C6006
(for stroke 60)

Inductive sensing system

00 = without accessories

E1 =
(only with A or B)
E2 = (only with C)
External guide

F1 =
Bellow
82ZB-013-3
(strokes 20 or 40)

G1 =
Bellow/adaptor
(strokes 20 or 40)

H1 =
Adaptor
86P0-20000H1

J1 =
(only with A or B)
External guide/
Adaptor
86P0-20000J1

Accessories

A = 40 mm stroke
C = 60 mm stroke
Anti - twist device
low accuracy
8CE-231-1

B = 20 mm stroke
Anti - twist device
low accuracy
8MF-071-1

2 = 20 mm stroke
Anti - twist device
86P0-20000002

4 = 40 mm stroke
Anti - twist device
86P0-20000004

6 = 60 mm stroke
Anti - twist device
86P0-20000006

Stroke

Series 56H40-2 Clamp Dimensions

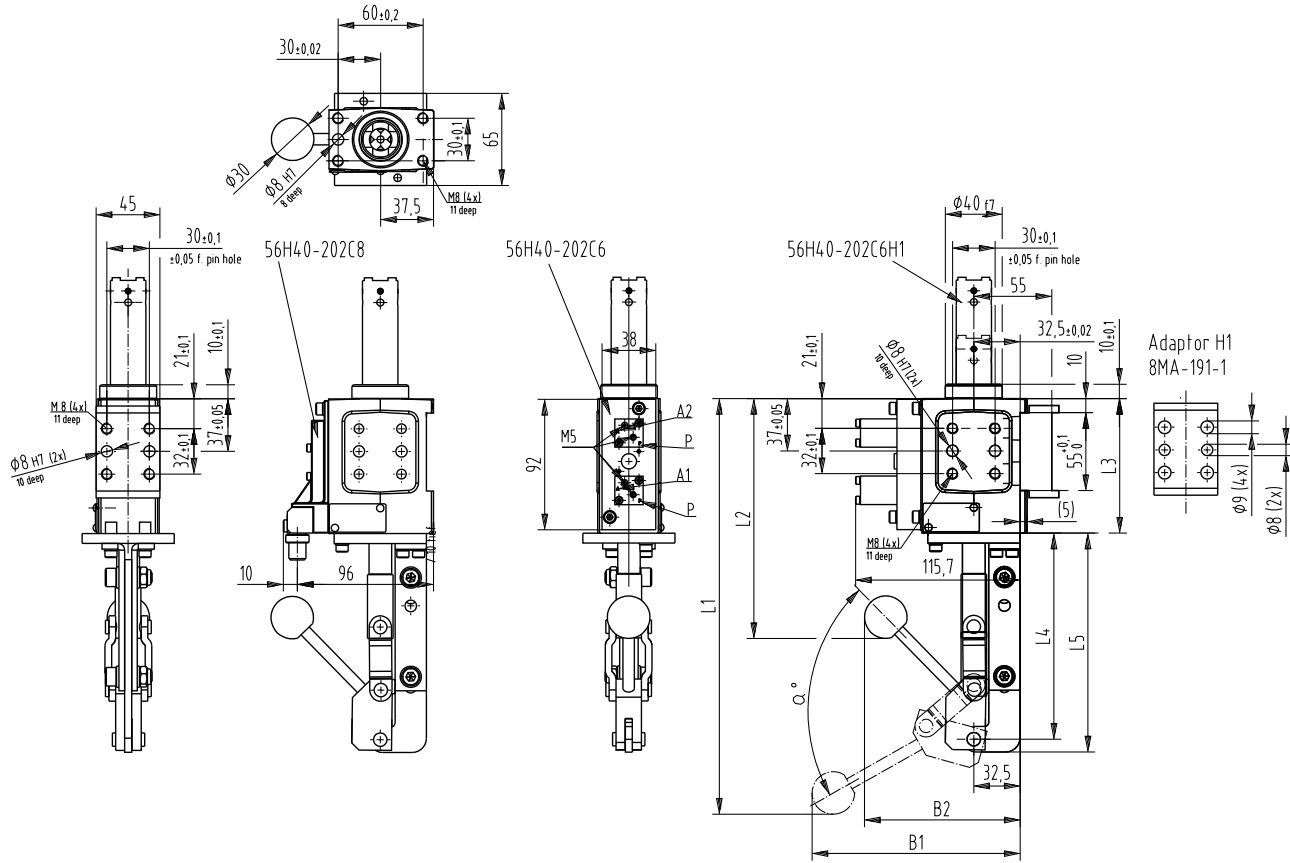

Pneumatic Position Control System:
 P = Compressed air connection for position control system
 A1 = Control connection for retracted position
 A2 = Control connection for extracted position

Series 56H40-2 Technical Information

Model no.	Stroke +2 [mm]	Weight ~ [kg]	B1	B2	L1	L2	L3	L4	L5	W ~
56H40-2..2	20	2,0	182	140	312	138	95	166	175	40
56H40-2..4	40	2,0	182	140	312	138	95	146	155	75
56H40-2..6	60	2,5	133	157	385	182	115	146	155	90
56H40-2..B	20	2,0	182	140	312	138	95	166	175	40
56H40-2..A	40	2,0	182	140	312	138	95	146	155	75
56H40-2..C	60	2,5	133	157	385	182	115	146	155	90

Series **56H40-2** Standard Clamp Dimensions

Pison Rod Model **-202** Detail mounting base $\varnothing 16$ mm for **56H40-2** (Also valid for electric pin package 96M-1002.)

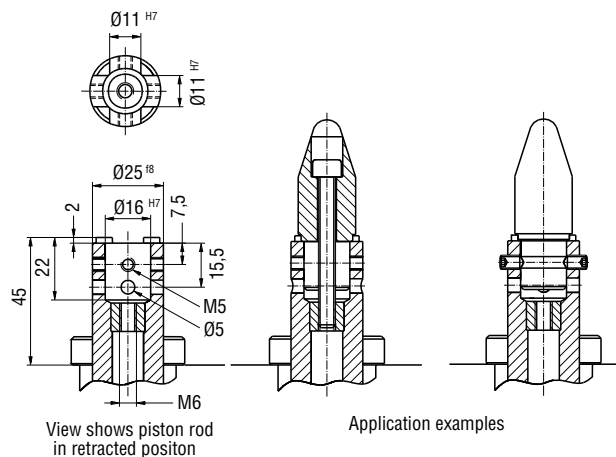

Pison Rod Model **-205** Detail mounting base $\varnothing 10$ mm for **56H40-2** (Also valid for electric pin package 96M-1005.)

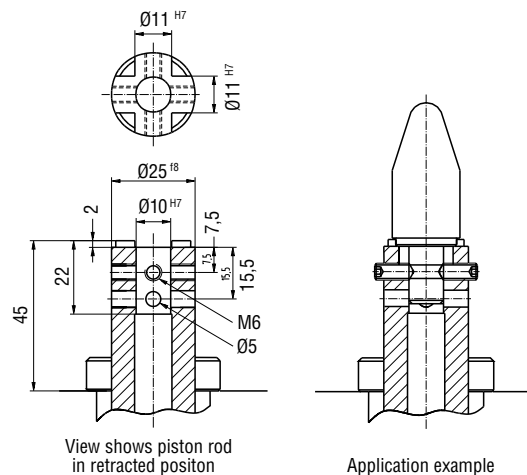

Max deflection for centering pin for **56H40-2**

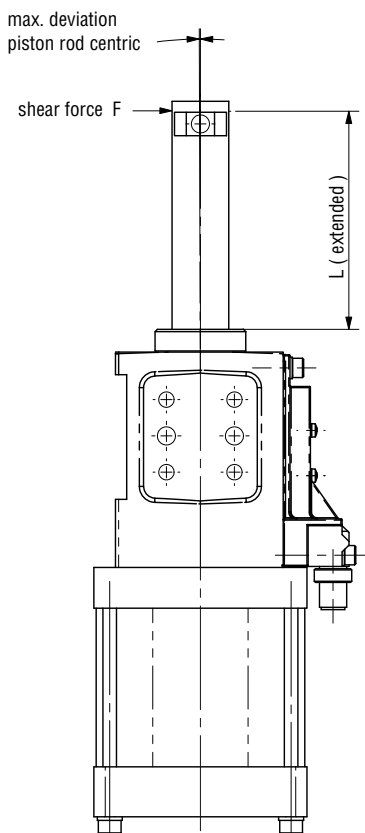

Model no.	Sheer force N [lbs]	L mm [in]	Stroke mm [in]	Deviation mm [in]
56H40-2...B / 2	200 [45]	52 [2.0]	20 [0.08]	0,06 [0.002]
56H40-2...A / 4	200 [45]	70 [2.8]	40 [1.60]	0,09 [0.004]
56H40-2...C / 6	200 [45]	90 [3.5]	60 [2.40]	0,12 [0.007]

Caution: Generally we recommend using an external guide when the transverse force is more than 200 N [45 lbs]. Also independently of the stroke, less transverse forces, when the overall height $L_2 > 120$ mm [4.7 in] ($L_2 =$ extended piston rod plus centering pin).

Series **56H40-202C8E1A** Pin packages with external guide (Accessory)

Example application of an off-center centering pin for **56H40-2**

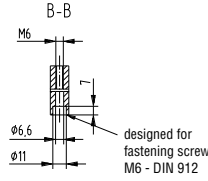
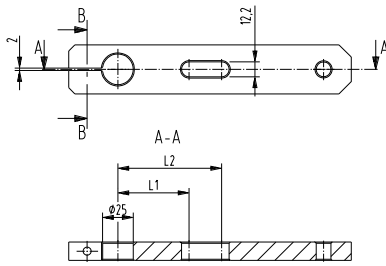

The component shown in this example is to be made by the customer

Model no.	L1	L2
86P40/60-2...E1	58	62
86P40/60-2...E2		
86P40/60-2...J1*	80,5	84,5

* J1 is not available with stroke 60 mm.



Internal anti-rotation device

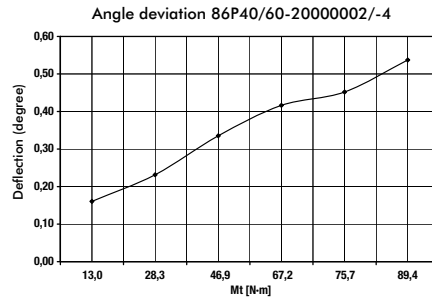
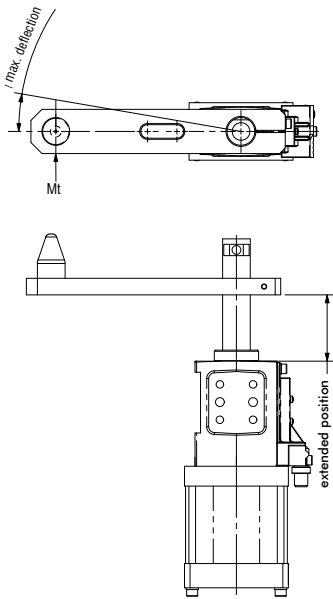

Caution: Generally we recommend using an external guide when the transverse force is more than 200 N [45 lbs] Also independently of the stroke, less transverse forces, when the overall height L2 > 120 mm [4.7 in] (L2 = extended piston rod plus centering pin).

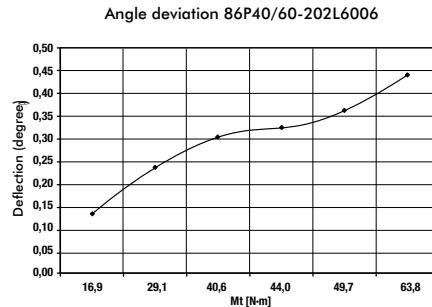

External guide **82ZB-009-2, 82ZB-010-2, 82ZB-090-1**

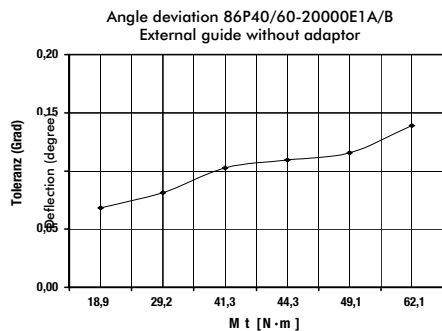
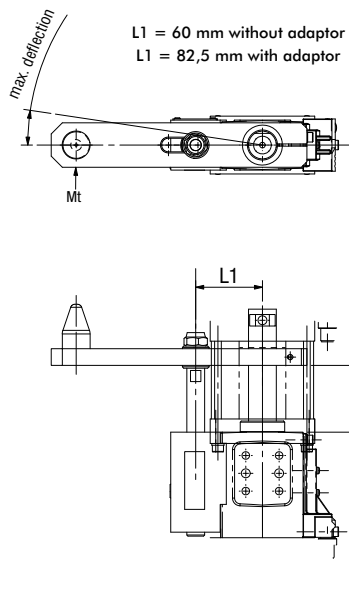

Caution: Generally we recommend using an external guide when the transverse force is more than 200 N [45 lbs] Also independently of the stroke, less transverse forces, when the overall height L2 > 120 mm [4.7 in] (L2 = extended piston rod plus centering pin).

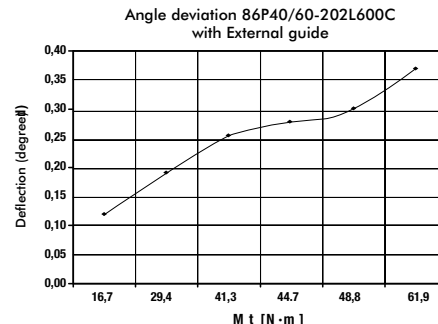
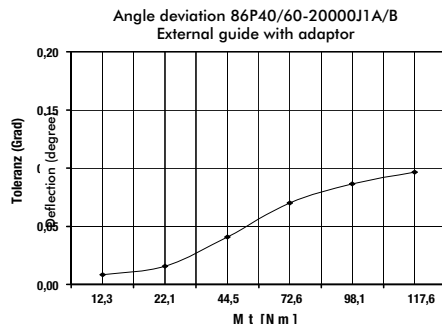



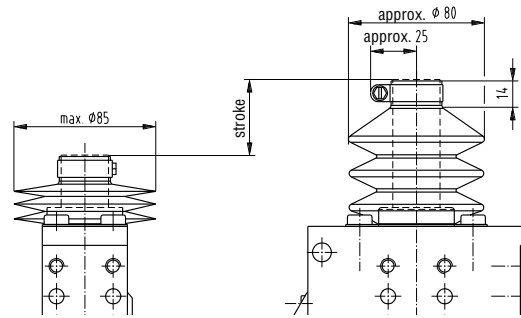

Piston rod cover 82ZB-013-3 (accessory part)

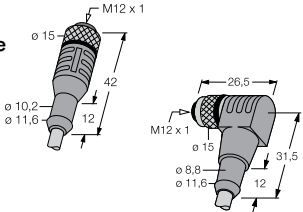

Accessories

Order No.	Specification	Comment
82ZB-009-2 (only with A+B) 82ZB-090 (with C)	External guide 	use without bellows only
82ZB-013-3 (only stroke 20 0.40)	Bellows 	Use without external guide only
8EL-002-1 8EL-003-1	Connecting cable (1 connector socket & 5 m cable) Connector socket M12x1 straight, 5-pin Connector socket M12x1 angular, 4-pin 	

Wiring diagram of electrical sensing system
Sensing system immune to interference from d.c. arc welding and a.c. arc welding

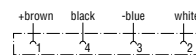

Inductive design:

- C8 Connector plug M12x1, fixed (Turck)
- D8 Connector plug M12x1, fixed (Pepperl & Fuchs)

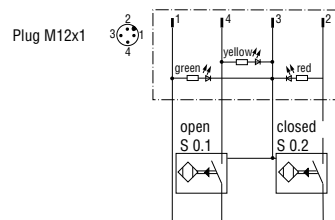

Major spare parts

Order no. for	Specification
56H40-2	
86PO-200C8 86PO-200D8	End position sensing system C8 connector plug M12x1, fixed (Turck) D8 connector plug M12x1, fixed (Pepperl & Fuchs)
82ZB-046-1	Hand lever set