









	Series	Section Page	Cylinder Bore [inch] mm						Clamping Force @ 6bar [87psi] N [lbf.]						Stroke mm [inch]		
			[0.75 to 1.00] 19 to 25	[1.18 to 1.26] 30 to 32	[1.50 to 1.57] 38 to 40	[1.97] 50	[2.48] 63	[20 to 27] 90 to 120	[40 to 52] 180 to 230	[63 to 72] 280 to 320	[90 to 105] 400 to 470	[112 to 117] 500 to 520	[166 to 195] 740 to 870	[260 to 300] 1170 to 1330	[0.31 to 0.39] 8 to 10	[0.47 to 0.63] 12 to 16	[0.78 to 0.98] 20 to 25
9500 	9522	11.3	■						■							■	
	9530	11.3		■						■							■
	9540	11.3			■						■						■
89R 	89R20-010-2	11.5	■						■							■	
	89R32-010-2	11.5		■						■						■	
	89R40-010-2	11.5			■						■					■	
	89R40-025-2	11.5			■						■					■	
	89R50-025-2	11.5				■						■				■	
	89R63-025-2	11.5					■						■			■	
89B 	89B20-010-1	11.7	■						■							■	
	89B30-010-1	11.7		■						■						■	
	89B40-010-1	11.7			■						■					■	
	89B50-025-1	11.7				■						■				■	
	89B63-008-1	11.7					■						■			■	
8100, 8300 	8115	11.7	■						■							■	
	8116	11.7	■							■						■	
	8315	11.7			■						■					■	
	8316	11.7			■						■					■	
89E 	89E20-010-1	11.11	■						■							■	
	89E30-010-1	11.11		■						■						■	
	89E40-010-1	11.11			■						■					■	
	89E50-025-1	11.11				■						■				■	
	89E63-008-1	11.11					■						■			■	



	Series	Section Page	Cylinder Bore [inch] mm					Clamping Force @ 6bar [87psi] N [lbf.]					Stroke mm [inch]			
			[0.75 to 1.00] 19 to 25	[1.18 to 1.26] 30 to 32	[1.50 to 1.57] 38 to 40	[1.97] 50	[2.48] 63	[20 to 27] 90 to 120	[40 to 52] 180 to 230	[63 to 72] 280 to 320	[90 to 105] 400 to 470	[112 to 117] 500 to 520	[166 to 195] 740 to 870	[260 to 300] 1170 to 1330	[0.31 to 0.39] 8 to 10	[0.47 to 0.63] 12 to 16
8000, 8200, 8400 	8015	11.11	■					■						■		
	8016	11.11	■					■						■		
	8215	11.11			■				■						■	
	8216	11.11			■				■						■	
	8415	11.11		■					■						■	
	8416	11.11		■					■						■	
035-1 	035-125-190	11.15	■					■						■		
	035-125-290	11.15	■					■						■		
	035-132-190	11.15		■					■						■	
	035-132-290	11.15		■					■						■	
	035-140-190	11.15			■					■					■	
	035-140-290	11.15			■					■					■	
	035-150-190	11.15				■					■				■	
	035-150-290	11.15				■					■				■	
035-2 	035-225-190	11.15	■					■						■		
	035-225-290	11.15	■					■						■		
	035-232-190	11.15		■					■						■	
	035-232-290	11.15		■					■						■	
	035-240-190	11.15			■					■					■	
	035-240-290	11.15			■					■					■	
	035-250-190	11.15				■					■				■	
	035-250-290	11.15				■					■				■	

Series 9500 Product Overview

Features:

- No linear travel during rotation
- Rod cover to protect rod throughout the entire stroke
- Versatile arm connection
- Fixed orifice porting does not require external flow controls

Applications:

- Assembly
- Welding
- Light machining

Also Available:

- See page 12.2 for clamping arms
- See page 13.1 for sensing options

Covered under one year or more U.S./International Patents

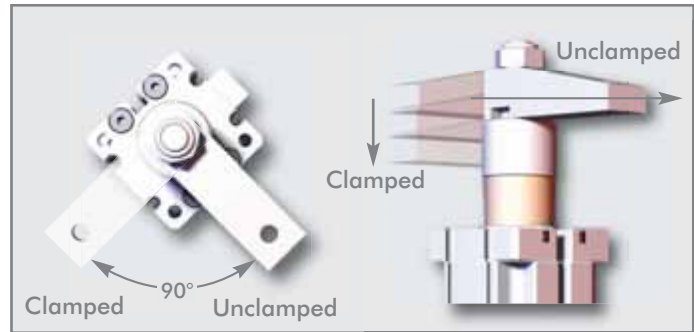

Shown with optional clamping arm.

Series 9500 Technical Information

Model	Total Stroke mm[in]	Swing Direction	Weight kg[lb.]	Effective Piston Area for Clamping cm ² [in. ²]	Clamp Volume cm ³ [in. ³]	Unclamp Volume cm ³ [in. ³]	Rod Force @ 6bar[87PSI] N[lbf.]	Seal Kit
9522L	[0.50] 13	LH	[0.94] 0,43	[0.61] 3,90	[0.61] 10	[0.76] 12,5	[53] 235	952290
9522R		RH						
9530L	[0.79] 20	LH	[1.38] 0,63	[1.03] 6,65	[1.33] 21,8	[1.58] 25,9	[90] 400	953090
9530GL								
9530R		RH						
9530GR								
9540L	[0.79] 20	LH	[2.13] 0,97	[1.84] 11,87	[2.36] 38,8	[2.69] 44	[160] 711	954090
9540GL								
9540R		RH						
9540GR								

Rotation Angle: 90°±5°

Repeatability: ±1°

Operating Pressure Range: 3bar[40psig] to 8bar[120psig]

Maximum Operating Temperature: 60°C[140°F]

Series 9500 Standard Clamp Dimensions, Clamping Forces

Series 9522 Clamping Force

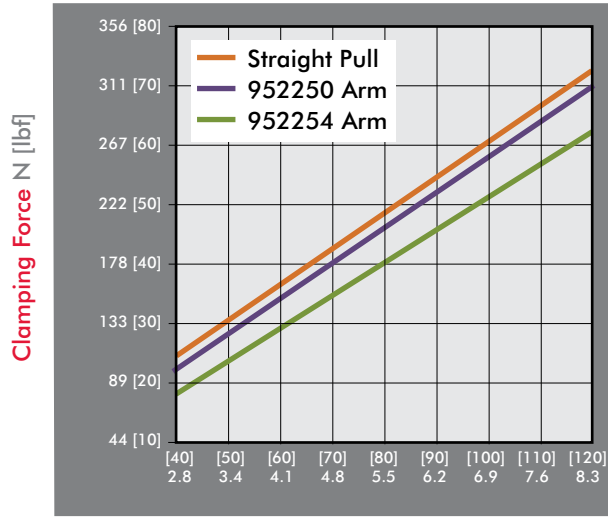

Inlet Pressure bar [PSI]

Series 9540 Clamping Force

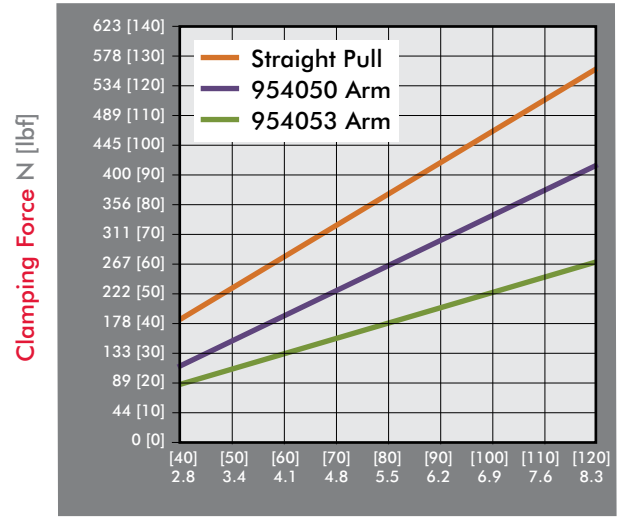

Inlet Pressure bar [PSI]

Series 9530 Clamping Force

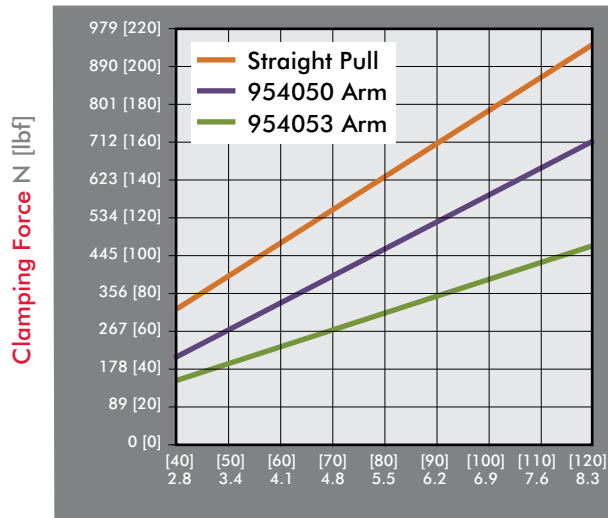

Inlet Pressure bar [PSI]

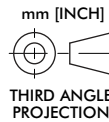
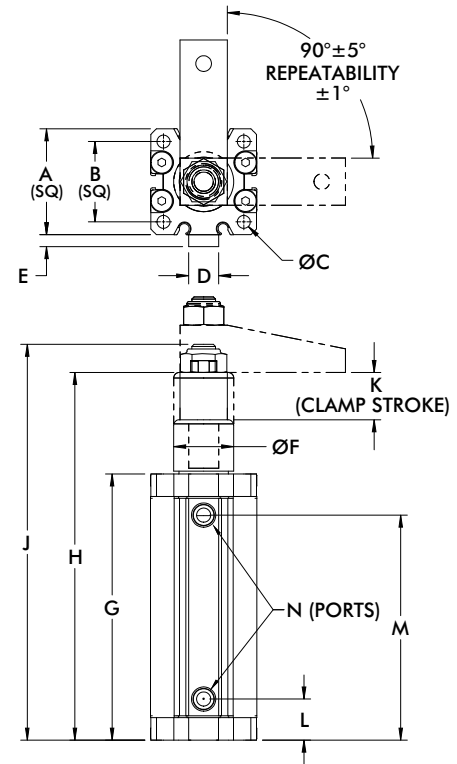

Model	A	B	C	D	E	F	G	H	J	K	L	M	N
9522	[1.42] 36	[1.00] 25,4		--	--	[0.88] 22	[4.00] 102	[4.56] 116	[5.43] 138	[0.50] 13	[0.54] 14	[3.13] 80	M5
9530	[1.76] 44,7	[1.34] 34	[0.22] 5,5	[0.50] 12,7	[0.20] 5,1	[1.00] 25,4	[4.44] 112,7	[6.13] 155,7	[6.59] 167,3	[0.79] 20	[0.68] 17,4	[3.75] 95,3	1/8NPT
9530G													
9540	[2.05] 52	[1.57] 40		[0.63] 16	[0.35] 9	[1.14] 29	[4.78] 121,4	[6.50] 165	[6.94] 176,2		[0.84] 21,3	[3.97] 100,8	1/8NPT
9540G													G-1/8

Series 89R Product Overview

Features:

- Swing direction is field adjustable between left, right, or straight. (20mm not linear adjustable)
- Switch ready for Ø4mm or 6.5mmX5mm sensors
- Lightweight and robust, designed for several million cycles
- Clamp arm sold separately

Applications:

- Assembly
- Welding
- Light machining

Also Available:

See page 12.2 - 12.5 for clamping arms and mounting accessories
See page 13.1 for sensing options

89R



Note:
Switches are optional. To order with (2) 8EA-109-1 switches, add **A** to the end of the model. Ex. 89R32-010-2**A**

Series 89R Technical Information

Model	Total Stroke mm[in]	Travel During Rotation mm[in]	Vertical Clamp Stroke mm[in]	Bore Size mm[in]	Clamp Volume cm ³ [in. ³]	Unclamp Volume cm ³ [in. ³]	Clamping Force @ 6bar[87PSI] N[lbf.]†	Weight kg[lb.]	Seal Kit
89R20-010-2	[0.83] 21	[0.43] 11		[0.79] 20	[0.03] 4,9	[0.40] 6,6	[22] 96	[0.66] 0,30	89R20-00
89R32-010-2	[1.10] 28	[0.61] 18	[0.39] 10	[1.26] 32	[1.18] 19,4	[1.37] 22,5	[67] 300	[1.32] 0,60	89R32-00
89R40-010-2	[1.24] 31,5	[0.85] 21,5		[1.57] 40	[2.03] 33,3	[2.42] 39,6	[103] 456	[2.09] 0,95	89R40-00
89R40-025-2	[1.83] 46,5				[3.00] 49,1	[3.57] 58,4		[2.43] 1,10	
89R50-025-2	[2.05] 52	[1.06] 27	[0.98] 25	[1.97] 50	[5.42] 88,9	[6.23] 102,1	[167] 744	[3.97] 1,80	89R50-00
89R63-025-2	[2.30] 58,5	[1.32] 33,5		[2.48] 63	[11.13] 164	[11.13] 182,4	[263] 1170	[6.17] 2,80	89R63-00

† with standard clamping arm

Rotation Angle: 90°±5°

Operating Pressure Range: 2bar[30psig] to 10bar[145psig]

Series 89R Standard Clamp Dimensions, Clamping Forces

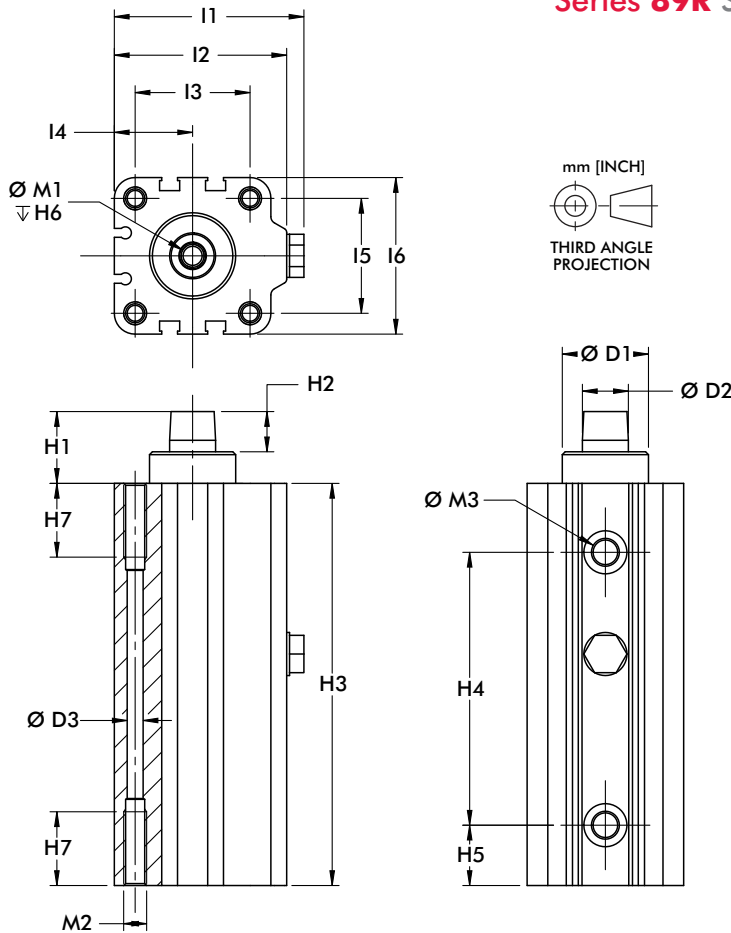

Series 89R Clamping Force (w/ standard clamping arm)

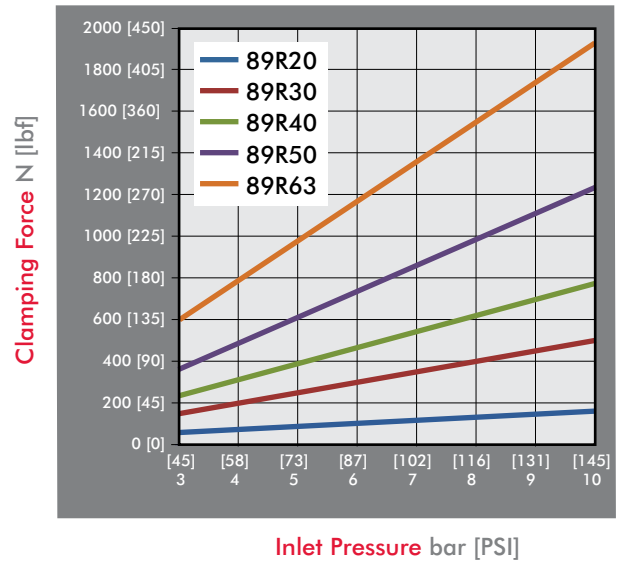

Model	ØD1	ØD2	ØD3	H1	H2	H3	H4	H5	H6	H7	L1	L2
89R20-010-2	[0.71] 18	[0.39] 10	[0.18] 4,6	[0.78] 19,8	[0.32] 8	[4.15] 105,5	[2.60] 66	[0.52] 13,2	[0.59] 15	[0.55] 14	[1.56] 39,5	[1.38] 35
89R32-010-2	[0.87] 22	[0.47] 12		[0.93] 23,7		[4.92] 125	[3.27] 83	[0.69] 17,5		[0.63] 16	[2.36] 60	[2.13] 54
89R40-010-2	[1.18] 30	[0.63] 16	[0.22] 5,5	[0.98] 25	[0.43] 11	[5.51] 140	[3.74] 95	[0.83] 21	[0.67] 17		[2.60] 66	[2.36] 60
89R40-025-2						[6.69] 170	[4.92] 125			[0.98] 25		
89R50-025-2	[1.57] 40	[0.71] 18	[0.29] 7,4	[1.24] 31,4		[7.70] 195,5	[5.39] 137	[1.05] 26,7			[3.09] 78,5	[2.85] 72,5
89R63-025-2	[1.77] 45	[0.78] 20	[0.37] 9,3	[1.30] 33	[0.59] 15	[8.33] 211,5	[6.08] 154,5	[1.04] 26,5			[3.74] 95	[3.46] 88

Model	L3	L4	L5	L6	M1	M2	M3
89R20-010-2	[0.87] 22	[0.63] 16	[0.87] 22	[1.26] 32	M5	M6	M5
89R32-010-2	[1.42] 36	[0.94] 24	[1.26] 32	[1.77] 45	M6		
89R40-010-2	[1.57] 40	[1.07] 27,3	[1.57] 40	[2.15] 54,5	M8	M8	G-1/8
89R40-025-2							
89R50-025-2	[1.57] 40	[1.28] 32,5	[2.56] 65		M10	M10	
89R63-025-2	[2.44] 62	[1.57] 40	[3.15] 80		M10	M12	G-1/4

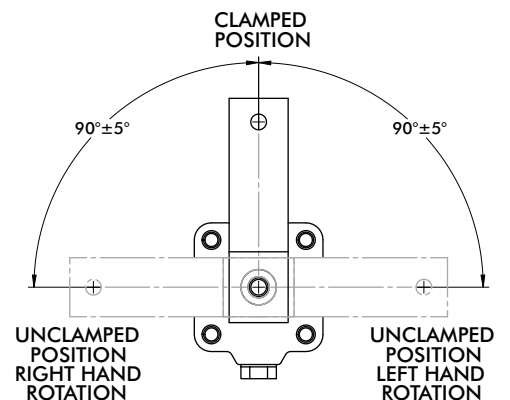

Series 89B, 8100, 8300 Product Overview

Features:

- Proven, reliable designs
- Lightweight and robust, designed for several million cycles
- Can be mounted from the side or top

Applications:

- Assembly
- Welding
- Light machining

Also Available:

See page 12.2 - 12.5 for clamping arms and mounting accessories
See page 13.1 for sensing options

Series 89B ■



Available in 20, 30, 40, 50, and 63mm bore sizes.
Switches are optional. To order with (2) 8EA-109-1 switches, add **A** to the end of the model. Ex. 89B30-010-1**RA**
Clamping arm sold separately, see page 12.2-12.5

Series 8100, 8300 ▲



Switches are optional. To order with (2) 810169 switches, add **A** to the end of the model. Ex. 8115-A.
Supplied with clamping arm and spindle.
To order without clamping arm add **-LA** to the end of the model. Ex. 8115-**LA**

Series 89B, 8100, 8300 Technical Information

Model	Swing	Total Stroke mm[in]	Travel During Rotation mm[in]	Vertical Clamp Stroke mm[in]	Bore Size mm[in]	Clamp Volume cm ³ [in. ³]	Unclamp Volume cm ³ [in. ³]	Clamping Force @ 6bar[87PSI] N[lbf.]†	Weight kg[lb.]	Seal Kit
■ 89B20-010-1R	R	[0.79]	[0.39]		[0.79]	[0.29]	[0.38]	[22]	[1.70]	8940-3-00
■ 89B20-010-1L	L	20	10		20	4,71	6,28	97	0,77	
■ 89B30-010-1R	R	[0.83]	[0.43]	[0.39]	[1.18]	[0.76]	[0.91]	[63]	[2.43]	8945-3-00
■ 89B30-010-1L	L	21	11	10	30	12,47	14,85	280	1,10	
■ 89B40-010-1R	R	[0.94]	[0.55]		[1.57]	[1.55]	[1.84]	[103]	[3.26]	8950-3-00
■ 89B40-010-1L	L	24	14		40	25,34	30,16	460	1,48	
■ 89B50-025-1R	R	[1.57]	[0.59]	[0.98]	[1.97]	[4.17]	[4.79]	[194]	[5.73]	8952-3-00
■ 89B50-025-1L	L	40	15	25	50	68,37	78,55	865	2,6	
■ 89B63-008-1R	R	[1.02]	[0.71]	[0.32]	[2.48]	[4.45]	[4.95]	[298]	[6.24]	8955-3-00
■ 89B63-008-1L	L	26	18	8	63	72,89	81,06	1330	2,83	
▲ 8115	R	[0.85]	[0.47]	[0.38]	[0.75]	[0.25]	[0.38]	[25]	[0.68]	801560
▲ 8116	L	21,5	11,8	9,7	19,1	4,1	6,23	110	0,31	
▲ 8315	R	[1.25]	[0.75]	[0.50]	[1.50]	[2.01]	[2.26]	[89]	[2.00]	821560
▲ 8316	L	31,8	19,1	12,7	38,1	32,94	37,03	400	0,91	

† with standard clamping arm Preferred Market: ▲ NA/SA ■ Europe ● Global

Operating Pressure Range:

89B: 3bar [30psig] to 10bar [145psig] (89B20 8bar [116psig] max.)
8100, 8300: 3bar [30psig] to 9bar [130psig]

Series 89B Standard Clamp Dimensions

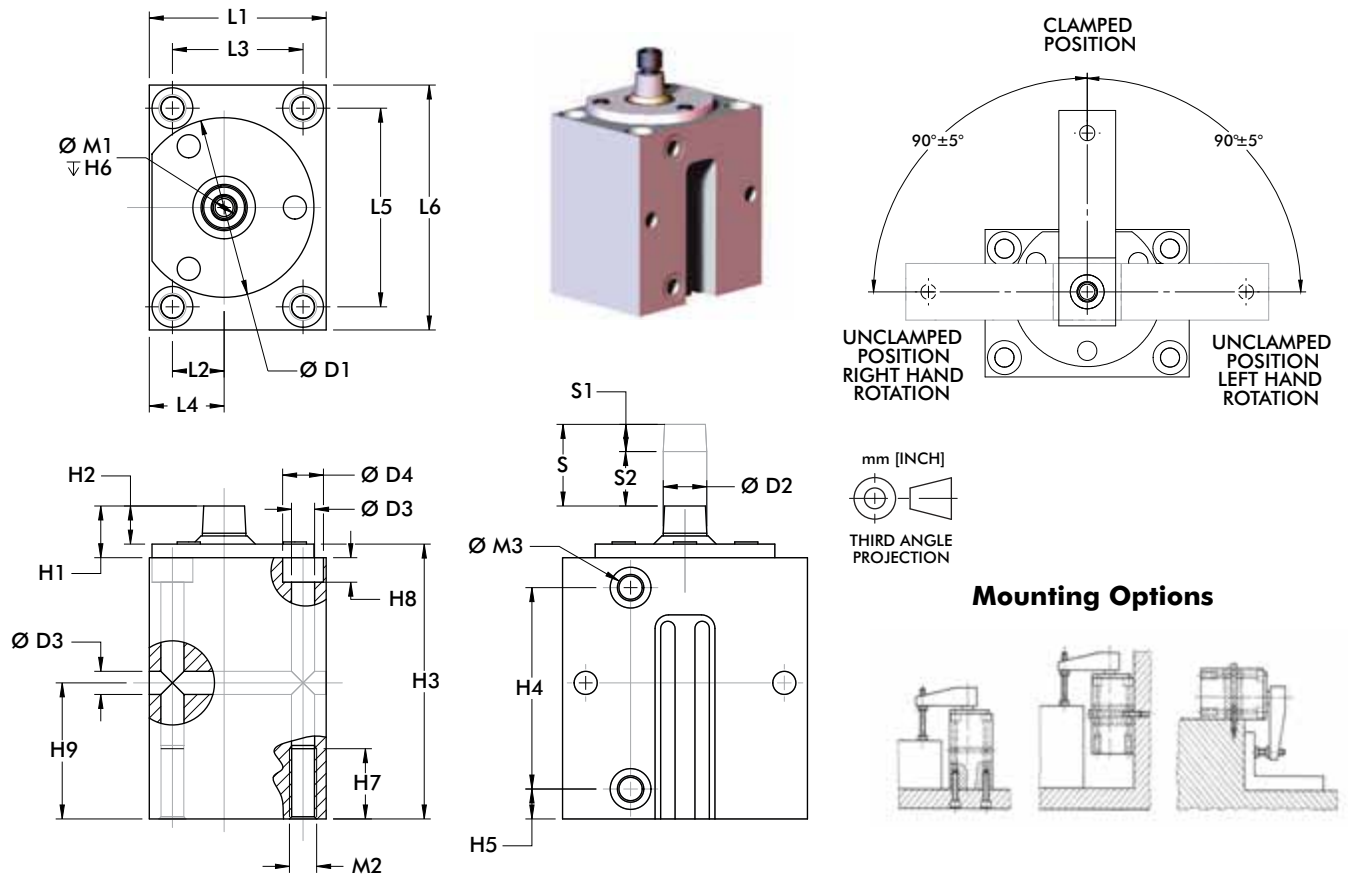

Mounting Options

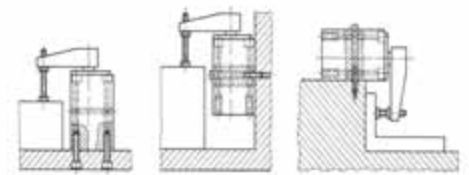

Model	ØD1	ØD2	ØD3	H1	H2	H3	H4	H5	H6	H7	L1	L2
89B20	[1.89] 48	[0.39] 10	[0.26] 6,6	[0.69] 17,5	[0.37] 9,5	[3.46] 88	[2.31] 58,7	[0.35] 9	[0.59] 15	[0.79] 20	[1.77] 45	[0.45] 11,5
89B32	[2.52] 64	[0.47] 12	[0.33]	[0.63] 16	[0.43] 11	[3.70] 94	[2.72] 69,2	[0.39] 10	[0.67] 17	[0.98]	[2.17] 55	[0.55] 14
89B40	[2.95] 75	[0.63] 16	8,5	[0.75] 19	[0.55] 14	[3.98] 101	[2.91] 74			25	[2.56] 65	[0.75] 19
89B50	[3.54] 90	[0.71] 18	[0.41]	[0.98] 25	[0.67] 17	[5.51] 140	[4.29] 109	[0.43] 11	[0.98] 25	[1.18]	[2.95] 75	[0.94] 24
89B63	[4.13] 105	[0.79] 20	10,5	[1.06] 27	[0.75] 19	[4.53] 115	[3.35] 85		[0.79] 20	30	[3.54] 90	[1.18] 30

Model	L3	L4	L5	L6	M1	M2	M3
89B20	[1.18] 30	[0.75] 19	[2.36] 60	[2.95] 75	M5	M8	M5
89B32	[1.50] 38	[0.89] 22,5	[2.68] 68	[3.35] 85	M6	M10	
89B40	[1.89] 48	[1.08] 27,5	[2.87] 73	[3.54] 90	M8		G-1/8
89B50	[2.17] 55	[1.34] 34	[3.54] 90	[4.33] 110		M12	
89B63	[2.76] 70	[1.57] 40	[3.94] 100	[4.72] 120	M10		G-1/4

Series 8100, 8300 Standard Clamp Dimensions

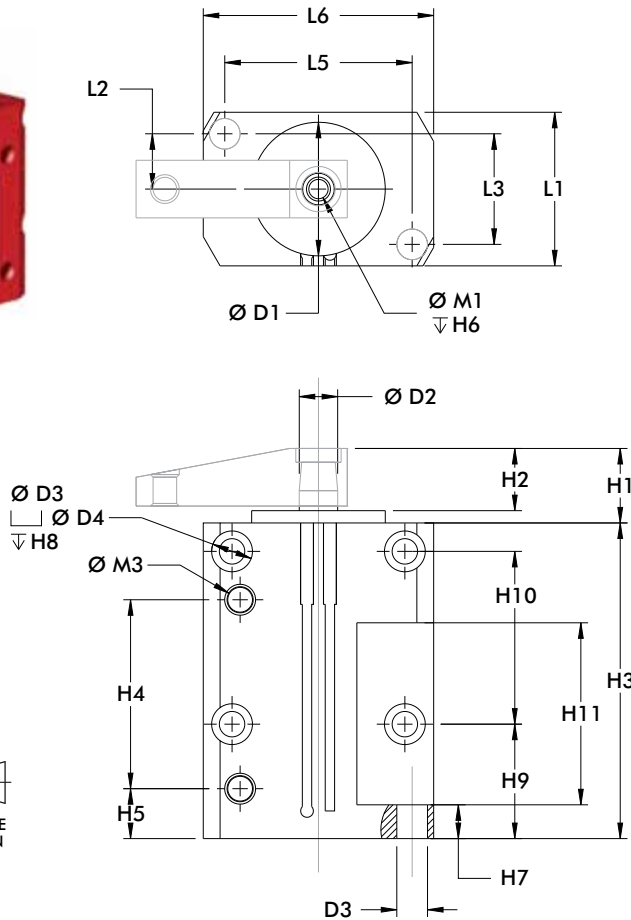

mm [INCH]
THIRD ANGLE PROJECTION

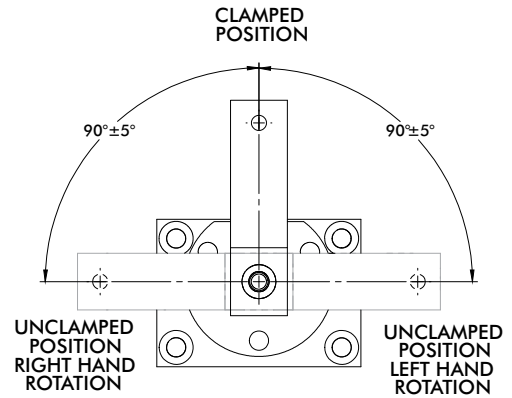

Mounting Options

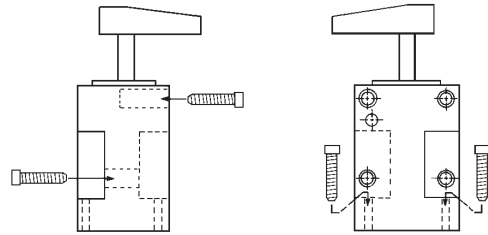

Model	ØD1	ØD2	ØD3	ØD4	H1	H2	H3	H4	H5	H6	H7	H8
8115	[1.23]	[0.44]	[0.20]	--	[0.53]	[0.41]	[3.37]	[1.45]	[0.35]	[0.75]	[0.25]	--
8116	31,2	11,2	5,1	--	13,5	10,4	85,6	36,8	8,9	19,1	6,4	--
8315	[1.74]	[0.50]	[0.33]	[0.53]	[0.97]	[0.81]	[4.11]	[2.46]	[0.65]	[0.67]	[0.44]	[1.00]
8316	44,2	12,7	8,4	13,5	24,6	20,6	104,4	62,5	16,5	17	11,2	25,4

Model	H9	H10	H11	L1	L2	L3	L5	L6	M1	M3
8115	[1.37]	[1.00]	[1.00]	[1.25]	[0.47]	[0.94]	[0.94]	[1.25]	¼-20	#10-32
8116	34,8	25,4	25,4	31,8	11,9	23,9	23,9	31,8		
8315	[1.49]	[2.25]	[2.37]	[2.00]	[0.72]	[1.44]	[2.44]	[3.00]	5/16/18	1/8 NPT
8316	37,9	57,2	60,2	50,8	18,3	36,6	62	76,2		

Series 89B, 8100, 8300 Clamping Forces

Series 89B Clamping Force
(w/ standard clamping arm)

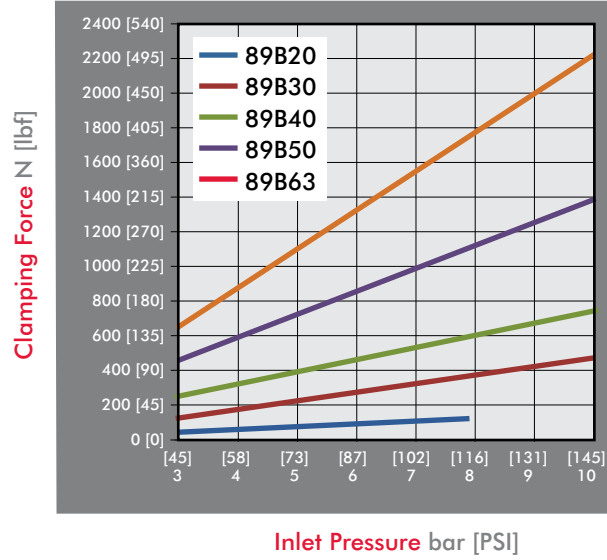
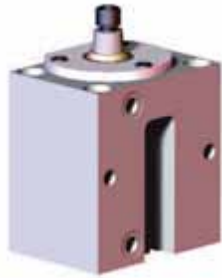

Series 8100, 8300 Clamping Force
(w/ standard clamping arm)

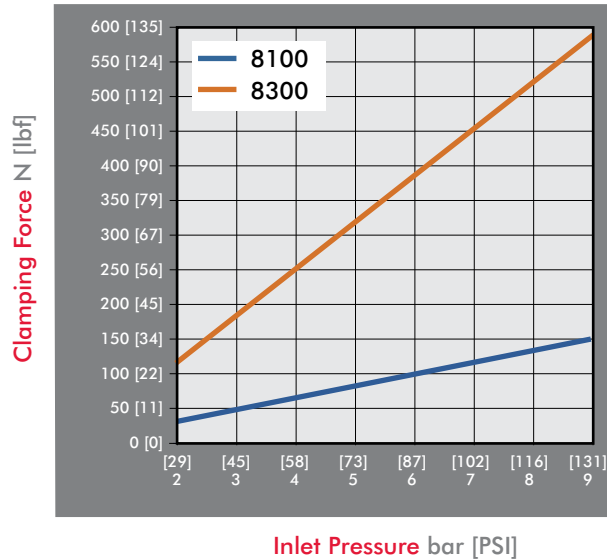

Series 89E, 8000, 8200, 8400 Product Overview

Features:

- Proven, reliable designs
- Lightweight and robust, designed for several million cycles
- Threaded body may be mounted in a tapped hole or through hole with mounting accessory

Applications:

- Assembly
- Welding
- Light machining

Also Available:

See page 12.2 - 12.5 for clamping arms and mounting accessories
See page 13.1 for sensing options

Series 89E ■



Available in 20, 30, 40, 50, and 63mm bore sizes
Clamping arms and mounting accessories sold separately, see page 12.2 - 12.5

Series 8000, 8200, 8400 ▲



Switches are optional. To order with (2) 810169 switches, add **A** to the end of the model. Ex. 8215-**A**.
Supplied with clamping arm and spindle.
To order without clamping arm add **-LA** to the end of the model. Ex. 8115-**LA**

Series 89E, 8000, 8200, 8400 Technical Information

Model	Swing	Total Stroke mm[in]	Travel During Rotation mm[in]	Vertical Clamp Stroke mm[in]	Bore Size mm[in]	Clamp Volume cm ³ [in. ³]	Unclamp Volume cm ³ [in. ³]	Clamping Force @ 6bar[87PSI] N[lbf.]†	Weight kg[lb.]	Seal Kit
■ 89E20-010-1R	R	[0.79]	[0.39]		[0.79]	[0.29]	[0.38]	[22]	[0.62]	8940-3-00
■ 89E20-010-1L	L	20	10		20	4,71	6,28	97	0,28	
■ 89E30-010-1R	R	[0.83]	[0.43]	[0.39]	[1.18]	[0.76]	[0.91]	[63]	[0.88]	8945-3-00
■ 89E30-010-1L	L	21	11	10	30	12,47	14,85	280	0,40	
■ 89E40-010-1R	R	[0.94]	[0.55]		[1.57]	[1.55]	[1.84]	[103]	[1.57]	8950-3-00
■ 89E40-010-1L	L	24	14		40	25,34	30,16	460	0,71	
■ 89E50-025-1R	R	[1.57]	[0.59]	[0.98]	[1.97]	[4.17]	[4.79]	[194]	[2.91]	8952-3-00
■ 89E50-025-1L	L	40	15	25	50	68,37	78,55	865	1,32	
■ 89E63-008-1R	R	[1.02]	[0.71]	[0.32]	[2.48]	[4.45]	[4.95]	[298]	[4.63]	8955-3-00
■ 89E63-008-1L	L	26	18	8	63	72,89	81,06	1,330	2,10	
▲ 8015	R	[0.85]	[0.47]	[0.38]	[0.75]	[0.25]	[0.38]	[25]		801560
▲ 8016	L	21,5	11,8	9,7	19,1	4,10	6,23	110		
▲ 8215	R				[1.50]	[2.01]	[2.26]	[89]	[1.69]	821560
▲ 8216	L	[1.25]	[0.75]	[0.50]	38,1	32,94	37,03	400	0,77	
▲ 8415	R	31,8	19,1	12,7	[1.19]	[1.17]	[1.42]	[68]		841560
▲ 8416	L				30,2	19,17	23,27	300		

† with standard clamping arm Preferred Market: ▲ NA/SA ■ Europe ● Global

Operating Pressure Range:

89B: 3bar [30psig] to 10bar [145psig] (89B20 8bar [116psig] max.)

8100, 8300: 3bar [30psig] to 9bar [130psig]

Series 89E Standard Clamp Dimensions

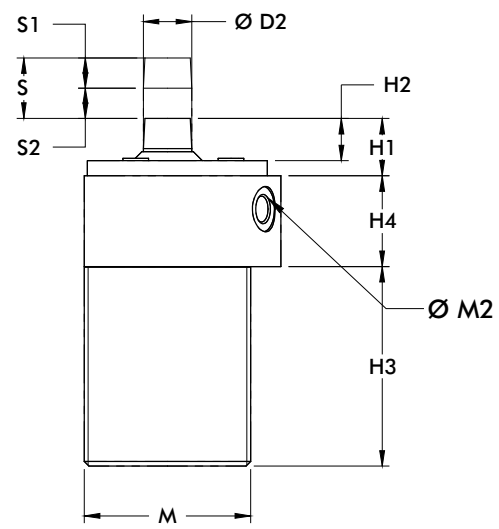
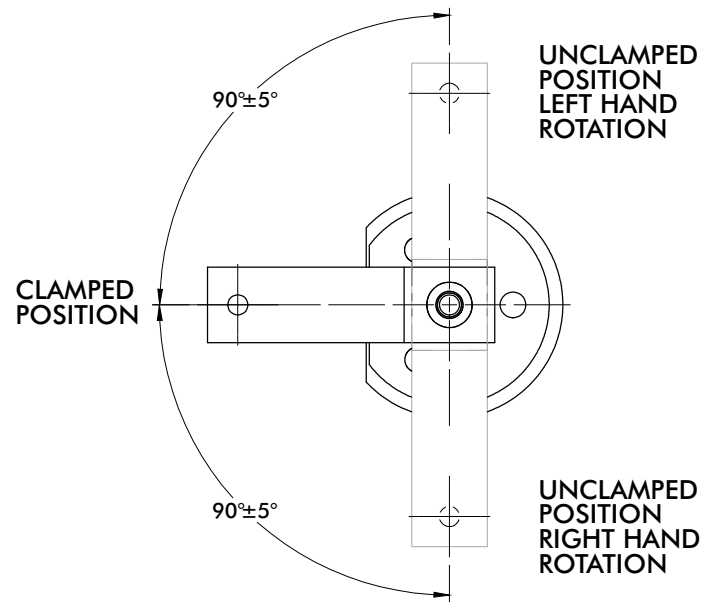
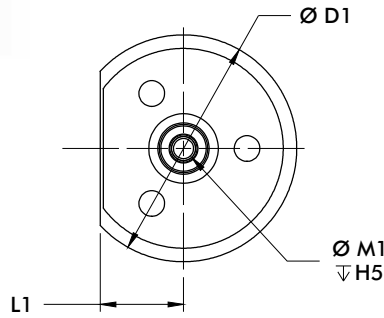

mm [INCH]
THIRD ANGLE PROJECTION

Mounting Options

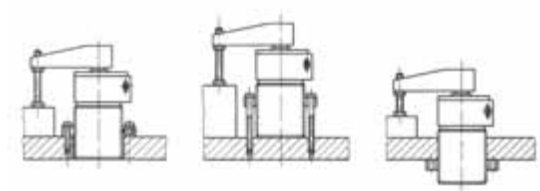

Model	ØD1	ØD2	H1	H2	H3	H4	H5	L1	M	M1	M1
89E20	[1.89] 48	[0.39] 10	[0.69] 17,5	[0.37] 9,5	[2.36] 60	[1.10] 28	[0.59] 15	[0.75] 19	M36X1,5	M5	M5
89E32	[2.52] 64	[0.47] 12	[0.63] 16	[0.43] 11	[2.72] 69	[0.98] 25	[0.67]	[0.89] 22,5	M42X1,5	M6	
89E40	[2.95] 75	[0.63] 16	[0.75] 19	[0.55] 14	[2.60] 66	[1.38] 35	17	[1.08] 27,5	M55X2	M8	G-1/8
89E50	[3.54] 90	[0.71] 18	[0.98] 25	[0.67] 17	[4.09] 104	[1.50]	[0.98] 25	[1.36] 34,5	M68X2	M10	
89E63	[4.13] 105	[0.79] 20	[1.06] 27	[0.75] 19	[3.03] 77	38	[0.79] 20	[1.57] 40	M80X2		G-1/4

Series 8000, 8200, 8400 Standard Clamp Dimensions

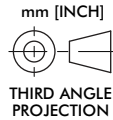
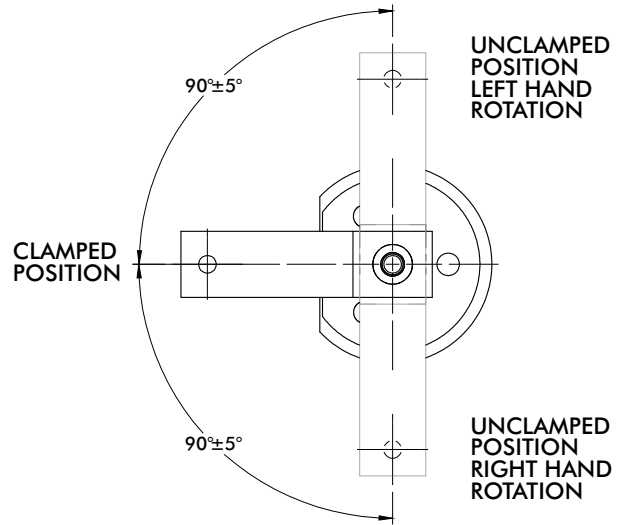
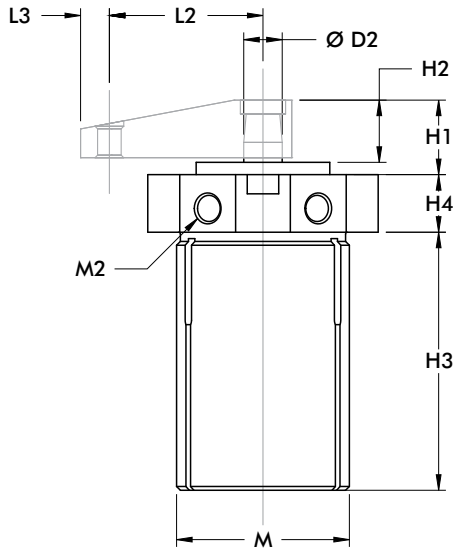
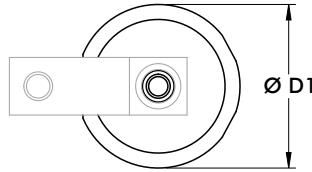
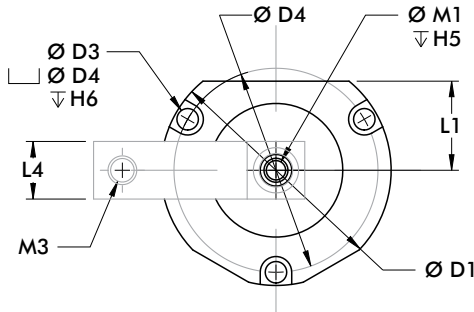

Model	ØD1	ØD2	ØD3	ØD4	H1	H2	H3	H4	H5	H6	L1	L2
8015	[1.25]	[0.44]	--	--	[0.53]	[0.41]	[2.87]	[0.50]	[0.75]	--	--	[1.12]
8016	31,8	11,1	--	--	13,5	10,4	72,9	12,7	19,1	--	--	28,4
8215	[3.00]		[0.28]	[2.66]	[0.97]	[0.81]	[3.36]			[0.25]	[1.16]	[2.00]
8216	76,2	[0.50]	7,1	67,6	24,6	20,6	85,3	[0.75]	[0.67]	6,4	29,5	50,8
		12,7	--	--				19,1	17	--	--	
8415	[2.13]		--	--	[0.94]	[0.78]	[3.17]			--	--	[1.56]
8416	54,1		--	--	23,9	19,8	80,5			--	--	39,6

Model	L3	L4	M	M1	M2	M3
8015	[0.31]	[0.62]	1-1/8-16	¼-20	#10-32	#10-32
8016	7,9	15,7				
8215			2-1/4-12			
8216	[0.38]	[0.75]		5/16-18	1/8 NPT	3/8-16
	9,6	19,1	1-3/4-12			
8415						
8416						

Series 89E, 8000, 8200, 8400 Clamping Forces

Series 89E Clamping Force
(w/ standard clamping arm)

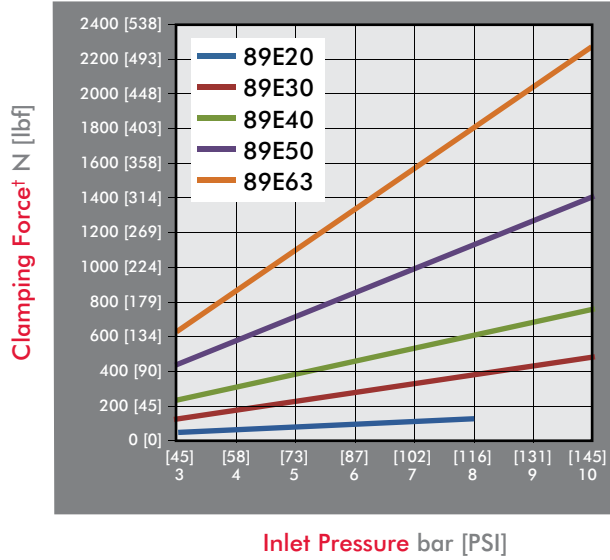

Series 8000, 8200, 8400 Clamping Force
(w/ standard clamping arm)

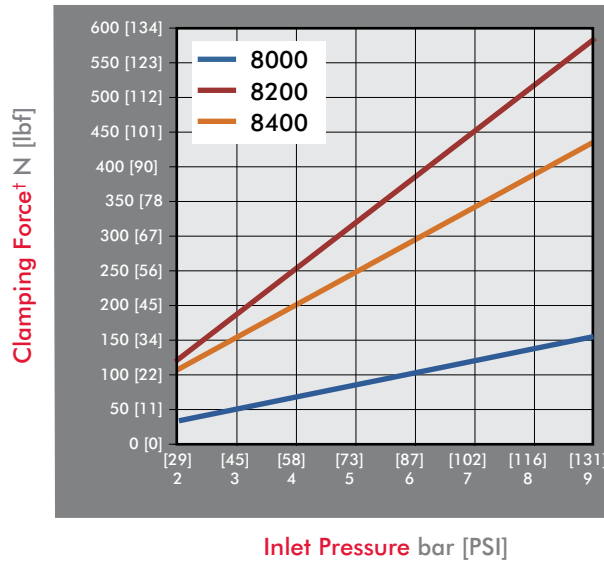

Series 035 Product Overview

Features:

- Available with threaded body, or lower flange mounting
- Low profile for confined spaces
- Double locked arm attachment is bolted to piston rod and clamped around shaft diameter
- Available in 25, 32, 40, and 50mm bore sizes

Applications:

- Assembly
- Welding
- Light machining

Also Available:

See page 12.3 - 12.4 for clamping arms and 12.10 for mounting accessories

Series 035-1 ▲



Threaded body design for mounting through fixture plates.

Series 035-2 ▲



Flanged body design for quick and easy mounting

Series 035 Technical Information

Model	Swing	Total Stroke mm[in]	Travel During Rotation mm[in]	Vertical Clamp Stroke mm[in]	Bore Size mm[in]	Clamp Volume cm ³ [in. ³]	Unclamp Volume cm ³ [in. ³]	Clamping Force @ 6bar[87PSI] N[lbf.]†	Weight kg[lb.]	Seal Kit
▲ 035-125-190	R	[1.04]	[0.51]	[0.53]	[0.98]	[0.54]	[0.79]	[27]	[0.56]	905516
▲ 035-125-290	L	26,3	12,8	13,5	25	8,87	12,92	120	0,25	
▲ 035-132-190	R	[1.13]	[0.56]	[0.57]	[1.26]	[1.06]	[1.41]	[40]	[0.94]	905517
▲ 035-132-290	L	28,8	14,3	14,5	32	17,34	23,13	180	0,43	
▲ 035-140-190	R	[1.20]	[0.57]	[0.63]	[1.57]	[1.96]	[2.33]	[70]	[1.31]	905518
▲ 035-140-290	L	30,4	14,4	16	40	32,1	38,21	312	0,59	
▲ 035-150-190	R	[1.18]	[0.63]	[0.55]	[1.97]	[3.02]	[3.59]	[90]	[1.81]	905519
▲ 035-150-290	L	30	16	14	50	49,49	58,91	400	0,82	
▲ 035-225-190	R	[1.05]	[0.54]	[0.51]	[0.98]	[0.55]	[0.80]	[27]	[0.56]	905516
▲ 035-225-290	L	26,7	13,7	13	25	9	13,11	120	0,25	
▲ 035-232-190	R	[1.06]	[0.57]	[0.49]	[1.26]	[0.99]	[1.32]	[40]	[1.13]	905517
▲ 035-232-290	L	26,8	14,4	12,4	32	16,17	21,56	180	0,51	
▲ 035-240-190	R	[1.09]	[0.57]	[0.52]	[1.57]	[1.78]	[2.13]	[70]	[1.40]	905518
▲ 035-240-290	L	27,7	14,4	13,3	40	29,26	34,83	312	0,64	
▲ 035-250-190	R	[1.13]	[0.63]	[0.51]	[1.97]	[2.90]	[3.45]	[90]	[1.90]	905519
▲ 035-250-290	L	28,8	16	12,8	50	47,52	56,57	400	0,86	

† with standard clamping arm Preferred Market: ▲ NA/SA ■ Europe ● Global

Operating Pressure Range:
7bar [100psig] max.

Application Note:

When arm length is longer than 80mm [3.15in.] pressure should be less than:
 25mm bore: 4,5bar [80psig]
 32/40mm bore: 5,5 bar [80 psig]
 50mm bore: 7 bar [100psig]

Series 035 Standard Clamp Dimensions



Series 035-1

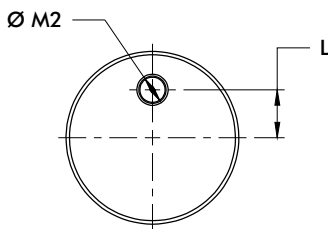
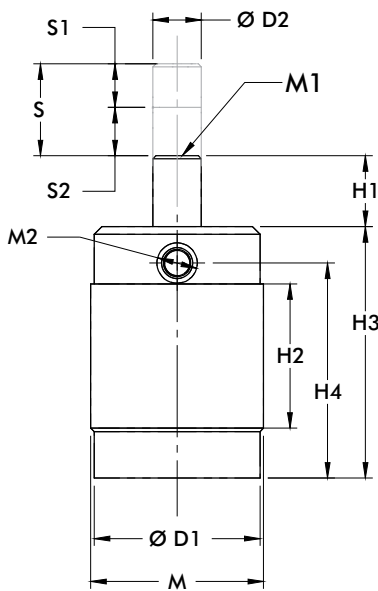

Series 035-2

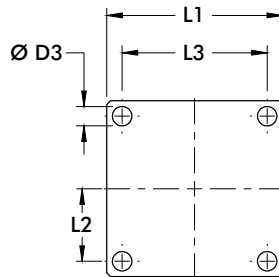
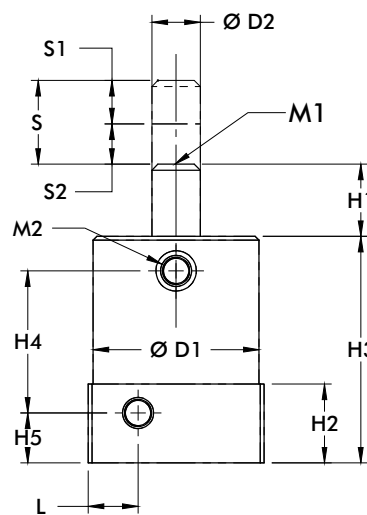

Series 035 Clamping Force (w/ standard clamping arm)

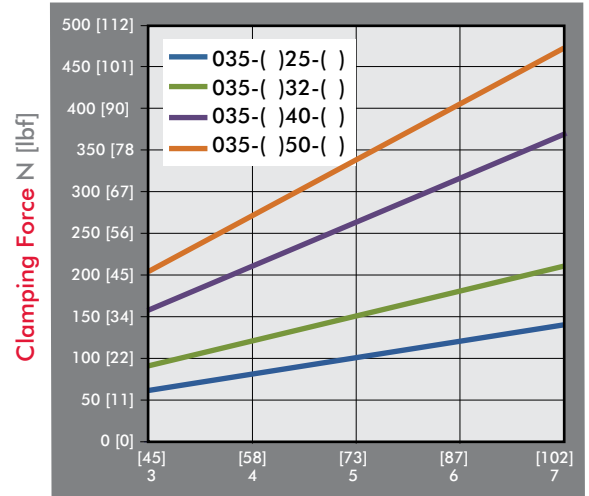

Inlet Pressure bar [PSI]

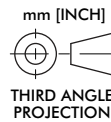

Model	ØD1	ØD2	H1	H2	H3	H4	H5	L	L1	L2	L3	M	M1	M1
035-125-()	[1.42] 36	[.55] 14	[0.57] 14,4	[1.50] 38,1	[2.76] 70	[2.25] 57,2	--	[0.35] 9	--	--	--	1-½ -16	1/4-20	#10-32
035-132-()	[1.79] 45,4	[0.63] 16	[0.75] 19,1	[1.72] 43,7	[3.87] 98,2	[2.63] 66,7	--	[0.45] 11,4	--	--	--	1-7/8-16	5/16-18	1/8 NPT
035-140-()	[2.16] 54,8	[0.76] 19,4	[1.88] 47,7	[3.28] 83,2	[2.80] 71	--	[0.70] 17,8	--	--	--	--	2-1/4-16	3/8-16	1/8 NPT
035-150-()	[2.36] 60	[0.79] 20	[2.00] 50,8	[3.48] 88,3	[2.95] 75	--	[0.50] 12,7	--	--	--	--	2-1/2-16	3/8-16	1/8 NPT
035-225-()	[1.38] 35	[.55] 14	[0.60] 15,2	[.91] 23	[2.62] 66,5	[1.60] 40,6	[0.50] 12,7	[0.57] 14,5	[1.57] 40	[0.61] 15,5	[1.22] 31	--	1/4-20	#10-32
035-232-()	[1.97] 50	[0.63] 16	[0.85] 21,6	[2.79] 71	[1.76] 44,6	[0.57] 114,5	[0.65] 16,5	[2.13] 54	[0.87] 22	[1.73] 44	--	--	5/16-18	1/8 NPT
035-240-()	[2.16] 54,8	[0.94] 23,9	[1.03] 26,1	[2.95] 75	[1.85] 47	[0.65] 16,5	[0.65] 16,5	[2.29] 58,2	[0.94] 24	[1.89] 48	--	--	3/8-16	1/8 NPT
035-250-()	[2.36] 60	[0.79] 20	[1.03] 26	[3.15] 80	[2.05] 52	--	[2.68] 68	[1.08] 27,5	[2.17] 55	--	--	--	3/8-16	1/8 NPT