

CLIMAX

METAL PRODUCTS COMPANY

ISO 9001:2008

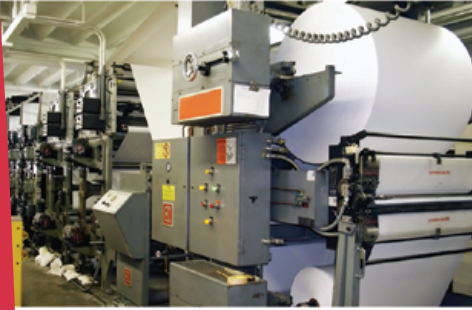

- LOCKING ASSEMBLIES
- SHRINK DISCS
- KEYLESS RIGID COUPLINGS



Why Go Keyless?

Traditional Connection Methods for Rotating Power Transmission Components

Traditionally, drive elements like gears, sprockets, lever arms, etc. were affixed to rotating shafts using a keyway and key, perhaps with a setscrew to fix axial positioning during operation. These connections, while relatively simple and reliable when transmitting smooth, consistent power, prove inadequate when vibratory, shock or reversing loads are present. Keyed connections subjected to such extreme operating environments will pound out over time, as each time the load reverses or cycles off and on, the drive element spins on the shaft through the clearance between key and keyway, then stops abruptly upon contacting the key. This phenomenon is typically referred to as “backlash”. Further, the rubbing between shaft and component bore surfaces during this slippage leads to fretting corrosion, which over time can cause cold welding of components and could ultimately lead to weakened shafts and/or shaft failures. Splined connections, albeit to a lesser degree, suffer from the same limitations as keyed connections, with their extremely high fabrication costs an additional drawback.

Interference Fits

A frictional connection between shaft and component solves the problems associated with backlash, and additionally eliminates the machining operations required for keyways. Further, shafts, along with any other required drive elements, can be made smaller once the keyway notch factor is removed. These frictional connections, in the form of heat shrink or press fits, provide an even pressure distribution and are entirely backlash-free. As a result, an interference fit will never pound out or fret, provided the interference preload is sufficiently greater than the applied load. The limitations of this approach, however, quickly become apparent during assembly and removal, where application of heat and/or very high forces is required.

CLIMAX Keyless Locking Devices

CLIMAX Keyless Locking Devices provide the ultimate solution by delivering all of the advantages of interference fits with none of the installation and removal limitations. Our Locking Assemblies, Shrink Discs and Keyless Rigid Couplings offer a zero-backlash component mounting or coupling solution using multiple high strength screws and opposing tapers to develop a mechanically generated interference fit. Installation and removal is accomplished with simple hand tools, greatly simplifying component positioning and field maintenance.

CLIMAX Keyless Locking Devices offer advantages over all other component mounting technologies.

	CLIMAX Keyless Locking Devices	Key and Keyway	Spline	QD or Taper Lock Bushing	Shrink or Press Fit
Provide a zero-backlash connection	✓	—	—	—	✓
Eliminate keyway notch factor/allow smaller shafts	✓	—	—	—	✓
Easily installed and removed with hand tools	✓	✓	✓	✓	—
Permit infinite axial and angular timing	✓	—	—	—	—
Transmit torque, bending and axial thrust	✓	—	—	—	✓

CLIMAX Keyless Locking Device Standard Product Line

CLIMAX Keyless Locking Devices are sold in a variety of styles to suit nearly any application:



Series C193 Locking Assembly (Product Specifications On Page 9)

- Single taper, compact design for smaller shaft diameters
- Self-centering for excellent concentricity
- No axial movement of mounted component during installation



Series C133 Locking Assembly (Product Specifications On Pages 10-11)

- Single taper design with flange
- Excellent concentricity
- No axial movement of mounted component during installation



Series C123 Locking Assembly (Product Specifications On Pages 12-13)

- Single taper design
- Flangeless design mounts flush inside component bore
- Mounted component moves axially during installation



Series C200 Locking Assembly (Product Specifications On Pages 14-15)

- Original double taper, self-releasing design
- First-generation device; not self-centering
- No axial movement of mounted component during installation



Series C170 Locking Assembly (Product Specifications On Pages 16-17)

- Single taper design with flange and integrated spacer
- Excellent concentricity
- Thin cross section accommodates smaller diameter mounted component



Series C405 Locking Assembly (Product Specifications On Pages 18-19)

- Heavy duty
- Wider design transmits higher torque and bending moments
- Excellent concentricity; extremely robust for the most demanding applications



Series C415 Locking Assembly (Product Specifications On Page 20)

- Medium duty
- Wider design transmits higher torque and bending moments
- Excellent concentricity



Series C733 Shrink Disc (Product Specifications On Page 21)

- External keyless locking device
- Inherently balanced for high speed applications
- Preferred solution for coupling hubs and hollow shaft gearboxes



Series C600 Keyless Rigid Couplings (Product Specifications On Pages 22-23)

- Cost effective shaft-to-shaft keyless coupling
- High torque and bending moment capacity
- Preferred solution for torque-arm mounted hydraulic drives
- Available with stepped bore upon request

Engineering / Technical Information

Selection

CLIMAX Keyless Locking Devices are designed to transmit torque, bending, thrust and radial loads, both static and dynamic, individually and in various combinations. The following information is provided to assist in proper selection:

Torque

Many CLIMAX Keyless Locking Devices will be used in applications subjected to torque only. In these applications the **Peak Torque = T** must be calculated and compared to the **Rated Torque Capacity M_t** of the CLIMAX KLD being considered.

M_t (from specification tables) > T

If **Peak Torque T** cannot be determined with accuracy, it is recommended that **Nominal Torque = T_{nom}** be used instead, along with an appropriate **Service Factor** to account for start-up or stall conditions, mass accelerations, impact loads, etc.

Nominal Torque T_{nom} can be calculated as follows:

$$T_{nom} \text{ (ft-lb)} = \frac{5252 \times \text{HP}}{\text{RPM}}$$

M_t (from specification tables) > $T_{nom} \times \text{Service Factor}$

Note that in all cases our published **Rated Torque Capacity M_t** is calculated without using a safety factor. Accordingly it should be assumed that a CLIMAX Keyless Locking Device connection will slip if a torque higher than M_t is applied.

All published capacities and contact pressures assume that locking screws are tightened to the published **Locking Screw Tightening Torque M_a** according to Climax Installation and Removal Instructions. If required, torque capacities and contact pressures for installed units can be manipulated within certain limits by adjusting **Locking Screw Tightening Torque M_a** from its published value, as follows:

- Series C200:..... up to 20% higher or up to 40% lower
- Series C133/C193:..... up to 40% lower
- Series C123:..... up to 10% lower
- Series C170:..... up to 20% lower
- Series C405/C415:..... up to 40% lower

Within these limits, **Rated Torque Capacity M_t** , **Rated Thrust Capacity F_{ax}** and **Contact Pressures P_s and P_h** are a linear function of **Locking Screw Tightening Torque M_a** .

For applications requiring 2 or more CLIMAX Keyless Locking Devices installed in series, please consult with Climax for proper selection.

Engineering / Technical Information *(Continued)*

Thrust

The radial force applied to the shaft and mounted component by a CLIMAX KLD will resist a significant amount of axial thrust. The **Rated Thrust Capacity F_{ax}** of any CLIMAX KLD is determined using the following equation:

$$F_{ax} \text{ (lbs.F)} = \frac{24 \times M_t}{d}$$

M_t = **Rated Torque Capacity** (from specification tables)

d = shaft diameter (in)

Bending Moments

Reversing bending moments are a frequently overlooked sizing factor in mechanical power transmission applications. Bending loads are present whenever a radial load – from the weight of components, belt or chain tension, etc. – acts outside the centerline of the shaft/hub connection. Reversing bending moments occur when such loads cycle between tension and compression as a mounted component rotates through 360 degrees, as is the case on rolls or conveyor pulleys. Most traditional component mounting technologies – keys and keyways, QD-style or Taper-Lock bushing systems, etc. – are not designed to transmit reversing bending loads and these conditions will typically lead to failure, whether of the connection itself, the mounted component or the shaft.

CLIMAX Keyless Locking Devices are specifically designed to transmit reversing bending moments within the following limits:

Climax Series	Rated Bending Moment Capacity M_b
C200	22% of M_t
C733 and C600	25% of M_t
C123, C133 and C193	28% of M_t
C415	32% of M_t
C405	35% of M_t

Combined Loads

It is not uncommon for CLIMAX Keyless Locking Devices to be subjected to some combination of **torque**, **axial thrust** and **reversing bending**. Our products are well suited for these environments, but proper selection requires calculating a **resultant torque** using the various applied loads, as follows:

$$T_{res} = \sqrt{T^2 + (F \times \frac{d}{2})^2 + (2 \times B)^2}$$

T = Peak Torque (ft-lbs)

F = Peak Thrust (lbs)

B = Peak Bending Moment (ft-lbs)

d = shaft diameter (ft)

M_t (from specification tables) > T_{res}

and

M_b (see below) > B

Engineering / Technical Information *(Continued)*

Radial Loads

Radial loads, typically associated with pin or axle connections, occur when an applied load F_{rad} acts perpendicular to the centerline of the shaft. Selection of a suitable CLIMAX Keyless Locking Device is based on determining the equivalent contact pressure on the shaft P_{rad} , as follows:

$$P_{rad} = \frac{F_{rad}}{d \times L}$$

F_{rad} = applied radial load (lbs.F)

d = shaft diameter (in)

L = KLD contact length (in) (from specification tables)

Then an acceptable radial load application is one in which $P_s > P_{rad}$, AND $P_s + P_{rad} < YP$, where:

P_s = shaft contact pressure (from specification tables)

YP = tensile yield point of shaft material (psi)

Material

CLIMAX Keyless Locking Devices are manufactured from high carbon and alloy steel.

Surface Finish and Lubricity

CLIMAX Keyless Locking Devices carry rated capacities that rely upon both lubricity and surface finish. Components to be mounted using a CLIMAX KLD should be machined to achieve a surface finish of between 63 and 125 μ N RMS. A surface finish outside this range could result in a reduction of the load carrying capacity of the connection. Lubricity is likewise critically important to the successful application of our products, as it directly affects the Coefficient of Friction (COF) between mated components. Our internal Locking Assemblies are supplied and installed with ordinary machine oil on all locking screws and mated surfaces to achieve a COF equal to .12. Our external Shrink Discs and Keyless Rigid Couplings require a solvent cleaned and dry shaft interface to achieve a COF equal to .15.

Temperature

CLIMAX Keyless Locking Devices are designed to operate through a temperature range of 0° to 400° F. Note that mated components of dissimilar materials may react to temperature increases at different rates. Please consult with Climax regarding such applications.

Mounting Over Existing Keyways

CLIMAX Keyless Locking Devices can be installed over existing empty keyways. Both Climax Locking Assemblies and Shrink Discs should be rotated to position inner ring radial slits approximately opposite the keyway and a locking screw directly over the keyway. CLIMAX Keyless Locking Devices are not de-rated when installed over existing empty keyways.

Engineering / Technical Information *(Continued)*

Non-Standard Shaft Diameters

In situations where the measured shaft diameter does not match any standard Climax Locking Assembly, perhaps as a result of damage or excessive wear, a simple adapter sleeve can be fabricated to effectively “shim” the existing shaft to a standard nominal diameter. These adaptor sleeves can be slit lengthwise or left solid, with slit sleeves allowing more relaxed machining tolerances. Wall thickness should not exceed 12.5% of measured shaft diameter. Recommended machining tolerances are as follows:

- +0 / -.002" on the sleeve OD;
- 0 / +.001" – .002" on the bore of a solid sleeve;
- 0 / +.002" – .004" on the bore of a slit sleeve.

For slit adaptor sleeves rated torque capacities for these connections is taken directly from the Climax Locking Assembly selected, provided the adaptor sleeve/shaft interface is clean and dry (for a coefficient of friction equal to .15) and the adaptor wall thickness is within prescribed limits.

Plating

Climax Locking Assemblies and Keyless Rigid Couplings are stocked unplated, while Shrink Discs are supplied with zinc-plated outer rings. Upon request, all CLIMAX Keyless Locking Devices can be quoted with either of two after-market plating options: industry-standard electroless Nickel or Armoloy® Thin Dense Chrome (TDC). Both plating solutions offer excellent corrosion resistance with no reduction of rated torque capacity.

Hub Strength

Calculations to Ensure Adequate Hub Dimensions

As CLIMAX Keyless Locking Devices exert high compression and expansion forces, the following formulas are presented to assist with calculations required to ensure that components mounted with our products are of adequate strength.

Applications Using Climax Locking Assemblies

To ensure adequate wall thickness of the mounted component, use the following equation:

$$D_n = D \sqrt{\frac{YP + (P_h \times C)}{YP - (P_h \times C)}}$$

D = the published OD (in inches) of the Locking Assembly selected (from specification tables)

P_h = hub contact pressure (in psi) of the Locking Assembly selected (from specification tables)

YP = the tensile yield point (in psi) of the mounted component

C = a Pressure Reduction Factor selected based on the relationship between the length-thru-bore (LTB) of the mounted component and the contact length (L) of the Locking Assembly selected, as shown below:

For C123, C133, C193, C200 and C170

- When LTB < 1.5 x L, C = 1.0
- When 1.5 x L ≤ LTB < 2 x L, C = .8
- When LTB ≥ 2 x L, C = .6

For C405 and C415

- When LTB < 1.25 x L, C = 1.0
- When 1.25 x L ≤ LTB < 1.5 x L, C = .8
- When LTB ≥ 1.5 x L, C = .6

Hub Strength *(Continued)*

Applications Using Climax Shrink Discs

The component hub wall thickness for Shrink Disc applications is nominally the difference between the Shrink Disc ID and the shaft diameter. As we do not wish for the use of our products to weaken the drive system, our specifications limit the size of the shaft diameter recommended for use with each Shrink Disc to a size which results in a component hub that is at least as strong, both in bending and in torsion, as the underlying shaft.

In general, component hub material with a minimum tensile yield point of 45ksi is recommended. Cast iron component hubs are acceptable, but we recommend selecting the next larger size Shrink Disc for these applications.

To eliminate possible fretting corrosion and associated complications, when machining a hub for use under a Shrink Disc, it is recommended that the fit length be limited to the Shrink Disc inner ring length (L from the specification tables), with the remaining LTB relieved using a non-toleranced clearance. See the illustration atop page 21.

Shaft and Hub Tolerances

		Ø Hub Diameter (inch)							
over		0.24	1	1.97	2.56	4.72	9.25	12.01	14.76
including		1	1.97	2.56	4.72	9.25	12.01	14.76	25*
		Ø Hub Diameter (mm)							
over		6	25.4	50	65	120	235	305	375
including		25.4	50	65	120	235	305	375	635
C193 [-0.0]	inch	+0.001	+0.001	+0.001					
	mm	+0.025	+0.025	+0.025					
C123/C133 [-0.0]	inch	+0.002	+0.002	+0.002	+0.002	+0.003	+0.003	+0.004	+0.004
	mm	+0.05	+0.05	+0.05	+0.05	+0.08	+0.08	+0.10	+0.10
C170 [-0.0]	inch	+0.002	+0.002	+0.002	+0.003	+0.003			
	mm	+0.05	+0.05	+0.05	+0.08	+0.08			
C200 [-0.0]	inch	+0.002	+0.002	+0.003	+0.003	+0.004	+0.005	+0.005	+0.006
	mm	+0.05	+0.05	+0.08	+0.08	+0.10	+0.13	+0.13	+0.15
C405/C415 [-0.0]	inch	+0.002	+0.002	+0.002	+0.002	+0.003	+0.003	+0.004	+0.004
	mm	+0.05	+0.05	+0.05	+0.05	+0.08	+0.08	+0.10	+0.10
		Ø Shaft Diameter (inch)							
over		0.24	1	1.97	2.56	4.72	9.25	12.01	14.76
including		1	1.97	2.56	4.72	9.25	12.01	14.76	25*
		Ø Shaft Diameter (mm)							
over		6	25.4	50	65	120	235	305	375
including		25.4	50	65	120	235	305	375	635
C193 [+0.0]	inch	-0.001	-0.001	-0.001					
	mm	-0.025	-0.025	-0.025					
C123/C133 [+0.0]	inch	-0.002	-0.002	-0.002	-0.002	-0.003	-0.003	-0.004	-0.004
	mm	-0.05	-0.05	-0.05	-0.05	-0.08	-0.08	-0.10	-0.10
C170 [+0.0]	inch	-0.002	-0.002	-0.002	-0.003	-0.003			
	mm	-0.05	-0.05	-0.05	-0.08	-0.08			
C200 [+0.0]	inch	-0.002	-0.002	-0.003	-0.003	-0.004	-0.005	-0.005	-0.006
	mm	-0.05	-0.05	-0.08	-0.08	-0.10	-0.13	-0.13	-0.15
C405/C415 [+0.0]	inch	-0.002	-0.002	-0.002	-0.002	-0.003	-0.003	-0.004	-0.004
	mm	-0.05	-0.05	-0.05	-0.05	-0.08	-0.08	-0.10	-0.10
C600 [+0.0]	inch	-0.003	-0.006	-0.006	-0.006	-0.006			
	mm	-0.08	-0.15	-0.15	-0.15	-0.15			

*Consult Climax for diameters in excess of those shown

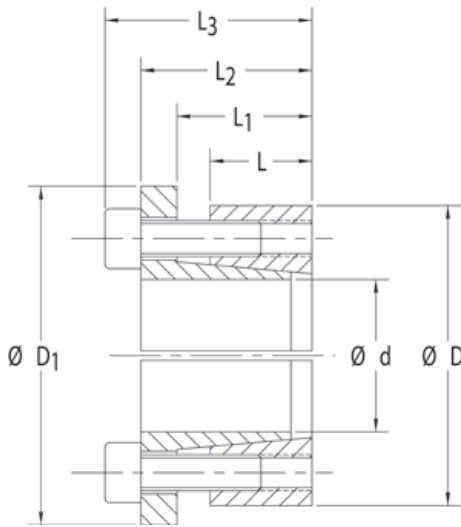

SERIES C193 LOCKING ASSEMBLY

- Single taper, compact design for smaller shaft diameters
- Self-centering for excellent concentricity
- No axial movement of mounted component during installation



C193

Inch

Climax Part No.	Shaft Size (in)								M_t (in-lbs)	F_{ax} (lbs.F)	P_s (psi)	P_h (psi)	D_n^*	Locking Screws		
	d	D	D_1	L	L_1	L_2	L_3	Qty.						Size	M_a (in-lbs)	
C193E-025	1/4	0.2500	0.8125	0.9375	0.394	0.516	0.650	0.807	185	1,479	39,820	12,252	1.074	3	M4 x 12	40
C193E-031	5/16	0.3125	0.8750	1.0000	0.394	0.516	0.650	0.807	257	1,643	35,396	12,641	1.168	3	M4 x 12	44
C193E-037	3/8	0.3750	0.9375	1.0625	0.394	0.516	0.650	0.807	308	1,643	29,496	11,799	1.226	3	M4 x 12	44
C193E-050	1/2	0.5000	1.0625	1.1875	0.394	0.516	0.650	0.807	548	2,191	29,496	13,881	1.462	4	M4 x 12	44
C193E-062	5/8	0.6250	1.1875	1.3125	0.472	0.594	0.807	0.964	1,027	3,286	29,546	15,551	1.703	6	M4 x 14	44
C193E-075	3/4	0.7500	1.3125	1.4375	0.472	0.594	0.807	0.964	1,232	3,286	24,622	14,070	1.814	6	M4 x 14	44
C193E-087	7/8	0.8750	1.5625	1.7500	0.591	0.754	0.984	1.181	2,309	5,277	27,070	15,159	2.219	6	M5 x 18	89
C193E-100	1	1.0000	1.6875	1.8750	0.591	0.754	0.984	1.181	3,518	7,037	31,582	18,715	2.627	8	M5 x 18	89
C193E-112	1 1/8	1.1250	1.8750	2.0000	0.669	0.829	1.102	1.299	4,453	7,916	27,900	16,740	2.771	9	M5 x 18	89
C193E-118	1 3/16	1.1875	1.9375	2.0625	0.669	0.829	1.102	1.299	5,222	8,796	29,368	18,000	2.960	10	M5 x 18	89
C193E-125	1 1/4	1.2500	2.0000	2.1250	0.669	0.829	1.102	1.299	5,497	8,796	27,900	17,437	3.010	10	M5 x 18	89
C193E-137	1 3/8	1.3750	2.1250	2.2500	0.669	0.829	1.102	1.299	6,047	8,796	25,364	16,412	3.115	10	M5 x 18	89

Metric

Climax Part No.	Shaft Size (mm)								M_t (in-lbs)	F_{ax} (lbs.F)	P_s (psi)	P_h (psi)	D_n^*	Locking Screws		
	d	D	D_1	L	L_1	L_2	L_3	Qty.						Size	M_a (in-lbs)	
C193M- 6	6	0.2362	0.8125	0.9375	0.394	0.516	0.650	0.807	175	1,479	42,143	12,252	1.074	3	M4 x 12	40
C193M- 8	8	0.3150	0.8750	1.0000	0.394	0.516	0.650	0.807	259	1,643	35,119	12,641	1.168	3	M4 x 12	44
C193M- 10	10	0.3937	0.9375	1.0625	0.394	0.516	0.650	0.807	323	1,643	28,095	11,799	1.226	3	M4 x 12	44
C193M- 11	11	0.4331	1.0625	1.1875	0.394	0.516	0.650	0.807	474	2,191	34,055	13,881	1.462	4	M4 x 12	44
C193M- 12	12	0.4724	1.0625	1.1875	0.394	0.516	0.650	0.807	517	2,191	31,217	13,881	1.462	4	M4 x 12	44
C193M- 14	14	0.5512	1.1875	1.3125	0.472	0.594	0.807	0.964	906	3,286	33,504	15,551	1.703	6	M4 x 14	44
C193M- 15	15	0.5906	1.1875	1.3125	0.472	0.594	0.807	0.964	970	3,286	31,270	15,551	1.703	6	M4 x 14	44
C193M- 16	16	0.6299	1.1875	1.3125	0.472	0.594	0.807	0.964	1,035	3,286	29,316	15,551	1.703	6	M4 x 14	44
C193M- 19	19	0.7480	1.3125	1.4375	0.472	0.594	0.807	0.964	1,229	3,286	24,687	14,070	1.814	6	M4 x 14	44
C193M- 20	20	0.7874	1.5625	1.7500	0.591	0.754	0.984	1.181	2,078	5,277	30,082	15,159	2.219	6	M5 x 18	89
C193M- 22	22	0.8661	1.5625	1.7500	0.591	0.754	0.984	1.181	2,285	5,277	27,347	15,159	2.219	6	M5 x 18	89
C193M- 24	24	0.9449	1.6875	1.8750	0.591	0.754	0.984	1.181	3,324	7,037	33,424	18,715	2.627	8	M5 x 18	89
C193M- 25	25	0.9843	1.6875	1.8750	0.591	0.754	0.984	1.181	3,463	7,037	32,087	18,715	2.627	8	M5 x 18	89
C193M- 28	28	1.1024	1.8750	2.0000	0.669	0.829	1.102	1.299	4,363	7,916	28,473	16,740	2.771	9	M5 x 18	89
C193M- 30	30	1.1811	1.9375	2.0625	0.669	0.829	1.102	1.299	5,194	8,796	29,527	18,000	2.960	10	M5 x 18	89
C193M- 32	32	1.2598	2.0000	2.1250	0.669	0.829	1.102	1.299	5,541	8,796	27,682	17,437	3.010	10	M5 x 18	89
C193M- 35	35	1.3780	2.1250	2.2500	0.669	0.829	1.102	1.299	6,060	8,796	25,309	16,412	3.115	10	M5 x 18	89

All dimensions are shown in inches unless stated otherwise. All dimensions and capacities are subject to change without notice.

* Minimum hub outside diameter based on a Pressure Reduction Factor of C=1.0 and hub material with tensile yield point \geq 45,000 psi. For details refer to page 7.



SERIES C133 LOCKING ASSEMBLY

- Single taper design with flange
- Excellent concentricity
- No axial movement of mounted component during installation

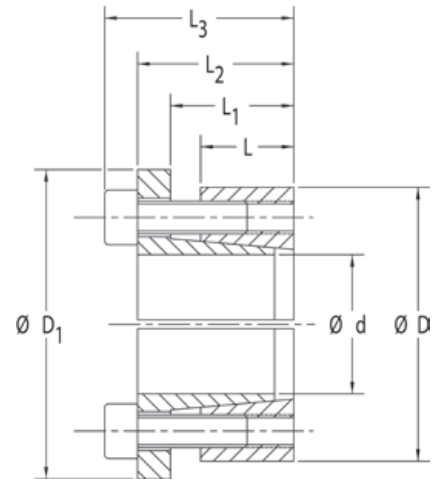

Inch

Climax Part No.	Shaft Size (in)	d	D	D ₁	L	L ₁	L ₂	L ₃	M _t (ft-lbs)	F _{ax} (lbs.F)	P _s (psi)	P _h (psi)	D _n *	Locking Screws		
														Qty.	Size	M _a [ft-lbs]
C133E-075	3/4	0.750	1.850	2.047	0.669	0.886	1.122	1.358	196	6,265	33,106	13,418	2.517	5	M6 x 20	13
C133E-087	7/8	0.875	1.850	2.047	0.669	0.886	1.122	1.358	228	6,265	28,376	13,418	2.517	5	M6 x 20	13
C133E-100	1	1.000	1.969	2.224	0.669	0.886	1.122	1.358	313	7,518	29,795	15,136	2.793	6	M6 x 20	13
C133E-112	1 1/8	1.125	2.165	2.421	0.669	0.886	1.122	1.358	352	7,518	26,485	13,760	2.970	6	M6 x 20	13
C133E-118	1 3/16	1.188	2.165	2.421	0.669	0.886	1.122	1.358	372	7,518	25,091	13,760	2.970	6	M6 x 20	13
C133E-125	1 1/4	1.250	2.362	2.618	0.669	0.886	1.122	1.358	522	10,024	31,781	16,818	3.499	8	M6 x 20	13
C133E-137	1 3/8	1.375	2.362	2.618	0.669	0.886	1.122	1.358	574	10,024	28,892	16,818	3.499	8	M6 x 20	13
C133E-143	1 7/16	1.438	2.559	2.815	0.669	0.886	1.122	1.358	600	10,024	27,636	15,524	3.667	8	M6 x 20	13
C133E-150	1 1/2	1.500	2.559	2.815	0.669	0.886	1.122	1.358	626	10,024	26,485	15,524	3.667	8	M6 x 20	13
C133E-162	1 5/8	1.625	2.953	3.287	0.787	1.043	1.358	1.673	1,097	16,206	33,596	18,489	4.569	7	M8 x 25	30
C133E-168	1 11/16	1.688	2.953	3.287	0.787	1.043	1.358	1.673	1,139	16,206	32,351	18,489	4.569	7	M8 x 25	30
C133E-175	1 3/4	1.750	2.953	3.287	0.787	1.043	1.358	1.673	1,182	16,206	31,196	18,489	4.569	7	M8 x 25	30
C133E-187	1 7/8	1.875	3.150	3.484	0.787	1.043	1.358	1.673	1,266	16,206	29,116	17,333	4.728	7	M8 x 25	30
C133E-193	1 15/16	1.938	3.150	3.484	0.787	1.043	1.358	1.673	1,308	16,206	28,177	17,333	4.728	7	M8 x 25	30
C133E-200	2	2.000	3.150	3.484	0.787	1.043	1.358	1.673	1,350	16,206	27,297	17,333	4.728	7	M8 x 25	30
C133E-212	2 1/8	2.125	3.346	3.681	0.787	1.043	1.358	1.673	1,640	18,521	29,361	18,644	5.200	8	M8 x 25	30
C133E-218	2 3/16	2.188	3.346	3.681	0.787	1.043	1.358	1.673	1,688	18,521	28,522	18,644	5.200	8	M8 x 25	30
C133E-225	2 1/4	2.250	3.543	3.858	0.787	1.043	1.358	1.673	1,736	18,521	27,730	17,608	5.357	8	M8 x 25	30
C133E-237	2 3/8	2.375	3.543	3.858	0.787	1.043	1.358	1.673	1,833	18,521	26,270	17,608	5.357	8	M8 x 25	30
C133E-243	2 7/16	2.438	3.740	4.016	0.787	1.043	1.358	1.673	2,116	20,836	28,796	18,767	5.831	9	M8 x 25	30
C133E-250	2 1/2	2.500	3.740	4.016	0.787	1.043	1.358	1.673	2,170	20,836	28,076	18,767	5.831	9	M8 x 25	30
C133E-256	2 9/16	2.563	3.740	4.016	0.787	1.043	1.358	1.673	2,225	20,836	27,392	18,767	5.831	9	M8 x 25	30
C133E-268	2 11/16	2.688	4.331	4.685	0.945	1.201	1.594	1.988	3,405	30,403	31,759	19,708	6.927	8	M10 x 30	61
C133E-275	2 3/4	2.750	4.331	4.685	0.945	1.201	1.594	1.988	3,484	30,403	31,037	19,708	6.927	8	M10 x 30	61
C133E-287	2 7/8	2.875	4.528	4.882	0.945	1.201	1.594	1.988	3,642	30,403	29,687	18,852	7.075	8	M10 x 30	61
C133E-293	2 15/16	2.938	4.528	4.882	0.945	1.201	1.594	1.988	3,721	30,403	29,056	18,852	7.075	8	M10 x 30	61
C133E-300	3	3.000	4.724	5.079	0.945	1.201	1.594	1.988	3,800	30,403	28,450	18,066	7.229	8	M10 x 30	61
C133E-325	3 1/4	3.250	4.921	5.276	0.945	1.201	1.594	1.988	4,632	34,204	29,545	19,511	7.829	9	M10 x 30	61
C133E-337	3 3/8	3.375	4.921	5.276	0.945	1.201	1.594	1.988	4,810	34,204	28,450	19,511	7.829	9	M10 x 30	61
C133E-343	3 7/16	3.438	5.118	5.472	0.945	1.201	1.594	1.988	4,899	34,204	27,933	18,761	7.978	9	M10 x 30	61
C133E-350	3 1/2	3.500	5.118	5.472	0.945	1.201	1.594	1.988	4,988	34,204	27,434	18,761	7.978	9	M10 x 30	61
C133E-375	3 3/4	3.750	5.315	5.669	0.945	1.201	1.594	1.988	5,938	38,004	28,450	20,073	8.588	10	M10 x 30	61
C133E-393	3 15/16	3.938	5.709	6.063	1.024	1.299	1.772	2.244	7,449	45,406	29,883	20,611	9.363	8	M12 x 35	107
C133E-400	4	4.000	5.709	6.063	1.024	1.299	1.772	2.244	7,568	45,406	29,416	20,611	9.363	8	M12 x 35	107
C133E-443	4 7/16	4.438	6.102	6.457	1.024	1.299	1.772	2.244	8,395	45,406	26,516	19,281	9.648	8	M12 x 35	107
C133E-475	4 3/4	4.750	6.496	6.850	1.024	1.299	1.772	2.244	10,110	51,081	27,867	20,377	10.585	9	M12 x 35	107
C133E-493	4 15/16	4.938	7.087	7.441	1.339	1.614	2.165	2.717	14,135	68,706	27,575	19,212	11.183	9	M14 x 40	170
C133E-500	5	5.000	7.087	7.441	1.339	1.614	2.165	2.717	14,314	68,706	27,230	19,212	11.183	9	M14 x 40	170
C133E-543	5 7/16	5.438	7.480	7.835	1.339	1.614	2.165	2.717	15,566	68,706	25,039	18,201	11.487	9	M14 x 40	170
C133E-593	5 15/16	5.938	7.874	8.228	1.339	1.614	2.165	2.717	18,886	76,340	25,478	19,212	12.425	10	M14 x 40	170
C133E-643	6 7/16	6.438	8.858	9.213	1.732	2.008	2.559	3.110	24,572	91,608	21,790	15,836	12.794	12	M14 x 40	170
C133E-693	6 15/16	6.938	9.252	9.606	1.732	2.008	2.559	3.110	26,480	91,608	20,220	15,162	13.137	12	M14 x 40	170
C133E-700	7	7.000	9.252	9.606	1.732	2.008	2.559	3.110	26,719	91,608	20,039	15,162	13.137	12	M14 x 40	170
C133E-743	7 7/16	7.438	9.843	10.197	1.732	2.008	2.559	3.110	35,486	114,510	23,576	17,815	14.961	15	M14 x 40	170
C133E-793	7 15/16	7.938	10.236	10.591	1.732	2.008	2.559	3.110	37,872	114,510	22,091	17,130	15.283	15	M14 x 40	170
C133E-800	8	8.000	10.236	10.591	1.732	2.008	2.559	3.110	38,170	114,510	21,918	17,130	15.283	15	M14 x 40	170

All dimensions are shown in inches unless stated otherwise. All dimensions and capacities are subject to change without notice.

* Minimum hub outside diameter based on a Pressure Reduction Factor of C=1.0 and hub material with tensile yield point ≥ 45,000 psi. For details refer to page 7.

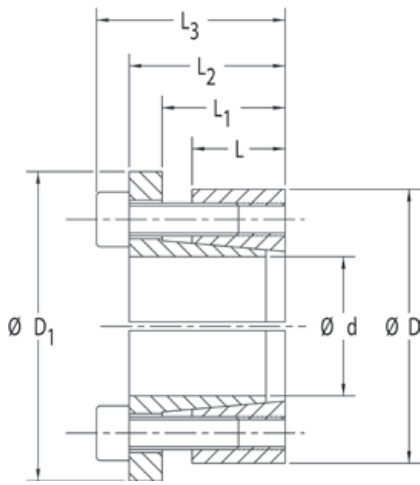

SERIES C133 LOCKING ASSEMBLY

- Single taper design with flange
- Excellent concentricity
- No axial movement of mounted component during installation



C133

Metric

Climax Part No.	Shaft Size (mm)	d	D	D ₁	L	L ₁	L ₂	L ₃	M _t (ft-lbs)	F _{ax} (lbs.F)	P _s (psi)	P _h (psi)	D _n *	Locking Screws		
														Qty.	Size	M _a [ft-lbs]
C133M- 14 x 28	14	0.551	1.102	1.260	0.551	0.669	0.807	0.965	50	2,191	19,127	9,564	1.368	4	M4 x 12	3.7
C133M- 15 x 28	15	0.591	1.102	1.260	0.551	0.669	0.807	0.965	54	2,191	17,852	9,564	1.368	4	M4 x 12	3.7
C133M- 16 x 32	16	0.630	1.260	1.457	0.551	0.709	0.846	1.004	57	2,191	16,736	8,368	1.521	4	M4 x 12	3.7
C133M- 18 x 47	18	0.709	1.850	2.047	0.669	0.886	1.122	1.358	185	6,265	35,037	13,418	2.517	5	M6 x 20	13
C133M- 19 x 47	19	0.748	1.850	2.047	0.669	0.886	1.122	1.358	195	6,265	33,193	13,418	2.517	5	M6 x 20	13
C133M- 20 x 47	20	0.787	1.850	2.047	0.669	0.886	1.122	1.358	206	6,265	31,533	13,418	2.517	5	M6 x 20	13
C133M- 22 x 47	22	0.866	1.850	2.047	0.669	0.886	1.122	1.358	226	6,265	28,667	13,418	2.517	5	M6 x 20	13
C133M- 24 x 50	24	0.945	1.969	2.224	0.669	0.886	1.122	1.358	296	7,518	31,533	15,136	2.793	6	M6 x 20	13
C133M- 25 x 50	25	0.984	1.969	2.224	0.669	0.886	1.122	1.358	308	7,518	30,272	15,136	2.793	6	M6 x 20	13
C133M- 28 x 55	28	1.102	2.165	2.421	0.669	0.886	1.122	1.358	345	7,518	27,028	13,760	2.970	6	M6 x 20	13
C133M- 30 x 55	30	1.181	2.165	2.421	0.669	0.886	1.122	1.358	370	7,518	25,227	13,760	2.970	6	M6 x 20	13
C133M- 32 x 60	32	1.260	2.362	2.618	0.669	0.886	1.122	1.358	526	10,024	31,533	16,818	3.499	8	M6 x 20	13
C133M- 35 x 60	35	1.378	2.362	2.618	0.669	0.886	1.122	1.358	576	10,024	28,830	16,818	3.499	8	M6 x 20	13
C133M- 38 x 65	38	1.496	2.559	2.815	0.669	0.886	1.122	1.358	625	10,024	26,554	15,524	3.667	8	M6 x 20	13
C133M- 40 x 65	40	1.575	2.559	2.815	0.669	0.886	1.122	1.358	658	10,024	25,227	15,524	3.667	8	M6 x 20	13
C133M- 42 x 75	42	1.654	2.953	3.287	0.787	1.043	1.358	1.673	1,117	16,206	33,016	18,489	4.569	7	M8 x 25	30
C133M- 45 x 75	45	1.772	2.953	3.287	0.787	1.043	1.358	1.673	1,196	16,206	30,815	18,489	4.569	7	M8 x 25	30
C133M- 48 x 80	48	1.890	3.150	3.484	0.787	1.043	1.358	1.673	1,276	16,206	28,889	17,333	4.728	7	M8 x 25	30
C133M- 50 x 80	50	1.969	3.150	3.484	0.787	1.043	1.358	1.673	1,329	16,206	27,733	17,333	4.728	7	M8 x 25	30
C133M- 55 x 85	55	2.165	3.346	3.681	0.787	1.043	1.358	1.673	1,671	18,521	28,814	18,644	5.200	8	M8 x 25	30
C133M- 60 x 90	60	2.362	3.543	3.858	0.787	1.043	1.358	1.673	1,823	18,521	26,413	17,608	5.357	8	M8 x 25	30
C133M- 65 x 95	65	2.559	3.740	4.016	0.787	1.043	1.358	1.673	2,222	20,836	27,429	18,767	5.831	9	M8 x 25	30
C133M- 70 x 110	70	2.756	4.331	4.685	0.945	1.201	1.594	1.988	3,491	30,403	30,970	19,708	6.927	8	M10 x 30	61
C133M- 75 x 115	75	2.953	4.528	4.882	0.945	1.201	1.594	1.988	3,741	30,403	28,906	18,852	7.075	8	M10 x 30	61
C133M- 80 x 120	80	3.150	4.724	5.079	0.945	1.201	1.594	1.988	3,990	30,403	27,099	18,066	7.229	8	M10 x 30	61
C133M- 85 x 125	85	3.346	4.921	5.276	0.945	1.201	1.594	1.988	4,769	34,204	28,693	19,511	7.829	9	M10 x 30	61
C133M- 90 x 130	90	3.543	5.118	5.472	0.945	1.201	1.594	1.988	5,050	34,204	27,099	18,761	7.978	9	M10 x 30	61
C133M- 95 x 135	95	3.740	5.315	5.669	0.945	1.201	1.594	1.988	5,923	38,004	28,525	20,073	8.588	10	M10 x 30	61
C133M- 100 x 145	100	3.937	5.709	6.063	1.024	1.299	1.772	2.244	7,448	45,406	29,886	20,611	9.363	8	M12 x 35	107
C133M- 110 x 155	110	4.331	6.102	6.457	1.024	1.299	1.772	2.244	8,193	45,406	27,169	19,281	9.648	8	M12 x 35	107
C133M- 120 x 165	120	4.724	6.496	6.850	1.024	1.299	1.772	2.244	10,055	51,081	28,018	20,377	10.585	9	M12 x 35	107
C133M- 130 x 180	130	5.118	7.087	7.441	1.339	1.614	2.165	2.717	14,652	68,706	26,602	19,212	11.183	9	M14 x 40	170
C133M- 140 x 190	140	5.512	7.480	7.835	1.339	1.614	2.165	2.717	15,779	68,706	24,701	18,201	11.487	9	M14 x 40	170
C133M- 150 x 200	150	5.906	7.874	8.228	1.339	1.614	2.165	2.717	18,784	76,340	25,616	19,212	12.425	10	M14 x 40	170
C133M- 160 x 210	160	6.299	8.268	8.622	1.339	1.614	2.165	2.717	22,040	83,974	26,417	20,127	13.378	11	M14 x 40	170
C133M- 170 x 225	170	6.693	8.858	9.213	1.732	2.008	2.559	3.110	25,547	91,608	20,959	15,836	12.794	12	M14 x 40	170
C133M- 180 x 235	180	7.087	9.252	9.606	1.732	2.008	2.559	3.110	27,050	91,608	19,794	15,162	13.137	12	M14 x 40	170
C133M- 190 x 250	190	7.480	9.843	10.197	1.732	2.008	2.559	3.110	35,690	114,510	23,441	17,815	14.961	15	M14 x 40	170
C133M- 200 x 260	200	7.874	10.236	10.591	1.732	2.008	2.559	3.110	37,569	114,510	22,269	17,130	15.283	15	M14 x 40	170
C133M- 220 x 285	220	8.661	11.220	11.496	1.969	2.244	2.874	3.504	45,638	126,459	19,674	15,187	15.943	12	M16 x 45	262
C133M- 240 x 305	240	9.449	12.008	12.362	1.969	2.244	2.874	3.504	62,234	158,073	22,543	17,739	18.216	15	M16 x 45	262
C133M- 260 x 325	260	10.236	12.795	13.150	1.969	2.244	2.874	3.504	80,904	189,688	24,971	19,977	20.618	18	M16 x 45	262
C133M- 280 x 355	280	11.024	13.976	14.331	2.362	2.638	3.346	4.055	92,692	201,803	20,557	16,214	20.381	16	M18 x 50	358
C133M- 300 x 375	300	11.811	14.764	15.118	2.362	2.638	3.346	4.055	111,726	227,028	21,585	17,268	22.123	18	M18 x 50	358

All dimensions are shown in inches unless stated otherwise. All dimensions and capacities are subject to change without notice.

* Minimum hub outside diameter based on a Pressure Reduction Factor of C=1.0 and hub material with tensile yield point \geq 45,000 psi. For details refer to page 7.



SERIES C123 LOCKING ASSEMBLY

- Single taper design
- Flangeless design mounts flush inside component bore
- Mounted component moves axially during installation

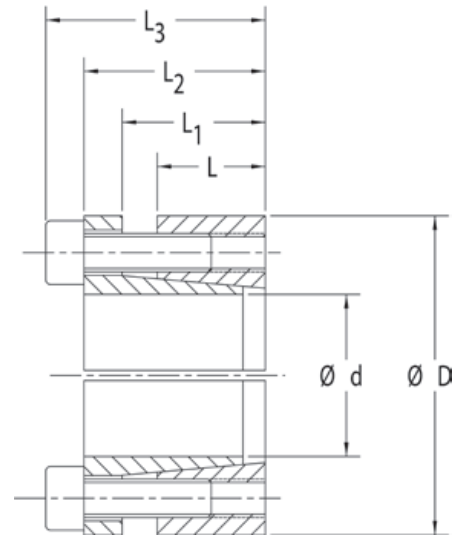

Inch

Climax Part No.	Shaft Size (in)			Dimensions (in)				M _t (ft-lbs)	F _{ax} (lbs.F)	P _s (psi)	P _h (psi)	D _n *	Locking Screws		
	Size (in)	d	D	L	L ₁	L ₂	L ₃						Qty.	Size	M _a [ft-lbs]
C123E-075	3/4	0.750	1.850	0.669	0.886	1.122	1.358	196	6,265	33,106	13,418	2.517	5	M6 x 20	10
C123E-087	7/8	0.875	1.850	0.669	0.886	1.122	1.358	228	6,265	28,376	13,418	2.517	5	M6 x 20	10
C123E-100	1	1.000	1.969	0.669	0.886	1.122	1.358	313	7,518	29,795	15,136	2.793	6	M6 x 20	10
C123E-112	1 1/8	1.125	2.165	0.669	0.886	1.122	1.358	352	7,518	26,485	13,760	2.970	6	M6 x 20	10
C123E-118	1 3/16	1.188	2.165	0.669	0.886	1.122	1.358	372	7,518	25,091	13,760	2.970	6	M6 x 20	10
C123E-125	1 1/4	1.250	2.362	0.669	0.886	1.122	1.358	522	10,024	31,781	16,818	3.499	8	M6 x 20	10
C123E-137	1 3/8	1.375	2.362	0.669	0.886	1.122	1.358	574	10,024	28,892	16,818	3.499	8	M6 x 20	10
C123E-143	1 7/16	1.438	2.559	0.669	0.886	1.122	1.358	600	10,024	27,636	15,524	3.667	8	M6 x 20	10
C123E-150	1 1/2	1.500	2.559	0.669	0.886	1.122	1.358	626	10,024	26,485	15,524	3.667	8	M6 x 20	10
C123E-162	1 5/8	1.625	2.953	0.787	1.043	1.358	1.673	1,097	16,206	33,596	18,489	4.569	7	M8 x 25	26
C123E-168	1 11/16	1.688	2.953	0.787	1.043	1.358	1.673	1,139	16,206	32,351	18,489	4.569	7	M8 x 25	26
C123E-175	1 3/4	1.750	2.953	0.787	1.043	1.358	1.673	1,182	16,206	31,196	18,489	4.569	7	M8 x 25	26
C123E-187	1 7/8	1.875	3.150	0.787	1.043	1.358	1.673	1,266	16,206	29,116	17,333	4.728	7	M8 x 25	26
C123E-193	1 15/16	1.938	3.150	0.787	1.043	1.358	1.673	1,308	16,206	28,177	17,333	4.728	7	M8 x 25	26
C123E-200	2	2.000	3.150	0.787	1.043	1.358	1.673	1,350	16,206	27,297	17,333	4.728	7	M8 x 25	26
C123E-212	2 1/8	2.125	3.346	0.787	1.043	1.358	1.673	1,640	18,521	29,361	18,644	5.200	8	M8 x 25	26
C123E-218	2 3/16	2.188	3.346	0.787	1.043	1.358	1.673	1,688	18,521	28,522	18,644	5.200	8	M8 x 25	26
C123E-225	2 1/4	2.250	3.543	0.787	1.043	1.358	1.673	1,736	18,521	27,730	17,608	5.357	8	M8 x 25	26
C123E-237	2 3/8	2.375	3.543	0.787	1.043	1.358	1.673	1,833	18,521	26,270	17,608	5.357	8	M8 x 25	26
C123E-243	2 7/16	2.438	3.740	0.787	1.043	1.358	1.673	2,116	20,836	28,796	18,767	5.831	9	M8 x 25	26
C123E-250	2 1/2	2.500	3.740	0.787	1.043	1.358	1.673	2,170	20,836	28,076	18,767	5.831	9	M8 x 25	26
C123E-256	2 9/16	2.563	3.740	0.787	1.043	1.358	1.673	2,225	20,836	27,392	18,767	5.831	9	M8 x 25	26
C123E-268	2 11/16	2.688	4.331	0.945	1.201	1.594	1.988	3,405	30,403	31,759	19,708	6.927	8	M10 x 30	51
C123E-275	2 3/4	2.750	4.331	0.945	1.201	1.594	1.988	3,484	30,403	31,037	19,708	6.927	8	M10 x 30	51
C123E-287	2 7/8	2.875	4.528	0.945	1.201	1.594	1.988	3,642	30,403	29,687	18,852	7.075	8	M10 x 30	51
C123E-293	2 15/16	2.938	4.528	0.945	1.201	1.594	1.988	3,721	30,403	29,056	18,852	7.075	8	M10 x 30	51
C123E-300	3	3.000	4.724	0.945	1.201	1.594	1.988	3,800	30,403	28,450	18,066	7.229	8	M10 x 30	51
C123E-325	3 1/4	3.250	4.921	0.945	1.201	1.594	1.988	4,632	34,204	29,545	19,511	7.829	9	M10 x 30	51
C123E-337	3 3/8	3.375	4.921	0.945	1.201	1.594	1.988	4,810	34,204	28,450	19,511	7.829	9	M10 x 30	51
C123E-343	3 7/16	3.438	5.118	0.945	1.201	1.594	1.988	4,899	34,204	27,933	18,761	7.978	9	M10 x 30	51
C123E-350	3 1/2	3.500	5.118	0.945	1.201	1.594	1.988	4,988	34,204	27,434	18,761	7.978	9	M10 x 30	51
C123E-375	3 3/4	3.750	5.315	0.945	1.201	1.594	1.988	5,938	38,004	28,450	20,073	8.588	10	M10 x 30	51
C123E-393	3 15/16	3.938	5.709	1.024	1.299	1.772	2.244	7,449	45,406	29,883	20,611	9.363	8	M12 x 35	89
C123E-400	4	4.000	5.709	1.024	1.299	1.772	2.244	7,568	45,406	29,416	20,611	9.363	8	M12 x 35	89
C123E-443	4 7/16	4.438	6.102	1.024	1.299	1.772	2.244	8,395	45,406	26,516	19,281	9.648	8	M12 x 35	89
C123E-475	4 3/4	4.750	6.496	1.024	1.299	1.772	2.244	10,110	51,081	27,867	20,377	10.585	9	M12 x 35	89
C123E-493	4 15/16	4.938	7.087	1.339	1.614	2.165	2.717	14,135	68,706	27,575	19,212	11.183	9	M14 x 40	140
C123E-500	5	5.000	7.087	1.339	1.614	2.165	2.717	14,314	68,706	27,230	19,212	11.183	9	M14 x 40	140
C123E-543	5 7/16	5.438	7.480	1.339	1.614	2.165	2.717	15,566	68,706	25,039	18,201	11.487	9	M14 x 40	140
C123E-593	5 15/16	5.938	7.874	1.339	1.614	2.165	2.717	18,886	76,340	25,478	19,212	12.425	10	M14 x 40	140
C123E-643	6 7/16	6.438	8.858	1.732	2.008	2.559	3.110	24,572	91,608	21,790	15,836	12.794	12	M14 x 40	140
C123E-693	6 15/16	6.938	9.252	1.732	2.008	2.559	3.110	26,480	91,608	20,220	15,162	13.137	12	M14 x 40	140
C123E-700	7	7.000	9.252	1.732	2.008	2.559	3.110	26,719	91,608	20,039	15,162	13.137	12	M14 x 40	140
C123E-743	7 7/16	7.438	9.843	1.732	2.008	2.559	3.110	35,486	114,510	23,576	17,815	14.961	15	M14 x 40	140
C123E-793	7 15/16	7.938	10.236	1.732	2.008	2.559	3.110	37,872	114,510	22,091	17,130	15.283	15	M14 x 40	140
C123E-800	8	8.000	10.236	1.732	2.008	2.559	3.110	38,170	114,510	21,918	17,130	15.283	15	M14 x 40	140

All dimensions are shown in inches unless stated otherwise. All dimensions and capacities are subject to change without notice.

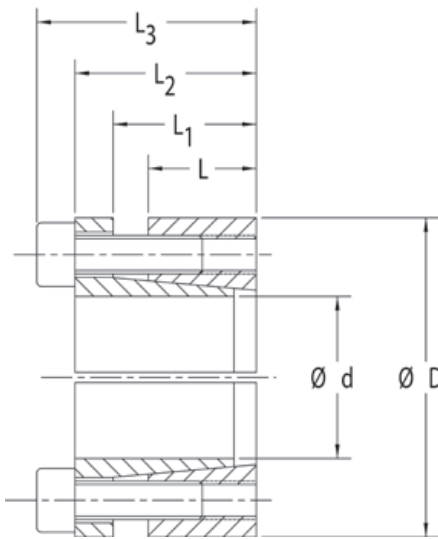

SERIES C123 LOCKING ASSEMBLY

- Single taper design
- Flangeless design mounts flush inside component bore
- Mounted component moves axially during installation



C123

Metric

Climax Part No.	Shaft Size (mm)	d	D	L	L ₁	L ₂	L ₃	M _t (ft.-lbs)	F _{ax} (lbs.F)	P _s (psi)	P _h (psi)	D _n *	Locking Screws		
													Qty.	Size	M _a [ft.-lbs]
C123M- 14 x 32	14	0.551	1.260	0.551	0.709	0.846	1.004	50	2,191	19,127	8,368	1.521	4	M4 x 12	3
C123M- 15 x 32	15	0.591	1.260	0.551	0.709	0.846	1.004	54	2,191	17,852	8,368	1.521	4	M4 x 12	3
C123M- 16 x 32	16	0.630	1.260	0.551	0.709	0.846	1.004	57	2,191	16,736	8,368	1.521	4	M4 x 12	3
C123M- 18 x 47	18	0.709	1.850	0.669	0.886	1.122	1.358	185	6,265	35,037	13,418	2.517	5	M6 x 20	10
C123M- 19 x 47	19	0.748	1.850	0.669	0.886	1.122	1.358	195	6,265	33,193	13,418	2.517	5	M6 x 20	10
C123M- 20 x 47	20	0.787	1.850	0.669	0.886	1.122	1.358	206	6,265	31,533	13,418	2.517	5	M6 x 20	10
C123M- 22 x 47	22	0.866	1.850	0.669	0.886	1.122	1.358	226	6,265	28,667	13,418	2.517	5	M6 x 20	10
C123M- 24 x 50	24	0.945	1.969	0.669	0.886	1.122	1.358	296	7,518	31,533	15,136	2.793	6	M6 x 20	10
C123M- 25 x 50	25	0.984	1.969	0.669	0.886	1.122	1.358	308	7,518	30,272	15,136	2.793	6	M6 x 20	10
C123M- 28 x 55	28	1.102	2.165	0.669	0.886	1.122	1.358	345	7,518	27,028	13,760	2.970	6	M6 x 20	10
C123M- 30 x 55	30	1.181	2.165	0.669	0.886	1.122	1.358	370	7,518	25,227	13,760	2.970	6	M6 x 20	10
C123M- 32 x 60	32	1.260	2.362	0.669	0.886	1.122	1.358	526	10,024	31,533	16,818	3.499	8	M6 x 20	10
C123M- 35 x 60	35	1.378	2.362	0.669	0.886	1.122	1.358	576	10,024	28,830	16,818	3.499	8	M6 x 20	10
C123M- 38 x 65	38	1.496	2.559	0.669	0.886	1.122	1.358	625	10,024	26,554	15,524	3.667	8	M6 x 20	10
C123M- 40 x 65	40	1.575	2.559	0.669	0.886	1.122	1.358	658	10,024	25,227	15,524	3.667	8	M6 x 20	10
C123M- 42 x 75	42	1.654	2.953	0.787	1.043	1.358	1.673	1,117	16,206	33,016	18,489	4.569	7	M8 x 25	26
C123M- 45 x 75	45	1.772	2.953	0.787	1.043	1.358	1.673	1,196	16,206	30,815	18,489	4.569	7	M8 x 25	26
C123M- 48 x 80	48	1.890	3.150	0.787	1.043	1.358	1.673	1,276	16,206	28,889	17,333	4.728	7	M8 x 25	26
C123M- 50 x 80	50	1.969	3.150	0.787	1.043	1.358	1.673	1,329	16,206	27,733	17,333	4.728	7	M8 x 25	26
C123M- 55 x 85	55	2.165	3.346	0.787	1.043	1.358	1.673	1,671	18,521	28,814	18,644	5.200	8	M8 x 25	26
C123M- 60 x 90	60	2.362	3.543	0.787	1.043	1.358	1.673	1,823	18,521	26,413	17,608	5.357	8	M8 x 25	26
C123M- 65 x 95	65	2.559	3.740	0.787	1.043	1.358	1.673	2,222	20,836	27,429	18,767	5.831	9	M8 x 25	26
C123M- 70 x 110	70	2.756	4.331	0.945	1.201	1.594	1.988	3,491	30,403	30,970	19,708	6.927	8	M10 x 30	51
C123M- 75 x 115	75	2.953	4.528	0.945	1.201	1.594	1.988	3,741	30,403	28,906	18,852	7.075	8	M10 x 30	51
C123M- 80 x 120	80	3.150	4.724	0.945	1.201	1.594	1.988	3,990	30,403	27,099	18,066	7.229	8	M10 x 30	51
C123M- 85 x 125	85	3.346	4.921	0.945	1.201	1.594	1.988	4,769	34,204	28,693	19,511	7.829	9	M10 x 30	51
C123M- 90 x 130	90	3.543	5.118	0.945	1.201	1.594	1.988	5,050	34,204	27,099	18,761	7.978	9	M10 x 30	51
C123M- 95 x 135	95	3.740	5.315	0.945	1.201	1.594	1.988	5,923	38,004	28,525	20,073	8.588	10	M10 x 30	51
C123M- 100 x 145	100	3.937	5.709	1.024	1.299	1.772	2.244	7,448	45,406	29,886	20,611	9.363	8	M12 x 35	89
C123M- 110 x 155	110	4.331	6.102	1.024	1.299	1.772	2.244	8,193	45,406	27,169	19,281	9.648	8	M12 x 35	89
C123M- 120 x 165	120	4.724	6.496	1.024	1.299	1.772	2.244	10,055	51,081	28,018	20,377	10.585	9	M12 x 35	89
C123M- 130 x 180	130	5.118	7.087	1.339	1.614	2.165	2.717	14,652	68,706	26,602	19,212	11.183	9	M14 x 40	140
C123M- 140 x 190	140	5.512	7.480	1.339	1.614	2.165	2.717	15,779	68,706	24,701	18,201	11.487	9	M14 x 40	140
C123M- 150 x 200	150	5.906	7.874	1.339	1.614	2.165	2.717	18,784	76,340	25,616	19,212	12.425	10	M14 x 40	140
C123M- 160 x 210	160	6.299	8.268	1.339	1.614	2.165	2.717	22,040	83,974	26,417	20,127	13.378	11	M14 x 40	140
C123M- 170 x 225	170	6.693	8.858	1.732	2.008	2.559	3.110	25,547	91,608	20,959	15,836	12.794	12	M14 x 40	140
C123M- 180 x 235	180	7.087	9.252	1.732	2.008	2.559	3.110	27,050	91,608	19,794	15,162	13.137	12	M14 x 40	140
C123M- 190 x 250	190	7.480	9.843	1.732	2.008	2.559	3.110	35,690	114,510	23,441	17,815	14.961	15	M14 x 40	140
C123M- 200 x 260	200	7.874	10.236	1.732	2.008	2.559	3.110	37,569	114,510	22,269	17,130	15.283	15	M14 x 40	140
C123M- 220 x 285	220	8.661	11.220	1.969	2.244	2.874	3.504	45,638	126,459	19,674	15,187	15.943	12	M16 x 45	218
C123M- 240 x 305	240	9.449	12.008	1.969	2.244	2.874	3.504	62,234	158,073	22,543	17,739	18.216	15	M16 x 45	218
C123M- 260 x 325	260	10.236	12.795	1.969	2.244	2.874	3.504	80,904	189,688	24,971	19,977	20.618	18	M16 x 45	218
C123M- 280 x 355	280	11.024	13.976	2.362	2.638	3.346	4.055	92,692	201,803	20,557	16,214	20.381	16	M18 x 50	299
C123M- 300 x 375	300	11.811	14.764	2.362	2.638	3.346	4.055	111,726	227,028	21,585	17,268	22.123	18	M18 x 50	299

All dimensions are shown in inches unless stated otherwise. All dimensions and capacities are subject to change without notice.

* Minimum hub outside diameter based on a Pressure Reduction Factor of C=1.0 and hub material with tensile yield point \geq 45,000 psi. For details refer to page 7.



SERIES C200 LOCKING ASSEMBLY

- Original double taper, self-releasing design
- First-generation device; not self-centering
- No axial movement of mounted component during installation

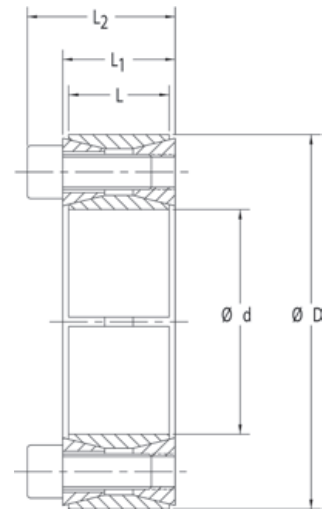

Inch

Climax Part No.	Shaft Size (in)			Dimensions (in)			M _t (ft-lbs)	F _{ax} (lbs.F)	P _s (psi)	P _h (psi)	D _n *	Locking Screws			
	Size	d	D	L	L ₁	L ₂						Qty.	Size	M _a (ft-lbs)	dB
C200E-075	3/4	0.750	1.850	0.669	0.787	1.024	223	7,135	37,704	15,282	2.635	8	M6 x 18	10	M8
C200E-087	7/8	0.875	1.850	0.669	0.787	1.024	260	7,135	32,318	15,282	2.635	8	M6 x 18	10	M8
C200E-100	1	1.000	1.969	0.669	0.787	1.024	334	8,027	31,813	16,161	2.867	9	M6 x 18	10	M8
C200E-112	1 1/8	1.125	2.165	0.669	0.787	1.024	418	8,919	31,420	16,324	3.167	10	M6 x 18	10	M8
C200E-118	1 3/16	1.188	2.159	0.669	0.787	1.024	441	8,919	29,766	16,372	3.161	10	M6 x 18	10	M8
C200E-125	1 1/4	1.250	2.362	0.669	0.787	1.024	557	10,703	33,934	17,957	3.604	12	M6 x 18	10	M8
C200E-137	1 3/8	1.375	2.365	0.669	0.787	1.024	613	10,703	30,849	17,936	3.606	12	M6 x 18	10	M8
C200E-143	1 7/16	1.438	2.559	0.669	0.787	1.024	748	12,486	34,425	19,338	4.052	14	M6 x 18	10	M8
C200E-150	1 1/2	1.500	2.559	0.669	0.787	1.024	780	12,486	32,991	19,338	4.052	14	M6 x 18	10	M8
C200E-162	1 5/8	1.625	2.953	0.787	0.945	1.260	1,334	19,706	40,853	22,483	5.112	12	M8 x 22	26	M10
C200E-168	1 11/16	1.688	2.953	0.787	0.945	1.260	1,386	19,706	39,340	22,483	5.112	12	M8 x 22	26	M10
C200E-175	1 3/4	1.750	2.953	0.787	0.945	1.260	1,437	19,706	37,935	22,483	5.112	12	M8 x 22	26	M10
C200E-187	1 7/8	1.875	3.150	0.787	0.945	1.260	1,540	19,706	35,406	21,078	5.235	12	M8 x 22	26	M10
C200E-193	1 15/16	1.938	3.150	0.787	0.945	1.260	1,591	19,706	34,264	21,078	5.235	12	M8 x 22	26	M10
C200E-200	2	2.000	3.346	0.787	0.945	1.260	1,916	22,991	38,725	23,144	5.909	14	M8 x 22	26	M10
C200E-212	2 1/8	2.125	3.346	0.787	0.945	1.260	2,036	22,991	36,447	23,144	5.909	14	M8 x 22	26	M10
C200E-218	2 3/16	2.188	3.543	0.787	0.945	1.260	2,095	22,991	35,406	21,858	6.023	14	M8 x 22	26	M10
C200E-225	2 1/4	2.250	3.543	0.787	0.945	1.260	2,155	22,991	34,422	21,858	6.023	14	M8 x 22	26	M10
C200E-237	2 3/8	2.375	3.531	0.787	0.945	1.260	2,275	22,991	32,611	21,934	6.015	14	M8 x 22	26	M10
C200E-243	2 7/16	2.438	3.740	0.787	0.945	1.260	2,669	26,275	36,314	23,666	6.710	16	M8 x 22	26	M10
C200E-250	2 1/2	2.500	3.740	0.787	0.945	1.260	2,737	26,275	35,406	23,666	6.710	16	M8 x 22	26	M10
C200E-256	2 9/16	2.563	3.737	0.787	0.945	1.260	2,805	26,275	34,542	23,686	6.708	16	M8 x 22	26	M10
C200E-262	2 5/8	2.625	4.331	0.945	1.102	1.496	4,000	36,569	39,109	23,705	7.779	14	M10 x 25	51	M12
C200E-268	2 11/16	2.688	4.331	0.945	1.102	1.496	4,095	36,569	38,199	23,705	7.779	14	M10 x 25	51	M12
C200E-275	2 3/4	2.750	4.337	0.945	1.102	1.496	4,190	36,569	37,331	23,671	7.782	14	M10 x 25	51	M12
C200E-287	2 7/8	2.875	4.528	0.945	1.102	1.496	4,381	36,569	35,708	22,675	7.883	14	M10 x 25	51	M12
C200E-293	2 15/16	2.938	4.528	0.945	1.102	1.496	4,476	36,569	34,948	22,675	7.883	14	M10 x 25	51	M12
C200E-300	3	3.000	4.724	0.945	1.102	1.496	4,571	36,569	34,220	21,730	8.000	14	M10 x 25	51	M12
C200E-312	3 1/8	3.125	4.724	0.945	1.102	1.496	4,762	36,569	32,852	21,730	8.000	14	M10 x 25	51	M12
C200E-325	3 1/4	3.250	4.921	0.945	1.102	1.496	5,660	41,793	36,101	23,841	8.877	16	M10 x 25	51	M12
C200E-337	3 3/8	3.375	4.921	0.945	1.102	1.496	5,877	41,793	34,764	23,841	8.877	16	M10 x 25	51	M12
C200E-343	3 7/16	3.438	5.118	0.945	1.102	1.496	5,986	41,793	34,131	22,924	8.978	16	M10 x 25	51	M12
C200E-350	3 1/2	3.500	5.118	0.945	1.102	1.496	6,095	41,793	33,522	22,924	8.978	16	M10 x 25	51	M12
C200E-375	3 3/4	3.750	5.305	0.945	1.102	1.496	7,346	47,017	35,198	24,880	9.887	18	M10 x 25	51	M12
C200E-387	3 7/8	3.875	5.709	1.024	1.299	1.772	8,640	53,513	35,786	24,291	10.442	14	M12 x 30	89	M14
C200E-393	3 15/16	3.938	5.709	1.024	1.299	1.772	8,779	53,513	35,218	24,291	10.442	14	M12 x 30	89	M14
C200E-400	4	4.000	5.843	1.024	1.299	1.772	8,919	53,513	34,668	23,733	10.504	14	M12 x 30	89	M14
C200E-418	4 3/16	4.188	6.102	1.024	1.299	1.772	9,337	53,513	33,115	22,724	10.640	14	M12 x 30	89	M14
C200E-443	4 7/16	4.438	6.496	1.024	1.299	1.772	11,308	61,157	35,714	24,396	11.922	16	M12 x 30	89	M14
C200E-450	4 1/2	4.500	6.496	1.024	1.299	1.772	11,467	61,157	35,218	24,396	11.922	16	M12 x 30	89	M14
C200E-493	4 15/16	4.938	7.087	1.339	1.496	1.969	15,727	76,446	30,681	21,377	11.879	20	M12 x 35	89	M14
C200E-500	5	5.000	7.087	1.339	1.496	1.969	15,926	76,446	30,298	21,377	11.879	20	M12 x 35	89	M14
C200E-543	5 7/16	5.438	7.480	1.339	1.496	1.969	19,052	84,091	30,646	22,277	12.871	22	M12 x 35	89	M14
C200E-550	5 1/2	5.500	7.492	1.339	1.496	1.969	19,271	84,091	30,298	22,242	12.878	22	M12 x 35	89	M14
C200E-600	6	6.000	8.268	1.339	1.496	1.969	24,845	99,380	32,823	23,820	14.903	26	M12 x 35	89	M14
C200E-643	6 7/16	6.438	8.858	1.496	1.732	2.283	30,910	115,236	31,739	23,065	15.604	22	M14 x 40	140	M16
C200E-650	6 1/2	6.500	8.858	1.496	1.732	2.283	31,210	115,236	31,434	23,065	15.604	22	M14 x 40	140	M16
C200E-693	6 15/16	6.938	9.252	1.496	1.732	2.283	36,339	125,712	32,129	24,091	16.818	24	M14 x 40	140	M16
C200E-700	7	7.000	9.252	1.496	1.732	2.283	36,666	125,712	31,842	24,091	16.818	24	M14 x 40	140	M16
C200E-750	7 1/2	7.500	9.823	1.811	2.047	2.598	45,833	146,664	28,642	21,869	16.701	28	M14 x 45	140	M16
C200E-787	7 7/8	7.875	10.236	1.811	2.047	2.598	51,562	157,140	29,227	22,485	17.722	30	M14 x 45	140	M16
C200E-793	7 15/16	7.938	10.504	1.811	2.047	2.598	51,971	157,140	28,997	21,912	17.882	30	M14 x 45	140	M16
C200E-800	8	8.000	10.504	1.811	2.047	2.598	52,380	157,140	28,770	21,912	17.882	30	M14 x 45	140	M16

All dimensions are shown in inches unless stated otherwise. All dimensions and capacities are subject to change without notice.

* Minimum hub outside diameter based on a Pressure Reduction Factor of C=1.0 and hub material with tensile yield point ≥ 45,000 psi. For details refer to page 7.

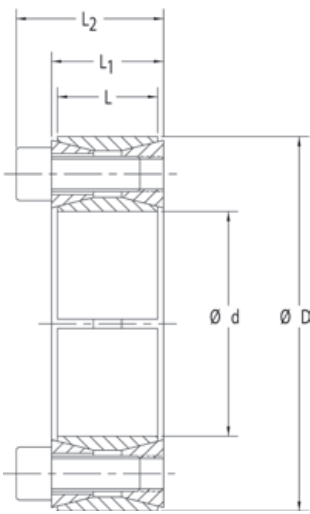

SERIES C200 LOCKING ASSEMBLY

- Original double taper, self-releasing design
- First-generation device; not self-centering
- No axial movement of mounted component during installation



C200

Metric

Climax Part No.	Shaft Size (mm)		Dimensions (mm)				M _t (ft-lbs)	F _{ax} (lbs.F)	P _s (psi)	P _h (psi)	D _n *	Locking Screws			
	d	D	L	L ₁	L ₂	Qty.						Size	M _a (ft-lbs)	dB	
C200M- 18 x 47	18	0.709	1.850	0.669	0.787	1.024	211	7,135	39,903	15,282	2.635	8	M6 x 18	10	M8
C200M- 19 x 47	19	0.748	1.850	0.669	0.787	1.024	222	7,135	37,803	15,282	2.635	8	M6 x 18	10	M8
C200M- 20 x 47	20	0.787	1.850	0.669	0.787	1.024	234	7,135	35,913	15,282	2.635	8	M6 x 18	10	M8
C200M- 22 x 47	22	0.866	1.850	0.669	0.787	1.024	257	7,135	32,648	15,282	2.635	8	M6 x 18	10	M8
C200M- 24 x 50	24	0.945	1.969	0.669	0.787	1.024	316	8,027	33,668	16,161	2.867	9	M6 x 18	10	M8
C200M- 25 x 50	25	0.984	1.969	0.669	0.787	1.024	329	8,027	32,322	16,161	2.867	9	M6 x 18	10	M8
C200M- 28 x 55	28	1.102	2.165	0.669	0.787	1.024	410	8,919	32,065	16,324	3.167	10	M6 x 18	10	M8
C200M- 30 x 55	30	1.181	2.165	0.669	0.787	1.024	439	8,919	29,928	16,324	3.167	10	M6 x 18	10	M8
C200M- 32 x 60	32	1.260	2.362	0.669	0.787	1.024	562	10,703	33,668	17,957	3.604	12	M6 x 18	10	M8
C200M- 35 x 60	35	1.378	2.362	0.669	0.787	1.024	614	10,703	30,783	17,957	3.604	12	M6 x 18	10	M8
C200M- 38 x 65	38	1.496	2.559	0.669	0.787	1.024	778	12,486	33,078	19,338	4.052	14	M6 x 18	10	M8
C200M- 40 x 65	40	1.575	2.559	0.669	0.787	1.024	819	12,486	31,424	19,338	4.052	14	M6 x 18	10	M8
C200M- 42 x 75	42	1.654	2.953	0.787	0.945	1.260	1,358	19,706	40,148	22,483	5.112	12	M8 x 22	26	M10
C200M- 45 x 75	45	1.772	2.953	0.787	0.945	1.260	1,455	19,706	37,471	22,483	5.112	12	M8 x 22	26	M10
C200M- 48 x 80	48	1.890	3.150	0.787	0.945	1.260	1,552	19,706	35,129	21,078	5.235	12	M8 x 22	26	M10
C200M- 50 x 80	50	1.969	3.150	0.787	0.945	1.260	1,616	19,706	33,724	21,078	5.235	12	M8 x 22	26	M10
C200M- 55 x 85	55	2.165	3.346	0.787	0.945	1.260	2,074	22,991	35,768	23,144	5.909	14	M8 x 22	26	M10
C200M- 60 x 90	60	2.362	3.543	0.787	0.945	1.260	2,263	22,991	32,787	21,858	6.023	14	M8 x 22	26	M10
C200M- 65 x 95	65	2.559	3.740	0.787	0.945	1.260	2,802	26,275	34,589	23,666	6.710	16	M8 x 22	26	M10
C200M- 70 x 110	70	2.756	4.331	0.945	1.102	1.496	4,199	36,569	37,251	23,705	7.779	14	M10 x 25	51	M12
C200M- 75 x 115	75	2.953	4.528	0.945	1.102	1.496	4,499	36,569	34,768	22,675	7.883	14	M10 x 25	51	M12
C200M- 80 x 120	80	3.150	4.724	0.945	1.102	1.496	4,799	36,569	32,595	21,730	8.000	14	M10 x 25	51	M12
C200M- 85 x 125	85	3.346	4.921	0.945	1.102	1.496	5,827	41,793	35,060	23,841	8.877	16	M10 x 25	51	M12
C200M- 90 x 130	90	3.543	5.118	0.945	1.102	1.496	6,170	41,793	33,112	22,924	8.978	16	M10 x 25	51	M12
C200M- 95 x 135	95	3.740	5.315	0.945	1.102	1.496	7,327	47,017	35,291	24,834	9.891	18	M10 x 25	51	M12
C200M- 100 x 145	100	3.937	5.709	1.024	1.299	1.772	8,778	53,513	35,222	24,291	10.442	14	M12 x 30	89	M14
C200M- 110 x 155	110	4.331	6.102	1.024	1.299	1.772	9,656	53,513	32,020	22,724	10.640	14	M12 x 30	89	M14
C200M- 120 x 165	120	4.724	6.496	1.024	1.299	1.772	12,039	61,157	33,545	24,396	11.922	16	M12 x 30	89	M14
C200M- 130 x 180	130	5.118	7.087	1.339	1.496	1.969	16,303	76,446	29,599	21,377	11.879	20	M12 x 35	89	M14
C200M- 140 x 190	140	5.512	7.480	1.339	1.496	1.969	19,312	84,091	30,233	22,277	12.871	22	M12 x 35	89	M14
C200M- 150 x 200	150	5.906	7.874	1.339	1.496	1.969	22,573	91,736	30,783	23,087	13.880	24	M12 x 35	89	M14
C200M- 160 x 210	160	6.299	8.268	1.339	1.496	1.969	26,084	99,380	31,264	23,820	14.903	26	M12 x 35	89	M14
C200M- 170 x 225	170	6.693	8.858	1.496	1.732	2.283	32,136	115,236	30,528	23,065	15.604	22	M14 x 40	140	M16
C200M- 180 x 235	180	7.087	9.252	1.496	1.732	2.283	37,120	125,712	31,453	24,091	16.818	24	M14 x 40	140	M16
C200M- 190 x 250	190	7.480	9.843	1.811	2.047	2.598	45,712	146,664	28,718	21,825	16.714	28	M14 x 45	140	M16
C200M- 200 x 260	200	7.874	10.236	1.811	2.047	2.598	51,555	157,140	29,230	22,485	17.722	30	M14 x 45	140	M16
C200M- 220 x 285	220	8.661	11.220	1.969	2.205	2.835	67,746	187,719	29,205	22,544	19.460	26	M16 x 50	218	M20
C200M- 240 x 305	240	9.449	12.008	1.969	2.205	2.835	85,275	216,598	30,889	24,306	21.975	30	M16 x 50	218	M20
C200M- 260 x 325	260	10.236	12.795	1.969	2.205	2.835	104,699	245,478	32,315	25,852	24.613	34	M16 x 50	218	M20
C200M- 280 x 355	280	11.024	13.976	2.362	2.598	3.307	129,009	280,870	28,611	22,566	24.256	32	M18 x 60	299	M22
C200M- 300 x 375	300	11.811	14.764	2.362	2.598	3.307	155,501	315,979	30,042	24,033	26.789	36	M18 x 60	299	M22
C200M- 320 x 405	320	12.598	15.945	2.835	3.071	3.858	214,023	407,715	30,284	23,928	28.838	36	M20 x 70	428	M24
C200M- 340 x 425	340	13.386	16.732	2.835	3.071	3.858	227,400	407,715	28,502	22,802	29.243	36	M20 x 70	428	M24
C200M- 360 x 455	360	14.173	17.913	3.307	3.543	4.409	299,466	507,095	28,697	22,706	31.217	36	M22 x 80	575	M27
C200M- 380 x 475	380	14.961	18.701	3.307	3.543	4.409	316,103	507,095	27,187	21,750	31.686	36	M22 x 80	575	M27
C200M- 400 x 495	400	15.748	19.488	3.307	3.543	4.409	332,740	507,095	25,828	20,871	32.199	36	M22 x 80	575	M27

All dimensions are shown in inches unless stated otherwise. All dimensions and capacities are subject to change without notice.

* Minimum hub outside diameter based on a Pressure Reduction Factor of C=1.0 and hub material with tensile yield point ≥ 45,000 psi. For details refer to page 7.

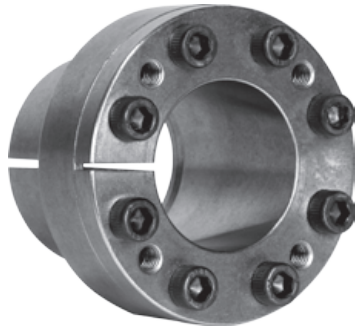

SERIES C170 LOCKING ASSEMBLY

- Single taper design with flange and integrated spacer
- Excellent concentricity
- Thin cross section accommodates smaller diameter mounted component

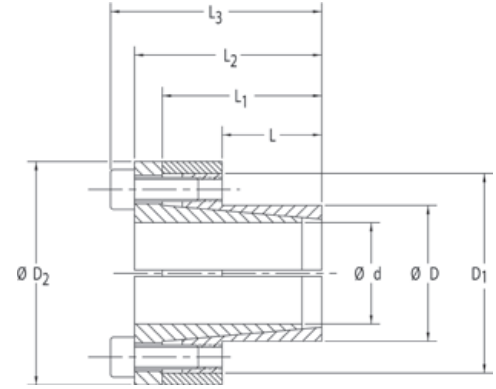

Inch

Climax Part No.	Shaft Size (in)	d	D	D ₁	D ₂	L	L ₁	L ₂	L ₃	M _t (ft-lbs)	F _{ax} (lbs.F)	P _s (psi)	P _h (psi)	D _n *	Locking Screws		
															Qty.	Size	M _a (ft-lbs)
C170E-025	1/4	0.250	0.551	0.906	0.984	0.394	0.748	0.866	1.024	17	1,643	44,278	20,083	0.891	3	M4 x 10	3.7
C170E-031	5/16	0.313	0.591	0.945	1.063	0.472	0.866	0.984	1.142	21	1,643	29,519	15,620	0.848	3	M4 x 10	3.7
C170E-037	3/8	0.375	0.630	1.024	1.142	0.551	0.945	1.063	1.220	34	2,191	28,113	16,736	0.931	4	M4 x 10	3.7
C170E-043	7/16	0.438	0.709	1.102	1.260	0.551	0.945	1.083	1.240	40	2,191	24,097	14,877	0.999	4	M4 x 10	3.7
C170E-050	1/2	0.500	0.906	1.299	1.496	0.551	0.945	1.083	1.240	46	2,191	21,085	11,643	1.180	4	M4 x 10	3.7
C170E-062	5/8	0.625	0.945	1.575	1.732	0.630	1.161	1.437	1.673	98	3,759	25,326	16,752	1.397	3	M6 x 16	13
C170E-075	3/4	0.750	1.063	1.693	1.929	0.709	1.280	1.555	1.791	157	5,012	25,013	17,648	1.609	4	M6 x 16	13
C170E-087	7/8	0.875	1.260	1.890	2.126	0.984	1.575	1.850	2.087	183	5,012	15,437	10,721	1.606	4	M6 x 16	13
C170E-093	15/16	0.938	1.339	1.969	2.205	0.984	1.575	1.850	2.087	294	7,518	21,611	15,136	1.899	6	M6 x 16	13
C170E-100	1	1.000	1.339	1.969	2.205	0.984	1.575	1.850	2.087	313	7,518	20,261	15,136	1.899	6	M6 x 16	13
C170E-112	1 1/8	1.125	1.535	2.165	2.402	0.984	1.575	1.850	2.087	352	7,518	18,009	13,195	2.077	6	M6 x 16	13
C170E-118	1 3/16	1.188	1.614	2.244	2.441	0.984	1.575	1.850	2.087	372	7,518	17,062	12,552	2.150	6	M6 x 16	13
C170E-125	1 1/4	1.250	1.693	2.323	2.559	0.984	1.575	1.850	2.087	522	10,024	21,611	15,957	2.453	8	M6 x 16	13
C170E-137	1 3/8	1.375	1.850	2.441	2.677	1.260	1.850	2.126	2.362	574	10,024	15,349	11,406	2.398	8	M6 x 18	13
C170E-143	1 7/16	1.438	1.969	2.598	2.835	1.260	1.850	2.126	2.362	600	10,024	14,682	10,721	2.510	8	M6 x 18	13
C170E-150	1 1/2	1.500	1.969	2.598	2.835	1.260	1.850	2.126	2.362	626	10,024	14,070	10,721	2.510	8	M6 x 18	13
C170E-162	1 5/8	1.625	2.165	2.795	3.071	1.260	1.850	2.126	2.362	679	10,024	12,988	9,747	2.698	8	M6 x 18	13
C170E-168	1 11/16	1.688	2.323	3.150	3.386	1.772	2.441	2.756	3.071	1,302	18,521	16,433	11,938	3.048	8	M8 x 22	30
C170E-175	1 3/4	1.750	2.323	3.150	3.386	1.772	2.441	2.756	3.071	1,350	18,521	15,846	11,938	3.048	8	M8 x 22	30
C170E-187	1 7/8	1.875	2.441	3.189	3.425	1.772	2.441	2.756	3.071	1,447	18,521	14,789	11,360	3.160	8	M8 x 22	30
C170E-193	1 15/16	1.938	2.559	3.386	3.622	1.772	2.441	2.756	3.071	1,495	18,521	14,312	10,836	3.272	8	M8 x 22	30
C170E-200	2	2.000	2.795	3.622	3.858	2.165	2.874	3.189	3.504	1,736	20,836	12,762	9,131	3.434	9	M8 x 22	30
C170E-212	2 1/8	2.125	2.795	3.622	3.858	2.165	2.874	3.189	3.504	1,845	20,836	12,011	9,131	3.434	9	M8 x 22	30
C170E-218	2 3/16	2.188	3.031	3.858	4.094	2.165	2.874	3.189	3.504	1,899	20,836	11,668	8,420	3.663	9	M8 x 22	30
C170E-237	2 3/8	2.375	3.031	3.858	4.094	2.165	2.874	3.189	3.504	2,062	20,836	10,747	8,420	3.663	9	M8 x 22	30
C170E-243	2 7/16	2.438	3.307	4.134	4.370	2.165	2.874	3.189	3.504	2,116	20,836	10,471	7,718	3.933	9	M8 x 22	30
C170E-250	2 1/2	2.500	3.307	4.134	4.370	2.165	2.874	3.189	3.504	2,170	20,836	10,210	7,718	3.933	9	M8 x 22	30
C170E-262	2 5/8	2.625	3.543	4.449	4.685	2.559	3.386	3.780	4.173	3,741	34,204	13,506	10,006	4.442	9	M10 x 25	61
C170E-275	2 3/4	2.750	3.543	4.449	4.685	2.559	3.386	3.780	4.173	3,919	34,204	12,892	10,006	4.442	9	M10 x 25	61
C170E-287	2 7/8	2.875	3.740	4.685	4.961	2.559	3.386	3.780	4.173	4,097	34,204	12,332	9,479	4.632	9	M10 x 25	61
C170E-293	2 15/16	2.938	3.740	4.685	4.961	2.559	3.386	3.780	4.173	4,186	34,204	12,069	9,479	4.632	9	M10 x 25	61
C170E-300	3	3.000	3.740	4.685	4.961	2.559	3.386	3.780	4.173	4,275	34,204	11,818	9,479	4.632	9	M10 x 25	61
C170E-312	3 1/8	3.125	3.937	4.921	5.157	2.559	3.386	3.780	4.173	5,938	45,605	15,127	12,007	5.175	12	M10 x 25	61
C170E-325	3 1/4	3.250	4.173	5.157	5.394	2.559	3.386	3.780	4.173	6,176	45,605	14,545	11,327	5.398	12	M10 x 25	61
C170E-337	3 3/8	3.375	4.173	5.157	5.394	2.559	3.386	3.780	4.173	6,413	45,605	14,006	11,327	5.398	12	M10 x 25	61
C170E-343	3 7/16	3.438	4.409	5.394	5.669	2.559	3.386	3.780	4.173	6,532	45,605	13,752	10,720	5.622	12	M10 x 25	61
C170E-350	3 1/2	3.500	4.409	5.394	5.669	2.559	3.386	3.780	4.173	6,651	45,605	13,506	10,720	5.622	12	M10 x 25	61
C170E-362	3 5/8	3.625	4.409	5.394	5.669	2.559	3.386	3.780	4.173	6,888	45,605	13,040	10,720	5.622	12	M10 x 25	61
C170E-375	3 3/4	3.750	4.724	5.591	5.866	2.559	3.386	3.780	4.173	8,313	53,206	14,707	11,673	6.161	14	M10 x 25	61
C170E-387	3 7/8	3.875	4.921	6.024	6.299	2.756	3.701	4.213	4.685	10,997	68,108	16,917	13,321	6.677	12	M12 x 30	107
C170E-393	3 15/16	3.938	4.921	6.024	6.299	2.756	3.701	4.213	4.685	11,174	68,108	16,649	13,321	6.677	12	M12 x 30	107
C170E-400	4	4.000	4.921	6.024	6.299	2.756	3.701	4.213	4.685	11,351	68,108	16,389	13,321	6.677	12	M12 x 30	107
C170E-425	4 1/4	4.250	5.512	6.614	6.850	2.756	3.701	4.213	4.685	12,061	68,108	15,425	11,894	7.226	12	M12 x 30	107
C170E-437	4 3/8	4.375	5.512	6.614	6.850	2.756	3.701	4.213	4.685	12,416	68,108	14,984	11,894	7.226	12	M12 x 30	107
C170E-443	4 7/16	4.438	6.102	7.362	7.795	3.543	4.528	5.039	5.512	16,791	90,811	15,320	11,140	7.858	16	M12 x 30	107
C170E-450	4 1/2	4.500	6.102	7.362	7.795	3.543	4.528	5.039	5.512	17,027	90,811	15,107	11,140	7.858	16	M12 x 30	107
C170E-475	4 3/4	4.750	6.102	7.362	7.795	3.543	4.528	5.039	5.512	17,973	90,811	14,312	11,140	7.858	16	M12 x 30	107
C170E-493	4 15/16	4.938	6.496	7.756	8.189	3.543	4.528	5.039	5.512	18,683	90,811	13,769	10,465	8.233	16	M12 x 30	107

All dimensions are shown in inches unless stated otherwise. All dimensions and capacities are subject to change without notice.

* Minimum hub outside diameter based on a Pressure Reduction Factor of C=1.0 and hub material with tensile yield point ≥ 45,000 psi. For details refer to page 7.

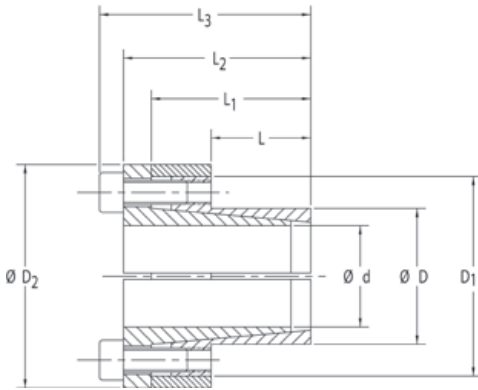

SERIES C170 LOCKING ASSEMBLY

- Single taper design with flange and integrated spacer
- Excellent concentricity
- Thin cross section accommodates smaller diameter mounted component

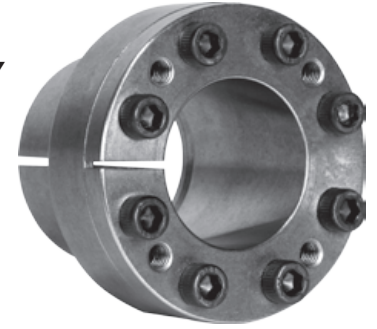

C170

Metric

Climax Part No.	Shaft Size (mm)	d	D	D ₁	D ₂	L	L ₁	L ₂	L ₃	M _t (ft-lbs)	F _{ax} (lbs.F)	P _s (psi)	P _h (psi)	D _n *	Locking Screws		
															Qty.	Size	M _a (ft-lbs)
C170M- 6 x 14	6	0.236	0.551	0.906	0.984	0.394	0.748	0.866	1.024	16	1,643	46,861	20,083	0.891	3	M4 x 10	3.7
C170M- 7 x 15	7	0.276	0.591	0.945	1.063	0.472	0.866	0.984	1.142	19	1,643	33,472	15,620	0.848	3	M4 x 10	3.7
C170M- 8 x 15	8	0.315	0.591	0.945	1.063	0.472	0.866	0.984	1.142	22	1,643	29,288	15,620	0.848	3	M4 x 10	3.7
C170M- 9 x 16	9	0.354	0.630	1.024	1.142	0.551	0.945	1.063	1.220	32	2,191	29,753	16,736	0.931	4	M4 x 10	3.7
C170M- 10 x 16	10	0.394	0.630	1.024	1.142	0.551	0.945	1.063	1.220	36	2,191	26,778	16,736	0.931	4	M4 x 10	3.7
C170M- 11 x 18	11	0.433	0.709	1.102	1.260	0.551	0.945	1.083	1.240	40	2,191	24,343	14,877	0.999	4	M4 x 10	3.7
C170M- 12 x 18	12	0.472	0.709	1.102	1.260	0.551	0.945	1.083	1.240	43	2,191	22,315	14,877	0.999	4	M4 x 10	3.7
C170M- 13 x 23	13	0.512	0.906	1.299	1.496	0.551	0.945	1.083	1.240	47	2,191	20,598	11,643	1.180	4	M4 x 10	3.7
C170M- 14 x 23	14	0.551	0.906	1.299	1.496	0.551	0.945	1.083	1.240	50	2,191	19,127	11,643	1.180	4	M4 x 10	3.7
C170M- 15 x 24	15	0.591	0.945	1.575	1.732	0.630	1.161	1.437	1.673	92	3,759	26,803	16,752	1.397	3	M6 x 16	13
C170M- 16 x 24	16	0.630	0.945	1.575	1.732	0.630	1.161	1.437	1.673	99	3,759	25,128	16,752	1.397	3	M6 x 16	13
C170M- 17 x 25	17	0.669	0.984	1.614	1.772	0.709	1.280	1.555	1.791	140	5,012	28,029	19,060	1.547	4	M6 x 16	13
C170M- 18 x 26	18	0.709	1.024	1.654	1.850	0.709	1.280	1.555	1.791	148	5,012	26,472	18,327	1.577	4	M6 x 16	13
C170M- 19 x 27	19	0.748	1.063	1.693	1.929	0.709	1.280	1.555	1.791	156	5,012	25,079	17,648	1.609	4	M6 x 16	13
C170M- 20 x 28	20	0.787	1.102	1.732	1.969	0.709	1.280	1.555	1.791	164	5,012	23,825	17,018	1.641	4	M6 x 16	13
C170M- 22 x 32	22	0.866	1.260	1.890	2.126	0.984	1.575	1.850	2.087	181	5,012	15,595	10,721	1.606	4	M6 x 16	13
C170M- 24 x 34	24	0.945	1.339	1.969	2.205	0.984	1.575	1.850	2.087	296	7,518	21,443	15,136	1.899	6	M6 x 16	13
C170M- 25 x 34	25	0.984	1.339	1.969	2.205	0.984	1.575	1.850	2.087	308	7,518	20,585	15,136	1.899	6	M6 x 16	13
C170M- 28 x 39	28	1.102	1.535	2.165	2.402	0.984	1.575	1.850	2.087	345	7,518	18,379	13,195	2.077	6	M6 x 16	13
C170M- 30 x 41	30	1.181	1.614	2.244	2.441	0.984	1.575	1.850	2.087	370	7,518	17,154	12,552	2.150	6	M6 x 16	13
C170M- 32 x 43	32	1.260	1.693	2.323	2.559	0.984	1.575	1.850	2.087	526	10,024	21,443	15,957	2.453	8	M6 x 16	13
C170M- 35 x 47	35	1.378	1.850	2.441	2.677	1.260	1.850	2.126	2.362	576	10,024	15,316	11,406	2.398	8	M6 x 18	13
C170M- 38 x 50	38	1.496	1.969	2.598	2.835	1.260	1.850	2.126	2.362	625	10,024	14,107	10,721	2.510	8	M6 x 18	13
C170M- 40 x 53	40	1.575	2.087	2.717	2.953	1.260	1.850	2.126	2.362	658	10,024	13,402	10,114	2.623	8	M6 x 18	13
C170M- 42 x 55	42	1.654	2.165	2.795	3.071	1.260	1.850	2.126	2.362	691	10,024	12,763	9,747	2.698	8	M6 x 18	13
C170M- 45 x 59	45	1.772	2.323	3.150	3.386	1.772	2.441	2.756	3.071	1,367	18,521	15,652	11,938	3.048	8	M8 x 22	30
C170M- 48 x 62	48	1.890	2.441	3.189	3.425	1.772	2.441	2.756	3.071	1,458	18,521	14,674	11,360	3.160	8	M8 x 22	30
C170M- 50 x 65	50	1.969	2.559	3.386	3.622	1.772	2.441	2.756	3.071	1,519	18,521	14,087	10,836	3.272	8	M8 x 22	30
C170M- 55 x 71	55	2.165	2.795	3.622	3.858	2.165	2.874	3.189	3.504	1,880	20,836	11,787	9,131	3.434	9	M8 x 22	30
C170M- 60 x 77	60	2.362	3.031	3.858	4.094	2.165	2.874	3.189	3.504	2,051	20,836	10,805	8,420	3.663	9	M8 x 22	30
C170M- 65 x 84	65	2.559	3.307	4.134	4.370	2.165	2.874	3.189	3.504	2,222	20,836	9,974	7,718	3.933	9	M8 x 22	30
C170M- 70 x 90	70	2.756	3.543	4.449	4.685	2.559	3.386	3.780	4.173	3,928	34,204	12,865	10,006	4.442	9	M10 x 25	61
C170M- 75 x 95	75	2.953	3.740	4.685	4.961	2.559	3.386	3.780	4.173	4,208	34,204	12,007	9,479	4.632	9	M10 x 25	61
C170M- 80 x 100	80	3.150	3.937	4.921	5.157	2.559	3.386	3.780	4.173	5,985	45,605	15,009	12,007	5.175	12	M10 x 25	61
C170M- 85 x 106	85	3.346	4.173	5.157	5.394	2.559	3.386	3.780	4.173	6,359	45,605	14,126	11,327	5.398	12	M10 x 25	61
C170M- 90 x 112	90	3.543	4.409	5.394	5.669	2.559	3.386	3.780	4.173	6,733	45,605	13,341	10,720	5.622	12	M10 x 25	61
C170M- 95 x 120	95	3.740	4.724	5.591	5.866	2.559	3.386	3.780	4.173	8,292	53,206	14,745	11,673	6.161	14	M10 x 25	61
C170M- 100 x 125	100	3.937	4.921	6.024	6.299	2.756	3.701	4.213	4.685	11,173	68,108	16,651	13,321	6.677	12	M12 x 30	107
C170M- 110 x 140	110	4.331	5.512	6.614	6.850	2.756	3.701	4.213	4.685	12,290	68,108	15,137	11,894	7.226	12	M12 x 30	107
C170M- 120 x 155	120	4.724	6.102	7.362	7.795	3.543	4.528	5.039	5.512	17,876	90,811	14,390	11,140	7.858	16	M12 x 30	107
C170M- 130 x 165	130	5.118	6.496	7.756	8.189	3.543	4.528	5.039	5.512	19,366	90,811	13,283	10,465	8.233	16	M12 x 30	107

All dimensions are shown in inches unless stated otherwise. All dimensions and capacities are subject to change without notice.

* Minimum hub outside diameter based on a Pressure Reduction Factor of C=1.0 and hub material with tensile yield point ≥ 45,000 psi. For details refer to page 7.



SERIES C405 LOCKING ASSEMBLY

- Heavy duty
- Wider design transmits higher torque and bending moments
- Excellent concentricity; extremely robust for the most demanding applications

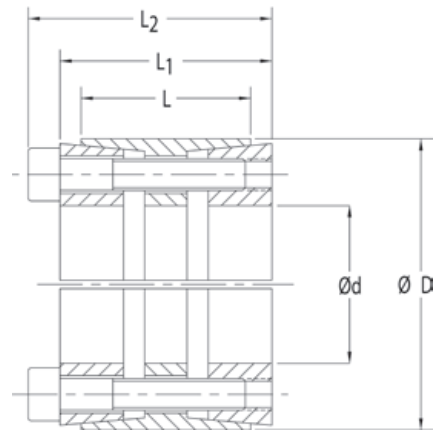

Inch

Climax Part No.	Shaft Size (in)	d	D	L	L ₁	L ₂	M _t (ft-lbs)	F _{ax} (lbs.F)	P _s (psi)	P _h (psi)	D _n *	Locking Screws		
												Qty.	Size	M _a (ft-lbs)
C405E-100	1	1.000	2.165	1.260	1.575	1.811	626	15,036	42,210	19,493	3.443	6	M6 x 35	13
C405E-112	1 1/8	1.125	2.165	1.260	1.575	1.811	705	15,036	37,520	19,493	3.443	6	M6 x 35	13
C405E-118	1 3/16	1.188	2.165	1.260	1.575	1.811	744	15,036	35,545	19,493	3.443	6	M6 x 35	13
C405E-125	1 1/4	1.250	2.362	1.732	2.126	2.362	914	17,542	27,809	14,715	3.317	7	M6 x 45	13
C405E-137	1 3/8	1.375	2.362	1.732	2.126	2.362	1,005	17,542	25,281	14,715	3.317	7	M6 x 45	13
C405E-143	1 7/16	1.438	2.362	1.732	2.126	2.362	1,051	17,542	24,182	14,715	3.317	7	M6 x 45	13
C405E-150	1 1/2	1.500	2.953	1.732	2.126	2.441	2,026	32,411	42,818	21,752	5.003	7	M8 x 45	30
C405E-162	1 5/8	1.625	2.953	1.732	2.126	2.441	2,195	32,411	39,524	21,752	5.003	7	M8 x 45	30
C405E-175	1 3/4	1.750	2.953	1.732	2.126	2.441	2,363	32,411	36,701	21,752	5.003	7	M8 x 45	30
C405E-187	1 7/8	1.875	3.150	2.205	2.598	2.913	2,894	37,041	30,251	18,009	4.812	8	M8 x 55	30
C405E-193	1 15/16	1.938	3.150	2.205	2.598	2.913	2,990	37,041	29,275	18,009	4.812	8	M8 x 55	30
C405E-200	2	2.000	3.150	2.205	2.598	2.913	3,087	37,041	28,360	18,009	4.812	8	M8 x 55	30
C405E-212	2 1/8	2.125	3.346	2.205	2.598	2.913	3,690	41,672	30,028	19,068	5.260	9	M8 x 55	30
C405E-218	2 3/16	2.188	3.346	2.205	2.598	2.913	3,798	41,672	29,170	19,068	5.260	9	M8 x 55	30
C405E-225	2 1/4	2.250	3.543	2.205	2.598	2.913	4,341	46,302	31,511	20,010	5.715	10	M8 x 55	30
C405E-237	2 3/8	2.375	3.543	2.205	2.598	2.913	4,582	46,302	29,853	20,010	5.715	10	M8 x 55	30
C405E-243	2 7/16	2.438	3.740	2.205	2.598	2.913	4,703	46,302	29,087	18,956	5.861	10	M8 x 55	30
C405E-250	2 1/2	2.500	3.740	2.205	2.598	2.913	4,823	46,302	28,360	18,956	5.861	10	M8 x 55	30
C405E-256	2 9/16	2.563	3.740	2.205	2.598	2.913	4,944	46,302	27,668	18,956	5.861	10	M8 x 55	30
C405E-262	2 5/8	2.625	4.331	2.756	3.150	3.543	8,313	76,008	34,837	21,116	7.205	10	M10 x 60	61
C405E-268	2 11/16	2.688	4.331	2.756	3.150	3.543	8,511	76,008	34,027	21,116	7.205	10	M10 x 60	61
C405E-275	2 3/4	2.750	4.331	2.756	3.150	3.543	8,709	76,008	33,254	21,116	7.205	10	M10 x 60	61
C405E-287	2 7/8	2.875	4.331	2.756	3.150	3.543	9,105	76,008	31,808	21,116	7.205	10	M10 x 60	61
C405E-293	2 15/16	2.938	4.724	2.756	3.150	3.543	10,233	83,609	34,244	21,292	7.900	11	M10 x 60	61
C405E-300	3	3.000	4.724	2.756	3.150	3.543	10,451	83,609	33,531	21,292	7.900	11	M10 x 60	61
C405E-312	3 1/8	3.125	4.724	2.756	3.150	3.543	10,887	83,609	32,190	21,292	7.900	11	M10 x 60	61
C405E-325	3 1/4	3.250	4.724	2.756	3.150	3.543	11,322	83,609	30,952	21,292	7.900	11	M10 x 60	61
C405E-337	3 3/8	3.375	5.118	2.756	3.150	3.543	12,826	91,209	32,515	21,441	8.595	12	M10 x 60	61
C405E-343	3 7/16	3.438	5.118	2.756	3.150	3.543	13,064	91,209	31,924	21,441	8.595	12	M10 x 60	61
C405E-350	3 1/2	3.500	5.118	2.756	3.150	3.543	13,301	91,209	31,354	21,441	8.595	12	M10 x 60	61
C405E-362	3 5/8	3.625	5.118	2.756	3.150	3.543	13,776	91,209	30,272	21,441	8.595	12	M10 x 60	61
C405E-375	3 3/4	3.750	5.709	3.543	4.016	4.488	19,510	124,865	32,049	21,053	9.481	11	M12 x 80	107
C405E-387	3 7/8	3.875	5.709	3.543	4.016	4.488	20,161	124,865	31,015	21,053	9.481	11	M12 x 80	107
C405E-393	3 15/16	3.938	5.709	3.543	4.016	4.488	20,486	124,865	30,523	21,053	9.481	11	M12 x 80	107
C405E-400	4	4.000	5.709	3.543	4.016	4.488	20,811	124,865	30,046	21,053	9.481	11	M12 x 80	107
C405E-425	4 1/4	4.250	6.102	3.543	4.016	4.488	24,122	136,217	30,849	21,485	10.261	12	M12 x 80	107
C405E-437	4 3/8	4.375	6.102	3.543	4.016	4.488	24,831	136,217	29,968	21,485	10.261	12	M12 x 80	107
C405E-443	4 7/16	4.438	6.496	3.543	4.016	4.488	29,384	158,920	34,470	23,547	11.612	14	M12 x 80	107
C405E-450	4 1/2	4.500	6.496	3.543	4.016	4.488	29,797	158,920	33,991	23,547	11.612	14	M12 x 80	107
C405E-475	4 3/4	4.750	6.496	3.543	4.016	4.488	31,453	158,920	32,202	23,547	11.612	14	M12 x 80	107
C405E-493	4 15/16	4.938	7.087	4.094	4.567	5.118	37,693	183,216	29,763	20,737	11.665	12	M14 x 90	170
C405E-500	5	5.000	7.087	4.094	4.567	5.118	38,170	183,216	29,391	20,737	11.665	12	M14 x 90	170
C405E-525	5 1/4	5.250	7.480	4.094	4.567	5.118	46,758	213,751	32,657	22,920	13.120	14	M14 x 90	170
C405E-543	5 7/16	5.438	7.480	4.094	4.567	5.118	48,428	213,751	31,531	22,920	13.120	14	M14 x 90	170
C405E-550	5 1/2	5.500	7.480	4.094	4.567	5.118	48,985	213,751	31,172	22,920	13.120	14	M14 x 90	170
C405E-575	5 3/4	5.750	7.874	4.094	4.567	5.118	54,869	229,019	31,947	23,329	13.982	15	M14 x 90	170
C405E-593	5 15/16	5.938	7.874	4.094	4.567	5.118	56,658	229,019	30,938	23,329	13.982	15	M14 x 90	170
C405E-600	6	6.000	8.268	4.094	4.567	5.118	61,072	244,287	32,657	23,699	14.848	16	M14 x 90	170
C405E-643	6 7/16	6.438	8.858	5.276	5.866	6.496	79,146	295,070	28,075	20,403	14.444	14	M16 x 110	262
C405E-650	6 1/2	6.500	8.858	5.276	5.866	6.496	79,915	295,070	27,805	20,403	14.444	14	M16 x 110	262
C405E-693	6 15/16	6.938	9.252	5.276	5.866	6.496	91,386	316,146	27,912	20,930	15.312	15	M16 x 110	262
C405E-700	7	7.000	9.252	5.276	5.866	6.496	92,209	316,146	27,663	20,930	15.312	15	M16 x 110	262
C405E-725	7 1/4	7.250	9.843	5.276	5.866	6.496	101,869	337,223	28,490	20,986	16.315	16	M16 x 110	262
C405E-743	7 7/16	7.438	9.843	5.276	5.866	6.496	104,504	337,223	27,772	20,986	16.315	16	M16 x 110	262
C405E-750	7 1/2	7.500	9.843	5.276	5.866	6.496	105,382	337,223	27,540	20,986	16.315	16	M16 x 110	262
C405E-775	7 3/4	7.750	10.236	5.276	5.866	6.496	108,895	337,223	26,652	20,178	16.587	16	M16 x 110	262
C405E-793	7 15/16	7.938	10.236	5.276	5.866	6.496	111,529	337,223	26,022	20,178	16.587	16	M16 x 110	262
C405E-800	8	8.000	10.236	5.276	5.866	6.496	112,408	337,223	25,819	20,178	16.587	16	M16 x 110	262

All dimensions are shown in inches unless stated otherwise. All dimensions and capacities are subject to change without notice.

* Minimum hub outside diameter based on a Pressure Reduction Factor of C=1.0 and hub material with tensile yield point ≥ 45,000 psi. For details refer to page 7.

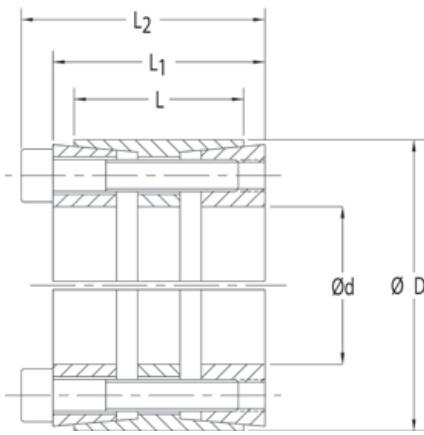

SERIES C405 LOCKING ASSEMBLY

- Heavy duty
- Wider design transmits higher torque and bending moments
- Excellent concentricity; extremely robust for the most demanding applications



C405

Metric

Climax Part No.	Shaft Size (mm)		L	L ₁	L ₂	M _t (ft-lbs)	F _{ax} (lbs.F)	P _s (psi)	P _h (psi)	D _n *	Locking Screws			
	d	D									Qty.	Size	M _a (ft-lbs)	
C405M- 24 x 55	24	0.945	2.165	1.260	1.575	1.811	592	15,036	67,008	29,240	4.700	6	M6 x 35	13
C405M- 25 x 55	25	0.984	2.165	1.260	1.575	1.811	617	15,036	42,885	19,493	3.443	6	M6 x 35	13
C405M- 28 x 55	28	1.102	2.165	1.260	1.575	1.811	691	15,036	38,290	19,493	3.443	6	M6 x 35	13
C405M- 30 x 55	30	1.181	2.165	1.260	1.575	1.811	740	15,036	35,738	19,493	3.443	6	M6 x 35	13
C405M- 32 x 60	32	1.260	2.362	1.732	2.126	2.362	921	17,542	27,592	14,715	3.317	7	M6 x 45	13
C405M- 35 x 60	35	1.378	2.362	1.732	2.126	2.362	1,007	17,542	25,227	14,715	3.317	7	M6 x 45	13
C405M- 38 x 75	38	1.496	2.953	1.732	2.126	2.441	2,020	32,411	42,931	21,752	5.003	7	M8 x 45	30
C405M- 40 x 75	40	1.575	2.953	1.732	2.126	2.441	2,127	32,411	40,784	21,752	5.003	7	M8 x 45	30
C405M- 42 x 75	42	1.654	2.953	1.732	2.126	2.441	2,233	32,411	38,842	21,752	5.003	7	M8 x 45	30
C405M- 45 x 75	45	1.772	2.953	1.732	2.126	2.441	2,393	32,411	36,253	21,752	5.003	7	M8 x 45	30
C405M- 48 x 80	48	1.890	3.150	2.205	2.598	2.913	2,917	37,041	30,014	18,009	4.812	8	M8 x 55	30
C405M- 50 x 80	50	1.969	3.150	2.205	2.598	2.913	3,038	37,041	28,814	18,009	4.812	8	M8 x 55	30
C405M- 55 x 85	55	2.165	3.346	2.205	2.598	2.913	3,760	41,672	29,469	19,068	5.260	9	M8 x 55	30
C405M- 60 x 90	60	2.362	3.543	2.205	2.598	2.913	4,557	46,302	30,014	20,010	5.715	10	M8 x 55	30
C405M- 65 x 95	65	2.559	3.740	2.205	2.598	2.913	4,937	46,302	27,706	18,956	5.861	10	M8 x 55	30
C405M- 70 x 110	70	2.756	4.331	2.756	3.150	3.543	8,728	76,008	33,182	21,116	7.205	10	M10 x 60	61
C405M- 80 x 120	80	3.150	4.724	2.756	3.150	3.543	10,972	83,609	31,938	21,292	7.900	11	M10 x 60	61
C405M- 90 x 130	90	3.543	5.118	2.756	3.150	3.543	13,466	91,209	30,970	21,441	8.595	12	M10 x 60	61
C405M- 100 x 145	100	3.937	5.709	3.543	4.016	4.488	20,483	124,865	30,527	21,053	9.481	11	M12 x 80	107
C405M- 110 x 155	110	4.331	6.102	3.543	4.016	4.488	24,580	136,217	30,274	21,485	10.261	12	M12 x 80	107
C405M- 120 x 165	120	4.724	6.496	3.543	4.016	4.488	31,283	158,920	32,377	23,547	11.612	14	M12 x 80	107
C405M- 130 x 180	130	5.118	7.087	4.094	4.567	5.118	39,072	183,216	28,713	20,737	11.665	12	M14 x 90	170
C405M- 140 x 190	140	5.512	7.480	4.094	4.567	5.118	49,090	213,751	31,106	22,920	13.120	14	M14 x 90	170
C405M- 150 x 200	150	5.906	7.874	4.094	4.567	5.118	56,353	229,019	31,106	23,329	13.982	15	M14 x 90	170
C405M- 160 x 210	160	6.299	8.268	4.094	4.567	5.118	64,117	244,287	31,106	23,699	14.848	16	M14 x 90	170
C405M- 170 x 225	170	6.693	8.858	5.276	5.866	6.496	82,287	295,070	27,003	20,403	14.444	14	M16 x 110	262
C405M- 180 x 235	180	7.087	9.252	5.276	5.866	6.496	93,350	316,146	27,325	20,930	15.312	15	M16 x 110	262
C405M- 190 x 250	190	7.480	9.843	5.276	5.866	6.496	105,106	337,223	27,613	20,986	16.315	16	M16 x 110	262
C405M- 200 x 260	200	7.874	10.236	5.276	5.866	6.496	110,637	337,223	26,232	20,178	16.587	16	M16 x 110	262
C405M- 220 x 285	220	8.661	11.220	5.276	5.906	6.535	136,914	379,376	26,828	20,709	18.455	18	M16 x 110	262
C405M- 240 x 305	240	9.449	12.008	5.276	5.906	6.535	165,956	421,529	27,325	21,502	20.201	20	M16 x 110	262
C405M- 260 x 325	260	10.236	12.795	5.276	5.906	6.535	188,775	442,605	26,484	21,187	21.332	21	M16 x 110	262
C405M- 280 x 355	280	11.024	13.976	6.496	6.969	7.756	270,299	588,480	27,248	21,491	23.505	18	M20 x 130	509
C405M- 300 x 375	300	11.811	14.764	6.496	6.969	7.756	321,785	653,867	28,257	22,606	25.652	20	M20 x 130	509
C405M- 320 x 405	320	12.598	15.945	6.496	6.969	7.756	360,399	686,560	27,816	21,978	27.197	21	M20 x 130	509
C405M- 340 x 425	340	13.386	16.732	6.496	6.969	7.756	401,159	719,254	27,426	21,941	28.509	22	M20 x 130	509
C405M- 360 x 455	360	14.173	17.913	7.480	7.992	8.858	502,181	850,359	26,595	21,042	29.741	21	M22 x 150	686
C405M- 380 x 475	380	14.961	18.701	7.480	7.992	8.858	555,321	890,852	26,395	21,116	31.114	22	M22 x 150	686
C405M- 400 x 495	400	15.748	19.488	7.480	7.992	8.858	637,690	971,839	27,354	22,105	33.364	24	M22 x 150	686

All dimensions are shown in inches unless stated otherwise. All dimensions and capacities are subject to change without notice.

* Minimum hub outside diameter based on a Pressure Reduction Factor of C=1.0 and hub material with tensile yield point ≥ 45,000 psi. For details refer to page 7.



SERIES C415 LOCKING ASSEMBLY

- Medium duty
- Wider design transmits higher torque and bending moments
- Excellent concentricity

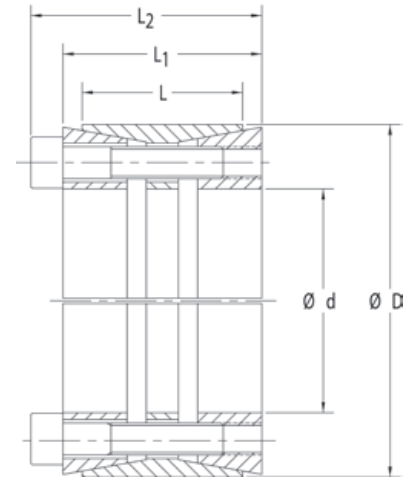

Inch

Climax Part No.	Shaft Size (in)	d	D	L	L ₁	L ₂	M _t (ft-lbs)	F _{ax} (lbs.F)	P _s (psi)	P _h (psi)	D _n *	Locking Screws		
												Qty.	Size	M _a (ft-lbs)
C415E-275	2 3/4	2.750	4.331	1.969	2.441	2.835	5,363	46,804	28,668	18,204	6.651	8	M10 x 50	61
C415E-293	2 15/16	2.938	4.528	1.969	2.441	2.835	5,729	46,804	26,838	17,413	6.810	8	M10 x 50	61
C415E-343	3 7/16	3.438	5.118	1.969	2.441	2.835	9,218	64,356	31,535	21,180	8.531	11	M10 x 50	61
C415E-350	3 1/2	3.500	5.118	1.969	2.441	2.835	9,385	64,356	30,971	21,180	8.531	11	M10 x 50	61
C415E-393	3 15/16	3.938	5.709	2.362	2.835	3.307	14,335	87,374	31,148	21,484	9.599	10	M12 x 60	107
C415E-443	4 7/16	4.438	6.496	2.362	2.835	3.307	17,771	96,112	30,402	20,768	10.702	11	M12 x 60	107
C415E-450	4 1/2	4.500	6.496	2.362	2.835	3.307	18,021	96,112	29,980	20,768	10.702	11	M12 x 60	107
C415E-493	4 15/16	4.938	7.087	2.559	3.189	3.661	25,166	122,324	30,911	21,537	11.934	14	M12 x 70	107
C415E-500	5	5.000	7.087	2.559	3.189	3.661	25,484	122,324	30,525	21,537	11.934	14	M12 x 70	107
C415E-543	5 7/16	5.438	7.480	2.559	3.228	3.701	29,694	131,062	30,074	21,861	12.715	15	M12 x 70	107
C415E-593	5 15/16	5.938	7.874	2.559	3.228	3.701	32,424	131,062	27,541	20,768	12.972	15	M12 x 70	107
C415E-600	6	6.000	8.268	2.559	3.228	3.701	34,950	139,799	29,071	21,097	13.748	16	M12 x 70	107
C415E-643	6 7/16	6.438	8.858	3.071	3.661	4.213	47,284	176,282	28,828	20,950	14.669	15	M14 x 80	170
C415E-693	6 15/16	6.938	9.252	3.071	3.661	4.213	50,956	176,282	26,750	20,058	14.943	15	M14 x 80	170
C415E-793	7 15/16	7.938	10.236	3.465	4.134	4.685	76,816	232,264	25,941	20,116	16.558	18	M14 x 80	170
C415E-800	8	8.000	10.236	3.465	4.134	4.685	77,421	232,264	25,738	20,116	16.558	18	M14 x 80	170

Metric

Climax Part No.	Shaft Size (mm)	d	D	L	L ₁	L ₂	M _t (ft-lbs)	F _{ax} (lbs.F)	P _s (psi)	P _h (psi)	D _n *	Locking Screws		
												Qty.	Size	M _a (ft-lbs)
C415M- 70 x 110	70	2.756	4.331	1.969	2.441	2.835	5,374	46,804	28,606	18,204	6.651	8	M10 x 50	61
C415M- 80 x 120	80	3.150	4.724	1.969	2.441	2.835	7,678	58,505	31,288	20,859	7.803	10	M10 x 50	61
C415M- 90 x 130	90	3.543	5.118	1.969	2.441	2.835	9,501	64,356	30,593	21,180	8.531	11	M10 x 50	61
C415M- 100 x 145	100	3.937	5.709	2.362	2.835	3.307	14,333	87,374	31,152	21,484	9.599	10	M12 x 60	107
C415M- 110 x 155	110	4.331	6.102	2.362	2.835	3.307	15,766	87,374	28,320	20,098	9.866	10	M12 x 60	107
C415M- 120 x 165	120	4.724	6.496	2.362	2.835	3.307	18,920	96,112	28,556	20,768	10.702	11	M12 x 60	107
C415M- 130 x 180	130	5.118	7.087	2.559	3.189	3.661	26,086	122,324	29,820	21,537	11.934	14	M12 x 70	107
C415M- 140 x 190	140	5.512	7.480	2.559	3.228	3.701	30,099	131,062	29,668	21,861	12.715	15	M12 x 70	107
C415M- 150 x 200	150	5.906	7.874	2.559	3.228	3.701	32,249	131,062	27,690	20,768	12.972	15	M12 x 70	107
C415M- 160 x 210	160	6.299	8.268	2.559	3.228	3.701	36,693	139,799	27,690	21,097	13.748	16	M12 x 70	107
C415M- 170 x 225	170	6.693	8.858	3.071	3.661	4.213	49,160	176,282	27,728	20,950	14.669	15	M14 x 80	170
C415M- 180 x 235	180	7.087	9.252	3.071	3.661	4.213	52,052	176,282	26,187	20,058	14.943	15	M14 x 80	170
C415M- 190 x 250	190	7.480	9.843	3.465	4.134	4.685	58,606	188,034	22,285	16,936	14.622	16	M14 x 80	170
C415M- 200 x 260	200	7.874	10.236	3.465	4.134	4.685	76,202	232,264	26,150	20,116	16.558	18	M14 x 80	170
C415M- 220 x 285	220	8.661	11.220	3.780	4.370	5.000	87,821	243,345	23,085	17,820	17.058	15	M16 x 90	262
C415M- 240 x 305	240	9.449	12.008	3.780	4.370	5.000	127,740	324,460	28,215	22,202	20.616	20	M16 x 90	262
C415M- 260 x 325	260	10.236	12.795	3.780	4.370	5.000	145,305	340,683	27,346	21,877	21.760	21	M16 x 90	262
C415M- 280 x 355	280	11.024	13.976	3.780	4.331	5.118	173,380	377,473	31,177	24,590	25.808	15	M20 x 90	509
C415M- 300 x 375	300	11.811	14.764	3.780	4.370	5.157	185,764	377,473	29,098	23,279	26.176	15	M20 x 90	509
C415M- 320 x 405	320	12.598	15.945	4.882	5.354	6.142	264,198	503,297	28,038	22,153	27.336	20	M20 x 110	509
C415M- 340 x 425	340	13.386	16.732	4.882	5.354	6.142	280,710	503,297	26,388	21,111	27.835	20	M20 x 110	509
C415M- 360 x 455	360	14.173	17.913	5.512	6.299	7.165	368,134	623,373	24,695	19,539	28.520	20	M22 x 130	686
C415M- 380 x 475	380	14.961	18.701	5.512	6.299	7.165	388,585	623,373	23,395	18,716	29.116	20	M22 x 130	686
C415M- 400 x 495	400	15.748	19.488	5.512	6.299	7.165	449,941	685,710	24,448	19,756	31.212	22	M22 x 130	686

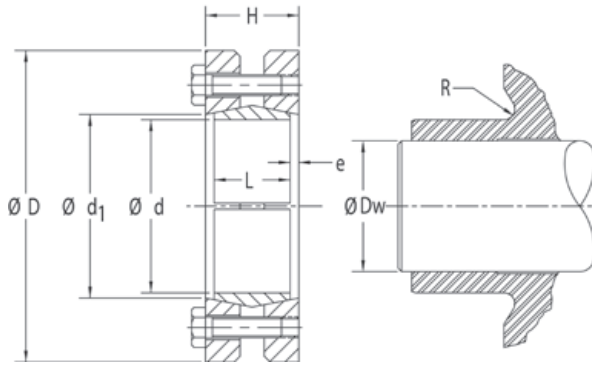

SERIES C733 SHRINK DISCS - STANDARD DUTY

- External keyless locking device
- Inherently balanced for high speed applications
- Preferred solution for coupling hubs and hollow shaft gearboxes



C733

Climax Part No.	d	d _{W-min}	d _{W-max}	M _t (ft-lbs) for		Locking Screws DIN 931 Grade 10.9			D	L	H	e	d ₁	R
				d _{W-min}	d _{W-max}	Qty.	Size	M _a (ft-lbs)						
C733M-14	0.551	0.375	0.451	22	55	3	M5 x 12	3	1.50	0.394	0.59	0.098	0.591	1/32
C733M-16	0.630	0.438	0.516	21	58	3	M5 x 16	3	1.61	0.472	0.67	0.098	0.669	1/32
C733M-18	0.709	0.500	0.581	52	99	4	M5 x 16	3	1.73	0.472	0.67	0.098	0.748	1/32
C733M-20	0.787	0.500	0.645	55	148	5	M5 x 16	3	1.81	0.472	0.67	0.098	0.866	1/32
C733M-24	0.945	0.625	0.774	97	215	6	M5 x 16	3	1.97	0.551	0.71	0.079	1.024	1/16
C733M-30	1.181	0.750	0.967	122	316	7	M5 x 18	3	2.36	0.630	0.79	0.079	1.260	1/16
C733M-36	1.417	0.875	1.161	319	675	5	M6 x 20	9	2.83	0.709	0.87	0.079	1.496	1/16
C733M-44	1.732	1.125	1.419	694	1,215	7	M6 x 20	9	3.15	0.787	0.94	0.079	1.850	1/16
C733M-50	1.969	1.375	1.613	981	1,590	8	M6 x 22	9	3.54	0.866	1.06	0.098	2.087	1/16
C733M-55	2.165	1.500	1.773	1,033	1,734	8	M6 x 25	9	3.94	0.906	1.14	0.118	2.283	3/32
C733M-62	2.441	1.750	1.999	1,746	2,412	10	M6 x 25	9	4.33	0.906	1.14	0.118	2.598	3/32
C733M-68	2.677	1.875	2.192	1,790	2,646	10	M6 x 25	9	4.53	0.906	1.14	0.118	2.835	3/32
C733M-75	2.953	2.125	2.419	2,808	4,079	7	M8 x 25	22	5.43	0.984	1.22	0.118	3.110	1/8
C733M-80	3.150	2.375	2.580	3,434	4,351	7	M8 x 25	22	5.71	0.984	1.22	0.118	3.307	1/8
C733M-90	3.543	2.500	2.902	4,779	7,175	10	M8 x 30	22	6.10	1.181	1.50	0.157	3.701	1/8
C733M-100	3.937	2.875	3.224	7,098	9,638	12	M8 x 35	22	6.69	1.339	1.69	0.177	4.094	1/8
C733M-110	4.331	3.125	3.547	8,873	12,421	9	M10 x 40	44	7.28	1.535	1.93	0.197	4.488	1/8
C733M-125	4.921	3.500	4.030	13,504	19,262	12	M10 x 40	44	8.46	1.654	2.09	0.217	5.276	1/8
C733M-140	5.512	4.000	4.514	19,544	26,310	10	M12 x 45	74	9.06	1.811	2.28	0.236	5.709	3/16
C733M-155	6.102	4.500	4.998	27,373	33,868	12	M12 x 50	74	10.35	1.969	2.44	0.236	6.496	3/16
C733M-165	6.496	4.875	5.320	37,488	46,845	8	M16 x 55	184	11.42	2.205	2.68	0.236	6.890	3/16
C733M-175	6.890	5.250	5.643	41,345	49,685	8	M16 x 55	184	11.81	2.205	2.68	0.236	7.283	3/16
C733M-185	7.283	5.625	5.965	56,439	65,556	10	M16 x 65	184	12.99	2.795	3.35	0.276	7.677	3/16
C733M-195	7.677	5.875	6.287	71,453	84,390	12	M16 x 65	184	13.78	2.795	3.35	0.276	8.110	3/16
C733M-200	7.874	6.250	6.449	80,170	86,554	12	M16 x 65	184	13.78	2.795	3.35	0.276	8.110	3/16
C733M-220	8.661	6.375	7.093	91,639	115,673	15	M16 x 80	184	14.57	3.465	4.09	0.315	8.898	1/4
C733M-240	9.449	7.000	7.739	130,071	161,101	12	M20 x 80	361	15.94	3.622	4.25	0.315	9.764	1/4
C733M-250	9.843	7.625	8.061	171,219	196,549	14	M20 x 90	361	16.93	4.055	4.69	0.315	10.551	1/4
C733M-260	10.236	8.000	8.383	182,023	204,411	14	M20 x 90	361	16.93	4.055	4.69	0.315	10.551	1/4
C733M-280	11.024	8.375	9.029	209,637	252,319	16	M20 x 100	361	18.11	4.488	5.20	0.354	11.339	5/16
C733M-300	11.811	9.000	9.673	256,148	305,461	18	M20 x 100	361	19.09	4.803	5.51	0.354	12.126	5/16
C733M-320	12.598	9.625	10.318	309,159	358,190	20	M20 x 100	361	20.47	4.803	5.51	0.354	12.913	5/16
C733M-340	13.386	10.250	10.963	389,653	459,821	24	M20 x 110	361	22.44	5.354	6.14	0.394	13.701	5/16
C733M-350	13.780	10.875	11.286	430,771	472,106	24	M20 x 110	361	22.83	5.512	6.30	0.394	14.488	5/16
C733M-360	14.173	11.250	11.608	449,446	485,595	24	M20 x 110	361	23.23	5.512	6.30	0.394	14.488	5/16
C733M-380	14.961	11.500	12.253	534,647	622,638	20	M24 x 120	620	25.39	5.669	6.46	0.394	15.276	5/16

Shaft Diameter d _W (inches)		T _W = Max. Diametrical Clearance Between Shaft and Hub Bore
Over	To and Including	
	1 1/8	0.0010
1 1/8	1 15/16	0.0015
1 15/16	4 3/4	0.0020
4 3/4	7	0.0030
7	10	0.0040
10	14	0.0050
14		0.0060

All dimensions are shown in inches unless stated otherwise. All dimensions and capacities are subject to change without notice. Climax Series C732 Heavy Duty Shrink Disc are available. Please contact Climax for more information.



SERIES C600 KEYLESS RIGID COUPLINGS

- Cost effective shaft-to-shaft keyless connection
- High torque and bending moment capacity
- Preferred solution for torque-arm mounted hydraulic drives
- Available with stepped bore upon request

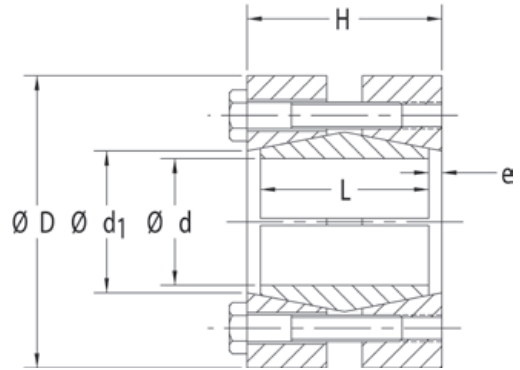

Inch

Climax Part No.	Type	Shaft Size (in)	d	M _t (ft-lbs)						Locking Screws		
					D	H	L	e	d ₁	Qty.	Size	M _a (ft-lbs)
C600E-062	15	5/8	0.625	167	2.047	1.339	1.181	0.079	0.827	3	M6 x 30	9
C600E-068		11/16	0.69	184								
C600E-075		3/4	0.750	200								
C600E-081	20	13/16	0.8125	362	2.362	1.575	1.339	0.118	1.024	5	M6 x 35	9
C600E-087		7/8	0.875	390								
C600E-093		15/16	0.9375	418								
C600E-100	25	1	1.000	624	2.598	1.732	1.496	0.118	1.260	7	M6 x 35	9
C600E-106		1 1/16	1.0625	662								
C600E-112		1 1/8	1.125	701								
C600E-118	30	1 3/16	1.1875	846	2.992	1.890	1.654	0.118	1.496	8	M6 x 40	9
C600E-125		1 1/4	1.250	891								
C600E-137		1 3/8	1.375	980								
C600E-143	40	1 7/16	1.4375	1,721	3.780	2.205	1.969	0.118	1.850	7	M8 x 45	22
C600E-150		1 1/2	1.500	1,796								
C600E-162		1 5/8	1.625	1,946								
C600E-168		1 11/16	1.6875	2,021								
C600E-175		1 3/4	1.750	2,095								
C600E-187	50	1 7/8	1.875	3,207	4.409	2.676	2.362	0.157	2.283	10	M8 x 50	22
C600E-193		1 15/16	1.9375	3,314								
C600E-200		2	2.000	3,421								
C600E-212		2 1/8	2.125	3,635								
C600E-218	60	2 3/16	2.1875	4,490	4.724	3.071	2.756	0.157	2.598	12	M8 x 55	22
C600E-225		2 1/4	2.250	4,618								
C600E-237		2 3/8	2.375	4,875								
C600E-243		2 7/16	2.4375	5,003								
C600E-250		2 1/2	2.500	5,132								
C600E-256	70	2 9/16	2.5625	8,197	5.826	3.464	3.150	0.157	3.110	12	M10 x 65	44
C600E-262		2 5/8	2.625	8,397								
C600E-268		2 11/16	2.6875	8,597								
C600E-275		2 3/4	2.750	8,797								
C600E-287		2 7/8	2.875	9,197								
C600E-293	80	2 15/16	2.9375	11,357	6.693	4.095	3.701	0.197	3.701	10	M12 x 80	74
C600E-300		3	3.000	11,599								
C600E-312		3 1/8	3.125	12,082								
C600E-325		3 1/4	3.250	12,566								
C600E-337		3 3/8	3.375	13,049								
C600E-343	90	3 7/16	3.4375	15,949	7.283	4.567	4.173	0.197	4.094	12	M12 x 80	74
C600E-350		3 1/2	3.500	16,239								
C600E-362		3 5/8	3.625	16,819								
C600E-375		3 3/4	3.750	17,399								
C600E-387		3 7/8	3.875	17,979								
C600E-393	100	3 15/16	3.9375	22,836	7.756	4.960	4.488	0.236	4.488	15	M12 x 90	74
C600E-400		4	4.000	23,198								
C600E-425		4 1/4	4.250	24,648								

All dimensions are shown in inches unless stated otherwise. All dimensions and capacities are subject to change without notice.

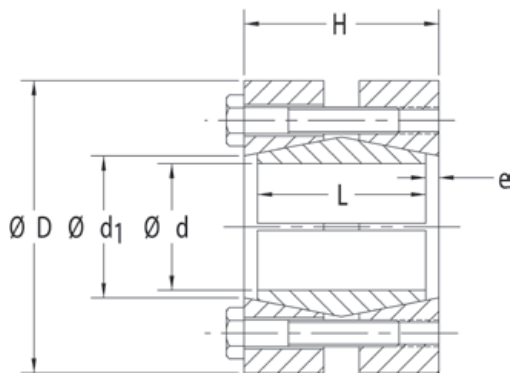

SERIES C600 KEYLESS RIGID COUPLINGS



METAL PRODUCTS COMPANY

www.climaxmetal.com ISO 9001:2008

- Cost effective shaft-to-shaft keyless connection
- High torque and bending moment capacity
- Preferred solution for torque-arm mounted hydraulic drives
- Available with stepped bore upon request



C600

Metric

Climax Part No.	Type	Shaft Size (mm)	d	M _t (ft-lbs)						Locking Screws		
					D	H	L	e	d ₁	Qty.	Size	M _a (ft-lbs)
C600M-6	6	6	0.236	34	1.38	0.748	0.630	0.060	0.394	4	M5 x 16	3
C600M-7		7	0.276	40								
C600M-8		8	0.315	46								
C600M-9	9	9	0.354	64	1.54	0.906	0.787	0.060	0.512	5	M5 x 20	3
C600M-10		10	0.394	71								
C600M-11		11	0.433	78								
C600M-12	12	12	0.472	102	1.73	1.181	1.024	0.079	0.630	6	M5 x 25	3
C600M-13		13	0.512	111								
C600M-14		14	0.551	120								
C600M-15	15	15	0.591	158	2.047	1.339	1.181	0.079	0.827	3	M6 x 30	9
C600M-16		16	0.630	168								
C600M-17		17	0.669	179								
C600M-18		18	0.709	189								
C600M-19		19	0.748	200								
C600M-20	20	20	0.787	351	2.362	1.575	1.339	0.118	1.024	5	M6 x 35	9
C600M-22		22	0.866	386								
C600M-24		24	0.945	421								
C600M-25	25	25	0.984	614	2.598	1.732	1.496	0.118	1.260	7	M6 x 35	9
C600M-28		28	1.102	687								
C600M-29		29	1.142	712								
C600M-30	30	30	1.181	842	2.992	1.890	1.654	0.118	1.496	8	M6 x 40	9
C600M-32		32	1.260	898								
C600M-35		35	1.378	982								
C600M-36	40	36	1.417	1,697	3.780	2.205	1.969	0.118	1.850	7	M8 x 45	22
C600M-40		40	1.575	1,886								
C600M-44		44	1.732	2,074								
C600M-50	50	50	1.969	3,367	4.409	2.676	2.362	0.157	2.283	10	M8 x 50	22
C600M-51		51	2.008	3,434								
C600M-54		54	2.126	3,637								
C600M-55	60	55	2.165	4,445	4.724	3.071	2.756	0.157	2.598	12	M8 x 55	22
C600M-60		60	2.362	4,849								
C600M-63		63	2.480	5,091								
C600M-65	70	65	2.559	8,186	5.826	3.464	3.150	0.157	3.110	12	M10 x 65	44
C600M-68		68	2.677	8,564								
C600M-70		70	2.756	8,816								
C600M-73		73	2.874	9,194								
C600M-74	80	74	2.913	11,264	6.693	4.095	3.701	0.197	3.701	10	M12 x 80	74
C600M-76		76	2.992	11,569								
C600M-80		80	3.150	12,178								
C600M-85		85	3.346	12,939								
C600M-86	90	86	3.386	15,709	7.283	4.567	4.173	0.197	4.094	12	M12 x 80	74
C600M-90		90	3.543	16,440								
C600M-92		92	3.622	16,805								
C600M-96		96	3.780	17,536								
C600M-100	100	100	3.937	22,833	7.756	4.960	4.488	0.236	4.488	15	M12 x 90	74
C600M-106		106	4.173	24,203								
C600M-108		108	4.252	24,660								
C600M-110		110	4.331	25,116								
C600M-120	120	120	4.724	42,083	9.055	5.984	5.433	0.276	5.276	12	M16 x 110	184
C600M-130		130	5.118	45,590								
C600M-140	140	140	5.512	65,462	11.42	6.850	6.299	0.276	6.299	16	M16 x 120	184
C600M-150		150	5.906	70,138								

All dimensions are shown in inches unless stated otherwise. All dimensions and capacities are subject to change without notice.

CLIMAX

METAL PRODUCTS COMPANY
ISO 9001:2008

8141 Tyler Blvd., Mentor, Ohio 44060

Phone: 1-800-542-6552 • (440) 585-0300

Fax: 1-800-860-5553 • (440) 585-5762

Web: www.climaxmetal.com

Email: sales@climaxmetal.com



Distributed By:

Catalog No. 2011
2.5M0311AP