



1911 1920 1931 1934 1946 1952 1964 1968 1980 2002 2007



HELPING NORTH

SINCE 1911

AMERICA TOW

CEQUENT PERFORMANCE PRODUCTS, INC.

47912 Halyard Drive • Suite 100 • Plymouth, MI 48170 • www.cequentgroup.com

CUSTOMER SERVICE: PHONE 800-632-3290 • FAX 800-249-3827

EMAIL: customerservice@cequentgroup.com • technicalservice@cequentgroup.com

DISTRIBUTION CENTERS

USA	USA	USA	USA	USA	CANADA
California	Florida	Indiana	Pennsylvania	Texas	Burlington
Distribution Center	Distribution Center	Distribution Center	Distribution Center	Distribution Center	Distribution Centre
3181 S. Willow Ave. #104 Fresno, CA 93725	105-2 L.M. Gaines Blvd. Starke, FL 32091-4535	84 Commercial Road Building 3 Huntington, IN 46750	3 Bishop Place Camp Hill, PA 17011	1205 Post & Paddock Suite 100 Grand Prairie, TX 75050	1549 Yorkton Court Unit #3 Burlington, ON L7P 5B7

© Cequent Performance Products, Inc. All products & specifications subject to change without notice. Printed in the USA P/N 98929-2012 REV A 11/11 for 2012



0 16118 11339 6

TOWING TRAILERING & VEHICLE ACCESSORIES

FULTON



Bargman

Wesbar

DrawTite

REESE

TEKONSHA

HIDDEN HITCH

RESE

PRO SERIES

TOW-READY

PRO SERIES

TOW-READY

PRODUCT

We Are TOWING

CATALOG

TOWING TRAILERING & VEHICLE ACCESSORIES



HELPING NORTH

SINCE 1911

AMERICA TOW

REESE

DrawTite



TEKONSHA

HIDDEN HITCH

RESE

FULTON

Bargman

Wesbar

PRO SERIES

TOW-READY



Draw-Tite® is the premier manufacturer of custom trailer hitches. Each hitch must pass rigorous testing to become TESTED TOUGH™. Draw-Tite® leads the industry with the most complete line of hitches, towing products and vehicle accessories.



Reese® Elite fifth wheels, Sidewinder, 5th Airborne and weight distribution systems are designed and built to haul up to the heaviest of loads. Known for "Pioneering Performance", Reese® offers a complete line of towing accessories.



Hidden Hitch® hitches and receivers have a low profile design to complement the rear contours and aero dynamic styling of today's vehicles.



Tekonsha® is the industry leader and innovator in electric trailer brake controls and breakaway systems. No matter what you are towing, Tekonsha can help you stop it.



Fulton® jacks, winches, and couplers combine innovative design, performance and style with quality and value, making them the most popular choice for recreational and marine applications.



Bargman® lighting products provide complete solutions for the recreational vehicle industry. As a leading supplier to the transportation industry since 1931, Bargman has established itself as a trusted partner to commercial truck and light-duty trailer manufacturers and their respective aftermarkets.



Bulldog® gooseneck hitches, gooseneck couplers, trailer couplers and wedge-latch elements feature a high-strength, heavy duty design that makes them the most Tough and Trusted. Bulldog® jacks are also Tough and Trusted and built with uncompromising strength and materials engineered to hold up under rigorous working conditions.



Tow Ready® products include T-One® connectors, ModuLite® power modules, electrical adapters and accessories, to help make your electrical connections easy. Tow Ready® also has receiver and coupler locks for securing your hitches and trailers, and pintle hooks and accessories.



Pro Series™ offers the best values in one of the widest product lines in the towing market including fifth wheel hitches, gooseneck hitches, weight distribution system, receiver hitches, jacks, couplers, winches, brake controls, breakaway system and cargo management items. Pro Series products are made by the best names in the business and balance performance and features with price.



Wesbar® Incandescent and LED vehicle and trailer lighting products provide an extensive variety of lighting and reflector options for agricultural, industrial, marine, recreational, and utility trailers and vehicles. The expanded offering of waterproof, sealed and submersible lighting products is a result of Wesbar's continued commitment to the Marine Trailer Market.



ROLA® is the source for all things cargo management. Rola helps you transport gear on your roof, hitch or inside your vehicle, and always in style. For the best bike carriers, cargo baskets & bags, roof racks, luggage carriers, organizers and accessories, ROLA has you covered.



WE URGE ALL OTHER HITCH MANUFACTURERS TO ADOPT



TEST STANDARDS AS DEMANDING AS OURS

Our hitches have been Tested Tough more than twice as long as most other hitch brands have been around.

We've been testing beyond industry standards for more than 45 years. That's important, because you can be sure even Draw-Tite hitches purchased long ago were Tested Tough by a constantly updated, state-of-the-art lab – and have been tested by generations of field experience ever since.

We test every component of every hitch, every which way, and we always have.

TESTED TOUGH MEANS YOU GET A HITCH WITH:



Maximum Flexibility—Deflection testing 20% beyond industry standard requirements means more resilience, greater shock absorption.



Optimum Strength—Fatigue testing well beyond industry specs ensures fracture-free, long-term performance.

Tested Tough means that you get a hitching system that holds its own no matter what the world can dish out.



AMERICA'S FAVORITE HITCH

WWW.DRAW-TITE.COM

TABLE OF CONTENTS

NEW! Products 4-5

RECEIVER HITCHES..... A-1
 Receiver Hitches A-3 / A-13
 Ultra Frame® Class V Receiver Hitches A-4 / A-6
 Titan® Class V Receiver Hitches A-11
 Super Titan® Receiver Hitches A-12
 Motorhome Hitches A-14
 Front Mounted Receivers and Accessories A-15
 Hitch Accessories A-16

HITCH ACCESSORIES..... B-1
 Hitch Balls B-3 / B-4
 Ball Mounts B-5 / B-12
 Hitch Accessories B-13
 Pintle Hooks and Accessories B-14 / B-16
 Pins / Clips / Locks / Tube Covers B-17 / B-22

ELECTRICAL WIRING & ACCESSORIES..... C-1
 T-One® Connectors C-3 / C-21
 ModuLite® Power Modules / Converters C-22 / C-28
 2/4/5-Way Flat Connectors and Accessories C-29 / C-34
 6/7-Way Connectors and Wiring C-35 / C-46
 Vehicle / Trailer Adapters/Jumpers C-47 / C-50
 Electrical Accessories C-51 / C-57
 Technical - AG Lighting / Wiring Diagrams C-58 / C-62

WEIGHT DISTRIBUTION SYSTEMS..... D-1
 Weight Distribution Systems D-3 / D-14
 Sway Controls D-15 / D-16
 Weight Distribution Accessories D-17 / D-18

FIFTH WHEEL HITCHES..... E-1
 Fifth Wheel Hitches E-3 / E-13
 Fifth Wheel Hitch Accessories E-14 / E-16
 Fifth Wheel Hitch Application Guide E-17 / E-28

PIN BOXES..... F-1
 Gooseneck Coupler for RV's F-3 / F-4
 Pin Box Conversion F-5 / F-6
 Pin Boxes F-7 / F-11

GOOSENECK HITCH SYSTEMS..... G-1
 Gooseneck Coupler for RV's G-3 / G-4
 Gooseneck Hitch Systems G-5 / G-10
 Gooseneck Hitch System Accessories G-11
 Gooseneck Hitch Application Guide G-12 / G-18

BRAKE CONTROLS..... H-1
 Proportional / Timed Brake Controls H-3 / H-9
 Brake Control Accessories / Wiring H-10 / H-11
 Brake Control Wiring Harnesses / Application Guide H-12 / H-15

CARGO MANAGEMENT..... I-1
 Roof Racks and Accessories I-3 / I-6
 Bike Carriers and Accessories I-7 / I-14

CARGO MANAGEMENT (CONTINUED)
 Cargo Boxes and Accessories I-15 / I-18
 Cargo Carriers and Accessories I-19 / I-26
 Cargo Bags I-27 / I-28
 Automotive Covers, Protection, Organizers, Nets, Cargo Bars I-29 / I-32
 Securing and Accessories / Ramps I-33 / I-38
 Roof Rack Application Guide I-39 / I-45

JACKS / COUPLERS / WINCHES..... J-1
 Jacks J-3 / J-36
 Couplers J-37 / J-51
 Winches J-52 / J-62

VEHICLE ILLUMINATION..... K-1
 Tail Lights K-3 / K-24
 Auxiliary Lighting K-25 / K-26
 AG Lighting and Accessories K-27 / K-30
 Clearance / Side Marker Lights K-31 / K-47
 ID Light Bars K-48 / K-52
 License Plate Lights/Brackets / Reflectors K-53 / K-55
 Porch / Utility Lights / Assist Bars K-56 / K-58
 Interior Lights K-59 / K-60
 Planograms K-61 / K-65
 Technical - Federal Lighting Requirements / AG Lighting / Bulbs K-66 / K-75

LOCKS..... L-1
 Hitch / Trailer / Couplers Locks L-2 / L-4
 Cable / Accessory Locks L-5 / L-6

TRAILER ACCESSORIES..... M-1
 Breakaway Systems and Accessories M-3 / M-6
 Trailer Brake Replacement Parts M-7 / M-19
 Wheel Protection M-20 / M-22
 Trailer Accessories M-23 / M-33

VEHICLE ACCESSORIES..... N-1
 HindSight™ Camera System N-2
 Ramps / Anchoring Systems / Tow Bars / Towing Mirrors N-3 / N-4
 Transmission Coolers and Accessories N-5 / N-6
 Battery Post Adapter / Isolators N-7

TOOLS / TESTERS..... O-1
 Wiring / Brake Control / Circuit Testers O-2
 Hitch Installation Tools O-3

MERCHANDISING..... P-1
 Product Displays P-2 / P-7
 Header Signs/Cards / Gondola Wallpaper P-7 / P-8
 Merchandising Materials P-9 / P-12
 Suggested Planogram Layouts P-13 / P-40

INDEMNIFICATION PROGRAM..... Q-1
WARRANTIES..... Q-2
NUMERICAL PRODUCT LISTING..... Q-3

RECEIVER HITCHES

HITCH ACCESSORIES

ELECTRICAL WIRING & ACCESSORIES

WEIGHT DISTRIBUTION SYSTEMS

FIFTH WHEEL HITCHES

PIN BOXES

GOOSENECK HITCH SYSTEMS

BRAKE CONTROLS

CARGO MANAGEMENT

JACKS / COUPLERS / WINCHES

VEHICLE ILLUMINATION

LOCKS

TRAILER ACCESSORIES

VEHICLE ACCESSORIES

TOOLS / TESTERS

MERCHANDISING

NUMERICAL PRODUCT LISTING

All logos / names / trademarks are copyrights of their respective companies. Reproduction of this catalog (or any part thereof) without the permission of Cequent Performance Products Inc. is prohibited by law.



NEW PRO

TOWING



41943 - Draw-Tite®
Ultra Frame® with Cast Center Section
Page A-4



45325 - Reese®
Titan® Tri-Ball Mount
Page A-11



40567-002 - Draw-Tite®
Towing Starter Kit with Chrome Ball Mount
Page B-10

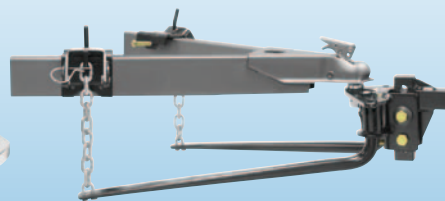

49581 - Pro Series™
RB3 Weight Distribution System
Page D-14



30866 - Reese®
R16 Fifth Wheel Hitch
Page E-5



30156 - Reese®
Fifth Wheel Rail Kit Mounting Adapter
Page E-4



94622 - Reese®
Goose Box™
Page G-3

JACKS | COUPLERS | WINCHES



500187 & 500188 - BULLDOG®
3.5K A-Frame Jack with Powered Drive
Page J-3

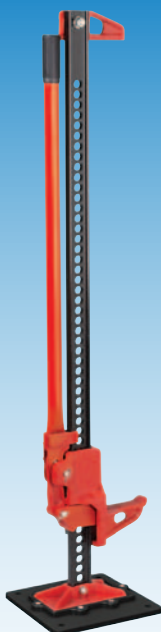

148700 - BULLDOG®
Multi-Jack
Page J-36



1289000300 - BULLDOG®
BX1 Gooseneck Coupler
Page J-43

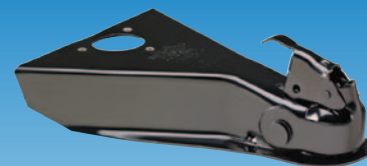

E338050303 - Pro Series™
Yoke Coupler
Page J-40



FW16000101 - Fulton®
F2® 1600 lb. Single Speed Winch
Page J-53

PRODUCTS

CARGO MANAGEMENT



59711 - ROLA®
Roof Rack - Universal
Crossbar RBU Series
Page I-4



59404 - ROLA®
Stingray™ Rooftop Bike Carrier
Page I-8



63144 - Pro Series™
Translite™ Bike Carrier
Page I-12



59003 - ROLA®
Airfoil SK™ Rooftop Cargo Boxes
Page I-16



63150 - Pro Series™
Bullet Box™ Rooftop Cargo Box
Page I-16



59550 & 59904 - ROLA®
Stingray™ Cargo Carrier &
Stingray™ Bike Rack Clip
Page I-10 & I-20

New



HITCH/ACCESSORY RATING GUIDE – Scan this barcode with your mobile phone to access: www.cequentgroup.com/accessrating.asp

ELECTRICAL | LIGHTING | ACCESSORIES

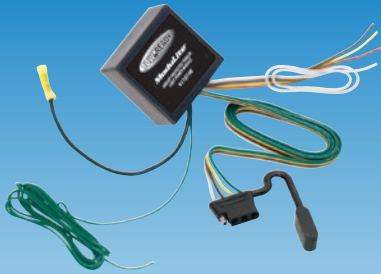

119146 - Tow Ready®
Modulite® Power Module
Page C-24



54006-009 - Bargman® / 20140 - Tow Ready®
Connectors - 7-Way Cold Weather & Fifth Wheel Gooseneck
Page C-38 & C-39



67302 - Tow Ready®
HindSight™ Back-Up Camera
Page N-2



54209-017 & 54209-018 - Wesbar®
LED Work Light with Magnetic Base
Page K-25



54209-008 - Wesbar®
LED Heavy-Duty AG Lights
Page K-27



63219KA, 63253 & 63254 - Tow Ready®
Locks - Keyed Alike, Hitch & Fifth Wheel Rail
Page L-3 & L-4

DRAW-TITE® CUSTOM BUILT TRAILER HITCHES

DRAW-TITE GIVES YOU TOP QUALITY IN EVERY HITCH AND RECEIVER WE MAKE:

- Solid all-welded construction for maximum strength and safety.
- Custom built according to manufacturer vehicle weight specifications and model year to ensure perfect fit and top towing performance.
- All Draw-Tite hitches meet and exceed V-5 and SAE J684 standards and are inspected for quality and workmanship.
- Computer-aided design and fatigue stress testing ensure a strong design that will withstand road abuse within specified capacities.
- Finish is black powder coat over e-coat (industry leading corrosion resistance).
- Backed by a nationwide limited lifetime warranty.

SELECTING THE RIGHT HITCH

- Determine the Gross Trailer Weight and Gross Tongue Weight of the trailer that you would like to tow. Check with the trailer manufacturer or if you are not sure, have it towed to a government inspection scale. Remember that the G.T.W. should reflect a fully loaded trailer.
- Consult your vehicle’s owner’s manual to determine if your vehicle is rated to safely tow your trailer.
- Use the chart to figure out the minimum “Class” of hitch that is required.
- Consult a Draw-Tite dealer to find out which hitches are available for your vehicle. Or visit our website: www.draw-tite.com.

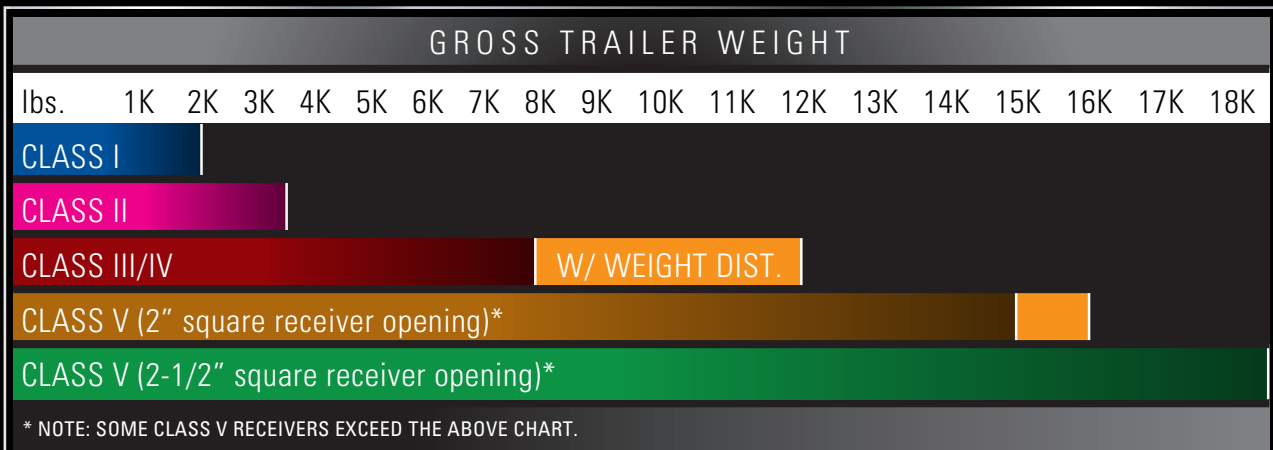

RECEIVER HITCHES

RECEIVER HITCHES

- Draw-Tite® Receiver Hitches - Class I / II
- Draw-Tite® Receiver Hitches - Class III / IV
- Draw-Tite® Receiver Hitches - Class V Ultra Frame®
- Draw-Tite® Receiver Hitches - Class V Ultra Frame® with Cast Center Section
- Hidden Hitch® Receiver Hitches - Class I / II
- Hidden Hitch® Receiver Hitches - Class III / IV
- Reese® Receiver Hitches - Class III / IV
- Reese® Receiver Hitches - Class V Titan®
- Reese® Receiver Hitches - Super Titan®
- Pro Series™ Receiver Hitches - Class I / II
- Pro Series™ Receiver Hitches - Class III / IV

ULTRA FRAME® CLASS V RECEIVER HITCHES

- Ultra Frame® Class V Receiver Hitches
- Ultra Frame® Class V Receiver Hitches with Cast Center Section
- Ultra Frame® Ball Mounts
- Ultra Frame® Hitch Balls
- Ultra Frame® Trunnion Style Weight Distribution
- Ultra Frame® Work Truck Hitch

TITAN® CLASS V RECEIVER HITCHES

- Titan® Class V Receiver Hitches
- Titan® Ball Mounts
- Titan® Hitch Balls
- Titan® Receiver Extensions / Reducer Sleeve
- Titan® Trunnion Style Weight Distribution

SUPER TITAN® RECEIVER HITCHES

- Super Titan® Receiver Hitches
- Super Titan® Ball Mounts with Hitch Balls
- Super Titan® Accessories
- Super Titan® Pintle Hook Mount

MOTORHOME HITCHES

- Multi-Fit Motorhome Hitches
- Universal Motorhome Hitches
- Motorhome Class III Receiver Hitches
- Step Bumper Hitches
- Class III Roll Pan Receiver Hitches

FRONT MOUNTED RECEIVERS / ACCESSORIES

- Front Mounted Receivers
- Front Mounted Receiver Accessories

HITCH ACCESSORIES

- Combo Bars
- Fasteners
- Safety Chain Loops





DRAW-TITE GIVES YOU TOP QUALITY IN EVERY HITCH AND RECEIVER WE MAKE:



- Solid all-welded construction for maximum strength and safety
- Custom built according to manufacturer & model year to ensure perfect fit and top towing performance
- Computer-aided design and fatigue stress testing ensure a strong design that will withstand road abuse within specified capacities
- All hitches meet or exceed V-5 and SAE J684 standards and are inspected for quality and workmanship
- Backed by a nationwide limited lifetime warranty
- Black powder coat finish over e-coat



CLASS I SPORTFRAME™ Part No. Series 24XXX

- 1-1/4" square receiver tube opening
- Economical Class I receiver style hitch
- Comes complete with removable drawbar, pin and clip
- Attaches to vehicle frame and/or bumper
- Black powder coat finish over e-coat

Description	Maximum Rated Capacity	
	Gross Trailer Wt.	Tongue Wt.
Weight Carrying	Up to 2,000 lbs.	Up to 200 lbs.



CLASS II FRAME HITCH™ Part No. Series 36XXX

- 1-1/4" square receiver tube opening
- Receiver style hitch with removable drawbar
- Comes complete with removable drawbar, pin and clip
- Neat appearance and all frame attachments
- Black powder coat finish over e-coat

Description	Maximum Rated Capacity	
	Gross Trailer Wt.	Tongue Wt.
Weight Carrying	Up to 3,500 lbs.	Up to 300 lbs.

**NOW YOU SEE IT,
NOW YOU DON'T!
ONCE INSTALLED THE
INVISIBLE HITCH IS
COMPLETELY HIDDEN
FROM VIEW!**



CLASS I/II INVISI-HITCH™ Part No. Series 285XX

- 1-1/4" square receiver tube opening
- One piece construction for a stronger hitch and easier installation
- Direct attachment allows hitch to be affixed well under vehicle for minimum visibility when drawbar is removed
- Includes mounting hardware and easy to read instructions
- Removable drawbar & accessory adapter sold separately
- Black powder coat finish over e-coat

Description	Maximum Rated Capacity	
	Gross Trailer Wt.	Tongue Wt.
Weight Carrying	Up to 3,500 lbs.	Up to 300 lbs.

28351
sold separately

28451
sold separately



New

HITCH / ACCESSORY - RATING GUIDE

Scan this barcode with your mobile phone to access:
www.cequentgroup.com/accessrating.asp



CLASS III/IV SQUARE & ROUND TUBE MAX-FRAME™ RECEIVERS Part No. Series 75XXX

- 2" square receiver tube opening
- Max-Frame receivers are designed for customers with trucks, vans and sport utility vehicles
- Designed for today's stylish sport utility vehicles, round tube receivers complement vehicle appearance
- All frame attachments
- Black powder coat finish over e-coat
- Ball mount, hitch ball, wiring and accessories sold separately
- J-Pin® ready
- 75XXX ball mounts #23 and #53 are available (Max-Frame Program)



Description	Maximum Rated Capacity	
	Gross Trailer Wt.	Tongue Wt.
Weight Carrying	Up to 8,000 lbs.	Up to 1,200 lbs.
Weight Distributing	Up to 12,000 lbs.	Up to 1,200 lbs.



CLASS III/IV MAX-E-LOADER™ RECEIVERS Part No. Series 41XXX

- 2" square receiver tube opening
- Max-E-Loader's long side bracket design distributes the towing load over a greater portion of the tow vehicle frame
- All frame attachments
- J-Pin® ready
- Black powder coat finish over e-coat

Description	Maximum Rated Capacity	
	Gross Trailer Wt.	Tongue Wt.
Weight Carrying	Up to 6,000 lbs.	Up to 600 lbs.
Weight Distributing	Up to 12,000 lbs.	Up to 1,200 lbs.



See page A-5 for accessories for the Ultra Frame Receivers

CLASS V ULTRA FRAME® RECEIVERS Part No. Series 419XX

- 2" square receiver tube opening
- Designed for full-size long wheelbase trucks, vans and utility vehicles with full frames and heavy-duty suspensions
- Ideal for high tongue weight applications (Example: Toy Hauler)
- Strong, secure heavy-duty side bracket design
- All frame attachments
- J-Pin® ready
- Black powder coat finish over e-coat
- **NEW!** Redesign of Ultra Frame® receivers to include Cast Center Section
 - New rugged appearance
 - Cast steel material
 - Bigger chain loops
 - Tighter ball mount fit
 - Reinforced pin hole



ULTRA FRAME® RECEIVERS With Cast Center Section



Description	Maximum Rated Capacity	
	Gross Trailer Wt.	Tongue Wt.
CLASS V ULTRA FRAME® RECEIVERS		
Weight Carrying	Up to 15,000 lbs.	Up to 1,500 lbs.
Weight Distributing	Up to 16,000 lbs.	Up to 1,600 lbs.
CLASS V ULTRA FRAME® RECEIVERS WITH CAST CENTER SECTION		
Weight Carrying	Up to 16,000 lbs.	Up to 2,400 lbs.
Weight Distributing	Up to 16,000 lbs.	Up to 1,600 lbs.

NOTE: Contact Customer Service for availability of new Cast Center Section part numbers



ULTRA FRAME® SOLID SHANK BALL MOUNTS



Part No.	Rating (lbs.) GTW/TW	Ball Hole Size	A Length	B Rise	C Drop	Style
4280	12,000/1,200	1-1/4"	8-1/2"	1"	2"	1
4284	12,000/1,200	1-1/4"	12"	1"	2"	1
4281	12,000/1,200	1-1/4"	8-1/2"	3"	4"	3
4285	12,000/1,200	1-1/4"	12"	3"	4"	3
4282	12,000/1,200	1-1/4"	9-1/2"	5"	6"	3
4283	12,000/1,200	1-1/4"	9-1/2"	7"	8"	3



All hitch balls designed with wrench flats

ULTRA FRAME® HITCH BALLS

Ball Dia. A	Finish		Shank Dia. B	Shank Length C	Drawbar Thickness Range	GTW GVWR Rating
	Zinc	Chrome				
2-5/16"	63835	63834	1-1/4"	2-3/4"	3/8"-1"	12,000
2-5/16"	-	63836	1-1/4"	2-3/4"	3/8"-1"	14,000
2-5/16"	-	63840	1-1/4"	2-3/4"	3/8"-1"	20,000

ULTRA FRAME® WEIGHT DISTRIBUTING TRUNNION STYLE

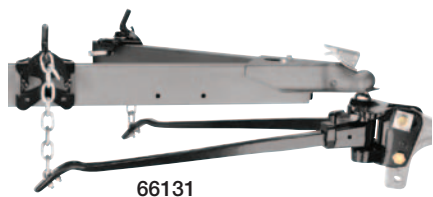

- Raised hitch ball platform eliminates the need for raised hitch balls
- Easy-to-use serrated washer
- Forged ball platform and spring bar mounts
- Rated up to 15,000 lbs. GTW / 1,500 lbs. TW

Part No.	Description	Gross Trailer Wt.	Tongue Wt.
66131	Weight Distributing Hitch	15,000 lbs.	1,500

Use Shank #63970 or #63971

See page A-4 for
Ultra Frame™ Receivers

ULTRA FRAME® WORK TRUCK HITCH

**MANUFACTURED FOR SERVICE BODY
& FLAT BED STAKE TRUCKS**



#41991 - 62" Center Section

MIX & MATCH CENTER SECTION AND SIDE BRACKETS

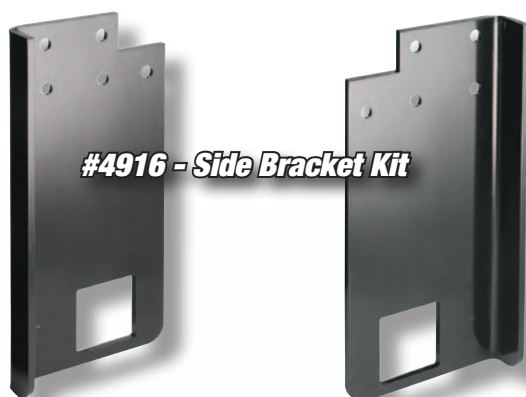

#4916 - Side Bracket Kit

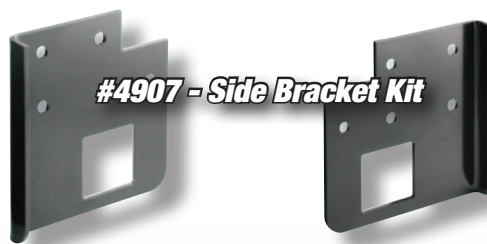

#4907 - Side Bracket Kit



**#58374 - End Caps
are also available**



#41990 - 44" Center Section

- **VERSATILE FOR VARIOUS MAKES AND MODELS**
- **FABRICATION KIT REQUIRES WELDING**
- **41991 SATISFIES DOT SEC. 393 .86 (B) (1)**

ULTRA FRAME® SERVICE BODY RECEIVERS

Part No.	Description	GTW	TW
41991-07	Includes 41991 (62") & 4907	16,000 lbs.	1,600 lbs.
41991-16	Includes 41991 (62") & 4916	16,000 lbs.	1,600 lbs.
41990-07	Includes 41990 (44") & 4907	16,000 lbs.	1,600 lbs.
41990-16	Includes 41990 (44") & 4916	16,000 lbs.	1,600 lbs.



HIDDEN HITCH - FEATURES AND BENEFITS



- Low profile design to compliment the rear contours and aerodynamic styling of today's vehicles
- Removable drawbars and ball mounts enhance the appearance of the vehicle when not in use
- Custom designed hitches are specific to vehicle type and model year for simple installation and superior fit
- Custom designed hitches reduce cutting of bumper and drilling
- All hitches meet or exceed V-5 and SAE J684 standards and are inspected for quality and workmanship
- Backed by a nationwide limited lifetime warranty
- Black powder coat finish over e-coat



CLASS I Part No. Series 6XXXX

- Sleek design built to enhance the rear contour of the vehicle in 1-1/4" square drawbar
- Comes complete with removable drawbar, pin and clip
- Hitch ball, wiring and accessories sold separately
- Contoured round tube design where appropriate

Description	Maximum Rated Capacity	
	Gross Trailer Wt.	Tongue Wt.
Weight Carrying	Up to 2,000 lbs.	Up to 200 lbs.



CLASS II Part No. Series 9XXXX

- 1-1/4" square receiver tube opening
- One piece construction for a stronger hitch and easier installation
- Direct attachment allows hitch to be affixed well under vehicle for minimum visibility when drawbar is removed
- Comes complete with removable drawbar, pin and clip
- Hitch ball, wiring and accessories sold separately

Description	Maximum Rated Capacity	
	Gross Trailer Wt.	Tongue Wt.
Weight Carrying	Up to 3,500 lbs.	Up to 300 lbs.

**NOW YOU SEE IT,
NOW YOU DON'T!
ONCE INSTALLED THE
INVISIBLE HITCH IS
COMPLETELY HIDDEN
FROM VIEW!**



CLASS I/II INVISI-HITCH™ Part No. Series 285XX

- 1-1/4" square receiver tube opening
- One piece construction for a stronger hitch and easier installation
- Direct attachment allows hitch to be affixed well under vehicle for minimum visibility when drawbar is removed
- Includes mounting hardware and easy to read instructions
- Drawbar, accessory adapter, hitch ball, wiring and accessories sold separately

Description	Maximum Rated Capacity	
	Gross Trailer Wt.	Tongue Wt.
Weight Carrying	Up to 3,500 lbs.	Up to 300 lbs.



28351
sold separately

28451
sold separately



CLASS III/IV SERIES Part No. Series 7XXXX, 825XX, 87XXX

- 2" square receiver tube opening
- Includes mounting hardware and easy to read instructions
- Ball mount sold separately on 825XX
- Ball mount, hitch ball, wiring and accessories sold separately
- J-Pin® ready (Only on new hitch designs)
- 7XXXX & 87XXX ball mounts #127 and #139 are available (Receiver Plus Program)

Description	Maximum Rated Capacity	
	Gross Trailer Wt.	Tongue Wt.
Weight Carrying	Up to 8,000 lbs.	Up to 1,200 lbs.
Weight Distributing	Up to 12,000 lbs.	Up to 1,200 lbs.

CLASS III/IV UNIVERSAL MULTI-FIT RECEIVER

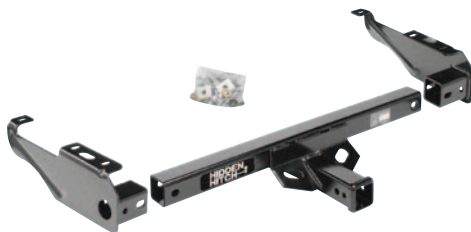

- SHIPPED IN RETAIL CARTON
- Up to 6,000 lbs. / 600 lbs. WC - 10,000 lbs. / 1,000 lbs. WD
- Designed to fit a wide range of pick-up trucks
- Includes hitch receiver cover, mounting hardware and easy to read instructions
- Ball mount, hitch ball, wiring and accessories sold separately

Part No.	Description
82000	Class III/IV Multi-Fit Receiver



New

HITCH / ACCESSORY - RATING GUIDE

Scan this barcode with your mobile phone to access:
www.cequentgroup.com/accessrating.asp

QUICK DEFINITIONS

GTW = Gross Trailer Weight ... Weight of the trailer fully loaded

TW = Tongue Weight ... Weight exerted by the trailer coupler on the hitch ball

WC = Weight Carrying ... Tow rating capacity of a hitch without a weight distributing system

WD = Weight Distributing ... Tow rating capacity of a hitch when using a weight distributing system



REESE GIVES YOU TOP QUALITY IN EVERY HITCH AND RECEIVER WE MAKE:



- Solid all-welded construction for maximum strength and safety
- Custom built according to manufacturer & model year to ensure perfect fit and top towing performance
- Computer-aided design and fatigue stress testing ensure a strong design that will withstand road abuse within specified capacities
- All hitches meet or exceed V-5 and SAE J684 standards and are inspected for quality and workmanship
- Backed by a nationwide limited lifetime warranty
- Black powder coat finish over e-coat

CLASS III/IV PROFESSIONAL RECEIVERS

Part No. Series 33XXX, 44XXX



- 2" square receiver tube opening
- Round tube designs available on some models
- Includes distinctive patented collar and plug
- Ball mount, pin & clip sold separately
- Many applications are "no drill" for fast and easy installation
- Black powder coat finish over e-coat



Description	Gross Trailer Wt.	Maximum Rated Capacity	
		Tongue Wt.	
Weight Carrying	Up to 8,000 lbs.	Up to 1,200 lbs.	
Weight Distributing	Up to 12,000 lbs.	Up to 1,200 lbs.	

CLASS III/IV PREMIUM RECEIVERS

Part No. Series 35XXX, 36XXX, 37XXX



- 2" square receiver tube opening
- Round tube designs available on some models
- Boxed for easy shipping
- Includes distinctive patented collar and plug
- Ball mount, pin & clip sold separately
- Designed for a great custom fit
- Many applications are "no drill" for fast and easy installation
- Black powder coat finish over e-coat

Description	Gross Trailer Wt.	Maximum Rated Capacity	
		Tongue Wt.	
Weight Carrying	Up to 7,500 lbs.	Up to 750 lbs.	
Weight Distributing	Up to 12,000 lbs.	Up to 1,200 lbs.	

QUICK DEFINITIONS

GTW = Gross Trailer Weight ... Weight of the trailer fully loaded

TW = Tongue Weight ... Weight exerted by the trailer coupler on the hitch ball

WC = Weight Carrying ... Tow rating capacity of a hitch without a weight distributing system

WD = Weight Distributing ... Tow rating capacity of a hitch when using a weight distributing system



CLASS III/IV MULTI-FIT RECEIVERS

Part No. 37034, 37051, 37069, 37152

- 2" square receiver tube opening
- 4 hitch models fit full-size pick-up trucks, SUVs and full-size vans, and light pick-up trucks
- 37034 & 37051 features a contemporary round tube design
- Boxed for easy shipping
- Includes distinctive patented collar and plug
- Ball mount, pin & clip sold separately
- Black powder coat finish over e-coat
- Limited 3 year warranty

Description	Maximum Rated Capacity	
	Gross Trailer Wt.	Tongue Wt.
Weight Carrying	Up to 7,000 lbs.	Up to 700 lbs.
Weight Distributing	Up to 12,000 lbs.	Up to 1,200 lbs.



CLASS V TITAN® RECEIVERS Part No. Series 45XXX

- 2-1/2" square receiver tube opening
- Designed for full-size long wheelbase trucks, vans and utility vehicles with full frames and heavy-duty suspensions
- Ideal for high tongue weight applications (Toy Hauler & Commercial)
- Strong, secure heavy-duty side bracket design
- All frame attachments
- Pin, clip and receiver tube cover included
- Welded electrical bracket included

See page A-11 for accessories for the Titan Receivers

Description	Maximum Rated Capacity	
	Gross Trailer Wt.	Tongue Wt.
Weight Carrying	Up to 18,000 lbs.	Up to 2,000 lbs.
Weight Distributing	Up to 18,000 lbs.	Up to 2,500 lbs.



New

HITCH / ACCESSORY - RATING GUIDE

Scan this barcode with your mobile phone to access:
www.cequentgroup.com/accessrating.asp



CLASS V TITAN® RECEIVERS Part No. Series 45XXX

- Large 2-1/2" square receiver opening allows for larger capabilities
- Designed for heavy duty use with 3/4 & 1-ton vehicles only
- Fits most full-size pickups and SUVs
- Designed to fit with standard factory step bumper
- Ideal for high tongue weight applications (Toy Hauler & Commercial)



45322

45122



45325



All hitch balls built with wrench flats

Description	Maximum Rated Capacity	
	Gross Trailer Wt.	Tongue Wt.
Weight Carrying	Up to 18,000 lbs.	Up to 2,000 lbs.
Weight Distributing	Up to 18,000 lbs.	Up to 2,500 lbs.

TITAN® BALL MOUNTS

- 2-1/2" square shank for use exclusively with Titan® receivers

Part No.	Rating (lbs.) GTW/TW	Ball Hole Size	A Length	B Rise	C Drop	Style
45122	14,000/1,400	1-1/4"	9-1/2"	1-1/2"	3"	3
45123	13,000/1,300	1-1/4"	10"	3-1/2"	5"	3
45291	13,000/1,300	1-1/4"	10-1/2"	-	7-3/4"	3
45322	18,000/2,000	1-1/4"	10"	1-1/2"	3"	3
45323	18,000/2,000	1-1/4"	10"	3-1/2"	5"	3

Part No.	Description	Rating (lbs.) GTW/TW	Shank Length	Ball Size
45325	Titan® Tri-Ball Mount, Hollow Shank, Black Balls	2,000/200 10,000/1,000 14,000/1,400	8-3/4" 8-3/4" 7-1/2"	1-7/8" 2" 2-5/16"

TITAN® HITCH BALLS

Ball Dia. A	Finish		Shank Dia. B	Shank Length C	Drawbar Thickness Range	GTW GVWR Rating
	Zinc	Chrome				
2-5/16"	-	63836	1-1/4"	2-3/4"	3/8"-1"	14,000
2-5/16"	-	63840	1-1/4"	2-3/4"	3/8"-1"	20,000

TITAN® RECEIVER EXTENSIONS

- Ideal for slide-out campers with extended overhangs
- 2" opening for use w/standard ball mounts & hitch-mounted accessories
- For use with Titan® receivers only
- Integrated electrical bracket attached



45292

Part No.	Description	Length	WC(lbs.)	WD(lbs.)
45292	Receiver Extension	24"	6,000	8,000
		34"	4,500	6,000
45018	Receiver Extension	41"	5,000	7,500
		48"	4,000	6,000



58102

TITAN® REDUCER SLEEVE

- Reduces 2-1/2" Titan® receiver to 2" opening for hitch-mounted accessories

Part No.	Description
58102	Titan® Reducer Sleeve from 2-1/2" to 2"

TITAN® WEIGHT DISTRIBUTING TRUNNION STYLE

- Trunnion style WD kit with integrated cams for use with Dual Cam Sway Control
- Perfect for use with horse trailers and RV's with **heavy tongue** weights, great for agricultural, marine and recreational use
- Adjustable hitch bar sold separately

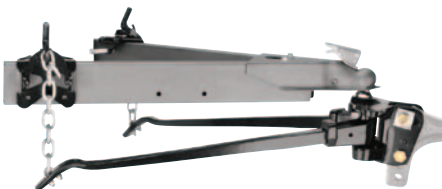

Part No.	Description	Gross Trailer Wt.	Tongue Wt.
66006	Weight Distributing Hitch	17,000 lbs.	1,700

Use Shank #54976 or #54977

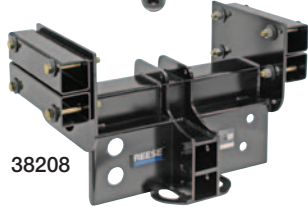

38208



38211



38023

SUPER TITAN BALL MOUNT (INCLUDED)



38180



38735



58388



38186

SUPER TITAN® 4000 - 25K

- Large 3" square receiver opening
- Rated for 25,000 lbs. weight carry capacity; 4,000 lbs. tongue weight
- Dual stacked receiver tubes for proper height adjustments
- Two electrical plug and air brake hook up mounting locations for easy trailer attachments
- For frame widths from 34" to 34-1/2"
- Air brake fittings for easy trailer hookups
- 2-5/16" ball and ball mount included
- Pin & clip included

Note: 38124 is 14-1/2" from bottom of frame to bottom of dual stacked receiver tube Note: 38208 is 10-1/2" from bottom of frame to bottom of dual stacked receiver tube

Part No.	Description
38124	Super Titan® 4000 25K Weld-On Receiver w/3" Sq. Ball Mount & 2-5/16" Ball, Includes 3/4" Pin & Clip
38208	Super Titan® 4000 25K Bolt-On Receiver w/3" Sq. Dual Ball Mount, 2" & 2-5/16" Balls, Includes 3/4" Pin & Clip

SUPER TITAN® 3000 - 20K

- Large 3" square receiver opening
- 20,000 lbs. weight carry capacity; 3,000 lbs. tongue weight
- Adjustable cross tube for proper height
- Two electrical plug and air brake hook up mounting locations for easy trailer attachments
- Air brake hook up locations
- 2-5/16" ball and ball mount included
- Pin & clip included
- For frame widths from 33-1/2" to 34-1/2"
- Welds to frame of vehicle

Note: 38023 is 10" from bottom of frame to bottom of receiver tube Note: 38211 is 14-1/2" from bottom of frame to bottom of receiver tube

Part No.	Description
38023	Super Titan® 3000 20K Weld-On Receiver w/3" Sq. Ball Mount & 2-5/16" Ball, Includes 3/4" Pin & Clip
38211	Super Titan® 3000 20K Weld-On Receiver w/3" Sq. Ball Mount & 2-5/16" Ball, Includes 3/4" Pin & Clip

SUPER TITAN® DUAL BALL MOUNT

- For 3" square receivers • 9" Length
- Includes 2" (17,000 lbs.) & 2-5/16" (25,000 lbs.) hitch balls

Part No.	Description
38180	Super Titan® Dual Ball Mount

SUPER TITAN® ACCESSORIES

Part No.	Description
58388	Super Titan® 3/4" Hitch Pin and Clip for 3" Square
38735	Super Titan® Reducer Sleeve from 3" to 2"

SUPER TITAN® PINTLE HOOK MOUNT

- Designed for 3" receivers
- Converts 3" receivers for use with pintle-type trailers, quickly and easily
- Provides mounting for both ball and combo pintle hooks
- Pin and clip must be ordered separately (3/4" hitch pin diameter required)

Part No.	Description
38186	Super Titan® Pintle Hook Mount, 25,000 lbs. capacity



PRO SERIES™ RECEIVER HITCHES

- Solid all-welded construction for maximum strength and safety
- Custom built according to manufacturer & model year to ensure perfect fit and top towing performance
- Computer-aided design and fatigue stress testing ensure a strong design that will withstand road abuse within specified capacities
- All hitches meet or exceed V-5 and SAE J684 standards and are inspected for quality and workmanship
- Backed by a nationwide 3-year limited warranty
- Black powder coat finish over e-coat

CLASS I RECEIVERS Part No. Series 51XXX



- 1-1/4" square receiver tube opening
- Economical Class I receiver style hitch
- Comes complete with removable drawbar, pin and clip
- Attaches to vehicle frame and/or bumper
- Black powder coat finish over e-coat

Description	Maximum Rated Capacity	
	Gross Trailer Wt.	Tongue Wt.
Weight Carrying	Up to 2,000 lbs.	Up to 200 lbs.

CLASS II RECEIVERS Part No. Series 51XXX



- 1-1/4" square receiver tube opening
- Receiver style hitch with removable drawbar
- Comes complete with removable drawbar, pin and clip
- Neat appearance and all frame attachments
- Black powder coat finish over e-coat

Description	Maximum Rated Capacity	
	Gross Trailer Wt.	Tongue Wt.
Weight Carrying	Up to 3,500 lbs.	Up to 300 lbs.

CLASS III/IV SQUARE & ROUND TUBE RECEIVERS

Part No. Series 51XXX



- 2" square receiver tube opening
- Pro Series™ receivers are designed for customers with trucks, vans and sport utility vehicles
- Designed for today's stylish sport utility vehicles, round tube receivers complement vehicle appearance
- All frame attachments
- J-Pin® ready
- Black powder coat finish over e-coat

Description	Maximum Rated Capacity	
	Gross Trailer Wt.	Tongue Wt.
Weight Carrying	Up to 6,000 lbs.	Up to 600 lbs.
Weight Distributing	Up to 10,500 lbs.	Up to 1,050 lbs.

QUICK DEFINITIONS

GTW = Gross Trailer Weight ... Weight of the trailer fully loaded

TW = Tongue Weight ... Weight exerted by the trailer coupler on the hitch ball

WC = Weight Carrying ... Tow rating capacity of a hitch without a weight distributing system

WD = Weight Distributing ... Tow rating capacity of a hitch when using a weight distributing system

MULTI-FIT MOTORHOME HITCH



5350

- 2" receiver tube accepts all standard utility ball mounts, providing ball height adjustment for level towing
- Simple three-piece construction makes assembly and installation fast and easy
- Attachment hardware included
- J-Pin® ready
- Black powder coat finish over e-coat



Part No.	Description
5350	Motorhome Hitch, Adjusts 24"-46" wide 6,000/750 lbs. WD – 5,000/500 lbs. WC

UNIVERSAL MOTORHOME HITCH



82200

- Frame brackets are adjustable



Part No.	Description
82200	Motorhome Hitch, Adjusts 31"-46" wide 6,000/750 lbs. WD – 5,000/500 lbs. WC
82201	Motorhome Hitch, Adjusts 47"-71" wide 3,500/300 lbs. WC

MOTORHOME CLASS III RECEIVER



36010

- Features adjustable brackets to fit different frame widths
- Ideal for Class A & Class C motorhomes
- 2" hitch box opening



Part No.	Description
36010	5,000 WC, universal up to 46" wide

STEP BUMPER HITCHES



81378

- Do not exceed maximum GTW of bumper or hitch
- Not to be used with weight distributing systems
- May require modification or additional spacers for installation on late model pick-ups



Part No.	Description
81378	Class II Step Bumper and Receiver Hitch not for use with weight distributing equipment

CLASS III ROLL PAN RECEIVERS Part No. Series 8257X



82574

- Up to 5,000 lbs. / 500 lbs. WC - 7,500 lbs. / 750 lbs. WD
- Designed to fit late model pick-up trucks with factory close-out panels or after-market roll pans
- May require cutting of the roll pan
- May require use of a flip-down license plate bracket - not included
- Includes mounting hardware and easy to read instructions



Part No.	Year	Application	Roll Pan Style	O.E.M. or Aftermarket	Through License Plate or Below	Spare tire May Be Retained Under Vehicle Except
82574	88-00	Chevy/GMC Full Size Pickup Old Body Style	1	Aftermarket	Through	P245/75R16, P265/75R16 on short box models only
82575	99-05	Chevy/GMC New Body Style	1	Aftermarket	Through	P245/75R16 on short box models only
82571	83-04	Chevy/GMC S-10, S-15, Sonoma	2	OEM	Through	All on short box only

ROLLPAN

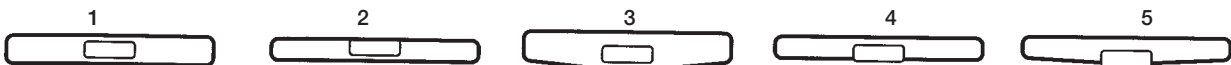



FRONT MOUNTED RECEIVERS

Part No. Series 65XXX

- Up to 9,000 lbs. Line Pull / 500 lbs.TW
- 2" square receiver tube opening
- Front mounted receivers offer a secure and useful attachment point
- All frame attachments
- J-Pin® ready
- Black powder coat finish over e-coat



6495



6980



6715



6758



5443



49802



6771

WINCH ADAPTER

Our front mounted receivers are rated for 9,000 lbs. line pull. This makes them ideal for use with winches. We offer a winch adapter that connects the winch to the receiver. They accept most models of Superwinch, Ramsey and Warn. Will not fit with S-4500 Superwinch.

Part No.	Description
6495	Winch Mounting Plate
6980	Handle Kit for #6495 Winch Mounting Plate

SPARE TIRE CARRIER

The spare tire carrier is ideal for relocating spare tires to the front of the vehicle using a front mounted receiver. It has a universal bolt pattern for mounting a variety of tire sizes.

Part No.	Description
6715	Spare Tire Carrier

WORK STEP

The work step is useful for gaining access to engine compartment, particularly with 4WD vehicles. Can also be used on rear Class III/IV receivers.

Part No.	Description
6758	Work Step

LICENSE PLATE ADAPTER

Some States and Provinces require a front license plate. The license plate adapter offers a simple solution where the front hitch interferes with the plate.

Part No.	Description
5443	License Plate Adapter

FOLD DOWN LICENSE PLATE HOLDER

Part No.	Description
49802	Fold Down License Plate Holder

RECEIVER TUBE SKID SHIELD

Off road enthusiasts know what this one is for. It is recommended for use with receivers that are mounted below the bumper.

Part No.	Description
6771	Receiver Tube Skid Shield

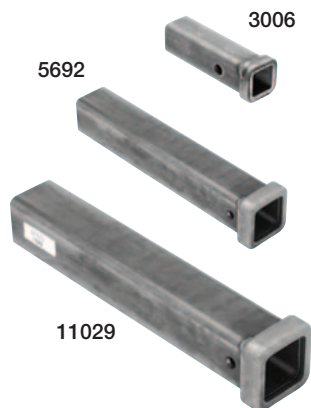

COMBO BARS - UNPAINTED

Designed for use in fabricating undercar receiver hitches when a receiver is not available.

- Made of cold formed structural tubing
- Sized and punched to fit all common weight distributing hitch ball mounts or utility ball mounts

Part No.	Length	Dia.	Ring
2850	6"	2" x 2"	Standard
11081	8"	2" x 2"	Standard
2851	12"	2" x 2"	Standard
2898	18"	2" x 2"	Standard
2852	24"	2" x 2"	Standard
2853	36"	2" x 2"	Standard
2854	48"	2" x 2"	Standard
3006	6"	1-1/4" x 1-1/4"	Standard
5691	12"	2" x 2"	Cast
5692	18"	2" x 2"	Cast
11029	18"	2-1/2" x 2-1/2"	Cast



COMBO BARS - PAINTED

Part No.	Length	Dia.	Ring
80806	6"	2" x 2"	Standard
80812	12"	2" x 2"	Standard
80818	18"	2" x 2"	Standard

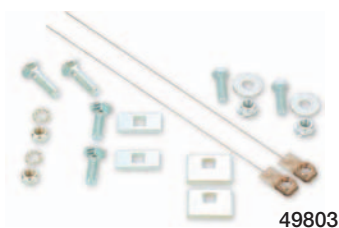

FASTENERS

- Bulk Packaged

Part No.	Description
1591	Fastener Assortment (Hex bolts, blocks, etc...)
49803	Fastener Assortment (Carriage bolts, blocks, etc...)

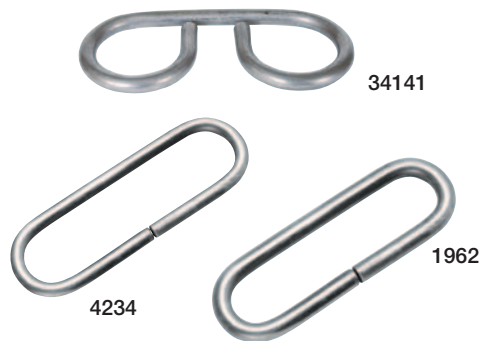

SAFETY CHAIN LOOPS

Part No.	Description
4234	2,000 lbs. Class I Safety Chain Loop
1962	5,000 lbs. Class II/III Safety Chain Loop
34141	10,000 lbs. Class IV Safety Chain Loop

SELECTING THE RIGHT BALL MOUNT & HITCH BALL

LENGTH

Distance from the center of the ball hole to the center of the pin hole

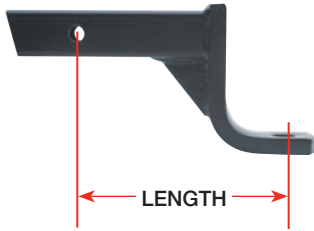

RISE

Distance from the top of the shank to the top of the ball platform

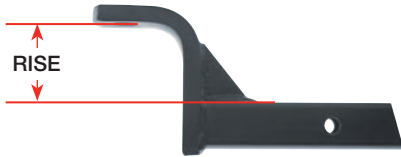

DROP

Distance from the top of the shank to the top of the ball platform



SELECTING THE RIGHT BALL MOUNT

Tow vehicle and trailer level



For safe, comfortable towing, the trailer should always be set up to tow on a level plane.

Trailer not level



Sometimes a trailer's tongue is higher or lower than the ball mount on the vehicle, and a ball mount with a "rise" or a "drop" is required to level the trailer.

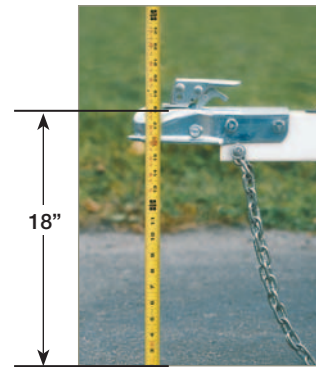
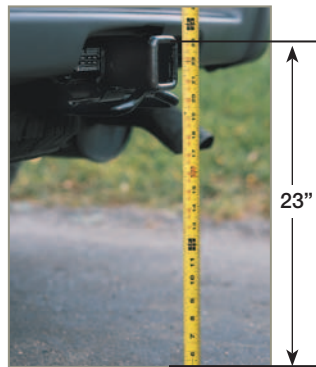

MEASURING FOR THE PROPER BALL MOUNT

1. Measure from the ground to the top of the hitch.
2. Measure from the ground to the (inside) top of the trailer coupler, when level.
3. Subtract the height of the hitch ball (most are 2-1/2" - 3" high) from coupler measurement.
4. An 8" drop is needed to make the trailer level.

THE DIFFERENCE IN THE TWO MEASUREMENTS IS THE AMOUNT OF BALL MOUNT "RISE" OR "DROP" REQUIRED.

SELECTING THE RIGHT HITCH BALL

Selecting the right hitch ball is a must for trouble-free towing.

Always use the properly rated hitch ball for your towing system.

- Your towing system's maximum weight rating is always equal to the lowest rated item in the system
- Your hitching system cannot be upgraded to a rating higher than the maximum rating of your hitch

For example, a 3,500 lbs. ball on a 2,000 lbs. max trailer weight-rated hitch does not increase your towing capacity to 3,500 lbs. Your hitching system is still rated at 2,000 lbs.

Conversely, a 2,000 lbs. ball on a 3,500 lbs. max trailer weight-rated hitch decreases your maximum towing capacity to 2,000 lbs.

The hitch ball diameter (A) must be the same diameter as the trailer coupler (1-7/8", 2", or 2-5/16").

The shank diameter (B) of the hitch ball should be the same as the hole diameter in the (correct) ball mount you selected.

The shank length (C) should be long enough to allow at least two threads to be visible when the hitch ball is installed and the nut completely tightened.

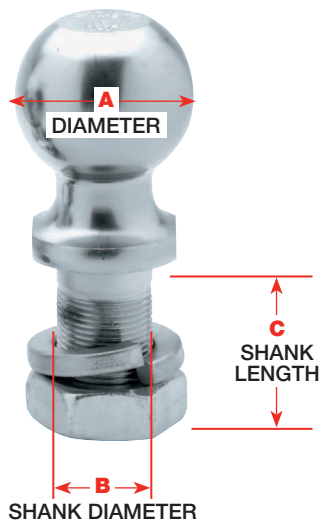

HITCH ACCESSORIES

HITCH BALLS

Interchangeable Hitch Ball System

Hitch Balls

BALL MOUNTS

Class I & II Drawbars

Ball Mounts

Solid Forged Ball Mounts

Aluminum Solid Forged Ball Mounts

Ultra Frame® Ball Mounts

Titan® Ball Mounts

Cushioned Ball Mounts

Towing Starter Kits

Adjustable Ball Mounts

Reversible Dual / Tri-Ball Mounts

Super Titan® Dual-Ball Mounts

Titan® Tri-Ball Mount

HITCH ACCESSORIES

Bumper Guard

Reducer Bushing

Receiver Adapters

Reducer Sleeves

Receiver Extensions

PINTLE HOOKS AND ACCESSORIES

Pintle Hooks / Mounts

Pintle Accessories

PINS / CLIPS / LOCKS / TUBE COVERS

Pins and Clips

Hitch / Trailer / Couplers Locks

Tube Covers





Designed to accommodate towing multiple trailers with ease, Tow Ready Interchangeable Hitch Ball System allows you to change hitch ball sizes in seconds without any tools. Available in 2 and 3-ball sets, these kits feature a quick-release, positive-latch design. Available in 3/4" and 1" shank models.



INTERCHANGEABLE HITCH BALL SETS

- Innovative quick release changes balls in seconds
- Rated capacities up to 8,000 lbs.
- Durable heat treated shank
- New positive latch design
- No special tools required

Part No.	Shank	Ball A	Ball B	Ball C	Max GTW (lbs.)
63801	3/4"	1-7/8"	2"	—	5,000
63802	1"	1-7/8"	2"	—	8,000
63804	1"	—	2"	2-5/16"	8,000
63803	1"	1-7/8"	2"	2-5/16"	8,000



STEP 1: ATTACH SHANK

- Attach correct shank to drawbar or ball mount
- Torque to required tightness



STEP 2: ATTACH BALL

- Select the correct ball size for your trailer
- Place ball on shank



STEP 3: TIGHTEN LOCKING HEAD

- Innovative locking screw requires only 1/4 turn to secure
- No need for special tools

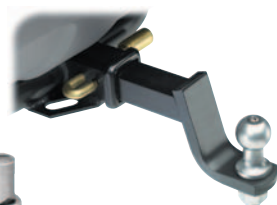

YOU'RE TOW READY!



REPLACEMENT PARTS

Part No.	Description	Max GTW (lbs.)
63805	1-7/8" Interchangeable Hitch Ball Head	—
63806	2" Interchangeable Hitch Ball Head	—
63807*	2-5/16" Interchangeable Hitch Ball Head	—
63808	3/4" Interchangeable Hitch Ball Shank	5,000
63809	1" Interchangeable Hitch Ball Shank	8,000

* Only to be used with a 1" shank



All hitch balls built with wrench flats



63840



63880



63851



63810-006



028351

HITCH BALLS

- Solid steel hitch balls engineered to meet all safety requirements of VESC regulation V-5
- Cold forged for superior strength
- When installing hitch balls, torque all 3/4" shank dia. (B) balls to 160 ft. lbs., 1" shank dia. (B) balls to 250 ft. lbs., and 1-1/4" shank dia. (B) balls to 450 ft. lbs.

BULK HITCH BALLS

Ball Dia. A	Finish		Shank Dia. B	Shank Length C	Drawbar Thickness Range	GTW GVWR Rating
	Zinc	Chrome				
1-7/8"	63811	63810	3/4"	1-1/2"	3/8"-5/8"	2,000
1-7/8"	63813	63812	3/4"	2-3/8"	3/8"-1-3/8"	2,000
1-7/8"	-	63814	3/4"	3-3/8"	3/8"-2-1/8"	2,000
1-7/8"	63817	63816	1"	2-1/8"	3/8"-3/4"	2,000
1-7/8"	63819	63818	1"	3-3/8"	3/8"-2-1/8"	2,000
2"	63821	63820	3/4"	1-1/2"	3/8"-5/8"	3,500
2"	63823	63822	3/4"	2-3/8"	3/8"-1-3/8"	3,500
2"	-	63824	3/4"	3-3/8"	3/8"-2-1/8"	3,500
2"	63827	63826	1"	2-1/8"	3/8"-3/4"	6,000
2"	63829	63828	1"	3-3/8"	3/8"-2-1/8"	6,000
2"	63831	63830	1-1/4"	2-3/4"	3/8"-1"	8,000
2-5/16"	63833	63832	1"	2-1/8"	3/8"-3/4"	6,000
2-5/16"	63835	63834	1-1/4"	2-3/4"	3/8"-1"	12,000
2-5/16"	-	63836#	1-1/4"	2-3/4"	3/8"-1"	14,000
2-5/16"	-	63840#	1-1/4"	2-3/4"	3/8"-1"	20,000

Hitch ball requires use with like rated receiver & ball mount. Consult tow vehicle owners manual for maximum towing capacities.

PACKAGED HITCH BALLS

Ball Dia. A	Finish			Shank Dia. B	Shank Length C	Drawbar Thickness Range	GTW GVWR Rating
	Zinc	Chrome	Stainless Steel				
1-7/8"	63881	63880	-	3/4"	1-1/2"	3/8"-5/8"	2,000
1-7/8"	-	63882	-	3/4"	2-3/8"	3/8"-1-3/8"	2,000
1-7/8"	63885	63884	63851	1"	2-1/8"	3/8"-3/4"	2,000
2"	63888	63887	-	3/4"	1-1/2"	3/8"-5/8"	3,500
2"	-	63889	-	3/4"	2-3/8"	3/8"-1-3/8"	3,500
2"	63892	63891	63852	1"	2-1/8"	3/8"-3/4"	6,000
2"	-	63899	-	1-1/4"	2-3/4"	3/8"-1"	8,000
2-5/16"	63895	63894	63853	1"	2-1/8"	3/8"-3/4"	6,000
2-5/16"	63897	63896	-	1-1/4"	2-3/4"	3/8"-1"	12,000

PACKAGED HITCH BALLS (6 PACK RETAIL DISPLAY)

Ball Dia. A	Finish		Shank Dia. B	Shank Length C	Drawbar Thickness Range	GTW GVWR Rating
	Zinc	Chrome				
1-7/8"	63810-006		3/4"	1-1/2"	3/8"-5/8"	2,000
1-7/8"	63816-006		1"	2-1/8"	3/8"-3/4"	2,000
2"	63826-006		1"	2-1/8"	3/8"-3/4"	6,000
2-5/16"	63832-006		1"	2-1/8"	3/8"-3/4"	6,000

PRECISION MACHINED COUPLER BALLS

Coupler balls are precision machined from high-strength steel bars. Coupler balls are carefully shaped and are recommended for BULLDOG couplers.

- Ball diameters from 2" to 2-5/16"
- High-strength steel
- Standard configurations available for a wide variety of applications

Part No.	Rated Capacity	Description	Unit Wt. Lbs.
028375	3,000	2" with 3/4" shank	2.4
028351 ♦	5,000	2" with 1" shank	2.5
028352	7,000	2" with 1" shank (heat treated)	2.5
028400 ♦	12,500	2-5/16" with 1-1/4" shank	4

♦ DENOTES MOST POPULAR

CLASS I & II DRAWBARS

We offer ball mounts and drawbars in three separate styles: straight cut, angle cut and drop cut. Refer to the styles below to select the mount that best suits your needs.

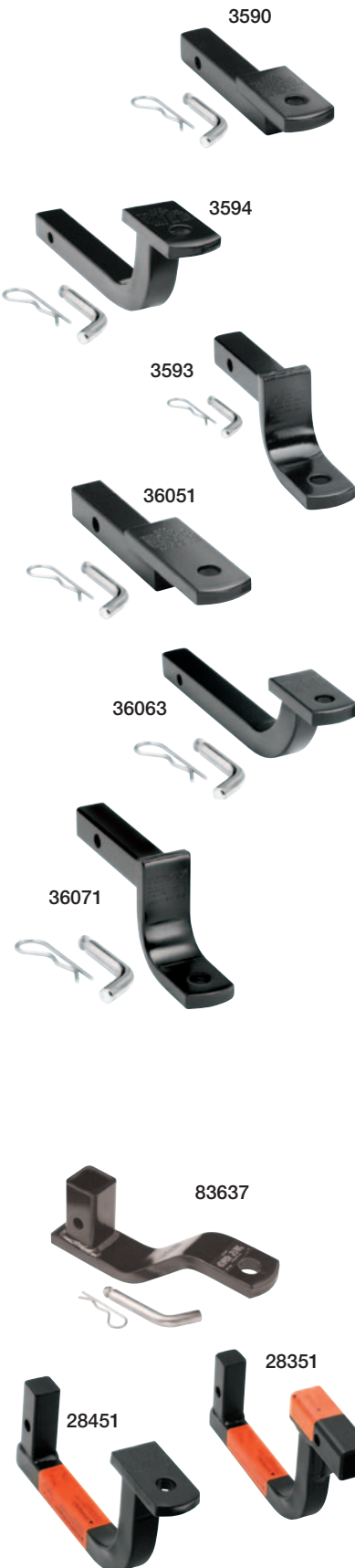

DRAWBAR TYPES

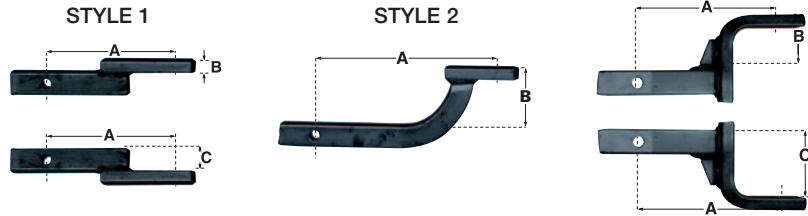

CLASS I DRAWBAR KITS

- Boxed includes drawbar, pin and clip
- Black powder coat finish over e-coat
- Fits 1-1/4" square receiver tube opening

Part No.	Rating (lbs.) GTW/TW	Ball Hole Size	A Length	B Rise	C Drop	Style
3590	2,000/200	3/4"	6-5/8"	5/8"	N/A	1
3591	2,000/200	3/4"	9-3/4"	5/8"	N/A	1
3592	2,000/200	3/4"	9-3/4"	2-1/8"	2-3/4"	3
3593	2,000/200	3/4"	6-5/8"	2-1/8"	2-3/4"	3
3594	2,000/200	3/4"	10"	4"	N/A	2

NOTE: Class I drawbar applications are specific. The correct replacement drawbar part number is listed on each Class I hitch installation instruction sheet.

CLASS II DRAWBAR KITS

- Boxed includes drawbar, pin and clip
- Black powder coat finish over e-coat
- Fits 1-1/4" square receiver tube opening

Part No.	Rating (lbs.) GTW/TW	Ball Hole Size	A Length	B Rise	C Drop	Style
36051	3,500/300	3/4"	7"	5/8"	1-1/4"	1
36053	3,500/300	3/4"	9-3/4"	5/8"	1-1/4"	1
36061	3,500/300	3/4"	9-3/4"	3-1/8"	N/A	2
36063	3,500/300	3/4"	11-3/4"	3-1/8"	N/A	2
36065	3,500/300	3/4"	10"	5"	N/A	2
36071	3,500/300	3/4"	7-3/16"	2-5/8"	3-1/4"	3
36078*	3,500/300	3/4"	7-3/8"	-	4-3/4"	3

* Fits 1-1/4" OEM Ford Explorer, Lincoln Aviator & Mercury Mountaineer hitch

NOTE: Class II drawbar applications are specific. The correct replacement drawbar part number is listed on each Class II hitch installation instruction sheet.

DRAWBAR OEM KITS

Part No.	Description
83637	Drawbar Kit for OEM Dodge Magnum hitch, 2,000 lbs. (includes pin and clip)

INVISI-HITCH™ ACCESSORIES

Part No.	Description
28451	Drawbar Kit, 2,000 lbs. (includes swivel pin)
28351	Accessory Adapter Kit (includes swivel pin)

SELECTING THE PROPER BALL MOUNT: BALL MOUNT MEASUREMENTS

LENGTH

Distance from the center of the ball hole to the center of the pin hole

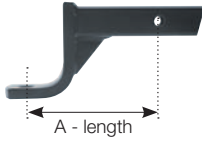

RISE

Distance from the top of the shank to the top of the ball platform



DROP

Distance from the top of the shank to the top of the ball platform

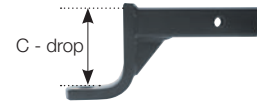

UP RATED

MAX FRAME MOUNT KITS – CLASS III/IV

- Fits 2" square receiver tube opening
- Includes pin and clip
- Black powder coat finish over e-coat

Part No.	Rating (lbs.) GTW/TW	Ball Hole Size	A Length	B Rise	C Drop	Style
2923	7,500/750	1"	8-1/2"	3/4"	2"	2
2953	6,000/600	1"	9"	2-3/4"	4"	2



**STYLE 2
ANGLE CUT**

UP RATED

EASY LOAD BALL MOUNTS

Featuring a revolutionary tapered shank design, easy-load ball mounts provide an easy connection to the receiver.

- Angle cut design
- Fits 2" square receiver tube opening
- Black powder coat finish over e-coat

Part No.	Bulk Part No.	Rating (lbs.) GTW/TW	Ball Hole Size	A Length	B Rise	C Drop	Style
40342	40342-006	7,500/750	1"	8-1/2"	3/4"	2"	2
40343	40343-006	6,000/600	1"	10-1/2"	3/4"	2"	2
40344	40344-006	6,000/600	1"	9"	2-3/4"	4"	2
40345	40345-006	6,000/600	1"	11"	2-3/4"	4"	2
40346	40346-002	6,000/600	1"	9-1/2"	4-3/4"	6"	2

Note: Pin and clip sold separately



**STYLE 3
DROP CUT**

UTILITY BALL MOUNTS

- Fits 2" square receiver tube opening
- Bulk boxed
- Black powder coat finish over e-coat

Part No.	Bulk Part No.	Rating (lbs.) GTW/TW	Ball Hole Size	A Length	B Rise	C Drop	Style
2736	2736-006	5,000/500	1"	12"	3/4"	2"	1
2793	2793-002	5,000/500	1"	10"	6-3/4"	8"	3
2706		3,500/350	1"	9"	9-3/4"	-	3
		5,000/500	1"	9"	-	11"	

Note: Pin and clip sold separately

PACKAGED ANGLED CUT BALL MOUNTS

- Fits 2" square receiver tube opening
- Includes pin and clip
- Black powder coat finish over e-coat



Part No.	Rating (lbs.) GTW/TW	Ball Hole Size	A Length	B Rise	C Drop	Style
40443	6,000/600	1"	10-1/2"	3/4"	2"	2
40446	6,000/600	1"	9-1/2"	4-3/4"	6"	2



PACKAGED CLASS III BALL MOUNTS

- Includes pin and clip
- Fits 2" square receiver tube opening



Part No.	Rating (lbs.) GTW/TW	Ball Hole Size	A Length	B Rise	C Drop	Style
80127	7,500/750	1"	8-1/2"	3/4"	2"	2
80139	6,000/600	1"	9"	2-3/4"	4"	2



STYLE 2

CLASS III BALL MOUNTS

- Black powder coat finish over e-coat
- Fits 2" square receiver tube opening



Part No.	Bulk Part No.	Rating (lbs.) GTW/TW	Ball Hole Size	A Length	B Rise	C Drop	Style
80227	80227-006	7,500/750	1"	8-1/2"	3/4"	2"	2
80226	80226-006	6,000/600	1"	10-1/2"	3/4"	2"	2
80232		6,000/600	1"	16"	3/4"	2"	2
80239*	80239-006*	6,000/600	1"	9"	2-3/4"	4"	2
80228	80228-006	6,000/600	1"	11"	2-3/4"	4"	2
80233		6,000/600	1"	16"	2-3/4"	4"	2
80240*		6,000/600	1"	9-1/2"	4-3/4"	6"	2
80213*	80213-002*	5,000/500	1"	10"	6-3/4"	8"	3
80248		5,000/500 3,500/350	1" 1"	9" 9"	- 9-3/4"	11" -	3



STYLE 3

* Not angle cut
Note: Pin and clip sold separately



QUICK-LOADING CLASS III BALL MOUNTS

Reese quick-loading ball mounts feature a revolutionary, angle-cut design. Provides a quick and easier connection to the receiver. All ball mounts meet or exceed SAE J684 and V-5 specifications.

- Fits 2" square receiver tube opening



Part No.	Bulk Part No.	Rating (lbs.) GTW/TW	Ball Hole Size	A Length	B Rise	C Drop	Style
21341*		5,000/500	1"	12"	3/4"	2"	1
21342	21342-006	7,500/750	1"	8-1/2"	3/4"	2"	2
21343	21343-006	6,000/600	1"	10-1/2"	3/4"	2"	2
21344	21344-006	6,000/600	1"	9"	2-3/4"	4"	2
21345	21345-006	6,000/600	1"	11"	2-3/4"	4"	2
21346	21346-002	6,000/600	1"	9-1/2"	4-3/4"	6"	2
21347*		5,000/500	1"	10"	6-3/4"	8"	3
21348*		5,000/500 3,500/350	1" 1"	9" 9"	- 9-3/4"	11" -	3



21343

21346

* Not angle cut
Note: Pin and clip sold separately



HITCH & TRAILER ALIGNMENT TOOL

- Convenient one person hitch alignment system
- Magnetic base for fast and easy location
- Telescoping rods adjust up to 42"
- Easy to use the first time



Part No.	Description
63300	Hitch & Trailer Alignment Tool



UP RATED ▶ SOLID FORGED BALL MOUNTS

- Solid one-piece forged construction
- 1" thick x 3" wide ball platforms
- Angled, easy-load design
- Black powder coat finish over e-coat
- Fits 2" square receiver tube opening



Part No.	Rating (lbs.) GTW/TW	Ball Hole Size	A Length	B Rise	C Drop
40330	16,000/2,400	1-1/4"	8-1/2"	1"	2"
40330-002 (2 pack)	16,000/2,400	1-1/4"	8-1/2"	1"	2"
40331	16,000/2,400	1-1/4"	9-1/4"	3"	4"
40331-002 (2 pack)	16,000/2,400	1-1/4"	9-1/4"	3"	4"
40332	16,000/2,400	1-1/4"	10-1/4"	5"	6"
40332-002 (2 pack)	16,000/2,400	1-1/4"	10-1/4"	5"	6"



Part No.	Rating (lbs.) GTW/TW	Ball Hole Size	A Length	B Rise	C Drop
80142	16,000/2,400	1-1/4"	8-1/2"	1"	2"
80143	16,000/2,400	1-1/4"	9-1/4"	3"	4"
80144	16,000/2,400	1-1/4"	10-1/4"	5"	6"



Part No.	Rating (lbs.) GTW/TW	Ball Hole Size	A Length	B Rise	C Drop
21330	16,000/2,400	1-1/4"	8-1/2"	1"	2"
21331	16,000/2,400	1-1/4"	9-1/4"	3"	4"
21332	16,000/2,400	1-1/4"	10-1/4"	5"	6"

ALUMINUM SOLID FORGED BALL MOUNTS

- Solid one-piece forged construction
- 1" thick x 3" wide ball platforms
- Aluminum finish
- Fits 2" square receiver tube opening



Part No.	Rating (lbs.) GTW/TW	Ball Hole Size	A Length	B Rise	C Drop
40381	8,000/800	1"	9-7/8"	1"	2"
40382	8,000/800	1"	10-5/8"	3"	4"
40383	8,000/800	1"	11-7/8"	5"	6"
40384	6,000/600	1"	10-7/8"	7"	8"



Part No.	Rating (lbs.) GTW/TW	Ball Hole Size	A Length	B Rise	C Drop
21381	8,000/800	1"	9-7/8"	1"	2"
21382	8,000/800	1"	10-5/8"	3"	4"
21383	8,000/800	1"	11-7/8"	5"	6"
21384	6,000/600	1"	10-7/8"	7"	8"

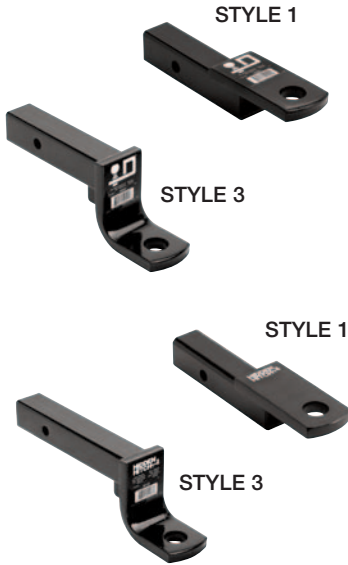

ULTRA FRAME® HOLLOW SHANK BALL MOUNTS

- Black powder coat finish over e-coat
- Fits 2" square receiver tube opening



Part No.	Rating (lbs.) GTW/TW	Ball Hole Size	A Length	B Rise	C Drop	Style
40200	10,000/1,000	1-1/4"	8-1/2"	3/4"	2"	1
40201	10,000/1,000	1-1/4"	9"	2-3/4"	4"	3
40202	10,000/1,000	1-1/4"	11-1/4"	2-3/4"	4"	3
40205	10,000/1,000	1-1/4"	9"	-	6"	3
40206	10,000/1,000	1-1/4"	9"	-	8"	3



Part No.	Rating (lbs.) GTW/TW	Ball Hole Size	A Length	B Rise	C Drop	Style
80132	10,000/1,000	1-1/4"	8-1/2"	3/4"	2"	1
80133	10,000/1,000	1-1/4"	9"	2-3/4"	4"	3
80136	10,000/1,000	1-1/4"	11-1/4"	2-3/4"	4"	3
80137	10,000/1,000	1-1/4"	9"	-	6"	3
80138	10,000/1,000	1-1/4"	9"	-	8"	3

ULTRA FRAME® SOLID SHANK BALL MOUNTS

- Fits 2" square receiver tube opening
- Durable zinc coated finish



Part No.	Rating (lbs.) GTW/TW	Ball Hole Size	A Length	B Rise	C Drop	Style
4280	12,000/1,200	1-1/4"	8-1/2"	1"	2"	1
4284	12,000/1,200	1-1/4"	12"	1"	2"	1
4281	12,000/1,200	1-1/4"	8-1/2"	3"	4"	3
4285	12,000/1,200	1-1/4"	12"	3"	4"	3
4282	12,000/1,200	1-1/4"	9-1/2"	5"	6"	3
4283	12,000/1,200	1-1/4"	9-1/2"	7"	8"	3



Part No.	Rating (lbs.) GTW/TW	Ball Hole Size	A Length	B Rise	C Drop	Style
80122	12,000/1,200	1-1/4"	8-1/2"	1"	2"	1
80123	12,000/1,200	1-1/4"	8-1/2"	3"	4"	3
80126	12,000/1,200	1-1/4"	12"	3"	4"	3
80124	12,000/1,200	1-1/4"	9-1/2"	5"	6"	3
80125	12,000/1,200	1-1/4"	9-1/2"	7"	8"	3

TITAN® BALL MOUNTS

- Fits 2-1/2" square receiver tube opening, for use exclusively with Titan® receivers
- Black powder coat finish over e-coat



Part No.	Rating (lbs.) GTW/TW	Ball Hole Size	A Length	B Rise	C Drop	Style
45122	14,000/1,400	1-1/4"	9-3/4"	1-1/2"	3"	3
45123	13,000/1,300	1-1/4"	10"	3-1/2"	5"	3
45291	13,000/1,300	1-1/4"	10-1/2"	-	7-3/4"	3
45322	18,000/2,000	1-1/4"	10"	1-1/2"	3"	3
45323	18,000/2,000	1-1/4"	10"	3-1/2"	5"	3



CUSHIONED BALL MOUNTS



These ball mounts feature two heavy-duty polyurethane cushions in the rear retainer to reduce the “slams” and “bangs” associated with trailer towing during starting, stopping and rough highways. Reducing these jolts helps to protect your towing vehicle’s driveline, hitch assembly and trailer contents. Cushioned ball mounts act as a shock absorber and fits 2” square receiver tube opening.

Part No.	Rating (lbs.) GTW/TW	Ball Hole Size	A Length	B Rise	C Drop
80420	10,000/1,000	1”	9-3/8”	3/4”	2”
80421	10,000/1,000	1”	9-7/8”	2-3/4”	4”
80422	10,000/1,000	1”	10-5/8”	4-3/4”	6”



CLASS III INTERLOCK TOWING STARTER KITS

- Includes 2” hitch ball
- Includes receiver lock
- Black powder coat finish over e-coat
- Fits 2” square receiver tube opening



Part No.	Rating (lbs.) GTW/TW	A Length	B Rise	C Drop	Secure
40565	6,000/600	8-1/2”	3/4”	2”	Lock



Part No.	Rating (lbs.) GTW/TW	A Length	B Rise	C Drop	Secure
80565	6,000/600	8-1/2”	3/4”	2”	Lock



Part No.	Rating (lbs.) GTW/TW	A Length	B Rise	C Drop	Secure
83565	6,000/600	8-1/2”	3/4”	2”	Lock



CLASS III STANDARD TOWING STARTER KITS (2-PACK)

- Point of purchase retail display
- Two kits per display box
- Fits 2” square receiver tube opening
- Includes pin and clip
- Black powder coat finish over e-coat (except 40567-002 w/Chrome Ball Mount)



Part No.	Rating (lbs.) GTW/TW	A Length	B Drop	C Ball Size	Secure
40563-002	6,000/600	8-1/2”	2”	2”	Pin/Clip
40567-002	6,000/600	8-1/2”	2”	2”	Pin/Clip
40566-002	6,000/600	9”	4”	2”	Pin/Clip



Part No.	Rating (lbs.) GTW/TW	A Length	B Drop	C Ball Size	Secure
80563-002	6,000/600	8-1/2”	2”	2”	Pin/Clip
80570-002	6,000/600	9”	4”	2”	Pin/Clip



Part No.	Rating (lbs.) GTW/TW	A Length	B Drop	C Ball Size	Secure
83563-002	6,000/600	8-1/2”	2”	2”	Pin/Clip
83570-002	6,000/600	9”	4”	2”	Pin/Clip



ADJUSTABLE BALL MOUNTS

Adjustable ball mounts are perfect for those who tow multiple trailers of varying coupler heights.

- Fits 2" square receiver tube opening, shank can be used in rise or drop position



6580

HOLLOW SHANK BALL MOUNT

- Rated at 6,000 lbs. GTW/600 lbs. TW
- Quick release pin and clip for maximum adjustability
- Black powder coat finish over e-coat



Part No.	Description	Length	Max. Rise	Max. Drop
6580	Complete Shank and Head Assembly with quick release pin and clip	12"	6-1/8"	7-3/8"



1420
1422
1424

SOLID SHANK BALL MOUNTS

- Rated at 5,000 lbs. GTW/500 lbs. TW
- Black powder coat finish over e-coat



Part No.	Description	Length	Max. Rise	Max. Drop
1420	Complete Shank and Head Assembly	12"	6"	7-1/4"
1422	Complete Shank and Head Assembly	14"	6"	7-1/4"
1424	Complete Shank and Head Assembly	16"	6"	7-1/4"

NOTE: Hitch ball, pin (55010) and clip (55515) sold separately. Not interchangeable with weight distribution replacement parts.



7390

HOLLOW SHANK BALL MOUNT WITH SWAY CONTROL TAB

- Rated at 6,000 lbs. GTW/600 lbs. TW
- Platform mounts for left or right hand sway control



Part No.	Description	Length	Max. Rise	Max. Drop
7390	Complete Shank and Head Assembly	12"	3-3/4"	5-1/4"

NOTE: Hitch ball, pin (55010) and clip (55515) sold separately. Not interchangeable with weight distribution replacement parts.



80412
80414

HOLLOW SHANK BALL MOUNTS

- Rated at 6,000 lbs. GTW/600 lbs. TW
- Quick release pin and clip for maximum adjustability



Part No.	Description	Length	Max. Rise	Max. Drop
80412	Adjustable Ball Mount, display pkg	12"	8-3/8"	9-5/8"
80414	Adjustable Ball Mount, bulk	14"	8-3/8"	9-5/8"
80417	Shank only (12" Length)			
80418	Ball Mount Plate only			



21141

BALL MOUNT

- Adjustable utility draw features 5,000 lbs. GTW/500 lbs. TW rating and 13-3/4" height adjustment capacity
- Quick release pin and clip for maximum adjustability



Part No.	Description	Length	Max. Rise	Max. Drop
21141	Adjustable Ball Mount	13-12"	6-1/4"	7-1/2"



7627

6352

HITCH BALL & BALL MOUNT BAGS

- Conveniently stores interchangeable and removable hitch balls when not in use
- Durable nylon with hook & loop closure to secure ball and keep vehicle clean

Part No.	Description
7627	Ball Mount Bag (ball mount not included)
6352	Hitch Ball Bag (hitch ball not included)

REVERSIBLE BALL MOUNTS

Reversible ball mounts are perfect for those who tow multiple trailer with varying ball diameters. Weight rating as per ball being used.



38180

SUPER TITAN® DUAL-BALL MOUNT

- Fits 3" square receiver tube opening, designed for Super Titan® Receivers
- Includes 2" (17,000 lbs.) & 2-5/16" (25,000 lbs.) hitch balls
- 9" Length



Part No.	Description
38180	Super Titan® Dual-Ball Mount (2" & 2-5/16")



45325

TITAN® TRI-BALL HOLLOW SHANK

- Fits 2-1/2" square receiver tube opening, designed for Titan® Receivers



Part No.	Description	Rating (lbs.) GTW/TW	Shank Length	Ball Size
45325	Titan® Tri-Ball Mount, Black Balls	2,000/200	8-3/4"	1-7/8"
		10,000/1,000	8-3/4"	2"
		14,000/1,400	7-1/2"	2-5/16"

DUAL-BALL / TRI-BALL SOLID SHANK

- Fits 2" square receiver tube opening



80795
80796



80797
80798



80791

80799

Part No.	Description	Rating (lbs.) GTW/TW	Shank Length	Ball Size
80795	Dual-Ball Mount, Black Balls, Black Solid Shank	2,000/200	8"	1-7/8"
		10,000/1,000	8"	2"
80796	Dual-Ball Mount, Black Balls, Black Solid Shank	10,000/1,000	8"	2"
		16,000/1,600	8"	2-5/16"
80797	Dual-Ball Mount, Chrome Balls, Black Solid Shank	2,000/200	8"	1-7/8"
		10,000/1,000	8"	2"
80798	Dual-Ball Mount, Chrome Balls, Black Solid Shank	10,000/1,000	8"	2"
		16,000/1,600	8"	2-5/16"
80791	Tri-Ball Mount, Black Balls, Black Solid Shank	2,000/200	8"	1-7/8"
		10,000/1,000	8"	2"
		16,000/1,600	6-3/4"	2-5/16"
80799	Tri-Ball Mount, Chrome Balls, Black Solid Shank	2,000/200	8"	1-7/8"
		10,000/1,000	8"	2"
		16,000/1,600	6-3/4"	2-5/16"

DUAL-BALL HOLLOW SHANK

- Fits 2" square receiver tube opening



80404
80405
80406

Part No.	Description	Rating (lbs.) GTW/TW	Ball Size	Position
80404	Dual-Ball Mount, Black Hollow Shank	2,000/200	1-7/8"	Rise
		6,000/600	2"	Drop
80405	Dual-Ball Mount, Black Hollow Shank	2,000/200	1-7/8"	Drop
		6,000/600	2"	Rise
80406	Dual-Ball Mount, Black Hollow Shank	6,000/600	2"	Drop
		6,000/600	2-5/16"	Rise

TRI-BALL HOLLOW SHANK

- Fits 2" square receiver tube opening



80425

80426

Part No.	Description	Rating (lbs.) GTW/TW	Shank Length	Ball Size
80425	Tri-Ball Mount, Black Balls, Black Hollow Shank	2,000/200	8"	1-7/8"
		6,000/600	8"	2"
		10,000/1,000	6-3/4"	2-5/16"
80426	Tri-Ball Mount, Chrome Balls, Black Hollow Shank	2,000/200	8"	1-7/8"
		6,000/600	8"	2"
		10,000/1,000	6-3/4"	2-5/16"



BUMPER GUARD, "THE HITCH GUIDE-AND-STOP"

- Protects vehicle from coupler impact while backing up
- Mounts to any ball mount with 1" hole



Part No.	Description
80400	Bumper Guard, black
80470	Bumper Guard, diamond plate



HITCH BALL WRENCH



Part No.	Description
74342	Hitch Ball Wrench, boxed end 1-1/8" & 1-1/2"



REDUCER BUSHING

- Allows 3/4" shank hitch balls to be used in ball mounts with 1" hole
- Allows 1" shank hitch balls to be used in ball mounts with 1-1/4" hole

Part No.	Description
80100	Reducer Bushing, 1" OD to 3/4" ID
80106	Reducer Bushing, 1-1/4" OD to 1" ID

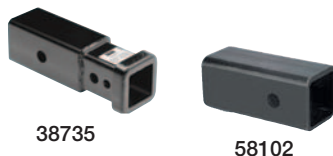

REDUCER SLEEVE



- Reduces 3" or 2-1/2" square receiver tube opening to 2"

Part No.	Description
38735	Super Titan® Reducer Sleeve, reduces 3" square receiver tube opening to 2"
58102	Titan® Reducer Sleeve, reduces 2-1/2" square receiver tube opening to 2"

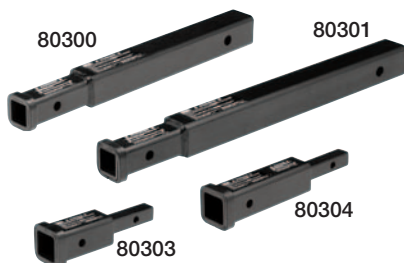

RECEIVER ADAPTERS



- Ideal for cargo carriers & bike carriers
- Designed to extend the receiver opening from 6" to 18"
- Use of this adapter reduces hitches' tow rating by 50% & with a maximum rating of 3,500 lbs towing capacity

Part No.	Description
80300	Adapts 2" to 1-1/4", 7" long, 3,500 lbs.
80301	Adapts 2" to 1-1/4", 14" long, 3,500 lbs.
80303	Adapts 1-1/4" to 2", 6" long, for Class II only; 3,500 lbs.
80304	Adapts 1-1/4" to 2", 10" long, for Class II only; 3,500 lbs.



RECEIVER EXTENSIONS



- Ideal for slide-out campers with extended overhangs
- Designed to extend the receiver opening 14", 18", 24", 34", 41" or 48"
- 2" square tube opening for use with ball mounts and hitch-mounted accessories
- Integrated electrical bracket attached (45292, 45018 only)

Part No.	Description	WC (lbs.)	WD (lbs.)	Length
80307	Receiver Extension	3,500	-	8"
80305	Receiver Extension	3,500	-	14"
80306	Receiver Extension	3,500	-	18"
11003	Receiver Extension	4,000	6,500	14"
11004	Receiver Extension	4,000	6,500	18"
11005	Receiver Extension with Step	4,000	6,500	14"
11006	Receiver Extension with Step	4,000	6,500	18"
45292	Titan® Receiver Extension (For Titan 2-1/2" receivers)	6,000 4,500	8,000 6,000	24" 34"
45018	Titan® Receiver Extension (For Titan 2-1/2" receivers)	5,000 4,000	7,500 6,000	41" 48"

WHAT'S YOUR WORKLOAD? We'll Hook You Up

PLATE MOUNTED



PINTE HOOK MOUNTING PLATE



LUNETTE RING



LUNETTE RING



DROP FORGED PINTE HITCH & BALL COMBINATION



DROP FORGED RIGID PINTE HOOK

PINTE HOOK COMBINATION



5-TON PINTE HOOK

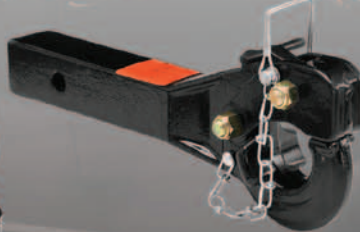

TOW EYELET



TOW HOOK



RECEIVER MOUNTED



TOW RING



TOW HOOK



PINTLE RECEIVER HOOKS

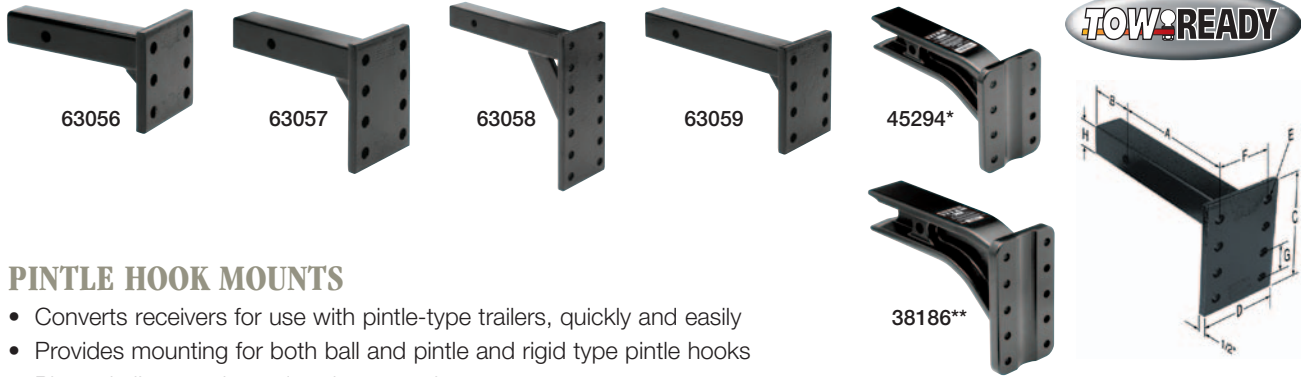

PINTLE HOOK MOUNTS

- Converts receivers for use with pintle-type trailers, quickly and easily
- Provides mounting for both ball and pintle and rigid type pintle hooks
- Pin and clip must be ordered separately

Part No.	Shank	Rating (lbs.) GTW/TW	A Shank	B Length	H Shank Dia.	C Height	D Width	E Hole	F Width	G Height	Hole Sets
63056	Hollow	6,000/600	7-5/8"	3"	2"	5-1/2"	5"	17/32"	3-3/8"	1-3/4"	3
63057	Solid	12,000/1,200	7-5/8"	3-1/4"	2"	7-1/2"	5"	17/32"	3-3/8"	1-3/4"	4
63058	Solid	8,000/800	11-3/8"	3-1/4"	2"	12-1/2"	5"	17/32"	3-3/8"	1-3/4"	7
63059	Solid	12,000/1,200	11-3/8"	3-1/4"	2"	7-1/2"	5"	17/32"	3-3/8"	1-3/4"	4
45156*	Hollow	12,000/1,200	7-3/4"	3-1/4"	2-1/2"	6"	5"	17/32"	3-3/8"	1-3/4"	3
45294*	Forged	18,000/2,000	8-1/2"	3-1/4"	2-1/2"	7-1/4"	5"	17/32"	3-3/8"	1-3/4"	4
38186**	Forged	25,000/4,000	9"	3-1/4"	3"	9"	5"	17/32"	3-3/8"	1-3/4"	5

*Titan® pintle hook adapter mount, **Super Titan® pintle hook adapter mount

PINTLE HOOKS

- Includes mounting hardware



63013
63014
63015
63016

Part No.	Description
63013	5 Ton, 2,000 lbs. max. vertical load, 10,000 lbs. GTW
63014	10 Ton, 4,000 lbs. max. vertical load, 20,000 lbs. GTW
63015	15 Ton, 6,000 lbs. max. vertical load, 30,000 lbs. GTW
63016	30 Ton, 14,000 lbs. max. vertical load, 60,000 lbs. GTW
63032	Replacement Hardware Mounting Kit

PINTLE HOOK COMBINATION HITCHES

- Includes mounting hardware
- 3,000 lbs. maximum vertical load, 16,000 lbs. maximum GTW when used as pintle hook



63010
63011
63012

Part No.	Description
63010	1-7/8" Combo Hitch, 16,000 lbs. GTW, ball rating 6,000 lbs.
63011	2" Combo Hitch, 16,000 lbs. GTW, ball rating 10,000 lbs.
63012	2-5/16" Combo Hitch, 16,000 lbs. GTW, ball rating 14,000 lbs.
63032	Replacement Hardware Mounting Kit

REPLACEMENT PARTS

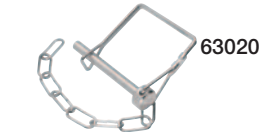

63017
63018
63019
63050
63051
63052



Part No.	Description
63050	1-7/8" Replacement Ball, 6,000 lbs., 1-1/8" diameter
63051	2" Replacement Ball, 10,000 lbs., 1-1/8" diameter
63052	2-5/16" Replacement Ball, 14,000 lbs., 1-1/8" diameter
63020	Replacement Snapper Pin, 1/4"
43031	5/16" Safety Pin
63032	Replacement Hardware Mounting Kit
63017	1-7/8" Replacement Ball, 6,000 lbs., 1-1/4" diameter
63018	2" Replacement Ball, 10,000 lbs., 1-1/4" diameter
63019	2-5/16" Replacement Ball, 14,000 lbs., 1-1/4" diameter



LUNETTE RINGS

Part No.	Description
28023	Lunette Ring Lock (fits 2-1/2" and 3" diameter lunette rings)
4210	Lunette Ring Lock
63023	Lunette Ring, 2-1/2" diameter with 4 hole base 42,000 lbs. GTW, 8,400 lbs. maximum vertical load
63033	Hardware Mounting Kit for 63023
63022	Lunette Ring, 2-1/2" diameter with 1-1/2" shank 15,000 lbs. GTW, 2,400 lbs. maximum vertical load
63036	Adjustable Lunette Ring with Channel, 3" Dia., 24,000 lbs. Capacity
63060	Adjustable Lunette Ring with Hardware, 3" Dia., 24,000 lbs. Capacity (Adjustable Channel Sold Separately)

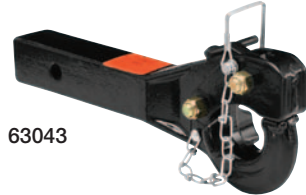

ONE-PIECE PINTLE HOOK

Part No.	Description	Max GTW	Ball GTW	Max VL
63043	5-Ton Receiver Mount Pintle Hook	10,000	-	2,000



ONE-PIECE PINTLE COMBINATIONS

Part No.	Description	Max GTW	Ball GTW	Max VL
63040	1-7/8" Receiver Mount Pintle Combination	12,000	2,000	2,400
63041	2" Receiver Mount Pintle Combination	12,000	7,000	2,400
63042	2-5/16" Receiver Mount Pintle Combination	12,000	12,000	2,400



RECEIVER MOUNT TOW EYELET

Part No.	Description
63045	Forged Receiver Mount Tow Eyelet, 10,000 lbs. GTW, 7-3/8" Length



RECEIVER MOUNT TOW HOOKS

Part No.	Description
63044	Forged Receiver Mount Tow Hook, 10,000 lbs. GTW, 7-3/8" Length
63047	Receiver Mount Tow Hook, 8,000 lbs. GTW, 7" Length



RECEIVER MOUNT TOW RING

Part No.	Description
63046	Receiver Mount Tow Ring, 8,000 lbs. GTW, 7-3/8" Length

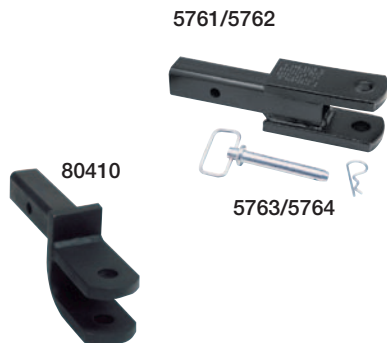

CLEVIS MOUNTS

- For use with industrial/agricultural equipment

Part No.	Description	Ball Mount GTW/TW (lbs.)	Clevis Mount GTW/TW (lbs.)	Length
5761	Clevis Mount, 3/4" hole	3,500/350	5,000/350	9-3/4"
5762	Clevis Mount, 1" hole	6,000/600	6,000/600	8-7/8"
80410*	Clevis Mount, 1" hole	6,000/600	6,000/600	11"
6201	Clevis Mount, 1" hole	6,000/600	10,000/1,000	8-7/8"
5763	Clevis Pin, 3/4" dia.			4-1/4"
5764	Clevis Pin, 1" dia.			4-3/4"

* Ball Mount has 1-1/4" drop, Clevis has 3" drop



PINS AND CLIPS

Pins and clips are included with all Class I and II hitches.



Part No.	Description
63241	Packaged Class I/II Pin & Clip, 1/2", groove style
63241-050	Class I/II Pin & Clip, 1/2", groove style (50 pack)
63240	Packaged Class III/IV Pin & Clip, 5/8", groove style
63240-050	Class III/IV Pin & Clip, 5/8", groove style (50 pack)
63242	Packaged Class III/IV Pin & Clip, 5/8", hole style
63242-050	Class III/IV Pin & Clip, 5/8", hole style (50 pack)
63242-100	Class III/IV Pin & Clip, 5/8", hole style (100 pack)
63242-500	Class III/IV Pin & Clip, 5/8", hole style (500 pack)
63243	Packaged Class V Titan® Pin & Clip, 5/8", groove style
06237	Class I/II Bulk Pin, 1/2", groove style
55010	Class III/IV Bulk Pin, 5/8", groove style
55010-050	Class III/IV Bulk Pin, 5/8", groove style (50 pack)
55515	Bulk Clip
55515-050	Bulk Clip (50 pack)

SWIVEL PINS (PACKAGED)



Part No.	Description
63202	1/2" Integral Pin and Clip, stainless
63203	5/8" Integral Pin and Clip, stainless
63204	1/2" Integral Pin and Clip, zinc
63205	5/8" Integral Pin and Clip, zinc

STABILIZING PIN WITH LOCK

More than just a hitch pin, J-Pin® quickly and confidently secures ball mounts and other hitch-mounted accessories, eliminating the sway and rattle caused by part clearance issues.

J-Pin® ready receiver design allows for the most confident and secure hookup in today's towing market by compressing the hitch-mounted accessory against the inner side wall of the hitch receiver tube. Once attached, the hitch and towing components seem virtually welded together.

Packaged complete with its integral ball mount lock, J-Pin® makes your towing system complete.



63201



J-PIN®

- For 2" receivers only
- Ideal for bike racks and hitch-mounted cargo carriers
- Attachment wrench included
- Attractive point-of-purchase packaging
- Requires hitch with additional 17/32" hole in receiver tube
- Convenient 1/4" turn key for ease of use

Part No.	Description
63201	J-Pin® Anti-Rattle Pin w/Barrel Lockset



Insert J-Pin® through large hole in receiver hitch

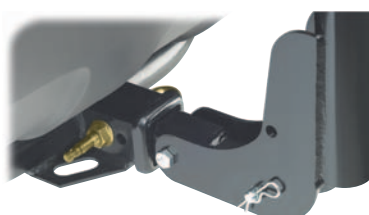

Tighten nut on J-Pin® shaft, compressing ball mount or hitch-mounted accessory against receiver tube

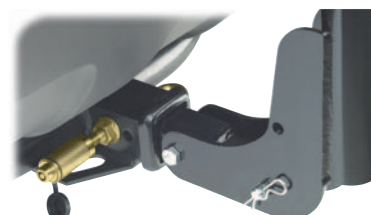

Secure ball mount or hitch-mounted accessory with locking head



BULLDOG® LIFELONG® LOCKS DELIVER TRIPLE SECURITY

- Stronger Break Resistance
- Dual Self-locking Design
- High Security Square Key Design
- Includes Dust Cap



580400



580401



580402



580403



580404

LIFELONG® HITCH LOCKS WITH 5/8" DIAMETER

Part No.	Description
580400	Chrome Bent Shank Lock for Class III & IV
580401	Chrome Dogbone Lock for Class III & IV
580402	Stainless Steel Dogbone Lock for Class III & IV

LIFELONG® TRAILER LOCK

Part No.	Description
580403	Chrome Coupler Lock

LIFELONG® COMBO LOCK

Part No.	Description
580404	Chrome Combo Lock Set, 5/8" Dogbone Receiver and Coupler, for Class III & IV



580405



580406



580407



580408



580409



580410

BULLDOG® LOCKS

- Includes Dust Cap
- Easy Access Models Feature Side Key Entry, Sliding Dust Cap, Lock Housing Rotates 360°

HITCH LOCKS WITH 5/8" AND 1/2" DIAMETER

Part No.	Description
580405	Stainless Steel Dogbone Lock w/Sleeve for 1-1/4" & 2" Square Receivers
580406	Stainless Steel Combo Lock Set, 5/8" Dogbone Lock w/Sleeve for 1-1/4" & 2" Square Receivers and Coupler
580407	Easy Access Lock w/Sleeve for 1-1/4" & 2" Square Receivers

TRAILER LOCKS

Part No.	Description
580408	Stainless Steel Coupler Lock
580409	Easy Access Long Coupler Lock
580410	Easy Access Adjustable Coupler Lock
TK100 0100	Trailer Keeper® Lock - Heavy-duty, hardened steel construction. Adjustable to fit most trailer wheels up to 15". Includes brass lock and key set.



TK100 0100



63234

HITCH LOCKS WITH 5/8" AND 1/2" DIAMETER

Part No.	Description
63234*	Dogbone Lock w/Sleeve for 1-1/4", 2" & 2-1/2" Square Receivers
63248	Bent Pin Lock w/Extra Pin for 1-1/4" & 2" Square Receivers

* not compatible with 18K Titan® Receivers

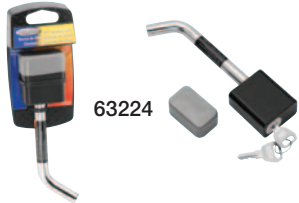

63224

HITCH LOCKS WITH 1/2" DIAMETER

Part No.	Description
63224	Bent Pin Lock for 1-1/4" Square Receivers



63223

HITCH LOCKS WITH 5/8" DIAMETER

Part No.	Description
63223	Bent Pin Lock for 2" & 2-1/2" Square Receivers
63252	Dogbone Lock for 2-1/2" Square Receivers, 3-1/2" Span, Class V
63253	Bent Pin Lock for 2-1/2" Square Receivers, 3-1/2" Span, Class V

63252



63225

63230

TRAILER LOCKS

Part No.	Description
63225	Coupler Lock
63230	Brass Coupler Lock
63226	Universal Coupler Lock
63227	Coupler Lock for 2-5/16" Ball
63228	Coupler Lock for 2" Ball



63226

63227



63228

COMBO LOCKS (HITCH, 5/8" & 1/2" DIA., AND TRAILER)



63249

63250

Part No.	Description
63249	Combo Lock Set, Bent Pin/Brass Coupler, for 1-1/4" & 2" Square Receivers
63250	Combo Lock Set, Dogbone Receiver/Coupler, for 1-1/4" & 2" Square Receivers



63232

SILENT HITCH PIN AND LOCK SYSTEM

Eliminates noise associated with hitch accessories rattling against receiver tube. Unique design holds drawtube tight inside hitch receiver tube. For use with hollow shank ball mounts only.



63145-025

Part No.	Description
63232	Class III Silent Hitch Pin, 5/8" design for 2" Square Receivers w/lock and wrench
63232-025	Class III Silent Hitch Pin, 5/8" design (25 pack)
63146	Silent Hitch Pin w/Handle and Clip, 5/8" for 2" Square Receivers
63145-025	Silent Hitch Pin w/Clip, 5/8" for 2" Square Receivers (25-pack)



KEYED ALIKE COUPLER AND HITCH LOCKS

- Avoid the complication of having to keep track of different keys for every lock
- Includes 2 keys
- Order in multiples of 3 / minimum order is 3 locks (TP20A1534 minimum is 21 locks)

Part No.	Description
63216KA	KEYED ALIKE 1/2" Receiver Lock for Class II Receiver Hitches
63217KA	KEYED ALIKE 5/8" Receiver Lock for Class III & IV Receiver Hitches
63218KA	KEYED ALIKE Class II 1/2" Receiver Lock and 1/2" Span Style Coupler Lock
63219KA	KEYED ALIKE Class III & IV 5/8" Receiver Lock and 1/2" Span Style Coupler Lock
63220KA	KEYED ALIKE 1/2" Span Style Coupler Lock
63221KA	KEYED ALIKE 2" Span Style Coupler Lock with 1/4" Pin
63222KA	KEYED ALIKE 2-1/2" Span Style Coupler Lock with 1/4" Pin
TP20A1534	KEYED ALIKE 2" Coupler Lock



TRAILER GUARDIAN LOCKS

- Helps prevent accidental decoupling
- Ability to lock and secure the trailer on the tow vehicle
- Two piece construction



Part No.	Description
63235	Single Arm Lock for 2-1/2" Wide Ball Mnt. Platform w/1" Ball Hole
63236	Dual Arm Lock for 2-1/2" Wide Ball Mnt. Platform w/1" Ball Hole
63237	Single Arm Lock for 3" Wide Ball Mnt. Platform w/1" Ball Hole
63238	Dual Arm Lock for 3" Wide Ball Mnt. Platform w/1" Ball Hole

Note: Cannot be used with some ball mounts in the rise position.



CHROME RECEIVER TUBE COVERS

Part No.	Description
5351	Receiver Tube Cover, 1-1/4" Sq., Chrome, Metal
5352	Receiver Tube Cover, 2" Sq., Chrome, Metal
80961	Receiver Tube Cover, 2" Sq., Chrome, Plastic
1944	Receiver Tube Cover, 2" Sq., Chrome, Plastic

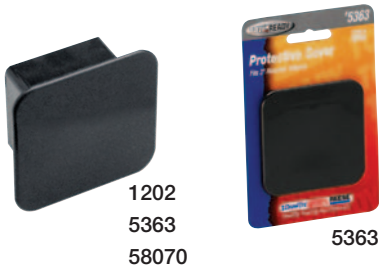

RECEIVER TUBE COVERS

Part No.	Description
58070	Receiver Tube Cover, 1-1/4" Sq., Black, Nylon (24 pack)
1202	Receiver Tube Cover, 2" Sq., Black
01202-024	Receiver Tube Cover, 2" Sq., Black (24 pack)
5363	Receiver Tube Cover, 2" Sq., Black, Plastic (1202 with Header Card)



RUBBER RECEIVER TUBE COVERS W/"D" LOGO

Part No.	Description
5362	Rubber Receiver Tube Cover, 1-1/4" Sq. w/"D" logo with Header Card
2211	Rubber Receiver Tube Cover, 1-1/4" Sq. w/"D" logo (bulk)
7050	Rubber Receiver Tube Cover, 2" Sq. w/"D" logo with Header Card
7010	Rubber Receiver Tube Cover, 2" Sq. w/"D" logo (bulk)
07010-024	Rubber Receiver Tube Cover, 2" Sq. w/"D" logo (24-pack)



RUBBER RECEIVER TUBE COVERS W/"HIDDEN HITCH" LOGO

Part No.	Description
60037	Class I/II Cover, rubber 1-1/4" Sq. with Header Card
60037-024	Class I/II Cover, rubber 1-1/4" Sq. (24 pack)
80037	Class III Cover, rubber 2" Sq. with Header Card
80037-012	Class III Cover, rubber 2" Sq. (12 pack)



"HITCH HIDER" RUBBER TUBE COVER

- Securely attaches to any 2" receiver tube
- Rubber construction tightly seals tube opening
- Built-in 4-way flat electrical cover

Part No.	Description
5330	Class III Cover, black rubber
05330-010	Class III Cover, black rubber (10 pack)



80953

PLASTIC COVERS

- Provides custom finish
- Impact resistant construction



Part No.	Description
80953	Class III Cover, plastic

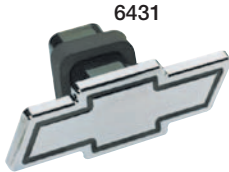

6431



6432

LOGO RECEIVER TUBE COVERS

- Attractive point-of-purchase packaging
- Foam gasket included for exact fit
- Heavy chrome face features popular OEM manufacturer logos
- OEM licensed

6433



Part No.	Description
6431	Chevrolet logo, fits all 2" receivers
6432	Dodge Ram logo, fits all 2" receivers
6433	Ford oval logo, fits all 2" receivers

74099



74547



45144

RECEIVER TUBE COVERS W/"REESE" LOGO

- Attractive point-of-purchase packaging
- Foam gasket included for exact fit
- Heavy chrome face features popular OEM manufacturer logos
- OEM licensed

Part No.	Description
74099	Receiver Tube Cover, 2" Sq., w/"Reese" logo
74547	Receiver Tube Cover, 2" Sq., w/"Reese" logo
45144	Titan® Receiver Tube Cover, 2-1/2" Sq., W/"Reese" logo

80980

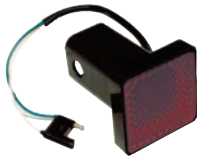

BRAKE LIGHT COVER

This handy cover doubles as an additional brake light. It plugs into a 4-way flat connector and lights up with turn and brake functions.

Part No.	Description
80980	Brake Light Cover, Class III

42250-012



42250



HITCH BALL COVER



Part No.	Description
42250	Hitch Ball Cover 1-7/8" - 2"
42250-012	Hitch Ball Cover Display Pack 1-7/8" - 2" (12 pack)
42251	Hitch Ball Cover 2-5/16"
42251-012	Hitch Ball Cover Display Pack 2-5/16" (12 pack)

CUSTOM WIRE HARNESSSES

Bargman® and Wesbar®, with a 40 year reputation in wire harnesses, now offers a complete custom wire harness design and assembly service. Whether your requirements are for single pole assemblies or complex multi-connection harnesses, Cequent Performance Products is ready to work with you in the development and manufacture of cost effective custom wire and harness assemblies built to your specifications.

Contact your Cequent representative for requirements and minimum annual quantities. Our capabilities and wire features include:

- Braiding
- Vinyl sleeving
- PVC molding
- Overmolding
- Heat shrink insulating
- Terminating
- Harness tying
- Color coding
- Optional number coding
- Special packaging
- Special labeling
- Build to forecast
- Build to print
- Build to AVL
- Quick turn capability
- Superior quality

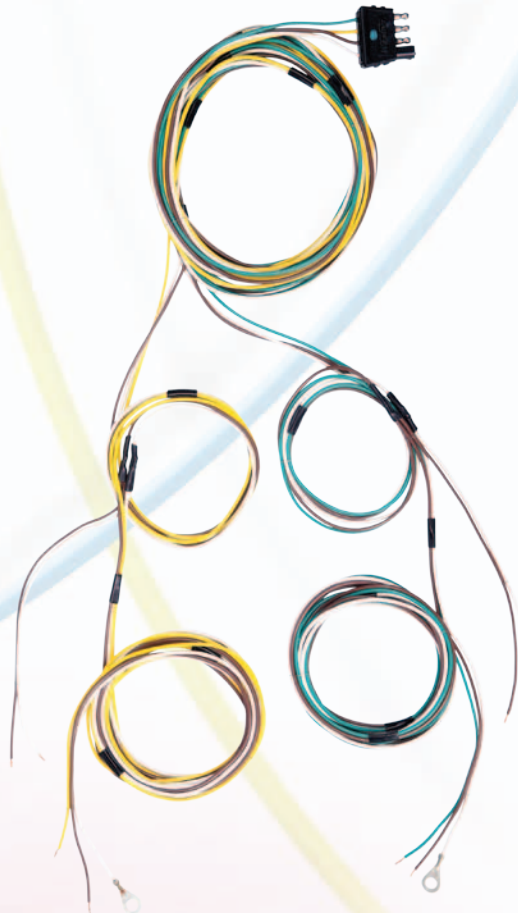

T-ONE® CONNECTORS

T-One® Connectors
T-One® Application Guide

MODULITE® POWER MODULES / CONVERTERS

ModuLite® Power Modules
Taillight Converters
Multi-Fit Wiring Harness

4-WAY FLAT CONNECTORS & WIRING

4-Way Flat Wire Harnesses
4-Way Round Pin Connectors
4-Way Flat Knockout Connector
4-Way Flat Connectors w/Jacketed Cable

2-WAY FLAT CONNECTORS & WIRING

2-Way Flat Wire Harnesses

DUST COVERS

4-Way /5-Way Flat Dust Covers

5-WAY FLAT CONNECTORS & WIRING

5-Way Flat Wire Harnesses

6-WAY ROUND PIN / SQUARE CONNECTORS & WIRING

6-Way Metal / Zinc Die Cast Connectors
6-Way Square Connectors
6-Way Super Sealed Car Ends with Cable
6-Way Molded Trailer End Connectors with Cable
6-Way / 7-Way Trailer Extensions

7-WAY RV BLADE CONNECTORS & WIRING

7-Way Thermo-Plastic / Metal Connectors
7-Way Super Sealed Car Ends with Cable
7-Way Molded Trailer End Connectors with Cable
7-Way Cold Weather Molded Trailer End Connectors with Cable
7-Way 90° Molded Plug with Cable / Application Chart
7-Way US Car Pre-Wired Cables
7-Way Trailer Extensions / Replacement Kit

7-WAY ROUND PIN AG / TRAILER CLOCKING CONNECTORS & WIRING

7-Way Round Pin AG Connectors
7-Way Molded Trailer End Connectors with Cable - Trailer Clocking
Magnet Kit / Tandem Haul Adapter
AG Light Enhanced Lighting Modules /
AG Extension Harnesses
AG Lighting

VEHICLE / TRAILER ADAPTERS/JUMPERS

Vehicle / Trailer Adapters/Jumpers

ELECTRICAL ACCESSORIES

Connector Mounting Brackets / Boxes
Junction / Breaker Boxes
Heavy Duty Flashers
Primary Wire
Wiring / Hardware Components
Circuit Breakers
Dielectric Silicone Compound / Grease / Tape

AG LIGHTING - TECHNICAL

AG Lighting - Technical

WIRING DIAGRAMS

7-Way Wiring Diagram
6-Way Wiring Diagram
5-Way Wiring Diagram
4-Way Wiring Diagram



With more than **277** products covering over **4,319** vehicle applications, **Tow Ready®** is pleased to offer the widest coverage of **T-One® Connectors** in the industry.

T-ONE® CONNECTORS

T-One® Connectors require no splicing of vehicle wires. Simply locate your vehicles wiring harness connector, unplug the connection and insert the T-One® Connector into the vehicle's harness. No special tools required.

- "Factory" appearance
- Quick and easy installation
- Solid, weatherproof, one-piece construction
- No cutting, splicing or taping of vehicle wires
- Includes converter where needed
- 16 gauge bonded wire with 4-Flat plug & cap
- Just plug in the T-One® Connector and you're ready to tow
- Simple do-it-yourself instructions in every package
- Attractive Point-of-Purchase Packaging
- 1 year limited warranty

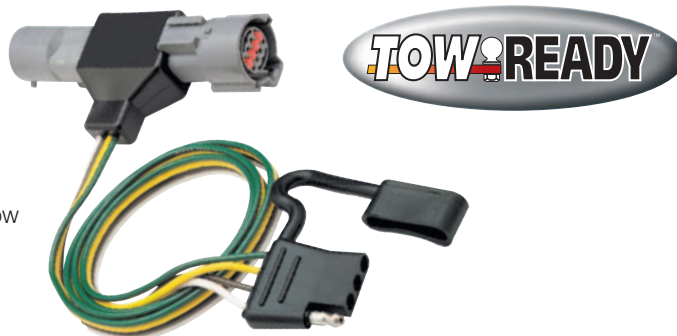

SIMPLY UNPLUG EXISTING VEHICLE HARNESS, PLUG T-ONE CONNECTOR IN...

1. Locate



2. Unplug



3. Plug in



And you're ready to go!...

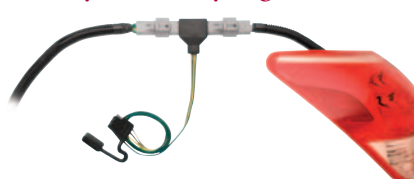

REPLACEMENT FACTORY TOW PACKAGE WIRING HARNESSES

- Exact replacement for damaged factory wiring harnesses
- Installs in seconds on vehicles not factory pre-wired
- Upgrades vehicles from 4-Flat factory wiring to 6 or 7-Way connectors
- Connects directly to standard factory connector
- Attractive point-of-purchase packaging

LOW SIDE SWITCHING T-ONE® CONNECTORS

To support the introduction of more & more computer systems in today's newer vehicles, auto makers have begun to implement a partial Multiplex Wiring System in select 1999 and newer models. In an effort to minimize system interference, a "Low-Side" switched system is being utilized. This 3 wire system (separate brake and turn lamps) is a 12 volt negative ground system, except the ground circuit is switched on and off rather than the positive as in conventional wiring systems. Standard trailer wiring systems and conventional probing methods will not work on these low side systems as the wiring to the tow vehicle bulbs is always "hot".

Tow Ready® offers a T-One® product to support this revolutionary low side wiring system. This unit uses a direct connection to the tow vehicles battery to power the trailer lights. Low side switched vehicles are identified in the hitch application section by an electrical type "G".

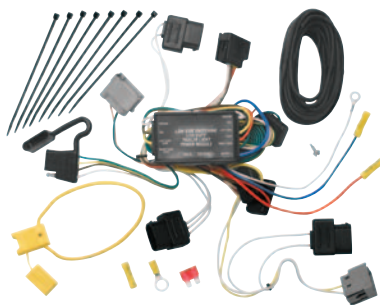



MULTI-PLUG T-ONE® CONNECTOR

- Ability to tow trailers with different style trailer connectors
- Durable plastic shell
- Weather tight seal
- Attractive point-of-purchase packaging



20119



20135

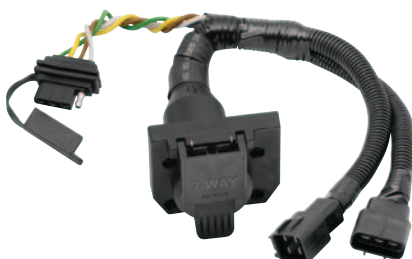

20137

Part No.	Description	Packaging
20119	7/4-Way Multi-Plug T-One® Connector (See Application Guide For Fit Information)	Clam - Tow Ready
20135	7/4-Way Multi-Plug T-One® Connector (See Application Guide For Fit Information)	Clam - Tow Ready
20137	7/4-Way Multi-Plug T-One® Connector (See Application Guide For Fit Information)	Clam - Tow Ready

118015

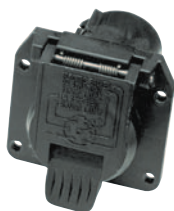

20047

7-WAY U.S. CAR ELECTRICAL CONNECTORS

- Replacement for O.E.M. Connectors
- Durable plastic shell
- Weather tight seal

Part No.	Description	Packaging
118015	7-Way U.S. Car Connector (car end) (See Application Guide for fit information)	Clam - Tow Ready
20047	7-Way U.S. Car Connector (car end) (See Application Guide for fit information)	Clam - Tow Ready

Note: Use Installation Bracket 20212



T-ONE® APPLICATION REFERENCE KEY

The following keys have been designed to clarify the T-One® application section components. Refer to the chart sample below and the corresponding numbers and illustrations on the following page.

MAKE/MODEL	YEAR	ELEC	POS	T-ONE (4-Flat)					OEM Replacement					
				PC	Part No.	FN	CP	Amp	IN	PC	Part No.	FN	TYPE	CP
ACURA														
CL Series	97-03	B	PC3	E5	118336	HG		2.1,5	5					

1 Vehicle Make, Model & Year Range

Applications are separated first by make, and subsequently by model and yearly divisions.

2 Electrical Type

Electrical type codes assist in determining the proper electrical wiring products for the towing vehicle.

3 Electrical Position

The reference locations illustrated on the following page are designed to assist you in locating the vehicle's wiring during hitch and electrical wiring installation.

4 Price Codes

Price codes reference specific prices found on Hitch and Accessory Price List.

5 Part Numbers

Part numbers are listed here of each T-One® Connector.

6 Circuit Protection

Tow Ready recommends circuit protection on vehicles with 3 wire systems for extra safety.

7 Footnotes

Footnotes reference additional information pertinent to the installation. Additional Footnotes are printed on the inside back cover of catalog.

8 Amperage Rating

Amp Rating references the maximum number of amps the Electrical Product will hold for the tow vehicle.

Stop-Turn Lights - 2 Amps Each

Taillights - 1 Amp Each

Clearance and Marker Lights - 1/4 to 1/2 Amp Each

9 Installation Time

Average installation times (IN) are listed in minutes and are published for all T-One® wiring connectors. Times are based on common mechanical practices and should be used as an estimate as actual installation times may vary in each individual situation.

10 Oem Connector Type

OEM connector type references the type of connector. Example: 4-Flat.

ELECTRICAL POSITIONS

Passenger Cars (PC)

Passenger car wiring positions are referenced by the letters **PC** and a number. Use the illustration to identify the wiring location for all passenger cars.

PC1 - Behind driver side taillight - externally

PC2 - Behind passenger side taillight - externally

PC3 - Inside trunk behind driver side taillight - internally

PC4 - Inside trunk behind passenger side taillight - internally

PC5 - Under vehicle, driver side

PC6 - Under vehicle, center

PC7 - Under vehicle, passenger side

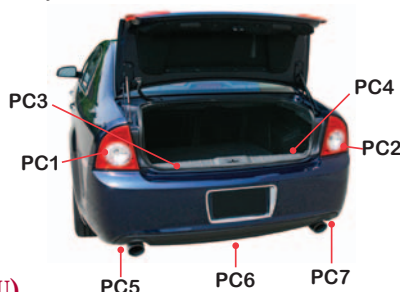

Pickup Trucks, Full & Mid-Size (PU)

Pickup truck wiring positions are referenced by the letters **PU** and a number. Use the illustration to identify the wiring location for all trucks.

PU1 - Behind driver side taillight

PU2 - Behind passenger side taillight

PU3 - Under vehicle, driver side

PU4 - Under vehicle, passenger side



Sport Utility, Van & Mini-Vans (SUV)

Sport utility, vans & mini-van wiring positions are referenced by the letters **SUV** and a number. Use the illustration to identify the wiring location for all sport utility vehicles, vans and mini-vans.

SUV1 - Behind driver side taillight

SUV2 - Behind passenger side taillight

SUV3 - Behind driver side trim panel

SUV4 - Behind passenger side trim panel

SUV5 - Under vehicle, driver side

SUV6 - Under vehicle, center

SUV7 - Under vehicle, passenger side

SUV8 - Inside vehicle, center

SUV9 - Inside vehicle, passenger side, behind panel near rear seat

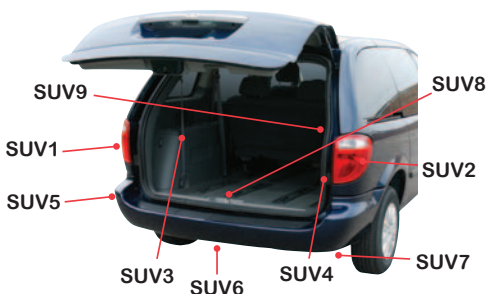



MAKE/MODEL	YEAR	ELEC	POS	T-ONE (4-Flat)					OEM Replacement						
				PC	Part No.	FN	CP	Amp	IN	PC	Part No.	FN	TYPE	CP	Amp
ACURA															
CL Series	97-03	B	PC3	E5	118336	HG		2.1,5	5						
Integra	94-01	B	PC3	E5	118336	HG		2.1,5	5						
MDX	01-06	B	SUV3	E5	118336	HG		2.1,5	10						
	07-11	W	SUV3	E11	118424	CH	X	2.1,4,2	20						
RDX	07-09	W	SUV9	E11	118500	CH	X	2.1,5,6	15						
	10-12	B,E	SUV9	E11	118500	CH	X	2.1,5,6	15						
RL Series	96-01	B	PC3	E5	118336	HG		2.1,5	5						
SLX	96-99	B	SUV5	E5	118339	BN,HG		2.1,5	5						
TL	04-08	B,LD	PC3,4	E10	118489	HG		2.1,7,5	10						
TL Series	96-03	B	PC3	E5	118336	HG		2.1,5	5						
TSX	06-12	B	PC3	E11	118302	HG		2.1,4,2	10						
ZDX	10-12	B,E	SUV9	E13	118503	CH	X	2.1,5,6	30						
BUICK															
Enclave	08-12	A,N	SUV1,2	E7	118450	BN		7.5	10						
	w/Factory 7-Way	08-12	A,N	SUV6						E8	118015 20047 20119 118384	RD RD RD BN,RD	7-Way 7-Way Both 4-Flat		7.5 10 10 5
La Crosse	05-09	A	PC1,2	E7	118479			7.5	10						
	All Models	10-12	BP,LD	PC1,2	E18	118497	CH	X	2.1,5,6	45					
Lucerne	All Models	06-09	A	PC3,4	E5	118419		7.5	10						
	All Models	10-11	A	PC3,4	E5	118419		7.5	10						
Rainier	w/Factory 7-Way	04-07	H	SUV6						E8	118384 20119 20047 118015	BN,RD RD RD RD	4-Flat Both 7-Way 7-Way	7.5	5 10 10 10
Regal	All Models	11-12	A,E	PC1,2	E18	118504	CH	X	2.1,5,6	45					
Rendezvous		02-07	A	SUV1,2	E10	118383	BN		7.5	20					
Roadmaster		91-96	A	PC3,4	E3	118347		7.5	10						
Roadmaster Estate Wagon		91-96	A	PC3,4	E4	118352		7.5	10						
Terraza		05-07	A	SUV1,2	E10	118396	BN		7.5	15					
CADILLAC															
CTS	03-07	B,E	PC3	E15	118440	CH	X	2.1,4,2	45						
	4 Dr. Sedan Only	08-12	SK	PC3,4	E15	118466	CH	X	2.1,5,6	15					
CTS-V	04-07	B,E	PC3	E15	118440	CH	X	2.1,4,2	45						
DTS	06-11	B,E	PC3,4	E16	118535	CH	X	2.1,5,6	45						
Escalade	Old Body Style	99-00	A	SUV7	E3	118319	BN		7.5	5					
		02-11	H	SUV6	E8	118384	BN,RD		7.5	5					
	w/Factory 7-Way	02-11	H	SUV6							E8	118015 20047 20119	RD RD RD	7-Way 7-Way Both	
Escalade ESV	w/Factory 7-Way	03-11	H	SUV6	E8	118384	BN,RD		7.5	5					
		03-11	H	SUV6							E8	20119 20047 118015	RD RD RD	Both 7-Way 7-Way	
Escalade EXT	w/Factory 7-Way	02-11	H	SUV6	E8	118384		7.5	5						
SRX	w/Factory Tow Package	10-12	E,LD	SUV5						E3	118259	BN	4-Flat	7.5	5
CHEVROLET															
Avalanche	w/Factory 7-Way	02-11	H	SUV6	E8	118384		7.5	5						
Aveo	4 Dr. Sedan	04-06	B	PC3,4	E13	118485	CG	X	2.1,7,5	15					
	5 Dr. Hatchback	04-11	B	PC3,4	E13	118485	CG	X	2.1,7,5	15					
Blazer	Full Size	73-84	A	SUV1,2	E1	118311	BN		7.5	5					
		85-91	A	SUV1,2	E3	118312	BN		7.5	5					
		92-94	A	SUV6	E3	118319	BN		7.5	5					
	Downsize w/Factory 7-Way	99-01	A	SUV6							E8	118015 20047 20119 118384	RD RD RD BN,RD	7-Way 7-Way Both 4-Flat	
Camaro	All Models	10-11	A,F	PC1,2	E17	118486	CH	X	2.1,5,6	15					
Caprice		91-96	A	PC3,4	E3	118347		7.5	10						



MAKE/MODEL	YEAR	ELEC	POS	T-ONE (4-Flat)						OEM Replacement						
				PC	Part No.	FN	CP	Amp	IN	PC	Part No.	FN	TYPE	CP	Amp	IN
CHEVROLET (Continued)																
Caprice Estate Wagon	91-96	A	PC3,4	E4	118352			7.5	10							
Cobalt	2 Dr. Only	05-11	A	PC1,2	E5	118407	BN		7.5	15						
	4 Dr. Only	05-11	A	PC1,2	E8	118398	BN		7.5	10						
Cobalt Sport	2 Dr. Only	08-11	A	PC1,2	E5	118407	BN		7.5	15						
	4 Dr. Only	08-11	A	PC1,2	E8	118398	BN		7.5	10						
Cobalt SS	2 Dr. Only	05-11	A	PC1,2	E5	118407	BN		7.5	15						
	4 Dr. Only	05-11	A	PC1,2	E8	118398	BN		7.5	10						
Colorado	All Models	04-12	B	PU3	E9	118301	BN,CG	X	2.1,5	10						
	w/Factory 7-Way	04-12	H	PU3							E8	118384 20119 20047 118015	BN,RD RD RD RD	4-Flat Both 7-Way 7-Way		7.5 10 10 10
Cruze	All Models	11-12	B,E	PC3,4	E19	118508	CH	X	2.1,5,6	45						
Equinox		05-06	B	SUV3	E8	118391	CG	X	2.1,5	10						
		07-09	A	SUV3	E7	118432	CE		7.5	10						
	All Models w/Factory Tow Package	10-12 10-12	N,E N,A	SUV3,4 SUV3	E16	118494	CH	X	2.1,5,6	45	EI	118264	RD			7.5 15
Express Van	Full Size	96-99	B	SUV3,4	E8	118335	HG		2.1,5	20						
	w/Factory Tow Package	96-99	B	SUV3,4							EI	118240		4-Flat		7.5 5
	Full Size	00-02	B	SUV3,4	E8	118377	HG		2.1,5	10						
	w/Factory Tow Package	00-02	B	SUV3,4							EI	118240		4-Flat		7.5 5
	w/Factory Tow Package Full Size	03 03-11	A A	SUV3,4 SUV3,4	E5	118392			7.5	20	EI	118240		4-Flat		7.5 5
HHR		06-11	A	SUV3,4	E5	118407	BN		7.5	15						
HHR SS		08-11	A	SUV3,4	E5	118407	BN		7.5	15						
Impala	All Models	00-05	A	PC3,4	E5	118512			7.5	25						
	All Models	06-12	A	PC2	E5	118417	BN		7.5	10						
Impala SS		94-96	A	PC3,4	E3	118347			7.5	10						
Lumina APV Van		93	A,F	SUV1,2	E7	118337			7.5	20						
		94-96	A	SUV1,2	E7	118337			7.5	20						
Malibu	4 Dr. Sedan Only	04-07	A	PC3,4	E7	118439	BN		7.5	15						
	SS 4 Dr. Sedan Only	06-07	A	PC3,4	E7	118439	BN		7.5	15						
	All, Except LTZ	08-12	A	PC1,2	E7	118450	BN		7.5	10						
Malibu Classic	4 Dr. Sedan Only (Old Body Style)	08	A	PC3,4	E7	118439	BN		7.5	15						
	SS 4 Dr. Sedan Only (Old Body Style)	08	A	PC3,4	E7	118439	BN		7.5	15						
Malibu Maxx		04-05	A	PC3,4	E7	118439	BN		7.5	15						
	All, Except SS	06-07	A	PC3,4	E7	118439	BN		7.5	15						
Pickup, C/K Series		73-84	A	PU3	E1	118311	BN		7.5	5						
		85-87	A	PU3	E3	118312	BN		7.5	5						
	Crew Cab (Old Body Style)	88-91	A	PU3	E3	118312	BN		7.5	5						
	All, Except 88-91 Crew Cab	88-00	A	PU3	E3	118315	BN		7.5	5						
Pickup, Silverado	w/Factory 7-Way	99-06	H	PU3												
											E8	20119 118015 20047 118384	RD RD RD BN,RD	Both 7-Way 7-Way 4-Flat		7.5 10 10 10
	Classic w/Factory 7-Way	07	H	PU3								20119 118015 20047	RD RD RD	Both 7-Way 7-Way		7.5 10 10
												118384 118015 20047	BN,RD RD RD	4-Flat 7-Way 7-Way		7.5 10 10
	New Body Style w/Factory 7-Way	07-11	A	PU3								118384 20047	BN,RD RD	4-Flat 7-Way		7.5 10
	New Body Style New Body Style w/Factory 7-Way	07-12 07-12	A A	PU3 PU3	E8	118384	BN,RD		7.5	5		118015 20119	RD RD	7-Way Both		10 10
S-10 Blazer	Downsize, 2 Dr.	84-91	A	SUV6	E3	118318	BN		7.5	20						
S-10 Pickup		85-97	A	PU3	E3	118312	BN		7.5	5						
		98-04	A	PU3	E4	118359	BN		7.5	5						
Suburban		73-84	A	SUV5	E1	118311	BN		7.5	5						
		85-91	A	SUV5	E3	118312	BN		7.5	5						
	Old Body Style	92-99	A	SUV6	E3	118319	BN		7.5	5						
	New Body Style w/Amber Turn Signals New Body Style w/Amber Turn Signals w/Factory 7-Way	00-11 00-11	H H	SUV6 SUV6	E8	118384	BN,RD		7.5	5		20047 118015 20119	RD RD RD	7-Way 7-Way Both		10 10 10



MAKE/MODEL	YEAR	ELEC	POS	T-ONE (4-Flat)						OEM Replacement					
				PC	Part No.	FN	CP	Amp	IN	PC	Part No.	FN	TYPE	CP	Amp
CHEVROLET (Continued)															
Tahoe	Old Body Style	95-00	A	SUV6	E3	118319	BN		7.5	5					
	New Body Style w/Amber Turn Signals	00-11	H	SUV6	E8	118384	BN,RD		7.5	5					
	New Body Style w/Amber Turn Signals w/Factory 7-Way	00-11	H	SUV6								20119	RD	Both	10
											118015	RD	7-Way	10	
											20047	RD	7-Way	10	
Tracker		98	B	SUV3	E5	118372	HG		2.1,5	5					
		99-04	B	SUV3	E5	118372	HG		2.1,5	5					
TrailBlazer	w/Factory 7-Way	99-01	A	SUV6											
											20047	RD	7-Way	10	
											118015	RD	7-Way	10	
											20119	RD	Both	10	
											E8 118384	BN,RD	4-Flat	7.5 5	
											E8 118384	BN,RD	4-Flat	7.5 5	
											20119	RD	Both	10	
											118015	RD	7-Way	10	
											20047	RD	7-Way	10	
Traverse		09-12	A,N	SUV1,2	E7	118450	BN		7.5	10					
	w/Factory 7-Way	09-12	A,N	SUV6											
											E8 20047	RD	7-Way	10	
											118015	RD	7-Way	10	
											20119	RD	Both	10	
											E8 118384	BN,RD	4-Flat	7.5 5	
Uplander	All, Inc. AWD	05-08	A	SUV1,2	E10	118396	BN		7.5	15					
	All, Inc. AWD (Canada Only)	09	A	SUV1,2	E10	118396	BN		7.5	15					
Van, G-Series	Full Size	87-95	A	SUV1,2	E4	118338			7.5	10					
Venture		97-05	B	SUV3	E8	118355	HG		2.1,5	10					
CHRYSLER															
200	4 Dr. Sedan	11-12	B,E	PC1,2	E18	118550	BN,CH	X	2.1,5,6	45					
200 Convertible		11	B,E	PC1,2	E18	118550	BN,CH	X	2.1,5,6	45					
300	All, Except 300C	05-07	A	PC3,4	E7	118404			7.5	10					
		08-10	B,E	PC3,4	E14	118406	CH	X	2.1,5,6	15					
		11	B,E	PC3,4	E16	118544	CH	X	2.1,5,6	25					
300C		05-10	B,E	PC3,4	E14	118406	CH	X	2.1,5,6	15					
		11	B,E	PC3,4	E16	118544	CH	X	2.1,5,6	25					
300M		99-04	B	PC1,2	E12	118364	BN,HG		2.1,5	15					
Aspen	w/Factory 7-Way	07-08	H	SUV6							E3 118381	BN,RD	4-Flat	7.5 5	
											20135	RD	Both	10	
	w/Factory 7-Way	07-09	B,E	SUV1,2	E15	118390	BN,CH	X	2.1,5,6	45					
		09	H	SUV6							E8 20119	RD	Both	10	
											118015	RD	7-Way	10	
											E8 118384	BN,RD	4-Flat	7.5 5	
Concorde		98-02	B	PC1,2	E12	118364	BN,HG		2.1,5	15					
Intrepid	Canada Only	98-04	B	PC1,2	E12	118364	BN,HG		2.1,5	15					
LHS		99	B	PC3,4	E12	118364	BN,HG		2.1,5	15					
Pacifica		04-08	B,F	SUV1,2	E17	118303	BN,CH	X	2.1,5,6	25					
	w/Factory 7-Way	04-08	H	SUV6							E3 118381	BN,RD	4-Flat	7.5 5	
											20135	RD	Both	10	
PT Cruiser		01-04	B	SUV1,2	E19	118462	BN,CH	X	2.1,4,2	45					
	All, Inc. GT & Turbo Models	05-10	B,E	SUV1,2	E19	118462	BN,CH	X	2.1,4,2	45					
PT Cruiser Convertible		05-10	B,E	SUV1,2	E19	118462	BN,CH	X	2.1,4,2	45					
Sebring	All, Inc. GT & Turbo Models	07-10	B,E	PC1,2	E19	118444	BN,CH	X	2.1,4,2	45					
Sebring Convertible		07-10	B,E	PC1,2	E19	118444	BN,CH	X	2.1,4,2	45					
Town & Country	Mini Van	91-95	A	SUV1,2	E16	118323	BN		7.5	10					
		96-00	B	SUV1,2	E10	118334	HG		2.1,5	20					
		01-03	B	SUV1,2	E7	118376	HG		2.1,5	15					
		04-07	A	SUV1,2	E7	118300			7.5	20					
		08-10	A,E	SUV1,2	E18	118552	CH	X	4,2,7,5	45					
					E16	118446	†,CH	X	2.1,4,2	45					
					E18	118534	BN,CH	X	4,2,7,5	45					
		11-12	A,E	SUV1,2	E7	118376	HG		2.1,5	15					
Voyager		01-03	B	SUV1,2	E7	118376	HG		2.1,5	15					
DODGE															
Avenger		08-10	A,E	PC1,2	E19	118445	BN,CH	X	2.1,4,2	45					
		11-12	B,E	PC1,2	E18	118550	BN,CH	X	2.1,5,6	45					



MAKE/MODEL	YEAR	ELEC	POS	T-ONE (4-Flat)					OEM Replacement								
				PC	Part No.	FN	CP	Amp	IN	PC	Part No.	FN	TYPE	CP	Amp	IN	
DODGE (Continued)																	
Caliber	All Models	07	B,E	PC1,2	E18	118428	BN,CH	X	2.1,4.2	45							
	All Models	08-11	A,E	PC1,2	E18	118552	CH	X	4.2,7.5	45							
					E16	118446	†,CH	X	2.1,4.2	45							
Caravan		91-95	A	SUV1,2	E16	118323	BN		7.5	10							
		96-00	B	SUV1,2	E10	118334	HG		2.1,5	20							
		01-03	B	SUV1,2	E7	118376	HG		2.1,5	15							
		04-07	A	SUV1,2	E7	118300			7.5	20							
Challenger	All Models	08-12	A	PC3,4	E7	118404			7.5	10							
Charger	All Models	06-10	A	PC3,4	E7	118404			7.5	10							
	All Models	11-12	B,E	PC3,4	E18	118542	CH	X	4.2,7.5	25							
Dakota Pickup		87-94	A	PU3,4	E4	118317	BN		7.5	5							
		95-03	A	PU3,4	E7	118329	BN,HJ		7.5	5							
	w/Factory 7-Way	00-09	A	PU3							E3	20135 118381	RD BN,RD	Both 4-Flat		7.5	10 5
Durango		03-11	A	PU1,2	E16	118323	BN		7.5	10							
		98-03	B	SUV1,2	E10	118334	BN,HG		2.1,5	20							
	w/Factory 7-Way	00-08	H	SUV6							E3	118381 20135	BN,RD RD	4-Flat Both		7.5	5 10
		04-09	B,E	SUV1,2	E15	118390	BN,CH	X	2.1,5.6	45							
	w/Factory 7-Way	09	H	SUV6							E8	20119 118015 118384	RD RD BN,RD	Both 7-Way 4-Flat		7.5	10 10 5
Grand Caravan		11-12	A,E	SUV1,2	E16	118446	†,CH	X	2.1,4.2	45							
					E18	118552	CH	X	4.2,7.5	45							
		91-95	A	SUV1,2	E16	118323	BN		7.5	10							
		96-00	B	SUV1,2	E10	118334	HG		2.1,5	20							
		01-03	B	SUV1,2	E7	118376	HG		2.1,5	15							
		04-07	A	SUV1,2	E7	118300			7.5	20							
Intrepid		08-10	A,E	SUV1,2	E16	118446	†,CH	X	2.1,4.2	45							
					E18	118552	CH	X	4.2,7.5	45							
		11-12	A,E	SUV1,2	E18	118534	BN,CH	X	4.2,7.5	45							
Journey		98-04	B	PC1,2	E12	118364	BN,HG		2.1,5	15							
Journey		09	B,F	SUV1,2	E18	118474	CH	X	2.1,5.6	45							
		10	A	SUV1,2	E8	118495			7.5	10							
Magnum	All Models	05-08	B,E	PC1,2	E19	118402	BN,CH	X	2.1,5.6	45							
Nitro		07	B	SUV1,2	E19	118455	BN,CH	X	2.1,5.6	30							
					E13	118421	CG	X	2.1,5	15							
		08-11	B,E	SUV1,2	E19	118455	CH	X	2.1,5.6	30							
Pickup, D/W Series, Full Size		86-93	A	PU1,2	E4	118317	BN,HJ		7.5	5							
	350 Cab & Chassis	87-93	A	PU3,4	E4	118317	BN		7.5	5							
Pickup, Ram, Full Size		94	A	PU1,2	E4	118317	BN,HJ		7.5	5							
	3500 Cab & Chassis	94-02	A	PU3,4	E4	118317	BN		7.5	5							
		95-01	A	PU3,4	E7	118329	BN,HJ		7.5	5							
	1500 Only w/Factory 7-Way	00-08	H	PU3							E3	118381 20135	BN,RD RD	4-Flat Both		7.5	5 10
	2500 HD Only w/Factory 7-Way	00-09	H	PU3							E3	118381 20135	BN,RD RD	4-Flat Both		7.5	5 10
	3500 HD Only w/Factory 7-Way	00-09	H	PU3							E3	118381 20135	BN,RD RD	4-Flat Both		7.5	5 10
	2500 Only, All Models	02	A	PU3,4	E7	118329	BN,HJ		7.5	5							
	3500 Only, All Models	02	A	PU3,4	E7	118329	BN,HJ		7.5	5							
	1500 Only w/Factory 7-Way	09-12	A	PU3							E8	20119 118384 118015	RD BN,RD RD	Both 4-Flat 7-Way		7.5	10 5 10
	2500 HD Only w/Factory 7-Way	10-11	A	PU3							E8	20119 118015 118384	RD RD BN,RD	Both 7-Way 4-Flat		7.5	10 10 5
	3500 HD Only w/Factory 7-Way	10-11	A	PU3							E8	20119 118015 118384	RD RD BN,RD	Both 7-Way 4-Flat		7.5	10 10 5
Ramcharger		86-93	A	SUV5,7	E4	118317	BN		7.5	5							



MAKE/MODEL	YEAR	ELEC	POS	T-ONE (4-Flat)						OEM Replacement								
				PC	Part No.	FN	CP	Amp	IN	PC	Part No.	FN	TYPE	CP	Amp	IN		
DODGE (Continued)																		
Sprinter	w/Factory 7-Way	03-06	H	SUV6								E3	118381	BN,RD	4-Flat		7.5	5
	w/Factory 7-Way	07-09	H	SUV6									20135	RD	Both			10
												E3	118381	BN,RD	4-Flat		7.5	5
Van, B-Series	Full Size	93-98	A	SUV5	E1	118328	BN		7.5	5								
Van, Ram	Full Size	99-00	A	SUV5	E1	118368	BN		7.5	5								
	Full Size	01-03	A	SUV5	E3	118381	BN,RD		7.5	5								
	w/Factory 7-Way	01-03	A	SUV5									20135	RD	Both			10
FIAT																		
500	All, Inc. 500c (Cabrio)	12	B,E	PC1,2	E20	118546	BN,CH	X	4,2,7,5	45								
FORD																		
Aerostar Van	Extended Body	97	A	SUV1,2	E4	118344	BN		7.5	10								
	Standard Body	97	A	SUV1,2	E4	118344	BN		7.5	10								
Bronco	Full Size	80-86	A	SUV6	E1	118313	BN		7.5	5								
	Full Size	92-96	A	SUV6	E5	118350	BN		7.5	5								
E-150 Econoline Van	Full Size, All Models	92-94	B	SUV1,2	E8	118343	HG		2,1,5	10								
	Full Size, All Models	95-03	A	SUV1,2	E15	118345	BN,GC		2,1,4,2	45								
	Full Size, All Models w/Factory 7-Way	97-09	A	SUV6	E4	118344	BN		7.5	10			20119	RD	Both			10
	Full Size, All Models	08-12	A,RW	SUV1,2	E17	118551	CH	X	4,2,7,5	45			118015	RD	7-Way			10
	Full Size, All Models w/Factory 4-Flat (Prepped Class I Towing Package)	09-12	A	SUV6							E3	118260	BN	4-Flat		7.5	10	
	Full Size, All Models w/Factory 7-Way (Prepped Class II Towing Package)	09-12	A	SUV6							E14	118261	BN	7-Way			10	
E-250 Econoline Van	Full Size, All Models	92-94	B	SUV1,2	E15	118345	BN,GC		2,1,4,2	45								
	Full Size, All Models	95-03	A	SUV1,2	E8	118343	HG		2,1,5	10								
	Full Size, All Models w/Factory 7-Way	97-09	A	SUV6	E4	118344	BN		7.5	10			20119	RD	Both			10
	Full Size, All Models	08-12	A,RW	SUV1,2	E17	118551	CH	X	4,2,7,5	45			118015	RD	7-Way			10
	Full Size, All Models w/Factory 4-Flat (Prepped Class I Towing Package)	09-12	A	SUV6							E3	118260	BN	4-Flat		7.5	10	
	Full Size, All Models w/Factory 7-Way (Prepped Class II Towing Package)	09-12	A	SUV6							E14	118261	BN	7-Way			10	
E-350 Econoline Van	Full Size, All Models	92-94	B	SUV1,2	E15	118345	BN,GC		2,1,4,2	45								
	Full Size, All Models	95-03	A	SUV1,2	E8	118343	HG		2,1,5	10								
	Full Size, All Models w/Factory 7-Way	97-09	A	SUV6	E4	118344	BN		7.5	10			20119	RD	Both			10
	Full Size, All Models	08-12	A,RW	SUV1,2	E17	118551	CH	X	4,2,7,5	45			118015	RD	7-Way			10
	Full Size, All Models w/Factory 4-Flat (Prepped Class I Towing Package)	09-12	A	SUV6							E3	118260	BN	4-Flat		7.5	10	
	Full Size, All Models w/Factory 7-Way (Prepped Class II Towing Package)	09-12	A	SUV6							E14	118261	BN	7-Way			10	
Edge	All, Inc. Sport Models	07-10	E,N	SUV1,2	E17	118551	CH	X	4,2,7,5	45								
	All, Inc. Sport Models	11-12	E,N	SUV1,2	E21	118515	CH	X	4,2,7,5	45								
Escape		00-03	B	SUV1,2	E8	118343	HG,RW		2,1,5	10								
					E15	118345	BN,GC,RW		2,1,4,2	45								
	All, Inc. Hybrid	05-07	B,E	SUV1,2	E17	118426	BN,CH	X	2,1,4,2	45								
	All, Inc. Hybrid & Vehicles w/Backup Sensors	08-12	A	SUV1,2	E17	118551	CH	X	4,2,7,5	45								
	All, Inc. Hybrid & Vehicles w/o Backup Sensors	08-12	A	SUV5							E1	118251	BN,QP	4-Flat		7.5	5	
Escort	4 Dr. Sedan	97-99	A	PC1,2	E4	118344			7.5	10								
	ZX2	98-03	A	PC1,2	E4	118344			7.5	10								
Excursion		00-03	A	SUV1,2	E4	118344	BN		7.5	10								
	w/Factory 7-Way	00-03	A	SUV6									20119	RD	Both			10
	w/Factory 7-Way	04-05	A	SUV6									118015	RD	7-Way			10
			A	SUV6									118015	RD	7-Way			10



MAKE/MODEL	YEAR	ELEC	POS	T-ONE (4-Flat)						OEM Replacement						
				PC	Part No.	FN	CP	Amp	IN	PC	Part No.	FN	TYPE	CP	Amp	IN
FORD (Continued)																
Expedition	97-03	A	SUV1,2	E4	118344	BN		7.5	10							
w/Factory 7-Way	97-03	A	SUV6								118015	RD	7-Way			10
											20119	RD	Both			10
w/Factory 7-Way	04-11	A	SUV6								20119	RD	Both			10
											118015	RD	7-Way			10
Explorer	91-94	A	SUV1	E3	118324	BN		7.5	20							
	95-00	B,E	SUV1,2	E15	118345	BN,GC		2.1,4.2	45							
w/Factory Tow Package	95-01	A	SUV7							E1	118241	BN	4-Flat		7.5	5
4 Dr. w/Factory 7-Way	00-01	A	SUV6								20119	RD	Both			10
											118015	RD	7-Way			10
2 Dr. Sport w/Factory 7-Way	00-03	A	SUV6								118015	RD	7-Way			10
											20119	RD	Both			10
4 Dr.	01	B,E	SUV1,2	E15	118345	BN,GC		2.1,4.2	45							
2 Dr. Sport	01-03	A	SUV1,2	E4	118344	BN		7.5	10							
4 Dr.	02-03	A	SUV1,2	E4	118344	BN		7.5	10							
4 Dr. w/Factory 7-Way	02-03	A	SUV6								118015	RD	7-Way			10
											20119	RD	Both			10
4 Dr. w/Factory 7-Way	04-10	A	SUV6								20119	RD	Both			10
											118015	RD	7-Way			10
	11-12	A	SUV7	E11	118540	BN		7.5	5							
w/Factory 7-Way	11-12	A	SUV6								118015	RD	7-Way			10
											20119	RD	Both			10
Explorer Sport Trac	02-03	A	SUV1,2	E4	118344	BN		7.5	10							
w/Factory 7-Way	07-10	A	SUV6								20119	RD	Both			10
											118015	RD	7-Way			10
F-100, F-150, F-250, F-350	80-86	A	PU3	E1	118313	BN		7.5	5							
	87-96	A	PU3	E3	118316	BN		7.5	5							
F-150	97-03	A	PU1,2	E4	118344	BN		7.5	10							
Flareside	04	A	PU3							E19	118247	BN	7-Way			5
(New Body Style) w/Factory 4-Flat	04	A	PU3								118015	RD	7-Way			10
Flareside (New Body Style) w/Factory 7-Way	04-11	A	PU3								20119	RD	Both			10
											118015	RD	7-Way			10
Styleside (New Body Style) w/Factory 7-Way	04-11	A	PU3								20119	RD	Both			10
F-150 Light Duty																
Flareside w/Factory 4-Flat	97-03	A	PU1,2							E19	20128	1	6-Way			5
											20130	2	7-Way			5
Flareside w/Factory 7-Way	97-03	A	PU3								118242	BN	7-Way			5
											20119	RD	Both			10
Styleside w/Factory 4-Flat	97-03	A	PU1,2								118015	RD	7-Way			10
											20128	1	6-Way			5
											20130	2	7-Way			5
Styleside w/Factory 7-Way	97-03	A	PU3							E19	118242	BN	7-Way			5
											20119	RD	Both			10
											118015	RD	7-Way			10
F-150 Light Duty Heritage																
(Old Body Style) Flareside w/Factory 4-Flat	04	A	PU1,2							E19	118242	BN	7-Way			5
(Old Body Style) Styleside w/Factory 4-Flat	04	A	PU1,2							E19	118242	BN	7-Way			5
(Old Body Style) w/Factory 4-Flat	04	A	PU1,2								20130	2	7-Way			5
											20128	1	6-Way			5
(Old Body Style) w/Factory 7-Way	04	A	PU3								118015	RD	7-Way			10
											20119	RD	Both			10
Flareside (Old Body Style)	04	A	PU1,2	E4	118344	BN		7.5	10							
F-150 SuperCrew	00-03	A	PU1,2	E4	118344	BN		7.5	10							
w/Factory 7-Way	00-03	A	PU3								118015	RD	7-Way			10
											20119	RD	Both			10
New Body Style w/Factory 7-Way	04-11	A	PU3								20119	RD	Both			10
											118015	RD	7-Way			10
F-250 Heavy Duty	97	A	PU3	E3	118316	BN		7.5	5							
F-250 Light Duty																
Styleside w/Factory 4-Flat	97-99	A	PU1,2							E19	20128	1	6-Way			5
											20130	2	7-Way			5
											118242	BN	7-Way			5
Styleside w/Factory 7-Way	97-99	A	PU3								20119	RD	Both			10
											118015	RD	7-Way			10



MAKE/MODEL	YEAR	ELEC	POS	T-ONE (4-Flat)						OEM Replacement						
				PC	Part No.	FN	CP	Amp	IN	PC	Part No.	FN	TYPE	CP	Amp	IN
FORD (Continued)																
F-250 Super Duty	w/Factory 4-Flat	99-01	A	PU1,2							E15	20131	2	7-Way		5
												20129	1	6-Way		5
	w/Factory 7-Way	99-01	A	PU3								118243	BN	7-Way		5
											118015	RD	7-Way		10	
	w/Factory 7-Way	02-12	A	PU3							20119	RD	Both		10	
											20119	RD	Both		10	
											118015	RD	7-Way		10	
F-350 Heavy Duty		97	A	PU3	E3	118316	BN		7.5	5						
F-350 Super Duty	w/Factory 4-Flat	99-01	A	PU1,2							E15	118243	BN	7-Way		5
												20129	1	6-Way		5
	w/Factory 7-Way	99-01	A	PU3								20131	2	7-Way		5
											20119	RD	Both		10	
	w/Factory 7-Way	02-12	A	PU3								118015	RD	7-Way		10
											118015	RD	7-Way		10	
											20119	RD	Both		10	
F-450 Super Duty	w/Factory 4-Flat	99-01	A	PU1,2							E15	20129	1	6-Way		5
												20131	2	7-Way		5
	w/Factory 7-Way	99-01	A	PU3								118243	BN	7-Way		5
											20119	RD	Both		10	
	w/Factory 7-Way	02-12	A	PU3								118015	RD	7-Way		10
											118015	RD	7-Way		10	
											20119	RD	Both		10	
F-550 Super Duty	w/Factory 4-Flat	99-01	A	PU1,2							E15	118243	BN	7-Way		5
												20129	1	6-Way		5
	w/Factory 7-Way	99-01	A	PU3								20131	2	7-Way		5
											20119	RD	Both		10	
	w/Factory 7-Way	02-11	A	PU3								118015	RD	7-Way		10
											118015	RD	7-Way		10	
											20119	RD	Both		10	
Fiesta	4 Dr. Sedan	11-12	A,E	PC3,4	E14	118422	CH	X	2.1,4,2	30						
	5 Dr. Hatchback	11-12	W	PC3,4	E18	118471	CH	X	2.1,5,6	45						
Five Hundred		05-07	A	PC3,4	E5	118395			7.5	10						
Flex	All, Inc. EcoBoost	09-12	A	SUV1,2	E8	118472			7.5	15						
	w/Factory 7-Way	09-12	A	SUV6								20119	RD	Both		10
											118015	RD	7-Way		10	
Focus	Coupe	08-11	A	PC1,2	E5	118457	BN		7.5	15						
	Sedan	08-11	A	PC1,2	E5	118457	BN		7.5	15						
	5 Dr. Hatchback, Except ST Model w/Center Exhaust Sedan Only	12	B,E	PC1,2	E18	118549	CH	X	2.1,5,6	45						
		12	B,E	PC3,4	E16	118548	CH	X	2.1,5,6	45						
Focus Wagon	Built Before 11/2002	00-03	A	PC1,2	E4	118344	FW		7.5	10						
Freestar		04-07	E,N	SUV1,2	E17	118385	CH	X	2.1,5,6	45						
Freestyle		05-07	A	SUV3,4	E5	118395			7.5	10						
Fusion		06-09	A,E	PC3,4	E14	118422	CH	X	2.1,4,2	30						
		10-12	A,E	PC3,4	E14	118422	CH	X	2.1,4,2	30						
LTD Crown Victoria		92-97	A,F	PC3,4	E9	118326			7.5	20						
Mustang	All, Except Cobra SVT 99-04	94-04	A	PC3,4	E9	118326			7.5	20						
		10-12	SK	PC3,4	E16	118487	CH	X	2.1,5,6	45						
Ranger Pickup		83-85	A	PU3	E1	118313	BN		7.5	5						
		86-92	A	PU1,2	E3	118314	BN		7.5	5						
		93-99	B	PU3	E7	118325	BN,HG		2.1,5	5						
	w/Factory Tow Package	98-99	A	SUV5							E1	118241	BN	4-Flat	7.5	5
		00-03	A	PU1,2	E4	118344	BN		7.5	10						
	w/Factory 7-Way	00-03	A	PU3								118015	RD	7-Way		10
											20119	RD	Both		10	
	w/Factory 7-Way	04-11	A	PU3							20119	RD	Both		10	
											118015	RD	7-Way		10	
Taurus	Sedan, Inc. SHO	92-95	A	PC3,4	E4	118327			7.5	10						
	Sedan, Inc. SHO	96-99	B	PC3,4	E9	118333	HG		2.1,5	10						
	Sedan, All Models	00-03	A	PC3,4	E4	118375			7.5	10						
	Sedan, All Models	08-09	A	PC3,4	E7	118447			7.5	10						
	Sedan, Inc. SHO	10-12	B	PC3,4	E12	118493	CG	X	2.1,7,5	10						
Taurus X		08-09	A	SUV3,4	E7	118448			7.5	15						
Transit Connect		10-12	B,E	SUV1,2	E24	118254	BN,CH		4-Flat	X	2.1,5,6	45				



MAKE/MODEL	YEAR	ELEC	POS	T-ONE (4-Flat)					OEM Replacement								
				PC	Part No.	FN	CP	Amp	IN	PC	Part No.	FN	TYPE	CP	Amp	IN	
FORD (Continued)																	
Windstar	95-98	B	SUV1,2	E8	118346	HG		2.1,5	20								
	Built Before 11/2002	G,MX	SUV1,2	E19	118366	FW,LS		2.1,4,2	45								
	Built After 11/2002	03	G,MX	SUV1,2	E19	118305	FV,LS	2.1,4,2	45								
FREIGHTLINER																	
Sprinter	w/Factory 7-Way	03-06	H	SUV6						E3	118381	BN,RD	4-Flat		7.5	5	
	w/Factory 7-Way	07-09	H	SUV6							20135	RD	Both			10	
											20135	RD	Both			10	
										E3	118381	BN,RD	4-Flat		7.5	5	
GEO																	
Tracker		96-97	B	SUV3	E5	118372	HG	2.1,5	5								
GMC																	
Acadia		07-12	A,N	SUV1,2	E11	118451	BN	7.5	15								
	w/Factory 7-Way	07-12	A,N	SUV6						E8	118384	BN,RD	4-Flat		7.5	5	
											118015	RD	7-Way			10	
											20119	RD	Both			10	
											20047	RD	7-Way			10	
Canyon	All Models	04-12	B	PU3	E9	118301	BN,CG	X	2.1,5	10							
	w/Factory 7-Way	04-12	H	PU3													
											E8	118015	RD	7-Way		10	
											20119	RD	Both			10	
											118384	BN,RD	4-Flat		7.5	5	
Envoy	w/Factory 7-Way	99-01	A	SUV6						E8	118384	BN,RD	4-Flat		7.5	5	
											20119	RD	Both			10	
											118015	RD	7-Way			10	
											20047	RD	7-Way			10	
	w/Factory 7-Way	02-10	H	SUV6							20119	RD	Both			10	
											118015	RD	7-Way			10	
										E8	118384	BN,RD	4-Flat		7.5	5	
											20047	RD	7-Way			10	
Jimmy	Full Size	73-84	A	SUV1,2	E1	118311	BN	7.5	5								
	Full Size	85-91	A	SUV1,2	E3	118312	BN	7.5	5								
	Downsize w/Factory 7-Way	99-01	A	SUV6							E8	118384	BN,RD	4-Flat		7.5	5
											118015	RD	7-Way			10	
											20047	RD	7-Way			10	
											20119	RD	Both			10	
Pickup, C/K Series		73-84	A	PU3	E1	118311	BN	7.5	5								
		85-87	A	PU3	E3	118312	BN	7.5	5								
	Crew Cab (Old Body Style)	88-91	A	PU3	E3	118312	BN	7.5	5								
	All, Except 88-91 Crew Cab	88-00	A	PU3	E3	118315	BN	7.5	5								
Pickup, Sierra	w/Factory 7-Way	99-06	H	PU3													
											E8	118015	RD	7-Way		10	
											20047	RD	7-Way			10	
											20119	RD	Both			10	
											118384	BN,RD	4-Flat		7.5	5	
											20119	RD	Both			10	
											20047	RD	7-Way			10	
											118015	RD	7-Way			10	
											E8	118384	BN,RD	4-Flat		7.5	5
											20047	RD	7-Way			10	
	New Body Style w/Factory 7-Way	07-11	A	PU3													
	New Body Style	07-12	A	PU3	E8	118384	BN,RD	7.5	5								
	New Body Style w/Factory 7-Way	07-12	A	PU3													
S-15 & Sonoma Pickup		85-97	A	PU3	E3	118312	BN	7.5	5								
		98-04	A	PU3	E4	118359	BN	7.5	5								
S-15 Jimmy	Downsize, 2 Dr.	84-91	A	SUV6	E3	118318	BN	7.5	20								
Savana Van	Full Size	96-99	B	SUV3,4	E8	118335	HG	2.1,5	20								
	w/Factory Tow Package	96-99	B	SUV3,4							E1	118240		4-Flat		7.5	5
	Full Size	00-02	B	SUV3,4	E8	118377	HG	2.1,5	10								
	w/Factory Tow Package	00-02	B	SUV3,4							E1	118240		4-Flat		7.5	5
	w/Factory Tow Package	03	A	SUV3,4							E1	118240		4-Flat		7.5	5
	Full Size	03-12	A	SUV3,4	E5	118392		7.5	20								
Suburban		73-84	A	SUV5	E1	118311	BN	7.5	5								
		85-91	A	SUV5	E3	118312	BN	7.5	5								
		92-99	A	SUV6	E3	118319	BN	7.5	5								
Syclone		91-92	A	PU3	E3	118312	BN	7.5	5								



MAKE/MODEL	YEAR	ELEC	POS	T-ONE (4-Flat)							OEM Replacement					
				PC	Part No.	FN	CP	Amp	IN	PC	Part No.	FN	TYPE	CP	Amp	IN
GMC (Continued)																
Terrain	All Models	10-12	N,E	SUV3,4	E16	118494	CH	X	2.1,5,6	45						
	w/Factory Tow Package	10-12	N,A	SUV3							E1	118264	RD			7.5 15
Van, G-Series	Full Size	87-95	A	SUV1,2	E4	118338			7.5	10						
Yukon	Old Body Style	92-00	A	SUV6	E3	118319	BN		7.5	5						
	New Body Style w/Amber Turn Signals	00-11	H	SUV6	E8	118384	BN,RD		7.5	5						
	New Body Style w/Amber Turn Signals w/Factory 7-Way	00-11	H	SUV6								20119 20047 118015	RD RD RD	Both 7-Way 7-Way		10 10 10
Yukon Denali	Old Body Style	99-00	A	SUV7	E3	118319	BN		7.5	5						
	New Body Style w/Amber Turn Signals	01-11	H	SUV6	E8	118384	BN,RD		7.5	5						
	New Body Style w/Amber Turn Signals w/Factory 7-Way	01-11	H	SUV6								118015 20047 20119	RD RD RD	7-Way 7-Way Both		10 10 10
Yukon XL		00-11	H	SUV6	E8	118384	BN,RD		7.5	5						
	w/Factory 7-Way	00-11	H	SUV6								20047 118015 20119	RD RD RD	7-Way 7-Way Both		10 10 10
Yukon XL Denali		01-11	H	SUV6	E8	118384	BN,RD		7.5	5						
	w/Factory 7-Way	01-11	H	SUV6								20119 118015 20047	RD RD RD	Both 7-Way 7-Way		10 10 10
HONDA																
Accord	Sedan	94-02	B	PC3	E5	118336	HG		2.1,5	5						
	2 Dr.	03-05	B	PC3	E11	118441	CG	X	2.1,5	10						
	4 Dr.	03-05	B	PC3	E11	118302	HG		2.1,4,2	10						
	2 Dr.	06-07	N	PC3	E8	118436	HG		2.1,4,2	10						
	4 Dr.	06-07	B,LD	PC3	E11	118302	HG		2.1,4,2	10						
	4 Dr.	08-11	B,F	PC3,4	E14	118420	CG	X	2.1,5	15						
	2 Dr.	08-12	B	PC3,4	E14	118420	CG	X	2.1,5	15						
Accord Crosstour	All Models	10-12	B,E	SUV3	E11	118500	CH	X	2.1,5,6	15						
Civic	2 Dr., Except Si Models	06-12	B	PC3,4	E12	118437	CG	X	2.1,5	10						
	4 Dr., Except Hybrid & Si Models	06-12	B	PC3,4	E14	118420	CG	X	2.1,5	15						
Civic Del Sol		93-97	B	PC3	E5	118336	HG		2.1,5	5						
CR-V		97-06	B	SUV3	E5	118336	HG		2.1,5	10						
		07-11	B	SUV3	E8	118427	CG	X	2.1,5	45						
CR-Z		11	B,E	PC3,4	E17	118533	CH	X	2.1,5,6	45						
Element		03-04	B	SUV3	E5	118336	HG		2.1,5	10						
		07-11	B,E	SUV3,4	E14	118465	CH	X	2.1,5,6	45						
Fit		07-11	B	PC3,4	E14	118420	CG	X	2.1,5	15						
Odyssey		95-04	B	SUV3	E5	118336	HG		2.1,5	10						
		05-10	B	SUV4	E12	118438	CH	X	2.1,4,2	20						
		11-12	B,E	SUV4	E17	118521	CH	X	4.2,7,5	30						
Passport		94-97	B	SUV1,2	E5	118331	BN,HG		2.1,5	5						
		98-02	B	SUV1,2	E17	118360	BN,HG		2.1,5	15						
Pilot		03-08	B	SUV3	E5	118336	HG		2.1,5	10						
		09-11	B	SUV3,6	E15	118491	CH	X	4.2,7,5	20	E22	118253	BN,CH	7-Way	X	4.2,7.5 20
Prelude		01-02	B	PC3	E5	118336	HG		2.1,5	5						
Ridgeline		06-11	B	PU1,2	E15	118400	BN,CG	X	2.1,5	10						
HUMMER																
H2	w/Factory 7-Way	03-09	H	SUV6								E8	118384	BN,RD	4-Flat	7.5 5
													20047	RD	7-Way	
													118015	RD	7-Way	
													20119	RD	Both	
H2 SUT	w/Factory 7-Way	05-09	H	SUV6								E8	20119	RD	Both	7.5 5
													118015	RD	7-Way	
													20047	RD	7-Way	
													118384	BN,RD	4-Flat	
H3	w/Factory 7-Way	06-10	A	SUV6								E8	118384	BN,RD	4-Flat	7.5 5
													20047	RD	7-Way	
													118015	RD	7-Way	
													20119	RD	Both	



MAKE/MODEL	YEAR	ELEC	POS	T-ONE (4-Flat)						OEM Replacement							
				PC	Part No.	FN	CP	Amp	IN	PC	Part No.	FN	TYPE	CP	Amp	IN	
JEEP (Continued)																	
Grand Cherokee (Continued)	11-12	A	SUV1,2	E7	118425	BN		7.5	20								
w/Factory 7-Way	11-12	H	SUV6							E8	20119 118015 118384	RD RD BN,RD	Both 7-Way 4-Flat		10 10 5		
Grand Wagoneer	93	B,E	SUV3,4	E16	118348	GC		2.1,4.2	45								
Liberty	02-07	B,F	SUV1,2	E20	118524	CH	X	4.2,7.5	45								
w/Factory 7-Way	05-08	H	SUV6							E3	118381 20135	BN,RD RD	4-Flat Both		7.5 5 10		
	08-12	B,E	SUV1,2	E19	118455	CH	X	2.1,5.6	30								
w/Factory 7-Way	09-12	H	SUV6							E8	20119 118015 118384	RD RD BN,RD	Both 7-Way 4-Flat		10 10 5		
Patriot	07	B,F	SUV1,2	E18	118428	BN,CH	X	2.1,4.2	45								
	08-11	A,F	SUV1,2	E18	118552	CH	X	4.2,7.5	45								
				E16	118446	†,CH	X	2.1,4.2	45								
TJ	Canada	97	A	SUV5,7	E5	118356	BN		7.5	10							
	Canada	98-04	A	SUV5,7	E7	118409	BN		7.5	15							
	Canada	05-06	A	SUV5,7	E7	118409	BN		7.5	15							
Wrangler		91-95	A	SUV5,7	E5	118356	BN		7.5	10							
		97	A	SUV5,7	E5	118356	BN		7.5	10							
	All, Inc. Unlimited	98-04	A	SUV5,7	E7	118409	BN		7.5	15							
	All, Inc. Unlimited	05-06	A	SUV5,7	E7	118409	BN		7.5	15							
	All Models	07-12	A	SUV1	E5	118416	BN		7.5	10							
YJ	Canada	91-95	A	SUV5,7	E5	118356	BN		7.5	10							
KIA																	
Amanti		07-09	B	PC3,4	E10	118453	HG		2.1,7.5	10							
Borrego	w/Factory 7-Way	09-11	H	SUV6							E8	118384 118015 20119	BN,RD RD RD	4-Flat 7-Way Both		7.5 10 10	
Forte	4 Dr. Sedan, All Models	10-12	B	PC3,4	E12	118415	CG	X	2.1,5	20							
Optima		07-08	A	PC3,4	E7	118452			7.5	10							
		09-10	B	PC3,4	E12	118433	CG	X	2.1,5	10							
	All, Incl. LX & EX	11-12	B	PC3,4	E10	118453	HG		2.1,7.5	10							
Rondo		07-10	B	SUV1,2	E14	118431	BN,CG	X	2.1,5	15							
Sedona		02-05	B	SUV1,2	E8	118309	HG		2.1,5	25							
	All Models	06-12	B,E	SUV1,2	E19	118410	BN,CH	X	2.1,5.6	45							
Sorento		03-06	B	SUV7	E7	118307	BN,HG		2.1,5	5							
	w/Factory Tow Package	07-09	B,E	SUV7			†,CH †,CH				E12 E13 E13	118250 118429 118529	CH CH CH	4-Flat 4-Flat 4-Flat	X X X	2.1,4.2 2.1,4.2 2.1,5.6	20 20 20
	Base I4	11	B,E	SUV1,2	E23	118506	CH	X	4.2,7.5	45							
	EX I4	11	B,E	SUV1,2	E23	118506	CH	X	4.2,7.5	45							
	EX V6 w/Factory Tow Package	11	B,E	SUV5	E18	118541	BN,CH	X	4.2,7.5	45							
	EX V6 w/o Factory Tow Package	11	B,E	SUV1,2	E23	118506	CH	X	4.2,7.5	45							
	LX I4	11	B,E	SUV1,2	E23	118506	CH	X	4.2,7.5	45							
	LX V6	11	B,E	SUV1,2	E23	118506	CH	X	4.2,7.5	45							
	SX V6	11	W	SUV5	E18	118541	BN,CH	X	4.2,7.5	45							
Soul		10-11	B	SUV1,2	E14	118431	BN,CG	X	2.1,5	15							
Sportage		98-02	B,F	SUV3,4	E12	118371	HG		2.1,5	20							
	6 Cyl. Models Only	05-10	B	SUV5	E8	118401	BN,CG	X	2.1,5	5							
	All Models	11-12	B,E	SUV1,5	E25	118526	CH	X	4.2,7.5	45							
LEXUS																	
ES 350		07-11	B,E	PC3,4	E16	118488	CH	X	2.1,5.6	45							
GX 460		10-11	A	SUV5							E12	118262 20119 118015 118384	BN,RD RD RD BN,RD	Both Both 7-Way 4-Flat		10 10 10 5	
	w/Factory 7-Way	10-11	A	SUV5							E8	20137	RD			10	
GX 470	w/Factory 7-Way	03-06	E	SUV1,2												10	
HS 250h	Hybrid	10-11	B,E	PC3,4	E17	118510	CH	X	2.1,5.6	20							
LX 450		96-97	B	SUV6	E5	118357	BN,HG		2.1,5	5							
LX 470		98-99	B	SUV6	E5	118365	BN,HG		2.1,5	5							
		01-07	B	SUV6							E3	118245	BN,HG	4-Flat		7.5 10	
LX 570		08-11	B	SUV6							E3	118245	BN,HG	4-Flat		7.5 10	
RX 300		01-03	E,Z	SUV1,2							E3	118245	BN,HG	4-Flat		7.5 10	

T-ONE® CONNECTOR APPLICATIONS

MAKE/MODEL	YEAR	ELEC	POS	T-ONE (4-Flat)					OEM Replacement							
				PC	Part No.	FN	CP	Amp	IN	PC	Part No.	FN	TYPE	CP	Amp	IN
LEXUS (Continued)																
RX 330	04-06	B,S	SUV3,4	E17	118478	CH	X	2.1,5.6	45							
RX 350	07-09	B,S	SUV3,4	E17	118478	CH	X	2.1,5.6	45							
	10-12	B,S	SUV3,4	E17	118478	CH	X	2.1,5.6	45	E13	118255	BN,CH	4-Flat	X	2.1,5.6	20
	w/Factory Tow Package	10-12	A	SUV6						E3	118252	BN,RD	4-Flat		7.5	5
RX 450h	Hybrid	10-12	E	SUV4						E13	118255	BN,CH	4-Flat	X	2.1,5.6	20
	Hybrid w/Factory Tow Package	10-12	A	SUV6						E3	118252	BN,RD	4-Flat		7.5	5
LINCOLN																
Aviator	03-04	A	SUV1,2	E4	118344	BN		7.5	10							
	w/Factory 7-Way	03-04	A	SUV6							20119	RD	Both			10
											118015	RD	7-Way			10
	w/Factory 7-Way	05	A	SUV6							118015	RD	7-Way			10
											20119	RD	Both			10
LS	00-06	G	PC3,4	E17	118373	LS		2.1,4.2	20							
Mark LT	w/Factory 7-Way	06-08	A	PU3							20119	RD	Both			10
											118015	RD	7-Way			10
MKS	09-12	W	PC3,4	E18	118471	CH	X	2.1,5.6	45							
MKT	All Models	10-12	A,E	SUV3,4	E18	118507	CH	X	2.1,5.6	45						
	w/Factory 7-Way	10-12	A	SUV6							118015	RD	7-Way			10
											20119	RD	Both			10
MKX	07-10	E,N	SUV1,2	E17	118551	CH	X	4.2,7.5	45							
	11-12	E,N	SUV1,2	E23	118519	CH	X	4.2,7.5	45							
MKZ	07-09	W	PC1,2	E17	118502	CH	X	2.1,5.6	45							
Navigator	98-03	A	SUV1,2	E4	118344	BN		7.5	10							
	w/Factory 7-Way	98-03	A	SUV6							20119	RD	Both			10
											118015	RD	7-Way			10
	w/Factory 7-Way	04-11	A	SUV6							118015	RD	7-Way			10
											20119	RD	Both			10
Zephyr	06	B,F	PC1,2	E17	118502	CH	X	2.1,5.6	45							
MAZDA																
2	11	B,E	PC3,4	E17	118520	CH	X	2.1,5.6	45							
3																
	4 Dr. Sedan, Except Models with Grand Touring LED Taillights Package	04-09	B	PC3,4	E14	118420	CG	X	2.1,5	15						
	5 Dr. Hatchback, Except Models with Grand Touring LED Taillights Package	04-09	B	PC3,4	E14	118420	CG	X	2.1,5	15						
	5 Dr. Hatchback, Except Models with Grand Touring LED Taillights Package	10-11	B	PC3,4	E14	118420	CG	X	2.1,5	15						
	4 Dr. Sedan, Except Models with Grand Touring LED Taillights Package	10-12	B	PC3,4	E14	118420	CG	X	2.1,5	15						
5	All Models	06-10	B,E	PC3,4	E17	118520	CH	X	2.1,5.6	45						
	All Models	12	B,E	PC3,4	E17	118520	CH	X	2.1,5.6	45						
6	4 Dr. Sedan	03-08	B,E	PC3,4	E16	118405	CH	X	2.1,5.6	45						
	5 Dr. Hatchback	04-08	B,E	PC3,4	E16	118405	CH	X	2.1,5.6	45						
	4 Dr. Sedan	09-12	B,E	PC3,4	E19	118483	CH	X	2.1,5.6	45						
CX-7	07-11	B,F	SUV3,4	E16	118405	CH	X	2.1,5.6	45							
	w/Factory Tow Package	07-11	B,F	SUV4						E12	118249	CH	4-Flat	X	2.1,4.2	5
CX-9	07-12	W	SUV3,4	E17	118520	CH	X	2.1,5.6	45							
Navajo	91-94	A	SUV1	E3	118324	BN		7.5	20							
Pickup B-Series	All Models	94-08	B	PU3	E7	118325	BN,HG		2.1,5	5						
	w/Factory Tow Package	98-01	A	SUV5						E1	118241	BN	4-Flat		7.5	5
Tribute	01-03	B	SUV1,2	E8	118343	HG,RW		2.1,5	10							
				E15	118345	BN,GC,RW		2.1,4.2	45							
		05-06	B,E	SUV1,2	E17	118426	BN,CH	X	2.1,4.2	45						
	All, Inc. Hybrid & Vehicles w/Backup Sensors	08-11	A	SUV1,2	E17	118551	CH	X	4.2,7.5	45						
	All, Inc. Hybrid & Vehicles w/o Backup Sensors	08-11	A	SUV5						E1	118251	BN,QP	4-Flat		7.5	5
MERCURY																
Grand Marquis	92-97	A,F	PC3,4	E9	118326			7.5	20							
Mariner																
	All, Inc. Hybrid & Vehicles w/Backup Sensors	05-07	A,E	SUV1,2	E17	118551	CH	X	4.2,7.5	45						
	All, Inc. Hybrid & Vehicles w/Backup Sensors	08-11	A	SUV1,2	E17	118551	CH	X	4.2,7.5	45						
	All, Inc. Hybrid & Vehicles w/o Backup Sensors	08-11	A	SUV5						E1	118251	BN,QP	4-Flat		7.5	5
Milan	06-09	W	PC1,2	E17	118502	CH	X	2.1,5.6	45							
	10-11	W	PC1,2	E17	118502	CH	X	2.1,5.6	45							
Monterey Van	04-07	E,N	SUV1,2	E17	118385	CH	X	2.1,5.6	45							

T-ONE® CONNECTOR APPLICATIONS

MAKE/MODEL	YEAR	ELEC	POS	T-ONE (4-Flat)						OEM Replacement					
				PC	Part No.	FN	CP	Amp	IN	PC	Part No.	FN	TYPE	CP	Amp
MERCURY (Continued)															
Mountaineer		B,E	SUV1,2	E15	118345	BN,GC		2.1,4,2	45						
	w/Factory Tow Package	97-01	A	SUV7						E1	118241	BN	4-Flat		7.5
		97-01	A	SUV7							20119	RD	Both		10
	w/Factory 7-Way	00-01	A	SUV6							118015	RD	7-Way		10
		02-03	A	SUV1,2	E4	118344	BN		7.5	10					
	02-03	A	SUV6							118015	RD	7-Way		10	
	04-10	A	SUV6							20119	RD	Both		10	
										20119	RD	Both		10	
										118015	RD	7-Way		10	
Sable	Sedan, All Models	92-95	A	PC3,4	E10	118351			7.5	10					
	Sedan, All Models	96-99	B	PC3,4	E9	118333	HG		2.1,5	10					
	Sedan, All Models	00-03	A	PC3,4	E4	118375			7.5	10					
	Sedan, All Models	08-09	A	PC3,4	E7	118447			7.5	10					
Tracer	4 Dr. Sedan	97-99	A	PC1,2	E4	118344			7.5	10					
Villager Mini Van		98	B	SUV3	E10	118362	BN,HG		2.1,5	5					
MITSUBISHI															
Endeavor		04-08	B,E	SUV3	E12	118516	CH	X	2.1,5,6	30					
		10-11	B,E	SUV3	E12	118516	CH	X	2.1,5,6	30					
Galant		07-11	B	PC3,4	E14	118420	CG	X	2.1,5	15					
Montero	Does Not Inc. Montero Sport	01-06	B	SUV1,2	E12	118380	BN,HG		2.1,5	20					
Outlander		03-06	B,F	SUV3,4	E8	118306	HG		2.1,5	25					
		07-11	B,F	SUV3,4	E18	118518	CH	X	4.2,7.5	45					
Outlander Sport		11	B,LD	SUV1,2	E16	118538	CH	X	2.1,5,6	45					
Raider		06-09	A	PU1,2	E16	118323	BN		7.5	10					
	w/Factory 7-Way	06-09	A	PU3							E3	20135	RD	Both	10
											118381	BN,RD	4-Flat	7.5	5
RVR	Canada Only	11	B,LD	SUV1,2	E16	118538	CH	X	2.1,5,6	45					
NISSAN															
Altima		98-01	B	PC3,4	E8	118361	HG		2.1,5	20					
	4 Dr. Sedan	07-12	B,E	PC3,4	E17	118470	CH	X	2.1,5,6	45					
	2 Dr. Coupe	08-12	B	PC3,4	E17	118470	CH	X	2.1,5,6	45					
Armada	w/Factory 7-Way	04-11	H	SUV6							E8	118384	BN,RD	4-Flat	7.5
											20119	RD	Both	10	
											118015	RD	7-Way	10	
Cube		09-11	B	SUV1,2	E15	118492	CG	X	2.1,7.5	45					
Frontier Pickup		98-04	B	PU4	E10	118362	BN,HG		2.1,5	5					
	All Models	05-11	H	PU3	E14	118525	BN		7.5	30					
	w/Factory Tow Package	05-11	B,E	PU3							E3	118263	RD,Z	4-Flat	7.5
		11	B,E	SUV3,4	E17	118528	CH	X	2.1,5,6	45					
JUKE		11	B,E	SUV3,4	E17	118528	CH	X	2.1,5,6	45					
Maxima	All Models	04-08	B,E	PC3,4	E17	118470	CH	X	2.1,5,6	45					
	All Models	09-11	B,E	PC3,4	E17	118470	CH	X	2.1,5,6	45					
Murano		09-11	BX	SUV3,4	E16	118481	CH	X	2.1,5,6	45					
NV1500	All Models	12	B,E	SUV3,4	E17	118553	CH	X	4.2,7.5	45					
NV2500 HD	All Models	12	B,E	SUV3,4	E17	118553	CH	X	4.2,7.5	45					
NV3500 HD	All Models	12	B,E	SUV3,4	E17	118553	CH	X	4.2,7.5	45					
Pathfinder		87-95	B	SUV1,2	E8	118353	BN,HG		2.1,5	10					
		96-04	B	SUV1,2	E8	118361	HG		2.1,5	20					
		05-11	B	SUV5	E3	118263	BN		7.5	5					
	All Models	05-11	H	SUV5	E14	118525	BN		7.5	30					
Pickup	(App. starts with 86-1/2)	86-97	B	PU1,2	E8	118353	BN,HG		2.1,5	10					
Quest Mini Van		98	B	SUV3	E10	118362	BN,HG		2.1,5	5					
		04-09	B,E	SUV1,2	E16	118469	CH	X	2.1,5,6	45					
		11	B,E	SUV1,2	E19	118547	BN,CH	X	4.2,7.5	45					
Rogue	All, Except Krom	08-12	B,E	SUV3,4	E15	118480	CH	X	2.1,5,6	45					
Sentra		07-12	B,E	PC3,4	E17	118470	CH	X	2.1,5,6	45					
Titan Pickup	w/Factory 7-Way	04-11	H	PU3							E8	118384	BN,RD	4-Flat	7.5
											118015	RD	7-Way	10	
											20119	RD	Both	10	
Versa	Sedan	07-11	B,E	PC3,4	E17	118545	CH	X	2.1,5,6	45					
	Hatchback	07-12	B,E	PC3,4	E17	118545	CH	X	2.1,5,6	45					
Xterra	w/Factory Tow Package	00-04	B	SUV7							E1	118244	BN	4-Flat	7.5
	All Models	05-11	H	SUV5	E14	118525	BN		7.5	30					
	w/Factory Tow Package	05-11	B,E	SUV5							E3	118263	BN,RD,Z	4-Flat	7.5

T-ONE® CONNECTOR APPLICATIONS

MAKE/MODEL	YEAR	ELEC	POS	T-ONE (4-Flat)						OEM Replacement								
				PC	Part No.	FN	CP	Amp	IN	PC	Part No.	FN	TYPE	CP	Amp	IN		
OLDSMOBILE																		
Bravada	w/Factory 7-Way	99-01	A	SUV6								E8	118384 20119 118015 20047	BN,RD RD RD RD	4-Flat Both 7-Way 7-Way		7.5	5 10 10 10
	w/Factory 7-Way	02-04	H	SUV6									118015 20047 118015 20119	RD RD RD RD	7-Way 7-Way 7-Way Both			10 10 10 10
												E8	118384	BN,RD	4-Flat		7.5	5
Custom Cruiser Wagon		91-92	A	PC3,4	E4	118352				7.5	10							
Silhouette		93-96	A,F	SUV1,2	E7	118337				7.5	20							
		97-04	B	SUV3	E8	118355	HG			2.1,5	10							
PLYMOUTH																		
Grand Voyager		91-95	A	SUV1,2	E16	118323	BN			7.5	10							
		96-00	B	SUV1,2	E10	118334	HG			2.1,5	20							
Trailduster		86-93	A	SUV5,7	E4	118317	BN			7.5	5							
Voyager		91-95	A	SUV1,2	E16	118323	BN			7.5	10							
		96-00	B	SUV1,2	E10	118334	HG			2.1,5	20							
PONTIAC																		
Aztek		01-05	A	SUV1,2	E10	118383	BN			7.5	20							
G3	5 Dr.	09	B	PC3,4	E13	118485	CG	X		2.1,7,5	15							
G5	2 Dr. Only	07-09	A	PC1,2	E5	118407	BN			7.5	15							
G5 GT	2 Dr. Only	07-09	A	PC1,2	E5	118407	BN			7.5	15							
G5 Pursuit	2 Dr. Only (Canada Only)	05-09	A	PC1,2	E5	118407	BN			7.5	15							
	4 Dr. (Canada Only)	05-09	A	PC1,2	E8	118398	BN			7.5	10							
G5 Pursuit GT																		
	2 Dr. Only (Canada Only)	05-09	A	PC1,2	E5	118407	BN			7.5	15							
	4 Dr. (Canada Only)	05-09	A	PC1,2	E8	118398	BN			7.5	10							
G6	All Models	05-09	A	PC1,2	E7	118439	BN			7.5	15							
Montana		99-05	B	SUV3	E8	118355	HG			2.1,5	10							
	(Canada Only)	07-09	A	SUV1,2	E8	118355	HG			2.1,5	10							
Montana SV6	All, Inc. AWD	05-06	A	SUV1,2	E10	118396	BN			7.5	15							
	All, Inc. AWD (Canada Only)	07-09	A	SUV1,2	E10	118396	BN			7.5	15							
Torrent		06	B	SUV3	E8	118391	CG	X		2.1,5	10							
		07-09	A	SUV3	E7	118432	CE			7.5	10							
Trans Sport Van		93-96	A	SUV1,2	E7	118337				7.5	20							
	All, Inc. Montana	97-98	B	SUV3	E8	118355	HG			2.1,5	10							
Vibe		03-08	B	SUV3,4	E11	118458	CG	X		2.1,5	15							
		09-10	B,E	SUV3,4	E16	118460	CH	X		2.1,4,2	45							
SAAB																		
9-7X	w/Factory 7-Way	05-09	H	SUV6								E8	118384 20119 118015 20047	BN,RD RD RD RD	4-Flat Both 7-Way 7-Way		7.5	5 10 10 10
SATURN																		
Aura		07-09	B,LD	PC1,2	E11	118423	BN,HG			2.1,4,2	15							
Outlook		07-09	A,N	SUV1,2	E10	118434	BN			7.5	15							
	w/Factory 7-Way	07-09	A,N	SUV6								E8	20047 118015 20119 118384	RD RD RD BN,RD	7-Way 7-Way Both 4-Flat		7.5	10 10 10 5
Relay		05-07	A	SUV1,2	E10	118396	BN			7.5	15							
Vue	All Models	02-07	B	SUV1,2	E16	118418	BN,CG	X		2.1,5	20							
	All Models	08-09	B,E	SUV3,4	E19	118443	CH	X		2.1,4,2	45							
SCION																		
tC		07-10	B	PC3,4	E13	118484	CG	X		2.1,5	15							
xB		04-07	B	SUV3,4	E12	118414	CG	X		2.1,5	20							
		08-10	B,E	SUV3,4	E18	118468	CH	X		2.1,5,6	45							
		11-12	B,E	SUV3,4	E16	118460	CH	X		2.1,4,2	45							
SUBARU																		
B9 Tribeca	All Models	06-11	B,F	SUV8	E12	118461	CH	X		2.1,4,2	10							
Forester		98-08	B,F	SUV4	E12	118461	CH	X		2.1,4,2	10							
		09-11	B,E	SUV8	E11	118467	CH	X		2.1,5,6	15							
Impreza	4 Dr. Sedan, Inc. WRX	08-11	B,E	PC3,4	E17	118464	CH	X		2.1,5,6	45							

T-ONE® CONNECTOR APPLICATIONS

MAKE/MODEL	YEAR	ELEC	POS	T-ONE (4-Flat)						OEM Replacement					
				PC	Part No.	FN	CP	Amp	IN	PC	Part No.	FN	TYPE	CP	Amp
SUBARU (Continued)															
Legacy Sedan	10-12	B,E	PC3,4	E13	118511	CH	X	2.1,5,6	45						
Legacy Wagon Outback Only	96-99	B,F	PC3,4	E12	118461	CH	X	2.1,4,2	10						
	05-07	B,F	PC3,4	E12	118461	CH	X	2.1,4,2	10						
Outback Wagon	00-09	B,F	PC3,4	E12	118461	CH	X	2.1,4,2	10						
	10-12	B,F	PC3	E11	118467	CH	X	2.1,5,6	15						
SUZUKI															
Equator All Models	09-11	H	PU3	E14	118525	BN		7.5	30						
w/Factory Tow Package	09-11	B,E	PU3							E3	118263	BN,RD,Z	4-Flat		7.5 5
Grand Vitara	99-05	B	SUV3	E5	118372	HG		2.1,5	5						
	06-11	B	SUV3,4	E12	118456	CG	X	2.1,5	20						
Sidekick	89-98	B	SUV3	E5	118372	HG		2.1,5	5						
SX4 Crossover	07-11	B	SUV3,4	E12	118456	CG	X	2.1,5	20						
Sport Sedan	08-11	B	PC3,4	E12	118475	CG	X	2.1,5	20						
Vitara	99-05	B	SUV3	E5	118372	HG		2.1,5	5						
XL-7	01-06	B	SUV3	E5	118372	HG		2.1,5	5						
w/Factory Tow Package	07-09	B	SUV3							E7	118432	CE,RD			7.5 10
TOYOTA															
4Runner	96-02	B,F	SUV3,4	E11	118341	HG		2.1,5	20						
	01-02	B,F	SUV3,4							E3	118245	BN,HG	4-Flat		7.5 10
w/Factory 7-Way	03-06	B	SUV1,2								20137	RD			10
	10-11	A	SUV5							E12	118262	BN,RD	Both		10
w/Factory 7-Way	10-11	A	SUV5								20119	RD	Both		10
											118015	RD	7-Way		10
										E8	118384	BN,RD	4-Flat		7.5 5
Avalon	11	B,E	PC3,4	E17	118482	CH	X	2.1,5,6	45						
Camry 4 Dr.	97-01	B	PC3,4	E8	118358	HG		2.1,5	5						
4 Dr.	02-06	B	PC3,4	E10	118308	HG		2.1,5	5						
4 Dr., Except Hybrid	07-09	B,F	PC3,4	E16	118405	CH	X	2.1,5,6	45						
4 Dr., Hybrid	07-11	B,LD	PC3,4	E17	118482	CH	X	2.1,5,6	45						
4 Dr., Except Hybrid	10-11	B,LD	PC3,4	E17	118482	CH	X	2.1,5,6	45						
4 Dr., Except Hybrid	12	B,F	PC3,4	E16	118405	CH	X	2.1,5,6	45						
Corolla	03	B	PC3,4	E13	118387	CG	X	2.1,5	15						
	09-11	B,E	PC3,4	E16	118459	CH	X	2.1,4,2	45						
Echo	00-02	B	PC3,4	E12	118386	CG	X	2.1,5	20						
FJ Cruiser	07-11	B	SUV3,4	E16	118405	CH	X	2.1,5,6	45						
Highlander	01-03	B,Z	SUV6							E3	118245	BN,HG	4-Flat		7.5 10
All, Except Hybrid	01-07	B,Z	SUV3,4	E10	118413	HG		2.1,4,2	20						
All, Inc. Hybrid	04-07	B	SUV3	E10	118248	CH	X	2.1,4,2	20						
All, Inc. Hybrid	08-11	B,E	SUV3,4	E13	118449	CH	X	2.1,4,2	20						
Hilux	08-12	B	PU3,4	E13	118496	BN,HG		2.1,7,5	10						
LandCruiser	96-97	B	SUV6	E5	118357	BN,HG		2.1,5	5						
	98-99	B	SUV6	E5	118365	BN,HG		2.1,5	5						
	01-02	B	SUV6							E3	118245	BN,HG	4-Flat		7.5 10
Matrix	03-08	B	SUV3,4	E12	118386	CG	X	2.1,5	20						
All Models	09-11	B,E	SUV3,4	E16	118460	CH	X	2.1,4,2	45						
Pickup All, Except T-100	89-95	B,F	PU1,2	E12	118379	BN,HG		2.1,5	10						
Prius	04-11	W	PC3,4	E16	118505	CH	X	2.1,5,6	25						
RAV4	96-00	B	SUV3,4	E12	118388	CG	X	2.1,5	20						
	01-05	B	SUV3,4	E12	118389	CG	X	2.1,5	20						
	06-11	W	SUV3,4	E16	118412	CH	X	2.1,4,2	45						
Sequoia	01-02	B	SUV7							E1	118246	BN	4-Flat		7.5 5
w/Factory 7-Way	03-04	RD	SUV6								20137	RD			10
Sienna Van	04-10	B	SUV1,2	E10	118304			2.1,5	20						
All Models	11-12	B,E	SUV1,2	E18	118498	CH	X	2.1,5,6	45						
T-100 Pickup	93-98	B	PU3,4	E13	118496	BN,HG		2.1,7,5	10						
Tacoma Pickup	(App. starts with 95-1/2)	B	PU1,2	E12	118379	BN,HG		2.1,5	10						
	05-08	B	PU1,2	E13	118496	BN,HG		2.1,7,5	10						
	09-12	B,LD	PU1,2	E13	118496	BN,HG		2.1,7,5	10						
w/Factory 7-Way	09-12	H	PU3								20119	RD	Both		10
										E8	118015	RD	7-Way		10
											118384	BN,RD	4-Flat		7.5 5

T-ONE® CONNECTOR APPLICATIONS

MAKE/MODEL	YEAR	ELEC	POS	T-ONE (4-Flat)						OEM Replacement					
				PC	Part No.	FN	CP	Amp	IN	PC	Part No.	FN	TYPE	CP	Amp
TOYOTA (Continued)															
Tundra	00	B,E	PU3	E15	118367	BN,GC		7.5	10						
	01-02	B,E	PU3	E17	118378	BN,GC		7.5	10						
	w/Factory 7-Way	03-06	B,E	PU3,4							20137	RD			10
	w/Factory 7-Way	10-12	H	PU3							20119	RD	Both		10
										118015	RD	7-Way		10	
										118384	BN,RD	4-Flat	7.5	5	
Venza	09-11	B,E	SUV3,4	E17	118482	CH	X	2.1,5.6	45						
Yaris Sedan	07-11	B,E	PC3,4	E18	118517	CH	X	2.1,5.6	45						
VOLKSWAGEN															
Jetta 4 Dr. Sedan (New Body Style)	05-10	AP	PC3,4	E22	118531	CH	X	4.2,7.5	45						
Passat Sedan	06-10	BM	PC1,2	E22	118530	CH	X	4.2,7.5	45						
Passat Wagon	07-10	BM	PC1,2	E22	118530	CH	X	4.2,7.5	45						
Routan	09-11	A	SUV1,2	E7	118490			7.5	20						
Touareg	04-10	B,E	SUV3,4	E22	118509	CH	X	4.2,7.5	45						
VOLVO															
S80 Sedan	07-11	E,MX	PC3,4	E19	118454	CH	X	2.1,5.6	45						
V70 Wagon All, Inc. AWD	08-10	E,MX	SUV3,4	E15	118463	CH	X	2.1,5.6	45						
XC60	10-12	BX	SUV3,4	E20	118523	CH	X	4.2,7.5	45						
XC90	05-12	E,MX	SUV3,4	E18	118411	CH	X	2.1,5.6	20						

†=Available while supply lasts.

1=Upgrades from OEM 4-Flat to 6-Way wiring.

2=Upgrades from OEM 4-Flat to 7-Way wiring.

A=2 wire system. No Converter required, but a ModuLite® can be used.

AP=2 wire system w/Pulse Width Modulation (PWM). Upgraded ModuLite® required.

B=3 wire system. Requires Converter, but a ModuLite® can be used.

BM=3 wire system. Upgraded ModuLite® HD required. Multiplexed Wiring System.

BN=Exterior mounted plug on some or all models. May require an aftermarket electrical mounting box or bracket. (Sold separately)

BP=3 wire system w/Pulse Width Modulation (PWM). Upgraded ModuLite® required.

BX=3 wire system. ModuLite® required. Multiplexed Wiring System.

CE=T-One includes fuse(s) & relay(s), converter not required. Standard 2 wire system at factory tow plug.

CG=T-One incorporates circuit protected taillight converter.

CH=T-One is equipped with circuit protected ModuLite® module.

E=ModuLite® required.

F=ModuLite® recommended.

FV=2003 Models w/Build date after 11/1/02.

FW=2003 Models w/Build date before 11/1/02.

G=Low-side switching system.

GC=T-One is equipped with ModuLite® Lite module.

H=3 wire system with OEM standard 2 wire harness.

HG=T-One incorporates taillight converter.

HJ=Per Dodge owner's manual: If trailer is equipped with more than standard lighting (1 taillight per side), use of ModuLite® or dealer supplied harness is required.

JM=Some early production 1994 models may require #118348.

LD=Vehicle has LED taillamps.

LS=T-One incorporates low-side switching taillight converter. Additional installation time required.

MX=Multiplexed Wiring System.

N=DO NOT cut or splice vehicle wiring. Only use approved T-One or see auto dealer for trailer tow wiring kit.

QP=Will not fit vehicles with backup sensors built into rear bumper.

RD=For vehicles equipped with factory tow package, may require additional components or may be used as a replacement harness.



Without **ModuLite®** or **ModuLite® HD** all the additional power required to supply the trailer lights (represented by the red line) pass through the vehicle's electrical system including the fuse panel, turn signal switch, taillight harness and lamp out sensor if so equipped.

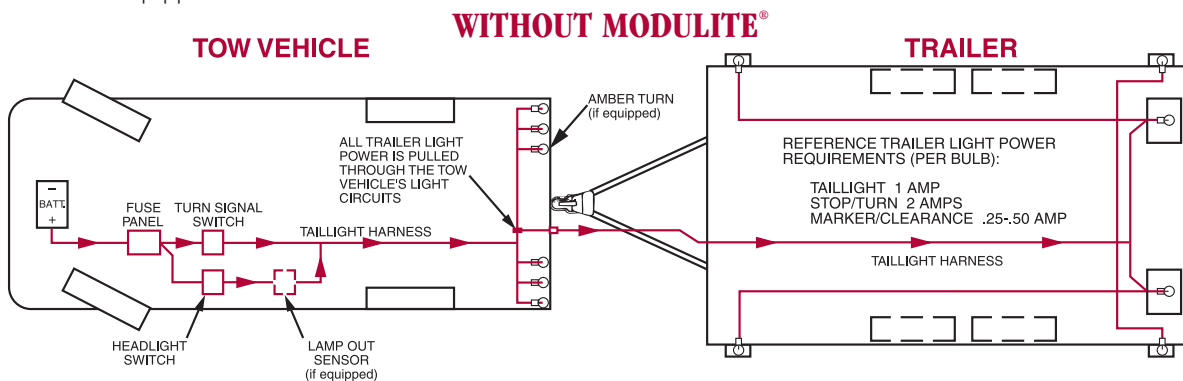

With **ModuLite®** all the additional power required to supply the trailer lights (represented by the green line) is supplied directly from the battery. Only a small amount of power is required from the fuse panel, turn signal switch, taillight harness and lamp out sensor if so equipped, to signal when to illuminate the trailer lights.

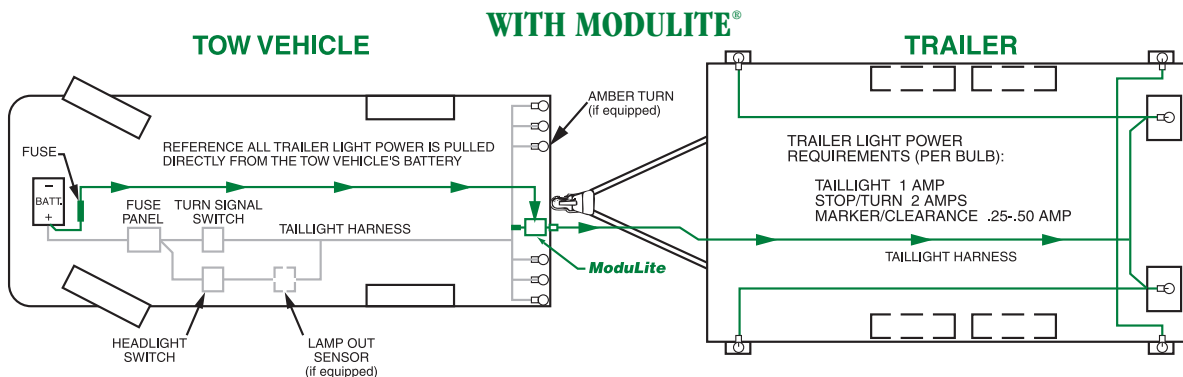

MODULITE POWER MODULES



TRAILER LIGHT POWER MODULES

- Virtually eliminates additional electrical draw on the vehicle's taillight circuits
- Ensures maximum trailer light brightness
- Powers the trailer's stop, turn, tail and running lights without overloading vehicle electrical systems
- Compatible with 2 & 3 wire systems
- Eliminates the need for heavy duty flashers

IDENTIFYING THE NEED FOR MODULITE®

- Today's vehicles have light gauge wire
- Computerized vehicle sensors monitor electrical current draw
- Without ModuLite® the sensors may give false readings
- Adding additional towing lights w/o ModuLite® may overload the system
- System problems and failure may occur without ModuLite®

HOW IT WORKS

- ModuLite® connects directly to vehicle's battery & powers the towing lights
- ModuLite® provides from 2.1 to 7.5 amps of power per circuit to the trailer lights, depending on the unit

HOW TO DETERMINE THE RIGHT MODULITE® FOR YOU

The converter you choose depends on the type of trailer you'll be towing and the car or truck you'll be towing it with. The electrical systems on some vehicles are designed to handle the power needs of the vehicle only. Be sure to consult your owner's manual for their recommendations.

- 2 wire systems have stop and turn on the same circuit
- 3 wire systems have brake and turn lights on separate circuits

INSTALLATION

ModuLite® power modules typically install in 30 to 45 minutes depending on the ease of routing the power supply wire from the battery to the rear of the vehicle.

COMPATIBLE VEHICLES FOR MODULITE®

- Vehicles that have separate turn and stop light circuits (3 wire system)
- ModuLite® can also be used on vehicles with standard 2 wire systems to reduce electrical load
- Hazard flasher override to illuminate the trailer brake lights during tow vehicle flasher operation is provided

WHEN YOU NEED MODULITE®

- Trailer has more than one light assembly per side and is equipped with multiple clearance or running lights
- If the tow vehicle may tow a variety of different trailers
- Vehicle is equipped with lamp out sensors or other electronic devices that could be damaged by voltage fluctuations
- Owners manual cautions against adding additional loads to electrical circuits

For example: Jeep Grand Cherokee

"Do not connect trailer lighting system directly to the lighting system of your vehicle. Failure to comply could damage the vehicles electrical system and/or result in personal injury."

Bulb Type	Candle Power	Rated Amps	Watts
57—1895	2	0.27	3.780
2057	32	2.10	26.880
	2	0.48	6.720
MR16	—	—	35
921	21	1.40	17.920
922	15	0.98	12.544
1141	21	1.44	18.432
93	15	1.04	13.312
105	12	1.07	13.696
1156	32	2.10	26.880
1157	32	2.10	26.880
	3	0.59	8.260
168	3	0.35	4.900
194	2	0.27	3.780

MODULITE POWER MODULES

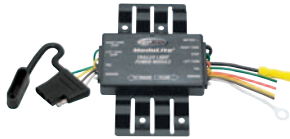

119146

New
Design/Features



119146



- 4.2 amps Turn/Stops
- 7.5 amps Taillight
- Integrated re-settable short circuit and overload protection

MODULITE® POWER MODULES

- Draws power directly from the vehicle battery and uses less than 5 mA of the vehicle circuit for sensing to turn the trailer functions on and off
- Will work with either LED/Incandescent bulbs (vehicle & trailer)
- The taillight circuit has been upgraded to work with vehicles that use a pulse width modulation (PWM), this will allow the converter to turn on fully and gives the trailer lights full brightness during activation
- The trailer brakes will override the hazard lamps when the brake is activated
- The unit is rated for up to 2.1 amps for Turns/Stops circuits and 7.5 amps for the Taillight circuit
- Will work with most vehicles that have a multiplex system for lighting
- Can be used on a 2 wire or 3 wire system
- Includes integrated protective cover

Part No.	Description	Packaging
119146	ModuLite® Power Module	Clam - Tow Ready
119146-012	ModuLite® Power Module (12 Pack)	Bulk
119146-050	ModuLite® Power Module (50 Pack)	Bulk



119176



119186

MODULITE® PROTECTOR WITH CIRCUIT PROTECTION

The ModuLite® with short circuit protector, adds integrated short circuit protection that safeguards itself and the tow vehicle against harmful electrical shorts and mis-wire situations.

- Draws power directly from the vehicle battery and uses less than 5 mA of the vehicle circuit for sensing to turn the trailer functions on and off
- Will work with most LED/Incandescent/Standard bulbs (vehicle & trailer)
- The unit is rated for up to 2.1 amps for Turns/Stops circuits and 5.6 amps for the Taillight circuit
- Will work with most vehicles that have a multiplex system for lighting
- The taillight circuit has been upgraded to work with vehicles that use a pulse width modulation (PWM), this will allow the converter to turn on fully and gives the trailer lights full brightness during activation
- This unit prevents feedback from trailer to the vehicle system
- Can be used on a 2 wire or 3 wire system
- Includes integrated protective cover

Part No.	Description	Packaging
119176	ModuLite® Protector Power Module	Clam - Tow Ready
119176-012	ModuLite® Protector Power Module (12 Pack)	Bulk
119176-050	ModuLite® Protector Power Module (50 Pack)	Bulk
119186	ModuLite® Protector Power Module & Wiring Kit (119176 & 118151)	Clam - Tow Ready

MODULITE POWER MODULES



119190

New Design



119191

HEAVY DUTY MODULITE® POWER MODULES WITH CIRCUIT PROTECTION

- Universal ModuLite designed to be used on most vehicles plus the hard to wire vehicles
- Converts vehicle functions from a 3 wire system to a trailer 2 wire system
- Can also be used on 2 wire vehicle systems
- Draws power directly from the vehicle battery and only uses less than 5 mA of the vehicle circuit for sensing to turn the trailer functions on and off
- Heavy-Duty! Rated for up to 4.2 amps for Turns/Stop circuits and 7.5 amps for the Taillight circuit
- Has integrated re-settable short circuit and overload protection, to safeguard itself and the tow vehicle from shorts and installation wiring mishaps
- All-solid state components in potted encapsulation
- Works with either LED or incandescent bulbs (input/output)
- Upgraded taillight circuit works with vehicles that use pulse width modulation (PWM); this gives trailer lights full brightness
- Designed not to send feedback thru the vehicle circuits
- Will work with most vehicles that have a multiplex system for lighting (i.e. vehicles – Audi, BMW, Mercedes and VW)
- Will not work with vehicles with low-side switch

Part No.	Description	Packaging
119190	Heavy Duty ModuLite® Power Module w/Circuit Protection	Clam - Tow Ready
119190-012	Heavy Duty ModuLite® Power Module (12 Pack)	Bulk
119190-050	Heavy Duty ModuLite® Power Module (50 Pack)	Bulk
119191	Heavy Duty ModuLite® Power Module w/Circuit Protection Includes Wiring Kit (119190 & 118151)	Clam - Tow Ready

MODULITE® WIRING KITS



118151

Part No.	Description	Packaging
118151	Wiring Kit For Installing All ModuLites®, Includes 10 Amp Fuse (20' Length)	Clam - Tow Ready

MODULITE POWER MODULES



119177

MODULITE® PROTECTOR W/INTEGRATED CIRCUIT & OVERLOAD PROTECTION

- Rated for up to 4.2 amps for Turns/Stop circuits, 7.5 amps for the Taillight circuit and 4.2 amps for Back up circuit
- Works with 2 or 3 wire light systems
- Draws power directly from the tow vehicle battery; uses less than 5 milliamps of the vehicle circuit
- Integrated 5-flat electrical wiring connector. Fifth circuit added for surge brake lockout or backup light circuit on trailers (some units will come with 5-way cap.... mounting bracket sold separately)
- Has integrated re-settable Short Circuit and Overload protection, to safeguard itself and the tow vehicle from shorts and installation wiring mishaps
- Designed not to send feedback thru the vehicle circuits
- Upgraded circuitry works with vehicles that use a pulse width modulation (PWM); this gives the trailer lights full brightness
- Will work with most vehicles that have a multiplex system for lighting (i.e. vehicles – Audi, BMW, Mercedes and VW)
- The trailer brakes will override the hazard lamps when the brake is activated)

Part No.	Description	Packaging
119177	ModuLite® Protector w/Integrated Circuit & Overload Protection & 5-Flat Connector for Backup Light or Surge Brake Lockout Circuit	Clam - Tow Ready



119192

MODULITE® ULTRA TRAILER LIGHT POWER MODULE

- Works with 2 or 3 wire light systems
- Works with either LED or Incandescent bulbs
- 16 amps for the taillight circuit and 4.2 amps for the turn/stop circuits
- Draws power directly from the tow vehicle battery; uses less than 5 milliamps of the vehicle circuit.
- Has integrated re-settable Short Circuit and Overload protection, to safeguard itself and the tow vehicle from shorts and installation wiring mishaps.
- Designed not to send feedback thru the vehicle circuits.
- Upgraded circuitry works with vehicles that use a pulse width modulation (PWM); this gives the trailer lights full brightness
- Interprets/decodes multiplex signal inputs (i.e. vehicles – Audi, BMW, Mercedes and VW)

Part No.	Description	Packaging
119192	ModuLite® Ultra Trailer Light Power Module	Clam - Tow Ready

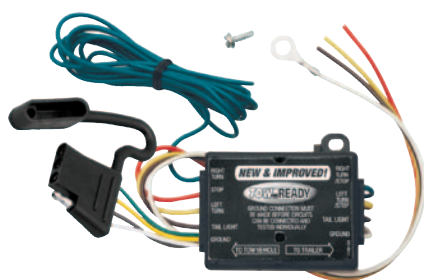

119130



707295

TAILLIGHT CONVERTERS

- Adapts import and domestic vehicles with separate turn and stop lights (3 wire system) to standard trailer taillight wiring (2 wire system)
- The unit is rated for up to 2.1 amps for Turns/Stops circuits and 7.5 amps for the Taillight circuit
- Will work with most LED/Incandescent/Standard bulbs (vehicle & trailer)
- Will work with most vehicles that have a multiplex system for lighting
- This unit prevents feedback from trailer to the vehicle system

Part No.	Description	Packaging
119130	Taillight Converter, Incl. 18" Blunt Leads & 4-Flat W/60"	Clam - Tow Ready
119130-012	Taillight Converter (12 Pack)	Bulk
119130-050	Taillight Converter (50 Pack)	Bulk
707295	Taillight Converter w/12" Leads and 60" 4-Flat Car End Connector	Clam - Wesbar



119175

Integrated Short Circuit Protection Safeguards itself and the tow vehicle against harmful electrical shorts and mis-wire situations.

TAILLIGHT CONVERTERS WITH CIRCUIT PROTECTION

Adds integrated short circuit protection that safeguards itself and the tow vehicle against harmful electrical shorts and mis-wire situations.

- Adapts import and domestic vehicles with separate turn and stop lights (3 wire system) to standard trailer taillight wiring (2 wire system)
- The unit is rated for up to 2.1 amps for Turns/Stops circuits and 7.5 amps for the Taillight circuit
- Includes integrated protective cover

Part No.	Description	Packaging
119175*	Taillight Converter, Incl. 18" Blunt Leads & 4-Flat W/60" Lead	Clam - Tow Ready
119175-012	Taillight Converter (12 Pack)	Bulk
119175-050	Taillight Converter (50 Pack)	Bulk

* Will Not Work With Vehicles With LED's

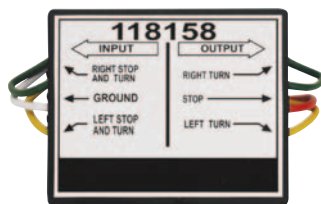

118158

2 TO 3-WAY TAILLIGHT CONVERTERS

- Allows R.V.'s & other vehicles with 2 wire systems to tow vehicles and trailers with 3 wire systems

Part No.	Description	Packaging
118158	Connects A Tow Vehicle With A 2 Wire System To A Towed Vehicle With A 3 Wire System	Clam - Tow Ready

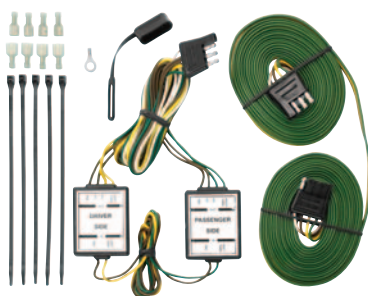

118821

TAILLIGHT ISOLATING DIODE SYSTEM

- Allows motorhome to power lights on towed vehicle w/o power feedback

Part No.	Description	Packaging
118821	Taillight Isolating System With 4-Flat	Clam - Tow Ready



MULTI-FIT WIRING HARNESS

- Easy do-it-yourself tow vehicle wiring kits for applications without T-One® Connectors
- Test light included on 20251 & 20252
- 16 gauge wire w/4-Flat dust cover

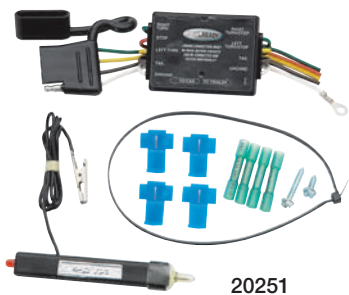

Part No.	Description	Packaging
20250	Vehicles w/common turn and stop lights and factory (O.E.M.) wiring harness. 12" length	Clam - Tow Ready
20251	Designed for vehicles w/ separate turn and stop lights and no factory (O.E.M.) wiring harness. Converter specification of 2.1 amps per stop/turn circuit & 4.2 amps per tail circuit. Includes circuit tester & 60" leads.	Clam - Tow Ready
20252	Vehicles w/common turn and stop lights and no factory (O.E.M.) wiring harness. Includes circuit tester. 72" length	Clam - Tow Ready

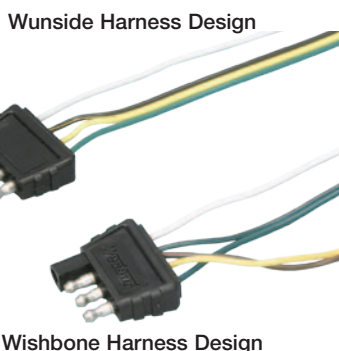
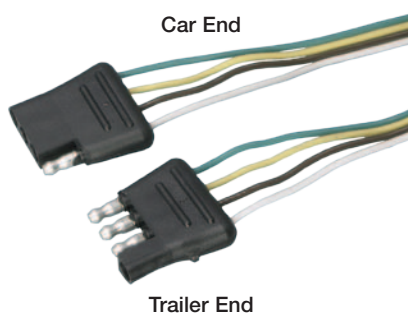

Note: Various length and combinations available. Contact your Cequent Performance Products Representative for details.

Note: All Cequent Performance Products 4-Way Flat Wire Harnesses conform to SAE J1128 interface specifications.

4-WAY FLAT WIRE HARNESSSES

Color coded harnesses in various lengths available with car and trailer end connectors. Trailer ends can be purchased in straight lengths, loops, wunside or wishbone harness styles. Various length and combinations are available.

4-Way Flat Car End Wire Harnesses

Part No.	Description	Packaging
002301	4-Way Flat 4 Ft. Car End, 18" Ground	Bulk
707275	4-Way Flat 4 Ft. Car End, 18" Ground	Clam - Wesbar
101469	4-Way Flat 6 Ft. Car End, 6 Ft. Ground	Bulk
707272	4-Way Flat 6 Ft. Car End, 6 Ft. Ground	Clam - Wesbar

4-Way Flat Trailer End Wire Harnesses

Part No.	Description	Packaging
18004001	4-Way Flat 12" Trailer End	Bulk

4-Way Flat Car End and Trailer End Wire Harnesses - Loop Style

Part No.	Description	Packaging
18185001	4-Way Flat 18" Loop w/Wire Taps	Bulk
18044001	4-Way Flat 48" Loop w/Wire Taps	Bulk
18045001	4-Way Flat 60" Loop w/Wire Taps	Bulk

4-Way Flat Trailer End Wire Harnesses - Wunside Style

Part No.	Description	Packaging
002401	4-Way Flat 18" Trailer End, Wunside Harness, 18" Ground	Bulk
707285	4-Way Flat 18" Trailer End, Wunside Harness, 18" Ground	Clam - Wesbar
002120	4-Way Flat 20 Ft. Trailer End, Wunside Harness, 3 Ft. Ground	Bulk
002125	4-Way Flat 25 Ft. Trailer End, Wunside Harness, 3 Ft. Ground	Bulk
002130	4-Way Flat 30 Ft. Trailer End, Wunside Harness, 3 Ft. Ground	Bulk

4-Way Flat Trailer End Wire Harnesses - Wishbone Style

Part No.	Description	Packaging
002402	4-Way Flat 18" Trailer End, Wishbone Harness, 18" Ground	Bulk
707286	4-Way Flat 18" Trailer End, Wishbone Harness, 18" Ground	Clam - Wesbar
002215	4-Way Flat 15 Ft. Trailer End, Wishbone Harness, 3 Ft. Ground	Bulk
002220	4-Way Flat 20 Ft. Trailer End, Wishbone Harness, 3 Ft. Ground	Bulk
108820	4-Way Flat 20 Ft. Trailer End, Wishbone Harness, 30" Ground	Bulk
707261	4-Way Flat 25 Ft. Trailer End, Wishbone Harness, 3 Ft. Ground	Clam - Wesbar
108825	4-Way Flat 25 Ft. Trailer End, Wishbone Harness, 3 Ft. Ground	Bulk
002230	4-Way Flat 30 Ft. Trailer End, Wishbone Harness, 3 Ft. Ground	Bulk
108830	4-Way Flat 30 Ft. Trailer End, Wishbone Harness, 3 Ft. Ground	Bulk
002235	4-Way Flat 35 Ft. Trailer End, Wishbone Harness, 3 Ft. Ground	Bulk
108835	4-Way Flat 35 Ft. Trailer End, Wishbone Harness, 30" Ground	Bulk
002240	4-Way Flat 40 Ft. Trailer End, Wishbone Harness, 3 Ft. Ground	Bulk
108840	4-Way Flat 40 Ft. Trailer End, Wishbone Harness, 3 Ft. Ground	Bulk

4-Way Flat Trailer End Wire Harnesses With Car Ends - Wishbone Style

Part No.	Description	Packaging
707270	4-Way Flat 18" Trailer End, Wishbone Harness, 18" Ground w/4 Ft. Car End, 18" Ground	Clam - Wesbar
707103	4-Way Flat 25 Ft. Trailer End, Wishbone Harness Kit w/Hardware, 3 Ft. Ground w/4 Ft. Car End, 18" Ground	Clam - Wesbar
707104	4-Way Flat 30 Ft. Trailer End, Wishbone HarnessKit w/Hardware, 3 Ft. Ground w/4 Ft. Car End, 18" Ground	Clam - Wesbar

Double Ended 4-Way Flat Wire Harness - Extension Style

Part No.	Description	Packaging
707254	Double Ended 4-Way 2 Ft. Cord (4-Way Flat Car & Trailer Ends)	Clam - Wesbar



4-WAY FLAT WIRE HARNESSSES

All Tow Ready® 4-Flat Wiring conforms to SAE Spec. J1128 assuring you of consistent quality and reliability. 4-Flat harnesses come in a variety of lengths and packages to fit your every need.

Features Include:

- 18 gauge bonded wires
- Taillight, stop and turn functions printed on wire
- Ground wire runs full length of assembly

4-WAY FLAT CAR END WIRE HARNESSSES

- 7.5 Amps max per circuit

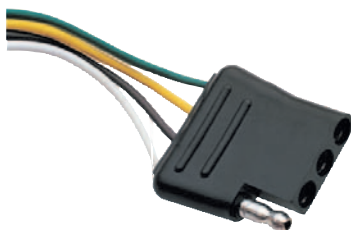

Part No.	Description	Packaging
118001	48" Car End - Includes 4 Wire Taps	Clam - Tow Ready
118001-024	48" Car End (24 Pack)	Boxed
118001-200	48" Car End (200 Pack)	Boxed
118002	60" Car End - Includes 4 Wire Taps	Clam - Tow Ready
118002-024	60" Car End (24 Pack)	Boxed
118002-200	60" Car End (200 Pack)	Boxed
118172-024	72" Car End (24 Pack)	Boxed
118172-150	72" Car End (150 Pack)	Boxed

4-WAY FLAT TRAILER END WIRE HARNESSSES

- 7.5 Amps max per circuit



Part No.	Description	Packaging
118004	12" Trailer End	Clam - Tow Ready
118004-012	12" Trailer End (12 pack)	Boxed
118009	21' Trailer End	Clam - Tow Ready
118033	48" Trailer End	Clam - Tow Ready
118033-012	48" Trailer End (12 pack)	Bagged
118192	25' Trailer End w/dual taillight (brown) wires	Clam - Tow Ready

4-WAY FLAT CAR AND TRAILER WIRE HARNESSSES

- 7.5 Amps max per circuit
- Includes both car and trailer 4-Flat Connectors wired end to end

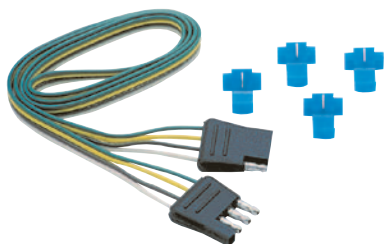

Part No.	Description	Packaging
118044	48" Car & Trailer End Loop - includes 4 wire taps	Clam - Tow Ready
118044-010	48" Car & Trailer End Loops (10 pack)	Bagged
118044-175	48" Car & Trailer End Loops (175 pack)	Boxed
118045	60" Car & Trailer End Loop - includes 4 wire taps	Clam - Tow Ready
118045-010	60" Car & Trailer End Loops (10 pack)	Boxed
118045-175	60" Car & Trailer End Loops (175 pack)	Boxed
118615-020	72" Car & Trailer End Loops (20 pack)	Boxed
118636	24' Car & Trailer End Loop	Clam - Tow Ready
118185	18" Car & Trailer End Loop - includes 4 wire taps	Clam - Tow Ready
118185-025	18" Car & Trailer End Loops (25 pack)	Bagged
118185-200	18" Car & Trailer End Loops (200 pack)	Boxed



4-WAY METAL CONNECTORS



Long wearing; rust and corrosion resistant, heavy duty metal. Spring loaded cover keeps dirt and moisture out when not in use. Positive lock prevents accidental disengagement. Coded terminals for easy access and handle grips for easier plug-in and disconnection.

Part No.	Description	Packaging
42-S	4-Way Metal Car End Only	Display Box - Tekonsha
43-S	4-Way Metal Trailer End Only	Display Box - Tekonsha

4-WAY ROUND ELECTRICAL CONNECTORS



- Attractive chrome housing

Part No.	Description	Packaging
118077	4-Way Round Chrome Car End & Trailer End Plug Connectors	Bulk
118101	4-Way Round Chrome Car End Connector	Bulk
118102	4-Way Round Chrome Trailer End Connector	Bulk

4-FLAT CAR END CONNECTORS



118043

- 7.5 Amps max per circuit

Part No.	Description	Packaging
118043	30" Car End "Knockout" Socket Connector 16 Gauge Wire (Un-Bonded). Requires 1-1/4" Hole.	Clam - Tow Ready
118603	60" Car End "Knockout" Socket Connector 16 Gauge Wire (Un-Bonded). Requires 1-1/4" Hole.	Clam - Tow Ready



4-WAY FLAT CONNECTORS WITH JACKETED CABLE



Color coded sealed cable available with trailer end connector, jacketed cable and 4' stripped wire leads. No exposed wires and sealed for environmental protection.

4-Way Flat Trailer End Connectors With Jacketed Cable

Part No.	Description	Packaging
787264	4-Way Flat 4' Trailer End w/Jacketed Cable	Bulk
787268	4-Way Flat 8' Trailer End w/Jacketed Cable	Bulk
787270	4-Way Flat 10' Trailer End w/Jacketed Cable	Bulk
787274	4-Way Flat 14' Trailer End w/Jacketed Cable	Bulk

Note: Various length and combinations available. Contact your Cequent Performance Products Representative for details.

Double Ended 4-Way Flat Connector With Jacketed Cable - Extension Stylee

Part No.	Description	Packaging
787159	Double Ended 4-Way 88" Cord (4-Way Flat Car and Trailer Ends)	Bulk



2-WAY FLAT WIRE HARNESS



- 2-Flat hookup - 12" loop

Part No.	Description	Packaging
118022	2-Flat Electrical Connector Loop - 12"	Clam - Tow Ready



787301

4-WAY FLAT DUST COVER

Part No.	Description	Packaging
787301	4-Way Flat Dust Cover	Clam - Wesbar



20112

4-WAY FLAT DUST COVER



Part No.	Description	Packaging
20112	Dust Cover For 4-Flat Connector	Clam - Tow Ready
20112-024	Dust Cover For 4-Flat Connector (24 Pack)	Boxed



118147-025

4-WAY FLAT COVER W/LED TESTER



Part No.	Description	Packaging
118147-025	4-Flat Cover w/LED Tester (25 pack)	Bagged



20118

5-WAY FLAT DUST COVER



Part No.	Description	Packaging
20118	Dust Cover, 5-Flat Connector	Clam - Tow Ready
20118-024	Dust Cover, 5-Flat Connector (24 pack)	Boxed

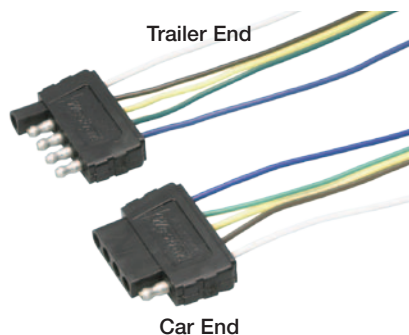

Trailer End

Car End

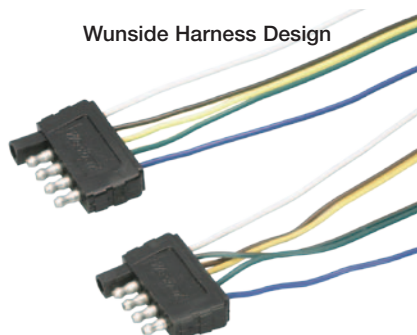

Wunside Harness Design

Wishbone Harness Design

Note: Various length and combinations available. Contact your Cequent Performance Products Representative for details.

5-WAY FLAT WIRE HARNESSSES

Color coded harnesses in various lengths available with car and trailer end connectors. Trailer ends can be purchased in wunside or wishbone harness styles. Various length and combinations are available.

5-Way Flat Car End Wire Harnesses

Part No.	Description	Packaging
702305	5-Way Flat 4 Ft. Car End , 18" Ground, 4 Ft. Auxiliary	Clam - Wesbar
002309	5-Way Flat 6 Ft. Car End, 6 Ft. Ground, 6 Ft. Auxiliary	Bulk
707273	5-Way Flat 6 Ft. Car End, 6 Ft. Ground, 6 Ft. Auxiliary	Clam - Wesbar

5-Way Flat Trailer End Wire Harnesses - Wunside Style

Part No.	Description	Packaging
702405	5-Way Flat 18" Trailer End, Wunside Harness, 18" Ground, 18" Auxiliary	Clam - Wesbar

5-Way Flat Trailer End Wire Harnesses - Wishbone Style

Part No.	Description	Packaging
002409	5-Way Flat 4 Ft. Trailer End, Wishbone Harness, 4 Ft. Ground, 4 Ft. Auxiliary	Bulk
707283	5-Way Flat 4 Ft. Trailer End, Wishbone Harness, 4 Ft. Ground, 4 Ft. Auxiliary	Clam - Wesbar
002275	5-Way Flat 25 Ft. Trailer End, Wishbone Harness, 4 Ft. Ground, 5 Ft. Auxiliary	Bulk
702275	5-Way Flat 25 Ft. Trailer End, Wishbone Harness, 4 Ft. Ground, 5 Ft. Auxiliary	Clam - Wesbar
002280	5-Way Flat 30 Ft. Trailer End, Wishbone Harness, 4 Ft. Ground, 5 Ft. Auxiliary	Bulk
002285	5-Way Flat 35 Ft. Trailer End, Wishbone Harness, 4 Ft. Ground, 5 Ft. Auxiliary	Bulk
002290	5-Way Flat 40 Ft. Trailer End, Wishbone Harness, 4 Ft. Ground, 5 Ft. Auxiliary	Bulk

5-Way Flat Trailer End Wire Harnesses With Car End - Wishbone Style

Part No.	Description	Packaging
707105	5-Way Flat 25 Ft. Trailer End, Wishbone Harness Kit w/Hardware, 4 Ft. Ground, 5 Ft. Auxiliary w/6 Ft. Car End, 6 Ft. Ground, 6 Ft. Auxiliary	Clam - Wesbar

Double Ended 5-Way Flat Wire Harness - Extension Style

Part No.	Description	Packaging
707255	Double Ended 5-Way 2 Ft. Cord (5-Way Flat Car and Trailers Ends)	Clam - Wesbar

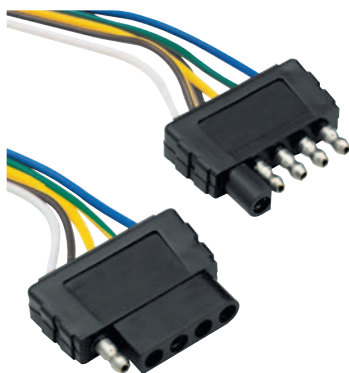

5-WAY FLAT ELECTRICAL WIRE HARNESSSES



- Fifth wire added for surge brake lockout or backup light circuit on today's newer trailers
- 7.5 amps maximum per circuit

Part No.	Description	Packaging
118016	5-Flat 72" Car End Wiring Harness	Clam - Tow Ready
118016-025	5-Flat 72" Car End Wiring Harness (25 pack)	Boxed
118017	5-Flat 48" Trailer End Wiring Harness	Clam - Tow Ready
118215	5-Flat 72" Car & Trailer End Loop	Clam - Tow Ready



6-WAY METAL CONNECTORS

Heavy duty die cast corrosion resistant housing, spring loaded car end cover, and coded terminals. Interchangeable with other standard 6-way connectors.



Part No.	Description	Packaging
62	6-Way Metal Car End Only	Bulk
54-60-101	6-Way Metal Car End Only	Bagged - Bargman
63	6-Way Metal Trailer End Only	Bulk
54-60-103	6-Way Metal Trailer End Only	Bagged - Bargman



6-WAY ZINC DIE CAST CONNECTORS

Round brass split pins to insure good contact. Floating male pins promote easy connect and disconnect. Interchangeable with all popular 6-way connectors.

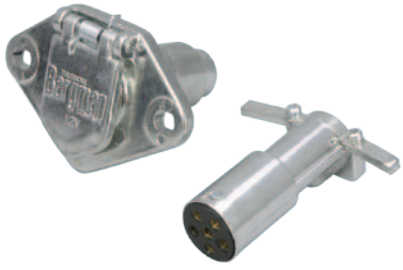

Part No.	Description	Packaging
50-60-001	6-Way Die Cast Car End Only	Bulk
51-60-001	6-Way Die Cast Car End Only	Clam - Bargman
54-60-001	6-Way Die Cast Car End Only	Bagged - Bargman
50-60-003	6-Way Die Cast Trailer End Only	Bulk
51-60-003	6-Way Die Cast Trailer End Only	Clam - Bargman
54-60-003	6-Way Die Cast Trailer End Only	Bagged - Bargman



6-WAY ELECTRICAL CONNECTORS

- Durable metal shell



Part No.	Description	Packaging
118036	6-Way Heavy-Duty Metal Car End Socket Connector	Clam - Tow Ready
118036-006	6-Way Heavy-Duty Metal Car End Socket Connectors (6 pack)	Bagged
118036-050	6-Way Heavy-Duty Metal Car End Socket Connectors (50 pack)	Boxed
118037	6-way Heavy-Duty Metal Trailer End Plug Connector	Clam - Tow Ready
118037-006	6-Way Heavy-Duty Metal Trailer End Plug Connectors (6 pack)	Bagged
118037-050	6-Way Heavy-Duty Metal Trailer End Plug Connectors (50 pack)	Boxed



6-WAY SQUARE WIRE HARNESSES

- Used on tent trailers
- 7.5 amps maximum per circuit

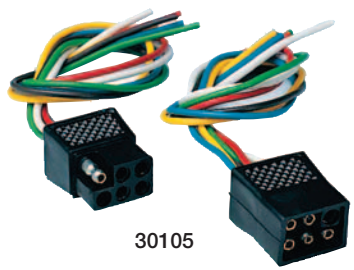

30105

Part No.	Description	Packaging
30105	6-Way Square Connector Kit (Male & Female Ends) - 12"	Clam
118104	6-Way Square to 4-Flat Adapter - 12" Loop	Bagged



118104



6-WAY SUPER SEALED CAR ENDS WITH CABLE

Prewired, 6-Way car end sealed with 2, 4 or 7 ft. of UL listed 6-way cable (White, Blue and Red-10 gauge; Yellow, Brown and Green-14 gauge). Solid brass terminals and housing of industrial-strength, glass-filled thermoplastic, door with EPDM rubber gasket and heavy duty stainless steel spring. Manufactured with UL listed PVC for flexibility and features molded construction to encapsulate terminals and wires. Patent Pending.

Part No.	Description	Packaging
50-86-004	6-Way Super Sealed Car End w/4 Ft. Cable	Bulk
51-86-004	6-Way Super Sealed Car End w/4 Ft. Cable	Clam - Bargman
50-86-007	6-Way Super Sealed Car End w/7 Ft. Cable	Bulk
51-86-007	6-Way Super Sealed Car End w/7 Ft. Cable	Clam - Bargman



6-WAY MOLDED TRAILER END CONNECTORS WITH CABLE

6-Way heavy duty series molded connector available with two different wires. Can be purchased with 3-10 gauge and 3-14 gauge wires (primary wire gauges; Yellow, Brown, Green - 14 gauge) or can be purchased with 6-14 gauge wires. Both models feature encapsulated terminals and wires to form one weather resistant, non-corrosive assembly. Molded connector can be used with thermo-plastic or metal 6-way car end connectors. Various length and combinations are available.

6-Way Molded Trailer End with Cable, 3-10 gauge, 3-14 gauge

Part No.	Description	Packaging
50-61-008	6-Way Molded Trailer Cord w/8 Ft. Cable, 3-10 gauge, 3-14 gauge	Bulk
51-61-008	6-Way Molded Trailer Cord w/8 Ft. Cable, 3-10 gauge, 3-14 gauge	Clam - Bargman

Note: Various length and combinations available. Contact your Cequent Performance Products Representative for details.

6-Way Molded Trailer End with Cable, 6-14 gauge

Part No.	Description	Packaging
50-61-104	6-Way Molded Trailer Cord w/4 Ft. Cable, 6-14 gauge	Bulk
50-61-106	6-Way Molded Trailer Cord w/6 Ft. Cable, 6-14 gauge	Bulk
50-61-108	6-Way Molded Trailer Cord w/8 Ft. Cable, 6-14 gauge	Bulk



7-WAY THERMO-PLASTIC CONNECTORS



12-volt thermo-plastic connector with brass contact to prevent corrosion. Built-in cable clamp prevents wear on 7-way cable. Unique method of forming contact pins provides for easy connecting and disconnecting.

Part No.	Description	Packaging
50-77-001	7-Way Plastic Car End Only	Bulk
51-77-001	7-Way Plastic Car End Only	Clam - Bargman
54-77-001	7-Way Plastic Car End Only	Bagged - Bargman
50-77-003	7-Way Plastic Trailer End Only	Bulk
51-77-003	7-Way Plastic Trailer End Only	Clam - Bargman
54-77-003	7-Way Plastic Trailer End Only	Bagged - Bargman



7-WAY METAL CONNECTORS

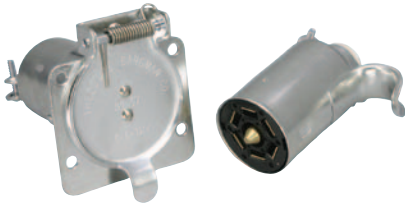

12-volt metal connector with plastic core. Metal housing is 20 gauge steel, zinc plated to protect against corrosion. Trigger grip for easy disconnection.

Part No.	Description	Packaging
50-57-503	7-Way Metal Car End Only	Bulk
51-57-503	7-Way Metal Car End Only	Clam - Bargman
54-57-503	7-Way Metal Car End Only	Bagged - Bargman
50-57-007	7-Way Metal Trailer End Only	Bulk
51-57-007	7-Way Metal Trailer End Only	Clam - Bargman
54-57-007	7-Way Metal Trailer End Only	Bagged - Bargman

7-WAY STANDARD ELECTRICAL CONNECTORS



- Available with metal or plastic shell
- RV blade style



Part No.	Description	Packaging
118020	7-Way Plastic Car End Socket Connector	Clam - Tow Ready
118020-006	7-Way Plastic Car End Socket Connectors (6 pack)	Bulk
118020-050	7-Way Plastic Car End Socket Connectors (50 pack)	Boxed
118021	7-Way Plastic Trailer End Plug Connector	Clam - Tow Ready
118021-006	7-Way Plastic Trailer End Plug Connectors (6 pack)	Bulk
118021-050	7-Way Plastic Trailer End Plug Connectors (50 pack)	Boxed
118031	7-Way Metal Trailer End Plug Connector	Clam - Tow Ready

7-WAY SUPER SEALED CAR ENDS WITH CABLE



Prewired 7-way car end sealed with 2, 4, 7 or 9 ft. of UL listed 7-way cable. Solid brass terminals, housing of industrial-strength, glass-filled thermoplastic, door with EPDM rubber gasket and heavy duty stainless steel spring. Manufactured with UL listed PVC for flexibility and features molded construction to encapsulate terminals and wires. Patent Pending.



Part No.	Description	Packaging
51-87-002	7-Way Super Sealed Car End w/2 Ft. Cable	Clam - Bargman
50-87-004	7-Way Super Sealed Car End w/4 Ft. Cable	Bulk
51-87-004	7-Way Super Sealed Car End w/4 Ft. Cable	Clam - Bargman
50-87-007	7-Way Super Sealed Car End w/7 Ft. Cable	Bulk
51-87-007	7-Way Super Sealed Car End w/7 Ft. Cable	Clam - Bargman
50-87-009	7-Way Super Sealed Car End w/9 Ft. Cable	Bulk



Note: Various length and combinations available. Contact your Cequent Performance Products Representative for details.

7-WAY MOLDED TRAILER END CONNECTORS WITH CABLE

7-way plastic trailer connector molded to heavy duty 7-way insulated cable. Made with self-cleaning contacts and molded to encapsulate terminals and wires to form one weather resistant, non-corrosive assembly. Primary wire gauges within the insulated cable are: Black and White-10 gauge, Blue-12 gauge, Brown-Red-Green-Yellow-14 gauge. Molded connector can be used with thermo-plastic or metal 7-way car end connectors. Various length and combinations are available.

7-Way Cable

Part No.	Description	Packaging
50-07-001	7-Way Cable UL Listed Wire	Bulk

7-Way Molded Trailer End with Cable

Part No.	Description	Packaging
50-67-001	7-Way Molded Trailer Cord w/6 Ft. Cable	Bulk
51-67-001	7-Way Molded Trailer Cord w/6 Ft. Cable	Clam - Bargman
50-67-002	7-Way Molded Trailer Cord w/7 Ft. Cable	Bulk
50-67-003	7-Way Molded Trailer Cord w/8 Ft. Cable	Bulk
51-67-003	7-Way Molded Trailer Cord w/8 Ft. Cable	Clam - Bargman
50-67-004	7-Way Molded Trailer Cord w/9 Ft. Cable	Bulk
50-67-005	7-Way Molded Trailer Cord w/10 Ft. Cable	Bulk

7-Way Molded Trailer End with Cable and 7-Way Metal Car End and Bracket

Part No.	Description	Packaging
50-67-503	7-Way Molded Trailer Cord w/8 Ft. Cable, 7-Way Metal Car End and Bracket	Bulk

7-Way Molded Trailer End with Cable and 7-Way Plastic Car End and Bracket

Part No.	Description	Packaging
50-77-510	7-Way Molded Trailer Cord w/7 Ft. Cable, 7-Way Plastic Car End and Bracket	Bulk

7-Way Molded Trailer End with Cable and Breakaway Switch

Part No.	Description	Packaging
50-67-408	7-Way Molded Trailer w/8 Ft. Cable and Breakaway Switch	Bulk
51-67-408	7-Way Molded Trailer w/8 Ft. Cable and Breakaway Switch	Clam - Bargman
50-67-409	7-Way Molded Trailer w/9 Ft. Cable and Breakaway Switch	Bulk
50-67-410	7-Way Molded Trailer w/10 Ft. Cable and Breakaway Switch	Bulk

Double Ended 7-Way Molded Trailer End with Cable

Part No.	Description	Packaging
50-67-901	Double Ended 7-Way Molded Trailer Cord w/6 Ft. Cable	Bulk
50-67-210	Double Ended 7-Way Molded Trailer Cord w/8 Ft. Cable	Bulk
51-67-210	Double Ended 7-Way Molded Trailer Cord w/8 Ft. Cable	Clam - Bargman

7-WAY COLD WEATHER MOLDED TRAILER END CONNECTORS WITH CABLE

7-way trailer connector molded to cold environment heavy duty blue silicon 7-way insulated cable (105°C - 55°C). Made with self-cleaning contacts and molded to encapsulate terminals and wires to form one weather resistant, non-corrosive assembly. Primary wire gauges within the insulated cable are: Black-White-Red-10 gauge, Blue-Brown-Green-Yellow-14 gauge. Molded connector can be used with thermo-plastic or metal 7-way car end connectors. Various length and combinations are available.

7-Way Cold Weather Molded Trailer End Connectors With Cable

Part No.	Description	Packaging
54006-009	7-Way Cold Weather Molded Trailer Cord w/6 Ft. Cable	Bulk
54006-010	7-Way Cold Weather Molded Trailer Cord w/8 Ft. Cable	Bulk





118664

6-WAY / 7-WAY TRAILER EXTENSION

- Durable connectors
- 7 ft. lead reaches almost anywhere

Part No.	Description	Packaging
118666	6-Way Connector - extension cable 7'	Bagged
118664	7-Way Connector - extension cable 7'	Bagged



7-WAY MOLDED TRAILER END CONNECTOR REPLACEMENT KIT

Easy to install, complete with instructions. Features self cleaning contacts, one foot of cable, butt connectors and weather resistant shrink tubing.

7-Way Molded Trailer End with Cable

Part No.	Description	Packaging
54-67-525	7-Way Molded Trailer End Connector Replacement Kit w/1 Ft. Cable	Bagged - Bargman



90° 7-WAY PRE-WIRED CABLES FOR HOOK-UP OF FIFTH WHEEL AND GOOSENECK TRAILERS

7-way 90° connector molded to heavy duty 7-way insulated cable for fifth wheel or gooseneck trailer applications. Allows remote wiring in pickup beds or other hard to access areas. 90° molded from flame retardant material. Features a patented mounted bracket that allows for installation in virtually all pickup models and styles and includes self-tapping stainless steel mounting screws. Manufactured with UL listed 10/2, 12/1 and 14/4 jacketed cable.

Part No.	Description	Packaging
50-97-407	90° 7-Way Molded Trailer Cord w/7 Ft. Cable	Bulk
51-97-407	90° 7-Way Molded Trailer Cord w/7 Ft. Cable	Clam - Bargman

VEHICLE SPECIFIC COMPLETE KITS



Part No.	Description	Packaging
50-97-410	90° 7-Way Complete Connector Kit w/9 Ft. Cable	Bulk
51-97-410	90° 7-Way Complete Connector Kit w/9 Ft. Cable	Box - Bargman
50-97-411	90° 7-Way Complete Connector Kit w/9 Ft. Cable	Bulk
51-97-411	90° 7-Way Complete Connector Kit w/9 Ft. Cable	Box - Bargman
50-97-412	90° 7-Way Complete Connector Kit w/9 Ft. Cable	Bulk
51-97-412	90° 7-Way Complete Connector Kit w/9 Ft. Cable	Box - Bargman
54700-003	90° 7-Way Complete Connector Kit w/7 Ft. Cable	Bulk
54701-003	90° 7-Way Complete Connector Kit w/7 Ft. Cable	Box - Bargman
54700-004	90° 7-Way Complete Connector Kit w/7 Ft. Cable	Bulk
54701-004	90° 7-Way Complete Connector Kit w/7 Ft. Cable	Box - Bargman

SEE APPLICATION CHART ON FOLLOWING PAGE FOR VEHICLE SPECIFIC APPLICATIONS.



U.S. CAR 7-WAY PRE-WIRED CABLES FOR HOOK-UP OF FIFTH WHEEL AND GOOSENECK TRAILERS



Allows remote wiring in pickup beds or other hard to access areas when towing a fifth wheel or gooseneck trailer, using an OEM U.S. CAR connector. Features durable plastic housing with weather tight seal.

Part No.	Description	Packaging
20224	U.S. Car 7-Way Connector w/4 Ft. Cable	Clam - Tow Ready
20223	U.S. Car 7-Way Connector w/7 Ft. Cable	Clam - Tow Ready



VEHICLE SPECIFIC COMPLETE KITS



Part No.	Description	Packaging
20110	U.S. Car 7-Way Complete Connector Kit w/7 Ft. Cable	Clam - Tow Ready
20111	U.S. Car 7-Way Complete Connector Kit w/7 Ft. Cable	Clam - Tow Ready
20113	U.S. Car 7-Way Complete Connector Kit w/7 Ft. Cable	Clam - Tow Ready
20128	U.S. Car 7-Way Complete Connector Kit w/7 Ft. Cable	Clam - Tow Ready
20129	U.S. Car 7-Way Complete Connector Kit w/7 Ft. Cable	Clam - Tow Ready
20130	U.S. Car 7-Way Complete Connector Kit w/7 Ft. Cable	Clam - Tow Ready
20131	U.S. Car 7-Way Complete Connector Kit w/7 Ft. Cable	Clam - Tow Ready
20140	Fifth Wheel Adapter Harness	Clam - Tow Ready

7-WAY 90° / PRE-WIRED CABLE APPLICATION CHART



MODEL	YEAR	POS	7Ft. CLAM	90°/9Ft. BOXED	90°/9Ft. BULK	90°/7Ft. BOXED	90°/7Ft. BULK
CHEVROLET/GMC							
Pickup, Sierra Classic w/Factory 7-Way	07	PU3	20110	51-97-410	50-97-410	54701-003	54700-003
		PU3	20140 ³				
Pickup, Sierra New Body Style	07-12	PU3	20110	51-97-410	50-97-410	54701-003	54700-003
		PU3	20140 ³				
Pickup, Sierra w/Factory 7-Way	99-06	PU3	20110	51-97-410	50-97-410	54701-003	54700-003
		PU3	20140 ³				
Pickup, Silverado Classic w/Factory 7-Way	07	PU3	20110	51-97-410	50-97-410	54701-003	54700-003
		PU3	20140 ³				
Pickup, Silverado New Body Style	07-12	PU3	20110	51-97-410	50-97-410	54701-003	54700-003
		PU3	20140 ³				
Pickup, Silverado w/Factory 7-Way	99-06	PU3	20110	51-97-410	50-97-410	54701-003	54700-003
		PU3	20140 ³				
DODGE							
Pickup, Ram, Full Size 1500 Only w/Factory 7-Way	00-08	PU3	20111	51-97-411	50-97-411		
Pickup, Ram, Full Size 1500 Only w/Factory 7-Way	09-12	PU3	20110	51-97-410	50-97-410	54701-003	54700-003
		PU3	20140 ³				
Pickup, Ram, Full Size 2500 HD Only w/Factory 7-Way	00-09	PU3	20111	51-97-411	50-97-411		
Pickup, Ram, Full Size 2500 HD Only w/Factory 7-Way	10-11	PU3	20110	51-97-410	50-97-410	54701-003	54700-003
		PU3	20140 ³				
Pickup, Ram, Full Size 3500 HD Only w/Factory 7-Way	00-09	PU3	20111	51-97-411	50-97-411		
Pickup, Ram, Full Size 3500 HD Only w/Factory 7-Way	10-11	PU3	20110	51-97-410	50-97-410	54701-003	54700-003
		PU3	20140 ³				
FORD							
F-150 Flareside (New Body Style) w/Factory 7-Way	04-11	PU3	20110	51-97-410	50-97-410	54701-003	54700-003
		PU3	20140 ³				
F-150 Styleside (New Body Style) w/Factory 7-Way	04-11	PU3	20110	51-97-410	50-97-410	54701-003	54700-003
		PU3	20140 ³				
F-150 Light Duty Flareside w/Factory 4-Flat	97-03	PU1,2	20128 ¹				
		PU1,2	20130 ²				
F-150 Light Duty Flareside w/Factory 7-Way	97-03	PU3	20110	51-97-410	50-97-410	54701-003	54700-003
		PU3	20140 ³				
F-150 Light Duty Styleside w/Factory 4-Flat	97-03	PU1,2	20128 ¹				
		PU1,2	20130 ²				
F-150 Light Duty Styleside w/Factory 7-Way	97-03	PU3	20110	51-97-410	50-97-410	54701-003	54700-003
		PU3	20140 ³				
F-150 Light Duty Heritage (Old Body Style) w/Factory 4-Flat	04	PU1,2	20128 ¹				
		PU1,2	20130 ²				
F-150 Light Duty Heritage (Old Body Style) w/Factory 7-Way	04	PU3	20110	51-97-410	50-97-410	54701-003	54700-003
		PU3	20140 ³				
F-150 SuperCrew New Body Style w/Factory 7-Way	04-11	PU3	20110	51-97-410	50-97-410	54701-003	54700-003
		PU3	20140 ³				
F-250 Light Duty Styleside w/Factory 4-Flat	97-99	PU1,2	20128 ¹				
		PU1,2	20130 ²				
F-250 Light Duty Styleside w/Factory 7-Way	97-99	PU3	20110	51-97-410	50-97-410	54701-003	54700-003
		PU3	20140 ³				
F-250 Super Duty w/Factory 4-Flat	99-01	PU1,2	20129 ¹				
		PU1,2	20131 ²				
F-250 Super Duty w/Factory 7-Way	99-12	PU3	20110	51-97-410	50-97-410	54701-003	54700-003
		PU3	20140 ³				
F-350 Super Duty w/Factory 4-Flat	99-01	PU1,2	20129 ¹				
		PU1,2	20131 ²				
F-350 Super Duty w/Factory 7-Way	99-12	PU3	20110	51-97-410	50-97-410	54701-003	54700-003
		PU3	20140 ³				

**7-WAY 90° / PRE-WIRED CABLE
APPLICATION CHART**



MODEL	YEAR	POS	7Ft. CLAM	90°/9Ft. BOXED	90°/9Ft. BULK	90°/7Ft. BOXED	90°/7Ft. BULK
FORD (Continued)							
F-450 Super Duty w/Factory 4-Flat	99-01	PU1,2	20129 ¹ 20131 ²				
F-450 Super Duty w/Factory 7-Way	99-12	PU3	20110 20140 ³	51-97-410	50-97-410	54701-003	54700-003
F-550 Super Duty w/Factory 4-Flat	99-01	PU1,2	20129 ¹ 20131 ²				
F-550 Super Duty w/Factory 7-Way	99-11	PU3	20110 20140 ³	51-97-410	50-97-410	54701-003	54700-003
LINCOLN							
Mark LT w/Factory 7-Way	06-08	PU3	20110 20140 ³	51-97-410	50-97-410	54701-003	54700-003
NISSAN							
Titan Pickup w/Factory 7-Way	04-11	PU3	20110 20140 ³	51-97-410	50-97-410	54701-003	54700-003
TOYOTA							
Tundra w/Factory 7-Way	07-09	PU3	20113	51-97-412	50-97-412	54701-004	54700-004
Tundra w/Factory 7-Way	10-12	PU3	20110 20140 ³	51-97-410	50-97-410	54701-003	54700-003

1- upgrades from O.E.M. 4-Flat to 6-Way wiring, 2- upgrades from O.E.M. 4-Flat to 7-Way wiring, 3- Pigtails for Choice of Hardwiring 6 or 7-Way Connector



7-WAY ROUND PIN AG CONNECTORS

A discrete round pin 7-way vehicle and implement connector for AG OEM and aftermarket use. Vehicle side connector includes a mountable storage box. Implement side connector includes a metal spring cable relief



Part No.	Description	Packaging
787305	7-Way Round Pin AG Vehicle Connector	Bulk
787303	7-Way Round Pin AG Vehicle Connector	Clam - Wesbar
787304	7-Way Round Pin AG Trailer Connector	Bulk
787302	7-Way Round Pin AG Trailer Connector	Clam - Wesbar

7-WAY MOLDED TRAILER CONNECTORS WITH CABLE - TRAILER CLOCKING



7-way plastic connector molded to heavy duty 7-way insulated cable using trailer clocking*. Provides 7-way connector contact color coding more conducive to horse and livestock trailers verses RV trailers. Made with self-cleaning contacts and molded to encapsulate terminals and wires to form one weather resistant, non-corrosive assembly. Permits the trailer to have the clean appearance and environmental advantages of a sealed, molded 7-way cord. Primary wire gauges within the insulated cable are: Black and White-10 gauge, Blue-12 gauge, Brown-Red-Green-Yellow-14 gauge.



Note: Various length and combinations available. Crimped junction box terminals can be added. Contact your Cequent Performance Products Representative for details.

Part No.	Description	Packaging
50-67-614	7-Way Molded Trailer Cord w/4' Cable	Bulk
50-67-616	7-Way Molded Trailer Cord w/6' Cable	Bulk
50-67-618	7-Way Molded Trailer Cord w/8' Cable	Bulk
50-67-620	7-Way Molded Trailer Cord w/10' Cable	Bulk

*NOTE: Reference Wiring Diagrams for pin locations.

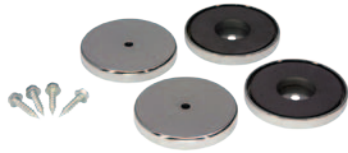

MAGNET KIT

Use of this magnet kit allows for temporary installation of single or dual lights. Set of four with hardware.

Part No.	Description	Packaging
002590	Magnet Kit, 90 lb. Pull	Bulk



TANDEM HAUL ADAPTER

The Tandem Haul Adapter allows implements to be towed in tandem, providing versatility and economy.

Part No.	Description	Packaging
002500	Tandem Haul Adapter	Bulk
002625	Tandem Haul Kit	Bulk

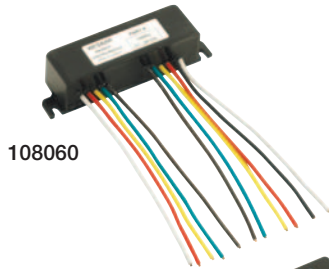

AG LIGHT ENHANCED LIGHTING MODULES

Install to meet the enhanced lighting standard and have a dramatic safety feature to better signal turns by tractors and implements. Contact your Cequent Representative for additional information.

Part No.	Description	Packaging
108060	Module w/Wire Leads	Bulk
108318	Module w/Molded Plugs	Bulk
108319	Module w/Weatherproof Plugs	Bulk
109992	Module w/Brake Light Signal Function w/Wire Leads	Bulk

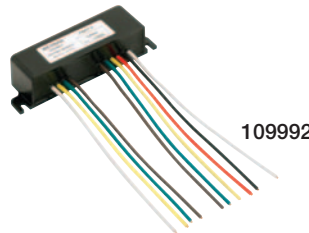
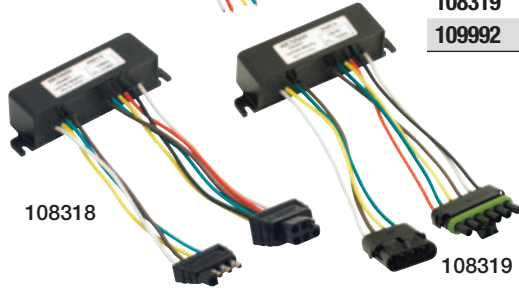

AG EXTENSION HARNESSSES

Install on towable field implements to bring power from the tractor to AG Lights. Full length ground assures reliable and continuous operation. Custom configurations and lengths available.

Part No.	Description	Packaging
002510	10' Heavy-Duty Wishbone Harness	Bulk
002408	5' Economy Extension Harness	Bulk
002410	10' Economy Extension Harness	Bulk
002415	15' Straight Section Harness w/7-Pin AG Plug and Flat 4-Way	Bulk
002425	25' Straight Section Harness w/7-Pin AG Plug and Flat 4-Way	Bulk
002430	30' Straight Section Harness w/7-Pin AG Plug and Flat 4-Way	Bulk
002504	10' Economy Rear Wishbone Harness	Bulk
002505	15' Economy Rear Wishbone Harness	Bulk
002515	15' Heavy-Duty Rear Wishbone Harness	Bulk



New**Wesbar.****LED HEAVY-DUTY AG LIGHTS**

Available in single and dual units, these lights meet all ASABE S279.15 lighting requirements including 4cp to side on amber lens. Dual lights designed for right hand and left hand vertical mounting. Rugged external housing and lens design. Same mounting foot print hardware and electrical connections as incandescent equivalent. Brake functions wired with SQ-4 plug.

6" x 5 1/2" x 3", 10 1/2" x 5 1/2" x 3"

Part No.	Description	Packaging
54209-010	Single LED AG Light w/Red/Black	Bulk
54209-012	Single LED AG Light w/Amber/Amber	Bulk
54209-006	Dual LED AG Light w/Amber/Red	Bulk
54209-020	Dual LED AG Light w/Red/Amber	Bulk
54209-008	Dual LED AG Light w/Amber/Red w/Brake Light Function	Bulk
54209-022	Dual LED AG Light w/Red/Amber w/Brake Light Function	Bulk

NOTE: Reference AG Lighting - Technical for mounting applications.

Note: Custom AG lighting and wiring kits are available. Contact your Cequent representative for requirements and minimum annual quantities.

LED ECONOMY AG LIGHT KIT

Featuring left hand and right hand dual light units, this kit include a 35 ft. wishbone wire harness, 7-pin AG plug and tri-plugs. For protection in critical areas, 5' of convoluted tubing is included.

New

Part No.	Description	Packaging
54003-040	Economy AG LED Light Kit	Bulk

Replacement Parts

54209-006	Dual LED AG Light w/Amber/Red	Bulk
54209-020	Dual LED AG Light w/Red/Amber	Bulk

US Patent D347,903/5,335,155

NOTE: Reference AG Lighting - Technical for mounting applications.

LED AG TRANSPORT LIGHT KITS

Featuring left and right hand dual light units with brake function, these kits include a 46 ft. round wishbone cable, 4 – 90 lb. magnets and a 7-pin round plug.

New

Part No.	Description	Packaging
54003-041	Deluxe AG LED Transport Kit w/Brake Light Function, 7-Pin	Bulk

Replacement Parts

54209-008	Dual LED AG Light w/Amber/Red w/Brake Light Function	Bulk
54209-022	Dual LED AG Light w/Red/Amber w/Brake Light Function	Bulk
002590	Magnet Kit, 90 lb. Pull	Bulk

US Patent D347,903/5,335,155

NOTE: Reference AG Lighting - Technical for mounting applications.



HEAVY-DUTY AG LIGHTS

Available in single and dual units, these lights meet all ASABE S279.13 lighting requirements including 4cp to side on amber lens. Dual lights designed for right hand-horizontal/vertical mounting or left hand-horizontal/vertical mounting. Rugged external housing and lens design with vibration dampening bulb holder. Brake functions wired with SQ-4 plug.

6" x 5 1/2" x 3", 10 1/2" x 5 1/2" x 3"

Part No.	Description	Packaging
8260501	Single AG Light w/Red/Black	Bulk
8260601	Single AG Light w/Amber/Amber	Bulk
8261001	Single AG Light w/Red/Black w/Brake Light Function	Bulk
8260001	Dual AG Light w/Amber/Red	Bulk
8260101	Dual AG Light w/Red/Amber	Bulk
8261501	Dual AG Light w/Amber/Red w/Brake Light Function	Bulk
8261601	Dual AG Light w/Red/Amber w/Brake Light Function	Bulk

Replacement Parts

30-90-157	Bulb #1157, Double Filament	Bulk
802650	Lens Amber, AG Lamp	Bulk
802651	Lens Red, AG Lamp	Bulk
802652	Insert Black, AG Lamp	Bulk

NOTE: Reference AG Lighting - Technical for mounting applications.



ECONOMY AG LIGHT KIT

Featuring left hand and right hand dual light units, this kit include a 35 ft. wishbone wire harness, 7-pin AG plug and tri-plugs. For protection in critical areas, 5' of convoluted tubing is included.

Part No.	Description	Packaging
002670	Economy AG Light Kit	Bulk

Replacement Parts

8260001	Dual AG Light w/Amber/Red	Bulk
8260101	Dual AG Light w/Red/Amber	Bulk

US Patent D347,903/5,335,155

NOTE: Reference AG Lighting - Technical for mounting applications.



AG TRANSPORT LIGHT KITS

Featuring left and right hand dual light units with brake function, these kits include a 46 ft. round wishbone cable, 4 – 90 lb. magnets and either a 7-pin or 6-pin round plug.

Part No.	Description	Packaging
002675	Deluxe AG Transport Kit w/Brake Light Function, 6-Pin	Bulk
002676	Deluxe AG Transport Kit w/Brake Light Function, 7-Pin	Bulk

Replacement Parts

8261501	Dual AG Light w/Amber/Red w/Brake Light Function	Bulk
8261601	Dual AG Light w/Red/Amber w/Brake Light Function	Bulk
002590	Magnet Kit, 90 lb. Pull	Bulk

US Patent D347,903/5,335,155

NOTE: Reference AG Lighting - Technical for mounting applications.

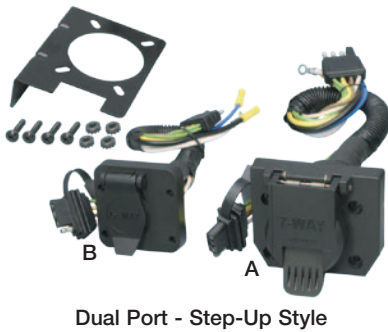
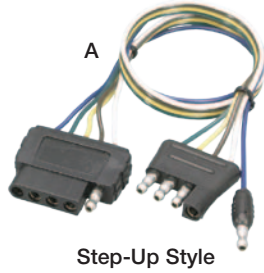

VEHICLE/TRAILER ADAPTERS

Adapters for a quick switch from one style plug to another when towing multiple trailers.

Standard Vehicle/Trailer Adapters - Step - Down Style

Part No.	Description	Packaging
50-98-054	6-Way Round Pin to 4-Way Flat (Photo A)	Bulk
707281	6-Way Round Pin to 4-Way Flat (Photo A)	Clam - Wesbar
50-98-050	7-Way Blade to 4-Way Flat (Photo B)	Bulk
54-98-050	7-Way Blade to 4-Way Flat (Photo B)	Bagged - Bargman
707282	7-Way Blade to 4-Way Flat (Photo B)	Clam - Wesbar
50-98-052	7-Way Round Pin to 4-Way Flat (Photo C)	Bulk
54-98-052	7-Way Round Pin to 4-Way Flat (Photo C)	Bagged - Bargman
51-30703	7-Way Blade to 5-Way Flat (Photo D)	Clam - Bargman
767940	7-Way Blade to 5-Way Flat (Photo D)	Clam - Wesbar
007257	7-Way Blade to 5-Way Flat, 6" Wire (Photo E)	Clam - Wesbar
707250	7-Way Blade to 5-Way Flat, 18" Wire (Photo F)	Clam - Wesbar
50-98-051	7-Way Blade to 6-Way Round Pin (Auxiliary in Center) (Photo G)	Bulk
54-98-051	7-Way Blade to 6-Way Round Pin (Auxiliary in Center) (Photo G)	Bagged - Bargman

Standard Vehicle/Trailer Adapters - Step - Up Style

Part No.	Description	Packaging
51-20036	4-Way Flat to 5-Way Flat (Photo A)	Clam - Bargman

Dual Port Vehicle/Trailer Adapters - Step - Up Style

Part No.	Description	Packaging
20144	4-Way Flat to 4-Way Flat and 7-Way Blade (Photo A)	Clam - Tow Ready
20143	4-Way Flat to 4-Way Flat and 6-Way Round (Photo B)	Clam - Tow Ready



VEHICLE/TRAILER COILED WIRE JUMPERS



Environmentally sealed 16 gauge coiled wire prevents tangling. Attractive marine yellow, no fade color. 7-Way mates with OE style 7-way blade connectors. 5-way mates with either a 4-way or 5-way flat connector.

5-WAY TO 5-WAY COILED WIRE JUMPER

Part No.	Description	Packaging
787206	5-Way Coiled Jumper w/4 Ft. Cable (5-Way Flat Car and Trailer Ends)	Bulk
787194	5-Way Coiled Jumper w/4 Ft. Cable (5-Way Flat Car and Trailer Ends)	Clam - Wesbar

7-WAY TO 5-WAY COILED WIRE JUMPERS

Part No.	Description	Packaging
787207	7-Way Trailer to 5-Way Flat Car End Coiled Jumper w/4 Ft. Cable	Bulk
787195	7-Way Trailer to 5-Way Flat Car End Coiled Jumper w/4 Ft. Cable	Clam - Wesbar
787208	7-Way Trailer to 5-Way Flat Car End Coiled Jumper w/8 Ft. Cable	Bulk
787196	7-Way Trailer to 5-Way Flat Car End Coiled Jumper w/8 Ft. Cable	Clam - Wesbar



4, 5, 6 AND 7-WAY ADAPTERS

- Allows convenient connection to multiple trailers
- Simple plug-in installation



Part No.	Description	Packaging
118700	6-Way Round Pin To 4-Flat Adapter	Clam - Tow Ready
118700-050	6-Way Round Pin To 4-Flat Adapter (50 Pack)	Boxed
118702	7-Way Flat Pin To 4-Flat Adapter	Clam - Tow Ready
118702-050	7-Way Flat Pin To 4-Flat Adapter (50 Pack)	Boxed
118709	7-Way Round Pin To 4-Flat Adapter	Clam - Tow Ready
118704	7-Way To 6-Way Adapter, Electric Brakes To Outer Pin (S)	Clam - Tow Ready
118704-050	7-Way To 6-Way Adapter, Electric Brakes To Outer Pin (S) (50 Pack)	Boxed
118708	7-Way To 6-Way Adapter, Electric Brakes To Center Pin (A)	Clam - Tow Ready
118708-050	7-Way To 6-Way Adapter, Electric Brakes To Center Pin (A) (50 Pack)	Boxed
118703	7-Way To 5-Flat Adapter	Clam - Tow Ready
20136	4-Flat To 5-Flat Adapter	Clam - Tow Ready
118032	4-Flat To 4-Flat Universal Adapter	Bagged
118601	4-Flat Knockout Adapter	Clam - Tow Ready

7-WAY TO CIGARETTE ADAPTER

- Provides 12v power at rear of vehicle for travel accessories
- Ideal for power inverter hook-up
- Great for tailgating



118019

Part No.	Description	Packaging
118019	7-Way to Cigarette Lighter Plug Adapter	Clam - Tow Ready



78007

7-WAY TO 4-WAY RETRACTABLE WIRING ADAPTER

- Converts 7-way round blade connector to standard 4-way flat connector
- Adjust length up to 42", no wires dragging on the ground
- Retractable 4-way flat car end plug connects with standard 4-way flat trailer end plug
- Adapts to factory 7-way blade receptacle
- Protects & stores when not in use



Plug & Play Installation

Part No.	Description	Packaging
78007	7-way round blade to 4-way flat	Open Plastic Shroud



78118

7-WAY BLADE TO 4-FLAT W/LED CIRCUIT TESTER

- Easily adapt OEM 7-way blade connector to either 5-flat or a 4-flat connector, Patent pending
- Instantly checks electrical circuit for connectivity
- Displays connectivity using high visibility Blue LEDs
- Attached dust cover included to keep terminals clean when not towing a trailer

Part No.	Description	Packaging
78118	7-Way Blade to 4 or 5-Flat w/LED Circuit Tester	Open Plastic Shroud



78117

7-WAY TO 4-WAY WITH TOW-GLO

- Easily adapt OEM 7-way blade connector to basic 4-flat connector
- Glows BLUE when tail light circuit is activated assisting on seeing connection at night-time
- Attached dust cover included to keep terminals clean when not towing a trailer

Part No.	Description	Packaging
78117	7-Way Blade to 4-Flat w/Tow-Glo	Open Plastic Shroud



20321



20125



118799



118607

6-WAY AND 7-WAY ELECTRICAL ADAPTERS

- Used to convert any trailer wiring component, T-One® or Taillight Converter with a 4-Flat Trailer End Connector to a 6 or 7-Way Round Connector
- For simple mounting, choose 6 & 7-Way Mounting Box Part Numbers 118156, 118157 or 118159 (sold separately)

Part No.	Description	Packaging
20320	4-Flat To 6-Way Round Pin Connector	Clam - Tow Ready
20320-012	4-Flat To 6-Way Round Pin Connector (12 Pack)	Bulk
20321	4-Flat To 7-Way Flat Pin Connector - Plastic	Clam - Tow Ready
20321-012	4-Flat To 7-Way Flat Pin Connector - Plastic (12 Pack)	Bulk
20322	4-Flat To 7-Way Flat Pin Connector - Metal	Clam - Tow Ready
20125	4-Flat To 7-Way Flat Pin U.S. Car Connector - Plastic	Clam - Tow Ready

7-WAY PRE-WIRED ADAPTERS

- Used to convert any trailer wiring component, T-One® or Taillight Converter with a 4-Flat Trailer End Connector to a 7-Way Round Connector. Each kit includes 20' of wire.
- For simple mounting, choose 7-Way Mounting Box Part Numbers 118156, 118157 or 118159 (sold separately)

Part No.	Description	Packaging
118799	7-Way Flat Pin Connector w/ Pre-wired Brake Wire	Clam - Tow Ready

BRAKE MATE™ KIT - 7-WAY PRE-WIRED ADAPTERS

Includes all necessary parts required to completely install all brake controls. No other parts are necessary. Each BRAKE MATE™ KIT includes:

- Pre-wired 7-way round connector
- Scotch locks (5 pcs.)
- 4-Flat trailer end
- Ring connectors (7 pcs.)
- Heavy-Duty flasher
- Self tapping screws (8 pcs.)
- Heavy-Duty breakers (2 pcs.)
- Tie straps (6 pcs.)
- For simple mounting, choose 7-Way Mounting Box Part Numbers 118156, 118157 or 118159 (sold separately)

Part No.	Description	Packaging
118607	7-Way Flat Pin Brake Mate™ Kit	Clam - Tow Ready

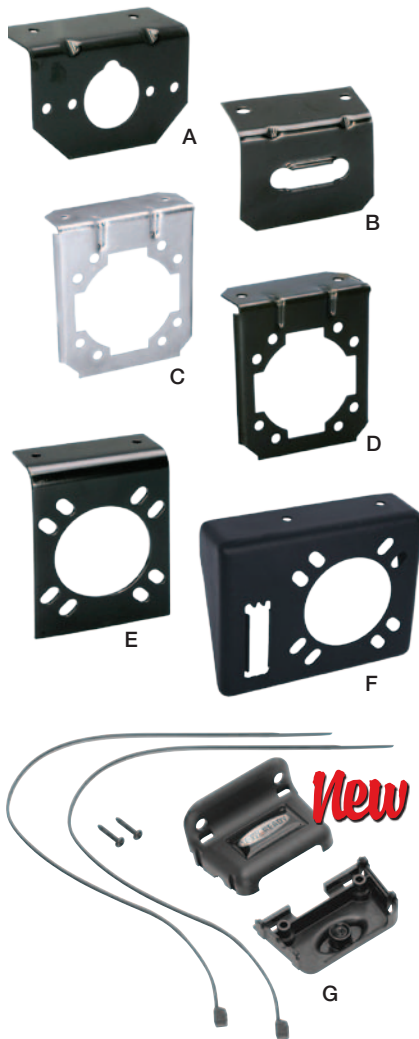

CAR END MOUNTING BRACKETS

Heavy duty plated steel brackets. Features reinforcing beads or flanges for strength. The Black plated model can blend in with the black connector and black hitch for clean consistent finish. Combination brackets have a black, powder coat finish and are formed from 16 gauge steel for strength and durability. Combination brackets are for use with Bargman and Wesbar branded 4-Way and 5-Way Flat connectors.

4-Way Flat Car End Connector Mounting Brackets

Part No.	Description	Packaging
54-18137	4, 5 and 6-Way Round Black Mounting Bracket w/Screws and Nuts (Photo A)	Bagged - Bargman
118149	4-Way Flat Universal Mounting Bracket (Photo G)	Clam - Tow Ready

5-Way Flat Car End Connector Mounting Bracket

Part No.	Description	Packaging
54-20045	5-Way Flat Black Mounting Bracket (Photo B)	Bagged - Bargman
54-18137	4, 5 and 6-Way Round Black Mounting Bracket w/Screws and Nuts (Photo A)	Bagged - Bargman

6-Way Car End Connector Mounting Brackets

Part No.	Description	Packaging
54-18137	4, 5 and 6-Way Round Black Mounting Bracket w/Screws and Nuts (Photo A)	Bagged - Bargman

7-Way Car End Connector Mounting Brackets

Part No.	Description	Packaging
50-77-070	7-Way Bracket for Car End (Photo C)	Bulk
50-77-071	7-Way Black Bracket for Car End (Photo D)	Bulk
54-77-071	7-Way Black Bracket for Car End (Photo D)	Bagged - Bargman
54-20012	7-Way US Car Black Mounting Bracket w/Screws and Nuts (Photo E)	Bagged - Bargman

Combination Connector Mounting Brackets

Part No.	Description	Packaging
50-77-074	7-Way and 4-Way Flat Mounting Bracket (Photo F)	Bulk
54-77-074	7-Way and 4-Way Flat Mounting Bracket (Photo F)	Bagged - Bargman
50-77-075	7-Way and 5-Way Flat Mounting Bracket (Photo F)	Bulk
54-77-075	7-Way and 5-Way Flat Mounting Bracket (Photo F)	Bagged - Bargman

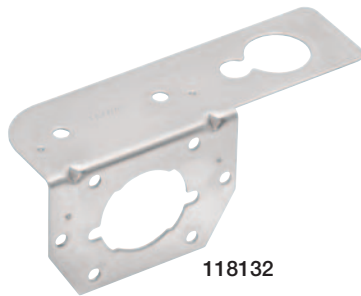

4-WAY AND 6-WAY MOUNTING BRACKET



Part No.	Description
118132	Mounting Bracket for 4 & 6-Way Round Connectors (does not include fasteners)

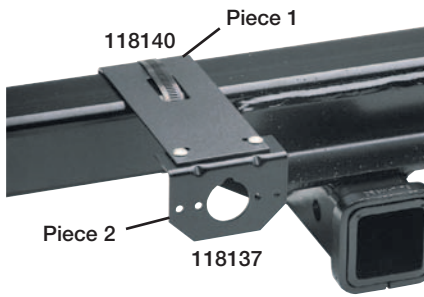

4, 5, 6 AND 7-WAY CONNECTOR MOUNTING BRACKETS

Tow Ready's line of mounting brackets allows for installation of electrical wiring plugs on vehicles without damage to bumpers or fascia trim. Attachment brackets are designed to attach above or below receiver cross tube with hose clamp.



ATTACHMENT BRACKETS (PIECE 1 OF 2)

- Attaches to cross tube of hitch

Part No.	Description	Packaging
118136	Attachment Bracket For 6 & 7-Way Round Connectors, Includes Clamp (Piece 1 Of 2, Long Bracket)	Clam - Tow Ready
118140	Attachment Bracket For 4-Flat, 5-Flat, 4-Way & 5-Way Round Connectors, Includes Clamp (Piece 1 Of 2, Short Bracket)	Clam - Tow Ready

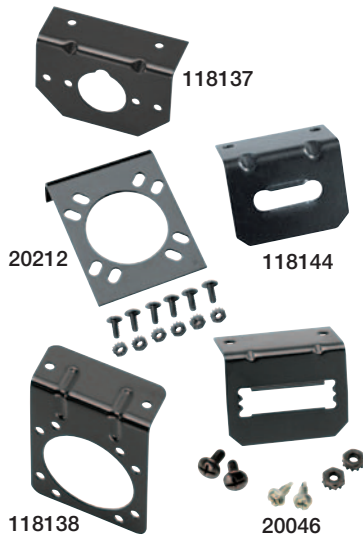

MOUNTING BRACKETS (PIECE 2 OF 2)

- Mounts electrical connector to attachment bracket
- Includes screws and nuts
- Attractive point-of-purchase packaging

Part No.	Description	Packaging
118137	Mounting Bracket For 4, 5 & 6-Way Round Connectors, (Piece 2 Of 2)	Clam - Tow Ready
118137-010	Mounting Bracket (10 Pack)	Bulk
118138	Mounting Bracket For 7-Way Standard Connectors, (Piece 2 Of 2)	Clam - Tow Ready
118138-010	Mounting Bracket (10 Pack)	Bulk
118144	Mounting Bracket For 4-Flat Connectors, (Piece 2 Of 2)	Clam - Tow Ready
118144-010	Mounting Bracket (10 Pack)	Bulk
20212	Mounting Bracket For 7-Way Us Car Connectors, (Piece 2 Of 2)	Clam - Tow Ready
20212-010	Mounting Bracket (10 Pack)	Bulk
20046	Mounting Bracket For 5-Flat Connectors, (Piece 2 Of 2)	Clam - Tow Ready



6-WAY AND 7-WAY PLUG HOLDER

This holder is designed to house your 6-way or 7-way trailer end connector safely out-of-the-way when disconnected from the tow car. Universal holder will accommodate either die cast, steel, plastic or molded trailer ends. Black molded plastic holder mounts on the jackpost with provided cable-ties or the attached adhesive strip and can be mounted on any flat surface with provided screws.

Part No.	Description	Packaging
54-98-003	6-Way and 7-Way Plug Holder	Bagged - Bargman



6-WAY AND 7-WAY CONNECTOR HOLDER



- Securely stores 6 and 7-Way Trailer Connectors when not in use
- Mount to tongue jack or trailer frame

Part No.	Description	Packaging
118152	6-Way and 7-Way Trailer Connector Holder	Bagged - Tow Ready



4-FLAT CONNECTOR STORAGE BOX & COVERS



- Neatly stores 4-Flat and 5-Flat connectors
- Easily installs with cable ties or screws (included)
- Weatherproof construction

Part No.	Description	Packaging
118145	Connector Storage Box	Clam - Tow Ready



6-WAY AND 7-WAY CONNECTOR MOUNTING BOXES

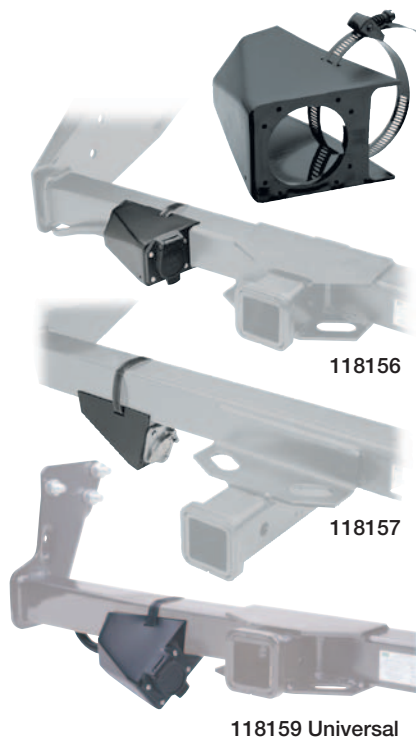

- No need to disconnect existing wiring
- No drilling
- Mounts with hose clamp included
- Corrosion free
- High impact plastic
- Fits all standard & U.S. car 7-way connectors

Part No.	Description	Packaging
118156	6-Way and 7-Way Connector Mounting Box For Hitches w/2-1/2" Sq. Cross Tubes	Display Box - Tow Ready
118156-010	6-Way and 7-Way Connector Mounting Box (10 Pack)	Boxed
118157	6-Way and 7-Way Connector Mounting Box For Hitches w/3" Sq. Cross Tubes	Display Box - Tow Ready
118157-010	6-Way and 7-Way Connector Mounting Box (10 Pack)	Boxed
118159	6-Way and 7-Way Connector Mounting Box With Universal Fit For Both Square And Round Tube Hitches	Display Box - Tow Ready
118159-010	6-Way and 7-Way Connector Mounting Box (10 Pack)	Boxed



JUNCTION / BREAKER BOXES



Provide a fast, simplified way of connecting wires from the trailer connector to the trailer wiring. The box comes complete with hardware rubber grommets, and features external mounting flanges.

Dimensions: 3 1/4" x 6 1/2" x 2 1/4"

Part No.	Description	Packaging
14-715810	Junction Box	Bulk
787535	Junction Box	Bagged - Bargman
54501-002	Breaker Box	Bulk

Note: Most Bargman® 7-way cable products meet UL standards and are appropriately marked. If a non-UL listed cable will be used to connect tow vehicles to trailers capable of housing or transporting live occupants, Cequent Performance Products recommends the use of a wiring Junction Box. This will provide a simplified method of connecting wire leads from the trailer connector to the UL listed trailer wiring.



**TOW VEHICLE WIRING COMPONENTS
HEAVY DUTY FLASHERS & RELAYS**



Part No.	Description	Packaging
39552	Heavy-Duty 552 Flasher	Clam - Tow Ready
39552-012	Heavy-Duty 552 Flasher (12 pack)	Bulk
38659-010	SPDT 5 Terminal Micro Relay, 12 Volt, 30 Amp, 1997-Up Ford F-150/F-250 (10 pack)	Bulk
38660-010	SPDT 5 Terminal Relay, 14 Volt, 20 Amp, 1999-Up Ford F-250/F-350 (10 pack)	Bulk
38665-012	4 Terminal Relay, 12 Volt, 2007-Up Chevrolet Equinox, Pontiac Torrent & Suzuki XL-7/2008-Up Ford Escape, Mazda Tribute & Mercury Mariner (12-pack)	Bagged

PRIMARY WIRE



Part No.	Description	Packaging
18035	500' 18 gauge, 4 conductor, bonded wire (1 spool)	Spool
38269	500' 16 gauge, green (1 spool)	Spool
38272	500' 16 gauge, brown (1 spool)	Spool
38270	500' 16 gauge, yellow (1 spool)	Spool
38271	500' 16 gauge, white (1 spool)	Spool
38210	100' 14 gauge, 6 trailer wires (1 spool)	Spool
38265	500' 14 gauge, white (1 spool)	Spool
38266	500' 14 gauge, blue (1 spool)	Spool
38267	500' 14 gauge, red (1 spool)	Spool
38268	500' 14 gauge, black (1 spool)	Spool
38250	500' 12-2, duplex wire, black & blue (1 spool)	Spool
38262	500' 12 gauge, white (1 spool)	Spool
38263	500' 12 gauge, black (1 spool)	Spool
38264	500' 12 gauge, blue (1 spool)	Spool
18191	250' 12 gauge, 7 conductor, jacketed wire - white, black & blue, 14 gauge yellow, brown, green & red (1 spool)	Spool
38279	500' 10 gauge, black (1 spool)	Spool

FUSES & FUSE HOLDERS

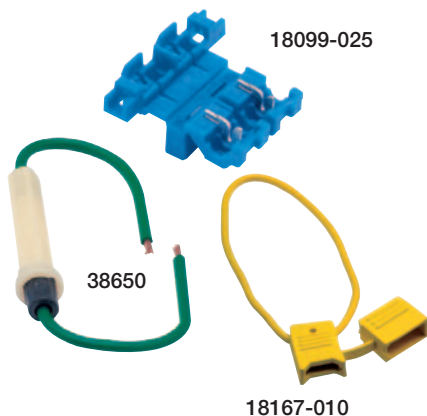

Part No.	Description	Packaging
18099-025	In-line Fuse Holder wire taps (self-stripping) for use w/32v maximum - 20 amp maximum bayonet type fuses & 14 to 18 gauge wire (25 pack)	Bagged
18167-010	20 amp. Fuse Holder with protective cover (10 pack)	Bagged
20006-010	30 amp. Maxi-Fuse®* (10 pack)	Bagged
38650	In-line Fuse Holder w/20 amp fuse	Clam - Tow Ready
38654	40 amp. Maxi-Fuse®*	Clam - Tow Ready
38661-010	Fuse Line, 32 volt, 30 amp, 98-up Dodge (10 pack)	Bulk

* Maxi-fuse® / Slo-Blo® brand or comparable substitute

WIRE CONDUIT



Part No.	Description	Packaging
29522	3/8" Conduit - 50 foot coil in a bag (1 spool)	Spool
29523	1/2" Conduit - 50 foot coil in a bag (1 spool)	Spool



UNIVERSAL BATTERY CONNECTORS

Part No.	Description	Packaging
118630	Side Post, 1-3/4" Short Side Terminal	Clam - Tow Ready
118631	Side Post, 1-3/16" Long Side Terminal	Clam - Tow Ready
118634	Tap/Ground Kit, Side Mount With 22-16 Gauge Terminals	Clam - Tow Ready

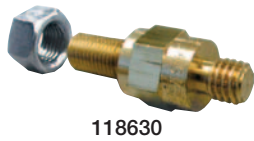

HARDWARE COMPONENTS

Assortment of hardware components designed specifically for the trailer industry.

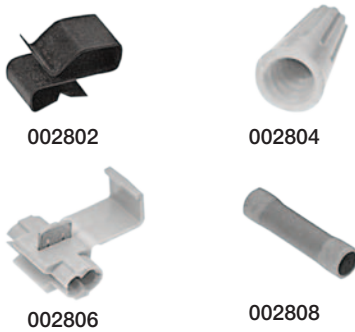

Part No.	Description	Packaging
104429	Clip, Plastic Wire, Adhesive Back	Bulk
002802	Clip, Metal Wire	Bulk
002804	Nut, Wire (Small, 16-18 gauge)	Bulk
002805	Nut, Wire (Large, 14-16 gauge)	Bulk
002806	Tap, White Wire, Double Leads	Bulk
002807	Tap, Blue Wire, Single Leads	Bulk
002808	Butt Connector, Blue (14-16 gauge)	Bulk



TERMINALS AND CONNECTORS

Part No.	Description	Packaging
38330-100	Butt Connectors, 14-16 gauge wire, blue (100 pack)	Bulk
38332-100	Butt Connectors, 10-12 gauge wire, yellow (100 pack)	Bulk
18121-100	Ring Terminal, 10-12 gauge wire, 3/16" stud (100 pack)	Boxed
38335-100	Ring Terminal, 10-12 gauge wire, 5/16" stud (100 pack)	Bulk
38331-100	Insulated Ring Terminal, 14-16 gauge wire, #10 stud (3/16") (100 pack)	Bulk
38337-100	Insulated Ring Terminal, 10-12 gauge wire, #10 stud (3/16") (100 pack)	Bulk
38338-100	Insulated Ring Terminal, 10-12 gauge wire, 1/4" stud (100 pack)	Bulk
38339-100	Insulated Ring Terminal, 10-12 gauge wire, 3/8" stud (100 pack)	Bulk
38341-100	Fully Insulated Disconnect, female, 14-16 gauge wire (100 pack)	Bulk
18164-020	1/4" Diameter Shrink Tube, 8" length (20 pack)	Bagged
20034-025	Perm-A-Seal® Butt Connectors, 14-16 gauge, blue (25 pack)	Bagged
20035-025	Perm-A-Seal® Butt Connectors, 10-12 gauge, yellow (25 pack)	Bagged

* Perm-A-Seal® brand or comparable substitute

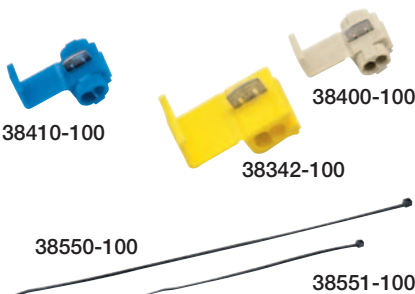

BULK WIRE TAPS & TIES

Part No.	Description	Packaging
38400-100	Wire Taps, 14 to 18 gauge wire (3m 564) white (100 pack)	Bulk
38342-100	Wire Taps, 10 to 12 gauge wire (3m 562) yellow (100 pack)	Bulk
38410-100	Wire Taps, 14 to 18 gauge wire (3m 801) blue (100 pack)	Bulk
38550-100	14-1/2" All Weather Cable Ties, black (100 pack)	Bulk
38551-100	8" All Weather Cable Ties, black (100 pack)	Bulk
05102-100	6-5/8" All Weather Beaded Cable Ties, white (100 pack)	Bagged

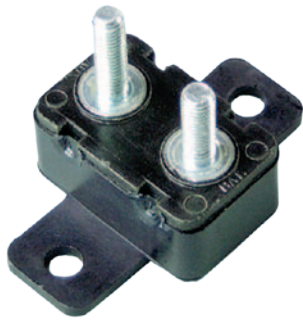

CIRCUIT BREAKERS



Used in 6, 12 and 24V DC applications. Automotive, R.V., air conditioners, battery chargers, any application requiring over-current protection. Non-corrosive molded cover eliminates grounding when operating against a fault line. Includes mounting bracket and installed nuts and washers.

Part No.	Description	Packaging
7010A	15 Amp Circuit Breaker	Bulk
7011A	20 Amp Circuit Breaker	Bulk
7012A	30 Amp Circuit Breaker	Bulk
7013A	40 Amp Circuit Breaker	Bulk
7022A	50 Amp Circuit Breaker	Bulk
7010A-S	15 Amp Circuit Breaker	Clam - Tekonsha
7011A-S	20 Amp Circuit Breaker	Clam - Tekonsha
7012A-S	30 Amp Circuit Breaker	Clam - Tekonsha
7013A-S	40 Amp Circuit Breaker	Clam - Tekonsha
7022A-S	50 Amp Circuit Breaker	Clam - Tekonsha



38620, 38630, 38640

CIRCUIT BREAKERS



Part No.	Description	Packaging
38620	20 amp. In-line Circuit Breaker w/bracket	Clam - Tow Ready
38620-010	20 amp. In-line Circuit Breakers w/brackets (10 pack)	Bagged
38630	30 amp. In-line Circuit Breaker w/bracket	Clam - Tow Ready
38630-010	30 amp. In-line Circuit Breakers w/brackets (10 pack)	Bagged
38640	40 amp. In-line Circuit Breaker w/bracket	Clam - Tow Ready
38640-010	40 amp. In-line Circuit Breakers w/brackets (10 pack)	Bagged



7200

ELECTROTEK® NON-CONDUCTIVE DIELECTRIC SILICONE COMPOUND



ElectroTek® is to be used for all electrical connections, where a dielectric compound is required to prevent voltage loss from arcing and to protect contacts from corrosion. Suppresses radio frequency interference, dissipates heat, insulates trailer wiring connectors and seals out moisture. Effective for automotive, RV and marine electrical applications. Non-water soluble. 3 oz. tube.

Part No.	Description	Packaging
7200	ElectroTek	Bulk
7200P	ElectroTek	Clam - Tekonsha



11755

DIELECTRIC GREASE



Using dielectric grease on electrical connectors helps prevent corrosion and increases reliability.

Part No.	Description	Packaging
11755	Dielectric Grease, 2 oz. tube	Boxed - Tow Ready

AG LIGHTING



TECHNICAL INFORMATION IS CURRENT AS OF THE PRINTING OF THIS CATALOG. CONTACT TECHNICAL SERVICE FOR PERIODIC UPDATES.

AG LIGHTS

Meet lighting standards for agricultural field equipment and improve high-way operating safety easily and cost effectively with AG Lights by Cequent™. No other lighting package offers you the quality and dependability of AG Lights by Cequent. Designed specifically for the agricultural industry, AG Lights by Cequent withstand the most rigorous field and environmental conditions for long life and wear without repair. A variety of mounts enable easy and quick placement on all towable field equipment – harvesters, field cultivators, tillage equipment, forage boxes, and more.

SAFETY IS KEY

Meet ASAE lighting recommendations for agricultural equipment and improve safety, while operating on highways easily and cost effectively, with AG Lights by Cequent. No other lighting package offers you the quality, durability, and reliability of AG Lights by Cequent. Designed specifically for the agricultural industry, these Heavy-Duty AG Lights, when combined with Cequent's AG Wiring, withstand the most rigorous field and environmental conditions for long life and wear.

DURABLE, DEPENDABLE CONSTRUCTION OF HEAVY-DUTY AG LIGHTS

- High-impact, glass-filled thermoplastic housings deflect objects away from the lens area and prevent them from damaging or dislodging the lights assembly.
- Acrylic lenses.
- All fasteners provided are coated to resist rust.
- Bulb replacement, if ever needed, is simple – uses readily available standard automotive #1157 bulbs.

USER-FRIENDLY DESIGN

- AG Harnesses are designed with a full-length ground circuit, from tractor to AG Lamp, assuring reliable and continuous operation.
- Each light's wiring is routed through a center port area, helping facilitate a variety of light placement.
- AG Lights by Cequent are available with a variety of connector options.
- Mount lights vertically or horizontally. Choose from mounting screws, bolts, or heavy-duty magnets to meet your mounting needs.

- All lighting units are designed for easy customer repairs... right in the field. Pry out lenses with flat screwdriver for easy access to, and replacement of, the #1157 bulb.
- Five distinctly different light styles to meet your performance and styling requirements.

ELECTRONIC ENHANCED AG LIGHTING MODULE

Cequent, known for innovation and product reliability, presents an electronic module to deliver the ASAE recommended "enhanced turn signal lighting" with conventional AG lights and a standard wiring scheme. This unit may be hard-wired into the AG lighting harness or coupled-in by use of a variety of plug assemblies.

Use of Cequent's electronic enhanced AG lighting module helps to meet the new ASAE standard cost effectively. It eliminates the need for special wedge-based bulbs and non-standard wire schemes to deliver the enhanced turn signal lighting called for by this ASAE standard.

Refer to the Standard AG Implement Enhanced Lighting Guide.

MULTIPLE MOUNTING OPTIONS

A variety of mounts enable suitable placement on tractors and all towable field equipment – harvesters, cultivators, tillage equipment, fertilizers, forage boxes, and more. Heavy-Duty AG Lights by Cequent have a patented design incorporating multiple mounting options and lighting combinations. Dual AG Light models provide amber flashing and turn indicators plus red tail light functions. Amber or red single lights provide maximum mount flexibility (vertically or horizontally) to meet applicable lighting requirements. All AG Lights by Cequent, except the grommated series, are equipped with an exclusive molded weather-resistant low profile tri-plug. Custom plug configurations are also available.

Additionally, an optional brake light function is available for dual light or single red-lensed models. This optional function is also needed on lights used with enhanced turn light systems. The brake light option is recommended when implements are to be towed by non-farm vehicles or tractors with brakes (brake lights).

AG SAFETY LIGHTING SYSTEMS: Variety of Mounts and Uses

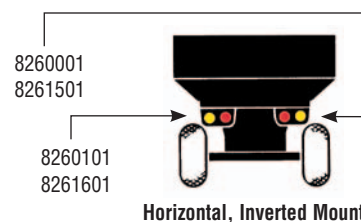
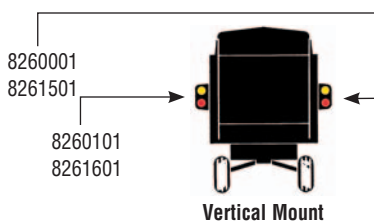
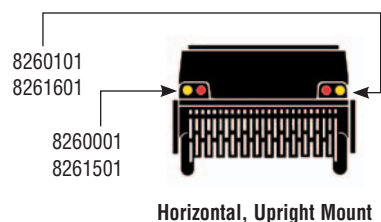

STANDARD AG IMPLEMENT ENHANCED LIGHTING SCHEME

Under both the standard and enhanced lighting schemes, when traveling straight forward, the amber (outside) lights flash in unison with the tractor's amber lights on the high intensity at approximately 100 pulses per minute, and the low intensity of the red (inside) lights are on constantly.

With the standard wire harness in place, when a turn is being signaled, the amber light signaling the turn will increase flashing to approximately 120 pulses per minute with the amber light on the opposite side changing to a constant high intensity light. This mirrors the amber light on the tractor. Both red lights, however, remain on a constant low intensity.

To meet the enhanced lighting standard, introduce Electronic AG Light Enhanced Module to the implement's wire harness, and simply add red lights that have an active high intensity along with an additional RH and LH wire to these red lights. With this enhanced AG lighting system, during a turn the red light next to the amber turn side light will rapidly flash on the high intensity in unison with the amber light, and the red light on the opposite side will remain constant on the high intensity. This is a dramatic safety feature to better signal (to everyone) turns by tractors and implements.

AG LIGHTING WIRING DIAGRAM

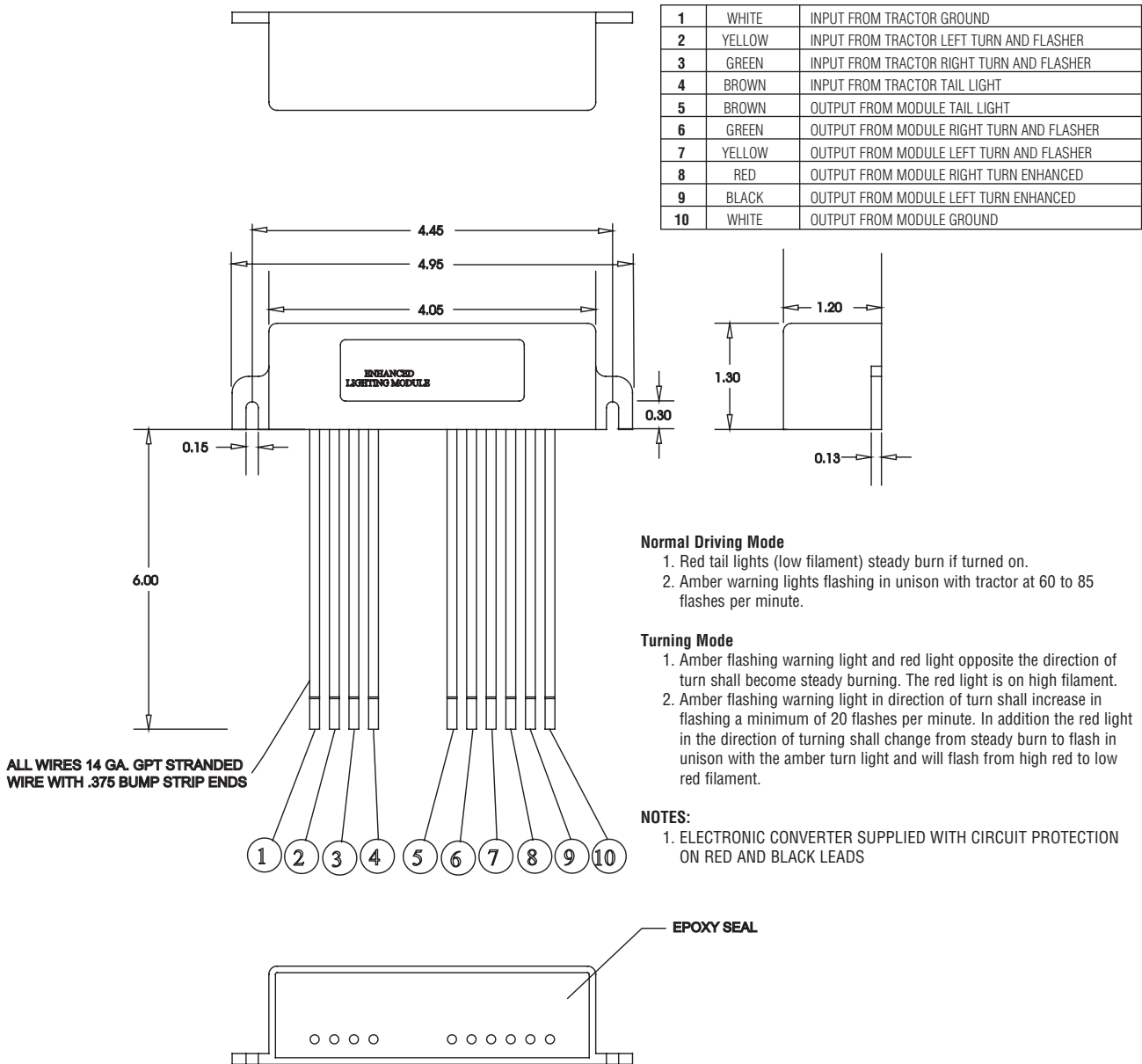

ALL WIRES 14 GA. GPT STRANDED WIRE WITH .375 BUMP STRIP ENDS

EPOXY SEAL

AG LIGHTING WIRING DIAGRAM WITH BRAKE

1	WHITE	INPUT FROM TRACTOR GROUND
2	RED	INPUT FROM TRACTOR BRAKE SIGNAL
3	YELLOW	INPUT FROM TRACTOR LEFT TURN AND FLASHER
4	GREEN	INPUT FROM TRACTOR RIGHT TURN AND FLASHER
5	BROWN	INPUT FROM TRACTOR TAIL LIGHT
6	BROWN	OUTPUT FROM MODULE TAIL LIGHT
7	GREEN	OUTPUT FROM MODULE RIGHT TURN AND FLASHER
8	YELLOW	OUTPUT FROM MODULE LEFT TURN AND FLASHER
9	RED	OUTPUT FROM MODULE RIGHT TURN ENHANCED & BRAKE SIGNAL
10	BLACK	OUTPUT FROM MODULE LEFT TURN ENHANCED & BRAKE SIGNAL
11	WHITE	OUTPUT FROM MODULE GROUND

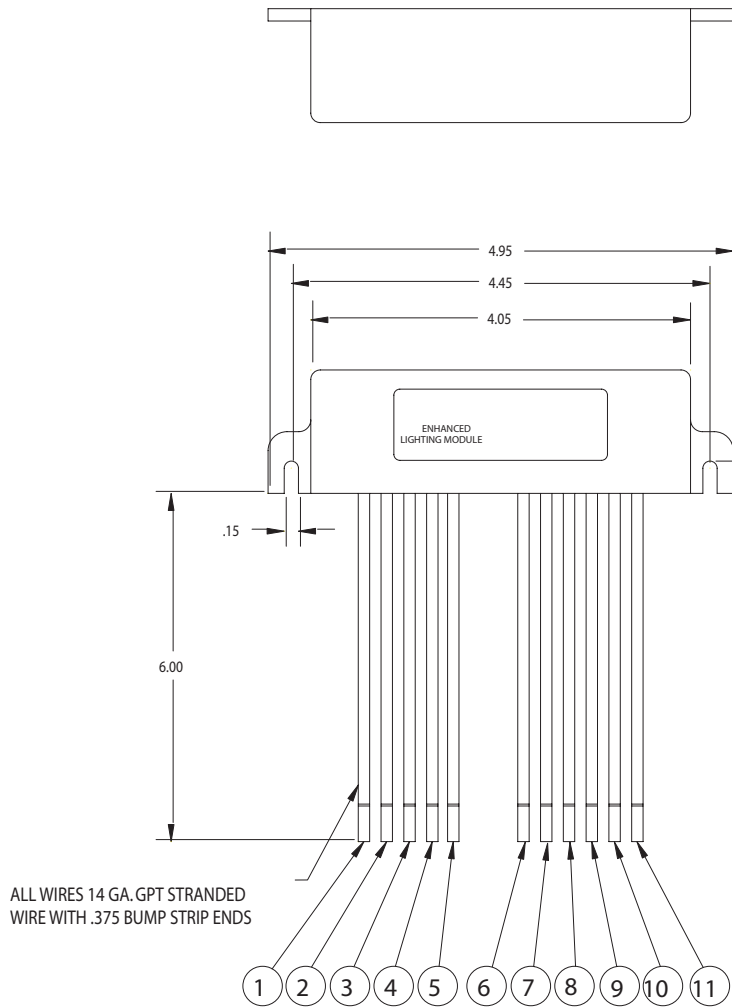

Normal Driving Mode

1. Red tail lights (low filament) steady burn if turned on.
2. Amber warning lights flashing in unison with tractor at 60 to 85 flashes per minute, controlled by flasher in tractor.
3. Red stop lights (High Filament) steady burn if the brake is applied.

Turning Mode

1. Amber flashing warning light and red light opposite the direction of turn shall become steady burning. The red light is on high filament.
2. Amber flashing warning light in direction of turn shall increase in flashing a minimum of 20 flashes per minute. In addition the red lamp in the direction of turning shall change from steady burn to flash in unison with the amber turn light and will flash from high red to low red filament.
3. If brake is applied during turning mode there will be no change in the state of the light; hence turning mode overrides brake signal.

NOTES:

1. ELECTRONIC CONVERTER SUPPLIED WITH CIRCUIT PROTECTION ON RED AND BLACK LEADS

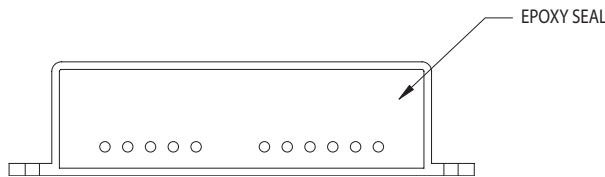

TECHNICAL INFORMATION IS CURRENT AS OF THE PRINTING OF THIS CATALOG. CONTACT TECHNICAL SERVICE FOR PERIODIC UPDATES.

6-WAY ROUND PIN CONNECTOR WIRING DIAGRAM

6-WAY MOLDED TRAILER/ SEALED CAR CONNECTOR & CABLE

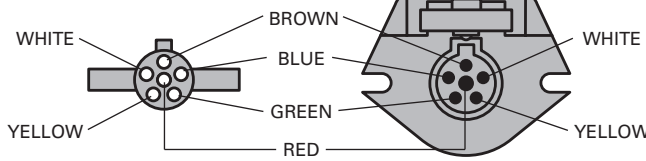

TRAILER END
As viewed from front face of 6-way connector with molded on cable.

CAR END
As viewed from front face of 6-way connector with sealed cable.

6-WAY ZINC DIE-CAST CONNECTOR

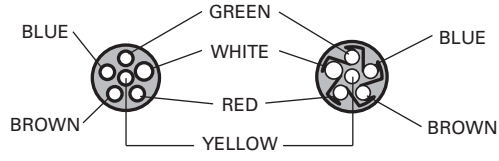

TRAILER END
As viewed from core back side where wires are attached with screws.

CAR END
As viewed from core back side where wires are attached with screws.

6 - WAY W I R I N G I N D E X

Wire Color & Gauge	Molded Trailer/Sealed Car Connector Terminal	Zinc Die-Cast Connector Terminal
White / 10/14 gauge	Common Ground	GD - Common Ground
Blue / 10/14 gauge	Electric Brake	S - Electric Brake
Green / 14 gauge	Right Stop & Turn	TM - Tail & License
Red / 10/14 gauge	Auxiliary	LT - Left Stop & Turn
Brown / 14 gauge	Tail & License	RT - Right Stop & Turn
Yellow / 14 gauge	Left Stop & Turn	A - Auxiliary

4-WAY ROUND PIN / FLAT CONNECTOR WIRING DIAGRAM

4-WAY ROUND PIN CONNECTOR

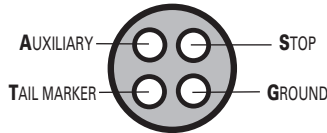

TRAILER END
As viewed from core back side where wires are attached with screws.

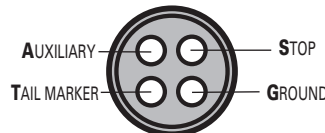

CAR END
As viewed from core back side where wires are attached with screws.

4-WAY FLAT CONNECTOR



5-WAY FLAT CONNECTOR WIRING DIAGRAM

5-WAY FLAT CONNECTOR

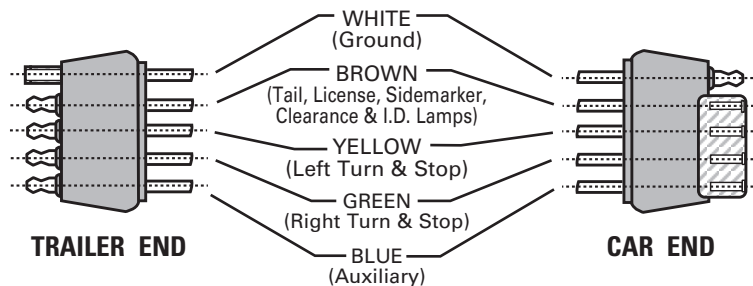

TECHNICAL INFORMATION IS CURRENT AS OF THE PRINTING OF THIS CATALOG. CONTACT TECHNICAL SERVICE FOR PERIODIC UPDATES.

7-WAY RV BLADE CONNECTOR WIRING DIAGRAM

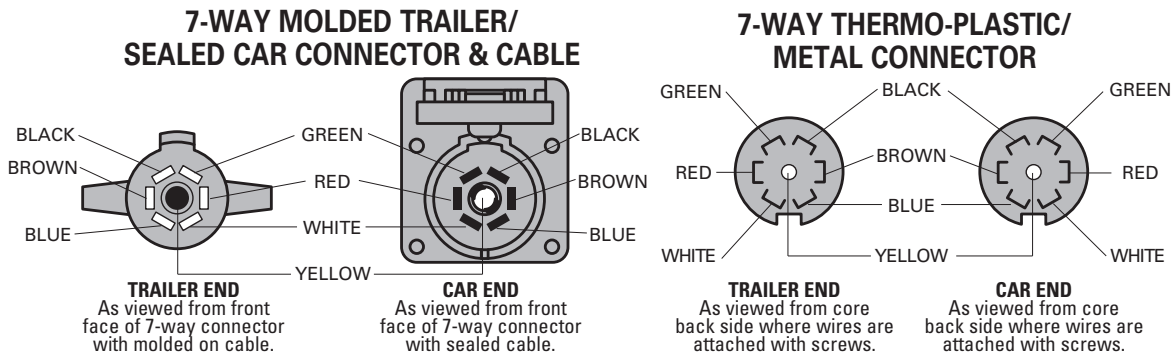

7 - WAY W I R I N G I N D E X

Wire Color & Gauge	Molded Trailer/Sealed Car Connector Terminal	Thermo-Plastic/Metal Connector Terminal
White / 10 gauge	Common Ground	#1 Common Ground
Blue / 12 gauge	Electric Brake	#2 Electric Brake
Green / 14 gauge	Tail & License	#3 Tail & License
Black / 10 gauge	Battery Charge	#4 Battery Charge
Red / 14 gauge	Left Stop & Turn	#5 Left Stop & Turn
Brown / 14 gauge	Right Stop & Turn	#6 Right Stop & Turn
Yellow / 14 gauge	Center Auxiliary	#7 Center Auxiliary

7-WAY MOLDED TRAILER CONNECTORS

PIN CLOCKING

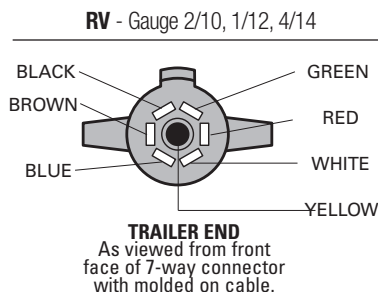

WIRE COLOR, GAUGE & FUNCTION
White / 10 gauge / Common Ground
Blue / 12 gauge / Electric Brake
Green / 14 gauge / Tail & License
Black / 10 gauge / Battery Charge
Red / 14 gauge / Left Stop & Turn
Brown / 14 gauge / Right Stop & Turn
Yellow / 14 gauge / Center Auxiliary

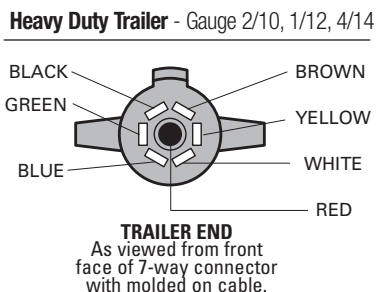

WIRE COLOR & GAUGE
White / 10 gauge
Blue / 12 gauge
Green / 14 gauge
Black / 10 gauge
Red / 14 gauge
Brown / 14 gauge
Yellow / 14 gauge

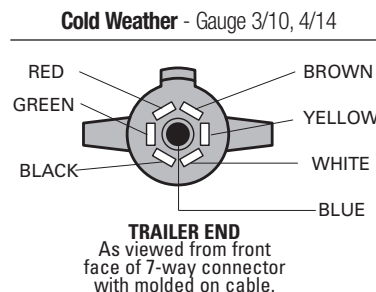

WIRE COLOR & GAUGE
White / 10 gauge
Blue / 14 gauge
Green / 14 gauge
Black / 10 gauge
Red / 10 gauge
Brown / 14 gauge
Yellow / 14 gauge

TECHNICAL INFORMATION IS CURRENT AS OF THE PRINTING OF THIS CATALOG. CONTACT TECHNICAL SERVICE FOR PERIODIC UPDATES.

NOTE: 7-Way Heavy Duty and Cold Weather trailer wiring diagrams represent wire location and color but are NOT supplied to represent any wire or color functions. Please contact your trailer manufacturer for further details.

WEIGHT DISTRIBUTION SYSTEMS

WEIGHT DISTRIBUTION SYSTEMS

Cequent Weight Distribution Systems

Reese® Strait-Line® System

Reese® SC Hitch Kits

Reese® Trunnion Style Weight Distribution

Reese® Round Bar Style Weight Distribution

Reese® Titan® Weight Distribution

Reese® Light Duty Weight Distribution Kit

Reese® 350 Mini-Lite Weight Distribution Kit

Draw-Tite® Trunnion Style Weight Distribution

Draw-Tite® Round Bar Style Weight Distribution

Pro Series™ Complete Round Bar Weight Distribution

Pro Series™ Trunnion Style Weight Distribution

Pro Series™ RB2 Weight Distribution

Pro Series™ RB3 Weight Distribution

SWAY CONTROLS

Reese® Dual Cam Sway Control

Reese® Friction Sway Control

Draw-Tite® Dual Cam Sway Control

Draw-Tite® Friction Sway Control

Pro Series™ Friction Sway Control

WEIGHT DISTRIBUTION ACCESSORIES

Hitch Bars

Chain Hangers

Snap Up Brackets



WEIGHT DISTRIBUTION SYSTEMS

Add a weight distributing system to provide a more level ride, greater steering and brake control.

THE DIFFERENCES ARE IN

construction materials, welding, manufacturing processes and hook-up. Adjustment is simple because of the easy-to-operate snap-up brackets that allow spring bar tension to be adjusted by changing links in the support chains. Rather than merely supporting the trailer tongue weight (TW), weight-distributing hitches apply leverage between the towing vehicle and trailer causing the TW to be carried by all axles of the tow vehicle and trailer.

A Weight Distributing Hitch System is composed of four major elements:

1. the hitch receiver
2. the weight distribution kit
3. the hitch ball
4. the sway control (see below)

They work in unison to provide complete towing system compatibility.

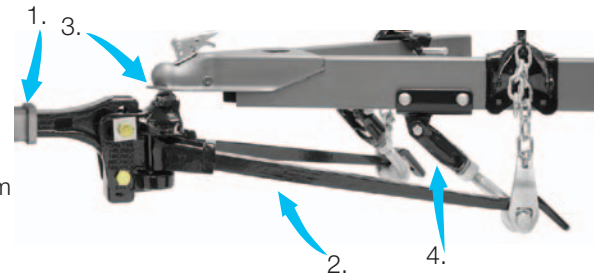

without weight distributing



with weight distribution

Dual Cam HP

SWAY CONTROL

Premier Sway Control – Unlike the friction sway control, the Dual Cam HP™ has the ability to forestall sway from the start in addition to resisting sway once it's begun. Works only when needed and allows free and easy vehicle/trailer interaction. Installs on the trailer and therefore doesn't require adjustment every time the tow vehicle and trailer are hooked up, unless ball mount height angle or the number of working chain links are changed.

- Integrated cams in the spring bars reduce noise
- No U-bolts to conflict with bottle racks or other A-frame mounted items
- Specific attachment reference points provided
- Simple, easy adjustment of centerline
- Fits more applications
- Improved installation times
- Years of extensive field testing



WHY CHOOSE OUR WEIGHT DISTRIBUTING?

We have been the leader in weight distributing systems for more than 55 years. Over those years, much has changed within the industries we serve. Tow vehicles and their frames have been made lighter while the trailers have become heavier. The technology utilized yesterday can no longer be used in today's world.

This is why we have been the leader in weight distributing systems for over 55 years.



QUALITY RAW MATERIALS

- Specially formulated bar stock is specified from the steel mill to meet demanding standards
- Inspected for adherence to specifications prior to being released to manufacturing



QUALITY MANUFACTURING PROCESS

- Thermal induction heating prepares the bar stock to be hot-rolled and tapered
- Hot-rolling/tapering (not forging) allows us to control the molecular structure in the steel to give it the desired strength and flexibility
- Austempering heat treat changes the chemical makeup (hardness) of the steel and transforms the raw stock into a spring bar

QUALITY TESTING

- Spring bars are tested for flexibility and its ability to accept deflection without bending or breaking.
- Rockwell hardness tests are performed to ensure that the raw stock has been transformed into a spring bar.



Round Style Spring Bars



Trunion Style Spring Bars

WE ARE THE INDUSTRY STANDARD IN SPRING BARS

STRAIT-LINE® SYSTEM

This is the ultimate hitch in detail and design. No other hitch gives the driver the control this one does at a reasonable price. The Strait-Line® Hitch consists of our patented Dual Cam High-Performance Sway Control and our High-Performance Weight Distributing System in one easy-to-install package.

The Strait-Line® Hitch was given this name as its pro-active design literally forces the trailer to stay in a straight line behind the tow vehicle. Sway is controlled by the Dual Cam High-Performance System. The stronger the sway force, the more the Dual Cam System works to stop it.

The Strait-Line® Hitch combines weight distributing with the best proven pro-active sway control system available in a newly-designed, easy-to-install kit.

- Simple installation and adjustment
- Fully automatic and self-centering
- Hooking up spring bars automatically hooks up sway control
- Reduced noise
- No U-bolts to interfere with bottle racks or other A-frame mounted items
- Specific attachment reference points provided
- Easy adjustment of centerline
- No need to relocate items on top of A-frame to install Dual Cam High-Performance Sway Control
- Limited lifetime warranty

STRAIT-LINE® TRUNNION BAR HITCH W/O HITCH BAR

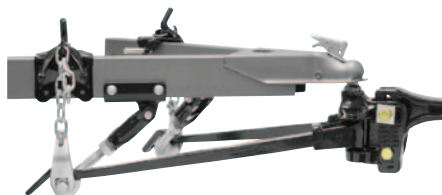

Part No.	Description
66072	Strait-Line® 600 Trunnion Bar (includes 66020 & 26002)
66073	Strait-Line® 800 Trunnion Bar (includes 66021 & 26002)
66074	Strait-Line® 1200 Trunnion Bar (includes 66022 & 26002)
66130	Strait-Line® 1500 Trunnion Bar for Ultra Frame® receivers (includes 66131 & 26002)
66075	Strait-Line® 1700 Trunnion Bar for Titan® receivers (includes 66006 & 26002)

STRAIT-LINE® TRUNNION BAR HITCH W/HITCH BAR #54970

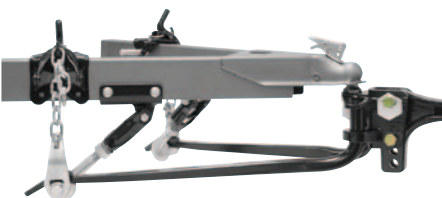

Part No.	Description
66082	Strait-Line® 600 Trunnion Bar w/Hitch Bar (includes 66540 & 26002)
66083	Strait-Line® 800 Trunnion Bar w/Hitch Bar (includes 66541 & 26002)
66084	Strait-Line® 1200 Trunnion Bar w/Hitch Bar (includes 66542 & 26002)

STRAIT-LINE® ROUND BAR HITCH W/O HITCH BAR

Part No.	Description
66076	Strait-Line® 600 Round Bar (includes 66065 & 26002)
66077	Strait-Line® 800 Round Bar (includes 66066 & 26002)
66078	Strait-Line® 1200 Round Bar (includes 66067 & 26002)

STRAIT-LINE® ROUND BAR HITCH W/HITCH BAR #54970

Part No.	Description
66086	Strait-Line® 600 Round Bar w/Hitch Bar (incl 65509 & 26002)
66087	Strait-Line® 800 Round Bar w/Hitch Bar (incl 67509 & 26002)
66088	Strait-Line® 1200 Round Bar w/Hitch Bar (incl 61009 & 26002)



The best integrated friction control system on the market with 6 points of true friction control.



REESE® SC HITCH KITS

- Ratings 600/800/1200/1500 lbs. with hitch bar #54970
- Integrated friction sway control with automotive friction material as used on vehicle brakes – sway control provides consistent control in various weather conditions
- Reese® style serrated washer system allows for easy head adjustment - does not require head removal for washer adjustment
- Raised hitch ball platform
- Clamp on brackets and adjustable pad hangers allow for placement on trailer frames without removing the gas bottles/batteries
- Lift handle accessory included to reduce the amount of lifting required by the trailer jack when preloading the WD system
- Tapered spring bars with preassembled trunnions reduce install time
- Tapered bars provide superior weight distribution performance over a variety of uneven road and weather conditions
- Proven durability
- Limited lifetime warranty

Four easy steps to hook up the Spring Bar

Step 1:

Place spring bar and lift handle onto clamp-on bracket

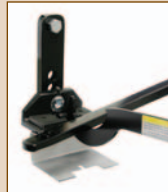

Step 2:

Rotate lift handle upward



Step 3:

Remove lift handle



Step 4:

Close and secure lid with pin

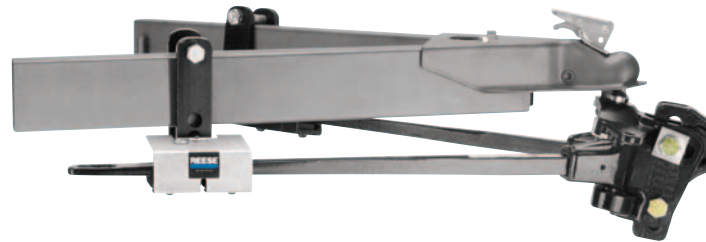

REESE® SC w/HITCH BAR #54970

Part No.	Description	Gross Trailer Wt.	Tongue Wt.
66151	Weight Distributing Hitch	10,000 lbs.	600 lbs.
66153	Weight Distributing Hitch	10,000 lbs.	800 lbs.
66155	Weight Distributing Hitch	12,000 lbs.	1,200 lbs.
66157	Weight Distributing Hitch	15,000 lbs.	1,500 lbs.

REPLACEMENT PARTS

Part No.	Description
58356	600 lbs. Trunnion Spring Bar
58357	800 lbs. Trunnion Spring Bar
58358	1,200 lbs. Trunnion Spring Bar
58359	1,500 lbs. Trunnion Spring Bar



TRUNNION STYLE

Reese® has combined the best of the features from all of our weight distributing kits to create the High-Performance Trunnion Kit. It includes a head design with superior strength and easy adjustment.

The head includes a forged raised ball platform and forged Trunnion mounts. The channel of the head utilizes our “serrated washer” design. The serrated washers make it easier to dial in the set up of the High-Performance Weight Distributing Kit.

In addition to the changes in the head, the High-Performance Weight Distributing Kit includes the highest rated spring bars per class in the industry. They also feature an integrated cam for easy set up with the optional Dual Cam High-Performance Sway Control. Other features include 9-link chains for easier set up on larger trailer frames and innovative snap-up brackets designed for superior strength and durability.

- Raised hitch ball platform eliminates the need for raised hitch balls
- Easy-to-use serrated washers for head adjustment
- Forged ball platform and spring bar mounts
- Rated up to 15,000 lbs. GTW and 1,500 lbs. TW
- Limited lifetime warranty

PATENTED INNOVATIVE DESIGN

Easy-to-use serrated washer

Raised hitch ball platform eliminates the need for raised hitch balls

Forged ball platform and spring bar mounts

PATENTED INNOVATIVE DESIGN

Forged integrated cam

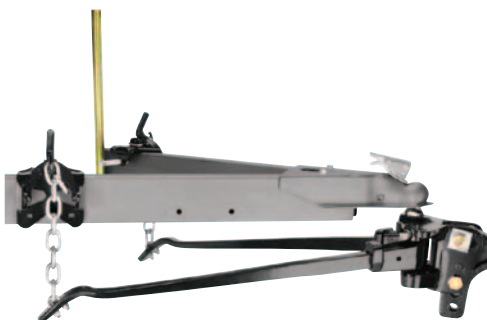

WEIGHT DISTRIBUTION W/O HITCH BAR

Part No.	Description	Gross Trailer Wt.	Tongue Wt.
66020	Weight Distributing Hitch	10,000 lbs.	600 lbs.
66021	Weight Distributing Hitch	10,000 lbs.	800 lbs.
66022	Weight Distributing Hitch	12,000 lbs.	1,200 lbs.
66131*	Weight Distributing Hitch	15,000 lbs.	1,500 lbs.

*U.S. Patent Nos. 5,375,867 and 5,465,991, other patents pending
* Designed to be used with Ultra Frame® receiver*

WEIGHT DISTRIBUTION W/HITCH BAR #54970

Part No.	Description	Gross Trailer Wt.	Tongue Wt.
66540	Weight Distributing Hitch	10,000 lbs.	600 lbs.
66541	Weight Distributing Hitch	10,000 lbs.	800 lbs.
66542	Weight Distributing Hitch	12,000 lbs.	1,200 lbs.

U.S. Patent Nos. 5,375,867 and 5,465,991, other patents pending

REPLACEMENT PARTS

Part No.	Description
58167	Adjustable Ball Mount w/hardware
22225	800 lbs. Trunnion Spring Bar
66009	1,200 lbs. Trunnion Spring Bar
58369	1,500 lbs. Trunnion Spring Bar
6637	Snap Up Bracket Assembly Kit w/handle (2-piece)
21501	Snap Up Bracket Assembly
58392	Snap Up Bracket for Titan® or Ultra Frame®
58207	Ball Mount Shim Kit



58167

ROUND BAR STYLE

The Round Bar Weight Distributing Hitch features easy-to-use adjusting blocks for easier and faster ball mount angle adjustment. It includes a one-piece cast head, snap-up brackets and chains; spring bars include an integrated cam for use with optional dual cam sway control.

In addition to the changes in the head, the Round Bar Weight Distributing Kit includes the highest rated spring bars per class in the industry. They also feature an integrated cam for easy set up with the optional Dual Cam High-Performance Sway Control. Other features include 9-link chains for easier set up on larger trailer frames and innovative snap-up brackets designed for superior strength and durability.

- Easy-to-use adjusting washers for head adjustment
- One piece cast head
- Rated up to 12,000 lbs. GTW and 1,200 lbs. TW
- Limited lifetime warranty

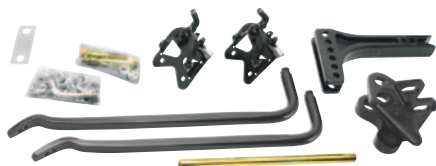

PATENTED INNOVATIVE DESIGN
Easy-to-use adjusting washer

One piece cast head

Integrated right hand sway control platform

PATENTED INNOVATIVE DESIGN
Forged integrated cam



WEIGHT DISTRIBUTION W/O HITCH BAR

Part No.	Description	Gross Trailer Wt.	Tongue Wt.
66065	Weight Distributing Hitch	10,000 lbs.	600 lbs.
66066	Weight Distributing Hitch	10,000 lbs.	800 lbs.
66067	Weight Distributing Hitch	12,000 lbs.	1,200 lbs.

WEIGHT DISTRIBUTION W/HITCH BAR #54970

Part No.	Description	Gross Trailer Wt.	Tongue Wt.
65509	Weight Distributing Hitch	10,000 lbs.	600 lbs.
67509	Weight Distributing Hitch	10,000 lbs.	800 lbs.
61009	Weight Distributing Hitch	12,000 lbs.	1,200 lbs.

REPLACEMENT PARTS

Part No.	Description
58112	Adjustable Ball Mount w/hardware
58113	600 lbs. Round Spring Bar
58114	800 lbs. Round Spring Bar
58115	1,200 lbs. Round Spring Bar
6637	Snap Up Bracket Assembly Kit w/handle (2-piece)
21501	Snap Up Bracket Assembly
58207	Ball Mount Shim Kit



58112



58113

58114

58115



6637



TITAN® WEIGHT DISTRIBUTING TRUNNION STYLE

Designed for loads beyond normal everyday towing situations, Titan® Weight Distributing Hitch system provides a trunnion design with the highest rating available in the towing industry. Coupled with a 2-1/2" Class V Titan® receiver, heavy loads are transported with ease. Ideal for commercial and industrial use.



- Trunnion style weight distributing kit with integrated cams for use with Dual Cam Sway Control
- Perfect for use with horse trailers and RV's with heavy tongue weights
- Adjustable hitch bar sold separately
- Great for agricultural, marine and recreational use
- Limited lifetime warranty

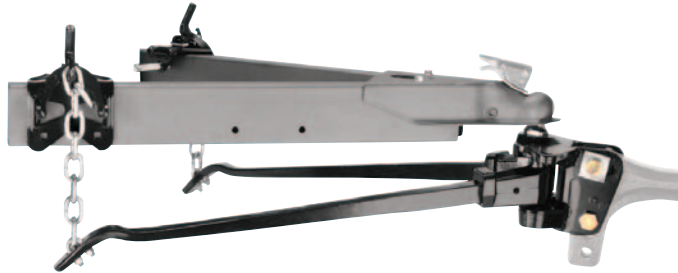

TITAN® WEIGHT DISTRIBUTING TRUNNION STYLE W/O HITCH BAR



54977

Part No.	Description	Gross Trailer Wt.	Tongue Wt.
66006	Weight Distributing Hitch	17,000 lbs.	1,700 lbs.

Note: Do not exceed tow vehicle, hitch or equipment ratings.

TITAN® HITCH BAR SELECTION CHART

Part No.	Total Ht Adj	Length (L)	Rise (R)	Drop (D)	GTW/TW (lbs.)
54976	6-1/4"	15"	5-1/4"	1-1/4"	17,000/1,700
54977	14-1/4"	15"	8-1/4"	5-3/4"	17,000/1,700

NOTE: Do not exceed tow vehicle, hitch or equipment rating

REPLACEMENT PARTS



58167

Part No.	Description
58167	Titan® Trunnion Bolt-Together Head Kit w/ hardware
58392	Snap Up Bracket for Titan® or Ultra Frame®



LIGHT DUTY WEIGHT DISTRIBUTING KIT

This light-duty weight distributing system is especially designed for use with lighter-weight trailers and pop-up campers. The center mount single bar is contoured to avoid interference with center-mounted jacks. The lift mechanism is designed to prevent interference with gas bottles or battery trays. It's easy to set up and use, and works with any 2" receiver.

The integrated lift bar feature provides the advantage of allowing a single person to operate from one side of the trailer. This system works with both side and center mounted tongue jacks. The sway control platform allows you to put a friction sway control on either side of the trailer.



Adjuster slides on frame to avoid gas bottles and battery trays; slides adjust 18 to 28 inches

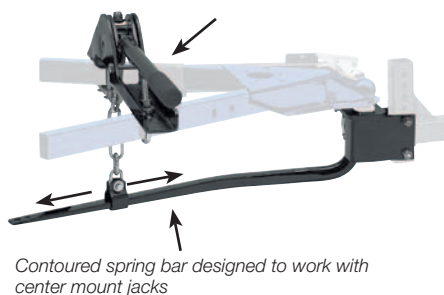

- Bolt-together welded head
- Integral sway control platform
- Innovative single spring bar design
- Assembly hardware and chains included
- Rated up to 4,000 lbs. GTW /400 lbs. TW
- Works with both side and center mount tongue jacks

Part No.	Description
66071	Light Duty WD for Pole Tongue Trailers
66069	Light Duty WD for A-Frame Trailers

*Note: Not recommended for use with surge brakes



350 MINI-LITE WEIGHT DISTRIBUTING KIT

This weight-distributing system is especially designed for use with light-weight trailers and fold-down campers. No chains or snap-up brackets are necessary and the 350 Mini-Lite works with any 2" receiver.

TRUNNION STYLE

- Hitch ball included
- Maximum tongue weight capacity of 350 lbs.
- Gross trailer weight of 3,500 lbs.

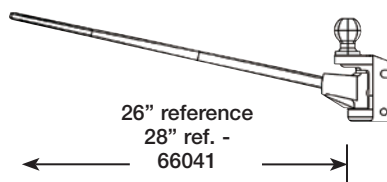

Mounts on "A" frame of trailer 26" back from center line of ball.

Part No.	Description
66024	Weight Distributing with 2" hitch ball; includes hitch ball, -adjustable hitch bar, spring bars, pins and wear pads
66041	Weight Distributing for Fleetwood/Coleman trailers with side-mounted swing-away jack; includes 2" Hitch Ball, Adjustable Hitch Bar, Spring Bars, pins and wear pads
54985	Tall Adjustable Hitch Bar for Mini Weight Distributing Hitch



TRUNNION STYLE

Draw-Tite® has combined the best of the features from all of our weight distributing kits to create the Trunnion Kit. It includes a head design with superior strength and easy adjustment.

The head includes a forged raised ball platform and forged Trunnion mounts. The channel of the head utilizes our “serrated washer” design. The serrated washers make it easier to dial in the set up of the Weight Distributing Kit.

In addition to the changes in the head, the Weight Distributing Kit includes the highest rated spring bars per class in the industry. They also feature an integrated cam for easy set up with the optional Dual Cam High-Performance Sway Control. Other features include 9-link chains for easier set up on larger trailer frames and innovative snap-up brackets designed for superior strength and durability.



PATENTED INNOVATIVE DESIGN

Easy-to-use serrated washer

Raised hitch ball platform eliminates the need for raised hitch balls

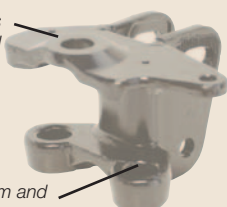

Forged ball platform and spring bar mounts

PATENTED INNOVATIVE DESIGN

Forged integrated cam



- Raised hitch ball platform eliminates the need for raised hitch balls
- Easy-to-use serrated washers for head adjustment
- Forged ball platform and spring bar mounts
- Rated up to 15,000 lbs. GTW and 1,500 lbs. TW
- Limited lifetime warranty

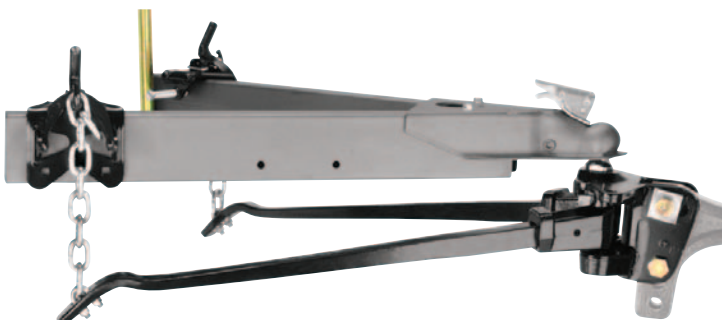

WEIGHT DISTRIBUTION W/O HITCH BAR

Part No.	Description	Gross Trailer Wt.	Tongue Wt.
7901	Weight Distributing Hitch	10,000 lbs.	600 lbs.
7902	Weight Distributing Hitch	10,000 lbs.	800 lbs.
7903	Weight Distributing Hitch	12,000 lbs.	1,200 lbs.
66131*	Weight Distributing Hitch	15,000 lbs.	1,500 lbs.

* Designed to be used with Ultra Frame® receiver

REPLACEMENT PARTS

Part No.	Description
6637	Snap Up Bracket Assembly Kit (qty 2) w/handle
21501	Snap Up Bracket Assembly (qty 1)
62167	Bolt together single ear head assembly & hardware
6664	800 lbs. trunnion spring bars (qty 2), chains & fasteners
6666	1,200 lbs. trunnion spring bars (qty 2), chains & fasteners
58369	1,500 lbs. trunnion spring bars (qty 1), chains & fasteners
58392	Snap Up Bracket for Titan® or Ultra Frame®



62167



ROUND BAR STYLE

The Round Bar Weight Distributing Hitch features easy-to-use adjusting blocks for easier and faster ball mount angle adjustment. It includes a one-piece cast head, snap-up brackets and chains; spring bars include an integrated cam for use with optional dual cam sway control.

In addition to the changes in the head, the Round Bar Weight Distributing Kit includes the highest rated spring bars per class in the industry. They also feature an integrated cam for easy set up with the optional Dual Cam High-Performance Sway Control. Other features include 9-link chains for easier set up on larger trailer frames and innovative snap-up brackets designed for superior strength and durability.

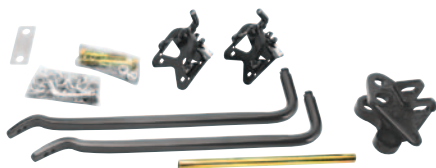

PATENTED INNOVATIVE DESIGN

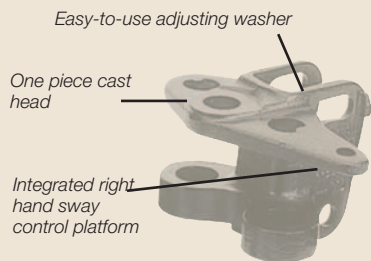

PATENTED INNOVATIVE DESIGN

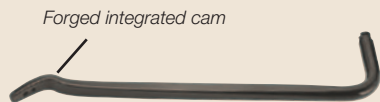

- Easy-to-use adjusting washers for head adjustment
- One piece cast head
- Rated up to 12,000 lbs. GTW and 1,200 lbs. TW
- Limited lifetime warranty

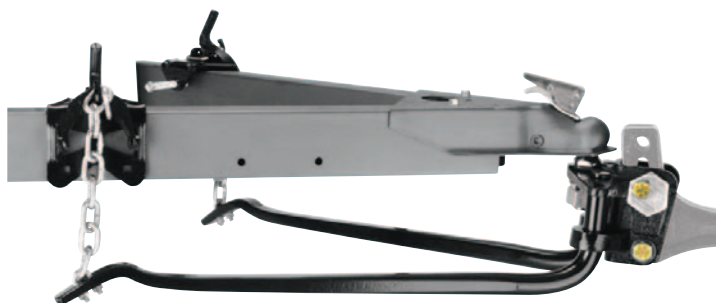

WEIGHT DISTRIBUTION W/O HITCH BAR

Part No.	Description	Gross Trailer Wt.	Tongue Wt.
3201	Weight Distributing Hitch	10,000 lbs.	600 lbs.
3202	Weight Distributing Hitch	10,000 lbs.	800 lbs.
3203	Weight Distributing Hitch	12,000 lbs.	1,200 lbs.

REPLACEMENT PARTS

Part No.	Description
6637	Snap Up Bracket Assembly Kit (qty 2) w/handle
21501	Snap Up Bracket Assembly (qty 1)
62112	Bolt together head assembly & hardware
62113	600 lbs. round spring bar (qty 1)
62114	800 lbs. round spring bar (qty 1)
62115	1,200 lbs. round spring bar (qty 1)





PRO SERIES™ COMPLETE ROUND BAR KIT

The innovative Pro Series™ Complete Round Bar weight distribution is engineered to provide the features you expect in a weight distribution kit at an economical price.

- Provides everything needed to improve towing, safety and performance right out of the box
- Preinstalled and torqued sway control ball and 2-5/16" hitch ball, u-bolts and chains
- Fabricated head and welded hitch bar
- Includes friction sway control and mounting hardware
- 10 year warranty
- Available in 550/750/1,000 lbs kits



Part No.	Description	Gross Trailer Wt.	Tongue Wt.
49901	Pro Series™ Complete Round Bar WD Kit	10,000 lbs.	550 lbs.
49902	Pro Series™ Complete Round Bar WD Kit	10,000 lbs.	750 lbs.
49903	Pro Series™ Complete Round Bar WD Kit	10,000 lbs.	1,000 lbs.

Note: Minimum purchase requirements for these products. Please contact your Cequent Performance Products sales representative for further details.

REPLACEMENT PARTS

Part No.	Description
58444	Pro Series™ Ball Mount Shim Kit

PRO SERIES™ TRUNNION STYLE

The innovative Pro Series™ Trunnion weight distribution is engineered to provide the features you expect in a weight distribution kit at an economical price.

- New combination single piece cast head
- Easy to use adjusting washers
- Unique washer design allows for quick spring bar tension adjustment
- Round tapered spring bars
- Head is compatible with optional Friction Sway Control (each side)
- Includes hitch bar #63970
- 10 year limited warranty

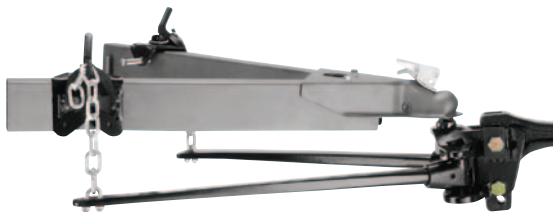

WEIGHT DISTRIBUTION w/HITCH BAR #63970

Part No.	Description	Gross Trailer Wt.	Tongue Wt.
49585	Weight Distributing Hitch	10,000 lbs.	600 lbs.
49586	Weight Distributing Hitch	10,000 lbs.	800 lbs.
49587	Weight Distributing Hitch	12,000 lbs.	1,200 lbs.

Available in skid quantities of 20. (Example: 49585-020)



PRO SERIES™ RB2

The innovative Pro Series™ Round Bar weight distribution is engineered to provide the features you expect in a weight distribution kit at an economical price.

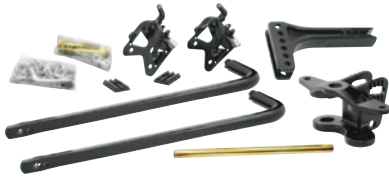

- New combination single piece cast head
- Easy to use adjusting washers
- Unique washer design allows for quick spring bar tension adjustment
- Head is compatible with optional Friction Sway Controls (each side)
- Includes hitch bar #63970
- 10 year limited warranty



WEIGHT DISTRIBUTION w/HITCH BAR #63970

Part No.	Description	Gross Trailer Wt.	Tongue Wt.
49568	Weight Distributing Hitch	10,000 lbs.	600 lbs.
49569	Weight Distributing Hitch	10,000 lbs.	800 lbs.
49570	Weight Distributing Hitch	12,000 lbs.	1,200 lbs.

Available in skid quantities of 20. (Example: 49570-020)

PRO SERIES™ RB3

- Fabricated head and welded hitch bar
- Available in 550/750/1,000 lbs kits
- Head is compatible with optional Friction Sway controls (each side)
- 10 year limited warranty

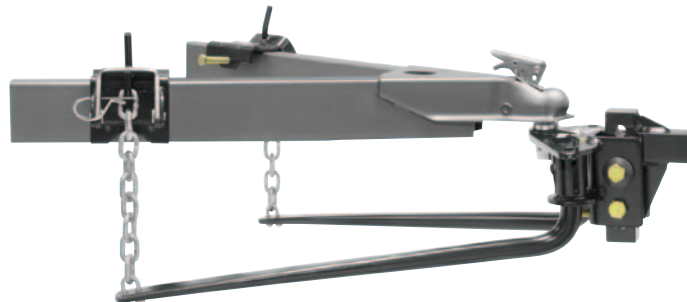

WEIGHT DISTRIBUTION w/HITCH BAR

Part No.	Description	Gross Trailer Wt.	Tongue Wt.
49581	Weight Distributing Hitch	10,000 lbs.	550 lbs.
49582	Weight Distributing Hitch	10,000 lbs.	750 lbs.
49583	Weight Distributing Hitch	10,000 lbs.	1,000 lbs.

Available in skid quantities of 20. (Example: 49583-020)



54980

ADJUSTABLE BALL MOUNTS W/ HITCH BARS

Part No.	Description
54980	Complete Adjustable Ball Mount with 54970 Hitch Bar

Dual Cam HP



DUAL CAM HIGH-PERFORMANCE SWAY CONTROL

This patented product is Reese® Products main technique for controlling trailer sway. Unlike Friction Sway Control, this approach works to control sway from the start rather than just resisting sway once it's begun. And it works only when needed. The advantage of the Dual Cam System is its ability to forestall sway in addition to sway resistance. It works to hold down the start of swaying activity while at the same time allowing free and easy vehicle and trailer interaction. Another advantage of the Dual Cam System is that it is installed on the trailer and therefore does not require adjustment every time the towing vehicle and trailer are hooked up, unless hitch weight or tow vehicle loading are changed.

- Integrated cams into the spring bars reduce noise
- No U-bolts to interfere with bottle racks or other A-frame mounted items
- Specific attachment reference points provided
- Fits most applications
- Improved installation times
- Years of extensive field testing



26002

Part No.	Description
26025	Classic Dual Cam High Performance Sway Control
26002	Dual Cam High Performance Sway Control

Weight distributing hitch not included; use of sway controls with surge brakes not recommended; this product is recommended to be used with weight distribution that has the integrated spring bars only



3442



58060

FRICTION SWAY CONTROL

- Installs and removes easily
- Removes with two spring locking pins
- Heavy construction for added reliability
- Friction brake keeps trailer and tow vehicle stable
- Quick attachment to trailer frame and ball mount
- Can be used on left and right side of trailer



26660

Part No.	Description
26660	Sway Control Assembly and fasteners - (boxed)
3442	Weld-on Sway Control adapter
58060	Replacement Sway Control ball 1-1/4" x 5/8"
58062	Replacement Ball Plate Assembly

Weight distributing hitch not included; use of sway controls with surge brakes is not recommended

Dual Cam HP



26102



3442



58060



3400

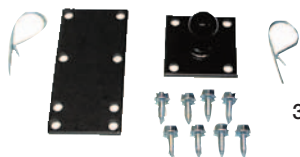

83660



26003
26005

DUAL CAM HIGH-PERFORMANCE SWAY CONTROL



This patented product is Draw-Tite's main technique for controlling trailer sway. Unlike Friction Sway Control, this approach works to control sway from the start rather than just resisting sway once it's begun. And it works only when needed. The advantage of the Dual Cam System is its ability to forestall sway in addition to sway resistance. It works to hold down the start of swaying activity while at the same time allowing free and easy vehicle and trailer interaction. Another advantage of the Dual Cam System is that it is installed on the trailer and therefore does not require adjustment every time the towing vehicle and trailer are hooked up, unless hitch weight or tow vehicle loading are changed.

- Integrated cams into the spring bars reduce noise
- No U-bolts to interfere with bottle racks or other A-frame mounted items
- Specific attachment reference points provided
- Fits most applications
- Improved installation times
- Years of extensive field testing

Part No.	Description
26015	Classic Dual Cam High Performance Sway Control
26102	Dual Cam High Performance Sway Control

Note: Weight distributing hitch not included; use of sway controls with surge brakes not recommended; this product is recommended to be used with weight distribution that has the integrated spring bars only.

FRICTION SWAY CONTROL

- Installs and removes easily
- Removes with two spring locking pins
- Heavy construction for added reliability
- Friction brake keeps trailer and tow vehicle stable
- Quick attachment to trailer frame and ball mount
- Can be used on left and right side of trailer



Part No.	Description
3400	Sway Control Assembly and fasteners - (boxed)
3442	Weld-on Sway Control adapter
58060	Replacement Sway Control ball 1-1/4" x 5/8"
58062	Replacement Ball Plate Assembly

Note: Weight distributing hitch not included; use of sway controls with surge brakes is not recommended.



Part No.	Description
83660	Pro Series Friction Sway Control
3442	Weld-on Sway Control adapter
58060	Replacement Sway Control ball 1-1/4" x 5/8"
58062	Replacement Ball Plate Assembly

Note: Weight distributing hitch not included; use of sway controls with surge brakes is not recommended.

BOLT-ON MOUNTING ADAPTERS FOR SWAY CONTROL

- Easy bolt-on installation
- Bulk packaged
- Black powder coat finish over e-coat

Part No.	Description
26003	Sway Control Adapter Bracket for Class III & IV 2" ball mounts
26005	Sway Control Adapter Bracket for Class II 1-1/4" drawbars

26003 cannot be used with Class I or Class II Drawbars.

26005 cannot be used with Class I Drawbars.

Ball platform does not prevent adapter from turning during tightening.

WEIGHT DISTRIBUTING HITCH BARS

Sold separately from the Weight Distributing Hitch Kits, hitch bars offer a full range of style and adjustability. Designed for use with all Trunnion and Round Bar Weight Distributing Kits.

- Angled, extended, "T" and deep drop designs available
- Designed for use in the rise or drop position
- 2" x 2" solid shanks
- Black powder coat finish over over e-coat

HOW TO MEASURE FOR THE PROPER HITCH BAR

Refer to the diagrams below to assist in determining the correct Length, Rise & Drop required when selecting the correct hitch bar for your Weight Distributing Hitch.

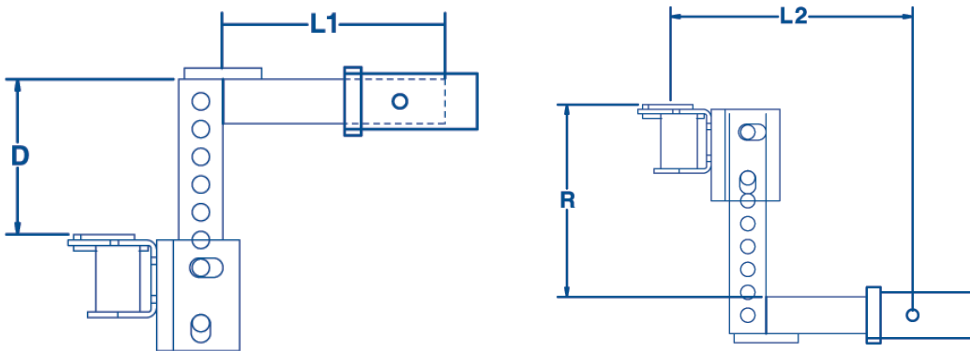

Illustrations show Adjustable Hitch Bar

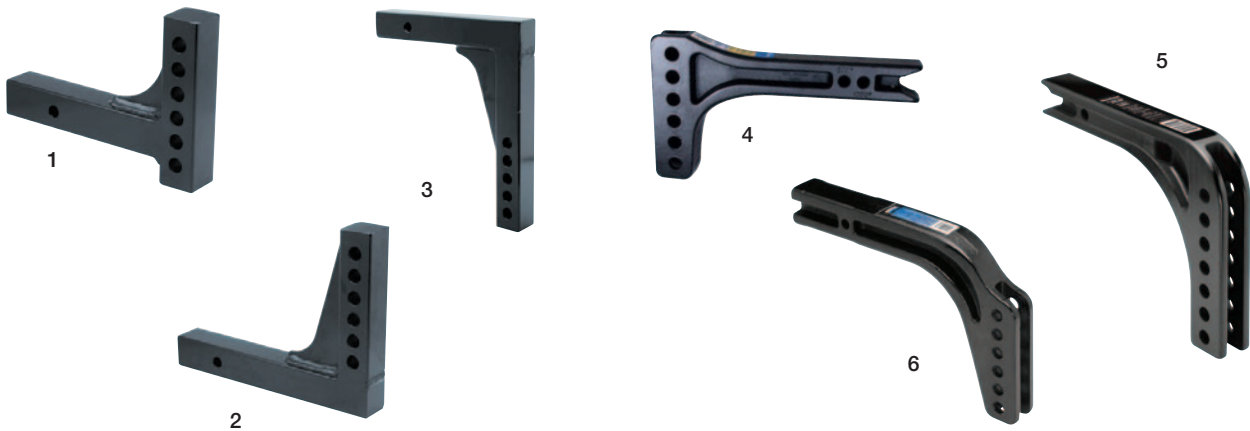

Part No	Style	Shank Size	Capacity lbs. (TW)	Shank bar Length (L1)	Length(L2) Round	Trunnion	Drop (D) Round	Trunnion	Rise(R) Round	Trunnion
54985	4	2"	350	12-1/2"	N/A	14-3/8"	N/A	6"	N/A	9-1/2"
3210	1	2"	1,400	10"	12-1/2"	11-7/8"	2-1/4"	1-1/4"	5-3/4"	7"
3212	1	2"	1,400	12"	14-1/2"	13-7/8"	2-1/4"	1-1/4"	5-3/4"	7"
3214	1	2"	1,400	14"	16-1/2"	15-7/8"	2-1/4"	1-1/4"	5-3/4"	7"
3215	2	2"	1,400	11"	13-1/2"	12-7/8"	6-3/4"	5-3/4"	10-1/4"	11-1/2"
3344	3	2"	1,400	11"	13-1/2"	12-7/8"	8-5/8"	7-5/8"	N/A	N/A
54970	4	2"	1,500	12-1/4"	14-3/4"	14"	2"	1-1/4"	5-1/4"	6-1/2"
63970	4	2"	1,500	12-1/4"	14-3/4"	14"	2"	1-1/4"	5-1/4"	6-1/2"
63971	5	2"	1,500	12-1/2"	15"	14-3/8"	6-1/2"	5-3/4"	N/A	N/A
54976	4	2-1/2"	1,700	15"	N/A	16-7/8"	N/A	1-1/4"	N/A	6-1/2"
54977	6	2-1/2"	1,700	15"	N/A	16-7/8"	N/A	5-3/4"	N/A	10-1/2"

NOTE: Do not exceed tow vehicle, hitch or equipment rating



5780

LOAD-MASTER TRAILER TONGUE WEIGHT SCALE

- Load-Master is a hydraulic pressure gauge for measuring trailer tongue weights from 0 to 2,000 lbs.

Part No.	Description
5780	Load-Master Trailer Tongue Weight Scale



3280

POLE TONGUE ADAPTER

A Pole Tongue Adapter is used as a mounting platform for the Lift Brackets of a Weight Distributing Hitch System when a trailer has a pole or straight tongue rather than an A-frame tongue.

- Fits all lift units regardless of manufacturer
- Fits tongue widths from 1-5/8" to 5"
- Fits tongue heights from 3" to 6"

Part No.	Description	Gross Trailer Wt.	Tongue Wt.
3280	Pole Tongue Adapter and Fastener Kit	7,500 lbs.	750 lbs.
58393	Pole Tongue Adapter and Fastener Kit	14,000 lbs.* 12,000 lbs.**	1400 lbs.* 1200 lbs.**

Note: Not for use with light duty weight distributing hitch

** When mounted on top of the tongue*

*** When mounted below the tongue*

WEIGHT DISTRIBUTING CHAIN HANGERS

For trailers with tongue interference (gas bottles, batteries, covered frames, etc.) where snap up brackets (#21501) won't install easily, we offer two easy-to-install options.



58305

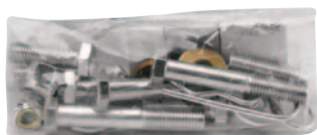

58306

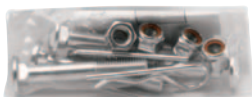

- Black powder coat finish over e-coat
- Installs quickly! (approximately 15 minutes)
- Includes hardware

Part No.	Description	Gross Trailer Wt.	Tongue Wt.
58305	Chain Hanger, Bolt On	14,000 lbs.	1400 lbs.
58306	Chain Hanger, Clamp On	14,000 lbs.	1400 lbs.



21501

WEIGHT DISTRIBUTING SNAP UP BRACKETS

- Rugged positive locking design
- Unit locks using safety pin (#55180)
- Narrower, for increased frame clearance
- One-piece cast chain hook
- Black powder coat finish over e-coat

Part No.	Description
6637	Snap Up Bracket Assembly Kit w/handle (2- piece)
21501	Snap Up Bracket
58162	Snap Up Handle
58392	Snap Up Bracket for Titan® or Ultra Frame®

FIRST IN FIFTH WHEELS

Reese®, the brand that started the RV towing industry, continues to lead it today. Over half the fifth wheels on the road are towed by Reese fifth wheel hitches, providing unmatched safety, reliability, and performance.



16K Fifth Wheel Hitch

- 16,000 lbs. gross;
- 4,000 lb. pin weight capacity
- Adjustment height - 14-1/2" to 18-1/4"
- Quick installation - removes in seconds
- Fore-and-aft and side-to-side 4-5° pivot
- Limited lifetime warranty



20K Fifth Wheel Hitch

- 20,000 lbs. gross,
- 5,000 lbs. pin weight capacity
- 14" to 18" vertical height adjustment
- Quick installation - removes in seconds
- Features Reese Elite Series head
- Limited lifetime warranty



22K Fifth Wheel Hitch

- 22,000 lbs. gross,
- 5,500 lbs. pin weight capacity
- Adjustment height - 14-1/4" to 18-1/4"
- 6 Degrees side to side pivot
- Quick installation - removes in seconds
- Limited lifetime warranty



30K Low Profile Fifth Wheel Hitch

- 30,000 lbs. gross;
- 7,500 lbs. pin weight capacity
- Vertically adjust 3"
- Side-tilt design
- Easily accessible handle
- Ideal for medium duty conversion trucks
- Limited lifetime warranty



Elite Fifth Wheel Hitches

- 18K model - 18,000 lbs. gross,
- 4,500 lbs. pin weight capacity
- 25K model - 25,000 lbs. gross,
- 6,250 lbs. pin weight capacity
- Wider footprint for increased stability
- Custom vehicle-specific mounting kits
- Limited lifetime warranty

FIFTH WHEEL SLIDERS AVAILABLE

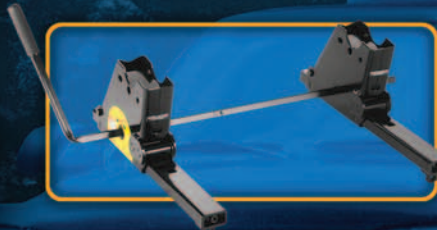

Sqaure Tube Slider

- Fits 16K & 20K Fifth Wheels



Elite Slider

- Fits 18K Elite Fifth Wheels

REESE
PIONEERING
PERFORMANCE

Don't forget to ask about our Vehicle Specific Quick Install Brackets...they'll reduce installation time by up to 50%. Save time and money!

FIFTH WHEEL HITCHES

FIFTH WHEEL HITCHES

Reese® Elite™ Fifth Wheel Hitches

Reese® Elite™ Slider

Reese® Elite™ Rail Kits

Reese® Fifth Wheel Hitches

Draw-Tite® Fifth Wheel Hitches

Pro Series™ Fifth Wheel Hitches

Fifth Wheel Sliders

FIFTH WHEEL HITCH ACCESSORIES

Lube Plates

Accessory Kit

Chain Bracket Kit

Pull Pin Lock Plates

Fifth Wheel Locks

Fifth Wheel Rail Kits

Fifth Wheel Adapter Brackets

FIFTH WHEEL APPLICATIONS

Fifth Wheel Application Guide

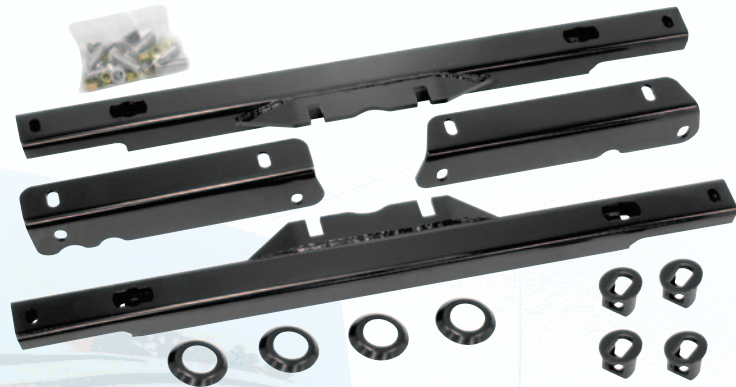



ELITE™



30143



Includes 90° Wire Harness 50-97-410



30142



Includes 90° Wire Harness 50-97-410



30144

PRE ASSEMBLED 25K ELITE™

- 25,000 lbs. gross / 6,250 lbs. pin weight capacities
- 14" – 16-1/2" vertical adjustment
- Improved 4 way head pivot
- 4° side to side pivot for better control
- Forged single jaw
- Increased king pin/jaw contact design
- Self latching jaw design
- King pin indicator
- Wider footprint for increased stability
- Stamped rounded head
- Wider 9" (vs 6") king pin funnel area on head
- Vehicle specific under bed mounting kits
- Lockable handle (lock sold separately)
- 1/4" turn handle "quick lock" mount system
- Non-pin mounting reduces slop
- Contemporary 21st century appearance
- Folding tab washers for easy installation
- Extended length handle
- Pre-assembled fifth wheel units
- Saves approximately one hour of assembly time
- Foot assembly is hand tightened
- Includes wrench to tighten foot assembly
- Shipped in one convenient carton
- Limited lifetime warranty

Part No.	Description
30143	25K Elite™

Note: Will not fit trucks with beds shorter than 6' in length unless used with Sidewinder™. Will not fit trucks with flareside/stepside.

PRE ASSEMBLED 18K ELITE™

All 25K features other than gross and pin weight capacity.

- 18,000 lbs. gross / 4,500 lbs. pin weight capacities
- 14" – 18" vertical adjustment

Part No.	Description
30142	18K Elite™ - pre assembled
30144	18K Elite™ with Slider - pre assembled

Note: Will not fit trucks with beds shorter than 6' in length unless used with Sidewinder™. Will not fit trucks with flareside/stepside.

ELITE™ SLIDER

Designed for short bed and extended cab short bed pickups to provide additional turning clearance and to prevent damage to truck and trailer in tight locations at low speeds.

- 10" travel
- Fits 18K Elite™ fifth wheel
- Round rail design allows for smoother operation
- Operation from either side of unit (handle can be mounted on either side)
- Angled steel rollers reduces binding
- Operates even when vehicle not in straight line
- Operation up to 45° angle.
- Lock pin for additional security
- Rubber grip handle for comfortable operation
- The vertical adjustment is limited to 16" - 18"



30070

Part No.	Description
30070	Elite™ Slider, for use with the 18K Elite™ fifth wheels only

ELITE™

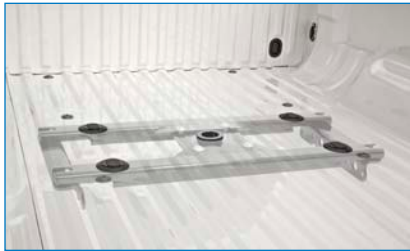
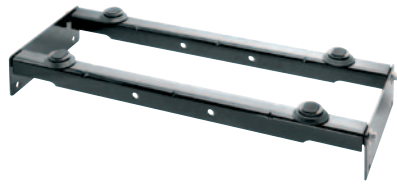

ELITE™ RAIL KITS

Elite™ Rail Kits are designed for use with the Elite™ Systems only.

- “Power Puck” mounting system provides uninhibited use of truck bed when fifth wheel or gooseneck is dismantled
- Wider platform/mounting footprint (increased stability)
- Custom-fit under-bed mounting system
- Black powder coat finish

REESE

SEE APPLICATION GUIDE FOR VEHICLE SPECIFIC RAIL KITS

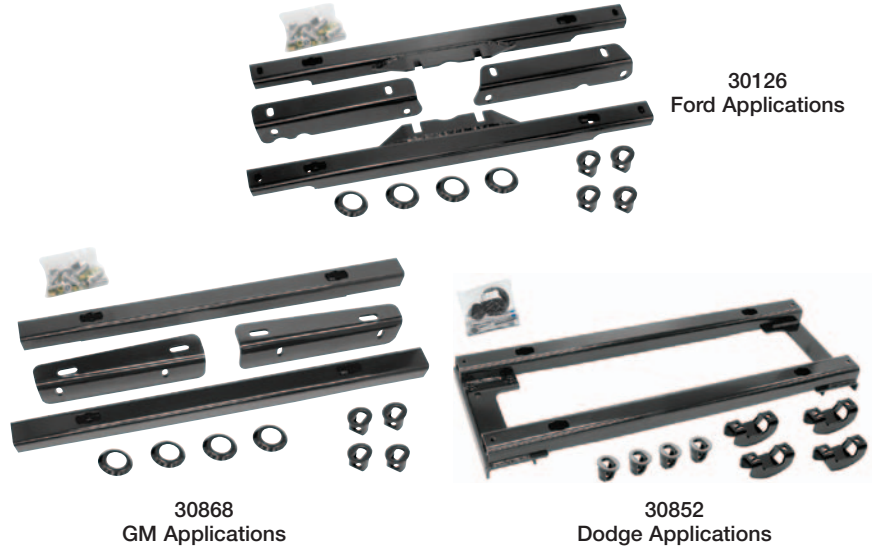

ACCESSORY/REPLACEMENT PARTS

Part No.	Description
30149	Elite™ Rail Kit Accessory, Plastic Bedliner Puck Adapter Kit (includes: (4) Pucks & (4) Spacers)
58458	Replacement Part, Trim Rings (4) for GM and Dodge Elite™ Rail Kits



RAIL KIT MOUNTING ADAPTER

- 20,000 lbs. gross/5,000 lbs. pin weight capacity
- SAE J2638 fatigue and static tested
- Use with Ford OEM under-bed rail kit or Reese® Elite™ under-bed rail kits
- The robust Reese adapter will not touch or scratch the truck bed
- Works with any 15K, 16K, or 20K standard fifth wheel hitch
- Uses the fast and secure Reese® patented latching system
- Built-in handles for safe, easy installation and removal
- Limited lifetime warranty



Part No.	Description
30156	Rail Kit Mounting Adapter



REESE® R16 FIFTH WHEEL

Reese®, the brand that started the towing industry once again revolutionizes the fifth wheel hitch with the introduction of the new R16. Reese® remains unmatched in safety, reliability and performance.

- 16,000 lbs. gross / 4,000 lbs. pin weight capacities
- Optional slider available for additional turning clearance
- NEW CONTOURED HANDLE
 - Customized grip includes universal control instructions
 - New control handle eliminates separate latch and high visibility for system lock and load
- PREMIUM REESE ARCH
 - Pin mounting holes better align with current rail kits, reducing looseness
 - SAE J2638 COMPLIANT
 - Based on heavy duty, accelerated life cycle criteria developed by SAE for fifth wheels
 - Fatigue and static tested to pass 900,000 cycles
- SIDEWINDER COMPATIBLE
 - Premium choice for short bed trucks
- NEW CAST HEAD
 - Commercial durability and strength
 - Improved head funneling for king pin to latch
 - Patent pending king pin indicator is highly visible
- NEW CAST JAW SYSTEM
 - Double jaw mechanism, heavier for longer wear, improved tolerances, eliminating chucking in jaw system
 - Improved life and wear with added grease points
- NEW CAST PIVOT BEAM
 - Incorporates a vibration isolator system for vertical and longitudinal vibration dampening and improved ride
 - Wider mounting for better stability and reduced wear
 - Easier assembly of cast pivot beam to cross member
 - Vertical height adjustment from 14" to 18"
 - Head and pivot beam can be offset 1" front or rear to maximize performance
 - Requires rails & installation kit (sold separately)
- Limited lifetime warranty



CONTOURED HANDLE



CAST HEAD & JAW



CAST PIVOT BEAM

Part No.	Description
30866	R16 Fifth Wheel Hitch
30869	R16 Fifth Wheel Hitch and Round Tube Slider

Note: Will not fit trucks with beds shorter than 6' in length unless used with Sidewinder™. Will not fit trucks with flareside/stepside.

REESE® R20 FIFTH WHEEL

- 20,000 lbs. gross / 5,000 lbs. pin weight capacities
- All R16 features PLUS additional longitudinal dampening located in crossbar to improve towing when going over pot holes and rough terrain
- Optional slider available for additional turning clearance

Part No.	Description
30867	R20 Fifth Wheel Hitch
30870	R20 Fifth Wheel Hitch and Round Tube Slider

Note: Will not fit trucks with beds shorter than 6' in length unless used with Sidewinder™. Will not fit trucks with flareside/stepside.

New

REESE® ROUND TUBE SLIDER

- Up to 20,000 lbs
- 11” travel rearward from center of rail
- Slider system re-engineered to be the best in the industry
- Current slider systems expanded to give true ease and precision
- Contoured rollers float from side to side to accommodate mounting systems that may not be fully square
- Embossed roller supports for low friction and longer wear
- Forged mounting feet for wide consistent attachment to rails
- Updated pin mounting holes to better align with the current rail kits and reduce play
- Plated rails hold up longer for extended wear
- SAE J2638 COMPLIANT
 - First slider engineered and tested to SAE J2638
 - Based on heavy duty, accelerated life cycle criteria developed by SAE for fifth wheel and gooseneck
 - SAE J2638 is a fatigue and static requirements of new European style test of 900,000 cycles
 - New customized grip includes universal control instructions

Part No.	Description
50024	Round Tube Slider

New



REESE® CUSTOM MOUNTED RAIL KIT

- SAE J2638 COMPLIANT
 - Based on heavy duty, accelerated life cycle criteria developed by SAE for fifth wheels
 - J2638 are fatigue and static requirements based on the European style test of 900,000 cycles
- HARDWARE
 - Grade 8 hardware, meets all Canadian requirements
- FAST CUSTOM MOUNT SYSTEM
 - Rails are wider (48”) for faster install , because the mounting points are outside the truck frame, allowing the installer to avoid under-bed components

Part No.	Description
30153	Reese® Outboard Fifth Wheel Mounting Rails Only (10 bolt design)

REESE® FIFTH WHEEL OUTBOARD INSTALLATION BRACKETS AND HARDWARE



56001

Part No.	Description
56001	Reese® Outboard Fifth Wheel Bracket Kit for 2011 Chevy/GMC 2500/3500HD
56001-53	Reese® Outboard Fifth Wheel Rail and Bracket Kit (Includes #56001 & #30153) for 2011 Chevy/GMC 2500/3500HD (10 Bolt)
56002	Reese® Outboard Fifth Wheel Bracket Kit for 2011 Ford Super Duty 250/350
56002-53	Reese® Outboard Fifth Wheel Rail and Bracket Kit (Includes #56002 & #30153) for 2011 Ford Super Duty 250/350 (10 Bolt)



30054

REESE® 30K FIFTH WHEEL LOW PROFILE HITCH

- Low profile design can be vertically adjusted 3" to permit level trailering (9-1/2" to 12-1/2") above vehicle deck
- Side-tilt design reduces vehicle frame stress, creating a smoother, more comfortable ride and making hook-up and un-hook much easier
- Specially designed and engineered for the serious tower, primarily on medium-duty conversion trucks
- Actuating handle is more easily accessible than most fifth wheels, making hook-up quicker and more convenient
- 30,000 lbs. capacity; 7,500 lbs. pin weight capacity
- Limited lifetime warranty

Part No.	Description
30054	Reese® 30K Fifth Wheel Complete Base rails not used with this model. Mounts directly to medium-duty truck

Note: Will not fit trucks with beds shorter than 6' in length unless used with Sidewinder™. Will not fit trucks with flareside/stepside.

REESE® 22K FIFTH WHEEL

Features side-to-side pivot to better accommodate hook-ups on uneven ground. Quick installation, strong, reliable performance and easy removal to allow full truck bed access.

- Two-jaw locking system
- Fore-and-aft and side-to-side pivot
- Locking jaw handle
- Vertically adjusts from 14-1/4" to 18-1/4"
- 22,000 lbs. towing capacity
- 5,000 lbs. pin weight capacity
- Solid base assembly for superior stability
- Requires rails & installation kit (sold separately)
- Limited lifetime warranty



30033

Part No.	Capacity	Pin Capacity	Adjustment Heights
30033	22,000 lbs.	5,000 lbs.	14-1/4" to 18-1/4"

Rails and installation kit must be ordered separately (#30035).

Note: Will not fit trucks with beds shorter than 6' in length unless used with Sidewinder™. Will not fit trucks with flareside/stepside.



Includes 90° Wire Harness 50-97-410

REPLACEMENT PARTS

Part No.	Description
30729	22K Head Assembly with pivot beam (Reese®)
30730	22K Base Assembly with adj. brackets (Reese®)
58187	22K Pivot Beam only (Reese®)
58099	22K Head only (Reese®)
58385	22K Adjustment bracket

THE FIFTH WHEEL YOU KNOW, BUT BETTER!



Reese® 20K fifth wheel

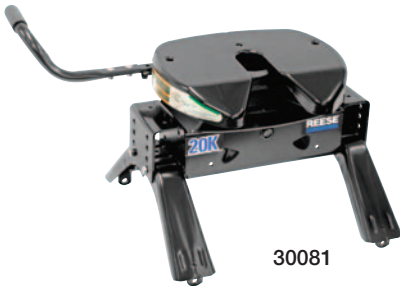

30081

Reese® 20K fifth wheel
offered with round tube slider



30083

Reese® 20K fifth wheel
offered with square tube slider



30084



**TOWING HAS NEVER BEEN EASIER WHEN USING
THE REESE® 20K FIFTH WHEEL SYSTEM.**

Features our Elite™ head, with the base and mounting kit that you already know & love from our Reese® line of fifth wheel hitches!

The above bed rail system uses the popular universal mounting kit 30035 (sold separately) or the vehicle specific custom quick install kits which reduce install time by up to fifty percent.

REESE® 20K FIFTH WHEEL

- 20,000 lbs. gross / 5,000 lbs. pin weight capacities
- 14" to 18" vertical height adjustment
- Features Elite™ Series head...
 - Tough, heavy-duty stamped head looks just like the ones on the real tractor-trailers!
 - 4 way (front & back/side-to-side) head pivot
 - 6° side-to-side head pivot
 - King pin indicator
 - Increased king pin contact design
 - Wider 9" king pin funnel area
 - Forged single jaw
 - Self-latching jaw design
- Limited lifetime warranty

Part No.	Description
30081	Reese® 20K Fifth Wheel
30083	Reese® 20K Fifth Wheel with round tube slider
30084	Reese® 20K Fifth Wheel with square tube slider

Rails and installation kit must be ordered separately (#30035).

Note: Will not fit trucks with beds shorter than 6' in length unless used with Sidewinder™. Will not fit trucks with flareside/stepside.



30047

REESE® 16K FIFTH WHEEL

Featuring side-to-side pivot action to better accommodate hook-ups on uneven ground. Quick-easy installation, strong performance and easy removal in just seconds to allow full access to the truck bed.

- Two-jaw locking system
- Fore-and-aft and side-to-side 4°-5° pivot
- Locking jaw handle
- Vertically adjusts from 14-1/2" to 18"
- 16,000 lbs. towing capacity
- 4,000 lbs. pin weight capacity
- Wide stance one-piece legs for improved stability
- Requires rails & installation kit (sold separately)
- Limited lifetime warranty

Part No.	Capacity	Pin Capacity	Adjustment Heights
30047	16,000 lbs.	4,000 lbs.	14-1/2" to 18"
30051	16,000 lbs	4,000 lbs.	15" to 18" with square tube slider
30075	16,000 lbs.	4,000 lbs.	15" to 18" with round tube slider

Rails and installation kit must be ordered separately (#30035).

Note: Will not fit trucks with beds shorter than 6' in length unless used with Sidewinder™. Will not fit trucks with flareside/stepside.



30727

REPLACEMENT PARTS

Part No.	Description
30047A	Head with Head Support & hardware
58146	Fifth Wheel Head only (service kit)
58147	Cross Member – head support only
30727	Fifth Wheel Legs only (set of two)



6021



Includes 90° Wire Harness 50-97-410

22K SELECT SERIES FIFTH WHEEL

Features side-to-side pivot to better accommodate hook-ups on uneven ground. Quick installation, strong, reliable performance and easy removal to allow full truck bed access.

- Two-jaw locking system
- Fore-and-aft and side-to-side pivot
- Locking jaw handle
- Vertically adjusts from 14-1/4" to 18-1/4"
- 22,000 lbs. towing capacity
- 5,000 lbs. pin weight capacity
- Solid base assembly for superior stability
- Requires rails & installation kit (sold separately)
- 10 year limited warranty

Part No.	Capacity	Pin Capacity	Adjustment Heights
6021	22,000 lbs.	5,000 lbs.	14-1/4" to 18-1/4"

Rails and installation kit must be ordered separately (#30035, 10-bolt).

Rails and installation kit must be ordered separately (#30095, 4-bolt).

Note: Will not fit trucks with beds shorter than 6' in length unless used with Sidewinder™. Will not fit trucks with flareside/stepsides.

REPLACEMENT PARTS

Part No.	Description
6026	22K Head Assembly
58187	22K Pivot Beam only
58385	22K Adjustment bracket



6032

16K SELECT SERIES FIFTH WHEEL

Featuring side-to-side pivot action to better accommodate hook-ups on uneven ground. Quick, easy installation, strong performance and easy removal in just seconds to allow full access to the truck bed.

- Two-jaw locking system
- Fore-and-aft and side-to-side 4°-5° pivot
- Locking jaw handle
- Vertically adjusts from 14-1/2" to 18"
- 16,000 lbs. towing capacity
- 4,000 lbs. pin weight capacity
- Wide stance one-piece legs for improved stability
- Requires rails & installation kit (sold separately)
- 10 year limited warranty

Part No.	Capacity	Pin Capacity	Adjustment Heights
6032	16,000 lbs.	4,000 lbs.	14-1/2" to 18"
6033	16,000 lbs.	4,000 lbs.	15" to 18" with square tube slider
40119	16,000 lbs.	4,000 lbs.	15" to 18" with round tube slider

Rails and installation kit must be ordered separately (#30035, 10-bolt).

Rails and installation kit must be ordered separately (#30095, 4-bolt).

Note: Will not fit trucks with beds shorter than 6' in length unless used with Sidewinder™. Will not fit trucks with flareside/stepsides.

REPLACEMENT PARTS

Part No.	Description
6042	16K Fifth Wheel Head only (service kit)
6044	Fifth Wheel Leg



PRO SERIES™ 20,000 LBS. FIFTH WHEEL HITCHES



30118



30119



30120

- Covers all 20K user requirements, including light commercial
- Full floating head for improved hooking and unhooking, as well as ride
- Double jaw system completely surrounds the king pin for significantly reduced wear
- Lubricated and clamped side joints for tight and efficient operation
- Lightweight, easy to install and remove
- Adjustable height, from 13" to 17"
- Sturdy, robust and reliable
- One-piece formed legs, provides a wider footprint for superior stability
- Sidewinder compatible, preferred for short bed pickups
- Fits universal 4-bolt rail kit (P/N 30095) Must utilize center attachment points for 20K capacities included with 20K Fifth Wheel Hitches) or 10-bolt rail kit (P/N 30035)
- Compatible slider system available
- Best value in marketplace, more combination options
- Available with your choice of either #30035 or #30095 base rail kits
- 10 year limited warranty

Part No.	Description
30118	Pro Series™ 20,000 lbs. Fifth Wheel Hitch Head and Support <i>Legs, Rails, and Installation Kit sold separately</i>
30119*	Pro Series™ 20,000 lbs. Fifth Wheel Hitch Head, Support, and Legs <i>Rails and Installation Kit sold separately</i>
30120*	Pro Series™ 20,000 lbs. Fifth Wheel Head, Support, Legs, and Rails (4 bolt)
30132*	Pro Series™ 20,000 lbs. Fifth Wheel Head, Support, Legs, and Rails (10 bolt)

* Available in skid quantities of 16 (Example: 30120-016)

Note: Will not fit trucks with beds shorter than 6' in length unless used with Sidewinder™. Will not fit trucks with flareside/stepsides.

PRO SERIES™ 20,000 LBS. FIFTH WHEEL HITCHES WITH SQUARE TUBE SLIDER

Designed for shortbed trucks to provide clearance and prevent damage to truck and trailer in tight spaces at slow speeds



30121

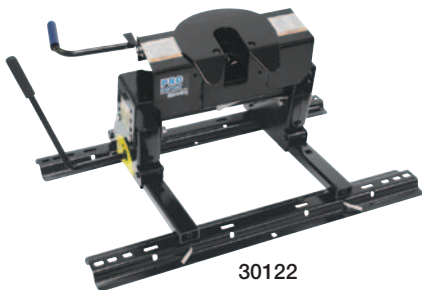

30122

- 10" travel front to back
- Adjustable with trailer attached
- Can be used with full size or mini trucks
- Double jaw system completely surrounds the king pin for significantly reduced wear
- Full floating head for improved hooking and unhooking, as well as ride
- Jaw handle with tab for optional padlock security (padlock not included)
- Vertically adjusts from 13" to 17" to best match-up with different trailers
- 20,000 lbs. towing capacity
- 5,000 lbs. pin weight capacity
- Wide stance one-piece legs for improved stability
- Available with your choice of either #30035 or #30095 base rail kits
- 10 year limited warranty

Part No.	Description
30121*	Pro Series™ 20,000 lbs. Fifth Wheel Hitch Head, Support, and Pro Series™ Slider <i>Rails and Installation Kit sold separately</i>
30122*	Pro Series™ 20,000 lbs. Fifth Wheel Hitch Head, Support, Pro Series™ Slider, and Rails (4 bolt)
30133*	Pro Series™ 20,000 lbs. Fifth Wheel Hitch Head, Support, Pro Series™ Slider, and Rails (10 bolt)

* Available in skid quantities of 16 (Example: 30121-016)

Note: Will not fit trucks with beds shorter than 6' in length unless used with Sidewinder™. Will not fit trucks with flareside/stepsides.



30854



30855



30856

PRO SERIES™ 16,000 LBS. FIFTH WHEEL HITCHES

- Covers all 16K user requirements
- Full floating head for improved hooking and unhooking, as well as ride
- Has a proven enhanced slide bar system for worry free towing
- Lightweight, easy to install and remove
- Adjustable height, from 13” to 17”
- One-piece formed legs, provides a wider footprint for superior stability
- Sidewinder compatible, preferred for short bed pickups
- Fits universal 4-bolt rail kit (P/N 30095) or 10-bolt rail kit (P/N 30035)
- Compatible slider system available
- Sturdy, robust and reliable
- Best value in marketplace, more combination options
- Available with your choice of either #30035 or #30095 base rail kits
- 10 year limited warranty

Part No.	Description
30854	Pro Series™ 16,000 lbs. Fifth Wheel Hitch Head and Support <i>Legs, Rails and Installation Kit sold separately</i>
30855*	Pro Series™ 16,000 lbs. Fifth Wheel Hitch Head and Support and Legs <i>Rails, and Installation Kit sold separately</i>
30856*	Pro Series™ 16,000 lbs. Fifth Wheel Hitch Head, Support, Legs, and Rails (4 bolt)
31859*	Pro Series™ 16,000 lbs. Fifth Wheel Hitch Head, Support, Legs, and Rails (10 bolt)

* Available in skid quantities of 16 (Example: 30856-016)
 Note: Will not fit trucks with beds shorter than 6' in length unless used with Sidewinder™. Will not fit trucks with flareside/stepsides.

PRO SERIES™ 16,000 LBS. FIFTH WHEEL HITCHES WITH SQUARE TUBE SLIDER

Designed for shortbed trucks to provide clearance and prevent damage to truck and trailer in tight spaces at slow speeds

- 10” travel front to back
- Adjustable with trailer attached
- Can be used with full size or mini trucks
- Has a proven enhanced slide bar system for worry free towing
- Full floating head for improved hooking and unhooking, as well as ride
- Jaw handle with tab for optional padlock security (padlock not included)
- Vertically adjusts from 13” to 17” to best match-up with different trailers
- 16,000 lbs. towing capacity
- 4,000 lbs. pin weight capacity
- Wide stance one-piece legs for improved stability
- Available with your choice of either #30035 or #30095 base rail kits
- 10 year limited warranty



30857

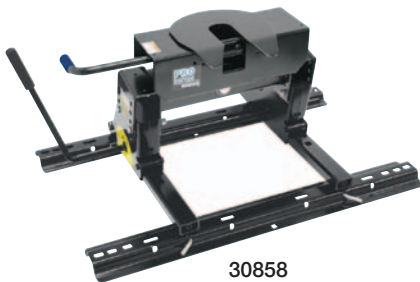

30858

Part No.	Description
30857*	Pro Series™ 16,000 lbs. Fifth Wheel Hitch Head, Support, and Pro Series™ Slider <i>Rails and Installation Kit sold separately</i>
30858*	Pro Series™ 16,000 lbs. Fifth Wheel Hitch Head, Support, Pro Series™ Slider, and Rails (4 bolt)
31860*	Pro Series™ 16,000 lbs. Fifth Wheel Hitch Head, Support, Pro Series™ Slider, and Rails (10 bolt)

* Available in skid quantities of 16 (Example: 31860-016)
 Note: Will not fit trucks with beds shorter than 6' in length unless used with Sidewinder™. Will not fit trucks with flareside/stepsides.



PRO SERIES™ 15,000 LBS FIFTH WHEEL HITCHES

An economy fifth wheel hitch that doesn't act like one. The Pro Series™ offers features only found in larger units. Installs and removes easily for full bed access.

- Rounded slide bar mechanism designed for automatic latching with cushion grip handle
- 4-way pivoting head for easier hookup on uneven ground
- Jaw handle with tab for padlock security (padlock not included)
- Vertically adjusts from 13" to 17" to best match-up with different trailers
- 15,000 lbs. towing capacity
- 3,750 lbs. pin weight capacity
- Wide stance one-piece legs for improved stability
- Available with your choice of either #30035 or #30095 base rail kits
- 10 year limited warranty

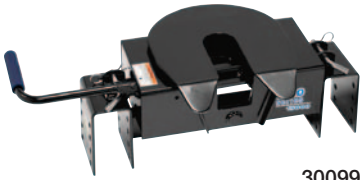

30099

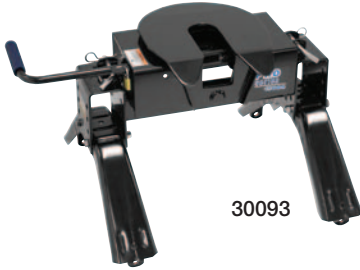

30093

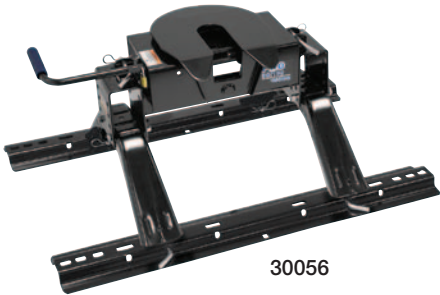

30056

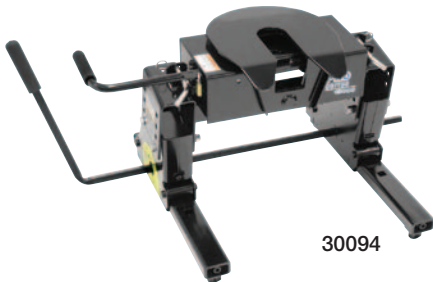

30094

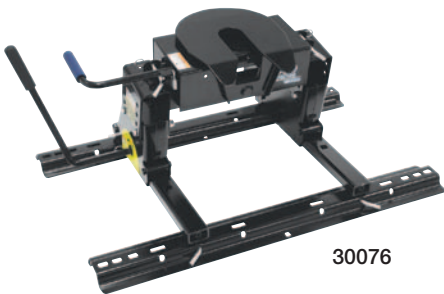

30076

Part No.	Description
30099	Pro Series™ 15,000 lbs. Fifth Wheel Hitch Head, Support, Legs, Rails and Installation Kit sold separately
30093*	Pro Series™ 15,000 lbs. Fifth Wheel Hitch Head and Support and Legs, Rails, and Installation Kit sold separately
30056*	Pro Series™ 15,000 lbs. Fifth Wheel Hitch Head, Support, Legs, and Rails (4 bolt)
30128*	Pro Series™ 15,000 lbs. Fifth Wheel Hitch Head, Support, Legs, and Rails (10 bolt)

* Available in skid quantities of 16 (Example: 30056-016)

Note: Will not fit trucks with beds shorter than 6' in length unless used with Sidewinder™. Will not fit trucks with flareside/stepsides.

PRO SERIES™ 15,000 LBS. FIFTH WHEEL HITCHES WITH SQUARE TUBE SLIDER

Designed for shortbed trucks to provide clearance and prevent damage to truck and trailer in tight spaces at slow speeds

- 10" travel front to back
- Adjustable with trailer attached
- Can be used with full size or mini trucks
- Rounded slide bar mechanism designed for automatic latching with cushion grip handle
- 4-way pivoting head for easier hookup on uneven ground and smoother towing
- Jaw handle with tab for optional padlock security (padlock not included)
- Vertically adjusts from 13" to 17" to best match-up with different trailers
- 15,000 lbs. towing capacity
- 3,750 lbs. pin weight capacity
- Wide stance one-piece legs for improved stability
- Available with your choice of either #30035 or #30095 base rail kits
- 10 year limited warranty

Part No.	Description
30094*	Pro Series™ 15,000 lbs. Fifth Wheel Hitch Head, Support, and Pro Series™ Slider Rails and Installation Kit sold separately
30076*	Pro Series™ 15,000 lbs. Fifth Wheel Hitch Head, Support, Pro Series™ Slider, and Rails. (4 bolt)
30129*	Pro Series™ 15,000 lbs. Fifth Wheel Hitch Head, Support, Pro Series™ Slider, and Rails. (10 bolt)

* Available in skid quantities of 16 (Example: 30076-016)

Note: Will not fit trucks with beds shorter than 6' in length unless used with Sidewinder™. Will not fit trucks with flareside/stepsides.

Designed for short bed trucks and extended cab short bed pickups to provide additional turning clearance and to prevent damage to truck when spotting trailer. Fits Pro Series™ and 16K Select Series Fifth Wheel Hitches.

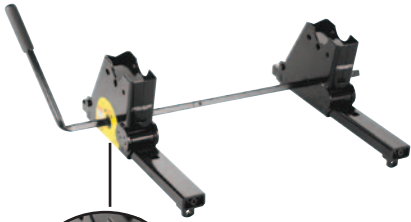

30048

Requires #30035 or #30095 universal base rail kit (sold separately)



SQUARE TUBE SLIDER (KWIK-SLIDE™)



- 6 roller design
- 10" travel fore-and-aft
- Works with full size and compact trucks
- Fully adjustable with trailer attached
- Minimum 13" extended trailer pin box recommended
- Requires #30035 or #30095 Universal Base Rail Kit (sold separately)

Part No.	Description
30048	Kwik-Slide™ Slider for 16K Select Series fifth wheel hitches

Rails and installation kit must be ordered separately (#30035, 10-bolt).
 Rails and installation kit must be ordered separately (#30095, 4-bolt).
 Note: Check clearance between king pin bed and tailgate before moving to maneuvering position.

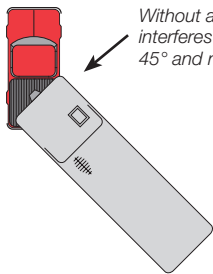

Without a slider, a standard hookup interferes with corner of trailer at 45° and may cause damage

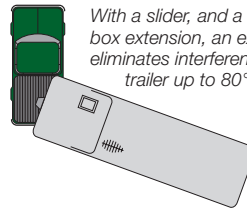

With a slider, and a minimum 13" pin box extension, an extra 10" of clearance eliminates interference with corner of trailer up to 80°

PRO SERIES™ FIFTH WHEEL SLIDER UNIT W/ROLLERS



- 4 roller design
- 10" travel fore-and-aft
- Works with full size and compact trucks
- Fully adjustable with trailer attached
- Minimum 13" extended trailer pin box recommended
- Requires #30035 or #30095 Universal Base Rail Kit (sold separately)
- 10 year limited warranty

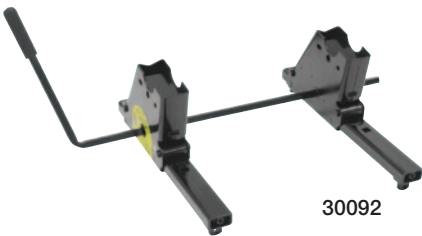

30092

Requires #30035 or #30095 universal base rail kit (sold separately)

Part No.	Description
30092	Pro Series™ Fifth Wheel Slider Unit w/Rollers for 15K, 16K and 20K Head Assemblies (requires head assembly)

Rails and installation kit must be ordered separately (#30035, 10-bolt).
 Rails and installation kit must be ordered separately (#30095, 4-bolt).
 Note: Check clearance between king pin bed and tailgate before moving to maneuvering position.



83001
83002

ELITE™ & REESE® FIFTH WHEEL LUBE PLATES



Nylon lube plate protects fifth wheel plate from the wear of normal towing

- Eliminates the need for messy grease

Part No.	Description
83001	12" Lube Plate for use with Elite™ & Reese® 20K fifth wheel hitches only
83002	Fifth Wheel 10" Lube Plate for Reese® 16K & 22K fifth wheels



6011

FIFTH WHEEL LUBE PLATE



- Large surface for extra protection

Part No.	Description
6011	Fifth Wheel 10" Lube Plate for 16K and 22K Select Series™ & Pro Series™ Fifth Wheels



30053

FIFTH WHEEL ACCESSORY KIT



- Everything a new fifth wheel buyer needs to get started
- Lube, plate, cover, king pin lock, lock links

Part No.	Description
30053*	Fifth Wheel Starter Kit (for Reese® only)
30055*	Cover only

*Note: Does not fit Elite™ or 20K Reese®.

50223



CHAIN BRACKET KIT

Fits Reese® fifth wheel rails and most popular brands. Provides secure attachment for trailer safety chains.

Part No.	Description
50223	Chain Bracket Kit, 18,000 lbs. each



lock not included



58093

PULL PIN LOCK PLATES

- Prevents theft of fifth wheel and unwanted removal of pull pins
- Add a standard padlock to make the locking plate a security device

Part No.	Description
58093	Pin Lock Plates for 1/2" pull pins for fifth wheels (4 pack)



50222

New

FIFTH WHEEL LOCKS

Part No.	Description
KING PIN LOCKS	
50222	Fifth Wheel King Pin Lock
63251	Fifth Wheel King Pin Lock, Extruded T6 Tempered Aluminum Body
RAIL LOCK	
63254	Fifth Wheel Rail Lock, Push Button, Replaces One Locking Pin



New

63251



63254



Rail and installation kits must be ordered separately. Does not work with Elite™ fifth wheel hitches.

FIFTH WHEEL RAILS & INSTALLATION KIT

Rails and installation kits for full-size trucks. Quick and easy installation with full truck bed access. For use on all fifth wheel hitches except Elite™ (formerly Signature Series.)

Part No.	Description
30035	Rails and Mounting Bracket Kit for full size trucks (10 bolt design)
58058	Rails (only) for full size trucks (10 bolt design)
30439	Mounting Brackets and Hardware (only) for full size trucks (10 bolt design)
58314	Mounting Brackets (only) for full size trucks (10 bolt design)
30153	Reese® Outboard Fifth Wheel Mounting Rails Only (10 bolt design) New
30095	Rails and Mounting Bracket Kit for full size trucks (4 bolt design)
30124	Rails (only) for full size trucks (4 bolt design)
30125	Mounting Brackets & Hardware (only) for full size trucks (4 bolt design)



FIFTH WHEEL ADAPTER BRACKETS AND HARDWARE

Part No.	Description
30080	Fifth Wheel Rails and Installation Kit for (2004-2011 Ford F-150 New Body Style) Includes Brackets and Hardware (10 - Bolt Design)
58023*	Fifth Wheel Bracket Kit (2002-2008 Dodge RAM 1500 Pickup, 2003-2010 Dodge RAM 2500/3500 HD Pickup w/o Overload Springs) (10 - Bolt Design)
58166	Fifth Wheel Tube Spacer Kit (2002-2008 Dodge RAM 1500 Pickup, 03-10 Dodge RAM 2500/3500 HD Pickup) (10 - Bolt Design)
58186	Fifth Wheel Bracket Kit (2003-2011 Dodge RAM 2500/3500 HD Pickup w/Overload Springs) (10 - Bolt Design)
58197	Fifth Wheel Spacer Kit (00-06 Toyota Tundra, Includes Qty. 8 Additional 3/16" Spacers) (10 - Bolt Design)
58208	Chevrolet Composite Bed Kit for Above the Bed Rail Kit #30035 (10 - Bolt Design) used w/Select Series Fifth Wheels & 25K Above-Bed Gooseneck
58309	Fifth Wheel Spacer Kit (2007-2012 Toyota Tundra, Includes (2) 1/2" x 1-1/4" Spacer, (3) 1/2"-13 x 1-3/4" Carriage Bolt, (3) 1/2"-13 x 3" Carriage Bolt, (2) Bevel Washer) (10 - Bolt Design)
58386	Fifth Wheel Bracket Kit (2009-2012 Dodge RAM 1500 Pickup, Except Models w/Dual Exhaust) (10 - Bolt Design)
58405	Fifth Wheel Bracket Kit (2004-2011 Nissan Titan) (10 - Bolt Design)
58425	Fifth Wheel Bracket Kit (2005-2012 Ford F-250/F-350 Super Duty & 2008-2011 Ford F-450 Super Duty, Except Cab & Chassis) (4 - Bolt Design)
58426	Fifth Wheel Bracket Kit (2004-2011 Ford F-150 New Body Style) (4 & 10 - Bolt Design)
58432	Fifth Wheel Bracket Kit (2002-2008 Dodge RAM 1500 Pickup, Except Mega Cab) (4 - Bolt Design)
58433	Fifth Wheel Bracket Kit (2009-2012 Dodge RAM 1500 Pickup, Except Models w/Dual Exhaust & Crew Cab) (4 - Bolt Design)

Note: Will not fit trucks with beds shorter than 6' in length unless used with Sidewinder™. Will not fit trucks with flareside/stepside.
 *Bracket kit (#58023) recommended when installing on 02-08 Dodge Ram 1500 pickups.

REESE® ELITE FIFTH WHEEL RAIL KITS

MAKE/MODEL		YEAR	FN	RAIL KIT RS#	
Chevrolet					
Pickup, C/K Series	6 ft. Bed (Old Body Style)	88-00		30063	
	8 ft. Bed (Old Body Style)	88-00		30063	
Pickup, Silverado	1500 HD 6.6 ft. Bed, 2 & 4 WD	01-02	Ø	30061	
	1500 HD 6.6 ft. Bed, 2 & 4 WD	03-06	Ø	30061	
	1500 HD 6.6 ft. Bed, 2 & 4 WD (Classic)	2007	Ø	30061	
	1500 LD 5.8 ft. Bed, 2 & 4 WD	04-06	Ø,SW	30061	
	1500 LD 5.8 ft. Bed, 2 & 4 WD (Classic)	2007	Ø,SW	30061	
	1500 LD 6.6 ft. Bed, 2 & 4 WD	99-02	Ø	30061	
	1500 LD 6.6 ft. Bed, 2 & 4 WD	03-06	Ø	30061	
	1500 LD 6.6 ft. Bed, 2 & 4 WD (Classic)	2007	Ø	30061	
	1500 LD 8 ft. Bed, 2 & 4 WD	99-02		30060	
	1500 LD 8 ft. Bed, 2 & 4 WD	03-06		30060	
	1500 LD 8 ft. Bed, 2 & 4 WD (Classic)	2007		30060	
	2500 HD 6.6 ft. Bed, 2 & 4 WD	01-02	Ø	30061	
	2500 HD 6.6 ft. Bed, 2 & 4 WD	03-06	Ø	30061	
	2500 HD 6.6 ft. Bed, 2 & 4 WD (New Body Style)	07-10		30061	
	2500 HD 6.6 ft. Bed, 2 & 4 WD (New Body Style)	11-12	Ø	30868	
	2500 HD 8 ft. Bed, 2 & 4 WD	01-02		30060	
				Ø	30082
	2500 HD 8 ft. Bed, 2 & 4 WD	03-06		30060	
				Ø	30082
	2500 HD 8 ft. Bed, 2 & 4 WD (Classic)	2007		30060	
				Ø	30082
	2500 HD 8 ft. Bed, 2 & 4 WD (New Body Style)	07-10		30082	
	2500 HD 8 ft. Bed, 2 & 4 WD (New Body Style)	11-12	Ø	30868	
	2500 LD 6.6 ft. Bed, 2 & 4 WD	99-02	Ø	30061	
	2500 LD 6.6 ft. Bed, 2 & 4 WD	03-04	Ø	30061	
	2500 LD 8 ft. Bed, 2 & 4 WD	99-02		30060	
2500 LD 8 ft. Bed, 2 & 4 WD	03-04		30060		
3500 HD 6.6 ft. Bed, 2 & 4 WD (New Body Style)	07-10		30061		
3500 HD 6.6 ft. Bed, 2 & 4 WD (New Body Style)	11-12	Ø	30868		
3500 HD 8 ft. Bed, 2 & 4 WD (New Body Style)	07-10		30082		
3500 HD 8 ft. Bed, 2 & 4 WD (New Body Style)	11-12	Ø	30868		
3500 Series 8 ft. Bed, 2 & 4 WD	01-02		30062		
			Ø	30082	
3500 Series 8 ft. Bed, 2 & 4 WD	03-06		30062		
			Ø	30082	
3500 Series 8 ft. Bed, 2 & 4 WD (Classic)	2007		30062		
			Ø	30082	
Dodge					
Pickup, Ram, Full Size		94-01		30069	
	1500 Only, Except Mega Cab	02-08		30067	
	1500, Inc. Mega Cab	02-08	Ø	30074	
	2500 HD, Except Mega Cab	03-09		30067	
	2500 HD, Except Mega Cab	2010		30067	
	2500 HD, Inc. Mega Cab, 2 & 4 WD	03-09	Ø	30074	

REESE® ELITE FIFTH WHEEL RAIL KITS

MAKE/MODEL		YEAR	FN	RAIL KIT RS#
Dodge (Continued)				
Pickup, Ram, Full Size (Continued)	2500 HD, Inc. Mega Cab, 2 & 4 WD	10-11	Ø	30074
			Ø	30852
	2500 Only, All Models	2002		30069
	3500 HD, Except Mega Cab	03-09		30067
	3500 HD, Except Mega Cab	2010		30067
	3500 HD, Inc. Mega Cab & Dually, 2 & 4 WD	03-09	Ø	30074
	3500 HD, Inc. Mega Cab & Dually, 2 & 4 WD	10-11	Ø	30074
			Ø	30852
	3500 Only, All Models	2002		30069
Ford				
F-150	New Body Style, Regular Cab w/6.5 & 8 ft. Beds	04-08		30064
	New Body Style, Regular Cab w/6.5 & 8 ft. Beds	09-11		30064
	New Body Style, SuperCab w/5.5, 6.5 & 8 ft. Beds	04-08	SW	30064
	New Body Style, SuperCab w/5.5, 6.5 & 8 ft. Beds	09-11	SW	30064
F-150 SuperCrew	New Body Style, w/5.5 & 6.5 ft. Beds	04-08	SW	30064
	New Body Style, w/5.5 & 6.5 ft. Beds	09-11	SW	30064
F-250 Super Duty	Pickups Only - Will Not Fit Cab & Chassis	99-01		30073
	Pickups Only - Will Not Fit Cab & Chassis	02-04		30073
	Pickups Only - Will Not Fit Cab & Chassis	05-07		30073
	Pickups Only - Will Not Fit Cab & Chassis	08-10		30073
	Pickups Only - Will Not Fit Cab & Chassis	11-12	Ø	30126
F-350 Super Duty	Pickups Only - Will Not Fit Cab & Chassis	99-01		30073
	Pickups Only - Will Not Fit Cab & Chassis	02-04		30073
	Pickups Only - Will Not Fit Cab & Chassis	05-07		30073
	Pickups Only - Will Not Fit Cab & Chassis	08-10		30073
	Pickups Only - Will Not Fit Cab & Chassis	11-12	Ø	30126
F-450 Super Duty	Pickups Only - Will Not Fit Cab & Chassis	08-10		30073
	Pickups Only - Will Not Fit Cab & Chassis	11-12	Ø	30126
GMC				
Pickup, C/K Series	6 ft. Bed (Old Body Style)	88-00		30063
	8 ft. Bed (Old Body Style)	88-00		30063
Pickup, Sierra	1500 HD 6.6 ft. Bed, 2 & 4 WD	01-02	Ø	30061
	1500 HD 6.6 ft. Bed, 2 & 4 WD	03-06	Ø	30061
	1500 HD 6.6 ft. Bed, 2 & 4 WD (Classic)	2007	Ø	30061
	1500 LD 5.8 ft. Bed, 2 & 4 WD	04-06	Ø,SW	30061
	1500 LD 5.8 ft. Bed, 2 & 4 WD (Classic)	2007	Ø,SW	30061
	1500 LD 6.6 ft. Bed, 2 & 4 WD	99-02	Ø	30061
	1500 LD 6.6 ft. Bed, 2 & 4 WD	03-06	Ø	30061
	1500 LD 6.6 ft. Bed, 2 & 4 WD (Classic)	2007	Ø	30061
	1500 LD 8 ft. Bed, 2 & 4 WD	99-02		30060
	1500 LD 8 ft. Bed, 2 & 4 WD	03-06		30060
	1500 LD 8 ft. Bed, 2 & 4 WD (Classic)	2007		30060
	2500 HD 6.6 ft. Bed, 2 & 4 WD	01-02	Ø	30061
	2500 HD 6.6 ft. Bed, 2 & 4 WD	03-06	Ø	30061
	2500 HD 6.6 ft. Bed, 2 & 4 WD (New Body Style)	07-10		30061
2500 HD 6.6 ft. Bed, 2 & 4 WD (New Body Style)	11-12	Ø	30868	

REESE® ELITE FIFTH WHEEL RAIL KITS

MAKE/MODEL		YEAR	FN	RAIL KIT RS #
GMC (Continued)				
Pickup, Sierra (Continued)	2500 HD 8 ft. Bed, 2 & 4 WD	01-02		30060
			Ø	30082
	2500 HD 8 ft. Bed, 2 & 4 WD	03-06		30060
			Ø	30082
	2500 HD 8 ft. Bed, 2 & 4 WD (Classic)	2007		30060
			Ø	30082
	2500 HD 8 ft. Bed, 2 & 4 WD (New Body Style)	07-10		30082
	2500 HD 8 ft. Bed, 2 & 4 WD (New Body Style)	11-12	Ø	30868
	2500 LD 6.6 ft. Bed, 2 & 4 WD	99-02	Ø	30061
	2500 LD 6.6 ft. Bed, 2 & 4 WD	03-04	Ø	30061
	2500 LD 8 ft. Bed, 2 & 4 WD	99-02		30060
	2500 LD 8 ft. Bed, 2 & 4 WD	03-04		30060
	3500 HD 6.6 ft. Bed, 2 & 4 WD (New Body Style)	07-10		30061
	3500 HD 6.6 ft. Bed, 2 & 4 WD (New Body Style)	11-12	Ø	30868
	3500 HD 8 ft. Bed, 2 & 4 WD (New Body Style)	07-10		30082
	3500 HD 8 ft. Bed, 2 & 4 WD (New Body Style)	11-12	Ø	30868
	3500 Series 8 ft. Bed, 2 & 4 WD	01-02		30062
			Ø	30082
	3500 Series 8 ft. Bed, 2 & 4 WD	03-06		30062
			Ø	30082
	3500 Series 8 ft. Bed, 2 & 4 WD (Classic)	2007		30062
			Ø	30082
	Denali HD 6.6 ft. Bed, 2 & 4 WD (New Body Style)	11-12	Ø	30868
Toyota				
Tundra	w/Regular Cab & Long Bed Only	00-02	Ø	30078
	w/Regular Cab & Long Bed Only	03-06	Ø	30078

SW = Do not install on a truck with less than a 6' long bed unless the trailer is equipped with a Sidewinder pinbox coupler #SW16K or #SW19K.
Ø = No Drill

ACCESSORY PARTS

Part No.	Description
30149	Elite™ Series Rail Kit Accessory, Plastic Bedliner Puck Adapter Kit (includes: (4) Pucks & (4) Spacers)
58458	Replacement part, trim rings (for GM and Dodge Elite™ Rail Kits)

FIFTH WHEEL CUSTOM QUICK INSTALL BRACKET & COMPLETE KIT APPLICATION GUIDE

MAKE	MODEL	STYLE	YEAR	PART NO.	10-BOLT KIT	4-BOLT KIT	NO DRILL
Chevrolet							
Pickup, Silverado	1500 HD	6.6 ft. Bed, 2 & 4 WD	01-02	50064	50064-58	50064-24	X
Pickup, Silverado	1500 HD	6.6 ft. Bed, 2 & 4 WD	03-06	50064	50064-58	50064-24	X
Pickup, Silverado	1500 HD	6.6 ft. Bed, 2 & 4 WD (Classic)	2007	50064	50064-58	50064-24	X
Pickup, Silverado	1500 LD	5.8 ft. Bed, 2 & 4 WD	04-06	50064	50064-58	50064-24	X
Pickup, Silverado	1500 LD	5.8 ft. Bed, 2 & 4 WD (Classic)	2007	50064	50064-58	50064-24	X
Pickup, Silverado	1500 LD	5.8 ft. Bed, 2 & 4 WD (New Body Style)	07-12	50064	50064-58	50064-24	X
Pickup, Silverado	1500 LD	6.6 ft. Bed, 2 & 4 WD	99-02	50064	50064-58	50064-24	X
Pickup, Silverado	1500 LD	6.6 ft. Bed, 2 & 4 WD	03-06	50064	50064-58	50064-24	X
Pickup, Silverado	1500 LD	6.6 ft. Bed, 2 & 4 WD (Classic)	2007	50064	50064-58	50064-24	X
Pickup, Silverado	1500 LD	6.6 ft. Bed, 2 & 4 WD (New Body Style)	07-12	50064	50064-58	50064-24	X
Pickup, Silverado	1500 LD	8 ft. Bed, 2 & 4 WD	99-02	50064	50064-58	50064-24	X
Pickup, Silverado	1500 LD	8 ft. Bed, 2 & 4 WD	03-06	50064	50064-58	50064-24	X
Pickup, Silverado	1500 LD	8 ft. Bed, 2 & 4 WD (Classic)	2007	50064	50064-58	50064-24	X
Pickup, Silverado	1500 LD	8 ft. Bed, 2 & 4 WD (New Body Style)	07-12	50064	50064-58	50064-24	X
Pickup, Silverado	2500 HD	6.6 ft. Bed, 2 & 4 WD	01-02	50064	50064-58	50064-24	X
Pickup, Silverado	2500 HD	6.6 ft. Bed, 2 & 4 WD	03-06	50064	50064-58	50064-24	X
Pickup, Silverado	2500 HD	6.6 ft. Bed, 2 & 4 WD (Classic)	2007	50064	50064-58	50064-24	X
Pickup, Silverado	2500 HD	6.6 ft. Bed, 2 & 4 WD (New Body Style)	07-10	50064	50064-58	50064-24	X
Pickup, Silverado	2500 HD	6.6 ft. Bed, 2 & 4 WD (New Body Style)	11-12	50066	50066-58	50066-24	X
				56001	56001-53		X
Pickup, Silverado	2500 HD	8 ft. Bed, 2 & 4 WD	01-02	50064	50064-58	50064-24	X
Pickup, Silverado	2500 HD	8 ft. Bed, 2 & 4 WD	03-06	50064	50064-58	50064-24	X
Pickup, Silverado	2500 HD	8 ft. Bed, 2 & 4 WD (Classic)	2007	50064	50064-58	50064-24	X
Pickup, Silverado	2500 HD	8 ft. Bed, 2 & 4 WD (New Body Style)	07-10	50064	50064-58	50064-24	X
Pickup, Silverado	2500 HD	8 ft. Bed, 2 & 4 WD (New Body Style)	11-12	50066	50066-58	50066-24	X
				56001	56001-53		X
Pickup, Silverado	2500 LD	6.6 ft. Bed, 2 & 4 WD	99-02	50064	50064-58	50064-24	X
Pickup, Silverado	2500 LD	6.6 ft. Bed, 2 & 4 WD	03-04	50064	50064-58	50064-24	X
Pickup, Silverado	2500 LD	8 ft. Bed, 2 & 4 WD	99-02	50064	50064-58	50064-24	X
Pickup, Silverado	2500 LD	8 ft. Bed, 2 & 4 WD	03-04	50064	50064-58	50064-24	X
Pickup, Silverado	3500 HD	6.6 ft. Bed, 2 & 4 WD (New Body Style)	07-10	50064	50064-58	50064-24	X
Pickup, Silverado	3500 HD	6.6 ft. Bed, 2 & 4 WD (New Body Style)	11-12	50066	50066-58	50066-24	X
				56001	56001-53		X
Pickup, Silverado	3500 HD	8 ft. Bed, 2 & 4 WD (New Body Style)	07-10	50064	50064-58	50064-24	X
Pickup, Silverado	3500 HD	8 ft. Bed, 2 & 4 WD (New Body Style)	11-12	50066	50066-58	50066-24	X
				56001	56001-53		X
Pickup, Silverado	3500 Series	8 ft. Bed, 2 & 4 WD	01-02	50064	50064-58	50064-24	X
Pickup, Silverado	3500 Series	8 ft. Bed, 2 & 4 WD	03-06	50064	50064-58	50064-24	X
Pickup, Silverado	3500 Series	8 ft. Bed, 2 & 4 WD (Classic)	2007	50064	50064-58	50064-24	X

FIFTH WHEEL CUSTOM QUICK INSTALL BRACKET & COMPLETE KIT APPLICATION GUIDE

MAKE	MODEL	STYLE	YEAR	PART NO.	10-BOLT KIT	4-BOLT KIT	NO DRILL
Dodge							
Pickup, Ram, Full Size 1500 Mega Cab w/6 ft. Bed, 2 & 4 WD			06-08	50140	50140-58	50140-24	X
Pickup, Ram, Full Size 1500 Only, 2 & 4 WD, Except Mega Cab			02-08	50040	50040-58		X
Pickup, Ram, Full Size 1500 Quad Cab w/6.4 ft. Bed, 2 & 4 WD			2009	50083	50083-58	50083-24	X
Pickup, Ram, Full Size 1500 Quad Cab w/6.4 ft. Bed, 2 & 4 WD			10-12	50083	50083-58	50083-24	X
Pickup, Ram, Full Size 1500 Regular Cab w/6.4 ft. Bed, 2 & 4 WD			2009	50083	50083-58	50083-24	X
Pickup, Ram, Full Size 1500 Regular Cab w/6.4 ft. Bed, 2 & 4 WD			10-12	50083	50083-58	50083-24	X
Pickup, Ram, Full Size 1500 Regular Cab w/8 ft. Bed, 2 & 4 WD			2009	50083	50083-58	50083-24	X
Pickup, Ram, Full Size 1500 Regular Cab w/8 ft. Bed, 2 & 4 WD			10-12	50083	50083-58	50083-24	X
Pickup, Ram, Full Size 2500 HD, 2 & 4 WD, Except Mega Cab & Models w/Overload Springs			03-09	50040	50040-58		X
Pickup, Ram, Full Size 2500 HD, 2 & 4 WD, Except Mega Cab & Models w/Overload Springs			10-11	50040	50040-58		X
Pickup, Ram, Full Size 2500 HD, Inc. Mega Cab, 2 & 4 WD			03-09	50140	50140-58	50140-24	X
Pickup, Ram, Full Size 2500 HD, Inc. Mega Cab, 2 & 4 WD, Except Models w/Gas Engines w/Overload Springs			10-11	50140	50140-58	50140-24	X
Pickup, Ram, Full Size 3500 HD, 2 & 4 WD, Except Mega Cab & Models w/Overload Springs			03-09	50040	50040-58		X
Pickup, Ram, Full Size 3500 HD, 2 & 4 WD, Except Mega Cab & Models w/Overload Springs			10-11	50040	50040-58		X
Pickup, Ram, Full Size 3500 HD, Inc. Mega Cab & Dually, 2 & 4 WD			03-09	50140	50140-58	50140-24	X
Pickup, Ram, Full Size 3500 HD, Inc. Mega Cab & Dually, 2 & 4 WD, Except Models w/Gas Engines w/Overload Springs			10-11	50140	50140-58	50140-24	X
Ford							
F-150 New Body Style, Regular Cab w/6.5 & 8 ft. Beds			04-08	50081	50081-58	50081-24	X
F-150 New Body Style, Regular Cab w/6.5 & 8 ft. Beds			09-11	50081	50081-58	50081-24	X
F-150 New Body Style, SuperCab w/5.5, 6.5 & 8 ft. Beds			04-08	50081	50081-58	50081-24	X
F-150 New Body Style, SuperCab w/5.5, 6.5 & 8 ft. Beds			09-11	50081	50081-58	50081-24	X
F-150 Light Duty Styleside			97-03	50042	50042-58		X
F-150 Light Duty Heritage Styleside (Old Body Style)			2004	50042	50042-58		X
F-150 SuperCrew New Body Style, w/5.5 & 6.5 ft. Beds			04-08	50081	50081-58	50081-24	X
F-150 SuperCrew New Body Style, w/5.5 & 6.5 ft. Beds			09-11	50081	50081-58	50081-24	X
F-250 Light Duty Styleside			97-99	50042	50042-58		X
F-250 Super Duty Pickups Only - Will Not Fit Cab & Chassis			99-01	50043	50043-58		
				50082	50082-58	50082-24	X
F-250 Super Duty Pickups Only - Will Not Fit Cab & Chassis			02-04	50043	50043-58		
				50082	50082-58	50082-24	X
F-250 Super Duty Pickups Only - Will Not Fit Cab & Chassis			05-07	50082	50082-58	50082-24	X
F-250 Super Duty Pickups Only - Will Not Fit Cab & Chassis			08-10	50082	50082-58	50082-24	X
F-250 Super Duty Pickups Only - Will Not Fit Cab & Chassis			11-12	50073	50073-58	50073-24	X
				56002	56002-53		X
F-350 Super Duty Pickups Only - Will Not Fit Cab & Chassis			99-01	50043	50043-58		
				50082	50082-58	50082-24	X
F-350 Super Duty Pickups Only - Will Not Fit Cab & Chassis			02-04	50043	50043-58		
				50082	50082-58	50082-24	X

FIFTH WHEEL CUSTOM QUICK INSTALL BRACKET & COMPLETE KIT APPLICATION GUIDE

MAKE	MODEL	STYLE	YEAR	PART NO.	10-BOLT KIT	4-BOLT KIT	NO DRILL
Ford (Continued)							
F-350 Super Duty Pickups Only - Will Not Fit Cab & Chassis			05-07	50082	50082-58	50082-24	X
F-350 Super Duty Pickups Only - Will Not Fit Cab & Chassis			08-10	50082	50082-58	50082-24	X
F-350 Super Duty Pickups Only - Will Not Fit Cab & Chassis			11-12	50073	50073-58	50073-24	X
				56002	56002-53		X
F-450 Super Duty Pickups Only - Will Not Fit Cab & Chassis			08-10	50082	50082-58	50082-24	X
F-450 Super Duty Pickups Only - Will Not Fit Cab & Chassis			11-12	50073	50073-58	50073-24	X
				56002	56002-53		X
GMC							
Pickup, Sierra 1500 HD 6.6 ft. Bed, 2 & 4 WD			01-02	50064	50064-58	50064-24	X
Pickup, Sierra 1500 HD 6.6 ft. Bed, 2 & 4 WD			03-06	50064	50064-58	50064-24	X
Pickup, Sierra 1500 HD 6.6 ft. Bed, 2 & 4 WD (Classic)			2007	50064	50064-58	50064-24	X
Pickup, Sierra 1500 LD 5.8 ft. Bed, 2 & 4 WD			04-06	50064	50064-58	50064-24	X
Pickup, Sierra 1500 LD 5.8 ft. Bed, 2 & 4 WD (Classic)			2007	50064	50064-58	50064-24	X
Pickup, Sierra 1500 LD 5.8 ft. Bed, 2 & 4 WD (New Body Style)			07-12	50064	50064-58	50064-24	X
Pickup, Sierra 1500 LD 6.6 ft. Bed, 2 & 4 WD			99-02	50064	50064-58	50064-24	X
Pickup, Sierra 1500 LD 6.6 ft. Bed, 2 & 4 WD			03-06	50064	50064-58	50064-24	X
Pickup, Sierra 1500 LD 6.6 ft. Bed, 2 & 4 WD (Classic)			2007	50064	50064-58	50064-24	X
Pickup, Sierra 1500 LD 6.6 ft. Bed, 2 & 4 WD (New Body Style)			07-12	50064	50064-58	50064-24	X
Pickup, Sierra 1500 LD 8 ft. Bed, 2 & 4 WD			99-02	50064	50064-58	50064-24	X
Pickup, Sierra 1500 LD 8 ft. Bed, 2 & 4 WD			03-06	50064	50064-58	50064-24	X
Pickup, Sierra 1500 LD 8 ft. Bed, 2 & 4 WD (Classic)			2007	50064	50064-58	50064-24	X
Pickup, Sierra 1500 LD 8 ft. Bed, 2 & 4 WD (New Body Style)			07-12	50064	50064-58	50064-24	X
Pickup, Sierra 2500 HD 6.6 ft. Bed, 2 & 4 WD			01-02	50064	50064-58	50064-24	X
Pickup, Sierra 2500 HD 6.6 ft. Bed, 2 & 4 WD			03-06	50064	50064-58	50064-24	X
Pickup, Sierra 2500 HD 6.6 ft. Bed, 2 & 4 WD (Classic)			2007	50064	50064-58	50064-24	X
Pickup, Sierra 2500 HD 6.6 ft. Bed, 2 & 4 WD (New Body Style)			07-10	50064	50064-58	50064-24	X
Pickup, Sierra 2500 HD 6.6 ft. Bed, 2 & 4 WD (New Body Style)			11-12	50066	50066-58	50066-24	X
				56001	56001-53		X
Pickup, Sierra 2500 HD 8 ft. Bed, 2 & 4 WD			01-02	50064	50064-58	50064-24	X
Pickup, Sierra 2500 HD 8 ft. Bed, 2 & 4 WD			03-06	50064	50064-58	50064-24	X
Pickup, Sierra 2500 HD 8 ft. Bed, 2 & 4 WD (Classic)			2007	50064	50064-58	50064-24	X
Pickup, Sierra 2500 HD 8 ft. Bed, 2 & 4 WD (New Body Style)			07-10	50064	50064-58	50064-24	X
Pickup, Sierra 2500 HD 8 ft. Bed, 2 & 4 WD (New Body Style)			11-12	50066	50066-58	50066-24	X
				56001	56001-53		X
Pickup, Sierra 2500 LD 6.6 ft. Bed, 2 & 4 WD			99-02	50064	50064-58	50064-24	X
Pickup, Sierra 2500 LD 6.6 ft. Bed, 2 & 4 WD			03-04	50064	50064-58	50064-24	X
Pickup, Sierra 2500 LD 8 ft. Bed, 2 & 4 WD			99-02	50064	50064-58	50064-24	X
Pickup, Sierra 2500 LD 8 ft. Bed, 2 & 4 WD			03-04	50064	50064-58	50064-24	X
Pickup, Sierra 3500 HD 6.6 ft. Bed, 2 & 4 WD (New Body Style)			07-10	50064	50064-58	50064-24	X
Pickup, Sierra 3500 HD 6.6 ft. Bed, 2 & 4 WD (New Body Style)			11-12	50066	50066-58	50066-24	X
				56001	56001-53		X

MAKE	MODEL	STYLE	YEAR	PART NO.	10-BOLT KIT	4-BOLT KIT	NO DRILL
GMC (Continued)							
Pickup, Sierra 3500 HD 8 ft. Bed, 2 & 4 WD (New Body Style)			07-10	50064	50064-58	50064-24	X
Pickup, Sierra 3500 HD 8 ft. Bed, 2 & 4 WD (New Body Style)			11-12	50066	50066-58	50066-24	X
				56001	56001-53		X
Pickup, Sierra 3500 Series 8 ft. Bed, 2 & 4 WD			01-02	50064	50064-58	50064-24	X
Pickup, Sierra 3500 Series 8 ft. Bed, 2 & 4 WD			03-06	50064	50064-58	50064-24	X
Pickup, Sierra 3500 Series 8 ft. Bed, 2 & 4 WD (Classic)			2007	50064	50064-58	50064-24	X
Pickup, Sierra Denali HD 6.6 ft. Bed, 2 & 4 WD (New Body Style)			11-12	50066	50066-58	50066-24	X
				56001	56001-53		X
Toyota							
Tundra w/Regular Cab & Long Bed Only			00-02	50059	50059-58		X
Tundra w/Regular Cab & Long Bed Only			03-06	50059	50059-58		X

Note: Will not fit trucks with beds shorter than 6' in length unless used with Sidewinder. Will not fit trucks with flareside/stepsides.

UNIVERSAL FIFTH WHEEL RAIL KIT & ADAPTER BRACKET APPLICATION GUIDE

MAKE/MODEL	YEAR	(10 BOLT) RAIL KIT	REQUIRED UPGRADE KIT	(4 BOLT) RAIL KIT	REQUIRED UPGRADE KIT
CHEVROLET					
Pickup, C/K Series 6.5 ft. Bed (Old Body Style)	73-87	30035		30095	
Pickup, C/K Series 6.5 ft. Bed (Old Body Style)	88-00	30035		30095	
Pickup, C/K Series 8 ft. Bed (Old Body Style)	73-87	30035		30095	
Pickup, C/K Series 8 ft. Bed (Old Body Style)	88-00	30035		30095	
Pickup, C/K Series Crew Cab (Old Body Style)	92-00	30035		30095	
Pickup, Silverado 1500 HD 6.6 ft. Bed, 2 & 4 WD	01-06	30035		30095	
Pickup, Silverado 1500 HD 6.6 ft. Bed, 2 & 4 WD (Classic)	2007	30035		30095	
Pickup, Silverado 1500 LD 5.8 ft. Bed, 2 & 4 WD	04-06	30035		30095	
Pickup, Silverado 1500 LD 5.8 ft. Bed, 2 & 4 WD (Classic)	2007	30035		30095	
Pickup, Silverado 1500 LD 5.8 ft. Bed, 2 & 4 WD (New Body Style)	07-12	30035		30095	
Pickup, Silverado 1500 LD 6.6 ft. Bed, 2 & 4 WD	99-06	30035		30095	
Pickup, Silverado 1500 LD 6.6 ft. Bed, 2 & 4 WD (Classic)	2007	30035		30095	
Pickup, Silverado 1500 LD 6.6 ft. Bed, 2 & 4 WD (New Body Style)	07-12	30035		30095	
Pickup, Silverado 1500 LD 8 ft. Bed, 2 & 4 WD	99-06	30035		30095	
Pickup, Silverado 1500 LD 8 ft. Bed, 2 & 4 WD (Classic)	2007	30035		30095	
Pickup, Silverado 1500 LD 8 ft. Bed, 2 & 4 WD (New Body Style)	07-12	30035		30095	
Pickup, Silverado 2500 HD 6.6 ft. Bed, 2 & 4 WD	01-06	30035		30095	
Pickup, Silverado 2500 HD 6.6 ft. Bed, 2 & 4 WD (Classic)	2007	30035		30095	
Pickup, Silverado 2500 HD 6.6 ft. Bed, 2 & 4 WD (New Body Style)	07-10	30035		30095	
Pickup, Silverado 2500 HD 6.6 ft. Bed, 2 & 4 WD (New Body Style)	11-12	30035		30095	
Pickup, Silverado 2500 HD 8 ft. Bed, 2 & 4 WD	01-06	30035		30095	
Pickup, Silverado 2500 HD 8 ft. Bed, 2 & 4 WD (Classic)	2007	30035		30095	
Pickup, Silverado 2500 HD 8 ft. Bed, 2 & 4 WD (New Body Style)	07-10	30035		30095	
Pickup, Silverado 2500 HD 8 ft. Bed, 2 & 4 WD (New Body Style)	11-12	30035		30095	
Pickup, Silverado 2500 LD 6.6 ft. Bed, 2 & 4 WD	99-04	30035		30095	
Pickup, Silverado 2500 LD 8 ft. Bed, 2 & 4 WD	99-04	30035		30095	
Pickup, Silverado 3500 HD 6.6 ft. Bed, 2 & 4 WD (New Body Style)	07-10	30035		30095	
Pickup, Silverado 3500 HD 6.6 ft. Bed, 2 & 4 WD (New Body Style)	11-12	30035		30095	
Pickup, Silverado 3500 HD 8 ft. Bed, 2 & 4 WD (New Body Style)	07-10	30035		30095	
Pickup, Silverado 3500 HD 8 ft. Bed, 2 & 4 WD (New Body Style)	11-12	30035		30095	
Pickup, Silverado 3500 Series 8 ft. Bed, 2 & 4 WD	01-06	30035		30095	
Pickup, Silverado 3500 Series 8 ft. Bed, 2 & 4 WD (Classic)	2007	30035		30095	
DODGE					
Dakota Pickup	94-04	30035			
Pickup, D/W Series, Full Size 100	73-89	30035		30095	
Pickup, D/W Series, Full Size 150	77-93	30035		30095	
Pickup, D/W Series, Full Size 200	73-80	30035		30095	
Pickup, D/W Series, Full Size 250	81-93	30035		30095	
Pickup, D/W Series, Full Size 300	73-80	30035		30095	
Pickup, D/W Series, Full Size 350	81-93	30035		30095	
Pickup, Ram, Full Size 1500 Crew Cab w/5.7 ft. Bed	10-12	30035	58386		
Pickup, Ram, Full Size 1500 Crew Cab w/5.7 ft. Bed	2009	30035	58386		
Pickup, Ram, Full Size 1500 Only, All Models	00-01	30035		30095	
Pickup, Ram, Full Size 1500 Only, All Models	94-99	30035		30095	
Pickup, Ram, Full Size 1500 Quad Cab w/6.4 ft. Bed, 2 & 4 WD	10-12	30035	58386	30095	58433
Pickup, Ram, Full Size 1500 Quad Cab w/6.4 ft. Bed, 2 & 4 WD	2009	30035	58386	30095	58433
Pickup, Ram, Full Size 1500 Regular Cab w/6.4 ft. Bed, 2 & 4 WD	10-12	30035	58386	30095	58433
Pickup, Ram, Full Size 1500 Regular Cab w/6.4 ft. Bed, 2 & 4 WD	2009	30035	58386	30095	58433

UNIVERSAL FIFTH WHEEL RAIL KIT & ADAPTER BRACKET APPLICATION GUIDE

MAKE/MODEL	YEAR	(10 BOLT) RAIL KIT	REQUIRED UPGRADE KIT	(4 BOLT) RAIL KIT	REQUIRED UPGRADE KIT
DODGE (Continued)					
Pickup, Ram, Full Size 1500 Regular Cab w/8 ft. Bed, 2 & 4 WD	10-12	30035	58386	30095	58433
Pickup, Ram, Full Size 1500 Regular Cab w/8 ft. Bed, 2 & 4 WD	2009	30035	58386	30095	58433
Pickup, Ram, Full Size 1500, Inc. Mega Cab	02-08	30035			
Pickup, Ram, Full Size 2500 HD with Overload Springs	03-09	30035	58186		
Pickup, Ram, Full Size 2500 HD with Overload Springs	10-11	30035	58186		
Pickup, Ram, Full Size 2500 HD without Overload Springs	03-09	30035		30095	
Pickup, Ram, Full Size 2500 HD without Overload Springs	10-11	30035		30095	
Pickup, Ram, Full Size 2500 Only, All Models	00-02	30035		30095	
Pickup, Ram, Full Size 2500 Only, All Models	94-99	30035		30095	
Pickup, Ram, Full Size 3500 HD with Overload Springs	03-09	30035	58186		
Pickup, Ram, Full Size 3500 HD with Overload Springs	10-11	30035	58186		
Pickup, Ram, Full Size 3500 HD without Overload Springs	03-09	30035		30095	
Pickup, Ram, Full Size 3500 HD without Overload Springs	10-11	30035		30095	
Pickup, Ram, Full Size 3500 Only, All Models	00-02	30035		30095	
Pickup, Ram, Full Size 3500 Only, All Models	94-99	30035		30095	
FORD					
F-100	73-79	30035		30095	
F-100	80-83	30035		30095	
F-150	75-79	30035		30095	
F-150	80-96	30035		30095	
F-150 New Body Style, Regular Cab w/6.5 & 8 ft. Beds	04-08	30035	58426	30095	58426
F-150 New Body Style, Regular Cab w/6.5 & 8 ft. Beds	09-11	30035	58426	30095	58426
F-150 New Body Style, SuperCab w/5.5, 6.5 & 8 ft. Beds	04-08	30035	58426	30095	58426
F-150 New Body Style, SuperCab w/5.5, 6.5 & 8 ft. Beds	09-11	30035	58426	30095	58426
F-150 Light Duty Styleside, Except SuperCrew	97-03	30035		30095	
F-150 Light Duty Heritage Styleside (Old Body Style)	2004	30035		30095	
F-150 SuperCrew New Body Style, w/5.5 & 6.5 ft. Beds	04-08	30035	58426	30095	58426
F-150 SuperCrew New Body Style, w/5.5 & 6.5 ft. Beds	09-11	30035	58426	30095	58426
F-250	73-79	30035		30095	
F-250	80-96	30035		30095	
F-250 Heavy Duty	1997	30035		30095	
F-250 Light Duty Styleside	97-99	30035		30095	
F-250 Super Duty Pickups Only - Will Not Fit Cab & Chassis	02-04	30035			
F-250 Super Duty Pickups Only - Will Not Fit Cab & Chassis	05-07	30035		30095	58425
F-250 Super Duty Pickups Only - Will Not Fit Cab & Chassis	08-10	30035		30095	58425
F-250 Super Duty Pickups Only - Will Not Fit Cab & Chassis	11-12	30035		30095	58425
F-250 Super Duty Pickups Only - Will Not Fit Cab & Chassis	99-01	30035			
F-350	73-79	30035		30095	
F-350	80-96	30035		30095	
F-350 Heavy Duty	1997	30035		30095	
F-350 Super Duty Pickups Only - Will Not Fit Cab & Chassis	02-04	30035			
F-350 Super Duty Pickups Only - Will Not Fit Cab & Chassis	05-07	30035		30095	58425
F-350 Super Duty Pickups Only - Will Not Fit Cab & Chassis	08-10	30035		30095	58425
F-350 Super Duty Pickups Only - Will Not Fit Cab & Chassis	11-12	30035		30095	58425
F-350 Super Duty Pickups Only - Will Not Fit Cab & Chassis	99-01	30035			
F-450 Super Duty Pickups Only - Will Not Fit Cab & Chassis	08-10	30035		30095	58425
F-450 Super Duty Pickups Only - Will Not Fit Cab & Chassis	11-12	30035		30095	58425

UNIVERSAL FIFTH WHEEL RAIL KIT & ADAPTER BRACKET APPLICATION GUIDE

MAKE/MODEL	YEAR	(10 BOLT) RAIL KIT	REQUIRED UPGRADE KIT	(4 BOLT) RAIL KIT	REQUIRED UPGRADE KIT
GMC					
Pickup, C/K Series 6.5 ft. Bed (Old Body Style)	73-87	30035		30095	
Pickup, C/K Series 6.5 ft. Bed (Old Body Style)	88-00	30035		30095	
Pickup, C/K Series 8 ft. Bed (Old Body Style)	73-87	30035		30095	
Pickup, C/K Series 8 ft. Bed (Old Body Style)	88-00	30035		30095	
Pickup, C/K Series Crew Cab (Old Body Style)	92-00	30035		30095	
Pickup, Sierra 1500 HD 6.6 ft. Bed, 2 & 4 WD	01-06	30035		30095	
Pickup, Sierra 1500 HD 6.6 ft. Bed, 2 & 4 WD (Classic)	2007	30035		30095	
Pickup, Sierra 1500 LD 5.8 ft. Bed, 2 & 4 WD	04-06	30035		30095	
Pickup, Sierra 1500 LD 5.8 ft. Bed, 2 & 4 WD (Classic)	2007	30035		30095	
Pickup, Sierra 1500 LD 5.8 ft. Bed, 2 & 4 WD (New Body Style)	07-12	30035		30095	
Pickup, Sierra 1500 LD 6.6 ft. Bed, 2 & 4 WD	99-06	30035		30095	
Pickup, Sierra 1500 LD 6.6 ft. Bed, 2 & 4 WD (Classic)	2007	30035		30095	
Pickup, Sierra 1500 LD 6.6 ft. Bed, 2 & 4 WD (New Body Style)	07-12	30035		30095	
Pickup, Sierra 1500 LD 8 ft. Bed (Classic)	2007	30035		30095	
Pickup, Sierra 1500 LD 8 ft. Bed, 2 & 4 WD	99-06	30035		30095	
Pickup, Sierra 1500 LD 8 ft. Bed, 2 & 4 WD (New Body Style)	07-12	30035		30095	
Pickup, Sierra 2500 HD 6.6 ft. Bed, 2 & 4 WD	01-06	30035		30095	
Pickup, Sierra 2500 HD 6.6 ft. Bed, 2 & 4 WD (Classic)	2007	30035		30095	
Pickup, Sierra 2500 HD 6.6 ft. Bed, 2 & 4 WD (New Body Style)	07-10	30035		30095	
Pickup, Sierra 2500 HD 6.6 ft. Bed, 2 & 4 WD (New Body Style)	11-12	30035		30095	
Pickup, Sierra 2500 HD 8 ft. Bed, 2 & 4 WD	01-06	30035		30095	
Pickup, Sierra 2500 HD 8 ft. Bed, 2 & 4 WD (Classic)	2007	30035		30095	
Pickup, Sierra 2500 HD 8 ft. Bed, 2 & 4 WD (New Body Style)	07-10	30035		30095	
Pickup, Sierra 2500 HD 8 ft. Bed, 2 & 4 WD (New Body Style)	11-12	30035		30095	
Pickup, Sierra 2500 LD 6.6 ft. Bed, 2 & 4 WD	99-04	30035		30095	
Pickup, Sierra 2500 LD 8 ft. Bed, 2 & 4 WD	99-04	30035		30095	
Pickup, Sierra 3500 HD 6.6 ft. Bed, 2 & 4 WD (New Body Style)	07-10	30035		30095	
Pickup, Sierra 3500 HD 6.6 ft. Bed, 2 & 4 WD (New Body Style)	11-12	30035		30095	
Pickup, Sierra 3500 HD 8 ft. Bed, 2 & 4 WD (New Body Style)	07-10	30035		30095	
Pickup, Sierra 3500 HD 8 ft. Bed, 2 & 4 WD (New Body Style)	11-12	30035		30095	
Pickup, Sierra 3500 Series 8 ft. Bed, 2 & 4 WD	01-06	30035		30095	
Pickup, Sierra 3500 Series 8 ft. Bed, 2 & 4 WD (Classic)	2007	30035		30095	
Pickup, Sierra Denali HD 6.6 ft. Bed, 2 & 4 WD (New Body Style)	11-12	30035		30095	
NISSAN					
Titan Pickup Crew Cab 5.6 ft. Bed	04-11	30035	58405		
Titan Pickup Crew Cab 7.25 ft. Bed	04-11	30035	58405		
Titan Pickup King Cab 6.5 ft. Bed	04-11	30035	58405		
Titan Pickup King Cab 8 ft. Bed	04-11	30035	58405		
TOYOTA					
Tundra Crew Max 5.5 ft. Bed	07-09	30035	58309		
Tundra Crew Max 5.5 ft. Bed	10-12	30035	58309		
Tundra Double Cab 6.5 ft. Bed	07-09	30035	58309		
Tundra Double Cab 6.5 ft. Bed	10-12	30035	58309		
Tundra Double Cab 8 ft. Bed	07-09	30035	58309		
Tundra Double Cab 8 ft. Bed	10-12	30035	58309		
Tundra Regular Cab 6.5 ft. Bed	07-09	30035	58309		
Tundra Regular Cab 6.5 ft. Bed	10-12	30035	58309		
Tundra Regular Cab 8 ft. Bed	07-09	30035	58309		

MAKE/MODEL	YEAR	(10 BOLT) RAIL KIT	REQUIRED UPGRADE KIT	(4 BOLT) RAIL KIT	REQUIRED UPGRADE KIT
TOYOTA (Continued)					
Tundra Regular Cab 8 ft. Bed	10-12	30035	58309		
Tundra w/Regular Cab & Long Bed Only	00-02	30035	58197	30095	
Tundra w/Regular Cab & Long Bed Only	03-06	30035	58197	30095	

Note: Will not fit trucks with beds shorter than 6' in length unless used with Sidewinder. Will not fit trucks with flareside/stepside.

WHY AN EXTENDED PIN BOX

Trucks come in many different configurations. Cequent Performance Products' hitches are designed for use in light trucks such as the Ford F-Series, the Chevy Silverado and the Dodge Ram. Cequent Performance Products recommends the use of long bed (8ft) light trucks for the best combination in truck -trailer turning clearance.

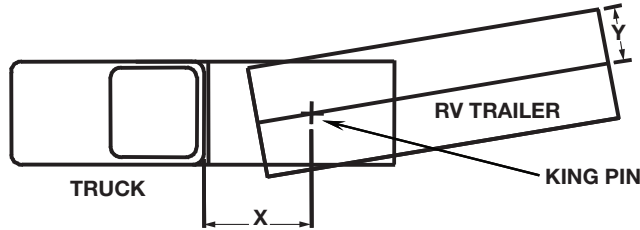

RULE OF THUMB:

The distance from the back of the truck cab to the center of the rear truck axle "X", should be approximately 4 inches greater than one-half the trailer width "Y".

If a short bed pickup (less than 8 ft. but longer than 6 ft.) is to be used for towing, Cequent Performance Products recommends the trailer be equipped with a minimum 13" extended pin box to help gain additional truck -trailer turning clearance (See trailer manufacturer for options) (See below). It also may be helpful for the 18K version to add an Elite series Slider (Part # 30070) for increased turning clearance for low speed, non-highway maneuvering.

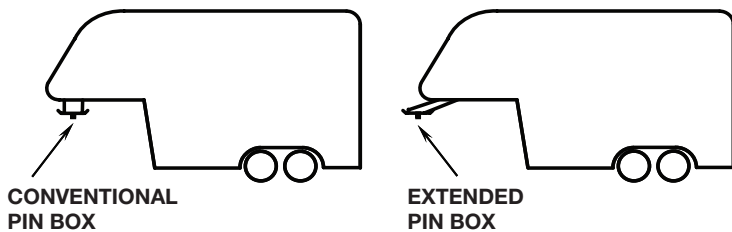

⚠ WARNING:

Do Not install this fifth wheel hitch on or attempt to tow with a short bed pickup truck that has a bed shorter than 6 ft. Unless you use a REESE Sidewinder or Revolution Pin Box. Doing so could result in vehicle damage, Serious injury, or Death.

The height of the hitch and the pin box should be adjusted so the trailer is approximately level as it is towed. Allow approximately 6 inches clearance between the top of the pickup walls and the underside of the front of the trailer for pitch and roll of the trailer. (See below.) For off road use allow more clearance between pickup walls and trailer.

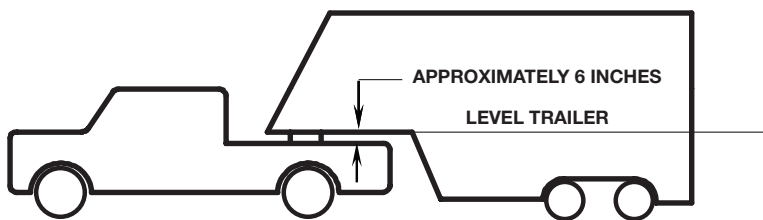

CAUTION:

The measurements above are guidelines. If your measurements are close to those numbers re-check clearances. If vehicle and/or trailer has any added bed vicinity accessories (i.e. fairings, airdams, groundeffects, bedrails, etc.), additional dimensioning and clearance checks have to be made.

PIN BOX DIMENSIONS

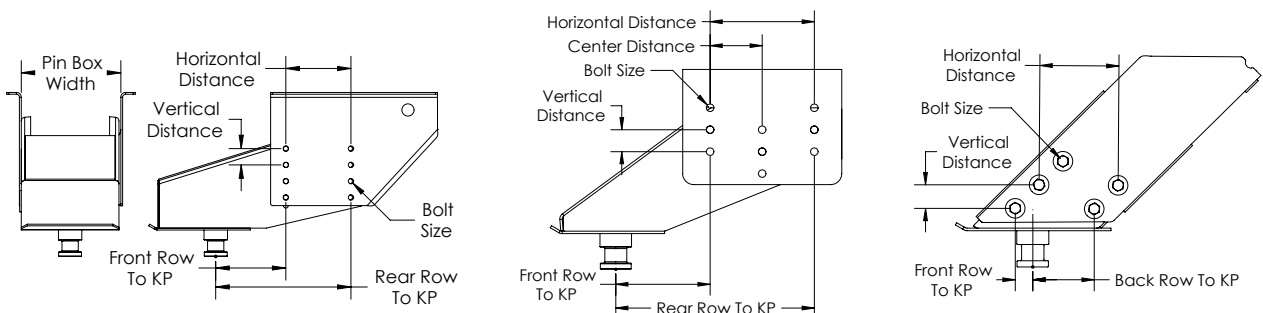

PIN BOXES

GOOSENECK COUPLER FOR RV'S

Goose Box™ Gooseneck Coupler for RV's

PIN BOX CONVERSION

Pin Box Matrix Conversion

PIN BOXES

Reese® Elite Airborne/Sidewinder™

Reese® Airborne/Sidewinder™

Reese® Sidewinder™

Reese® 5th Airborne™

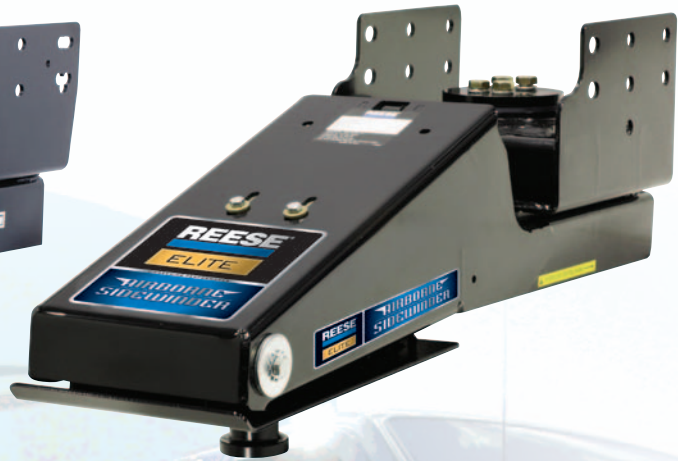



STEP UP TO RV COMFORT AND KEEP YOUR GOOSENECK HITCH!

Take the heavy equipment out of the truck bed! The Goose Box™ gooseneck coupler is specifically designed for RV trailer owners who wish to tow with their gooseneck hitch. The Reese® Goose Box™ replaces a traditional pin box so the RV works with the truck gooseneck hitch. Includes 5th Airborne™ technology for a superb ride.

- World's first OE approved gooseneck adapter, Endorsed by Lippert Components, Inc. for their frame systems
- Fits Lippert #1621 and #1716 wing sets
- 5th Airborne™ expertise reduces stress transferred to the RV frame
- Independent lab tested & proven to provide a better ride than king pin "bolt-on" adapter solutions (Bosch Automotive Proving Grounds)
- Bulldog® gooseneck coupler technology with traditional king pin styling
- Air bag, dual shocks and rubber bumpers provide multi-directional shock absorption for a smoother driving experience
- Air pressure relief valve prevents overfilling of air bags
- Available in bulk or individual packaging
- Rated for 16,000 lb. capacity utilizing both CSA & SAE J2638 test standards
- Limited 7 year warranty



Air Pressure Relief Valve

Part No.	Description
94621	Goose Box™ For Lippert #1621 & #1716 Wing Sets (bulk - minimum order, 3 pcs.)
94622	Goose Box™ For Lippert #1621 & #1716 Wing Sets (carton)

Patent Pending.



SAY YES, TO GOOSE BOX™!

Tests were conducted on a traditional pin box, existing gooseneck extension adapters, and the Goose Box™. The results were conclusive!



"The Goose Box is a great solution for fifth-wheel RV users who prefer to use gooseneck hitches," said Jason Lippert, CEO of Lippert Components. "We are very pleased with the results of the thorough testing of the Goose Box, which demonstrates that it is compatible with our RV frame. As a result, the proper installation of a Goose Box pin box will be acceptable under our RV frame warranty." – Lippert Press Release

After reviewing the Bosch Test reports for the Reese Goose Box™, Lippert Components (the world's largest manufacturer of RV frames) accepts the Goose Box for the towing of RVs with gooseneck hitches. "Proper installation of a Goose Box in its intended application will not void the chassis warranty when installed on a coach either by the OEM or in the aftermarket." – Jarod Lippert, Director of Marketing

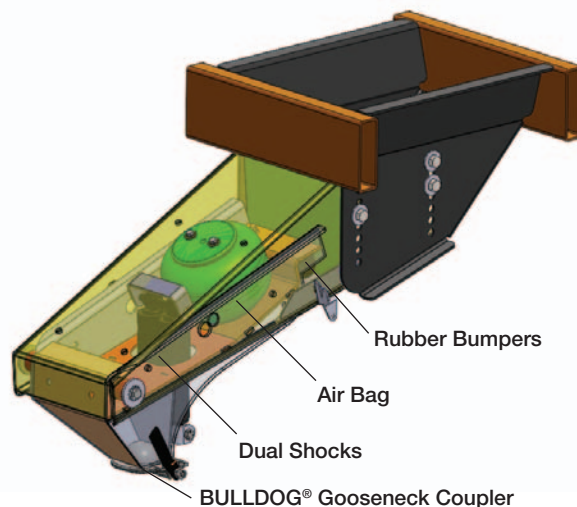

SMOOTHER RIDE, EASIER TURNING

Happier trails,
whatever path you take.



REESE®

Whether you want to smooth out the rough road's impact on your trailer, hassle free 90-plus degree turning, or both, Reese has a fifth wheel pin box to meet your needs. Rely on Reese's innovative design and superior performance to handle whatever challenges you face down the road.*

COMPARE

	5th Airborne™ 16K	5th Airborne™ 21K	Sidewinder™ 16K	Sidewinder™ 19K	Elite Airborne / Sidewinder™ 16K	Airborne / Sidewinder™ 19.5K
Length	17.75 ^{**}	Varies by Model	22"	22"	22"	22"
GVW Capable	16K	21K	16K	19K	16K	19.5K
Air-ride	Yes	Yes	No	No	Yes	Yes
Anti-chucking Horizontal	60% Less	60% Less	No	No	60% Less	60% Less
Shock Control Vertical	44% Less	44% Less	No	No	44% Less	44% Less
Short Bed Truck Capable	With Extended Pin Box and Sliding Hitch	With Extended Pin Box and Sliding Hitch	Yes	Yes	Yes	Yes
Extra Space in Truck Bed	No	No	Yes	Yes	Yes	Yes
Reduces Need for Wide Turns	No	No	Yes	Yes	Yes	Yes
Easier to Back Up	No	No	Yes	Yes	Yes	Yes
Convertible to Air-ride	Included	Included	Yes	Yes	Included	Included

*Not all tow vehicle and trailer combinations will allow 90-degree turn.

**Measurement is from the front bolts to the king pin.

PIN BOX MATRIX CONVERSION						
OEM Part Numbers	5th Airborne™ 16K <small>COMPLETE PART NUMBER</small>	5th Airborne™ 21K <small>COMPLETE PART NUMBER</small>	Sidewinder™ 16K <small>COMPLETE PART NUMBER</small>	Sidewinder™ 19K <small>COMPLETE PART NUMBER</small>	Elite Airborne / Sidewinder™ 16K <small>COMPLETE PART NUMBER</small>	Airborne / Sidewinder™ 19.5K <small>COMPLETE PART NUMBER</small>
STANDARD						
Fabex 520, 530, and 560 Lippert 1116 and 0115 RBW 7019	Not Available	5AB-S500-700	61410	61411	61412	61413
Fabex 663 M&M 663 Lippert 0719	Not Available	5AB-S0719-600	61420	61421	61422	61423
Venture CJ13515	Not Available	5AB-S13515	61450	Not Available	61452	Not Available
Dexter 221-0033-00	Not Available	Not Available	61450	Not Available	61452	Not Available
Leland 7910	Not Available	5AB-E7920	ST400-SW16K	ST400-SW19K	ST400-5AS16K	ST400-5AS02
Youngs Welding	Not Available	5AB-S800	ST500-SW16K	ST500-SW19K	ST500 & 5AS16K**	Not Available
EXTENDED						
Fabex 500, 503 and 765 Lippert 1716 RBW 7028	Not Available	5AB-E510-710	61410	61411	61412	61413
Fabex 665 M&M 665 Lippert 1621 HD	Not Available	5AB-E1621-610	61420	61421	61422	61423
Lippert 1621	5AB-E1621-16K*	5AB-E1621-610	61420	61421	61422	61423
Venture CJ13517	Not Available	5AB-E13517	61450	Not Available	61452	Not Available
Dexter 221-0031-00	Not Available	Not Available	61450	Not Available	61452	Not Available
Leland 7920 and 7921	Not Available	5AB-E7920	ST400-SW16K	ST400-SW19K	ST400-5AS16K	ST400-5AS02
Youngs Welding	Not Available	5AB-E810	ST500-SW16K	ST500-SW19K	ST500 & 5AS16K**	Not Available
TUBE						
Fabex 300, 314 and 316 Lippert 0516 RBW 7027 Atwood 2326	Not Available	5AB-T320	Not Available	Not Available	Not Available	Not Available
Atwood AB-34 and AB-72	Not Available	5AB-T7234	Not Available	Not Available	Not Available	Not Available
RBW 7016-2P	Not Available	5AB-T7016	Not Available	Not Available	Not Available	Not Available
Youngs Welding Straight 8x8	Not Available	5AB-T820	Not Available	Not Available	Not Available	Not Available

*Note: 5AB-E1621-16K is not rated to directly replace the Lippert 1621 HD models, only the Lippert 1621

**Note: Must order both part numbers separately

**ELITE AIRBORNE/SIDEWINDER™ COMBO
THE BEST OF BOTH WORLDS**

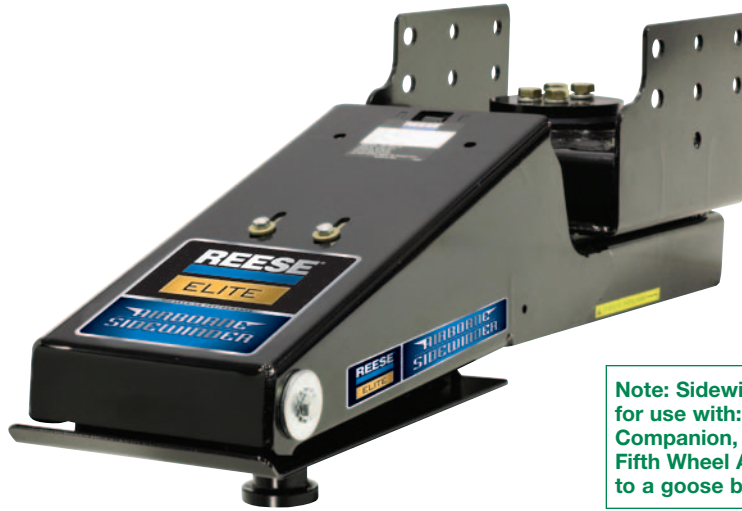

Note: Sidewinder™ is not designed for use with: Pull Rite, Curt Q5, B&W Companion, Cequent Hi-Rise™ or Fifth Wheel Adapters that connect to a goose ball.

Reese® Elite™ pin boxes provide the smoothest ride of the best air-ride pin box on the market and automatically eliminates turning and clearance headaches.

- Provides all the benefits of both the Reese 5th Airborne air-ride pin box and the Reese Sidewinder pin box
- Enhances maneuverability and comfort
- Takes the worry and discomfort out of traveling with a fifth wheel trailer
- Durable, lasting design combines attractive look with optimal function
- 90-plus degree** turning with a short bed truck
- SAE/CSA rated 16K
- Limited Lifetime Warranty

***Warning: Not all vehicles and trailer combinations will allow a 90-plus degree turn.*

Part No.	Description
5AS16K	Elite Airborne/Sidewinder™ Complete: 16K Arm Assembly w/King Pin
61412	Elite Airborne/Sidewinder™ Combo: 16K Arm Assembly w/King Pin #5AS16K, Turret w/ Hardware #61300 & Spacer Kit #61301
61422	Elite Airborne/Sidewinder™ Combo: 16K Arm Assembly w/King Pin #5AS16K, Turret w/ Hardware #61300
61452	Elite Airborne/Sidewinder™ Combo: 16K Arm Assembly w/King Pin #5AS16K, Turret w/ Hardware #61302
ST400-5AS16K	Elite Airborne/Sidewinder™ Combo: 16K Arm Assembly w/King Pin #5AS16K, Turret w/ Hardware #ST400

For pin box conversion see pin box matrix chart.



**AIRBORNE/SIDEWINDER™ COMBO
THE BEST OF BOTH WORLDS**



Note: Sidewinder™ is not designed for use with: Pull Rite, Curt Q5, B&W Companion, Cequent Hi-Rise™ or Fifth Wheel Adapters that connect to a goose ball.

Introducing the Reese® Airborne/Sidewinder. The 5th Airborne combined with the Sidewinder is the ultimate premium pin box and is covered by a limited lifetime warranty. It provides all the benefits of both. The 5th Airborne provides the smoothest ride of all the air-ride pin boxes on the market and easy automatic turning is offered by Sidewinder's nimble and quick design. No other hitch on the road takes the worry and discomfort out of your trailering experience. So sit back, relax and enjoy the smoothest ride on the road.

The Sidewinder system is designed for maximum flexibility and easy installation, using existing holes and hardware.

If your fifth wheel isn't already installed with a pin box from Reese, talk to your dealer about which one is right for you. The only thing smoother and more worry-free than getting one installed is riding with one.

Part No.	Description
5AS02	Airborne/Sidewinder™ Complete: 19.5K Arm Assembly w/King Pin
61413	Airborne/Sidewinder™ Combo: 19.5K Arm Assembly w/King Pin #5AS02, Turret w/ Hardware #61300 & Spacer Kit #61301
61423	Airborne/Sidewinder™ Combo: 19.5K Arm Assembly w/King Pin #5AS02, Turret w/ Hardware #61300
ST400-5AS02	Airborne/Sidewinder™ Combo: 19.5K Arm Assembly w/King Pin #5AS02, Turret w/ Hardware #ST400

For pin box conversion see pin box matrix chart.



19K SIDEWINDER™ NIMBLE AND QUICK, WORRY-FREE TURNING

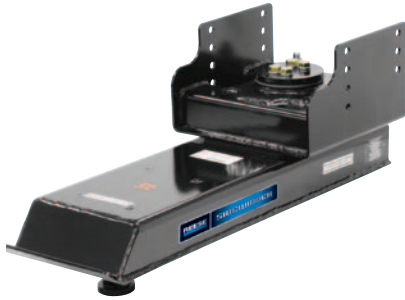

Reese® Sidewinder™, with a limited lifetime warranty, is the premium pin box designed specifically for short bed pickups. The nimble and quick design automatically eliminates turning and clearance headaches. Now you can make up to 90-degree plus* turns without exiting the truck. Without throwing a switch. Without pushing a button.

Sidewinder's king pin locking mechanism moves the pivot position 22" rear of the pin box's attachment point. This enables Sidewinder to handle up to a 90-degree plus turn effortlessly. By moving the pivot rearward while keeping the load centered over the axles, the trailer tracks more closely to the truck. This reduces the need for extra-wide turns and allows short bed pickups to jackknife with no fear of contact. And it's all done automatically. Sidewinder also offers faster steering wheel response, making backing up easier than ever before. The pivoting pin box makes hook up possible at any angle. And since the towing position of the pin box arm is locked in line with the truck, you can make full use of the truck bed space, giving you extra storage space for fuel tanks, toolboxes and cargo.

Don't let the slim looks fool you. Sidewinder has been built for strength. The C-channel design gives it more stability and strength than the standard pin box design. It also allows better load capacity and the ability to support heavier loads. Tested for real world conditions, Sidewinder has cleared rigorous testing by BOSCH automotive proving grounds and exceeds all SAE/CSA Standard 19K ratings requirements for RVs.

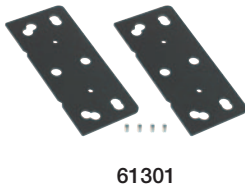

Part No.	Description
SW19K	Sidewinder™ Standard 19K Arm w/King Pin
61300	Sidewinder™ 12" Wide Turret w/Hardware Replaces Fabex, M & M or Lippert Pin Boxes
61301	Sidewinder™ Spacer Kit (for 12.5" Pin Boxes - use with #61300)
61411	Sidewinder™ Combo: 19K Arm w/King Pin #SW19K, Turret w/Hardware #61300 & Spacer Kit #61301
61421	Sidewinder™ Combo: 19K Arm w/King Pin #SW19K, Turret w/Hardware #61300
ST400	Sidewinder™ Turret w/Hardware
ST400-SW19K	Sidewinder™ Combo: 19K Arm w/King Pin #SW19K, Turret w/Hardware #ST400
ST500	Sidewinder™ Turret w/Hardware
ST500-SW19K	Sidewinder™ Combo: 19K Arm w/King Pin #SW19K, Turret w/Hardware #ST500

For pin box conversion see pin box matrix chart.

Note: Sidewinder™ is not designed for use with: Pull Rite, Curt Q5, B&W Companion, Cequent Hi-Rise™ or Fifth Wheel Adapters that connect to a goose ball.

Nimble and quick. Up to 90-degree plus turning.*

The Sidewinder moves the pivot from the truck bed to the pin box mounting brackets under the nose of the trailer. In this way you gain 22 inches of increased clearance instead of the typical 9 inches. It is now possible to jackknife the short bed truck with no fear of contact. It is all done automatically.

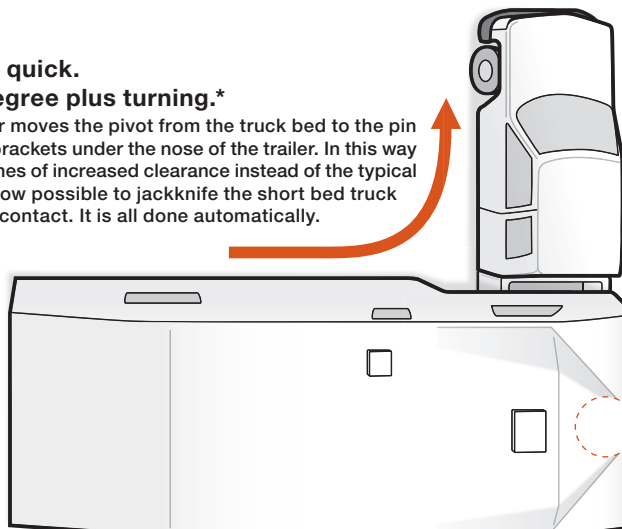

More space above bed walls for fuel tanks, toolboxes and cargo.

Universal king pin locking wedge is reversible and adjustable to work with all popular fifth-wheel hitch brands.

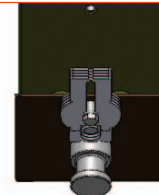

*WARNING: Not all tow vehicle and trailer combinations will allow a 90 degree turn

16K SIDEWINDER™
NIMBLE AND QUICK, WORRY-FREE TURNING

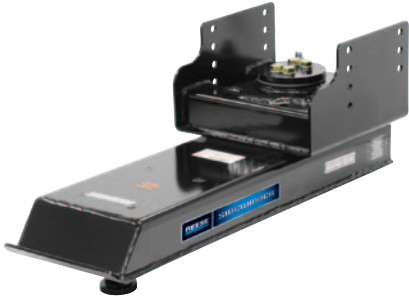

Reese® Sidewinder™, with a limited lifetime warranty, is the premium pin box designed specifically for short bed pickups. The nimble and quick design automatically eliminates turning and clearance headaches. Now you can make up to 90-degree plus* turns without exiting the truck. Without throwing a switch. Without pushing a button.

Sidewinder's king pin locking mechanism moves the pivot position 22" rear of the pin box's attachment point. This enables Sidewinder to handle up to a 90-degree plus turn effortlessly. By moving the pivot rearward while keeping the load centered over the axles, the trailer tracks more closely to the truck. This reduces the need for extra-wide turns and allows short bed pickups to jackknife with no fear of contact. And it's all done automatically. Sidewinder also offers faster steering wheel response, making backing up easier than ever before. The pivoting pin box makes hook up possible at any angle. And since the towing position of the pin box arm is locked in line with the truck, you can make full use of the truck bed space, giving you extra storage space for fuel tanks, toolboxes and cargo.

Don't let the slim looks fool you. Sidewinder has been built for strength. The C-channel design gives it more stability and strength than the standard pin box design. It also allows better load capacity and the ability to support heavier loads. Tested for real world conditions, Sidewinder has cleared rigorous testing by BOSCH automotive proving grounds and exceeds all SAE/CSA Standard 16K ratings requirements for RVs.

**WARNING: Not all tow vehicle and trailer combinations will allow a 90 degree turn*

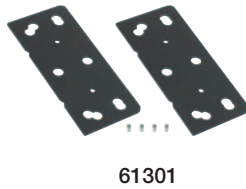

Part No.	Description
SW16K	Sidewinder™ Standard 16K Arm w/King Pin
61300	Sidewinder™ 12" Wide Turret w/Hardware Replaces Fabex, M & M or Lippert Pin Boxes
61301	Sidewinder™ Spacer Kit (for 12.5" Pin Boxes - use with #61300)
61410	Sidewinder™ Combo: 16K Arm w/King Pin #SW16K, Turret w/Hardware #61300 & Spacer Kit #61301
61420	Sidewinder™ Combo: 16K Arm w/King Pin #SW16K, Turret w/Hardware #61300
61302	Sidewinder™ 12" Wide Turret w/Hardware Replace Venture or Dexter Pin Boxes
61450	Sidewinder™ Combo: 16K Arm w/King Pin #SW16K, Turret w/Hardware #61302
ST400	Sidewinder™ Turret w/Hardware
ST400-SW16K	Sidewinder™ Combo: 16K Arm w/King Pin #SW16K, Turret w/Hardware #ST400
ST500	Sidewinder™ Turret w/Hardware
ST500-SW16K	Sidewinder™ Combo: 16K Arm w/King Pin #SW16K, Turret w/Hardware #ST500

For pin box conversion see pin box matrix chart.

Note: Sidewinder™ is not designed for use with: Pull Rite, Curt Q5, B&W Companion, Cequent Hi-Rise™ or Fifth Wheel Adapters that connect to a goose ball.

30850



SWW-03



CUSTOM WEDGES

- Designed to work with the Sidewinder and Airborne / Sidewinder
- Replacement wedge that is designed for specific fifth wheel hitches

Part No.	Description
SWW-01	Custom Wedge for Elite™ Series & Reese® 20K Fifth Wheels
30850	Custom Wedge for Pro Series™ Fifth Wheels
SWW-03	Custom Wedge for Reese® 16K Fifth Wheels
SWW-04	Custom Wedge for Husky Fifth Wheels
SWW-05	Custom Wedge for Hi-Jacker Fifth Wheels
SWW-06	Custom Wedge for B&W Fifth Wheels
SWW-07	Custom Wedge for RBW Fifth Wheels
SWW-08	Custom Wedge for Colibert Fifth Wheels
SWW-09	Custom Wedge for PullRite Fifth Wheels

5TH AIRBORNE™ MAKE YOUR NEXT GETAWAY A BREEZE



The smoothest ride:

Your fifth wheel takes a lot of abuse from turbulence caused by potholes, section dividers, bridge decks and heavily worn interstate highways. The 5th Airborne premium fifth wheel air-ride pin box acts as a buffer between the tow vehicle and the trailer, minimizing the challenges in the road. This significantly reduces the negative impact of vertical shock and longitudinal chucking. The 5th Airborne does more than improve your ride; it protects your investments by relieving stress on your coach's frame, cabinets, mechanicals, and support mechanisms. Furniture, appliances, TVs, computers, dishes, glassware and other fragile items stay in their places. Drivers and passengers also benefit from reduced fatigue and the improved safety provided by the 5th Airborne's smooth ride.

Best on the market:

The 5th Airborne premium fifth wheel air-ride pin box was engineered and developed by long-time veterans of the towing industry.

Tests prove it's the smoothest ride.
5th Airborne significantly outperforms two leading competitors.

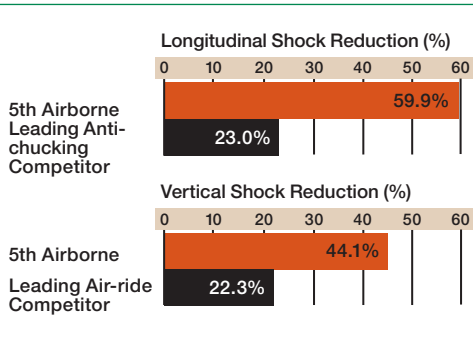

This product has been through grueling tests to measure its performance against the top two competing premium pin boxes on the market. The 5th Airborne pin box, with its innovative forward pivot design, outperformed both leading competitors. Test measurements were recorded in both the vertical (air-ride softening) direction and the longitudinal (anti-chucking) direction. The documented results proved that the 5th Airborne performed significantly better in both orientations.

The streamlined, high-tech design of 5th Airborne adds a touch of class to the otherwise mechanical-looking hitch. 5th Airborne is engineered with a 21K CSA rating/SAE and includes a limited lifetime warranty.

5th Airborne is designed to allow tuning of the air-spring, a feature that permits adjustment to optimize the performance of each rig combination. The air-spring is enclosed within the pin box, providing protection from UV exposure and road hazards. The entire pin box is preassembled and designed for easy installation using existing holes and hardware.

Part No.	Description
5AB-E13517	5th Airborne™ for Venture CJ13517 pin box
5AB-E1621-610	5th Airborne™ Extended 12" Wide Air Ride pin box
5AB-E510-710	5th Airborne™ Extended 12-1/2" Wide Air Ride pin box
5AB-E1621-16K	5th Airborne™ Extended 12" Wide Air Ride, 1-Piece Design - for Lippert 1621 only, 16K CSA rating/SAE
5AB-E7920	5th Airborne™ for Leland pin box
5AB-E810	5th Airborne™ for Youngs welding pin box
5AB-S0719-600	5th Airborne™ for Lippert 719 & Fabex 600 pin boxes
5AB-S13515	5th Airborne™ for Venture CJ13515 pin box
5AB-S500-700	5th Airborne™ Standard 12-1/2" Wide Air Ride pin box
5AB-S800	5th Airborne™ for Youngs welding pin box
5AB-T320	5th Airborne™ Tube Style 8" Wide Air Ride pin box
5AB-T7016	5th Airborne™ for RBW 7016
5AB-T7234	5th Airborne™ Tube Style 12-1/2" Wide
5AB-T820	5th Airborne™ Tube Style 8" Wide Air Ride pin box
5AB-E510-710K	5th Airborne™ Extended 12" Wide Air Ride pin box for 2007 Keystone Everest with Sidewinder

For pin box conversion see pin box matrix chart.

GOOSENECK HITCH SYSTEMS

Gooseneck Hitch Systems conveniently allow unrestricted use of the pickup bed. In-truck platforms support 2-5/16" and 3" hitch balls. All framework for Gooseneck Trailer Hitches reside under the bed of the truck with only the ball exposed above the bed of the truck. Stronger, and able to utilize the full suspension of the truck, Gooseneck Hitch Systems are rated up to full towing capacity of the vehicle as determined by the manufacturer. Bulldog Gooseneck Hitch Systems utilize a unique set of mounting rails, specific to each vehicle, that will accommodate any of the hitch heads.

HOW LARGE A TRAILER CAN I TOW?

Each truck has a published Gross Combined Weight Rating GCWR. This is the maximum allowable tow rating in terms of the combined vehicle and trailer weight. When the Gross Vehicle Weight GVW is subtracted, the maximum Gross Trailer Weight is revealed.

In this example, the maximum allowable trailer towing weight is 12,800 lbs. GTW. The rail kit for this vehicle has been tested to meet maximum vehicle tow capacity.

GCWR - GVW = MAX. GTW

2001 GMC Heavy Duty 2500, 4 Wheel Drive Extended Cab

Engine: Duramax 6600

Horsepower: 300 hp @ 3100 rpm

Torque: 520 lb. ft. @ 1800 rpm

Transmission: Allison 5-speed Automatic

Axle Ratio: 3.73 to 1

GVW: 9,200 lbs.

GCWR: 22,000 lbs.

22,000 lbs. GCWR - 9,200 lbs. GVW = 12,800 lbs. GTW

COMMON TERMINOLOGY:

Base Curb Weight - The nominal weight of a vehicle with standard equipment and a full tank of fuel. It does not include passengers, cargo or optional equipment.

Commercial Towing - Any vehicle/trailer combination exceeding 26,000 lbs. Gross Combined Weight GCW.

Commercial Vehicle - Any vehicle that exceeds 10,000 lbs. GVW.

Gross Vehicle Weight (GVW) - The actual weight of the vehicle when fully loaded. It is the base curb weight plus the cargo weight.

Gross Vehicle Weight Rating (GVWR) - The maximum allowable weight of the fully loaded vehicle.

Gross Combined Weight (GCW) - The actual weight of the vehicle and trailer combined. This weight should always be obtained by weighing the vehicle and trailer together on a scale.

Gross Combined Weight Rating (GCWR) - The maximum weight of the towing vehicle and the loaded trailer - including cargo and passengers.

Gross Axle Weight (GAW) - The total weight supported by each axle (front or rear). To compute this weight for your vehicle and trailer combined, take the loaded vehicle and trailer to a scale. With the trailer attached, place the front wheels of the vehicle on the scale to obtain the front GAW. To obtain the rear GAW, weigh the towing vehicle with the trailer attached, but with just the four wheels of the vehicle on the scale. The rear GAW is determined by subtracting the front GAW from that amount.

Gross Axle Weight Rating (GAWR) - The total weight each axle is capable of carrying. The total load on each axle must not exceed its GAWR.

Gross Trailer Weight (GTW) - The weight of a trailer fully loaded.

Maximum Loaded Trailer Weight - The maximum allowable fully loaded weight of the trailer. This weight is obtained by subtracting the towing vehicle's GVW from its GCWR.

Payload - The combined maximum allowable weight of cargo, occupants and optional equipment that the vehicle is designed to carry. (Gross Vehicle Weight Rating minus the base curb weight.)

Rail Kit - The components and hardware that mount the gooseneck hitch to the vehicle frame.

GOOSENECK HITCH SYSTEMS

GOOSENECK COUPLER FOR RV'S

Goose Box™ Gooseneck Coupler for RV's

ELITE™ UNDER-BED GOOSENECK HITCH SYSTEMS

Reese® Elite™ Under-Bed Gooseneck Hitch System

Reese® Elite™ Pop-In™ Ball Kit

ABOVE-BED GOOSENECK HITCHES

Reese® Above-Bed Gooseneck Hitch

Draw-Tite® Above-Bed Gooseneck Hitch

Pro Series™ Above-Bed Gooseneck Hitch

UNDER-BED GOOSENECK HITCH SYSTEMS

Draw-Tite® Under-Bed Gooseneck Hitch System

Draw-Tite® Hide-A-Goose™ Gooseneck Head

Draw-Tite® Fold-Down Gooseneck Platform

Draw-Tite® Remov-A-Ball® Gooseneck Platform

Draw-Tite® Hi-Rise™ Conversion Hitch

Draw-Tite® Above-Bed Gooseneck Hitch

Bulldog® Under-Bed Gooseneck Hitch System

Bulldog® Under-Bed Gooseneck Head

Bulldog® Fold-Down Gooseneck Platform

Bulldog® Remov-A-Ball® Gooseneck Platform

Bulldog® Hi-Rise™ Conversion Hitch

GOOSENECK HITCH SYSTEM ACCESSORIES

Gooseneck Hitch Accessories

GOOSENECK HITCH APPLICATIONS

Gooseneck Hitch Application Guide





STEP UP TO RV COMFORT AND KEEP YOUR GOOSENECK HITCH!

Take the heavy equipment out of the truck bed! The Goose Box™ gooseneck coupler is specifically designed for RV trailer owners who wish to tow with their gooseneck hitch. The Reese® Goose Box™ replaces a traditional pin box so the RV works with the truck gooseneck hitch. Includes 5th Airborne™ technology for a superb ride.

- World's first OE approved gooseneck adapter, Endorsed by Lippert Components, Inc. for their frame systems
- Fits Lippert #1621 and #1716 wing sets
- 5th Airborne™ expertise reduces stress transferred to the RV frame
- Independent lab tested & proven to provide a better ride than king pin "bolt-on" adapter solutions (Bosch Automotive Proving Grounds)
- Bulldog® gooseneck coupler technology with traditional king pin styling
- Air bag, dual shocks and rubber bumpers provide multi-directional shock absorption for a smoother driving experience
- Air pressure relief valve prevents overfilling of air bags
- Available in bulk or individual packaging
- Rated for 16,000 lb. capacity utilizing both CSA & SAE J2638 test standards
- Limited 7 year warranty



Air Pressure Relief Valve

Part No.	Description
94621	Goose Box™ For Lippert #1621 & #1716 Wing Sets (bulk - minimum order, 3 pcs.)
94622	Goose Box™ For Lippert #1621 & #1716 Wing Sets (carton)

Patent Pending.

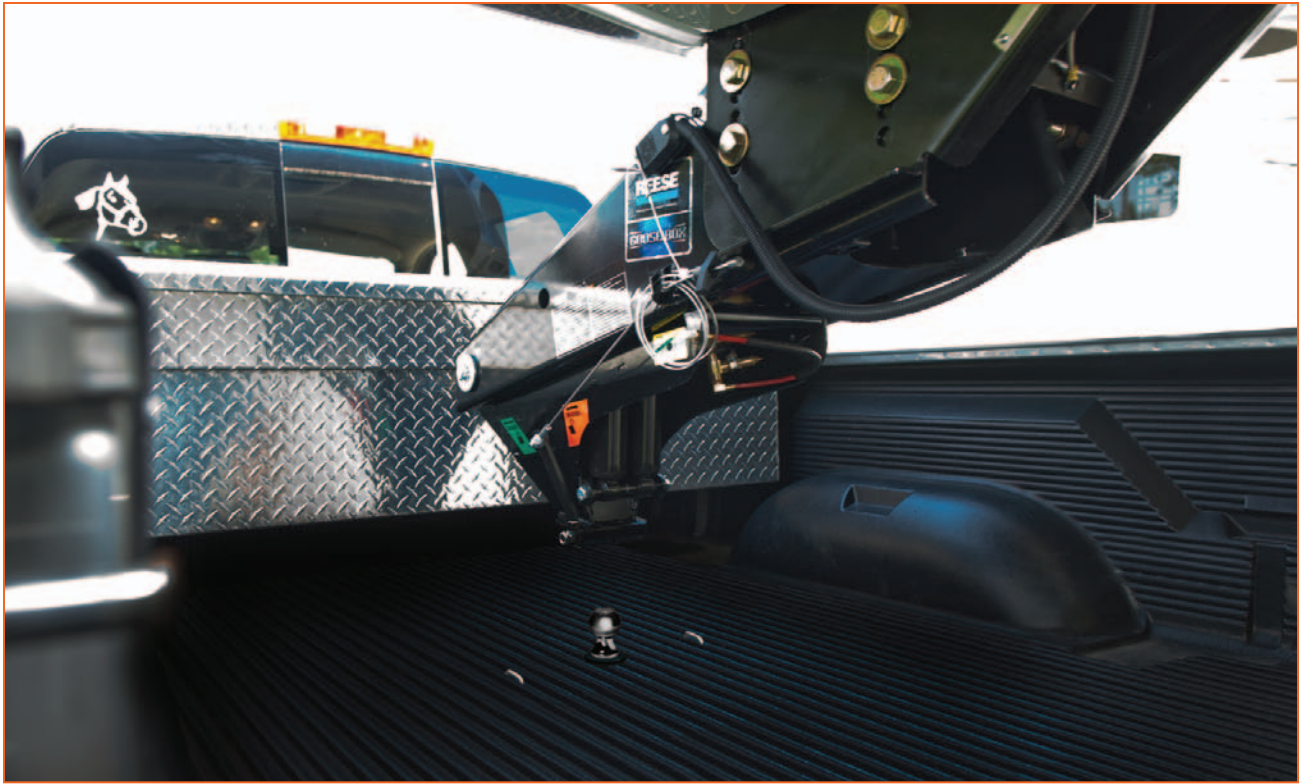

SAY YES, TO GOOSE BOX™!

Tests were conducted on a traditional pin box, existing gooseneck extension adapters, and the Goose Box™. The results were conclusive!



“The Goose Box is a great solution for fifth-wheel RV users who prefer to use gooseneck hitches,” said Jason Lippert, CEO of Lippert Components. “We are very pleased with the results of the thorough testing of the Goose Box, which demonstrates that it is compatible with our RV frame. As a result, the proper installation of a Goose Box pin box will be acceptable under our RV frame warranty.” – Lippert Press Release

After reviewing the Bosch Test reports for the Reese Goose Box™, Lippert Components (the world’s largest manufacturer of RV frames) accepts the Goose Box for the towing of RVs with gooseneck hitches. “Proper installation of a Goose Box in its intended application will not void the chassis warranty when installed on a coach either by the OEM or in the aftermarket.” – Jarod Lippert, Director of Marketing

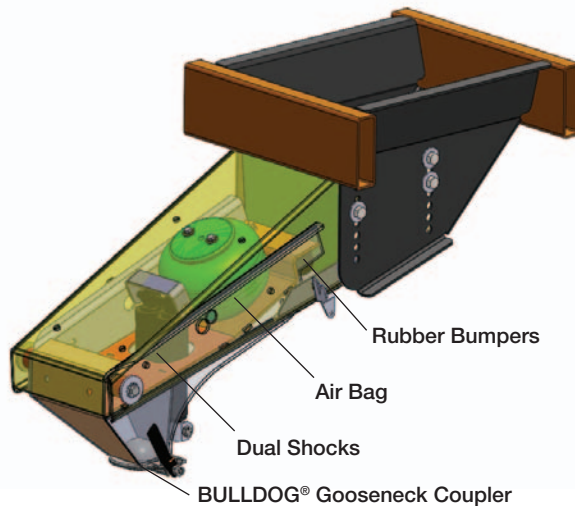



30138-26



30138

REESE® ELITE™ UNDER-BED GOOSENECK HITCH

- Easy Under-Bed bolt-in installation
- Rated for 25,000 lbs. gross weight capacity*
- Passes SAE J2638, the toughest industry standard
- Pop-In™ Ball
 - Lever inside ball head activates ball bearing locking system
 - Lift and turn lever to unlock and remove ball
- Two safety chain holders attach directly to rail system
- Fifth wheel ready uses outer four holes to mount a fifth wheel hitch
- Hole cover keeps Pop-In™ Ball sleeve free of debris
- Storage bag included
- Patented and Patents Pending

Aligns to center hole in 2011 Ford F-250 / F-350 / F-450 truck beds

Part No.	Description
30138-26	Elite™ Gooseneck Complete Hitch (includes #30126 rail and Pop-in™ ball kit)
30138	Elite™ Gooseneck Head with Pop-In™ 2-5/16" Ball (use with #30126 rail kit)

**Your actual weight capacity is limited to the towing vehicle or gooseneck rail kit capacity*

2011 Chevy Silverado / GMC Sierra 2500 & 3500 HD pickups



30158

Part No.	Description
30158-68	Elite™ Gooseneck Complete Hitch (includes #30868 rail and Pop-in™ ball kit)
30158	Elite™ Gooseneck Head w/Pop-In™ 2-5/16" Ball (use w/#30852 or #30868 rail kit)

**Your actual weight capacity is limited to the towing vehicle or gooseneck rail kit capacity.*

2010/2011 Dodge Ram 2500 & 3500 HD pickups

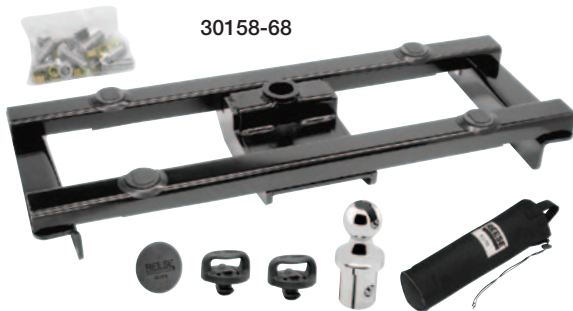

30158-68



30158-52



FIFTH WHEEL READY!



SEE APPLICATION GUIDE OR WWW.REESEPROD.COM FOR ADDITIONAL TRUCK APPLICATIONS.



30137

Lever inside ball head activates ball bearing locking system



30135



30134



30136



19311



19315

New



19314

ELITE™ POP-IN™ BALL KIT

- Pop-In™ Ball
 - Lever inside ball head activates ball bearing locking system
 - Lift and turn lever to unlock and remove ball
- Two safety chain holders
- Hole cover keeps Pop-In™ Ball sleeve free of debris
- Storage bag included
- Ball rated for 30,000 lbs. capacity*
- Fits 2011 Ford F-250 / F-350 / F-450 with factory installed OE rail system or aftermarket rails (#30126 & #30868)
- Patents Pending

Part No.	Description
30137	Elite™ Pop-In™ Ball Kit (Includes: (1) 2-5/16" Pop-In™ Ball #19311, (1) Storage Bag, (2) Safety Chain Attachments & (1) Hole Cover)
30136	Replacement Part, Hole Cover for Elite™ Under-Bed Gooseneck Hitch
30134	Replacement Part, Safety Chain Attachment for Elite™ Under-Bed Gooseneck Hitch
30135	Replacement Part, Storage Bag for Elite™ Under-Bed Bolt-On Gooseneck 2-5/16" Pop-In Ball #19311
19311	Replacement Part, 2-5/16" Pop-In™ Ball for Elite™ Under-Bed Gooseneck Hitch
19315	1" High Rise, 2-5/16" Pop-In™ Ball for Elite™ Under-Bed Gooseneck Hitch
19314	3" Pop-In™ Ball for Elite™ Under-Bed Gooseneck Hitch

*Your actual weight capacity is limited to the towing vehicle or gooseneck rail kit capacity.

SIGNATURE SERIES® ABOVE-BED GOOSENECK

- Rated for 30,000 lbs. capacity
- 2-5/16" forged, heat treated ball
- Specifically designed for the Professional tower who employs both fifth wheel and gooseneck trailers
- Utilizes the same vehicle specific under-bed rail kit system as the Elite™ fifth wheel
- Above-Bed Gooseneck can be easily removed for unobstructed use of the truck bed
- Weather resistant plastic covering provides protection from the elements and aesthetic appeal
- Built-in chain bracket to accommodate safety chain



30845

For use with Elite™ rail kits only



58419

Part No.	Description
30845	Signature Series® 30K Gooseneck
58419	Service kit adapter for Signature Series Fifth Wheels & Goosenecks when used on Elite™ Rail Kits (#30126 & #30868) & Ford OEM rail kits

Note: Will not fit trucks with beds shorter than 6' in length. Will not fit trucks with flareside/stepside.

25K ABOVE-BED GOOSENECK

- Easy installation and removal allows for full access to truck bed
- Utilizes same base rails as our fifth wheel hitches
- 2-5/16" heat treated ball
- In-truck platform rated for 25,000 lbs. gross vehicle towing weight and 6,250 lbs. vertical load
- Black powder coat finish



58079

Part No.	Description	Capacity	Pin Capacity
58079	25K Gooseneck Hitch	25,000 lbs.	6,250 lbs.
58208	Chevrolet Composite Bed Kit for gooseneck		

Rails and installation kit must be ordered separately (#30035, 10-bolt or #30095, 4-bolt).



GOOSENECK SYSTEM

Draw-Tite has designed a Gooseneck Hitch System to meet your gooseneck towing needs. The secret of the system is in the rail kit. We've designed rail kits to fit your specific truck that can attach to your choice of the Hide-A-Goose, Fold-Down or Remov-A-Ball® heads. Easy install, reliable service.

SEE APPLICATION GUIDE OR WWW.DRAW-TITE.COM FOR VEHICLE APPLICATIONS.

SAME RAIL KIT - 3 METHODS OF ATTACHMENT

Use fit guide below and select your vehicle.

Option #1 Hide-A-Goose – ball stores in truck bed.

Option #2 Fold-Down – ball folds down in truck bed.

Option #3 Remov-A-Ball® – ball removes and is stored separately.



Hide-A-Goose



Fold-Down



Remov-A-Ball



9460



9465



9464

30K HIDE-A-GOOSE™ GOOSENECK

- Allows full use of pick-up bed area when hauling cargo
- No alteration of OE exhaust systems required
- Accommodates all standard vehicle suspensions
- 2-5/16" forged, heat treated zinc ball standard, 3" ball optional
- Magnetic cover protects ball hole when not in use
- Rated for 30,000 lbs. gross trailer weight and 7,500 lbs. vertical load, tested to SAE J2638 Static and Reese® Dynamic Specs for 30,000 lbs. gross vehicle weight rating
- Rail kits are rated to match manufacturer's vehicle weight ratings
- Spring loaded safety chain loops included
- Requires installation rail kit

Part No.	Description
9460	Hide-A-Goose™ Wide Head
9465	Hide-A-Goose™ Narrow Head
9464	Hide-A-Goose™ Wide Head

Note: See fit guide in Application Catalog.



8339



25K FOLD-DOWN GOOSENECK

- Fold-Down design allows unrestricted use of the truck bed when not towing
- Takes only seconds to raise or lower the ball into position
- Forged, heat-treated 2-5/16" chrome ball standard
- Includes mounting hardware & integrated drop down spring loaded safety chain loops
- Oversize pull ring allows user to raise or lower the ball while wearing gloves
- Integrated grease fitting is visible & easily accessible
- Platform & ball rated for 25,000 lbs. gross vehicle towing weight and 6,250 lbs. vertical load
- Rail kits are rated to match manufacturer's vehicle weight ratings
- No alteration of factory exhaust systems required
- Requires installation rail kit

Part No.	Description
8339	Fold-Down Gooseneck Platform (2-5/16" ball included)



REMOV-A-BALL®



30K REMOV-A-BALL® GOOSENECK

- Allows full use of pick-up bed area when hauling cargo
- No alteration of OE exhaust systems required
- Accommodates all standard vehicle suspensions
- 2-5/16" forged, heat treated zinc ball standard, 3" ball optional
- Spring loaded chrome sliding pin insures positive ball lock
- Lockable to prevent ball theft (lock not included)
- Magnetic cover protects ball hole and activating lever slot when not in use
- In-truck platform may be used with rail kits or installed on any vehicle providing adequate structure to secure the platform
- In-truck platform is rated for 30,000 lbs. gross trailer weight and 7,500 lbs. vertical load and tested to V.E.S.C.-19 specs for 30,000 lbs. gross vehicle weight rating
- Rail kits are rated to match manufacturer's vehicle weight ratings
- Spring loaded safety chain loops included
- Requires installation rail kit

Part No.	Description
6300	Remov-A-Ball® Gooseneck Platform, includes 2-5/16" ball & cover

HI-RISE™ CONVERSION HITCH

Converts a gooseneck hitch into a fifth wheel hitch.



9480

- 4-Way pivoting head with self latching jaw design
- 4 degree side-to-side pivot for better control
- Fifth wheel height adjustments (14-1/4" - 18")
- 2 Bolts for bed Height Adjustments
- Offset Legs enhance performance while braking
- Adjustable stabilizer strips fit bed corrugation pattern
- Lockable, extended length handle
- Not Rated for use with Reese Sidewinder™
- Only works with B&W gooseneck hitch and Cequent (94XX) series heads utilizing (44XX) Series Rails
- 18K gross trailer weight / 4.5K pin weight capacity
- 2 year limited warranty

Part No.	Description
9480	Hi-Rise™ Conversion Hitch

Your actual weight capacity is limited to the towing vehicle or gooseneck rail kit capacity

25K ABOVE-BED GOOSENECK



6002

- Easy installation and removal allows for full access to truck bed
- Utilizes same base rails (#30035 or #30095) as our fifth wheel hitches
- 2-5/16" heat treated ball
- In-truck platform rated for 25,000 lbs. gross vehicle towing weight and 6,250 lbs. vertical load
- Black powder coat finish

Part No.	Description	Capacity	Pin Capacity
6002	25K Gooseneck Hitch	25,000 lbs.	6,250 lbs.
58208	Chevrolet Composite Bed Kit for gooseneck		

Rails and installation kit must be ordered separately (#30035, 10-bolt or #30095, 4-bolt).



IMPROVED

GOOSENECK SYSTEM

Bulldog has designed a Gooseneck Hitch System to meet your gooseneck towing needs. The secret of the system is in the rail kit. We've designed rail kits to fit your specific truck that can attach to your choice of the Under-Bed, Fold-Down or Remov-A-Ball® heads.

SEE APPLICATION GUIDE OR WWW.BULLDOGPRODUCTS.NET FOR VEHICLE APPLICATIONS.

SAME RAIL KIT - 3 METHODS OF ATTACHMENT

Use fit guide below and select your vehicle.

Option #1 Under-Bed – ball stores in truck bed.

Option #2 Fold-Down – ball folds down in truck bed.

Option #3 Remov-A-Ball® – ball removes and is stored separately.



Hide-A-Goose



Fold-Down



Remov-A-Ball



9470



9475

New



9474

30K UNDER-BED GOOSENECK

- Allows full use of pick-up bed area when hauling cargo
- No alteration of OE exhaust systems required
- Accommodates all standard vehicle suspensions
- 2-5/16" forged, heat treated zinc ball standard, 3" ball optional
- Magnetic cover protects ball hole when not in use
- Rated for 30,000 lbs. gross trailer weight and 7,500 lbs. vertical load, tested to SAE J2638 Static and Reese® Dynamic Specs for 30,000 lbs. gross vehicle weight rating
- Rail kits are rated to match manufacturer's vehicle weight ratings
- Spring loaded safety chain loops included
- Requires installation rail kit

Part No.	Description
9470	Under-Bed Gooseneck Wide Head
9475	Under-Bed Gooseneck Narrow Head
9474	Under-Bed Gooseneck Wide Head

Note: See fit guide in Application Catalog.



8339



25K FOLD-DOWN GOOSENECK

- Fold-Down design allows unrestricted use of the truck bed when not towing
- Takes only seconds to raise or lower the ball into position
- Forged, heat-treated 2-5/16" chrome ball standard
- Includes mounting hardware & integrated drop down spring loaded safety chain loops
- Oversize pull ring allows user to raise or lower the ball while wearing gloves
- Integrated grease fitting is visible & easily accessible
- Platform & ball rated for 25,000 lbs. gross vehicle towing weight and 6,250 lbs. vertical load
- Rail kits are rated to match manufacturer's vehicle weight ratings
- No alteration of factory exhaust systems required
- Requires installation rail kit

Part No.	Description
8339	Fold-Down Gooseneck Platform (2-5/16" ball included)



REMOV-A-BALL®



630044



30K REMOV-A-BALL® GOOSENECK

- Allows full use of pick-up bed area when hauling cargo
- No alteration of OE exhaust systems required
- Accommodates all standard vehicle suspensions
- 2-5/16" forged, heat treated zinc ball standard, 3" ball optional
- Spring loaded chrome sliding pin insures positive ball lock
- Lockable to prevent ball theft (lock not included)
- Magnetic cover protects ball hole and activating lever slot when not in use
- In-truck platform may be used with rail kits or installed on any vehicle providing adequate structure to secure the platform
- In-truck platform is rated for 30,000 lbs. gross trailer weight and 7,500 lbs. vertical load and tested to V.E.S.C.-19 specs for 30,000 lbs. gross vehicle weight rating
- Rail kits are rated to match manufacturer's vehicle weight ratings
- Spring loaded safety chain loops included
- Requires installation rail kit

Part No.	Description
630044	Remov-A-Ball® Gooseneck Platform, includes 2-5/16" ball & cover



9481

HI-RISE™ CONVERSION HITCH

Converts a gooseneck hitch into a fifth wheel hitch.

- 4-Way pivoting head with self latching jaw design
- 4 degree side-to-side pivot for better control
- Fifth wheel height adjustments (14-1/4" - 18")
- 2 Bolts for bed Height Adjustments
- Offset Legs enhance performance while braking
- Adjustable stabilizer strips fit bed corrugation pattern
- Lockable, extended length handle
- Not Rated for use with Reese Sidewinder™
- Only works with B&W gooseneck hitch and Cequent (94XX) series heads utilizing (44XX) Series Rails
- 18K gross trailer weight / 4.5K pin weight capacity
- 2 year limited warranty

Part No.	Description
9481	Hi-Rise™ Conversion Hitch

Your actual weight capacity is limited to the towing vehicle or gooseneck rail kit capacity



49080

Available in skid quantities of 24 (Example: 49080-024)

PRO SERIES™ 25K ABOVE-BED GOOSENECK

- Easy installation and removal allows for full access to truck bed
- Utilizes same base rails (#30035 or #30095) as our fifth wheel hitches
- Raised safety chain locations all for easy trailer connection
- 2-5/16" heat treated ball
- In-truck platform rated for 25,000 lbs. gross vehicle towing weight and 6,250 lbs. vertical load
- Ball is offset 2" to accommodate 6 & 8 ft. truck beds
- 5 year limited warranty



Part No.	Description	Capacity	Pin Capacity
49080	25K Gooseneck Hitch	25,000 lbs.	6,250 lbs.
58208	Chevrolet Composite Bed Kit for gooseneck		

Rails and installation kit must be ordered separately (#30035, 10-bolt or #30095, 4-bolt).

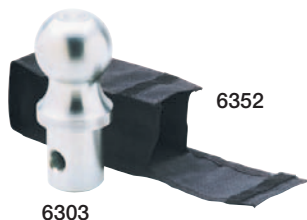

6352

6303

GOOSENECK HITCH ACCESSORIES & REPLACEMENT PARTS

Part No.	Description
5983	Replacement Magnetic Cover
6352	Nylon Pouch with velcro closure, stores balls when not in use
6303	Replacement 3" Ball for Remov-A-Ball®
5973	Replacement 2-5/16" Ball for Remov-A-Ball®
6308	Replacement U-Bolt Safety Chain Kit

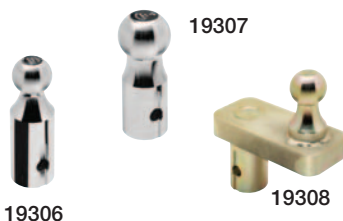

19307

19306

19308

UNDER-BED GOOSENECK ACCESSORIES

Part No.	Description
19306	2-5/16" Hitch Ball w/1" Rise for 946x / 947x gooseneck heads
19307	3" Hitch Ball for 946x / 947x gooseneck heads
19308	2-5/16" Hitch Ball w/5" Offset for 946x / 947x gooseneck heads
19309	2-5/16" Hitch Ball for 946x / 947x gooseneck heads

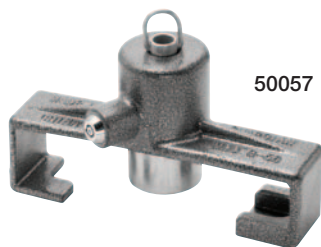

50057

GOOSENECK LOCK

Part No.	Description
50057	Gooseneck Lock

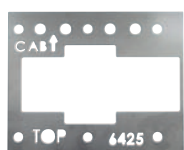

6425

GOOSENECK INSTALLATION TEMPLATES

- Stainless steel cutting template for Fold Down installation

Part No.	Description
6425	Fold Down Gooseneck Installation Template for #8339



58381

HOLE SAW

Part No.	Description
58381	3-1/2" Hole Saw

REESE® ELITE GOOSENECK

MAKE/MODEL		YEAR	FN	RAIL KIT	COMPLETE KIT	HEAD ONLY
CHEVROLET						
Pickup, Silverado	2500 HD 6.6 ft. Bed, 2 & 4 WD (New Body Style)	11-12	Ø	30868	30158-68	30158
	2500 HD 8 ft. Bed, 2 & 4 WD (New Body Style)	11-12	Ø	30868	30158-68	30158
	3500 HD 6.6 ft. Bed, 2 & 4 WD (New Body Style)	11-12	Ø	30868	30158-68	30158
	3500 HD 8 ft. Bed, 2 & 4 WD (New Body Style)	11-12	Ø	30868	30158-68	30158
DODGE						
Pickup, Ram, Full Size	2500 HD, Inc. Mega Cab, 2 & 4 WD	10-11	Ø	30852	30158-52	30158
	3500 HD, Inc. Mega Cab & Dually, 2 & 4 WD	10-11	Ø	30852	30158-52	30158
FORD						
F-250 Super Duty	Pickups Only - Will Not Fit Cab & Chassis	11-12	Ø	30126	30138-26	30138
F-350 Super Duty	Pickups Only - Will Not Fit Cab & Chassis	11-12	Ø	30126	30138-26	30138
F-450 Super Duty	Pickups Only - Will Not Fit Cab & Chassis	11-12	Ø	30126	30138-26	30138
GMC						
Pickup, Sierra	2500 HD 6.6 ft. Bed, 2 & 4 WD (New Body Style)	11-12	Ø	30868	30158-68	30158
	2500 HD 8 ft. Bed, 2 & 4 WD (New Body Style)	11-12	Ø	30868	30158-68	30158
	3500 HD 6.6 ft. Bed, 2 & 4 WD (New Body Style)	11-12	Ø	30868	30158-68	30158
	3500 HD 8 ft. Bed, 2 & 4 WD (New Body Style)	11-12	Ø	30868	30158-68	30158
	Denali HD 6.6 ft. Bed, 2 & 4 WD (New Body Style)	11-12	Ø	30868	30158-68	30158

DRAW-TITE® GOOSENECK APPLICATION GUIDE

Model/Style	Year	Rail Kit	FN	Hide-A-Goose		Remov-A-Ball	Fold-Down	
				Complete Kit	Head Only	Head Only	Head Only	
CHEVROLET								
Pickup, C/K Series	6 ft. Bed (Old Body Style)	88-00	4440	Ø,KE	9465-40	9465	6300	8339
	8 ft. Bed (Old Body Style)	88-00	4440	Ø,KE	9465-40	9465	6300	8339
Pickup, Silverado	1500 HD 6.6 ft. Bed, 2 & 4 WD	01-02	4454		9465-54	9465	6300	8339
		03-06	4454		9465-54	9465	6300	8339
	1500 HD 6.6 ft. Bed, 2 & 4 WD (Classic)	2007	4454		9465-54	9465	6300	8339
	1500 LD 6.6 ft. Bed, 2 & 4 WD	99-02	4454	Ø	9465-54	9465	6300	8339
		03-06	4454	Ø	9465-54	9465	6300	8339
	1500 LD 6.6 ft. Bed, 2 & 4 WD (Classic)	2007	4454	Ø	9465-54	9465	6300	8339
	1500 LD 6.6 ft. Bed, 2 & 4 WD (New Body Style)	07-10	4454	Ø	9465-54	9465	6300	8339
		11-12	4454	Ø	9465-54	9465	6300	8339
	1500 LD 8 ft. Bed, 2 & 4 WD	99-02	4454	Ø	9465-54	9465	6300	8339
		03-06	4454	Ø	9465-54	9465	6300	8339
	1500 LD 8 ft. Bed, 2 & 4 WD (Classic)	2007	4454	Ø	9465-54	9465	6300	8339
	1500 LD 8 ft. Bed, 2 & 4 WD (New Body Style)	07-10	4454	Ø	9465-54	9465	6300	8339
		11-12	4454	Ø	9465-54	9465	6300	8339
	2500 HD 6.6 ft. Bed, 2 & 4 WD	01-02	4434	Ø	9465-34	9465	6300	8339
		03-06	4434	Ø	9465-34	9465	6300	8339
	2500 HD 6.6 ft. Bed, 2 & 4 WD (Classic)	2007	4434	Ø	9465-34	9465	6300	8339
	2500 HD 6.6 ft. Bed, 2 & 4 WD (New Body Style)	07-10	4434	Ø	9465-34	9465	6300	8339
		11-12	4456	Ø,KH	9465-56	9465	6300	8339
	2500 HD 8 ft. Bed, 2 & 4 WD	01-02	4434	Ø	9465-34	9465	6300	8339
		03-06	4434	Ø	9465-34	9465	6300	8339
	2500 HD 8 ft. Bed, 2 & 4 WD (Classic)	2007	4434	Ø	9465-34	9465	6300	8339
	2500 HD 8 ft. Bed, 2 & 4 WD (New Body Style)	07-10	4434	Ø	9465-34	9465	6300	8339
		11-12	4456	Ø,KH	9465-56	9465	6300	8339
	2500 LD 6.6 ft. Bed, 2 & 4 WD	99-02	4454	Ø	9465-54	9465	6300	8339
		03-04	4454	Ø	9465-54	9465	6300	8339
	2500 LD 8 ft. Bed, 2 & 4 WD	99-02	4434	Ø	9465-34	9465	6300	8339
		03-04	4434	Ø	9465-34	9465	6300	8339
	3500 HD 6.6 ft. Bed, 2 & 4 WD (New Body Style)	07-10	4434	Ø	9465-34	9465	6300	8339
		11-12	4456	Ø,KH	9465-56	9465	6300	8339
	3500 HD 8 ft. Bed, 2 & 4 WD (New Body Style)	07-10	4434	Ø	9465-34	9465	6300	8339
		11-12	4456	Ø,KH	9465-56	9465	6300	8339
	3500 Series 8 ft. Bed, 2 & 4 WD	01-02	4445	Ø	9465-45	9465	6300	8339
		03-06	4445	Ø	9465-45	9465	6300	8339
	3500 Series 8 ft. Bed, 2 & 4 WD (Classic)	2007	4445	Ø	9465-45	9465	6300	8339
DODGE								
Pickup, Ram, Full Size		94-01	4439	Ø	9460-39	9460	6300	8339
	1500 Mega Cab w/6 ft. Bed, 2 & 4 WD	06-08	4435	Ø,JR	9464-35	9464	6300	8339
	1500 Only, Except Mega Cab	02-08	4438	Ø	9464-38	9464	6300	8339
	1500 Quad Cab w/6.4 ft. Bed, 2 & 4 WD	2009	4446	Ø	9464-46	9464	6300	8339
		10-12	4446	Ø	9464-46	9464	6300	8339
	1500 Regular Cab w/6.4 ft. Bed, 2 & 4 WD	2009	4446	Ø	9464-46	9464	6300	8339
		10-12	4446	Ø	9464-46	9464	6300	8339
	1500 Regular Cab w/8 ft. Bed, 2 & 4 WD	2009	4446	Ø	9464-46	9464	6300	8339
		10-12	4446	Ø	9464-46	9464	6300	8339
	2500 HD, Inc. Mega Cab, 2 & 4 WD	03-09	4435	Ø,JR	9464-35	9464	6300	8339
		10-12	4435	Ø,JR	9464-35	9464	6300	8339
	2500 Only, All Models	2002	4439	Ø	9460-39	9460	6300	8339
	3500 HD, Inc. Mega Cab & Dually, 2 & 4 WD	03-09	4435	Ø,JR	9464-35	9464	6300	8339
		10-12	4435	Ø,JR	9464-35	9464	6300	8339
	3500 Only, All Models	2002	4439	Ø	9460-39	9460	6300	8339

Note: Will not fit trucks with beds shorter than 6' feet in length or Flareside/Stepside. Rail Kits are rated to match manufacturer's vehicle tow weight ratings.

DRAW-TITE® GOOSENECK APPLICATION GUIDE

Model/Style	Year	Rail Kit	FN	Hide-A-Goose		Remov-A-Ball	Fold-Down	
				Complete Kit	Head Only	Head Only	Head Only	
FORD								
F-150	New Body Style, Regular Cab w/6.5 & 8 ft. Beds	04-08	4437	Ø	9465-37	9465	6300	8339
		09-12	4437	Ø	9465-37	9465	6300	8339
	New Body Style, SuperCab w/6.5 & 8 ft. Beds	04-08	4437	Ø	9465-37	9465	6300	8339
		09-12	4437	Ø	9465-37	9465	6300	8339
F-150 SuperCrew	New Body Style, w/6.5 ft. Bed	04-08	4437	Ø	9465-37	9465	6300	8339
		09-12	4437	Ø	9465-37	9465	6300	8339
F-250 Super Duty	Pickups Only - Will Not Fit Cab & Chassis	99-01	4448	Ø,JR	9460-48	9460	6300	8339
		02-04	4448	Ø,JR	9460-48	9460	6300	8339
		05-07	4448	Ø,JR	9460-48	9460	6300	8339
		08-10	4448	Ø,JR	9460-48	9460	6300	8339
		11-12	4448	Ø,JR	9460-48	9460	6300	8339
F-350 Super Duty	Pickups Only - Will Not Fit Cab & Chassis	99-01	4448	Ø,JR	9460-48	9460	6300	8339
		02-04	4448	Ø,JR	9460-48	9460	6300	8339
		05-07	4448	Ø,JR	9460-48	9460	6300	8339
		08-10	4448	Ø,JR	9460-48	9460	6300	8339
		11-12	4448	Ø,JR	9460-48	9460	6300	8339
F-450 Super Duty	Pickups Only - Will Not Fit Cab & Chassis	08-10	4449	Ø,JR	9460-49	9460	6300	8339
		11-12	4449	Ø,JR	9460-49	9460	6300	8339
GMC								
Pickup, C/K Series	6 ft. Bed (Old Body Style)	88-00	4440	Ø,KE	9465-40	9465	6300	8339
	8 ft. Bed (Old Body Style)	88-00	4440	Ø,KE	9465-40	9465	6300	8339
Pickup, Sierra	1500 HD 6.6 ft. Bed, 2 & 4 WD	01-02	4454		9465-54	9465	6300	8339
		03-06	4454		9465-54	9465	6300	8339
	1500 HD 6.6 ft. Bed, 2 & 4 WD (Classic)	2007	4454		9465-54	9465	6300	8339
	1500 LD 6.6 ft. Bed, 2 & 4 WD	99-02	4454	Ø	9465-54	9465	6300	8339
		03-06	4454	Ø	9465-54	9465	6300	8339
	1500 LD 6.6 ft. Bed, 2 & 4 WD (Classic)	2007	4454	Ø	9465-54	9465	6300	8339
	1500 LD 6.6 ft. Bed, 2 & 4 WD (New Body Style)	07-10	4454	Ø	9465-54	9465	6300	8339
		11-12	4454	Ø	9465-54	9465	6300	8339
	1500 LD 8 ft. Bed (Classic)	2007	4454	Ø	9465-54	9465	6300	8339
		1500 LD 8 ft. Bed, 2 & 4 WD	99-02	4454	Ø	9465-54	9465	6300
	03-06		4454	Ø	9465-54	9465	6300	8339
	1500 LD 8 ft. Bed, 2 & 4 WD (New Body Style)	07-10	4454	Ø	9465-54	9465	6300	8339
		11-12	4454	Ø	9465-54	9465	6300	8339
	2500 HD 6.6 ft. Bed, 2 & 4 WD	01-02	4434	Ø	9465-34	9465	6300	8339
		03-06	4434	Ø	9465-34	9465	6300	8339
	2500 HD 6.6 ft. Bed, 2 & 4 WD (Classic)	2007	4434	Ø	9465-34	9465	6300	8339
		2500 HD 6.6 ft. Bed, 2 & 4 WD (New Body Style)	07-10	4434	Ø	9465-34	9465	6300
11-12	4456		Ø,KH	9465-56	9465	6300	8339	
2500 HD 8 ft. Bed, 2 & 4 WD	01-02	4434	Ø	9465-34	9465	6300	8339	
	03-06	4434	Ø	9465-34	9465	6300	8339	
2500 HD 8 ft. Bed, 2 & 4 WD (Classic)	2007	4434	Ø	9465-34	9465	6300	8339	
	2500 HD 8 ft. Bed, 2 & 4 WD (New Body Style)	07-10	4434	Ø	9465-34	9465	6300	8339
11-12		4456	Ø,KH	9465-56	9465	6300	8339	
2500 LD 6.6 ft. Bed, 2 & 4 WD	99-02	4454	Ø	9465-54	9465	6300	8339	
	03-04	4454	Ø	9465-54	9465	6300	8339	
2500 LD 8 ft. Bed, 2 & 4 WD	99-02	4434	Ø	9465-34	9465	6300	8339	
	03-04	4434	Ø	9465-34	9465	6300	8339	
3500 HD 6.6 ft. Bed, 2 & 4 WD (New Body Style)	07-10	4434	Ø	9465-34	9465	6300	8339	
	11-12	4456	Ø,KH	9465-56	9465	6300	8339	
3500 HD 8 ft. Bed, 2 & 4 WD (New Body Style)	07-10	4434	Ø	9465-34	9465	6300	8339	
	11-12	4456	Ø,KH	9465-56	9465	6300	8339	

Note: Will not fit trucks with beds shorter than 6' feet in length or Flareside/Stepside. Rail Kits are rated to match manufacturer's vehicle tow weight ratings.

Model/Style	Year	Rail Kit	FN	Hide-A-Goose		Remov-A-Ball Head Only	Fold-Down Head Only	
				Complete Kit	Head Only			
GMC (Continued)								
Pickup, Sierra	3500 Series 8 ft. Bed, 2 & 4 WD	01-02	4445	Ø	9465-45	9465	6300	8339
		03-06	4445	Ø	9465-45	9465	6300	8339
	3500 Series 8 ft. Bed, 2 & 4 WD (Classic)	2007	4445	Ø	9465-45	9465	6300	8339
TOYOTA								
Tundra	Double Cab 6.5 ft. Bed	07-09	4436	Ø,JR	9465-36	9465	N/A	N/A
		10-12	4436	Ø,JR	9465-36	9465	N/A	N/A
	Double Cab 8 ft. Bed	07-09	4436	Ø,JR	9465-36	9465	N/A	N/A
		10-12	4436	Ø,JR	9465-36	9465	N/A	N/A
	Regular Cab 6.5 ft. Bed	07-09	4436	Ø,JR	9465-36	9465	N/A	N/A
		10-12	4436	Ø,JR	9465-36	9465	N/A	N/A
Regular Cab 8 ft. Bed	07-09	4436	Ø,JR	9465-36	9465	N/A	N/A	
		10-12	4436	Ø,JR	9465-36	9465	N/A	N/A

Note: Will not fit trucks with beds shorter than 6' feet in length or Flareside/Stepside. Rail Kits are rated to match manufacturer's vehicle tow weight ratings.

JR = Exhaust must be temporarily lowered for installation.

KE = Does not fit 88-91 4 Dr. Crew Cab models.

KH = Minor heat shield modification may be required.

Ø = Uses all existing holes, no drilling required.

Model/Style	Year	Rail Kit	FN	Under-Bed Gooseneck		Remov-A-Ball	Fold-Down	
				Complete Kit	Head Only	Head Only	Head Only	
CHEVROLET								
Pickup, C/K Series	6 ft. Bed (Old Body Style)	88-00	4440	Ø,KE	9475-40	9475	630044	8339
	8 ft. Bed (Old Body Style)	88-00	4440	Ø,KE	9475-40	9475	630044	8339
Pickup, Silverado	1500 HD 6.6 ft. Bed, 2 & 4 WD	01-02	4454		9475-54	9475	630044	8339
		03-06	4454		9475-54	9475	630044	8339
	1500 HD 6.6 ft. Bed, 2 & 4 WD (Classic)	2007	4454		9475-54	9475	630044	8339
	1500 LD 6.6 ft. Bed, 2 & 4 WD	99-02	4454	Ø	9475-54	9475	630044	8339
		03-06	4454	Ø	9475-54	9475	630044	8339
	1500 LD 6.6 ft. Bed, 2 & 4 WD (Classic)	2007	4454	Ø	9475-54	9475	630044	8339
	1500 LD 6.6 ft. Bed, 2 & 4 WD (New Body Style)	07-10	4454	Ø	9475-54	9475	630044	8339
		11-12	4454	Ø	9475-54	9475	630044	8339
	1500 LD 8 ft. Bed, 2 & 4 WD	99-02	4454	Ø	9475-54	9475	630044	8339
		03-06	4454	Ø	9475-54	9475	630044	8339
	1500 LD 8 ft. Bed, 2 & 4 WD (Classic)	2007	4454	Ø	9475-54	9475	630044	8339
	1500 LD 8 ft. Bed, 2 & 4 WD (New Body Style)	07-10	4454	Ø	9475-54	9475	630044	8339
		11-12	4454	Ø	9475-54	9475	630044	8339
	2500 HD 6.6 ft. Bed, 2 & 4 WD	01-02	4434	Ø	9475-34	9475	630044	8339
		03-06	4434	Ø	9475-34	9475	630044	8339
	2500 HD 6.6 ft. Bed, 2 & 4 WD (Classic)	2007	4434	Ø	9475-34	9475	630044	8339
	2500 HD 6.6 ft. Bed, 2 & 4 WD (New Body Style)	07-10	4434	Ø	9475-34	9475	630044	8339
		11-12	4456	Ø,KH	9475-56	9475	630044	8339
	2500 HD 8 ft. Bed, 2 & 4 WD	01-02	4434	Ø	9475-34	9475	630044	8339
		03-06	4434	Ø	9475-34	9475	630044	8339
	2500 HD 8 ft. Bed, 2 & 4 WD (Classic)	2007	4434	Ø	9475-34	9475	630044	8339
	2500 HD 8 ft. Bed, 2 & 4 WD (New Body Style)	07-10	4434	Ø	9475-34	9475	630044	8339
		11-12	4456	Ø,KH	9475-56	9475	630044	8339
	2500 LD 6.6 ft. Bed, 2 & 4 WD	99-02	4454	Ø	9475-54	9475	630044	8339
		03-04	4454	Ø	9475-54	9475	630044	8339
	2500 LD 8 ft. Bed, 2 & 4 WD	99-02	4434	Ø	9475-34	9475	630044	8339
		03-04	4434	Ø	9475-34	9475	630044	8339
	3500 HD 6.6 ft. Bed, 2 & 4 WD (New Body Style)	07-10	4434	Ø	9475-34	9475	630044	8339
		11-12	4456	Ø,KH	9475-56	9475	630044	8339
	3500 HD 8 ft. Bed, 2 & 4 WD (New Body Style)	07-10	4434	Ø	9475-34	9475	630044	8339
		11-12	4456	Ø,KH	9475-56	9475	630044	8339
	3500 Series 8 ft. Bed, 2 & 4 WD	01-02	4445	Ø	9475-45	9475	630044	8339
		03-06	4445	Ø	9475-45	9475	630044	8339
	3500 Series 8 ft. Bed, 2 & 4 WD (Classic)	2007	4445	Ø	9475-45	9475	630044	8339
DODGE								
Pickup, Ram, Full Size		94-01	4439	Ø	9470-39	9470	630044	8339
	1500 Mega Cab w/6 ft. Bed, 2 & 4 WD	06-08	4435	Ø,JR	9474-35	9474	630044	8339
	1500 Only, Except Mega Cab	02-08	4438	Ø	9474-38	9474	630044	8339
	1500 Quad Cab w/6.4 ft. Bed, 2 & 4 WD	2009	4446	Ø	9474-46	9474	630044	8339
		10-12	4446	Ø	9474-46	9474	630044	8339
	1500 Regular Cab w/6.4 ft. Bed, 2 & 4 WD	2009	4446	Ø	9474-46	9474	630044	8339
		10-12	4446	Ø	9474-46	9474	630044	8339
	1500 Regular Cab w/8 ft. Bed, 2 & 4 WD	2009	4446	Ø	9474-46	9474	630044	8339
		10-12	4446	Ø	9474-46	9474	630044	8339
	2500 HD, Inc. Mega Cab, 2 & 4 WD	03-09	4435	Ø,JR	9474-35	9474	630044	8339
		10-12	4435	Ø,JR	9474-35	9474	630044	8339
	2500 Only, All Models	2002	4439	Ø	9470-39	9470	630044	8339
	3500 HD, Inc. Mega Cab & Dually, 2 & 4 WD	03-09	4435	Ø,JR	9474-35	9474	630044	8339
		10-12	4435	Ø,JR	9474-35	9474	630044	8339
	3500 Only, All Models	2002	4439	Ø	9470-39	9470	630044	8339

Note: Will not fit trucks with beds shorter than 6' feet in length or Flareside/Stepside. Rail Kits are rated to match manufacturer's vehicle tow weight ratings.

Model/Style	Year	Rail Kit	FN	Under-Bed Gooseneck		Remov-A-Ball	Fold-Down	
				Complete Kit	Head Only	Head Only	Head Only	
FORD								
F-150	New Body Style, Regular Cab w/6.5 & 8 ft. Beds	04-08	4437	Ø	9475-37	9475	630044	8339
		09-12	4437	Ø	9475-37	9475	630044	8339
	New Body Style, SuperCab w/6.5 & 8 ft. Beds	04-08	4437	Ø	9475-37	9475	630044	8339
		09-12	4437	Ø	9475-37	9475	630044	8339
F-150 SuperCrew	New Body Style, w/6.5 ft. Bed	04-08	4437	Ø	9475-37	9475	630044	8339
		09-12	4437	Ø	9475-37	9475	630044	8339
F-250 Super Duty	Pickups Only - Will Not Fit Cab & Chassis	99-01	4448	Ø, JR	9470-48	9470	630044	8339
		02-04	4448	Ø, JR	9470-48	9470	630044	8339
		05-07	4448	Ø, JR	9470-48	9470	630044	8339
		08-10	4448	Ø, JR	9470-48	9470	630044	8339
		11-12	4448	Ø, JR	9470-48	9470	630044	8339
		99-01	4448	Ø, JR	9470-48	9470	630044	8339
		02-04	4448	Ø, JR	9470-48	9470	630044	8339
F-350 Super Duty	Pickups Only - Will Not Fit Cab & Chassis	05-07	4448	Ø, JR	9470-48	9470	630044	8339
		08-10	4448	Ø, JR	9470-48	9470	630044	8339
		11-12	4448	Ø, JR	9470-48	9470	630044	8339
F-450 Super Duty	Pickups Only - Will Not Fit Cab & Chassis	08-10	4449	Ø, JR	9470-49	9470	630044	8339
		11-12	4449	Ø, JR	9470-49	9470	630044	8339
GMC								
Pickup, C/K Series	6 ft. Bed (Old Body Style)	88-00	4440	Ø, KE	9475-40	9475	630044	8339
	8 ft. Bed (Old Body Style)	88-00	4440	Ø, KE	9475-40	9475	630044	8339
Pickup, Sierra	1500 HD 6.6 ft. Bed, 2 & 4 WD	01-02	4454		9475-54	9475	630044	8339
		03-06	4454		9475-54	9475	630044	8339
	1500 HD 6.6 ft. Bed, 2 & 4 WD (Classic)	2007	4454		9475-54	9475	630044	8339
	1500 LD 6.6 ft. Bed, 2 & 4 WD	99-02	4454	Ø	9475-54	9475	630044	8339
		03-06	4454	Ø	9475-54	9475	630044	8339
	1500 LD 6.6 ft. Bed, 2 & 4 WD (Classic)	2007	4454	Ø	9475-54	9475	630044	8339
	1500 LD 6.6 ft. Bed, 2 & 4 WD (New Body Style)	07-10	4454	Ø	9475-54	9475	630044	8339
		11-12	4454	Ø	9475-54	9475	630044	8339
	1500 LD 8 ft. Bed (Classic)	2007	4454	Ø	9475-54	9475	630044	8339
		99-02	4454	Ø	9475-54	9475	630044	8339
	1500 LD 8 ft. Bed, 2 & 4 WD	03-06	4454	Ø	9475-54	9475	630044	8339
		07-10	4454	Ø	9475-54	9475	630044	8339
	1500 LD 8 ft. Bed, 2 & 4 WD (New Body Style)	11-12	4454	Ø	9475-54	9475	630044	8339
		01-02	4434	Ø	9475-34	9475	630044	8339
	2500 HD 6.6 ft. Bed, 2 & 4 WD	03-06	4434	Ø	9475-34	9475	630044	8339
		2007	4434	Ø	9475-34	9475	630044	8339
	2500 HD 6.6 ft. Bed, 2 & 4 WD (Classic)	07-10	4434	Ø	9475-34	9475	630044	8339
		11-12	4456	Ø, KH	9475-56	9475	630044	8339
	2500 HD 6.6 ft. Bed, 2 & 4 WD (New Body Style)	01-02	4434	Ø	9475-34	9475	630044	8339
		03-06	4434	Ø	9475-34	9475	630044	8339
	2500 HD 8 ft. Bed, 2 & 4 WD	2007	4434	Ø	9475-34	9475	630044	8339
		07-10	4434	Ø	9475-34	9475	630044	8339
	2500 HD 8 ft. Bed, 2 & 4 WD (Classic)	11-12	4456	Ø, KH	9475-56	9475	630044	8339
		07-10	4434	Ø	9475-34	9475	630044	8339
	2500 HD 8 ft. Bed, 2 & 4 WD (New Body Style)	11-12	4456	Ø, KH	9475-56	9475	630044	8339
		99-02	4454	Ø	9475-54	9475	630044	8339
	2500 LD 6.6 ft. Bed, 2 & 4 WD	03-04	4454	Ø	9475-54	9475	630044	8339
		99-02	4434	Ø	9475-34	9475	630044	8339
	2500 LD 8 ft. Bed, 2 & 4 WD	03-04	4434	Ø	9475-34	9475	630044	8339
		07-10	4434	Ø	9475-34	9475	630044	8339
	3500 HD 6.6 ft. Bed, 2 & 4 WD (New Body Style)	11-12	4456	Ø, KH	9475-56	9475	630044	8339
		07-10	4434	Ø	9475-34	9475	630044	8339
	3500 HD 8 ft. Bed, 2 & 4 WD (New Body Style)	11-12	4456	Ø, KH	9475-56	9475	630044	8339
		07-10	4434	Ø	9475-34	9475	630044	8339

Note: Will not fit trucks with beds shorter than 6' feet in length or Flareside/Stepside. Rail Kits are rated to match manufacturer's vehicle tow weight ratings.

Model/Style	Year	Rail Kit	FN	Under-Bed Gooseneck		Remov-A-Ball	Fold-Down	
				Complete Kit	Head Only	Head Only	Head Only	
GMC (Continued)								
Pickup, Sierra	3500 Series 8 ft. Bed, 2 & 4 WD	01-02	4445	Ø	9475-45	9475	630044	8339
		03-06	4445	Ø	9475-45	9475	630044	8339
	3500 Series 8 ft. Bed, 2 & 4 WD (Classic)	2007	4445	Ø	9475-45	9475	630044	8339
TOYOTA								
Tundra	Double Cab 6.5 ft. Bed	07-09	4436	Ø,JR	9475-36	9475	N/A	N/A
		10-12	4436	Ø,JR	9475-36	9475	N/A	N/A
	Double Cab 8 ft. Bed	07-09	4436	Ø,JR	9475-36	9475	N/A	N/A
		10-12	4436	Ø,JR	9475-36	9475	N/A	N/A
	Regular Cab 6.5 ft. Bed	07-09	4436	Ø,JR	9475-36	9475	N/A	N/A
		10-12	4436	Ø,JR	9475-36	9475	N/A	N/A
Regular Cab 8 ft. Bed	07-09	4436	Ø,JR	9475-36	9475	N/A	N/A	
		10-12	4436	Ø,JR	9475-36	9475	N/A	N/A

Note: Will not fit trucks with beds shorter than 6' feet in length or Flareside/Stepside. Rail Kits are rated to match manufacturer's vehicle tow weight ratings.

JR = Exhaust must be temporarily lowered for installation.

KE = Does not fit 88-91 4 Dr. Crew Cab models.

KH = Minor heat shield modification may be required.

Ø = Uses all existing holes, no drilling required.

trailer BRAKE CONTROLS

**SMART
BRAKING**

Smart Braking With Proportional Technology

Unlike timed brake controls that deliver the same power under all braking conditions, Tekonsha Brake Controls use Proportional Technology that senses the type of braking event, and applies appropriate power to the trailer brakes.



PRODIGY® RF

PRODIGY® P2

P3®

PRIMUS™ IQ

VOYAGER®

INNOVATIVE TRAILER BRAKING SOLUTIONS

Tekonsha® is the industry leader and innovator in electric trailer brake controls and breakaway systems. No matter what you are towing, Tekonsha can help you stop it.

Eliminate Hardwiring

All Tekonsha brake controls include adapter for OE Wire Harnesses. Simply "Plug & Play!"



BRAKE CONTROLS

ELECTRIC TRAILER BRAKE CONTROLS

Tekonsha® Prodigy® RF

Tekonsha® P3® / Prodigy® P2

Tekonsha® Primus™ IQ / Voyager®

Reese® Brakeman® Ultra / Brakeman® Digital /
Brakeman® Compact

Draw-Tite® I-Stop™ IQ

Draw-Tite® Activator® III / Activator® II / Activator®

Pro Series™ Pilot® / POD®

Brake Control Accessories

Pulse Preventer

Brake Mate™ Wiring Kits



BRAKE CONTROL WIRING HARNESES

Brake Control Wiring Harnesses

Vehicle Specific Brake Control Wiring
Harness Applications





PRODIGY® RF
THE PERFECT SHARED-TRAILER SOLUTION

If you take to the road with multiple vehicles, there's really only one solution: PRODIGY® RF. Consider all it offers:

- User does not need a dash mounted, hard wired brake control
- True proportional trailer braking, forward or reverse
- No level adjustment necessary
- Trailer braking power supplied via 7-Way Connector from the vehicle
- Suitable for use on any trailer with up to 3 braking axles

In the Tow Vehicle (Hand Held unit):

- Wireless communication between the remote hand unit and trailer mounted power module eliminates the need for under dash wiring
- Easy to see LED display for trailer brake voltage, power output and diagnostics

- Easy to use remote hand control; includes the Prodigy "Boost" system to allow for different levels of customized braking
- Unit provides continual diagnostic scanning with a visual warning display
- Hand held unit plugs into any standard 12 volt power accessory adaptor
- Hand held unit has a 5-year limited warranty

On the Trailer (Power Module Unit):

- Power module uses standard RV Blade style (Bargman) 7-Way truck and trailer connectors
- Trailer Power Module is watertight and is powered through 7-way cable from the tow vehicle.
- Multiple mounting options on the tongue or front of the trailer
- Trailer mounted power module has a 15-year limited warranty (1-year limited warranty on cord)

Part No.	Description	Packaging
90250	Prodigy® RF Trailer Mount Brake Control w/Hand Held Unit	Display Box - Tekonsha
90251	Prodigy® RF Remote Hand Held Unit, Replacement Part	Clam Shell - Tekonsha



90195



NOTE: Plug & Play feature allows quick and easy connection. It adapts to all Cequent 2-Plug vehicle specific brake control wiring harnesses.



P3®

TAKING INNOVATION TO A WHOLE NEW LEVEL

After receiving valuable insight from industry experts and our own customers, Tekonsha® did something truly amazing: We listened and responded. The result is the P3; the industry's most advanced electric trailer brake control. A true proportional braking system, P3 has several added features, making it the new standard for electric trailer brake controls.

- A distinct, easy-to-read LCD display with multiple screen color options
- “Up-Front” controls provide easy access to all P3 features
- Easy to understand diagnostics show output current, battery/brake/output voltage
- A “flashing red” warning system alerts user to “No Trailer Brake” situations
- Select Electric over Hydraulic or Electric trailer brake mode
- Screen information display in English, French or Spanish
- “The Original Boost” feature allows for different levels of customized braking
- Compact, dash-hugging design
- Integrated Plug & Play port for 2-plug adapters
- Snap-in mounting clip allows user to remove and store the control when not in use
- Electric trailer brake control for up to 4 braking axles
- Limited lifetime warranty (some conditions apply)

Part No.	Description	Packaging
90195	P3® Proportional Electronic Trailer Brake Control	Display Box - Tekonsha

PRODIGY® P2

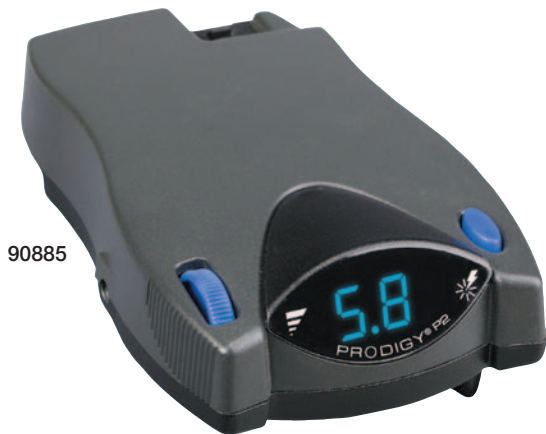

90885

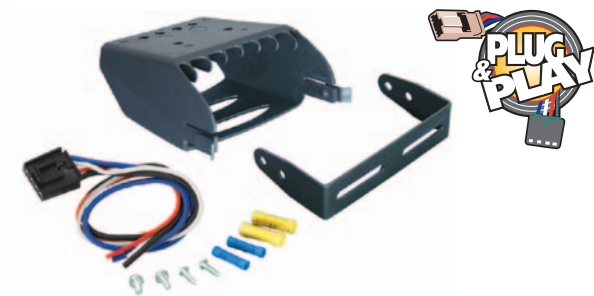

PRODIGY® P2

ADVANCED INTELLIGENCE

- Reverse battery protection for both vehicle and breakaway
- Designed to work with electric over hydraulic brake systems
- Numerous mounting options – including 360 degree vertical rotation
- Digital display depicts voltage delivery to trailer during braking
- No level adjustment necessary – it adjusts itself to varying terrain as you drive
- Great for backing into tough spots! Works proportionally in reverse - with the ability to disable when not needed
- Produces stops that are in proportion to vehicle’s deceleration rate
- “Boost” feature gives users the ability to apply more initial trailer braking power when towing heavier trailers
- Continual diagnostics check for proper connection, shorted magnet conditions and much more
- Integrated Plug & Play port for 2-plug adapters
- Pocket-mount allows user to remove and store the control when not in use
- Electric trailer brake control for up to 4 braking axles
- Limited lifetime warranty (some conditions apply)

Part No.	Description	Packaging
90885	Prodigy® P2 Proportional Electronic Trailer Brake Control	Display Box - Tekonsha

PRIMUS^{IQ}



90160

NOTE: Plug & Play feature allows quick and easy connection. It adapts to all Cequent 2-Plug vehicle specific brake control wiring harnesses.



PRIMUSTM IQ THE SMARTER BRAKING SOLUTION

Primus IQ is a totally proportional electric trailer brake control. This easy-to-set system allows the driver maximum flexibility when determining how the trailer should respond to a braking event. Snap-in dash mounting clip and removable electrical connector allow the unit to be quickly stored (or moved to another vehicle) when not in use.

- Works proportionally in reverse
- No level adjustment necessary, adjusts to varying terrain as you drive
- Digital display shows voltage to trailer during braking
- “The Original Boost” feature allows for customized braking
- Integrated Plug & Play port for 2-plug adapters
- Diagnostic features incorporated in LED display
- Electric trailer brake control for up to 3 braking axles
- Snap-in mounting clip allows user to remove and store the control when not in use
- Limited lifetime warranty (some conditions apply)

Part No.	Description	Packaging
90160	Primus TM IQ Proportional Electronic Trailer Brake Control	Display Box - Tekonsha

VOYAGER[®]



9030



VOYAGER[®]

The Voyager incorporates Tekonsha's patented braking sensor and is the best value you'll find for smooth and secure trailer braking. It's compact size and features, like a bicolored LED brake monitor (to assure a complete connection to trailer brakes and give an indication of relative braking power being applied) make the Voyager extremely versatile. Voyager minimizes interference with tow vehicle electrical systems, uses a four wire hook up, has a broad setting range and is compatible with most any vehicle.

- Broad control range makes setting quick and easy
- As braking power is applied, the LED changes color gradually from green (completed circuit) to red, to indicate relative braking power
- Advanced electronics minimize false braking for smoother ride
- Electric trailer brake control for up to 4 braking axles
- Plug & Play feature allows quick and easy connection
- 5-year limited warranty

Part No.	Description	Packaging
9030	Voyager [®] Proportional Electronic Trailer Brake Control	Display Box - Tekonsha



BRAKEMAN® ULTRA

- 1 to 4 axle trailers
- Overload indicator
- Digital output indicator
- “Up-front” manual over-ride control
- Soft touch thumb wheels
- Front display allows viewing at almost any angle
- Stylish upgraded appearance
- Mounts in any position
- No leveling required
- Mounting hardware included
- Integrated Plug & Play port for 2-plug adapters
- Limited lifetime warranty (some conditions apply)



83520

NOTE: Plug & Play feature allows quick and easy connection. It adapts to all Cequent 2-Plug vehicle specific brake control wiring harnesses.

Part No.	Description	Packaging
83520	Brakeman® Ultra Electronic Brake Control	Clam - Reese

BRAKEMAN® DIGITAL

- 1 to 4 axle trailers
- Digital output indicator
- Thumb wheel output adjustment
- Overload indicator
- Plug & Play feature allows quick and easy connection
- Limited lifetime warranty (some conditions apply)



83500

Part No.	Description	Packaging
83500	Brakeman® Digital Brake Control	Clam - Reese

Note: Not recommended for use with BMW X5 Sport Utility Vehicles

BRAKEMAN® COMPACT

- 1 & 2 axle trailers
- Illuminated LED output indicator
- Slide adjustment output control
- Plug & Play feature allows quick and easy connection
- 5 year limited warranty



83501

Part No.	Description	Packaging
83501	Brakeman® Compact Brake Control	Clam - Reese

Note: Not recommended for use with BMW X5 Sport Utility Vehicles



I-STOP™ IQ BRAKE CONTROL FOR 1 TO 3 AXLE TRAILERS

A totally proportional electric trailer brake control, the new Draw-Tite I-Stop™ IQ is self-leveling so no level adjustment is necessary.

Utilizing primary sensor technology the IQ now includes the “Boost” feature that gives users the ability to apply more initial trailer braking when towing heavier trailers. It works proportionally in reverse for backing into tough spots and includes a snap-in dash mounting clip and removable electrical connector that allows the unit to be quickly stored when not in use. You will appreciate the digital readout depicting a secure electrical connection, amount of voltage delivery to the trailer brakes and diagnostic features incorporated in the LED display.

- Integrated Plug & Play port for 2-plug adapters
- Self-diagnostics features will illuminate LED readout when issues occur
- Includes a “Boost” feature
- Works proportionally in reverse
- Snap-in dash mounting clip and hardware included
- Digital LED readout
- Snap-in mounting clip allows user to remove and store the control when not in use
- Limited Lifetime Warranty



NOTE: Plug & Play feature allows quick and easy connection. It adapts to all Cequent 2-Plug vehicle specific brake control wiring harnesses.

Part No.	Description	Packaging
20191	I-Stop™ IQ Proportional Electronic Trailer Brake Control	Display Box - Draw-Tite



ACTIVATOR III BRAKE CONTROL



5520

- 1 to 4 axle trailers
- Overload indicator
- Digital output indicator
- “Up-front” manual over-ride control
- Soft touch thumb wheels
- Front display allows viewing at almost any angle
- Stylish upgraded appearance
- Mounts in any position
- No leveling required
- Mounting hardware included
- Integrated Plug & Play port for 2-plug adapters
- Limited lifetime warranty

Part No.	Description	Packaging
5520	Activator® III Electronic Brake Control	Clam - Draw-Tite

NOTE: Plug & Play feature allows quick and easy connection. It adapts to all Cequent 2-Plug vehicle specific brake control wiring harnesses.

ACTIVATOR II BRAKE CONTROL



5500

- 1 to 4 axle trailers
- Digital output indicator
- Thumb wheel output adjustment
- Overload indicator
- Plug & Play feature allows quick and easy connection
- Limited lifetime warranty
- Attractive point-of-purchase display packaging

Part No.	Description	Packaging
5500	Activator® II Electronic Brake Control	Clam - Draw-Tite

Note: Not recommended for use with BMW X5 Sport Utility Vehicles

ACTIVATOR BRAKE CONTROL



5100

- 1 & 2 axle trailers
- Illuminated LED output indicator
- Slide adjustment output control
- Plug & Play feature allows quick and easy connection
- 5 year limited warranty
- Attractive point-of-purchase display packaging

Part No.	Description	Packaging
5100	Activator® Electronic Brake Control	Clam - Draw-Tite

Note: Not recommended for use with BMW X5 Sport Utility Vehicles



PILOT® BRAKE CONTROL

FOR 1 TO 3 AXLE TRAILERS

The Pilot® has just made owning and operating a digital brake control easier than ever. Because of the flexible mounting options, you are able to mount the Pilot® in any direction. Our microprocessor allows you the ability to read the display even when the Pilot® is mounted upside down. The Pilot's digital display shows voltage output to the brakes with additional protection against short circuit or loss of ground. Capable for handling up to 3 axle trailers.

- Large easy to read dual digital display shows:
 - Properly wired control
 - Voltage output to brakes (vs. a percentage output)
 - Connection to trailer
- Dark smoke lens ideal for direct light applications; performs better than red lens
- Microprocessor allows control to be mounted upside down and still have a readable display
- Protection against short circuit and loss of ground
- Standard mounting bracket and pivot mount included
- For use on any 12 volt negative ground system
- Plug & Play feature allows quick and easy connection
- Limited lifetime warranty

Part No.	Description	Packaging
80550	Pilot® Brake Control	Clam - Pro Series



80550

NOTE: Plug & Play feature allows quick and easy connection. It adapts to all Cequent 2-Plug vehicle specific brake control wiring harnesses.

POD® BRAKE CONTROL

FOR 1 & 2 AXLE TRAILERS

The POD® (Power on Demand) is your best choice for 1 or 2 axle trailers, especially when your installation options are limited. The POD® can be mounted in any direction, and its unique design features “up-front-easy-access” adjustment controls, even when mounted upside down.

- Power-on LED for a positive tow vehicle-to-trailer connection
- “Up-front” manual over-ride control
- Rugged, easy mount chassis
- Mounting hardware included
- Smooth and simple installation
- Solid state electronics
- Plug & Play feature allows quick and easy connection
- 5 year limited warranty

Part No.	Description	Packaging
80500	POD® Brake Control	Clam - Pro Series



80500



5901TEK / 5904



7686



6927



5298



7685B20 / 7685



5280



2178



7894



20127



BRAKE CONTROL ACCESSORIES

Clip / Pivot Mounting

Bulk	Clam	Application	Description
5901TEK		P3 90195	Dash Mounting Clip
5904		P3 90195	Dash Mounting Clip Bracket
5298		Pilot 80550	Dash Pivot Mounting Kit
	7686	Prodigy P2 90885	Dash Pocket Mounting Kit
6927		Primus IQ 90160, I-Stop IQ 20191	Dash Mounting Clip

Traditional Bracket Mounting

Bulk	Clam	Application	Description
	7685	Prodigy P2 90885	Mounting Bracket Kit
5280		Primus IQ 90160, I-Stop IQ 20191, Pilot 80550	Mounting Bracket Only
2178		P3 90195, Voyager 9030, POD 80500	Mounting Bracket Kit

Replacement Wiring Harness

Bulk	Clam	Application	Description
	7894	P3 90195, P2 90885, Primus IQ 90160, I-Stop IQ 20191, 5520 Activator III, 83520 Brakeman Ultra	30" Pigtail Harness Kit
	20127	P3 90195, P2 90885, Primus IQ 90160, I-Stop IQ 20191, 5520 Activator III, 83520 Brakeman Ultra	12" Pigtail Harness



PULSE PREVENTER

Prevents actuation of electronic brake control by 4-way flasher circuit.

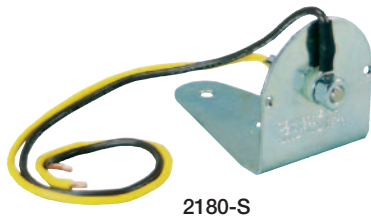

2180-S

Part No.	Description	Packaging
2180-S	Pulse Preventer	Clam - Tekonsha



PULSE PREVENTER

Immunizes against the effects of 4-Way flashers on some brake controls.

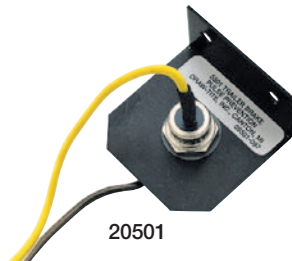

20501

Part No.	Description	Packaging
20501	Pulse Preventer	Clam - Tow Ready



BRAKE MATE™ KIT

Includes all necessary parts required to completely install all brake controls. No other parts are necessary.

Each Brake Mate™ Kit includes:

- Pre-wired 7-Way round connector
- Heavy duty flasher
- Heavy duty breakers (2 pcs.)
- Self tapping screws (8 pcs.)
- Integrated 4-Flat trailer end
- Tie straps (6 pcs.)
- Scotch locks (5 pcs.)
- For simple mounting, choose 7-Way Mounting Box Part Numbers 118156, 118157
- Ring connectors (7 pcs.) or 118159 (sold separately)



118607

Part No.	Description	Packaging
118607	7-Way Brake Mate™ Kit – Flat Pin	Clam - Tow Ready



20505, 20506

BRAKE MATE™ KIT

Part No.	Description	Packaging
20505	Wiring Kit for 1 - 2 Axles Brake Control Systems, Includes 25' 12-2 Duplex Wire, 20 Amp Circuit Breaker and Attaching Terminals	Clam - Tow Ready
20506	Wiring Kit for 3 – 4 Axles Brake Control Systems, Includes 25' 10-2 Duplex Wire, 30 Amp Circuit Breaker and Attaching Terminals	Clam - Tow Ready

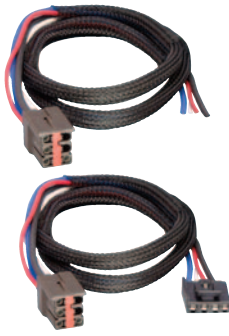

BRAKE CONTROL WIRING HARNESSES

All vehicle specific brake control wiring harnesses are available in 1-Plug or 2-Plug styles.

1-Plug units are designed for brake controls manufactured with electrical wiring mounted on the back of the unit, otherwise known as a pigtail. Wiring harnesses must be spliced into the existing pigtail to allow the vehicle specific plug to be installed.

2-Plug units are designed for brake controls that have a wiring port built into the back of the unit. Simply plug the brake control end of the wiring harness into the back of the brake control and the vehicle end into the automobile's port. Brake controls that utilize the 2-plug style of wiring harness will be identified with the Plug & Play logo.

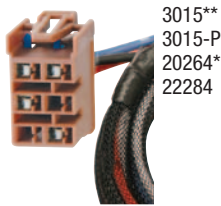
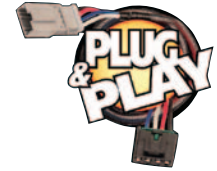

3015**
3015-P
20264*
22284



3020**
3020-P
20261*
22281



3021**
3021-P
20273*
22293



3025**
3025-P
20263*
22283



3026**
3026-P
20269*
22289



3032**
3032-P
20271
22291



3034**
3034-P
20270
22290

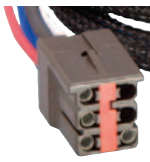

3035**
3035-P
20260*
22280



3036**
3036-P
20272*
22292



3040**
3040-P
20265
22285



3045** *New*
3045-P
20274
22294



3050**
3050-P
20266
22286

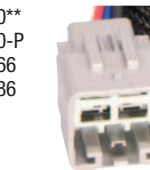

3065**
3065-P
20267*
22287



3070**
3070-P
20268
22288

* Clam and also available in bulk 12-pack. (Ex: 20260-012) ** Bulk 20-pack.

BP1 - Under or behind dash, to the left or right of the emergency brake pedal.

BP2 - Under or behind dash to the left of the steering column and brake pedal.

BP3 - Under or behind dash to the right of the steering column and brake pedal.

BP4 - Kick panel area, on the Driver's side.

BP5 - Under or behind dash, behind the center console.

BP6 - Under or behind dash on the passenger side, near glovebox.

BP7 - Centered behind dash between the steering column and the radio.

VEHICLE SPECIFIC BRAKE CONTROL WIRING HARNESS POSITION

BRAKE CONTROL WIRING HARNESSES APPLICATION GUIDE



Model	Year	POS	1-PLUG CLAM / BULK		2-PLUG CLAM		2-PLUG BULK		2-PLUG CLAM	
			PC	Part No.	PC	Part No.	PC	Part No.	PC	Part No.
BUICK										
Enclave w/Factory 7-Way	08-12	BP1	E1	20269	E3	22289		3026		3026-P
CADILLAC										
Escalade All, Inc. EXT	02	BP1	E1	20263	E3	22283		3025		3025-P
Escalade All, Inc. EXT & ESV	03-06	BP1	E1	20264	E3	22284		3015		3015-P
CHEVROLET										
Avalanche	02	BP1	E1	20263	E3	22283		3025		3025-P
Avalanche	03-06	BP1	E1	20264	E3	22284		3015		3015-P
Pickup, Silverado	99-02	BP1	E1	20263	E3	22283		3025		3025-P
Pickup, Silverado	03-06	BP1	E1	20264	E3	22284		3015		3015-P
Pickup, Silverado Classic Only	07	BP1	E1	20264	E3	22284		3015		3015-P
Suburban	03-06	BP1	E1	20264	E3	22284		3015		3015-P
Suburban New Body Style w/Amber Turn Signals	00-02	BP1	E1	20263	E3	22283		3025		3025-P
Tahoe	03-06	BP1	E1	20264	E3	22284		3015		3015-P
Tahoe New Body Style w/Amber Turn Signals	00-02	BP1	E1	20263	E3	22283		3025		3025-P
Traverse w/Factory 7-Way	09-12	BP1	E1	20269	E3	22289		3026		3026-P
CHRYSLER										
Aspen w/Factory Tow Package	07-09	BP2	E1	20261	E3	22281		3020		3020-P
DODGE										
Dakota Pickup w/Factory Tow Package	97-11	BP2	E1	20261	E3	22281		3020		3020-P
Durango w/Factory Tow Package	98-09	BP2	E1	20261	E3	22281		3020		3020-P
Durango w/Factory Tow Package	11-12	BP2	E1	20274	E3	22294		3045	E3	3045-P
Pickup, Ram, Full Size 1500 Only, All Models	95-09	BP2	E1	20261	E3	22281		3020		3020-P
Pickup, Ram, Full Size 1500 Only, All Models	10-12	BP1	E1	20273	E3	22293		3021	E3	3021-P
Pickup, Ram, Full Size 2500 HD Only, All Models	10-12	BP1	E1	20273	E3	22293		3021	E3	3021-P
Pickup, Ram, Full Size 2500 Only, All Models	95-09	BP2	E1	20261	E3	22281		3020		3020-P
Pickup, Ram, Full Size 3500 HD Only, All Models	10-12	BP1	E1	20273	E3	22293		3021	E3	3021-P
Pickup, Ram, Full Size 3500 Only, All Models	95-09	BP2	E1	20261	E3	22281		3020		3020-P
FORD										
Bronco Full Size	94-96	BP3	E1	20260	E3	22280		3035		3035-P
E-150 Econoline Van Full Size, All Models	92-08	BP3	E1	20260	E3	22280		3035		3035-P
E-150 Econoline Van Full Size, All Models	09-12	BP7	E1	20270	E3	22290		3034		3034-P
E-250 Econoline Van Full Size, All Models	92-08	BP3	E1	20260	E3	22280		3035		3035-P
E-250 Econoline Van Full Size, All Models	09-12	BP7	E1	20270	E3	22290		3034		3034-P
E-350 Econoline Van Full Size, All Models	92-08	BP3	E1	20260	E3	22280		3035		3035-P
E-350 Econoline Van Full Size, All Models	09-12	BP7	E1	20270	E3	22290		3034		3034-P
E-350 Econoline Van RV Cutaway w/Factory Tow Prep Plug	92-08	BP3	E1	20260	E3	22280		3035		3035-P
E-350 Econoline Van RV Cutaway w/Factory Tow Prep Plug	09-11	BP7	E1	20270	E3	22290		3034		3034-P
E-450 Econoline Van RV Cutaway w/Factory Tow Prep Plug	92-08	BP3	E1	20260	E3	22280		3035		3035-P
E-450 Econoline Van RV Cutaway w/Factory Tow Prep Plug	09-11	BP7	E1	20270	E3	22290		3034		3034-P
Excursion	00-05	BP3	E1	20260	E3	22280		3035		3035-P
Expedition	97-11	BP3	E1	20260	E3	22280		3035		3035-P
Explorer w/Factory Tow Package	02-10	BP6	E1	20260	E3	22280		3035		3035-P
Explorer w/Factory Tow Package	11-12	BP2	E1	20260	E3	22280		3035		3035-P
F-150	94-96	BP3	E1	20260	E3	22280		3035		3035-P
F-150 Flareside (New Body Style)	04-08	BP3	E1	20260	E3	22280		3035		3035-P
F-150 Flareside (New Body Style)	09-12	BP3	E1	20272	E3	22292		3036		3036-P
F-150 Styleside (New Body Style)	04-08	BP3	E1	20260	E3	22280		3035		3035-P
F-150 Styleside (New Body Style)	09-12	BP3	E1	20272	E3	22292		3036		3036-P
F-150 Light Duty Flareside	97-03	BP3	E1	20260	E3	22280		3035		3035-P
F-150 Light Duty Styleside	97-03	BP3	E1	20260	E3	22280		3035		3035-P

BRAKE CONTROL WIRING HARNESSES APPLICATION GUIDE



**1-PLUG
CLAM / BULK**

**2-PLUG
CLAM**

**2-PLUG
BULK**

**2-PLUG
CLAM**

Model	Year	POS	PC	Part No.	PC	Part No.	PC	Part No.	PC	Part No.
FORD (Continued)										
F-150 Light Duty Heritage Flareside Old Body Style	04	BP3	E1	20260	E3	22280		3035		3035-P
F-150 Light Duty Heritage Styleside Old Body Style	04	BP3	E1	20260	E3	22280		3035		3035-P
F-150 SuperCrew	97-03	BP3	E1	20260	E3	22280		3035		3035-P
F-150 SuperCrew New Body Style	04-08	BP3	E1	20260	E3	22280		3035		3035-P
F-150 SuperCrew New Body Style, w/5.5 & 6.5 ft. Beds	09-12	BP3	E1	20272	E3	22292		3036		3036-P
F-250	94-96	BP3	E1	20260	E3	22280		3035		3035-P
F-250 Heavy Duty	97	BP3	E1	20260	E3	22280		3035		3035-P
F-250 Light Duty Styleside	97-99	BP3	E1	20260	E3	22280		3035		3035-P
F-250 Super Duty	99-04	BP3	E1	20260	E3	22280		3035		3035-P
F-250 Super Duty	05-07	BP5	E1	20267	E3	22287		3065		3065-P
F-250 Super Duty	08-12	BP3	E1	20270	E3	22290		3034		3034-P
F-350	94-96	BP3	E1	20260	E3	22280		3035		3035-P
F-350 Heavy Duty	97	BP3	E1	20260	E3	22280		3035		3035-P
F-350 Super Duty	99-04	BP3	E1	20260	E3	22280		3035		3035-P
F-350 Super Duty	05-07	BP5	E1	20267	E3	22287		3065		3065-P
F-350 Super Duty	08-12	BP3	E1	20270	E3	22290		3034		3034-P
F-350 Super Duty Cab & Chassis	05-07	BP5	E1	20267	E3	22287		3065		3065-P
F-350 Super Duty Cab & Chassis	08-11	BP3	E1	20270	E3	22290		3034		3034-P
F-450 Super Duty	08-12	BP3	E1	20270	E3	22290		3034		3034-P
F-450 Super Duty Cab & Chassis	99-04	BP3	E1	20260	E3	22280		3035		3035-P
F-450 Super Duty Cab & Chassis	05-07	BP5	E1	20267	E3	22287		3065		3065-P
F-450 Super Duty Cab & Chassis	08-11	BP3	E1	20270	E3	22290		3034		3034-P
F-550 Super Duty Cab & Chassis	99-04	BP3	E1	20260	E3	22280		3035		3035-P
F-550 Super Duty Cab & Chassis	05-07	BP5	E1	20267	E3	22287		3065		3065-P
F-550 Super Duty Cab & Chassis	08-11	BP3	E1	20270	E3	22290		3034		3034-P
Flex w/Factory Tow Package	09-11	BP2	E1	20260	E3	22280		3035		3035-P
Flex w/Factory Tow Package	12	BP3	E1	20272	E3	22292		3036		3036-P
Windstar w/Factory Tow Package	95-03	BP3	E1	20260	E3	22280		3035		3035-P
GMC										
Acadia w/Factory 7-Way	07-12	BP1	E1	20269	E3	22289		3026		3026-P
Pickup, Sierra	99-02	BP1	E1	20263	E3	22283		3025		3025-P
Pickup, Sierra	03-06	BP1	E1	20264	E3	22284		3015		3015-P
Pickup, Sierra Classic Only	07	BP1	E1	20264	E3	22284		3015		3015-P
Yukon	03-06	BP1	E1	20264	E3	22284		3015		3015-P
Yukon New Body Style w/Amber Turn Signals	00-02	BP1	E1	20263	E3	22283		3025		3025-P
Yukon Denali	03-06	BP1	E1	20264	E3	22284		3015		3015-P
Yukon Denali New Body Style w/Amber Turn Signals	01-02	BP1	E1	20263	E3	22283		3025		3025-P
Yukon XL	00-02	BP1	E1	20263	E3	22283		3025		3025-P
Yukon XL	03-06	BP1	E1	20264	E3	22284		3015		3015-P
Yukon XL Denali	01-02	BP1	E1	20263	E3	22283		3025		3025-P
Yukon XL Denali	03-06	BP1	E1	20264	E3	22284		3015		3015-P
HONDA										
Pilot w/Factory Tow Package	09-12	BP1	E1	20268	E3	22288		3070		3070-P
Ridgeline w/Factory Tow Package	06-12	BP1	E1	20268	E3	22288		3070		3070-P
HUMMER										
H2	03-07	BP1	E1	20264	E3	22284		3015		3015-P
H2 SUT	05-07	BP1	E1	20264	E3	22284		3015		3015-P
INFINITI										
QX56	04-11	BP1	E1	20266	E3	22286		3050		3050-P

BRAKE CONTROL WIRING HARNESSES APPLICATION GUIDE



1-PLUG
CLAM / BULK

2-PLUG
CLAM

2-PLUG
BULK

2-PLUG
CLAM

Model	Year	POS	PC	Part No.	PC	Part No.	PC	Part No.	PC	Part No.
JEEP										
Grand Cherokee w/Factory Tow Package	11-12	BP2	E1	20274	E3	22294		3045	E3	3045-P
KIA										
Borrego	09-11	BP4	E1	20271	E3	22291		3032		3032-P
LAND ROVER										
LR3	05-09	BP3	E1	20260	E3	22280		3035		3035-P
LR4	10-11	BP3	E1	20260	E3	22280		3035		3035-P
Range Rover Inc. Sport	05-11	BP3	E1	20260	E3	22280		3035		3035-P
Range Rover Evoque	12	BP2	E1	20260	E3	22280		3035		3035-P
LEXUS										
GX 460	10-11	BP4	E1	20265	E3	22285		3040		3040-P
GX 470	03-09	BP3	E1	20265	E3	22285		3040		3040-P
LX 470	03-07	BP3	E1	20265	E3	22285		3040		3040-P
LX 570	08-11	BP3	E1	20265	E3	22285		3040		3040-P
LINCOLN										
Mark LT	06-08	BP3	E1	20260	E3	22280		3035		3035-P
MKT w/Factory Tow Package	10-12	BP1	E1	20260	E3	22280		3035		3035-P
Navigator	98-11	BP3	E1	20260	E3	22280		3035		3035-P
MERCURY										
Mountaineer w/Factory Tow Package	02-10	BP6	E1	20260	E3	22280		3035		3035-P
NISSAN										
Armada	04-12	BP1	E1	20266	E3	22286		3050		3050-P
Frontier Pickup	05-12	BP3	E1	20266	E3	22286		3050		3050-P
Pathfinder	05-12	BP3	E1	20266	E3	22286		3050		3050-P
Titan Pickup	04-12	BP1	E1	20266	E3	22286		3050		3050-P
SATURN										
Outlook w/Factory 7-Way	07-09	BP1	E1	20269	E3	22289		3026		3026-P
TOYOTA										
4Runner	03-11	BP4	E1	20265	E3	22285		3040		3040-P
LandCruiser	03-11	BP3	E1	20265	E3	22285		3040		3040-P
Sequoia	03-11	BP4	E1	20265	E3	22285		3040		3040-P
Tacoma Pickup	07-12	BP4	E1	20265	E3	22285		3040		3040-P
Tundra	03-12	BP4	E1	20265	E3	22285		3040		3040-P

OUTFITTING YOUR VEHICLE

Top Of Vehicle

Back Of Vehicle

Vehicle Interior



BENEFITS

- Easy to get to roof on small vehicles
- Unobstructed rear view mirror
- Trunk and hatch remain accessible
- Carries multiple accessories at same time (eg. kayak and bike)
- Better protection from salt and road debris

- Fast & easy loading
- Greatest weight carrying capacity
- Less wind resistance (better MPG)
- Can drive into areas with low overhead clearance
- Great for keeping dirty items away from passengers

- Best security
- Protection from the elements
- Less wind resistance (better MPG)
- Organize belongings

BENEFITS

GOOD FOR

- Vehicles with cross bars
- Vehicles which are low to the ground
- People who can lift weight overhead

- Vehicles with hitches
- Vehicles with good ground clearance
- People who have gear which cannot be lifted overhead

- Vehicles with large interiors or trunk areas
- People who frequently transport small items

GOOD FOR

YOU'RE NOT LIMITED TO ONE ZONE!

ROOF RACKS AND ACCESSORIES

- Roof Racks
- Roof Rack Accessories
- Roof Rack Application Guide

BIKE CARRIERS AND ACCESSORIES

- ROLA® Stingray™ Rooftop Bike Carrier
- ROLA® Rooftop Bike Carrier
- Pro Series™ Rooftop Bike Carrier
- ROLA® NV2™ Hitch Mount Bike Carrier
- ROLA® TX™ Hitch Mount Bike Carriers
- ROLA® Stingray™ Bike Carrier Clip
- Pro Series™ SportWing™ Hitch Mount Bike Carriers
- Pro Series™ Translite™ Hitch Mount Bike Carrier
- Pro Series™ Q-Slot 2™ Hitch Mount Bike Carrier
- Pro Series™ Eclipse™ Hitch Mount Bike Carriers
- Pro Series™ Axis 3™ Trunk Mount Bike Carrier
- Bike Carrier Accessories

CARGO BOXES AND ACCESSORIES

- ROLA® Airfoil™ Rooftop Cargo Boxes
- ROLA® Pursuit™ Fold Away Rooftop Luggage Carrier
- Pro Series™ Bullet Rooftop Cargo Box
- ROLA® Hitch Mounted Cargo Boxes

CARGO CARRIERS AND ACCESSORIES

- ROLA® Vortex™ Rooftop Steel Cargo Basket
- Light Duty Rooftop Cargo Carrier
- ROLA® Stingray™ Hitch Mount Cargo Carrier
- ROLA® Vortex™ Hitch Mount Cargo Carriers
- ROLA® Polypropylene Hitch Mount Cargo Carriers
- Pro Series™ Railed Hitch Mount Cargo Carriers
- Pro Series™ Hitch Mount Cargo Carriers
- Pro Series™ Folding Hitch Mount Cargo Carrier
- ATV/Vehicle Cargo Carrier
- Cargo Carrier Accessories
- Pro Series™ Transporter™ System with Ramp
- Pro Series™ Solo™ Cargo Carrier with Ramp Accessory
- Pro Series™ GearCage™ SP Cargo Carrier with Ramp Accessory

CARGO BAGS

- ROLA® Expandable Cargo Bags
- Expandable / Car Top / ATV Cargo Bags

PROTECTION, ORGANIZERS, CARGO BARS AND NETS

- Spare Tire / Car / Motorcycle Covers
- SUV Interior Cargo Guard™
- Cab / Cargo Space Organizers
- Cargo / Hanger Bars
- Pet Barrier
- Cargo / Storage / Tailgate Nets

SECURING

- Ratchet Tie Downs
- Fulton® Marine Tie Downs
- Automotive Ratchet / Cambuckle Tie Downs
- Bungee Cords / Tow Straps / Trailering Tie Downs

RAMPS

- Loading Ramps



ROOF RACKS FOR YOUR VEHICLE

BENEFITS

- Loading and transporting equipment easy & efficiently
- Vehicle specific custom fits
- Lightweight and rust free

BENEFITS

FEATURES

- Fully detachable & lockable models
- Low profile designs
- Stainless steel & aluminum components

FEATURES

ACCESSORIES

Water

- Water craft carrier
- Water craft sling
- Water ski clip/mast holder

Snow

- Snow ski clip holder
- Snow ski & board carrier

Cycling

- Roof mounted bike carriers

ACCESSORIES

VEHICLE SPECIFIC ROOF RACKS & ACCESSORIES!

SPORTS SERIES ROOF RACKS VEHICLE MOUNTING SYSTEMS



RB SERIES - Raised Side Rail Mount
Removable and low profile design for vehicles with factory fitted raised side rails.



RBXL SERIES - Raised Side Rail Mount
Removable design for vehicles with factory fitted raised side rails. Low profile crossbars are fully lockable.



RBU SERIES - Raised Side Rail Mount
Removable Universal fit design with extended bar length for vehicles with factory fitted raised side rails. Crossbars are fully lockable.



REX SERIES - Side Rail Mount, Flush or Raised
Removable design with extended bar length for vehicles with factory fitted raised or flush mount side rails. Fully lockable on the crossbar end caps.



RM SERIES - Bare Roof Mount
Removable design using molded rubber pads and stainless steel hardware.



GTX SERIES - Bare Roof Mount
Removable design using molded rubber pads and stainless steel hardware. Crossbars are fully lockable.



APE SERIES - Anchor Point Mount
Removable design for vehicles with integrated anchor mounting points. Crossbars are fully lockable on the crossbar end caps.



APX SERIES - Anchor Point Mount
Removable design for vehicles with integrated anchor mounting points. Crossbars are fully lockable.



AP-GTX - Anchor Point Mount
Removable design for vehicles with integrated anchor mounting points. Crossbars are fully lockable.

UNIVERSAL CROSSBAR RBU SERIES VEHICLE MOUNTING SYSTEM

Removable design for vehicles with raised side rails. Fully lockable with locks included.

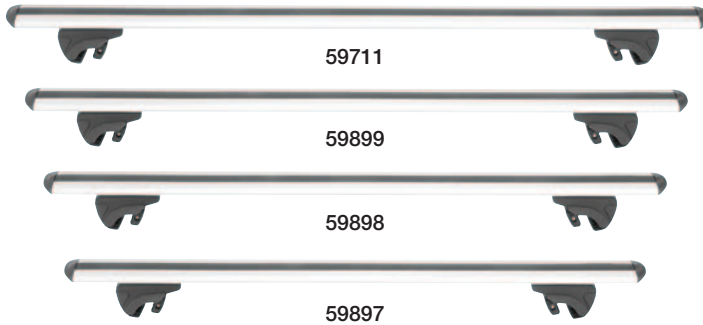

SINGLE PART NUMBER ORDERING

Part No.	Description	Side Rail Fit Range Min.-Max.
59897	Crossbar, End Support & Lock Kit (RBU 1100)	850-1040mm/ 33.5-41"
59898	Crossbar, End Support & Lock Kit (RBU 1200)	950-1140mm/ 37.5-44.8"
59899	Crossbar, End Support & Lock Kit (RBU 1300)	1050-1240mm/ 41.3-48.8"
59711	Crossbar, End Support & Lock Kit (RBU 1400)	1150-1340mm/ 45.3-52.8"

Note: See Application Guide for Vehicle Specific Applications

- Features an aerodynamic extruded aluminum alloy crossbar, minimizing drag and wind noise
- Universal T-slot to mount accessories and locking end caps to prevent theft
- Rubber buffer strips to stabilize and protect the load and the crossbar from being damaged
- Molded reinforced nylon end supports have excellent impact resistance and high tensile characteristics
- Integrated and locking T-handle tool fastens bars to side rails and tightens crossbars with dual action, no tools required
- Stainless steel hardware for long life
- Locks & keys included prevent the roof racks and accessories from being stolen
- Applications to fit most vehicles with raised side rails, some vehicles have optional wider bars to carry even more gear



59711 – Universal Crossbar (RBU 1400 Shown)



Install crossbar on vehicle



Tighten integrated tool handle



Lock to secure



Remove end cap to access accessory T-channel

SEE APPLICATION GUIDE FOR SPORTS SERIES AND RBU SERIES VEHICLE SPECIFIC APPLICATIONS ON PAGE I-39



ROLA® ROOF RACK ACCESSORIES



59404



59875



63130



59876



59877



59878



59600



59879

Part No.	Product Name	Description	Rack Design	Carrying Capacity
Cycling Accessories				
59404	Roof Mounted Bike Carrier New	Transports bikes with standard fork mount wheels. Removable bushings allow for small (5mm) and large (15mm) diameter bike skewers.	Sports	1
59875	Roof Mounted Bike Carrier w/Extension	For carrying bikes with a quick release front wheel, on racks that are not adjustable and the bike's rear wheel needs to sit past the rear crossbar.	Sports	1
63130	Roof Top 1 Bike Carrier Pro Series™	Universal mounting hardware fits round, square & most factory OEM racks. Lockable system secures bike to rack. Tie down straps for wheels included.	Sports	1
Water Accessories				
59876	Multi-Pivot Water Craft Carrier	This ROLA Water Craft Carrier employs a "Multi-Pivot" system to mold to the widest range of displacement hull shapes, as well as providing assistance for loading craft from side of the vehicle. The cradles attach quickly and easily, either directly to the crossbar channel, or via the supplied low-profile adaptor units. Contents of kit will carry 1 watercraft.	Sports	1
59877	Water Craft Carrier Sling	This ROLA Water Craft Sling type carrier which conforms perfectly to any shape hull, providing unmatched support and allowing craft to be safely carried not only in the upright position, but also inverted, or even on their sides - freeing up crossbar area.	Sports	1
59878	Water Ski Clip / Mast Holder	This Ski Clip / Mast Holder - This Water Ski Clip / Mast Holder is designed to quickly fit around the ROLA crossbar and can be used to carry a pair of water skis or a sailboard mast.	Sports	1
Snow Accessories				
59878	Snow Ski Clip	This Ski Clip is designed to quickly fit around the crossbar and carry a pair of skis. It is the most economical way to safely carry skis on your roof racks.	Sports	1
59600	Roof Top Ski & Snow Board Carrier	This ROLA ski carrier holds up to 6 pairs of ski's or 4 snowboards. Universal mounting hardware fits round, square & most factory OEM racks.	Sports	6 pairs of skis 4 snowboards
Tie Down Attachment				
59879	Tie Down Attachment	This accessory allows you to secure your tie down straps or ropes to a fixed point along the rack crossbar. 4 per pack.	Sports	





38374-001



38371



38422



59847



59887

ROLA® ROOF RACK ACCESSORIES

Part No.	Product Name	Description
Accessories / Replacements / Service Kits		
38374-*	Accessory Lock Cores & Keys	Fits ROLA® lockable roof racks and other ROLA accessories. (* specify key/lock core number when ordering)
38373-*	Accessory Keys	Fits ROLA® lockable roof racks and other ROLA accessories (* specify key number when ordering)
59703	Lock Plug	Replacement Part, Quarter Turn Plugs (4)
38371	T-Handle	T-27 Torx Driver Replacement, 2 pcs.
59847	L-Handle	T-27 Torx Driver Replacement, 2 pcs.
38422	Mounting Pads	Mounting Pads, Service Kit for #59842, 4 pcs.
38423	Mounting Pads	Mounting Pads, Service Kit for #59870, 4 pcs.
38424	Mounting Pads	Mounting Pads, Service Kit for #59866, 4 pcs.
38425	Mounting Pads	Mounting Pads, Service Kit for #59800, 4 pcs.
38426	Mounting Pads	Mounting Pads, Service Kit for #59867, 4 pcs.
38427	Mounting Pads	Self-Adhesive Rubber Mounting Pads, Service Kit for RB Series, 4 pcs.
38428	Mounting Pads	Self-Adhesive Rubber Mounting Pads, Service Kit for RBXL Series, 4 pcs.
38429	Mounting Pads	Self-Adhesive Rubber Mounting Pads, Service Kit for GTX Series, 4 pcs.
59846	Buffer Strips	Crossbar Rubber Buffer Strips, Service Kit for Roof Racks, 2 pcs.
59701	Security Bolts	Replacement Roof Rack Security Bolts, 4 pcs., M6 x 30mm
59702	Security Bolts	M6 x 50mm
59887	Cover Kit	GTX Series Support Cover Kit (Includes: (1) Left Hand Cover, (1) Right Hand Cover, (2) Hinges & (2) Dummy Locks - keyed locks not included)
59886	Cover Kit	RBXL Series Support Cover Kit (Includes (2) Locking Covers)
59710	Cage Nuts	Cage Nuts M6-1 (4)



BIKE CARRIERS FOR YOUR VEHICLE

STYLE

Bicycle Type: Recommended Racks

- Traditional bikes: Any (except fork mount)
- Removeable front wheel: Roof top fork mount
- Beach Cruiser: Wheel mount
- Non-standard frame: Wheel mount or frame mount (single arm)
- BMX & Youth: Wheel mount
- Woman's: Wheel mount
- Tandem: Wheel mount (hitch, trunk & roof top)
- More than 4 bikes: Combination
- Beach Cruiser: Wheel mount

STYLE

ACCESSORIES

Shank Extension

- Vehicles with spare tires on back
- Vehicles with recessed receiver hitches

Silent Hitch Pin

- Hitch mounted bike racks

Locks

- Securing bikes to rack
- Securing rack to vehicle

ACCESSORIES

BIKE CARRIERS AND ACCESSORIES FOR ANY CONFIGURATION!



New

HITCH / ACCESSORY - RATING GUIDE

Scan this barcode with your mobile phone to access:
www.cequentgroup.com/accessrating.asp



New
Spring 2012



ROLA® STINGRAY™ ROOFTOP BIKE CARRIER



- Transports bikes with standard fork mount wheels
- Removable bushings allow for small (5mm) and large (15mm) diameter bike skewers
- Works with bikes with front wheel disc brakes
- Adjustable for children's and adult bikes up to 50" long (fork to center of rear tire)
- Lightweight aluminum construction will not rust
- Fits crossbar spacing of 700mm (27.5") and up to 1050mm (41.3")
- Universal clamping design includes security bolts and fits all aftermarket cross-bars as well as OEM styles

Part No.	Description
59404	Stingray™ Rooftop Bike Carrier, 40 lbs. (18 kgs) Capacity

Patent Pending.



59875

ROLA® ROOF RACK MOUNT BIKE CARRIER



For carrying bikes with a quick release front wheel, on racks that are not adjustable and the bike's rear wheel needs to sit past the rear crossbar.

Part No.	Description
59875	Roof Rack Accessory, Bike Carrier, 1 Bike, w/Extension (Only for ROLA® Roof Racks)

Note: Works only with ROLA brand cross bars.



63130

ROOF TOP 1 BIKE CARRIER

- Universal mounting hardware fits round, square & most factory OEM racks
- Lockable system secures bike to rack
- Tie down straps for wheels included
- Attractive point-of-purchase display packaging



Part No.	Description
63130	Roof Top 1 Bike Carrier



ROLA[®]
 Built for *Extremes* Designed for Everyday Life[®]

ROLA[®] NV2[™] BIKE CARRIER

- Fits all bikes
- Adjustable to fit both adult and children's bike sizes
- Fits both 1-1/4" and 2" receivers
- Light weight aluminum support arms
- Security loop provides attachment point to secure your bikes to carrier
- Protective foam pads protect bicycle frame and rims



Part No.	Description	Shank Length	Mount	Class
59508	NV2 [™] , 2 Bike Carrier	—	1-1/4" or 2" Receiver	I/II or III/IV

Patent Pending.

Accessory / Replacement Parts



63232

Part No.	Description
59514	Service Kit NV2, Cradle Assembly/Straps (2RH, 2LH, 2Anti-Sway)
59513	Rise Shank Adapter, 4-1/4" Rise for 1-1/4" Sq. Receivers
59512	Replacement Part, Bike Carrier Arm Tube Caps (2) for 59508
63232	Silent Hitch Pin w/Lock & Wrench, 5/8" for 2" Sq. Receivers
63232-025	Silent Hitch Pin w/Lock & Wrench, 5/8" for 2" Sq. Receivers (25 pack)
63146	Silent Hitch Pin w/Handle & Clip, 5/8" for 2" Sq. Receivers
63145-025	Silent Hitch Pin w/Clip, 5/8" for 2" Sq. Receivers (25 pack)



ROLA® TX™ BIKE CARRIERS



- Dual folding arms allow compact storage when not in use
- Integrated retractable cable lock for improved bike security
- Anti-sway device reduces bike frame sway while traveling
- Tilt feature allows easy trunk access and unloading of bikes
- Soft rubber cradles are gentle on bike frame
- Attractive point-of-purchase display packaging
- The convenience of folding arms and the security of an integrated cable lock

**NOTE: Cannot be used with Class I hitches.*

Part No.	Description	Shank Length	Mount	Class
59400	TX-102, 2 Bike Carrier	—	1-1/4" or 2" Receiver	I/II or III/IV
59403	TX-103, 3 Bike Carrier	6"	1-1/4" or 2" Receiver	I/II or III/IV
59401*	TX-104, 4 Bike Carrier	—	2" Receiver	III/IV

DO NOT USE THESE BIKE CARRIERS ON A TOW TRAILER OR 5TH WHEEL RV

Accessory / Replacement Parts

Part No.	Description
59405	Replacement Part, TX Rubber Strap for 59400, 59403 or 59401
59406	Replacement Part, TX Cradle for 59400, 59403 or 59401
59407	Replacement Part, TX Anti Sway Cradle for 59400, 59403 or 59401
59513	Rise Shank Adapter, 4-1/4" Rise for 1-1/4" Sq. Receivers
63232	Silent Hitch Pin w/Lock & Wrench, 5/8" for 2" Sq. Receivers
63232-025	Silent Hitch Pin w/Lock & Wrench, 5/8" for 2" Sq. Receivers (25 pack)
63146	Silent Hitch Pin w/Handle & Clip, 5/8" for 2" Sq. Receivers
63145-025	Silent Hitch Pin w/Clip, 5/8" for 2" Sq. Receivers (25 pack)



59400

59403

63232

ROLA® STINGRAY™ BIKE RACK CLIP

- Converts the ROLA® Vortex™ and Stingray™ cargo carriers into a fork mounted bike carrier
- Transports most styles of bikes with standard fork mount front wheels
- Removable bushings allow for small (5mm) and large (15mm) diameter bike skewers
- Works with bikes with front wheel disc brakes
- Includes a set of 1 rail clip and rear wheel tie down

Part No.	Description
59904	Stingray™ Bike Rack Clip

Patent Pending.



59904



New
Spring 2012



Converts Cargo Carrier into Bike Carrier
Shown with 59550, Stingray™ Cargo Carrier



SPORTWING™ BIKE CARRIERS

- Bikes are supported by the wheel, not the frame
- Adjustable to fit both adult and children's bike sizes
- Carry multiple bike styles at the same time
- Models available with aluminum or steel support arms
- Quick release cradle and wheel straps
- Removable support arms for compact storage
- Easy to assemble
- Wheel and pedal straps reduce bike sway
- Durable powder coated steel shank



5801200



1370100



SPORTWING™ 2 BIKE CARRIERS

Part No.	Description	Mount	Class
5801200	SportWing™, Aluminum 2 Bike Carrier	1-1/4" or 2" Receiver	I/II or III/IV
1370100	SportWing™, Steel 2 Bike Carrier	1-1/4" Receiver	I/II
1370800**	SportWing™, Accessory Shank with 4" Rise	1-1/4" Receiver	I/II

** Works only with #5801200 and #1370100 Bike Carriers. Patent Pending.

SPORTWING™ 4 BIKE CARRIERS

- Telescoping design
- Rise shank
- Can be used as a 2 bike carrier

Part No.	Description	Mount	Class
1370500	SportWing™, Steel 4 Bike Carrier	2" Receiver	III/IV
1370400	SportWing™, Aluminum 4 Bike Carrier	2" Receiver	III/IV

Patent Pending.

Accessory / Replacement Parts

Part No.	Description
58400	Replacement Part, Bike Carrier Strap for 1370100, 1370400, 1370500, 5801200
58401	Replacement Part, Bike Carrier Cradles w/Straps for 1370100, 1370400, 1370500, 5801200
63232	Silent Hitch Pin w/Lock & Wrench, 5/8" for 2" Sq. Receivers
63232-025	Silent Hitch Pin w/Lock & Wrench, 5/8" for 2" Sq. Receivers (25 pack)
63146	Silent Hitch Pin w/Handle & Clip, 5/8" for 2" Sq. Receivers
63145-025	Silent Hitch Pin w/Clip, 5/8" for 2" Sq. Receivers (25 pack)



1370400



1370500



1370800



63232



New



63144

TRANSLITE™ BIKE CARRIER

- A great 4 bike carrier value!
- Narrow arms fit more bike styles
- Dual rear reflectors for nighttime visibility
- Removable arms for compact storage
- Anti-rattle pin included to reduce sway
- Fold down vertical post for access to rear of vehicle

Part No.	Description	Mount	Class	Capacity
63144	Translite™ 4 Bike Carrier	1-1/4" or 2" Receiver	VI or III/IV	120 lbs.

Patent Pending.

Accessory / Replacement Parts

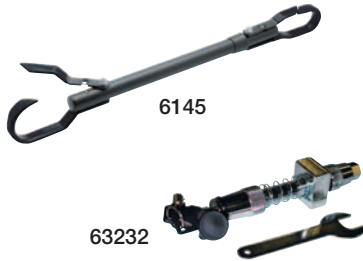

6145

63232

Part No.	Description
6145	Adapter, Y-Frame for Bike Carrier
63232	Silent Hitch Pin w/Lock & Wrench, 5/8" for 2" Sq. Receivers
63232-025	Silent Hitch Pin w/Lock & Wrench, 5/8" for 2" Sq. Receivers (25 pack)
63146	Silent Hitch Pin w/Handle & Clip, 5/8" for 2" Sq. Receivers
63145-025	Silent Hitch Pin w/Clip, 5/8" for 2" Sq. Receivers (25 pack)



63134

Q-SLOT 2™ BIKE CARRIER

- Carries most bikes, regardless of frame style
- Wheel slots adjust for childrens and adult bikes
- Center tube tilts for rear bike loading and unloading
- 1-1/4" shank with 2" adaptor included
- Folds for compact storage
- Rise shank provides extra road clearance for small cars
- E-coat and power coat rust resistant finish

Part No.	Description	Mount	Class	Capacity
63134	Q-Slot 2™ Bike Carrier	1-1/4" or 2" Receiver	VI or III/IV	90 lbs.

Accessory / Replacement Parts



Part No.	Description
63135	Replacement Part, Bike Carrier Hook & Loop Straps for 63134



ECLIPSE™ HITCH MOUNTED BIKE CARRIERS

Traditional, sport, mountain, racing, men's and women's; no matter the type or style of bike being transported, Pro Series™ offers a wide variety of bike carriers to fit your needs. Designed with stylish function, these carriers have everything you would expect from an industry leader.

- 2, 3 & 4 bike carriers
- Padded cradles to protect bikes
- Fits most sizes & styles of bicycles
- Models to fit 1-1/4" & 2" receiver hitches

2 BIKE CARRIERS

63120

The 2 bike fold down rail rack is the solution to carrying extreme bike frames. Now it is possible to carry: Y-Bikes, Beam Bikes, Monocoque frames, steeply sloping top tubes, etc. Locking upright bike supports help prevent theft.

63132

This rugged economy ball mount model carries up to 2 bikes. The ball mount foot allows for installation on Class II, III or IV hitches.

Part No.	Description	Shank Length	Mount	Class
63120	Fold Down Carrier	11-1/2"	1-1/4" Receiver	I/II
63132	Ball Mount Model	—	Universal 3/4" hole	II/III/IV

3 BIKE CARRIER

Strong, durable and versatile and includes a soft cradle surface to hold the bikes securely in place. Generous spacing between the large "v" cradles allows for easy loading and ample distance separating the bikes during transportation.

NOTE: Cannot be used with Class I hitches

Part No.	Description	Shank Length	Mount	Class
63123	Fold Down Carrier - 2 piece	10-1/2" or 11-1/2"	1-1/4" or 2" Receiver	II/III/IV

4 BIKE CARRIERS

These versatile 4 bike carriers are very easy to use and assemble in minutes. The rugged folding models provide easy access to the rear of the vehicle. The fold down towing rack allows you to carry up to 4 bikes while towing your personal watercraft, boat or trailer. All models include a soft cradle surface to hold the bikes securely in place. Generous spacing between the large "v" cradles allows for easy loading and ample distance separating the bikes during transportation.

NOTE: Cannot be used with Class I hitches

Part No.	Description	Shank Length	Mount	Class
63124	Fold Down Carrier - 2 piece	8"	2" Receiver	III/IV
63125*	Fold Down Towing Carrier	5-3/4"	2" Receiver	III/IV

**Use of this towing bike carrier reduces the hitch tow rating by 50%, with a maximum of 3,500 lbs. towing capacity.*

Accessory / Replacement Parts

Part No.	Description
59513	Rise Shank Adapter, 4-1/4" Rise for 1-1/4" Sq. Receivers for 63123
63148	Replacement Part, Bike Carrier Cradle for 63120, 63123, 63124
63232	Silent Hitch Pin w/Lock & Wrench, 5/8" for 2" Sq. Receivers
63232-025	Silent Hitch Pin w/Lock & Wrench, 5/8" for 2" Sq. Receivers (25 pack)
63146	Silent Hitch Pin w/Handle & Clip, 5/8" for 2" Sq. Receivers
63145-025	Silent Hitch Pin w/Clip, 5/8" for 2" Sq. Receivers (25 pack)

DO NOT USE THESE BIKE CARRIERS ON A TOW TRAILER OR 5TH WHEEL RV



63120



63132



63123



63124



63125

63232



1370600

AXIS 3™ BIKE CARRIER

- Fits most cars, vans and SUVs
- Arched support tubes to fit vehicles with spoilers
- Sliding cradles for easier bike loading
- Six straps provide stable and secure attachment to vehicle



Part No.	Description
1370600	AXIS 3™ Trunk mount bike carrier

Patent Pending.



6505

BIKE CARRIER ACCESSORIES

Part No.	Description
6505	Bike Rack Adapter for 6500, 6501 Cargo Carrier
59513	Rise Shank Adapter, 4-1/4" Rise for 1-1/4" Sq. Receivers
1370300	Shank Adapter, Permits Use of 1-1/4" Accessories in 2" Receivers
6145	Adapter, Y-Frame for Bike Carrier
63232	Silent Hitch Pin w/Lock & Wrench, 5/8" for 2" Sq. Receivers
63232-025	Silent Hitch Pin w/Lock & Wrench, 5/8" for 2" Sq. Receivers (25 pack)
63146	Silent Hitch Pin w/Handle & Clip, 5/8" for 2" Sq. Receivers
63145-025	Silent Hitch Pin w/Clip, 5/8" for 2" Sq. Receivers (25 pack)



6145



63232



1370300

CARGO BOXES FOR YOUR VEHICLE

Roof Top

- Haul gear without losing interior vehicle space
- Easy to get to roof on small vehicles
- Low profile, aero-neutral design
- Unobstructed rear view mirror
- Trunk and hatch remain accessible
- Great for keeping dirty items away from passengers
- Weather tight models

Back Of Vehicle

- Haul gear without losing interior vehicle space
- Fast & easy loading
- Greatest weight carrying capacity
- Less wind resistance (better MPG)
- Can drive into areas with low overhead clearance
- Great for keeping dirty items away from passengers

GOOD FOR

- Vehicles with crossbars
- Vehicles which are low to the ground
- People who can lift weight overhead

GOOD FOR

- Vehicles with hitches
- Vehicles with good ground clearance
- People who have gear which cannot be lifted overhead

EXTERIOR ENCLOSED STORAGE FOR ALL YOUR GEAR!



59150

ROLA® PURSUIT™ FOLD AWAY LUGGAGE CARRIER



WHEN IN USE

- 2 pc. lightweight aluminum frame and rugged rainproof construction
- Size in use: 57" x 33" x 17"

WHEN NOT IN USE, JUST 3" HIGH

- Folds flat to reduce wind drag
- Rainproof cover keeps carrier clean and secure
- Universal mounting hardware fits round, square & most factory OEM racks

Part No.	Description
59150	Pursuit™ Fold Away Luggage Carrier (13.5 cu. ft.)



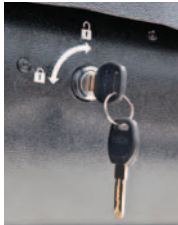

ROLA® AIRFOIL™ ROOFTOP CARGO BOXES

The cargo management solution for convenient vehicle rooftop storage.

- Airfoil SK™ has 16 cu.ft. (92" X 30" X 15") of storage space, holds up to 8 pairs of skis or up to 5 snowboards
- Airfoil LG™ has 12 cu.ft. (54" X 35" X 15") of storage space to hold luggage of multiple sizes
- Very low profile makes parking in garages possible*
- 16" opening for easy loading
- Neutral airfoil design reduces turbulence, creating a quiet and stable ride
- Vortex generators break up turbulence and reduces air buffeting
- Contoured outline allows vehicle hatches to open freely
- Nose buckle maintains closure in high wind
- Keyed lock with ice cover included
- Cross braced floor for added stability
- Constructed of UV Protected ABS for longevity, pebbled finish reduces the appearance of scratches
- Fits cross bar spaces of 26-3/4" to 37-1/2"

Part No.	Description
59003	Airfoil SK™ Cargo Box 16 cu. ft. and 110 lbs. Capacity
59004	Airfoil LG™ Cargo Box 12 cu. ft. and 110 lbs. Capacity

* Always double check your combined vehicle, roof rack and box height against the available vertical clearance.

BULLET BOX™

Pro Series™ offers an economical alternative for convenient vehicle rooftop storage.



New

- Tough ABS material handles all weather extremes
- Pebbled finish reduces the appearance of scratches
- Weather tight protection
- Keyed lock included
- Tall profile and 16" opening makes this roof top box easy to load.
- Holds skis and snowboards up to 180cm
- Size: 72" x 24" x 17"

Part No.	Description
63150	Bullet Box™ 13 cu. ft. & 110 lbs. Capacity



MODULAR LUGGAGE CARRIER



ROLA® ADVENTURE SYSTEM



- A lockable modular storage pod and cargo tray designed to fit 1-1/4" or 2" receivers
- Swing or non-swing away options available
- Swing-away feature provides easy trunk access
- 13.5 cu. ft. storage capacity
- Weather resistant
- Usable tray surface area 49" x 21"
- Up to 250 lbs. load capacity
- Tail lights included

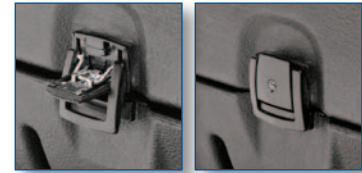
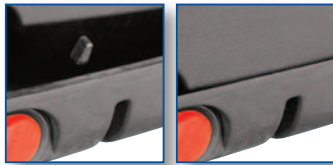

1). Angle pod into tray

2). Insert key into groove

3). Lay pod down into tray

4). Close the latches and you're done



59108



59109

Part No.	Description	Mount	Class
59108	Adventure System 1-1/4" Non-Swing and Tilt with Tray and Pod	1-1/4" Receiver	II
59109*	Adventure System 2" Swing-Away, Tray with Pod	2" Receiver	III/IV
59110*	Adventure System 2" Tilt, Non-Swing Tray and Pod	2" Receiver	III/IV

* UPS oversized - special shipping charges apply
Patent Pending.

Accessory / Replacement Parts

Part No.	Description
59117	Adventure System License Plate Light Kit
59510	Adventure System Replacement Latch Kit
20174	Light Kit for Cargo Carrier, contains 6" Oval Tail Lights, 4-Flat Wiring Harness
59516	LED Light Kit for Cargo Carrier, contains 6" Oval Tail Lights, 4-Flat Wiring Harness



20174



59516



38173



ROLA® ADVENTURE SYSTEM FOR RV ACCESSORY RECEIVERS

- A lockable modular storage box and cargo tray designed to fit 1-1/4" RV Accessory receivers with 3/8" pin holes.
- 13.5 cu. ft. storage capacity
- Weather resistant
- Usable tray surface area 49" x 21"

NOTE: Use only with RV accessories receiver hitch with 3/8" pin hole

Part No.	Description
38173	Adventure System for RV Accessory Hitch Using 3/8" Pin Hole (Includes Tray w/Lights, Pod & 1-1/4" Assy.)

Patent Pending.



59105



59106

ROLA® GEARSPEACE™ 34 CARGO CARRIERS



All-in-one solution for hauling all your gear with 34 cubic feet of enclosed storage. Telescopes for rear vehicle access with dual tube design for strength and stability. Two silent hitch pins are included for rattle-free performance.

- Fits 2" receiver style hitches (Class III/IV)
- 34 cu. ft. of storage capacity
- Weatherproof, automotive elastomer & corrosion-proof latches provide tight lid fit
- TwinTube™ telescoping design allows carrier to slide away from vehicle
- Includes LED taillights w/license plate holder
- Stainless steel lock for security
- Includes two silent hitch pins
- 300 lbs. load capacity
- Available in light or dark gray

Part No.	Description
59105	GearSpace™ 34 Cargo Carrier w/TwinTube™, Light Gray (34 cubic ft.) (Includes Silent Hitch Pin)
59106	GearSpace™ 34 Cargo Carrier w/TwinTube™, Dark Gray (34 cubic ft.) (Includes Silent Hitch Pin)

Accessory / Replacement Parts

Part No.	Description
5802400	Replacement Part, 52" TT (TwinTube™) 2" Sq. Receiver Mount Assembly (Includes Silent Hitch Pin)



CARGO CARRIERS FOR YOUR VEHICLE

Standard

- Side rails with tie down points
- Up to 20" deep (hitch only)
- Road trips, sporting equipment, coolers, luggage, camping equipment

Heavy Duty

- Up to 6" side rails reduces shifting cargo
- Up to 23" deep
- Generators, tool boxes, concrete mix, building/landscape supplies

Ramped

- Easy loading of wheeled equipment
- 32" deep
- Lawn mowers, spreaders, snowblowers, wheelchairs, scooters

IDEAL USE

IDEAL USE

Light Kits

- Provides braking, signal & running lights when gear blocks vehicle lights

Bags

- Protect against road dust & grime. Some provide protection against rain.

Cargo Nets & Tie Downs

- Nets, bungees, and tie downs secure gear.
- Eliminates the rattle between the basket shank & the hitch receiver.

ACCESSORIES

ACCESSORIES

TRANSPORT YOUR GEAR ON A CARGO CARRIER & NOT INSIDE YOUR VEHICLE!



59504



59505



59100



59200

ROLA® VORTEX™ ROOF MOUNTED 2-PIECE STEEL CARGO BASKET



- Sporty 2-piece construction includes easy to fit custom air deflector
- Universal mounting hardware fits round, square & most factory OEM racks
- Black powder coat finish for long lasting durability
- Weighs only 38 lbs. (includes all mounting hardware)
- Size: 48" x 37.5" x 4" (inside dimensions)



Part No.	Description
59504	Vortex™ Roof Mounted 2-Piece Steel Cargo Basket
59505	Vortex™ Roof Mounted Steel Cargo Basket 18-3/4" Extension

NOTE: Do not exceed the vehicle manufacturer's roof rail weight ratings.

Accessory / Replacement Parts

Part No.	Description
59506	Replacement Hardware for #59504
59100	Platypus® Expandable Roof Top Bag (10 to 15 cubic ft.)
59200	Flat Strap Cargo Net - 36" x 48"



3503600

LIGHT DUTY ROOFTOP CARGO CARRIER



- For compact through full size cars, SUVs and vans
- Easy to install and remove, storage space only when needed
- Adjustable straps and non-mar coated hooks included
- Basket carrier folds for easy and compact storage

Part No.	Description
3503600	Light Duty Rooftop Cargo Carrier (49.5" x 37" x 7")

New
Spring 2012



59550

Shown with optional 59904
Bike Carrier Clip



63232



20174



59516

ROLA® STINGRAY™ CARGO & BIKE CARRIER



- Our best cargo carrier yet!
- Conveniently placed lift handle folds this basket to an upright position for easy parking and maneuvering when not in use
- Carefully crafted for superior appearance and performance
- 56" x 23" x 5.25"
- Signature skid and side plates are constructed of heavy duty ABS
- Rise shank included for added ground clearance
- Built-in license plate relocation holes
- Optional bike clips and fully functioning lighting systems available

Part No.	Description	Mount	Class
59550	Stingray™ Cargo Carrier, 600 lbs. Capacity 3 Bikes	2" Receiver	III/IV

Patent Pending.

Accessory / Replacement Parts

Part No.	Description
59904	Stingray™ Bike Carrier Clip, Converts Cargo Carrier to Bike Carrier (order 1/bike)
59516	LED Light Kit for Cargo Carrier, contains 6" Oval Tail Lights, 4-Flat Wiring Harness
20174	Light Kit for Cargo Carrier, contains 6" Oval Tail Lights, 4-Flat Wiring Harness
63232	Silent Hitch Pin w/Lock & Wrench, 5/8" for 2" Sq. Receivers
63232-025	Silent Hitch Pin w/Lock & Wrench, 5/8" for 2" Sq. Receivers (25 pack)
63146	Silent Hitch Pin w/Handle & Clip, 5/8" for 2" Sq. Receivers
63145-025	Silent Hitch Pin w/Clip, 5/8" for 2" Sq. Receivers (25 pack)



New

HITCH / ACCESSORY - RATING GUIDE

Scan this barcode with your mobile phone to access:
www.cequentgroup.com/accessrating.asp



59502

Shown with optional
59904 Bike Carrier Clip and
59516 LED Light Kit

ROLA® VORTEX™ HITCH MOUNTED CARGO CARRIERS

- Up to 600 lbs. load capacity
- Two models to fit 1-1/4" & 2" receivers (Class II - IV)
- Rise shank to elevate cargo carrier above exhaust outlet
- Attachment points to relocate vehicle license plate
- Optional light kit available (#20174 & #59516 LED)
- Size: 56" x 23" x 5.25" (inside dimensions)



Part No.	Description	Mount	Class
59502	Vortex™ Cargo Carrier, 600 lbs. Load Capacity 3 Bikes	2" Receiver	III/IV
59507	Vortex™ Cargo Carrier, 300 lbs. Load Capacity 3 Bikes	1-1/4" Receiver	II

Accessory / Replacement Parts

Part No.	Description
59520	Replacement Hardware for 59502
20049-050	Replacement Part, Light Kit Harness 40100, 40101, 59502, 15100, 15101, 63152, 63153
20174	Light Kit for Cargo Carrier, contains 6" Oval Tail Lights, 4-Flat Wiring Harness
59516	LED Light Kit for Cargo Carrier, contains 6" Oval Tail Lights, 4-Flat Wiring Harness
59904	Stingray™ Bike Carrier Clip, Converts Cargo Carrier to Bike Carrier (order 1/bike)
59102	Wallaroo™ Expandable Cargo Bag (9-1/2 to 11-1/2 cubic ft.)
63232	Silent Hitch Pin w/Lock & Wrench, 5/8" for 2" Sq. Receivers
63232-025	Silent Hitch Pin w/Lock & Wrench, 5/8" for 2" Sq. Receivers (25 pack)
63146	Silent Hitch Pin w/Handle & Clip, 5/8" for 2" Sq. Receivers
63145-025	Silent Hitch Pin w/Clip, 5/8" for 2" Sq. Receivers (25 pack)



59102



63232



20174



59516



59500



ROLA® POLYPROPYLENE CARGO CARRIER

- 400 lbs. capacity
- 53" x 19" (inside dimensions) cargo platform
- Weighs only 35 lbs.
- 2 piece construction bolts together in minutes
- 4" rise shank to elevate cargo tray above exhaust outlet
- Attractive point-of-purchase display packaging

Part No.	Description	Mount	Class
59500	Polypropylene Cargo Carrier	2" Receiver	III/IV

Accessory Parts

Part No.	Description
59200	Flat Strap Cargo Net - 36" x 48"
59102	Wallaroo™ Expandable Cargo Bag (9-1/2 to 11-1/2 cubic ft.)
63232	Silent Hitch Pin w/Lock & Wrench, 5/8" for 2" Sq. Receivers
63232-025	Silent Hitch Pin w/Lock & Wrench, 5/8" for 2" Sq. Receivers (25 pack)
63146	Silent Hitch Pin w/Handle & Clip, 5/8" for 2" Sq. Receivers
63145-025	Silent Hitch Pin w/Clip, 5/8" for 2" Sq. Receivers (25 pack)



59102

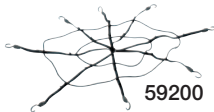

59200



63232



7507

ROLA® FOLDING COMPOSITE CARGO CARRIER

- 400 lbs. capacity
- 53" x 19" (inside dimensions) cargo platform
- Weighs only 35 lbs.
- 2 piece construction bolts together in minutes
- 4" rise shank to elevate cargo tray above exhaust outlet
- Attractive point-of-purchase display packaging

Part No.	Description	Mount	Class
7507	Folding Composite Cargo Carrier, 22" x 56" Platform, 2" Sq. Receiver Mount, 400 lbs. Capacity	2" Receiver	III/IV

Accessory Parts

Part No.	Description
59200	Flat Strap Cargo Net - 36" x 48"
59102	Wallaroo™ Expandable Cargo Bag (9-1/2 to 11-1/2 cubic ft.)
63232	Silent Hitch Pin w/Lock & Wrench, 5/8" for 2" Sq. Receivers
63232-025	Silent Hitch Pin w/Lock & Wrench, 5/8" for 2" Sq. Receivers (25 pack)
63146	Silent Hitch Pin w/Handle & Clip, 5/8" for 2" Sq. Receivers
63145-025	Silent Hitch Pin w/Clip, 5/8" for 2" Sq. Receivers (25 pack)



59102

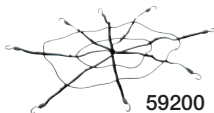

59200



63232



RAILED CARGO CARRIERS



63152



63153

Shown with optional 59904
Bike Carrier Clip

- Up to 500 lbs. capacity
- Up to 60" x 24" (inside dimensions) cargo platform
- Mesh floor for easy cleanup
- 5.5" (inside dimensions) side rails to retain cargo
- Attachment holes for load securing devices
- Optional light kit available (#20174 & #59516 LED)
- Black powder coat finish resists corrosion
- Available in one piece or bolt together designs

Part No.	Description	Mount	Class
63153	Hitch Mounted Carrier, 60" x 24" (I.D.), 500 lbs. Capacity - Bolt Together	2" Receiver	III/IV
63155	Hitch Mounted Carrier, 48" X 20" (I.D.), 300 lbs. Capacity - Bolt Together	1-1/4" Receiver	II
63152	Hitch Mounted Carrier, 60" x 23" (I.D.), 500 lbs. Capacity	2" Receiver	III/IV
63154	Hitch Mounted Cargo Carrier, 48 X 20" (I.D.), 300 lbs. Capacity	1-1/4" Receiver	II

Accessory / Replacement Parts



20174

63232

103970

59516

Part No.	Description
63160	Replacement Hardware for 63152, 63153, 63154, 63155
20049-050	Replacement Hardware for 63152, 63153, 63154, 63155
20174	Light Kit for Cargo Carrier, contains 6" Oval Tail Lights, 4-Flat Wiring Harness
59516	LED Light Kit for Cargo Carrier, contains 6" Oval Tail Lights, 4-Flat Wiring Harness
59904	Stingray™ Bike Carrier Clip, Converts Cargo Carrier to Bike Carrier (order 1/bike)
1039700	Cargo Bag
63232	Silent Hitch Pin w/Lock & Wrench, 5/8" for 2" Sq. Receivers
63232-025	Silent Hitch Pin w/Lock & Wrench, 5/8" for 2" Sq. Receivers (25 pack)
63146	Silent Hitch Pin w/Handle & Clip, 5/8" for 2" Sq. Receivers
63145-025	Silent Hitch Pin w/Clip, 5/8" for 2" Sq. Receivers (25 pack)

CARGO CARRIERS



1040000

- Up to 500 lbs. load capacity
- Black powder coat finish resists corrosion
- Two piece construction, bolts together in minutes
- Convenient attachment points to relocate vehicle license plate
- Includes side corner reflector tape
- Includes 5/8" pin & clip
- Optional light kit available (#6504)



63232



6504



1041700

Part No.	Description	Mount	Class
1040000	Packer™ Hitch Mounted Carrier, 60" x 20" x 2-1/2", 500 lbs. Capacity	2" Receiver	III/IV
1040300	Packer™ 2 Hitch Mounted Carrier, 60" x 20" x 2-1/2", up to 500 lbs. Capacity Includes 1/2" and 5/8" Pin and Clip	2" Receiver - (500 lbs. cap.) 1-1/4" Receiver - (300 lbs. cap.)	III/IV

Accessory / Replacement Parts

Part No.	Description
6504	Light Kit for Cargo Carrier, contains Lights, 4-Flat Wiring Harness and License Plate Bracket
1041700	13 cu. ft. Rain Proof Cargo Bag (54" x 20" x 21")
63232	Silent Hitch Pin w/Lock & Wrench, 5/8" for 2" Sq. Receivers
63232-025	Silent Hitch Pin w/Lock & Wrench, 5/8" for 2" Sq. Receivers (25 pack)
63146	Silent Hitch Pin w/Handle & Clip, 5/8" for 2" Sq. Receivers
63145-025	Silent Hitch Pin w/Clip, 5/8" for 2" Sq. Receivers (25 pack)



ADJUSTABLE CARGO CARRIERS



6501
(Shown with optional rail kit 6955 and optional cargo net 7330)

- Up to 500 lbs. capacity
- Adjustable fore & aft for best fit
- Mesh floor for easy cleanup
- Standard 3" side rails to retain cargo
- Attachment holes for load securing devices
- Angled design for maximum ground clearance
- Corner markers included for visibility (not pictured)
- Black powder coat finish resists corrosion
- Optional light kit available (#6504)



Part No.	Description	Mount	Class
6500	Hitch Mounted Cargo Carrier, 48" x 20" (Inside Dimensions) Platform, 300 lbs. Capacity	1-1/4" Receiver	I/II
6501	Hitch Mounted Cargo Carrier, 60" x 20" (Inside Dimensions) Platform, 500 lbs. Capacity	2" Receiver	III/IV



6504

63232



6505



1039700

Accessory / Replacement Parts

Part No.	Description
6955	Cargo Rail Kit - Telescoping Design Fits 6500 & 6501 - 12" Height
6550	Replacement Hardware for 6500 & 6501
6504	Light Kit for Cargo Carrier, contains Lights, 4-Flat Wiring Harness and License Plate Bracket
6505	Bike Rack Adapter for 6500, 6501 Cargo Carrier
1039700	Cargo Bag
63232	Silent Hitch Pin w/Lock & Wrench, 5/8" for 2" Sq. Receivers
63232-025	Silent Hitch Pin w/Lock & Wrench, 5/8" for 2" Sq. Receivers (25 pack)
63146	Silent Hitch Pin w/Handle & Clip, 5/8" for 2" Sq. Receivers
63145-025	Silent Hitch Pin w/Clip, 5/8" for 2" Sq. Receivers (25 pack)

FOLDING CARGO CARRIER



6502

- Tilts up for easy installation & storage
- 48" x 20" (inside dimensions) cargo platform
- 500 lbs. capacity
- Black powder coat finish resists corrosion
- Optional light kit available (#6504)

Part No.	Description	Mount	Class
6502	Folding Hitch Mounted Cargo Carrier 48" x 20" (inside dimensions) Platform	2" Receiver	III/IV

Accessory / Replacement Parts



6504

63232

1039700

Part No.	Description
6555	Replacement Hardware for 6502
6504	Light Kit for Cargo Carrier, contains Lights, 4-Flat Wiring Harness and License Plate Bracket
1039700	Cargo Bag
63232	Silent Hitch Pin w/Lock & Wrench, 5/8" for 2" Sq. Receivers
63232-025	Silent Hitch Pin w/Lock & Wrench, 5/8" for 2" Sq. Receivers (25 pack)
63146	Silent Hitch Pin w/Handle & Clip, 5/8" for 2" Sq. Receivers
63145-025	Silent Hitch Pin w/Clip, 5/8" for 2" Sq. Receivers (25 pack)



ATV / VEHICLE CARGO CARRIERS

- 1-1/4" square receiver tube openings
- Rated 50 lbs. for ATV's & 150 lbs. for vehicles

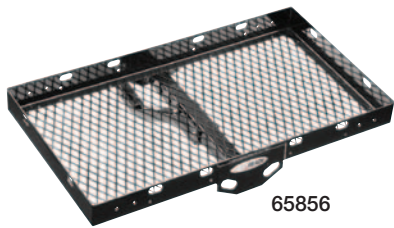

Part No.	Description
65855	ATV Cargo Carrier (36" x 20") w/1-1/4" shank
65852	ATV Cargo Carrier (36" x 20") w/2" shank

Accessory / Replacement Parts

Part No.	Description
65856	ATV Cargo Carrier Rail Kit - 12" high, fits #65852 & #65855
65857	Replacement Hardware for #65855 Cargo Carrier
65861	ATV Cargo Carrier Camo Bag (35" L x 19" W x 12" H)
65860	ATV Cargo Carrier Black Bag (35" L x 19" W x 12" H)

CARGO CARRIER ACCESSORIES

Part No.	Description
59100	Platypus® Expandable Roof Top Bag (10 to 15 cubic ft.)
59102	Walloo™ Expandable Cargo Bag (9-1/2 to 11-1/2 cubic ft.)
1039700	Cargo Bag, 20 cu. Ft. Rain Proof (59" x 24" x 24")
1041700	13 cu. ft. Rain Proof Cargo Bag (54" x 20" x 21")
65861	ATV Cargo Carrier Camo Bag (35" L x 19" W x 12" H)
65860	ATV Cargo Carrier Black Bag (35" L x 19" W x 12" H)
59200	Flat Strap Cargo Net - 36" x 48"
7330	Stretch Cargo Net for Cargo Carriers
59516	LED Light Kit for Cargo Carriers, 6" Oval Tail Lights and 4-Flat Wiring Harness
20174	Light Kit for Cargo Carriers, 6" Oval Tail Lights and 4-Flat Wiring Harness
6504	Light Kit for Cargo Carrier, Combination Lights, 4-Flat Wiring Harness and License Plate Bracket
6955	Cargo Rail Kit - Telescoping Design Fits 6500 & 6501 - 12" Height
65856	ATV Cargo Carrier Rail Kit - 12" high, fits 65852 & 65855
59904	Stingray™ Bike Carrier Clip, Converts Cargo Carrier to Bike Carrier (order 1/bike) for 59550, 59502, 59507, 63152, 63153, 63154, and 63155
6505	Bike Rack Adapter for 6500, 6501 Cargo Carrier
63232	Silent Hitch Pin w/Lock & Wrench, 5/8" for 2" Sq. Receivers
63232-025	Silent Hitch Pin w/Lock & Wrench, 5/8" for 2" Sq. Receivers (25 pack)
63146	Silent Hitch Pin w/Handle & Clip, 5/8" for 2" Sq. Receivers
63145-025	Silent Hitch Pin w/Clip, 5/8" for 2" Sq. Receivers (25 pack)

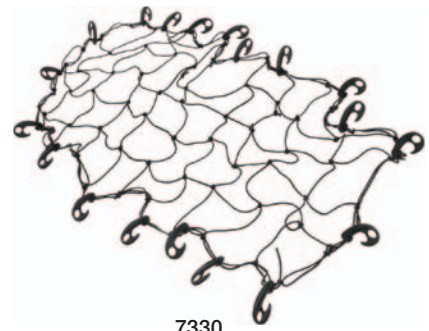
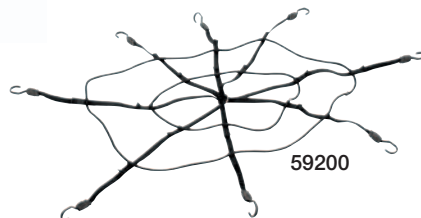
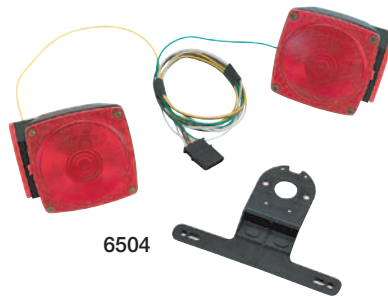



1040100

SOLO™ CARGO CARRIER AND RAMP ACCESSORY

Maximize your interior carrying capacity by transporting wet & messy items on our steel carriers. Mesh bottoms clean up quickly & easily!

- Built for oversized cargo
- 400 pounds (181 kg.) weight capacity
- Carries most scooters, movers and snow blowers
- Easy ten minute assembly
- Fits 2" square receivers (Class III / IV)
- Ramp Accessory (#1040200)
 - NO MORE LIFTING!
 - Lower ramp to wheel cargo onto basket
 - Bi-fold ramps stows for travel
- Optional light kit available (#6504)



1040200 (Ramp Accessory)

Part No.	Description	Mount	Class
1040100	Solo™ Hitch Mounted Utility Carrier, 48" x 32" x 3", 400 lbs. Capacity	2" Receiver	III/IV
1040200*	Utility Carrier Accessory Ramp, 44" x 30", 400 lbs. Capacity		

* Fits only #1040100 Solo™ Hitch Mounted Utility Carrier.



6504

Accessory / Replacement Parts

Part No.	Description
6504	Light Kit for Cargo Carrier, contains Lights, 4-Flat Wiring Harness and License Plate Bracket



5801600

TRANSPORTER™ SYSTEM

The Transporter™ Hitch Rack System is designed to transport heavy wheeled products, including mobility scooters and wheelchairs, mowers, snow blowers, generators, and other powered equipment.

- Large capacity with "Box Truss" design for lightweight and strength
- Ramp locks in vertical position for transportation
- Capacity of 48" x 32" x 7" (inside dimensions)
- Designed for wheelchair, scooters, generators, lawnmowers & snow blowers
- Silent Hitch Pin included for rattle free performance
- 300 lbs. weight capacity



Part No.	Description	Mount	Class
5801600	Transporter™ System w/7" Side Rails, 48" x 32" Platform, 2" Sq. Receiver Mount (Includes Ramp, Anti-Skid Tape, (4) D-Rings & Silent Hitch Pin)	2" Receiver	III/IV

Accessory / Replacement Parts

Part No.	Description
58394	Replacement Part, Hardware for 5800200, 5801600, 5802100
58395	Replacement Part, Hardware for 5800300, 5801600



GEARCAGE™ SP CARGO CARRIER

The GearCage™ SP hitch rack is a large capacity hitch mount cargo rack with a “Box Truss” design for light weight and high strength. The fixed platform design accommodates scooters, snowblowers, generators, and other gear that requires ample width and high rails to transport equipment.



5800200

- Large capacity with “Box Truss” design for light weight and strength
- Capacity of 48" x 32" x 7" (inside dimensions)
- Designed for wheelchair, scooters, generators, lawnmowers & snow blowers
- Silent Hitch Pin included for rattle free performance
- 300 lbs. weight capacity
- Ability to mount additional accessories onto basket



5800300



5800600

Part No.	Description	Mount	Class
5800200	GearCage™ SP (Straight Pipe) Cargo Carrier w/7" Side Rails, 48" x 32" Platform, 2" Sq. Receiver Mount (Includes Silent Hitch Pin)	2" Receiver	III/IV

Accessory / Replacement Parts

Part No.	Description
5800300	GearCage™ Cargo Carrier Accessory, Ramp 43" x 30" x 1"
58395	Replacement Part, Hardware for 5800300, 5801600
5800600	GearCage™ Cargo Carrier Accessory, Anti-Skid Tape 12'
5800700	Replacement Part, D-Rings for GearCage™ Cargo Carrier & The Moover™ Transporter System (4 pack)
5802100	Replacement Part, GearCage™ Cargo Carrier w/7" Side Rails, 32" x 48" Platform Only
58394	Replacement Part, Hardware for 5800200, 5801600, 5802100

CARGO BAGS FOR YOUR VEHICLE

POSITIONING

- Car top models
- Models to fit hitch mounted cargo carriers

POSITIONING

FEATURES

- Water resistant models, reduces dust and dirt infiltration
- Rainproof models, sonically welded seams with zipper rain flaps to greatly reduce water penetration
- Expandable styling
- Tie downs included

FEATURES

STORE YOUR VALUABLE CARGO!



59102



ROLA® WALLAROO™ EXPANDABLE CARGO BAG



- Expands from 9.5 to 11.5 cubic feet
- Constructed from premium quality rainproof material with sonically sealed seams
- Six straps for added attachment security
- Two interior pockets allow organization of smaller objects
- Zip closure allows the bag to expand just like your expandable luggage
- Fits cargo carriers up to 60" x 24"
- 48" x 19" x 18" expands to 48" x 19" x 22"

Part No.	Description
59102	Wallaroo™ Expandable Cargo Bag

Replacement Parts

Part No.	Description
59560	Replacement Part, Strap Kit (6)



59100



ROLA® PLATYPUS® EXPANDABLE CAR TOP BAG

- Weather resistant, expandable roof top storage bag (not waterproof)
- Sporty looking style and color
- Unique cinching system keeps cargo secure
- Expands from 10 to 15 cubic feet
- 41" x 35" x 20" expands to 41" x 35" x 24"

Part No.	Description
59100	Platypus® Expandable Car Top Bag



1039800

EXPANDABLE ROOF TOP CARGO BAG



- The backpack for your vehicle
- Storage and style in one car top carrier
- Easily attaches to all roof racks
- Expands from 10 cu. Ft. to 15 Cu. Ft.
- Folds flat and easy to store
- Weather resistant

Part No.	Description
1039800	10 - 15 Cu. Ft. Expandable Car Top Bag, 37" x 32" x 19"-21"



1038800

CAR TOP CARRIERS



- Double your storage area and free up space in your vehicle
- Rainproof bags made with quality waterproof material and sonic welding technology
- All installation hardware included

Part No.	Description
1038800	Weather Resistant Car Top Bag w/Storage Sack - 38" x 38" x 18" (10 cubic ft.), Black
1038900	Rainproof Car Top Bag w/Storage Sack - 37" x 30" x 16" (15 cubic ft.), Black



1038900



1039700

CARGO BAGS



- Perfect to store luggage, camping equipment, etc.
- Rainproof construction offers wonderful protection against the weather
- Zip closure, Folds up for easy, compact storage
- Fits cargo carriers up to 60" x 24"

Part No.	Description
1041700	13 cu. ft. Rain Proof Cargo Bag (54" x 20" x 21")
1039700	20 cu. ft. Rain Proof Cargo Bag (59" x 24" x 24")



65860



65861

ATV CARGO CARRIER BAGS



Part No.	Description
65861	ATV Cargo Carrier Camo Bag (35"L x 19"W x 12"H)
65860	ATV Cargo Carrier Black Bag (35"L x 19"W x 12"H)

ORGANIZE & PROTECT YOUR VEHICLE

ORGANIZE

Vehicle Interior

- Cargo organizers
- Cargo and clothes hanger bars
- Storage nets
- Pet barrier

Vehicle Exterior

- Tailgate nets
- Cargo nets
- Truck bed nets
- Storage nets
- Spare tire covers

ORGANIZE

PROTECTION

Spare Tire Cover

- Improve your vehicle appearance
- Protect your exposed spare tire

Car / Motorcycle Cover

- Ideal covers for storage
- Protects from scratches, dust, dirt and weather

Interior Cargo Guard

- Fits SUV interior cargo area
- Protects when hauling hay, plants, dirt and more

PROTECTION

SMART STORAGE SOLUTIONS!



9500900
9501400

SPARE TIRE COVERS



- Improve the look of your vehicle
- Protect your spare tire
- Two sizes fit all spare tires

Part No.	Description
9500900	Spare Tire Cover 27" to 29"
9501400	Spare Tire Cover 30" to 32"



9480000



9480100

CAR AND MOTORCYCLE COVERS

- Ideal covers for vehicle or motorcycle storage
- Protects vehicles or motorcycles from scratches, dust, dirt and weather
- Elastic bottom creates a custom fit
- Storage bag included

Part No.	Description
9480000	Motorcycle Cover w/Storage Bag, Nylon Shell w/Non-woven Liner, Fits Touring Cycles Up To 1500 cc
9480100	Essential Car Cover w/Storage Bag, Non-woven Polyethylene, Fits Full Size Cars 191" To 210"



1043500

INTERIOR CARGO GUARD™

- Protects the entire cargo area floors, walls and ceiling from dirt and debris
- One size fits all SUVs, hook and loop straps attach over the vehicle
- Clear vinyl window visibility

Part No.	Description
1043500	Interior Cargo Guard™ - 51" x 44" x 28" (38 Cu. Ft.)



59000



ROLA® M.O.V.E.™ (MOBILE ORGANIZATIONAL VEHICLE EQUIPMENT)

- Rigid base with exclusive non-slip bottom
- Instant organization for trunks or rear cargo space of any size
- The perfect solution for keeping groceries, sports gear, tools, office files and safety items in one place
- Moveable interior dividers customize the storage area for any size or shape of cargo
- Exclusive, spring loaded, self-opening system
- Folds flat for convenient storage when not in use



Part No.	Description
59000	Rigid Base Organizer (small) 25" x 15" x 7"
59001	Rigid Base Organizer (large) 38" x 15" x 7"



1982200

TRUCK CAB ORGANIZERS



- Durable fabric with twelve pockets
- Designed to fit standard pickup trucks
- Fits behind front seat

Part No.	Description
1982200	Turbo Truck Cab Interior Organizer
9502600	Turbo Trunk Small Interior Organizer



9142200

CLOTHES HANGER BAR



- Fits all cars, vans and SUVs
- Three retainer rings prevent sliding
- Bar hangs from clothes hooks or hooks onto grab handles
- Adjusts from 36" to 65"

Part No.	Description
9142200	Adjustable Cargo Bar w/Storage Net 40" to 74"



1970000

CARGO BARS



- Stop cargo from shifting in all SUVs, trucks and vans
- Easy installation and universal fit
- Unique rubber pads hold securely with no risk of scratching your vehicle
- Two styles to choose from:
 - Cargo bar installs easily and adjusts with a twist
 - The ratcheting style cargo bar allows for the precise tensioning needed to secure heavy loads

Part No.	Description
1970000	Bar, 40" – 74"
1970200	Ratcheting Cargo Bar, 40" – 70"



2004500

UNIVERSAL PET BARRIER

- Pet Barrier gently keeps your pet in the cargo area of your vehicle
- Sleek, modern styling does not look "cagey"
- Made with heavy gauge tubing, the Pet Barrier fits all mini-vans and SUVs
- Installs in minutes

Part No.	Description
2004500	Universal Pet Barrier



59200

ROLA® FLAT STRAP CARGO NET

- Wide, flat strap bungee cargo net is designed to hold gear more securely and without damage to sensitive or fragile cargo
- Ideal for roof racks and cargo carriers
- Size 48" x 36"
- Wide hook openings fit a variety of racks
- Added loops allow net to fit on any rack or carrier



Part No.	Description
59200	Flat Strap Cargo Net

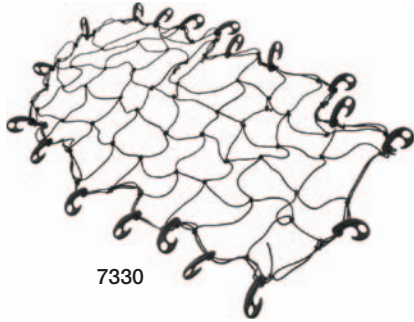

7330

STRETCH CARGO NET

Part No.	Description
7330	Stretch Net Cargo Net for Cargo Carriers & Roof Rack



9500700
9500800

TAILGATE NETS



- Won't fade, crack or scratch
- More rear visibility
- Easy to Install
- 2 sizes for mid-size or full-size trucks

Part No.	Description
9500700	Tailgate Net - Fits Mini/Mid-Size Pickups - 52" x 16"
9500800	Tailgate Net - Fits Full Size Pickups - 56" x 18 1/2"



9501500

TURBO NET



- Self-supporting tailgate nets will not sag or tear even under the toughest conditions
- Made of galvanized steel tubing and heavy-duty vinyl coated polyester
- Telescoping poles feature an easy-on, easy-off pin system that does not require screw or fasteners

Part No.	Description
9501500	Turbo Net, Full Size Truck - 60-1/4" To 65" Wide x 19" Tall



9502200

V-NET



- Self-supporting tailgate nets will not sag or tear even under the toughest conditions
- Made of galvanized steel tubing and heavy-duty vinyl coated polyester
- Telescoping poles feature an easy-on, easy-off pin system that does not require screw or fasteners

Part No.	Description
9502200	V-Net 2000, Newer Fifth Wheel Trucks, 62" to 64-1/2" Wide x 19" Tall

9500600



UNIVERSAL HEAVY DUTY TRUCK NET



- Safely secures cargo inside back of pickup truck
- Easy to install, holds up under extreme weather conditions
- Adjustable for all trucks

Part No.	Description
9500600	Adjustable Heavy Duty Truck Cargo Net, Universal

9500500



TRUCK BED CARGO NETS

- Safely secures cargo inside back of pickup truck
- Easy to install, holds up under extreme weather conditions
- Adjustable for all trucks

Part No.	Description
9500500	60" x 78" Deluxe Bungee Truck Net
9500100	36" x 48" Net for Roofs and Cargo Racks



9501000

STORAGE NETS

- Organize and secure cargo in your car, truck, SUV or van
- Interior nets install easily with 3M tape or OE style screws (both included)
- Cargo net secures gear to automotive roof racks or rear cargo carriers

Part No.	Description
9501000	Bulkhead/Trunk Storage Net 48" to 60" x 12", Black
9501200	Hammock Storage Net - 45" to 60" x 12", Black



9501200



9501300

STORAGE NET

- Organize and secure cargo in your car, truck, SUV or van
- Interior nets install easily with 3M tape or OE style screws (both included)
- Cargo net secures gear to automotive roof racks or rear cargo carriers

Part No.	Description
9501300	3 Pocket Storage Net - 48" to 60" x 13", Black



9142000

CARGO BAR WITH NET

- Great for securing and organizing cargo
- Designed for easy installation and universal fit
- Rubber end pads hold securely, won't scratch your vehicle

Part No.	Description
9142000	Adjustable Cargo Bar w/Storage Net 40" to 74"

SECURING YOUR CARGO

SECURING

SECURING

Tie Downs

- Titan/Titan Max ratchets
- Automotive ratchets
- Marine transom/gunwale ratchets
- Automotive cambuckles
- Marine bow/transom cambuckles
- Trailer tie downs

Bungee Cords

- Fat strap bungee cords
- Triple strength cords
- Heavy duty bungee cords

Straps

- Lashing straps
- Tarp straps
- Tow ropes & straps

TIE DOWNS / CORDS / STRAPS FOR ALL YOUR NEEDS!



1157200



1157100



1157300



1158400

TITAN RATCHET TIE DOWNS

- Ratchet tie downs provide super strong holding power & precise tension adjustment
- Stylish Cast Handle Steel handle with padded grip
- Easy to reach release button

HIGHLAND



Part No.	Description	Duty Rating	Load Capacity (lbs)	Break Strength (lbs)	Color	Packaging
1157200	Titan Ratchet Tie Down, 1" x 6'	Std	600	1800	Black	Open (2-pack)
1157300	Titan Ratchet Tie Down, 1" x 10'	Std	600	1800	Black	Open (4-pack)
1157100	Titan Ratchet Tie Down, 1" x 14'	Std	600	1800	Black	Open (Single)

TITAN MAX GRIP RATCHET TIE DOWNS

- Full open grip handle, fits any sized hand comfortably
- Cast aluminum handled ratchets
- Curved release button for ease of use



Part No.	Description	Duty Rating	Load Capacity (lbs)	Break Strength (lbs)	Color	Packaging
1158300	Titan Max Grip Ratchet Tie Down, 1" x 14'	Heavy	1000	3000	Black	Open (Single)
1158400	Titan Max Grip Ratchet Tie Down, 1" x 14'	Heavy	1000	3000	Black	Open (2-pack)
1158500	Titan Max Grip Ratchet Tie Down, 1" x 14'	Heavy	1000	3000	Black	Open (4-pack)



2060666



2060066

MARINE CAMBUCKLE TIE DOWNS

Bow Cambuckles

- Vinyl coated S-hooks protect boats finish
- Provides super strong holding power
- Some models available with stainless steel housing



Transom Cambuckles

- Locks in place to eliminate slippage
- Protective housing prevents scratches
- Some models available with stainless steel housing



Part No.	Description	Duty Rating	Load Capacity (lbs)	Break Strength (lbs)	Color	Packaging
2060166	Cambuckle Tie Down w/Hooks - (Bow) 1" x 36", Stainless Steel	Light	300	900	Black	Clam Shell (2-pack)
2060066	Cambuckle Tie Down w/Hooks - (Bow) 1" x 36", Zinc	Standard	400	1200	Black	Clam Shell (2-pack)
2060566	Surelok Cambuckle Tie Down - (Transom) 2" x 24", Stainless Steel	Light	333	1000	Black	Open (2-pack)
2061966	Surelok Cambuckle Tie Down - (Transom) 2" x 48", Stainless Steel	Light	333	1000	Black	Bulk
2060666	Surelok Cambuckle Tie Down - (Transom) 2" x 48", Stainless Steel	Light	333	1000	Black	Open (2-pack)
2060466	Surelok Cambuckle Tie Down - (Transom) 2" x 24", Zinc	Heavy Duty	833	2500	Black	Open (2-pack)
2060766	Surelok Cambuckle Tie Down - (Transom) 2" x 48", Zinc	Heavy Duty	833	2500	Black	Poly Bag (Single)



2060266



2061566

MARINE RATCHET TIE DOWNS

Retractable Transom Ratchets

- Strap retracts for easy storage and no tangling
- Easy bolt on function (Hardware included)
- Some models available with stainless steel housing



Gunwale Ratchets

- Vinyl coated J-hooks protect boats finish
- Provides super strong holding power
- Some models available with stainless steel housing



Part No.	Description	Duty Rating	Load Capacity (lbs)	Break Strength (lbs)	Color	Packaging
2061866	Retractable Tie Down - (Transom) 2" x 43", Stainless Steel	Standard	600	1800	Black	Bulk
2060266	Retractable Tie Down - (Transom) 2" x 43", Stainless Steel	Standard	600	1800	Black	Open (2-pack)
2061766	Retractable Tie Down - (Transom) 2" x 43", Zinc	Heavy Duty	833	2500	Black	Bulk
2060366	Retractable Tie Down - (Transom) 2" x 43", Zinc	Heavy Duty	833	2500	Black	Open (2-pack)
2060866	Max Grip Ratchet - (Gunwale) 2" x 10', Stainless Steel	Light	333	1000	Black	Open (Single)
2060966	Max Grip Ratchet - (Gunwale) 2" x 13', Stainless Steel	Standard	400	1200	Black	Open (Single)
2061066	Max Grip Ratchet - (Gunwale) 2" x 16', Stainless Steel	Standard	400	1200	Black	Open (Single)
2061166	Max Grip Ratchet - (Gunwale) 2" x 20', Stainless Steel	Standard	400	1200	Black	Open (Single)
2061266	Max Grip Ratchet - (Gunwale) 2" x 10', Zinc	Heavy Duty	833	2500	Black	Open (Single)
2061366	Max Grip Ratchet - (Gunwale) 2" x 13', Zinc	Heavy Duty	833	2500	Black	Open (Single)
2061466	Max Grip Ratchet - (Gunwale) 2" x 16', Zinc	Heavy Duty	833	2500	Black	Open (Single)
2061566	Max Grip Ratchet - (Gunwale) 2" x 20', Zinc	Heavy Duty	833	2500	Black	Open (Single)



1152101



1170000



1160400



1153500



1154000



1154201

AUTOMOTIVE TIE DOWNS

Part No.	Description	Duty Rating	Load Capacity (lbs)	Break Strength (lbs)	Color	Packaging
RATCHET TIE DOWNS						
1152101	Ratchet Tie Down w/Padded Handle - 1" x 6'	Std	600	1800	Orange	Open (2-pack)
1153500	Retractable Ratchet Tie Down - 1" x 6'	Std	400	1200	Camo	Open (2-pack)
1151801	Retractable Ratchet Tie Down - 1" x 6' (motorcycle)	Std	500	1500	Black	Open (2-pack)
1154000	Retractable Ratchet Tie Down - 2" x 10', 1100 lbs.	Heavy	1100	3300	Black	Bulk (Single)
1169900	Ratchet Tie Down (endless) - 1" x 12'	Light	300	900	Red	Open (Single)
1170000	Ratchet Tie Down w/Hooks - 1" x 13'	Light	300	900	Red	Clam Shell (Single)
1227000	Ratchet Tie Down - 1" x 10'	Light	300	900	Red	Open (Single)
9210500	Ratchet Tie Down - 1" x 10'	Light	300	900	Red	Open (4-pack)
1152301	Ratchet Tie Down w/Hooks - 1" x 6'	Std	500	1500	Camo	Open (2-pack)
1170200	Ratchet Tie Down - 1" x 6'	Std	500	1500	Blue	Clam Shell (2-pack)
1170500	Ratchet Tie Down - 1" x 14'	Std	500	1500	Blue	Clam Shell (Single)
9010500	Ratchet Tie Down - 1" x 10'	Std	500	1500	Red	Open (4-pack)
1151601	Ratchet Tie Down w/Hooks- 1-1/4" x 10'	Heavy	1100	3300	Yellow	Open (2-pack)
1160400	Ratchet Tie Down w/Reflective Webbing (ATV) - 1" x 12'	Heavy	1100	3300	Black	Open (4-pack)
1151701	Ratchet Tie Down w/Hooks- 1-1/2" x 15'	Super	1830	5500	Yellow	Open (Single)
1152500	HD Ratchet Tie Down w/Hooks - 2" x 25', 10,000 lbs. - Break Strength	Super	3330	10000	Yellow	Open (Single)
1272700	Ratchet Tie Down - 2" x 27'	Super	3330	10000	Yellow	Clam Shell (Single)
CAMBUCKLE TIE DOWNS						
9231300	Lashing Strap w/Spring - 12'	Lashing	n/a	100	Red	Clam Shell (2-pack)
9210600	Cambuckle Tie Down w/Hooks - 1" x 6'	Light	300	900	Blue	Open (4-pack)
1033300	Cambuckle Tie Down w/Hooks - 1" x 10'	Light	300	900	Red	Clam Shell (Single)
1034200	Cambuckle Tie Down w/Hooks - 1" x 6'	Std	400	1200	Black	Clam Shell (2-pack)
1152401	Cambuckle Tie Down w/Hooks - 1" x 6'	Std	400	1200	Camo	Open (2-pack)
1154201	Cambuckle Tie Down w/Hooks - 1" x 6'	Std	430	1300	Orange	Open (2-pack)
1034400	Cambuckle Tie Down w/Hooks - 1" x 12'	Std	400	1200	Black	Clam Shell (Single)
9180200	Cambuckle Tie Down w/Hooks - 1" x 6'	Std	400	1200	Red	Open (4-pack)
1150601	Cambuckle Tie Down w/Hooks - 2" x 6'	Heavy	830	2500	Yellow	Open (2-pack)
1152201	SureLok Cambuckle Tie Down w/Hooks - 1" x 6'	Std	500	1500	Black	Open (2-pack)
1156201	SureLok Cambuckle Tie Down w/Hooks - 1.75" x 6'	Heavy	1000	3000	Black	Open (2-pack)



FAT STRAP BUNGEE CORDS

- Won't damage or dig into your cargo
- Extra wide, strong and secure
- Coated steel hooks are stronger than conventional hooks
- Rotating Fat Straps rotate 360 degrees for easy adjustment
- Reflective Fat Straps increase visibility for all drivers

Part No.	Description
9412000	20" Fat Strap Bungee
9413000	30" Fat Strap Bungee
9414500	45" Fat Strap Bungee
9414900	10" - 45" Adjustable Fat Strap Bungee
9002900	6 pc. Fat Strap Assortment: 2 - 15", 2 - 20", 2 - 30", Jar Pack
9002600	18 pc. Fat Strap Assortment: 3 - 15", 2 - 18", 2 - 20", 2 - 24", 2 - 30", 2 - 32", 1 - O-Ring, 4 mini, Jar Pack



TRIPLE STRENGTH BUNGEE CORDS

- Coated steel hooks are 3X stronger than conventional hooks
- Won't bend, break, scratch or mar
- Color coded hooks for convenient selection
- Engineered to withstand even the harshest outdoor elements

Part No.	Description
9302400	24" Triple Strength
9303200	32" Triple Strength
9304000	40" Triple Strength
9305200	52" Triple Strength



BUNGEE CORDS

Heavy Duty Bungee Cords feature molded hooks to prevent rust and corrosion; coated steel hooks have extra wide openings to improve fit and performance. Color coded by cord size.

Part No.	Description
9201800	2 pc. Bungee Cords: 2 - 18" x 8mm
9232400	2 pc. Bungee Cords: 2 - 24" x 8mm
9402400	1 pc. Bungee Cord - 24"
9203200	2 pc. Bungee Cords: 2 - 32" x 8mm
9009500	6 pc. Heavy Duty Bungee Cord Assortment: 2 -18" x 8mm, 1 - 24" x 8mm, 1 - 32" x 9mm, 2 Mini
9009600	8 pc. Heavy Duty Bungee Cord Assortment: 2 - 12" x 8mm, 2 - 18" x 8mm, 1 - 24" x 8mm, 1 - 32" x 9mm, 2 mini
9008600	12 pc. Heavy Duty Bungee Cord Assortment: 3 Mini, 3 - 18" x 8mm, 2 - 24" x 8mm, 1 - 32" x 9mm, 1 - 40" x 10mm, 2 Canopy Ties, Jar Pack
9002200	20 pc. Bungee Cord Assortment (6 - 18", 4 - 24", 2 - 32", 2 - 40", 6 - 10")
9008400	24 pc. Heavy Duty Bungee Cord Assortment: 6 Mini, 6 - 18" x 8mm, - 24" x 8mm, 2 - 32" x 9mm, 2 - 40" x 10mm, 4 Canopy Ties, Jar Pack
9052000	20 pc. Mini Bungee Cords: 20 - 10" x 8mm





59204

ROLA® LIGHT DUTY LASHING STRAP

- Lashing strap design for luggage or light duty carrying & securing needs

Part No.	Description	Duty Rating	Load Capacity (lbs)	Break Strength (lbs)	Color	Packaging
59204	Lashing Strap - 1" x 10'	Lashing	55	165	Black	Clam Shell (2-pack)



9133900

TARP STRAPS

Tarp Straps are engineered to outperform the competition in cut, tear and strength tests. UV-resistant EDPM rubber maintains strength and performance in all weather conditions.

Part No.	Description
9133900	6 pc. Tarp Strap Assortment: 2 - 15", 2 - 21", 2 - 31", Jar Pack



1270700

1275000
1275500

TRAILERING TIE DOWNS

- Safely secures many kinds of vehicles to trailers for transportation
- Constructed with heavy duty non-slip ratchets and weather resistant Power Web Plus™ webbing
- Engineered for maximum tension and easy release
- Heavy duty axle strap with high tensile steel rings allows easy, secure trailering of vehicle, using vehicle axle
- #1275000 and #1275500 employ over-the-wheel tie down design to secure vehicles to trailer

Part No.	Description
1270700	1-1/2" x 7' Ratchet Tie Down, 6,000 lbs. Break Strength, 2,000 lbs. Load Capacity
1275000	9" Tire Width, 6,000 lbs. Break Strength, 2,000 lbs. Load Capacity
1275500	25" Tire Width, 6,000 lbs. Break Strength, 2,000 lbs. Load Capacity

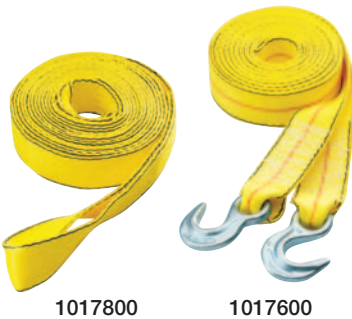

1017800

1017600

TOW ROPES AND STRAPS

- High quality polypropylene braided rope with corrosion resistant zinc plated hooks
- Tow Ropes also include a protective sleeve to help protect the products from cuts and abrasions
- Tow Straps are made of heavy duty, 10,000 lbs. capacity Power Web™ webbing with zinc plated forged hooks

Part No.	Description
1017600	2" x 20' Tow Strap w/Hooks, 10,000 lbs. Break Strength
1017800	2" x 20' Tow Strap w/Loop Ends, 17,000 lbs. Break Strength

* 5,000 lbs. break strength - Use for loads up to 1,600 lbs.

RAMPS FOR YOUR VEHICLE

LOADING

Features

- Aluminum/steel construction
- Straight/bi-/tri-/center-fold design
- Straight/arched styling
- Rust and corrosion resistant

Good For

- Easily load ATVs

LOADING

LOAD WITH EASE!



1120500

STRAIGHT ALUMINUM LOADING RAMP **HIGHLAND**

- Welded aluminum construction
- Rust and corrosion resistant
- Adjustable attachment strap
- Sold as pair

Part No.	Description
1120500	69" Straight Aluminum Loading Ramp, 1,250 lbs. Capacity (625 lbs. per Ramp)



1123000

STRAIGHT STEEL LOADING RAMP

- One piece steel construction
- Rust and corrosion resistant

Part No.	Description
1123000	69" Straight Steel Loading Ramp, 600 lbs. Capacity



1123100

ARCHED ALUMINUM LOADING RAMP

- Center-fold for easy storage
- Arched for easier loading
- Welded aluminum construction
- Rust and corrosion resistant
- Adjustable attachment strap
- Sold as pair

Part No.	Description
1123100	Arched Aluminum Center-Fold Loading Ramp, 1,500 lbs. Capacity (750 lbs. per Ramp)



1120800

SPORTMAX UTILITY RAMP

- Lightweight aluminum construction
- Rust and corrosion resistant

Part No.	Description
1120800	69" length x 15" width Bi-Fold Utility Ramp, Pair, 1,400 lbs. Capacity (700 lbs. per Ramp)



1122600

TRI-FOLD UTILITY RAMPS

- Lightweight aluminum construction
- Rust and corrosion resistant
- Item Qty: Single

Part No.	Description
1121400	69" length x 45" width Tri-Fold Utility Ramp, 1,500 lbs. Capacity
1121500	77" length x 54" width Tri-Fold Utility Ramp, 1,500 lbs. Capacity
1122600	69" length x 45" width Tri-Fold Loading Ramp, 1,400 lbs. Capacity

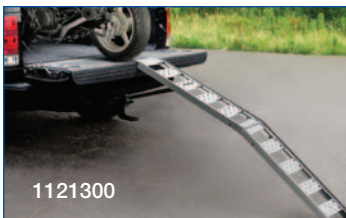

1121300

CENTER FOLDING LOADING RAMP

- Lightweight aluminum construction
- Item Qty: Single

Part No.	Description
1121300	85" length x 12" width Center Fold Loading Ramp, 700 lbs. Capacity

ROOF RACK APPLICATION GUIDE

MAKE	MODEL	STYLE	YEAR	PART NO.	FN	INSTALL TIME	RACK DESIGN	MOUNTING SYSTEM	BAR QTY	WEIGHT CAPACITY
Acura	MDX	w/Factory Roof Rails	07-11	59711	Ø,LC	15	Sports	RBU	2	165 lbs.
Acura	MDX	w/Factory Roof Rails		59899	Ø	15	Sports	RBU	2	165 lbs.
Acura	RDX	w/Factory Roof Rails	2011	59899	Ø	15	Sports	RBU	2	165 lbs.
Acura	TSX Sport Wagen	w/Factory Roof Rails	2011	59898	Ø	15	Sports	RBU	2	165 lbs.
Audi	A4 Avant	Wagon w/Factory Roof Rails	98-01	59898	Ø	15	Sports	RBU	2	165 lbs.
Audi	A4 Avant	Wagon w/Factory Roof Rails	02-04	59897	Ø	15	Sports	RBU	2	165 lbs.
Audi	A4 Avant	Wagon w/Factory Roof Rails		59898	Ø,LA	15	Sports	RBU	2	165 lbs.
Audi	A4 Avant	Wagon w/Factory Roof Rails	05-08	59898	Ø	15	Sports	RBU	2	165 lbs.
BMW	323i	Sports Wagon w/Factory Roof Rails	2000	59898	Ø	15	Sports	RBU	2	165 lbs.
BMW	325i	Sports Wagon w/Factory Roof Rails	01-05	59898	Ø	15	Sports	RBU	2	165 lbs.
BMW	325xi	Sports Wagon w/Factory Roof Rails	01-05	59898	Ø	15	Sports	RBU	2	165 lbs.
BMW	328i	Sports Wagon w/Factory Roof Rails	06-10	59898	Ø	15	Sports	RBU	2	165 lbs.
BMW	328xi	Sports Wagon w/Factory Roof Rails	06-10	59898	Ø	15	Sports	RBU	2	165 lbs.
BMW	525i	Sports Wagon w/Factory Roof Rails	01-03	59898	Ø	15	Sports	RBU	2	165 lbs.
BMW	528i	Sports Wagon w/Factory Roof Rails	2000	59898	Ø	15	Sports	RBU	2	165 lbs.
BMW	528iT	Sports Wagon w/Factory Roof Rails	1999	59898	Ø	15	Sports	RBU	2	165 lbs.
BMW	530xi	Sports Wagon w/Factory Roof Rails	06-07	59898	Ø	15	Sports	RBU	2	165 lbs.
BMW	535xi	Sports Wagon w/Factory Roof Rails	08-09	59898	Ø	15	Sports	RBU	2	165 lbs.
BMW	540i	Sports Wagon w/Factory Roof Rails	99-03	59898	Ø	15	Sports	RBU	2	165 lbs.
BMW	X3	w/Factory Roof Rails	04-10	59827	Ø	15	Sports	RB	2	110 lbs.
BMW	X3	w/Factory Roof Rails		59899	Ø	15	Sports	RBU	2	165 lbs.
BMW	X5	w/Factory Roof Rails	00-06	59828	Ø	15	Sports	RB	2	110 lbs.
BMW	X5	w/Factory Roof Rails		59899	Ø	15	Sports	RBU	2	165 lbs.
BMW	X5	w/Factory Roof Rails	07-10	59829	Ø	15	Sports	RB	2	110 lbs.
BMW	X5	w/Factory Roof Rails		59899	Ø	15	Sports	RBU	2	165 lbs.
Buick	Rainier	w/Factory Roof Rails	06-07	59898	Ø	15	Sports	RBU	2	165 lbs.
Cadillac	SRX	w/Factory Roof Rails	04-09	59898	Ø	15	Sports	RBU	2	165 lbs.
Cadillac	SRX	w/Factory Roof Rails		59899	Ø,LB	15	Sports	RBU	2	165 lbs.
Cadillac	SRX	w/Factory Roof Rails	10-12	59893	Ø	5	Sports	RBXL	2	165 lbs.
Cadillac	SRX	w/Factory Roof Rails		59898	Ø	15	Sports	RBU	2	165 lbs.
Cadillac	SRX	w/Factory Roof Rails		59899	Ø,LB	15	Sports	RBU	2	165 lbs.
Chevrolet	Avalanche	w/Factory Roof Rails	07-11	59711	Ø,LC	15	Sports	RBU	2	165 lbs.
Chevrolet	Avalanche	w/Factory Roof Rails		59899	Ø	15	Sports	RBU	2	165 lbs.
Chevrolet	Blazer	Downsize, All Models w/Factory Roof Rails	95-97	59898	Ø	15	Sports	RBU	2	165 lbs.
Chevrolet	HHR	w/Factory Roof Rails	06-11	59897	Ø	15	Sports	RBU	2	165 lbs.
Chevrolet	HHR SS	w/Factory Roof Rails	08-10	59897	Ø	15	Sports	RBU	2	165 lbs.
Chevrolet	S-10 Blazer	Downsize, All Models w/Factory Roof Rails	03-04	59898	Ø	15	Sports	RBU	2	165 lbs.
Chevrolet	Suburban	Old Body Style w/Factory Roof Rails	92-99	59711	Ø,LC	15	Sports	RBU	2	165 lbs.
Chevrolet	Suburban	Old Body Style w/Factory Roof Rails		59899	Ø	15	Sports	RBU	2	165 lbs.
Chevrolet	Suburban	New Body Style w/Factory Roof Rails	00-11	59711	Ø,LC	15	Sports	RBU	2	165 lbs.
Chevrolet	Suburban	New Body Style w/Factory Roof Rails		59899	Ø	15	Sports	RBU	2	165 lbs.
Chevrolet	Tahoe	Old Body Style w/Factory Roof Rails	95-00	59711	Ø,LC	15	Sports	RBU	2	165 lbs.
Chevrolet	Tahoe	Old Body Style w/Factory Roof Rails		59899	Ø	15	Sports	RBU	2	165 lbs.
Chevrolet	Tahoe	New Body Style w/Factory Roof Rails	00-11	59711	Ø,LC	15	Sports	RBU	2	165 lbs.
Chevrolet	Tahoe	New Body Style w/Factory Roof Rails		59899	Ø	15	Sports	RBU	2	165 lbs.
Chevrolet	Tracker	w/Factory Roof Rails	98-04	59899	Ø	15	Sports	RBU	2	165 lbs.
Chevrolet	TrailBlazer	w/Factory Roof Rails	99-01	59898	Ø	15	Sports	RBU	2	165 lbs.
Chevrolet	Uplander	w/Factory Roof Rails	05-08	59899	Ø	15	Sports	RBU	2	165 lbs.
Chevrolet	Uplander	w/Factory Roof Rails (Canada Only)	2009	59899	Ø	15	Sports	RBU	2	165 lbs.

ROOF RACK APPLICATION GUIDE

MAKE	MODEL	STYLE	YEAR	PART NO.	FN	INSTALL TIME	RACK DESIGN	MOUNTING SYSTEM	BAR QTY	WEIGHT CAPACITY
Chevrolet	Venture	w/Factory Roof Rails	97-05	59898	Ø	15	Sports	RBU	2	165 lbs.
Chevrolet	Venture	w/Factory Roof Rails		59899	Ø,LB	15	Sports	RBU	2	165 lbs.
Chrysler	Aspen	w/Factory Roof Rails	07-09	59898	Ø	15	Sports	RBU	2	165 lbs.
Chrysler	Aspen	w/Factory Roof Rails		59899	Ø,LB	15	Sports	RBU	2	165 lbs.
Dodge	Durango	w/Factory Roof Rails	04-09	59898	Ø	15	Sports	RBU	2	165 lbs.
Dodge	Durango	w/Factory Roof Rails		59899	Ø,LB	15	Sports	RBU	2	165 lbs.
Dodge	Journey	w/Factory Roof Rails	09-11	59898	Ø	15	Sports	RBU	2	165 lbs.
Dodge	Journey	w/Factory Roof Rails		59899	Ø,LB	15	Sports	RBU	2	165 lbs.
Ford	Edge	w/Factory Roof Rails	07-11	59899	Ø	15	Sports	RBU	2	165 lbs.
Ford	Escape	w/Factory Roof Rails	08-11	59897	Ø	15	Sports	RBU	2	165 lbs.
Ford	Escape	w/Factory Roof Rails		59898	Ø,LA	15	Sports	RBU	2	165 lbs.
Ford	Explorer	2 Dr. Sport w/Factory Roof Rails	01-03	59899	Ø	15	Sports	RBU	2	165 lbs.
Ford	Explorer	4 Dr. w/Factory Roof Rails	02-05	59897	Ø	15	Sports	RBU	2	165 lbs.
Ford	Explorer	4 Dr. w/Factory Roof Rails		59898	Ø,LA	15	Sports	RBU	2	165 lbs.
Ford	Explorer	w/Factory Roof Rails	2011	59711	Ø	15	Sports	RBU	2	165 lbs.
Ford	Explorer Sport Trac	w/Factory Roof Rails	01-05	59899	Ø	15	Sports	RBU	2	165 lbs.
Ford	Freestar	w/Factory Roof Rails	04-07	59897	Ø	15	Sports	RBU	2	165 lbs.
Ford	Freestar	w/Factory Roof Rails		59898	Ø,LA	15	Sports	RBU	2	165 lbs.
Ford	Freestyle	w/Factory Roof Rails	05-07	59899	Ø	15	Sports	RBU	2	165 lbs.
GMC	Envoy	w/Factory Roof Rails	98-01	59898	Ø	15	Sports	RBU	2	165 lbs.
GMC	Jimmy	Downsize, All Models w/Factory Roof Rails	2002	59898	Ø	15	Sports	RBU	2	165 lbs.
GMC	Yukon	Old Body Style w/Factory Roof Rails	92-00	59711	Ø,LC	15	Sports	RBU	2	165 lbs.
GMC	Yukon	Old Body Style w/Factory Roof Rails		59899	Ø	15	Sports	RBU	2	165 lbs.
GMC	Yukon	New Body Style w/Amber Turn Signals	00-11	59711	Ø,LC	15	Sports	RBU	2	165 lbs.
GMC	Yukon	New Body Style w/Amber Turn Signals		59899	Ø	15	Sports	RBU	2	165 lbs.
GMC	Yukon XL	w/Factory Roof Rails	00-11	59711	Ø,LC	15	Sports	RBU	2	165 lbs.
GMC	Yukon XL	w/Factory Roof Rails		59899	Ø	15	Sports	RBU	2	165 lbs.
Honda	Accord	4 Dr. Sedan	03-07	59802	Ø	15	Sports	RM	2	88 lbs.
Honda	Odyssey	w/Factory Roof Rails	99-11	59898	Ø	15	Sports	RBU	2	165 lbs.
Honda	Odyssey	w/Factory Roof Rails		59899	Ø,LB	15	Sports	RBU	2	165 lbs.
Honda	Passport	w/Factory Roof Rails	98-02	59711	Ø,LC	15	Sports	RBU	2	165 lbs.
Honda	Passport	w/Factory Roof Rails		59899	Ø	15	Sports	RBU	2	165 lbs.
Honda	Pilot	w/Factory Roof Rails	03-08	59898	Ø	15	Sports	RBU	2	165 lbs.
Honda	Pilot	w/Factory Roof Rails		59899	Ø,LB	15	Sports	RBU	2	165 lbs.
Honda	Pilot	w/Factory Roof Rails	09-11	59711	Ø,LC	15	Sports	RBU	2	165 lbs.
Honda	Pilot	w/Factory Roof Rails		59899	Ø	15	Sports	RBU	2	165 lbs.
Hyundai	Accent	4 Dr. Sedan, w/o Factory Roof Rails	2012	59884	Ø	15	Sports	GTX	2	110 lbs.
Hyundai	Accent	5 Dr. Hatchback, w/o Factory Roof Rails	2012	59707	Ø	5	Sports	APX	2	100 lbs.
Hyundai	Elantra	4 Dr. Sedan	07-10	59803	Ø	15	Sports	RM	2	110 lbs.
Hyundai	Elantra	Touring 5 Dr., w/Factory Roof Rails	09-11	59897	Ø	15	Sports	RBU	2	165 lbs.
Hyundai	Elantra	Touring 5 Dr., w/Factory Roof Rails		59898	Ø,LA	15	Sports	RBU	2	165 lbs.
Hyundai	Elantra	Touring 5 Dr., w/o Factory Roof Rails	09-11	59800	Ø	15	Sports	GTX	2	110 lbs.
Hyundai	Elantra	4 Dr. Sedan, w/o Factory Roof Rails	2011	59867	Ø	15	Sports	GTX	2	110 lbs.
Hyundai	Elantra Wagon	w/Factory Roof Rails	96-00	59897	Ø	15	Sports	RBU	2	165 lbs.
Hyundai	Elantra Wagon	w/Factory Roof Rails		59898	Ø,LA	15	Sports	RBU	2	165 lbs.
Hyundai	Santa Fe	w/Factory Roof Rails	01-06	59898	Ø	15	Sports	RBU	2	165 lbs.
Hyundai	Santa Fe	w/Factory Roof Rails		59899	Ø,LB	15	Sports	RBU	2	165 lbs.
Hyundai	Santa Fe	w/Factory Roof Rails	07-11	59837	Ø	15	Sports	RE	2	132 lbs.
Hyundai	Sonata		06-10	59835	Ø	15	Sports	RM	2	110 lbs.

ROOF RACK APPLICATION GUIDE

MAKE	MODEL	STYLE	YEAR	PART NO.	FN	INSTALL TIME	RACK DESIGN	MOUNTING SYSTEM	BAR QTY	WEIGHT CAPACITY
Hyundai	Sonata	w/o Factory Roof Rails	2011	59866	Ø	15	Sports	GTX	2	110 lbs.
Hyundai	Tucson	w/Factory Roof Rails	05-09	59836	Ø	15	Sports	RB	2	110 lbs.
Hyundai	Tucson	w/Factory Roof Rails		59898	Ø	15	Sports	RBU	2	165 lbs.
Hyundai	Tucson	w/Factory Roof Rails		59899	Ø,LB	15	Sports	RBU	2	165 lbs.
Hyundai	Tucson	w/Factory Roof Rails	10-11	59898	Ø	15	Sports	RBU	2	165 lbs.
Hyundai	Tucson	w/Factory Roof Rails		59899	Ø,LB	15	Sports	RBU	2	165 lbs.
Hyundai	Tucson	w/Factory Roof Rails	2011	59870	Ø	15	Sports	RBXL	2	165 lbs.
Hyundai	Veracruz	w/Factory Roof Rails	07-11	59898	Ø	15	Sports	RBU	2	165 lbs.
Hyundai	Veracruz	w/Factory Roof Rails		59899	Ø,LB	15	Sports	RBU	2	165 lbs.
Infiniti	EX35	w/Factory Roof Rails	08-11	59897	Ø	15	Sports	RBU	2	165 lbs.
Infiniti	FX35	w/Factory Roof Rails	03-08	59898	Ø	15	Sports	RBU	2	165 lbs.
Infiniti	FX35	w/Factory Roof Rails	09-11	59898	Ø	15	Sports	RBU	2	165 lbs.
Infiniti	FX45	w/Factory Roof Rails	03-08	59898	Ø	15	Sports	RBU	2	165 lbs.
Infiniti	FX50	w/Factory Roof Rails	09-11	59898	Ø	15	Sports	RBU	2	165 lbs.
Infiniti	QX56	w/Factory Roof Rails	2011	59711	Ø	15	Sports	RBU	2	165 lbs.
Isuzu	Rodeo	w/Factory Roof Rails	98-04	59711	Ø,LC	15	Sports	RBU	2	165 lbs.
Isuzu	Rodeo	w/Factory Roof Rails		59899	Ø	15	Sports	RBU	2	165 lbs.
Jeep	Grand Cherokee	w/Factory Roof Rails	99-04	59898	Ø	15	Sports	RBU	2	165 lbs.
Jeep	Grand Cherokee	w/Factory Roof Rails	05-10	59899	Ø	15	Sports	RBU	2	165 lbs.
Jeep	Liberty	w/Factory Roof Rails	02-07	59898	Ø	15	Sports	RBU	2	165 lbs.
Jeep	Liberty	w/Factory Roof Rails		59899	Ø,LB	15	Sports	RBU	2	165 lbs.
Jeep	Liberty	w/Factory Roof Rails	08-11	59711	Ø,LC	15	Sports	RBU	2	165 lbs.
Jeep	Liberty	w/Factory Roof Rails		59899	Ø	15	Sports	RBU	2	165 lbs.
Jeep	Patriot	w/Factory Roof Rails	08-11	59711	Ø,LC	15	Sports	RBU	2	165 lbs.
Jeep	Patriot	w/Factory Roof Rails		59899	Ø	15	Sports	RBU	2	165 lbs.
KIA	Borrego	w/Factory Roof Rails	09-11	59898	Ø	15	Sports	RBU	2	165 lbs.
KIA	Borrego	w/Factory Roof Rails		59899	Ø,LB	15	Sports	RBU	2	165 lbs.
KIA	Forte	4 Dr. Sedan, w/o Factory Roof Rails	10-11	59839	Ø	15	Sports	GTX	2	110 lbs.
KIA	Forte	5 Dr. Hatchback, w/o Factory Roof Rails	2011	59708	Ø	15	Sports	GTX	2	110 lbs.
KIA	Optima	w/o Factory Roof Rails	2011	59896	Ø	15	Sports	GTX	2	110 lbs.
KIA	Rio	4 Dr. Sedan	06-11	59801	Ø	15	Sports	RM	2	110 lbs.
KIA	Rio5	5 Dr. Hatchback Only	06-11	59801	Ø	15	Sports	RM	2	110 lbs.
KIA	Rio5	5 Dr. Hatchback Only, w/o Factory Roof Rails	2012	59712	Ø	5	Sports	GTX	2	110 lbs.
KIA	Rondo	w/Factory Roof Rails	09-11	59809	Ø	15	Sports	RB	2	110 lbs.
KIA	Sedona	w/Factory Roof Rails	06-11	59898	Ø	15	Sports	RBU	2	165 lbs.
KIA	Sedona	w/Factory Roof Rails		59899	Ø,LB	15	Sports	RBU	2	165 lbs.
KIA	Sedona	w/Factory Roof Rails	10-11	59819	Ø	15	Sports	RB	2	110 lbs.
KIA	Sedona	w/Factory Roof Rails		59871	Ø	15	Sports	RB	2	165 lbs.
KIA	Sorento	w/Factory Roof Rails	03-09	59898	Ø	15	Sports	RBU	2	165 lbs.
KIA	Sorento	w/Factory Roof Rails		59899	Ø,LB	15	Sports	RBU	2	165 lbs.
KIA	Sorento	w/Factory Roof Rails	2011	59898	Ø	15	Sports	RBU	2	165 lbs.
KIA	Sorento	w/Factory Roof Rails		59899	Ø,LB	15	Sports	RBU	2	165 lbs.
KIA	Sorento	w/Factory Roof Rails & No Panoramic Sunroof	2011	59868	Ø	15	Sports	RBXL	2	165 lbs.
KIA	Sorento	w/Factory Roof Rails & Panoramic Sunroof	2011	59869	Ø	15	Sports	RBXL	2	165 lbs.
KIA	Soul	w/Factory Roof Rails	10-11	59818	Ø	15	Sports	RB	2	110 lbs.
KIA	Soul	w/o Factory Roof Rails	10-11	59842	Ø	15	Sports	GTX	2	110 lbs.
KIA	Sportage	w/Factory Roof Rails	05-10	59808	Ø	15	Sports	RB	2	110 lbs.
KIA	Sportage	w/Factory Roof Rails		59898	Ø	15	Sports	RBU	2	165 lbs.
KIA	Sportage	w/Factory Roof Rails		59899	Ø,LB	15	Sports	RBU	2	165 lbs.

ROOF RACK APPLICATION GUIDE

MAKE	MODEL	STYLE	YEAR	PART NO.	FN	INSTALL TIME	RACK DESIGN	MOUNTING SYSTEM	BAR QTY	WEIGHT CAPACITY
KIA	Sportage	w/Factory Roof Rails	2011	59849	Ø	5	Sports	REX	2	110 lbs.
Lexus	GX 470	w/Factory Roof Rails	03-09	59898	Ø	15	Sports	RBU	2	165 lbs.
Lexus	GX 470	w/Factory Roof Rails		59899	Ø, LB	15	Sports	RBU	2	165 lbs.
Lexus	RX 330	w/Factory Roof Rails	04-06	59898	Ø	15	Sports	RBU	2	165 lbs.
Lexus	RX 350	w/Factory Roof Rails	07-12	59898	Ø	15	Sports	RBU	2	165 lbs.
Lexus	RX 350	w/Factory Roof Rails	10-12	59817	Ø	5	Sports	RBXL	2	165 lbs.
Lexus	RX 400h	Hybrid w/Factory Roof Rails	06-09	59898	Ø	15	Sports	RBU	2	165 lbs.
Lexus	RX 450h	Hybrid w/Factory Roof Rails	10-11	59898	Ø	15	Sports	RBU	2	165 lbs.
Lincoln	Aviator	w/Factory Roof Rails	03-05	59897	Ø	15	Sports	RBU	2	165 lbs.
Lincoln	Aviator	w/Factory Roof Rails		59898	Ø, LA	15	Sports	RBU	2	165 lbs.
Lincoln	MKX	w/Factory Roof Rails	07-11	59899	Ø	15	Sports	RBU	2	165 lbs.
Lincoln	Navigator	w/Factory Roof Rails	98-06	59898	Ø	15	Sports	RBU	2	165 lbs.
Mazda	2		2011	59830	Ø	5	Sports	APX	2	100 lbs.
Mazda	3	4 Dr. Sedan	04-09	59814	Ø	15	Sports	AP-RM	2	132 lbs.
Mazda	3	5 Dr. Hatchback	04-09	59831	Ø	15	Sports	AP-RM	2	132 lbs.
Mazda	3	4 Dr. Sedan	10-11	59832	Ø	15	Sports	APX	2	132 lbs.
Mazda	3	5 Dr. Hatchback	10-11	59833	Ø	15	Sports	AP-GTX	2	132 lbs.
Mazda	5	All Models	06-10	59834	Ø	15	Sports	APE	2	132 lbs.
Mazda	6	Sport Wagon w/Factory Roof Rails	04-07	59711	Ø, LC	15	Sports	RBU	2	165 lbs.
Mazda	6	Sport Wagon w/Factory Roof Rails		59899	Ø	15	Sports	RBU	2	165 lbs.
Mazda	6	4 Dr. Sedan w/o Factory Roof Rails	09-11	59709	Ø	10	Sports	GTX	2	110 lbs.
Mazda	CX-7		07-11	59821	Ø	15	Sports	APX	2	132 lbs.
Mazda	CX-9		07-11	59822	Ø	15	Sports	APE	2	132 lbs.
Mazda	CX-9	w/Factory Roof Rails	10-11	59711	Ø, LC	15	Sports	RBU	2	165 lbs.
Mazda	CX-9	w/Factory Roof Rails		59899	Ø	15	Sports	RBU	2	165 lbs.
Mazda	MPV Van	w/Factory Roof Rails	99-06	59897	Ø	15	Sports	RBU	2	165 lbs.
Mazda	Tribute	w/Factory Roof Rails	08-11	59711	Ø, LC	15	Sports	RBU	2	165 lbs.
Mazda	Tribute	w/Factory Roof Rails		59899	Ø	15	Sports	RBU	2	165 lbs.
Mercedes-Benz	C240	Wagon w/Factory Roof Rails	03-05	59899	Ø	15	Sports	RBU	2	165 lbs.
Mercedes-Benz	C320	Wagon w/Factory Roof Rails	02-04	59899	Ø	15	Sports	RBU	2	165 lbs.
Mercedes-Benz	E320	Wagon w/Factory Roof Rails	98-05	59899	Ø	15	Sports	RBU	2	165 lbs.
Mercedes-Benz	E350	Wagon w/Factory Roof Rails	06-08	59899	Ø	15	Sports	RBU	2	165 lbs.
Mercedes-Benz	E350	Wagon w/Factory Roof Rails	2011	59899	Ø	15	Sports	RBU	2	165 lbs.
Mercedes-Benz	E500	Wagon w/Factory Roof Rails	04-06	59899	Ø	15	Sports	RBU	2	165 lbs.
Mercedes-Benz	E55 AMG	Wagon w/Factory Roof Rails	2006	59899	Ø	15	Sports	RBU	2	165 lbs.
Mercedes-Benz	E63 AMG	Wagon w/Factory Roof Rails	07-08	59899	Ø	15	Sports	RBU	2	165 lbs.
Mercedes-Benz	GL320 BlueTEC	w/Factory Roof Rails	2009	59899	Ø	15	Sports	RBU	2	165 lbs.
Mercedes-Benz	GL320 CDI	w/Factory Roof Rails	07-08	59899	Ø	15	Sports	RBU	2	165 lbs.
Mercedes-Benz	GL350 BlueTEC	w/Factory Roof Rails	10-11	59899	Ø	15	Sports	RBU	2	165 lbs.
Mercedes-Benz	GL450	w/Factory Roof Rails	07-11	59899	Ø	15	Sports	RBU	2	165 lbs.
Mercedes-Benz	GL550	w/Factory Roof Rails	08-11	59899	Ø	15	Sports	RBU	2	165 lbs.
Mercedes-Benz	GLK350	w/Factory Roof Rails	10-11	59898	Ø	15	Sports	RBU	2	165 lbs.
Mercedes-Benz	GLK350	w/Factory Roof Rails		59899	Ø, LB	15	Sports	RBU	2	165 lbs.
Mercedes-Benz	ML320	w/Factory Roof Rails	98-02	59899	Ø	15	Sports	RBU	2	165 lbs.
Mercedes-Benz	ML320 BlueTEC	w/Factory Roof Rails	2009	59812	Ø	5	Sports	RBXL	2	165 lbs.
Mercedes-Benz	ML320 BlueTEC	w/Factory Roof Rails		59899	Ø	15	Sports	RBU	2	165 lbs.
Mercedes-Benz	ML320 CDI	w/Factory Roof Rails	07-08	59812	Ø	5	Sports	RBXL	2	165 lbs.
Mercedes-Benz	ML320 CDI	w/Factory Roof Rails		59899	Ø	15	Sports	RBU	2	165 lbs.
Mercedes-Benz	ML350	w/Factory Roof Rails	03-05	59899	Ø	15	Sports	RBU	2	165 lbs.

ROOF RACK APPLICATION GUIDE

MAKE	MODEL	STYLE	YEAR	PART NO.	FN	INSTALL TIME	RACK DESIGN	MOUNTING SYSTEM	BAR QTY	WEIGHT CAPACITY
Mercedes-Benz	ML350	w/Factory Roof Rails	06-11	59812	Ø	5	Sports	RBXL	2	165 lbs.
Mercedes-Benz	ML350	w/Factory Roof Rails		59899	Ø	15	Sports	RBU	2	165 lbs.
Mercedes-Benz	ML350 BlueTEC	w/Factory Roof Rails	10-11	59812	Ø	5	Sports	RBXL	2	165 lbs.
Mercedes-Benz	ML350 BlueTEC	w/Factory Roof Rails		59899	Ø	15	Sports	RBU	2	165 lbs.
Mercedes-Benz	ML430	w/Factory Roof Rails	99-01	59899	Ø	15	Sports	RBU	2	165 lbs.
Mercedes-Benz	ML450 Hybrid	w/Factory Roof Rails	10-11	59812	Ø	5	Sports	RBXL	2	165 lbs.
Mercedes-Benz	ML450 Hybrid	w/Factory Roof Rails		59899	Ø	15	Sports	RBU	2	165 lbs.
Mercedes-Benz	ML500	w/Factory Roof Rails	02-05	59899	Ø	15	Sports	RBU	2	165 lbs.
Mercedes-Benz	ML500	w/Factory Roof Rails	06-07	59812	Ø	5	Sports	RBXL	2	165 lbs.
Mercedes-Benz	ML500	w/Factory Roof Rails		59899	Ø	15	Sports	RBU	2	165 lbs.
Mercedes-Benz	ML550	w/Factory Roof Rails	08-11	59812	Ø	5	Sports	RBXL	2	165 lbs.
Mercedes-Benz	ML550	w/Factory Roof Rails		59899	Ø	15	Sports	RBU	2	165 lbs.
Mercedes-Benz	ML63 AMG	w/Factory Roof Rails	07-11	59812	Ø	5	Sports	RBXL	2	165 lbs.
Mercedes-Benz	ML63 AMG	w/Factory Roof Rails		59899	Ø	15	Sports	RBU	2	165 lbs.
Mercury	Mariner	w/Factory Roof Rails	08-11	59897	Ø	15	Sports	RBU	2	165 lbs.
Mercury	Mariner	w/Factory Roof Rails		59898	Ø,LA	15	Sports	RBU	2	165 lbs.
Mercury	Monterey Van	w/Factory Roof Rails	04-07	59897	Ø	15	Sports	RBU	2	165 lbs.
Mercury	Monterey Van	w/Factory Roof Rails		59898	Ø,LA	15	Sports	RBU	2	165 lbs.
MINI	Cooper	Clubman w/Factory Roof Rails	08-11	59897	Ø	15	Sports	RBU	2	165 lbs.
Mitsubishi	Outlander	w/Factory Roof Rails All, Except Outlander Sport	07-11	59899	Ø	15	Sports	RBU	2	165 lbs.
Nissan	Murano	w/Factory Roof Rails	03-07	59823	Ø	5	Sports	RBXL	2	165 lbs.
Nissan	Murano	w/Factory Roof Rails		59898	Ø	15	Sports	RBU	2	165 lbs.
Nissan	Murano	w/Factory Roof Rails		59899	Ø,LB	15	Sports	RBU	2	165 lbs.
Nissan	Murano	w/Factory Roof Rails	09-11	59898	Ø	15	Sports	RBU	2	165 lbs.
Nissan	Murano	w/Factory Roof Rails		59899	Ø,LB	15	Sports	RBU	2	165 lbs.
Nissan	Murano	w/Factory Roof Rails	09-12	59823	Ø	5	Sports	RBXL	2	165 lbs.
Nissan	Quest Mini Van	w/Factory Roof Rails	04-09	59711	Ø,LC	15	Sports	RBU	2	165 lbs.
Nissan	Quest Mini Van	w/Factory Roof Rails		59899	Ø	15	Sports	RBU	2	165 lbs.
Nissan	Quest Mini Van	w/Factory Roof Rails	2011	59711	Ø,LC	15	Sports	RBU	2	165 lbs.
Nissan	Quest Mini Van	w/Factory Roof Rails		59899	Ø	15	Sports	RBU	2	165 lbs.
Nissan	Rogue	w/Factory Roof Rails	08-12	59824	Ø	5	Sports	RBXL	2	165 lbs.
Nissan	Rogue	w/Factory Roof Rails		59898	Ø	15	Sports	RBU	2	165 lbs.
Oldsmobile	Silhouette	w/Factory Roof Rails	97-04	59898	Ø	15	Sports	RBU	2	165 lbs.
Oldsmobile	Silhouette	w/Factory Roof Rails		59899	Ø,LB	15	Sports	RBU	2	165 lbs.
Pontiac	Montana	w/Factory Roof Rails	99-05	59898	Ø	15	Sports	RBU	2	165 lbs.
Pontiac	Montana	w/Factory Roof Rails		59899	Ø,LB	15	Sports	RBU	2	165 lbs.
Pontiac	Montana SV6	w/Factory Roof Rails	05-06	59898	Ø	15	Sports	RBU	2	165 lbs.
Pontiac	Montana SV6	w/Factory Roof Rails		59899	Ø,LB	15	Sports	RBU	2	165 lbs.
Pontiac	Montana SV6	w/Factory Roof Rails (Canada Only)	07-09	59898	Ø	15	Sports	RBU	2	165 lbs.
Pontiac	Montana SV6	w/Factory Roof Rails (Canada Only)		59899	Ø,LB	15	Sports	RBU	2	165 lbs.
Pontiac	Trans Sport Van	w/Factory Roof Rails	97-98	59898	Ø	15	Sports	RBU	2	165 lbs.
Pontiac	Trans Sport Van	w/Factory Roof Rails		59899	Ø,LB	15	Sports	RBU	2	165 lbs.
Pontiac	Vibe	w/Factory Roof Rails	03-10	59897	Ø	15	Sports	RBU	2	165 lbs.
Pontiac	Vibe	w/Factory Roof Rails		59898	Ø,LA	15	Sports	RBU	2	165 lbs.
Porsche	Cayenne	w/Factory Roof Rails	03-11	59898	Ø	15	Sports	RBU	2	165 lbs.
Saab	9-5	Wagon w/Factory Roof Rails	99-09	59898	Ø	15	Sports	RBU	2	165 lbs.
Saab	9-7X	w/Factory Roof Rails	05-09	59898	Ø	15	Sports	RBU	2	165 lbs.
Saturn	L Series	Wagon w/Factory Roof Rails	00-04	59898	Ø	15	Sports	RBU	2	165 lbs.
Saturn	L Series	Wagon w/Factory Roof Rails		59899	Ø,LB	15	Sports	RBU	2	165 lbs.

ROOF RACK APPLICATION GUIDE

MAKE	MODEL	STYLE	YEAR	PART NO.	FN	INSTALL TIME	RACK DESIGN	MOUNTING SYSTEM	BAR QTY	WEIGHT CAPACITY
Saturn	Vue	w/Factory Roof Rails	08-09	59898	Ø	15	Sports	RBU	2	165 lbs.
Subaru	B9 Tribeca	w/Factory Roof Rails	08-11	59899	Ø	15	Sports	RBU	2	165 lbs.
Subaru	Forester	w/Factory Roof Rails	09-11	59826	Ø	15	Sports	RE	2	132 lbs.
Subaru	Forester	w/Factory Roof Rails		59898	Ø	15	Sports	RBU	2	165 lbs.
Subaru	Forester	w/Factory Roof Rails		59899	Ø, LB	15	Sports	RBU	2	165 lbs.
Subaru	Legacy Wagon	All, Inc. Outback w/Factory Roof Rails	95-99	59897	Ø	15	Sports	RBU	2	165 lbs.
Subaru	Outback Wagon	All w/Factory Roof Rails, Except Sport	00-09	59897	Ø	15	Sports	RBU	2	165 lbs.
Suzuki	Esteem	Wagon w/Factory Roof Rails	98-02	59897	Ø	15	Sports	RBU	2	165 lbs.
Suzuki	Foreza	Wagon w/Factory Roof Rails	05-08	59897	Ø	15	Sports	RBU	2	165 lbs.
Suzuki	Grand Vitara	w/Factory Roof Rails	99-05	59897	Ø	15	Sports	RBU	2	165 lbs.
Suzuki	SX4	Crossover w/Factory Roof Rails	07-11	59897	Ø	15	Sports	RBU	2	165 lbs.
Suzuki	Vitara	4 Dr. w/Factory Roof Rails	99-05	59897	Ø	15	Sports	RBU	2	165 lbs.
Suzuki	XL-7	w/Factory Roof Rails	02-06	59897	Ø	15	Sports	RBU	2	165 lbs.
Suzuki	XL-7	w/Factory Roof Rails		59898	Ø, LA	15	Sports	RBU	2	165 lbs.
Toyota	4Runner	w/Factory Roof Rails	03-11	59898	Ø	15	Sports	RBU	2	165 lbs.
Toyota	4Runner	w/Factory Roof Rails		59899	Ø, LB	15	Sports	RBU	2	165 lbs.
Toyota	Camry	4 Dr. Sedan	07-11	59804	Ø	15	Sports	RM	2	110 lbs.
Toyota	Corolla	4 Dr. Sedan, All Models	07-11	59805	Ø	15	Sports	RM	2	130 lbs.
Toyota	FJ Cruiser	w/Factory Roof Rails	07-11	59898	Ø	15	Sports	RBU	2	165 lbs.
Toyota	FJ Cruiser	w/Factory Roof Rails		59899	Ø, LB	15	Sports	RBU	2	165 lbs.
Toyota	Highlander	w/Factory Roof Rails	01-11	59899	Ø	15	Sports	RBU	2	165 lbs.
Toyota	Matrix	w/Factory Roof Rails	03-10	59897	Ø	15	Sports	RBU	2	165 lbs.
Toyota	Matrix	w/Factory Roof Rails		59898	Ø, LA	15	Sports	RBU	2	165 lbs.
Toyota	Prius		04-09	59806	Ø	15	Sports	RM	2	88 lbs.
Toyota	RAV4	w/Factory Roof Rails	01-11	59898	Ø	15	Sports	RBU	2	165 lbs.
Toyota	RAV4	w/Factory Roof Rails		59899	Ø, LB	15	Sports	RBU	2	165 lbs.
Toyota	Sequoia	w/Factory Roof Rails	08-11	59711	Ø	15	Sports	RBU	2	165 lbs.
Toyota	Sienna Van	w/Factory Roof Rails	04-10	59711	Ø, LC	15	Sports	RBU	2	165 lbs.
Toyota	Sienna Van	w/Factory Roof Rails		59899	Ø	15	Sports	RBU	2	165 lbs.
Toyota	Sienna Van	w/Factory Roof Rails	2011	59898	Ø	15	Sports	RBU	2	165 lbs.
Toyota	Sienna Van	w/Factory Roof Rails		59899	Ø, LB	15	Sports	RBU	2	165 lbs.
Volkswagen	Golf Wagon	Canada Only w/Factory Roof Rails	10-11	59820	Ø	5	Sports	RBXL	2	165 lbs.
Volkswagen	Golf Wagon	Canada Only w/Factory Roof Rails		59897	Ø	15	Sports	RBU	2	165 lbs.
Volkswagen	Golf Wagon	Canada Only w/Factory Roof Rails		59898	Ø, LA	15	Sports	RBU	2	165 lbs.
Volkswagen	Jetta	4 Dr. Sedan (New Body Style)	05-10	59807	Ø	15	Sports	RM	2	88 lbs.
Volkswagen	Jetta	SportWagen w/Factory Roof Rails	09-11	59820	Ø	5	Sports	RBXL	2	165 lbs.
Volkswagen	Jetta	SportWagen w/Factory Roof Rails		59897	Ø	15	Sports	RBU	2	165 lbs.
Volkswagen	Jetta	SportWagen w/Factory Roof Rails		59898	Ø, LA	15	Sports	RBU	2	165 lbs.
Volkswagen	Jetta Wagon	w/Factory Roof Rails	01-06	59897	Ø	15	Sports	RBU	2	165 lbs.
Volkswagen	Jetta Wagon	w/Factory Roof Rails		59898	Ø, LA	15	Sports	RBU	2	165 lbs.
Volkswagen	Jetta Wagon	Canada Only w/Factory Roof Rails	2009	59820	Ø	5	Sports	RBXL	2	165 lbs.
Volkswagen	Jetta Wagon	Canada Only w/Factory Roof Rails		59897	Ø	15	Sports	RBU	2	165 lbs.
Volkswagen	Jetta Wagon	Canada Only w/Factory Roof Rails		59898	Ø, LA	15	Sports	RBU	2	165 lbs.
Volkswagen	Passat Wagon	w/Factory Roof Rails	90-97	59897	Ø	15	Sports	RBU	2	165 lbs.
Volkswagen	Passat Wagon	w/Factory Roof Rails	1998	59897	Ø	15	Sports	RBU	2	165 lbs.
Volkswagen	Passat Wagon	w/Factory Roof Rails	99-05	59897	Ø	15	Sports	RBU	2	165 lbs.
Volkswagen	Passat Wagon	w/Factory Roof Rails	07-10	59897	Ø	15	Sports	RBU	2	165 lbs.
Volkswagen	Rabbit	4 Dr. Only	07-09	59811	Ø	15	Sports	RM	2	88 lbs.
Volkswagen	Tiguan	w/Factory Roof Rails	09-11	59898	Ø	15	Sports	RBU	2	165 lbs.



C H O O S E Y O U R

The Standard of Excellence for Jacks



The **BULLDOG** Heavy Duty Jack product offering is the most popular & extensive in the industry. The BULLDOG jack is characterized by unmatched strength, reliability, safety and value.



Fulton Jacks are widely regarded as "Best in Class" for light to medium duty applications.

Time-tested & application proven, Fulton's innovation satisfies the consumer's demand for both performance & style.



Pro Series Jacks represent a big value at an affordable price. Pro Series Jacks are value engineered for light to medium duty applications.



JACKS

A-Frame Jacks with Powered Drive

Round Jacks

Square Jacks

Powered Drive Kit

2-Speed Tandem Landing Gear

Fifth Wheel Landing Gear System

Rack / Gear Jacks

Jack Replacement Parts

F2® Marine / Recreational Jacks

F2® A-Frame Jack and Coupler Combination

Marine and Recreational Jacks

Multi-Jack

Stabilizers

COUPLERS

Heavy Duty Collar-Lok™ Couplers

Heavy Duty Cast Couplers

BX1 Gooseneck Couplers

Gooseneck Couplers

SAE International J2638 Standard

Stamped Couplers

Fold-Away™ Couplers / Hinge Kits

WINCHES

How to Select a Hand Winch

F2® Single and Two Speed Trailer Winches

Single Speed Trailer Winches

Two Speed Trailer Winches

Brake Winches

Worm Gear Winches

Winch - Accessories, Repair/Service Kits

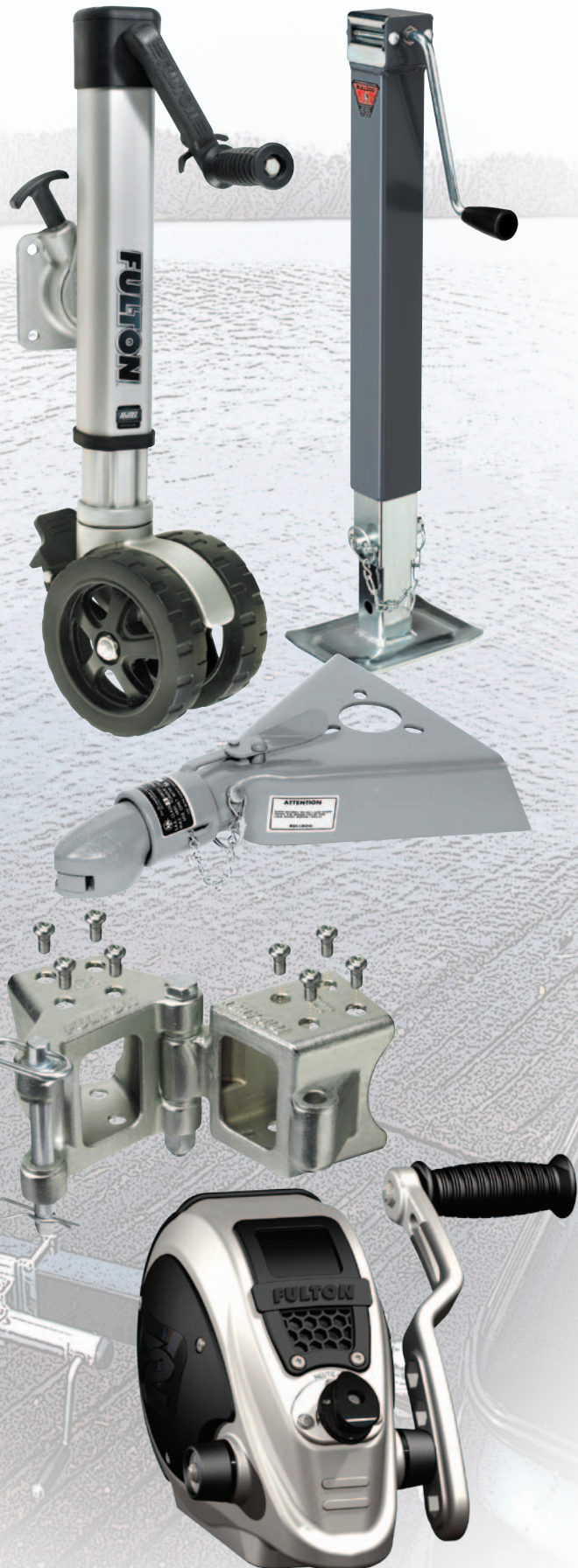



500187

500188

A-FRAME JACK WITH POWERED DRIVE

Tough & Trusted BULLDOG jacks present a Powered Jack with all the capacity and features you want.

- Positions quickly with 22" of total travel
- 3500 lb. lift capacity
- Integrated gearbox and motor
- Drop leg
- Deploys and hooks up easily at night with onboard LED courtesy light, angled to illuminate coupler
- Works in case of power loss with emergency manual override capability, easily accessible from the top, crank included
- Lasts for years with industry-leading BULLDOG performance, known worldwide for unmatched strength, durability, and side load capacity
- Limited 5-year warranty

A-FRAME JACK WITH POWERED DRIVE

Part No.	Lift Cap. (lbs.)	Travel	Measurements			Description	Packaging	Lbs.
			Retracted	Extended	Clearance			
500187	3,500	14"	9.75"	31.50"	20.50"	Black Cover, includes Drop Leg and Manual Override Crank	Ind. Pack	20
500188	3,500	14"	9.75"	31.50"	20.50"	White Cover, includes Drop Leg and Manual Override Crank	Ind. Pack	20



500185

500186

A-FRAME JACK WITH POWERED DRIVE

Tough & Trusted BULLDOG jacks present a Powered Jack with all the capacity and features you want.



- Positions quickly with 25" of total travel - 17" screw travel and 8" drop leg travel
- Heavy duty 4000 lb. lift capacity
- Makes setting up easier with a handy built-in level right where you need it most
- Deploys and hooks up easily at night with onboard LED courtesy light
- Works in case of power loss with emergency manual override capability, easily accessible from the top
- Conserves battery power
- Lasts for years with industry-leading BULLDOG performance, known worldwide for unmatched strength, durability, and side load capacity
- Retains like-new appearance with corrosion-resistant surfaces
- Limited 5-year warranty

A-FRAME JACK WITH POWERED DRIVE

Part No.	Lift Cap. (lbs.)	Travel	Measurements			Description	Pkg.	Lbs.
			Retracted	Extended	Clearance			
500185	4,000	17"	9.75"	34.50"	24.00"	White Cover, includes Drop Leg	Ind. Pack	23
500186	4,000	17"	9.75"	34.50"	24.00"	Black Cover, includes Drop Leg	Ind. Pack	23



Built-In Level

Emergency Manual Override

Replacement Service Parts

Part No.	Description	Packaging
500190	Drop leg and pin kit.	Ind. Pack
500191	Manual override crank bolt kit.	Polybag
500192	Bottom cover and screws.	Polybag
500193	Level assembly and screws.	Polybag
500194	Manual override cover kit.	Polybag
500196	LED light assembly and bulb.	Polybag



500198

A-FRAME JACK WITH POWERED DRIVE

- 18" travel.
- Integrated circuit breaker.
- Works in case of power loss with supplied manual override crank handle.
- Gloss black painted outer tube and motor assembly, clear zinc inner tube.
- Limited 1-year warranty.



A-FRAME JACK WITH POWERED DRIVE

Part No.	Lift Cap. (lbs.)	Travel	Measurements			Description	Pkg.	Lbs.
			Retracted	Extended	Clearance			
500198	2,500	18"	8.50"	26.50"	N/A	Powered A-Frame Jack without Footplate, Manual Override Crank Included	Ind. Pack	20



ROUND JACKS

BULLDOG round jacks are recognized as the industry standard by leading agricultural, commercial, horse, livestock, and other trailer manufacturers. For more than three quarters of a century, BULLDOG jacks have been demonstrated to be the most reliable, field-proven jacks on the market.

- Smooth, comfortable, ergonomic design
- Dependable vertical and side load capacity
- Proven reliability for long term use at rated loads
- Precision fitted parts for extra stability
- A-Frame models listed have grey painted outer and inner tubes - All other models have grey painted outer and clear zinc inner tubes
- Custom finishes are available upon request



155022

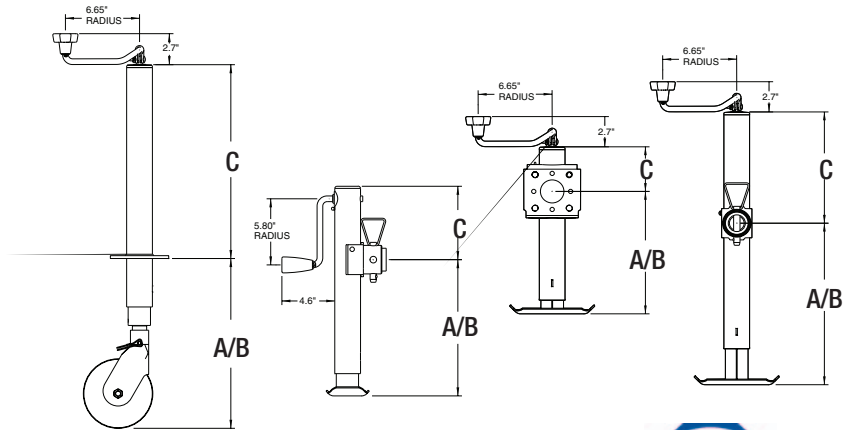

Travel and Clearance Diagram
 A= Retracted B= Extended C= Clearance Height



THE CHOICE WHEN
 APPLICATION REQUIRES
 COMPLIANCE WITH
 ASABE S485 STANDARDS



151401



178201



STANDARD ROUND JACKS - TUBULAR SWIVEL - ROUND

Part No.	Model No.	Lift Cap. (lbs.)	Handle Style	Travel	Measurements			Description	Lbs.
					A Retracted	B Extended	C Clearance		
158451 ♦	TWS 158 DTSF w/P&C	2,000	Topwind	10"	11.00"	21.00"	4.00"	Weld-on tubular mount with 9/16" pin and foot plate. Male mating mount included.	13.5
158452 ♦	TWL 158 DTSF w/P&C	2,000	Topwind	15"	14.50"	29.50"	10.00"	Weld-on tubular mount with 9/16" pin and foot plate. Male mating mount included.	16.0
150441	TWS 150 DTSFX w/P&C	2,000	Topwind	10"	11.00"	21.00"	4.00"	Weld-on tubular mount, with 9/16" pin and foot plate. Clear zinc finish. Mating mount sold separately.	10.0
158488	TWL 150 DTSF w/P&C	2,000	Topwind	15"	16.00"	31.00"	4.00"	Weld-on tubular mount with 9/16" pin and foot plate. Clear zinc finish. Male mating mount included.	14.2
158109	SWS 158 DTSF w/P&C	2,000	Sidewind	10"	10.80"	20.80"	6.40"	Weld-on tubular mount with 9/16" pin and foot plate. Male mating mount included.	14.0
158151 ♦	SWL 158 DTSF w/P&C	2,000	Sidewind	15"	14.50"	29.50"	12.20"	Weld-on tubular mount with 9/16" pin and foot plate. Male mating mount included.	16.0
178101 ♦	TWS 178 DTSF w/P&C	5,000	Topwind	10"	11.25"	21.25"	4.00"	Weld-on tubular mount with 9/16" pin and foot plate. Male mating mount included.	14.5
178151	TWL 178 DTSF w/P&C	5,000	Topwind	15"	14.70"	29.70"	10.00"	Weld-on tubular mount with 9/16" pin and foot plate. Male mating mount included.	18.0
178201 ♦	SWS 178 DTSF w/P&C	5,000	Sidewind	10"	10.40"	20.40"	6.40"	Weld-on tubular mount with 5/8" pin and foot plate. Male mating mount included.	15.0
178203	SWL 178 DTSF w/P&C	5,000	Sidewind	15"	15.40"	30.40"	6.40"	Weld-on tubular mount with 5/8" pin and foot plate. Male mating mount included.	18.0
198100	TWS 198 DTSM w/P&C	7,000	Topwind	10"	10.80"	20.80"	4.50"	Weld-on tubular mount with 5/8" pin and foot plate. Female mating mount included.	17.0
198200	TWL 198 DTSM w/P&C	7,000	Topwind	15"	15.80"	30.80"	4.25"	Weld-on tubular mount with 5/8" pin and foot plate. Female mating mount included.	20.0
198150 ♦	SWS 198 DTSM w/P&C	7,000	Sidewind	10"	11.00"	21.00"	6.40"	Weld-on tubular mount with 5/8" pin and foot plate. Female mating mount included.	19.0
198250	SWL 198 DTSM w/P&C	7,000	Sidewind	15"	16.00"	31.00"	6.40"	Weld-on tubular mount with 5/8" pin and foot plate. Female mating mount included.	21.0

STANDARD ROUND JACKS - A-FRAME

Part No.	Model No.	Lift Cap. (lbs.)	Handle Style	Travel	Measurements			Description	Lbs.
					A Retracted	B Extended	C Clearance		
155022 ♦	TWL 155	2,000	Topwind	15"	8.80"	23.80"	12.20"	Weld-on/bolt-on bracket. Less wheel or base.	12.5
155028	TWL 155	2,000	Topwind	15"	8.40"	23.40"	13.00"	Weld-on/bolt-on bracket. Less wheel or base. Clear zinc finish.	12.5
155033	TWL 155X	2,000	Topwind	15"	5.40"	20.40"	16.00"	Weld-on/bolt-on bracket. Less wheel or base.	12.5
155157 ♦	SWL 155X (RV)	2,000	Sidewind	13"	8.60"	21.50"	13.00"	External gear box. Handle to front. Weld-on/bolt-on bracket. Less wheel or base.	14.0
1550100317	SWL 155 X	3,000	Sidewind	13"	7.00"	20.00"	14.50"	Weld-on/bolt-on bracket. Less wheel or base.	14.0
1550101344	SWL 155 X	3,000	Sidewind	13"	7.00"	20.00"	14.50"	Weld-on/bolt-on bracket. Less wheel or base. Clear zinc finish.	14.0
155032 ♦	TWL 155 HD	5,000	Topwind	15"	10.30"	25.30"	10.20"	Weld-on/bolt-on bracket. Less wheel or base. (5000 lb. vertical load capacity)	13.3
1750290317 ♦	TWL 175	5,000	Topwind	15"	10.82"	25.82"	10.70"	Weld-on/bolt-on bracket. Less wheel or base.	13.3
1750290301	TWL 175	5,000	Topwind	15"	10.82"	25.82"	10.70"	Weld-on/bolt-on bracket. Less wheel or base. Clear zinc finish.	13.3
1700100317	SWL 175	5,000	Sidewind	15"	8.60"	23.60"	12.75"	Weld-on/bolt-on bracket. Less wheel or base.	15.5

NOTE: Review price list or contact customer service for package quantities and full part number. Other custom-made designs are available upon request.

♦ DENOTES MOST POPULAR



155157



158451



STANDARD ROUND JACKS - WELD-ON RETAINING RING SWIVEL

Part No.	Model No.	Lift Capacity	Handle Style	Travel	Measurements			Description	Lbs.
					A Retracted	B Extended	C Clearance		
151401 ♦	TWS 151 DS	2,000	Topwind	10"	11.00"	21.00"	4.00"	Weld-on L-bend swivel bracket assembled. 1/2" diameter plunger pin. With footplate.	13.0
151421	TWL 151 DS	2,000	Topwind	15"	14.50"	29.50"	10.00"	Weld-on L-bend swivel bracket assembled. 1/2" diameter plunger pin. With footplate.	16.0
151460	TWS 151 DS	2,000	Topwind	10"	11.00"	21.00"	4.00"	3/8" diameter plunger pin. With footplate. Clear zinc finish. WELD-ON L-BEND SWIVEL BRACKET SOLD SEPARATELY.	11.4
151101 ♦	SWS 151 DS	2,000	Sidewind	10"	11.00"	21.00"	6.40"	Weld-on L-bend swivel bracket assembled. 1/2" diameter plunger pin. With footplate.	13.0
151159	SWL 151 DS	2,000	Sidewind	15"	14.50"	29.50"	12.20"	Weld-on L-bend swivel bracket assembled. 1/2" diameter plunger pin. With footplate.	17.0
171401	TWS 171 DS	5,000	Topwind	10"	11.25"	21.25"	4.00"	Weld-on L-bend swivel bracket assembled. 1/2" diameter plunger pin. With footplate.	14.0
171412	TWL 171 DS	5,000	Topwind	15"	14.50"	29.50"	10.00"	Weld-on L-bend swivel bracket assembled. 1/2" diameter plunger pin. With footplate.	17.0

STANDARD ROUND JACKS - BOLT-ON RETAINING RING SWIVEL

Part No.	Model No.	Lift Capacity	Handle Style	Travel	Measurements			Description	Lbs.
					A Retracted	B Extended	C Clearance		
151443 ♦	TWS 159 SX	2,000	Topwind	10"	11.00"	21.00"	4.00"	Bolt-on swivel bracket assembled with mounting hardware. 1/2" diameter plunger pin. Without base. Fits tongue up to 3" x 4".	12.25

STANDARD ROUND JACKS - WITHOUT MOUNT

Part No.	Model No.	Lift Capacity	Handle Style	Travel	Measurements			Description	Lbs.
					A Retracted	B Extended	C Clearance		
150152	SWL 150	2,000	Sidewind	15"	26.60"	41.60"	N/A	No foot, no mount, painted outer tube, zinc inner tube.	13.0
150000	TWL 150	2,000	Topwind	10"	15.00"	25.00"	N/A	No foot, no mount, painted outer tube, zinc inner tube.	7.2
1701480317	TWL 170	5,000	Topwind	15"	21.00"	36.00"	N/A	No foot, no mount, painted outer tube, zinc inner tube.	11.45
170205	SWL 170	5,000	Sidewind	15"	19.20"	34.20"	N/A	No foot, no mount, painted outer tube, zinc inner tube.	12.14

STANDARD ROUND JACKS - BOLT-ON FIXED MOUNT

Part No.	Model No.	Lift Capacity	Handle Style	Travel	Measurements			Description	Lbs.
					A Retracted	B Extended	C Clearance		
1511180301	SWL 151 DSX	2,000	Sidewind	15"	6.5"	21.50"	20.25"	Clear zinc finish. With footplate. Mounting hardware NOT included.	16.40

NOTE: Review price list or contact Customer Service for package quantities and full part number. Other custom-made designs are available upon request.

♦ DENOTES MOST POPULAR





0050240300

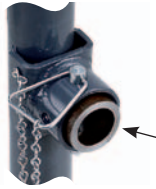

500239

ROUND JACK MOUNTING OPTIONS

Part No.	Description	Style
P9222-00	Weld-on retaining ring swivel mount	Weld-on
0050240300	Female tubular swivel mount, 5/8" hole	Weld-on
500239	Male tubular swivel mount, 9/16" hole	Weld-on
0031350300	A-frame bottom support plate	Weld-on



500256



500105 / 500171

ROUND JACK HANDLE OPTIONS

Part No.	Description
500256	Sidewind
500105	Sidewind
500180	Topwind
500148	Topwind
500171	Sidewind



500180



500148



017125



CE555 0301

ROUND JACK WHEEL / FOOT OPTIONS

Part No.	Description
017125	Removable steel caster. Reduces overall jack capacity to 1,000 lbs.
CE555 0101	Removable polyolefin caster. Reduces overall jack capacity to 1,200 lbs. (boxed)
CE555 0301	Removable polyolefin caster. Reduces overall jack capacity to 1,200 lbs. (bulk)
500244	Detachable base, 2.1" height
018098	Detachable base, 6.2" height
500245	Removable 6" caster with pin. Fits jacks with 2" inner tube



500244

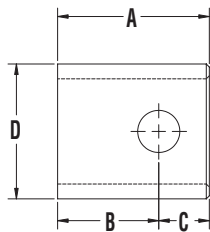

Tube Mount Diagram



0152790300

TUBE MOUNTS

Part No.	Style	Pin Diameter	Measurements				Fits
			A	B	C	D	
0050050300	Weld-on, male	9/16"	2.25"	1.50"	0.75"	2.00"	2.50"
0152790300	Weld-on, male	5/8"	2.25"	1.50"	0.75"	2.00"	2.50"
0050240300	Weld-on, female	5/8"	2.50"	1.62"	0.88"	3.00"	2.50"
0152730300	Weld-on, male	9/16"	1.88"	1.13"	0.75"	2.00"	2.50"
0152710300	Weld-on, female	9/16"	1.62"	0.88"	0.75"	2.50"	2.00"
0031550300	Weld-on, female	3/4"	3.00"	1.59"	1.41"	3.25"	2.50"
7011800300	Weld-on, male	7/8"	3.31"	1.90"	1.41"	2.50"	3.25"
005122	Weld-on, female	7/8"	2.80"	1.58"	1.22"	4.00"	3.25"
005164	Weld-on, female	5/8"	2.50"	1.50"	1.00"	3.00" sq.	2.50" sq.
PQM19-00	Weld-on, male	5/8"	2.13"	1.25"	0.88"	2.00" sq.	2.50" sq.



ROUND JACKS

- Designed for use with trailers with A-Frame couplers
- Weld-on or Bolt-on mounting option
- A-frame models have black painted outer and inner tubes, all other models have black painted outer and clear zinc inner tubes

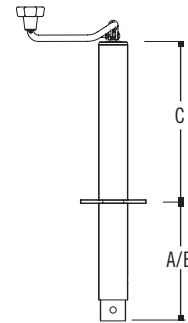

Travel and Clearance
 A = Retracted
 B = Extended
 C = Clearance Height

Actual product may vary slightly from image shown.

STANDARD ROUND JACKS - A-FRAME WITHOUT FOOTPLATE

Part No.	Lift Capacity	Handle Style	Travel	A Retracted	Measurements B Extended	C Clearance	Description	Lbs.
RV20000103	2,000	Sidewind	14"	9.00"	23.00"	13.00"	Front Facing Handle, Boxed	12.00
RV20000303	2,000	Sidewind	14"	9.00"	23.00"	13.00"	Front Facing Handle	12.00
EA20000103	2,000	Topwind	14"	8.00"	22.00"	11.00"	Boxed	11.00
EA20000303	2,000	Topwind	14"	8.00"	22.00"	11.00"		11.00
EA20000340	2,000	Topwind	14"	8.00"	22.00"	11.00"	Clear Zinc Inner & Outer Tubes	11.00
1401000303	2,000	Topwind	15"	5.50"	20.50"	16.00"		12.50
1400600303	5,000	Topwind	15"	10.80"	25.80"	14.55"		13.00

Unless otherwise noted, A-Frame Without Footplate Jacks: 1) Finish is black painted inner and outer tubes 2) Jacks are bulk packed



1400750340

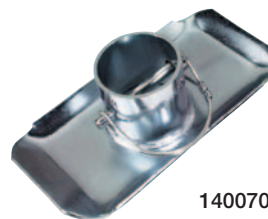

1400700340

STANDARD ROUND JACKS - A-FRAME ACCESSORIES

Part No.	Capacity	Description	Lbs.
1400700340	5,000	Removable Footplate, 2.10" Tall, Fits 2" Inner Tube, Includes Pull Pin Assembly, Clear Zinc Finish	2.50
1400750340	1,200	Removable 6" Caster, Includes Pull Pin Assembly, Clear Zinc Finish	4.00



ROUND JACKS

- Designed for use with recreational and utility trailers
- Bolt-on versions include all necessary mounting hardware
- Weld-on versions include mating mount and retaining ring
- A-frame models have black painted outer and inner tubes, all other models have black painted outer and clear zinc inner tubes

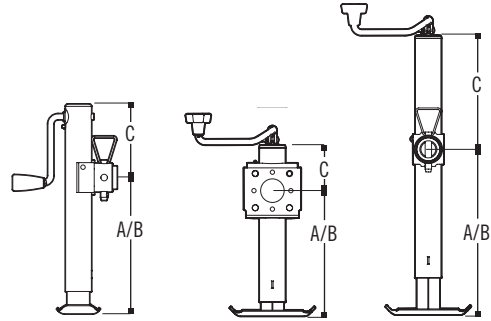

Travel and Clearance
 A = Retracted
 B = Extended
 C = Clearance Height

Actual product may vary slightly from image shown.

STANDARD ROUND JACKS - RETAINING RING SWIVEL, BOLT-ON, WITH FOOTPLATE

Part No.	Lift Capacity	Handle Style	Travel	Measurements			Description	Lbs.
				A Retracted	B Extended	C Clearance		
1400300303	2,000	Topwind	10"	11.00"	21.00"	4.00"	Mounting Hardware Included	14.25

STANDARD ROUND JACKS - RETAINING RING SWIVEL, WELD-ON, WITH FOOTPLATE

Part No.	Lift Capacity	Handle Style	Travel	Measurements			Description	Lbs.
				A Retracted	B Extended	C Clearance		
1401140303	2,000	Topwind	10"	11.00"	21.00"	4.00"	Mating Mount & Retaining Ring Included	11.00
1401040303	2,000	Topwind	15"	14.50"	29.50"	10.00"	Mating Mount & Retaining Ring Included	15.00
1401020303	2,000	Sidewind	10"	10.40"	20.40"	6.29"	Mating Mount & Retaining Ring Included	12.00
1401030303	2,000	Sidewind	15"	14.40"	29.40"	12.25"	Mating Mount & Retaining Ring Included	16.00

STANDARD ROUND JACKS - TUBULAR SWIVEL, WELD-ON, WITH FOOTPLATE

Part No.	Lift Capacity	Handle Style	Travel	Measurements			Description	Lbs.
				A Retracted	B Extended	C Clearance		
1401060303	2,000	Sidewind	10"	11.20"	21.20"	5.45"	Mating Mount & Pull Pin Included	11.50
1401080303	2,000	Sidewind	15"	14.40"	29.40"	12.25"	Mating Mount & Pull Pin Included	15.50
1400400303	2,000	Topwind	10"	11.00"	21.00"	4.00"	Mating Mount & Pull Pin Included	11.00
1401200303	2,000	Topwind	15"	14.50"	29.50"	10.00"	Mating Mount & Pull Pin Included	15.00
1401420303	5,000	Sidewind	10"	10.50"	20.50"	6.25"	Mating Mount & Pull Pin Included	12.00
1401440303	5,000	Sidewind	15"	15.50"	30.50"	6.25"	Mating Mount & Pull Pin Included	15.00
1401460303	5,000	Topwind	10"	11.20"	21.20"	4.00"	Mating Mount & Pull Pin Included	12.50
1401480303	5,000	Topwind	15"	14.70"	29.70"	10.00"	Mating Mount & Pull Pin Included	16.50

Unless otherwise noted, A-Frame Without Footplate Jacks: 1) Finish is black painted inner and outer tubes 2) Jacks are bulk packed



SQUARE JACKS

Square Up for Side Load Strength

Compared to round jacks of similar capacities, BULLDOG's 5,000 lb. support capacity square jack dramatically improves side load strength while maintaining the economical benefits of lower capacity jacks. The extra side load capacity you need without the costs of increasing overall capacity.

- 12-gauge square tube is 70% stronger than 12-gauge round tube for more side load and support strength with the same lift capacity
- 4.62" outer tube overlap at full extension for additional side load strength
- Weather-resistant materials and coatings. Painted outer tubes, clear zinc inner tubes
- Proven, reliable mechanical elements provide dependable strength and long-lasting, durable performance
- Mounts included in this series of jacks



THE CHOICE WHEN
APPLICATION REQUIRES
COMPLIANCE WITH
ASABE S485 STANDARDS



195356

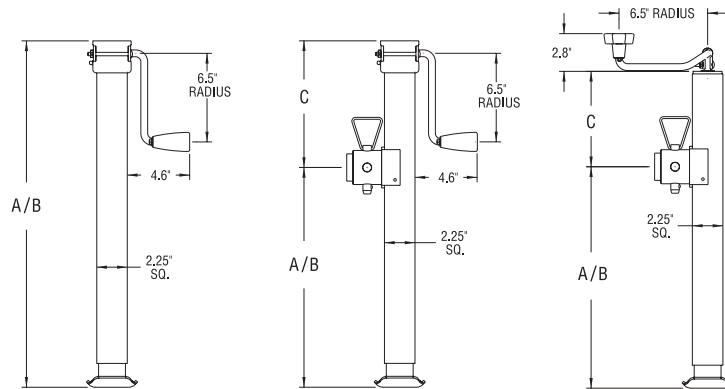

Travel and Clearance Diagram

A= Retracted B= Extended C= Clearance Height



195312



195321



SQUARE JACKS - TUBULAR SWIVEL MOUNT - ROUND

5,000 LBS. SUPPORT CAPACITY - 3,000 LBS. LIFT CAPACITY

Part No.	Model No.	Support Capacity	Handle Style	Travel	Measurements			Description	Lbs.
					A Retracted	B Extended	C Clearance		
195306 ♦	TWL 195 DTSFQ	5,000	Topwind	15"	15.20"	30.20"	7.00"	Fixed leg with base. With tubular swivel mount (includes male mating mount, pin, and chain).	17.5
195356 ♦	SWL 195 DTSFQ w/P&C	5,000	Sidewind	15"	15.10"	30.10"	9.25"	Fixed leg with base. With tubular swivel mount (includes male mating mount, pin, and chain).	18.5

Patent Pending. NOTE: Contact Price List or Customer Service for package quantities and full part number. ♦ DENOTES MOST POPULAR

SQUARE JACKS - TUBULAR SWIVEL MOUNT - SQUARE

5,000 LBS. SUPPORT CAPACITY - 3,000 LBS. LIFT CAPACITY

Part No.	Model No.	Support Capacity	Handle Style	Travel	Measurements			Description	Lbs.
					A Retracted	B Extended	C Clearance		
195312 ♦	TWL 195 DTSXFQ w/P&C	5,000	Topwind	15"	15.20"	30.20"	7.00"	Fixed leg with base. Square mount welded to outer tube (includes male mating mount, pin, and chain).	17.5
195362	SWL 195 DTSXFQ w/P&C	5,000	Sidewind	15"	15.10"	30.10"	9.25"	Fixed leg with base. Square mount welded to outer tube (includes male mating mount, pin, and chain).	18.4

Patent Pending. NOTE: Contact Price List or Customer Service for package quantities and full part number. ♦ DENOTES MOST POPULAR

SQUARE JACKS - A-FRAME

5,000 LBS. SUPPORT CAPACITY - 3,000 LBS. LIFT CAPACITY

Part No.	Model No.	Support Capacity	Handle Style	Travel	Measurements			Description	Lbs.
					A Retracted	B Extended	C Clearance		
195318	TWL 195 DL-DFXQ	5,000	Topwind	15"	7.90"	36.50"	14.70"	Drop leg with base. Drop leg offers 13.50" additional adjustment.	19.3
195321 ♦	TWL 195 FL-FXQ	5,000	Topwind	15"	7.40"	22.40"	14.70"	Fixed leg less base. Drop leg offers 13.50" additional adjustment.	13.8
195322	TWL 195 DL-DFXQ	5,000	Topwind	15"	7.90"	36.50"	14.70"	Drop leg with base. Drop leg offers 13.50" additional adjustment. Zinc-plated inner and outer tubes.	19.3

Patent Pending. NOTE: Contact Price List or Customer Service for package quantities and full part number. ♦ DENOTES MOST POPULAR

SQUARE JACKS - DIRECT WELD

5,000 LBS. SUPPORT CAPACITY - 3,000 LBS. LIFT CAPACITY

Part No.	Model No.	Support Capacity	Handle Style	Travel	Measurements			Description	Lbs.
					A Retracted	B Extended	C Clearance		
195301 ♦	TWL 195 DQ	5,000	Topwind	15"	22.20"	37.20"	N/A	Fixed leg with base.	14.1
195304 ♦	TWL 195 DL-DXQ	5,000	Topwind	15"	22.60"	51.20"	N/A	Drop leg with base. Drop leg offers 13.50" additional adjustment.	18.2
195319	TWL 195 FL-BXQ	5,000	Topwind	15"	22.30"	37.30"	N/A	Fixed leg with caster base.	14.1
195320	TWL 195 FL-XQ	5,000	Topwind	15"	22.10"	37.10"	N/A	Fixed leg less base.	12.7
195352	SWL 195 DQ	5,000	Sidewind	15"	24.40"	39.40"	N/A	Fixed leg with base.	16.1
195354 ♦	SWL 195 DL-DXQ	5,000	Sidewind	15"	25.50"	54.10"	N/A	Drop leg with base. Drop leg offers 13.50" additional adjustment.	20.2
195368	SWL 195 FL-XQ	5,000	Sidewind	15"	24.40"	39.40"	N/A	Fixed leg with caster base.	16.1
195369	SWL 195 FL-XQ	5,000	Sidewind	15"	24.20"	39.20"	N/A	Fixed leg less base.	14.7

Patent Pending. NOTE: Contact Price List or Customer Service for package quantities and full part number. ♦ DENOTES MOST POPULAR



THE CHOICE WHEN APPLICATION REQUIRES COMPLIANCE WITH ASABE S485 STANDARDS

SQUARE JACKS

BULLDOG's 8,000 lb. support capacity square jack serves the agricultural, industrial, construction, horse/livestock trailer, and utility/cargo trailer markets. We have packed "Big Jack Power" into this compact design! The compact design of these jacks makes them ideal for tight-fitting applications where 3" and 4" square tube jacks are too big! This is a perfect transition from BULLDOG's round jack product line.

- Use the painted outer tube as the final finish or primer
- Zinc-plated inner tube and drop leg
- 4.7" Outer / inner tube overlap - results in optimal side load performance
- 5/8" screw stem - provides insurance against screw stem twisting off
- Patented screw nut stop - prevents screw and/or nut damage when jack is fully extended
- Topwind models - bushing in top cap, eagle claw grip
- Sidewind models - 1/4" cross pin connects gear train to screw stem - guards against shearing jack pin
- Sidewind models - 1:1.33 gear ratio



190705

190754



Travel and Clearance Diagram
 A= Retracted
 B= Extended
 C= Clearance Height

SQUARE JACKS - TUBULAR SWIVEL MOUNT

8,000 LBS. SUPPORT CAPACITY - 5,000 LBS. LIFT CAPACITY

Part No.	Model No.	Support Capacity	Handle Style	Travel	Measurements			Description	Lbs.
					A Retracted	B Extended	C Clearance		
190705 ♦	TWS 190 FL-B TSMQ w/P&C	8,000	Topwind	10"	11.41"	21.41"	4.25"	Fixed leg with heavy-duty base. With tubular swivel mount (includes mating mount, pin and chain).	18.0
190706	TWL 190 FL-B TSMQ w/P&C	8,000	Topwind	15"	12.16"	27.16"	10.25"	Fixed leg with heavy-duty base. With tubular swivel mount (includes mating mount, pin and chain).	22.5
190708	TWL 190 DL-B TSMQ w/P&C	8,000	Topwind	15"	12.66"	41.16"	10.25"	Drop leg with heavy-duty base. Drop leg offers 13.50" additional adjustment. With tubular swivel mount (includes mating mount, pin and chain).	27.0
190756 ♦	SWL 190 FL-B TSMQ w/P&C	8,000	Sidewind	15"	12.16"	27.16"	12.40"	Fixed leg with heavy-duty base. With tubular swivel mount (includes mating mount, pin and chain).	24.0
190758	SWL 190 DL-B TSMQ w/P&C	8,000	Sidewind	15"	12.66"	41.16"	12.40"	Drop leg with heavy-duty base. Drop leg offers 13.50" additional adjustment. With tubular swivel mount (includes mating mount, pin and chain).	28.5

SQUARE JACKS - DIRECT WELD

8,000 LBS. SUPPORT CAPACITY - 5,000 LBS. LIFT CAPACITY

Part No.	Model No.	Support Capacity	Handle Style	Travel	Measurements			Description	Lbs.
					A Retracted	B Extended	C Clearance		
190704 ♦	TWL 190 DL-BQ	8,000	Topwind	15"	22.66"	51.41"	N/A	Drop leg with heavy-duty base. Drop leg offers 13.50" additional adjustment.	23.5
190754 ♦	SWL 190 DL-BQ	8,000	Sidewind	15"	25.06"	53.56"	N/A	Drop leg with heavy-duty base. Drop leg offers 13.50" additional adjustment.	25.0

Patent Pending. NOTE: Other custom-made designs are available upon request. ♦ DENOTES MOST POPULAR



SQUARE JACKS

BULLDOG 10,000 lb. support capacity square jacks "fills the gap" between 8,000 lb. and 12,000 lb. square jack product offerings. If the existing 8,000 lb. support capacity square jacks are too small or the 12,000 lb. support capacity square jacks are too big, look no further – your application and pricing requirements have been met! This is the highest quality and best performing jack available in the marketplace today, a total balance between capacity, speed, and effort.

- Heavy-gauge 3" square tubing allows for direct weld mounting wherever the application allows – no burn through
- Use the painted outer tube as the final finish or primer
- Zinc-plated inner tube and drop leg
- Heavy-duty base, with reinforcement ribs, zero water retention
- Precision manufactured for long term reliability and smooth, easy cranking
- Grease zerk for easy lubrication as needed
- Oil-impregnated bushing for improved bearing and gear life
- Direct weld to outer tube is standard
- Sidewind models - 1:1.86 gear ratio



THE CHOICE WHEN APPLICATION REQUIRES COMPLIANCE WITH ASABE S485 STANDARDS

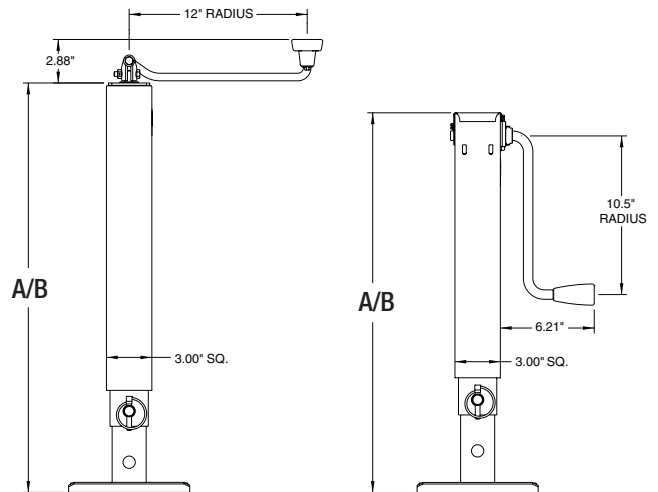

Travel and Clearance Diagram
A= Retracted B= Extended

SQUARE JACKS - DIRECT WELD

10,000 LBS. SUPPORT CAPACITY - 7,200 LBS. LIFT CAPACITY

Part No.	Model No.	Support Capacity	Handle Style	Travel	Measurements		Description	Lbs.
					A Retracted	B Extended		
180304 ♦	TWS 180 DL-BQ	10,000	Topwind	10"	18.18"	38.31"	Drop leg with heavy-duty base. Drop leg offers 10.12" additional adjustment.	24.5
180354	TWL 180 DL-BQ	10,000	Topwind	15"	22.93"	51.43"	Drop leg with heavy-duty base. Drop leg offers 13.50" additional adjustment.	30.0
180455 ♦	SWL 180 DL-BQ	10,000	Sidewind	15"	25.67"	54.17"	Drop leg with heavy-duty base. Drop leg offers 13.50" additional adjustment.	32.5

Patent Pending. NOTE: Contact Price List or Customer Service for package quantities and full part number. Other custom-made designs are available upon request. ♦ DENOTES MOST POPULAR

HEAVY DUTY SQUARE JACKS

HEAVY DUTY SQUARE JACKS

Strong, durable, and sturdy, the BULLDOG 12,000 lb. support capacity square jack is the BIG reason why BULLDOG has carried the load in agricultural, construction, heavy-duty utility, and horse/livestock trailer industries since 1923. All BULLDOG 4" square jacks are rated for 12,000 lb. support capacity and 10,000 lb. lift capacity. The strength of the product, plus the wide variety of styles, makes this jack the best choice in its product class.

- 4" square tubing, 7-gauge superior alloy steel
- Painted outer tube, inner tube, and drop leg
- Drop leg option with 5 positioning holes
- Easy-access gear box with grease fitting for routine maintenance
- Spring return drop leg or non-spring return drop leg
- 12.5" screw travel, 13.5" of additional adjustment with drop leg
- Front facing drop leg plunger pin or side facing drop leg plunger pin
- Painted (with or without labels) or powder paint optional
- Sidewind models - 1:1.5 gear ratio

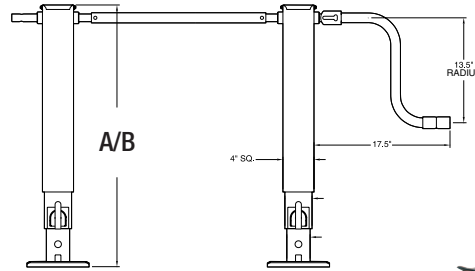

Pin to front tandem application

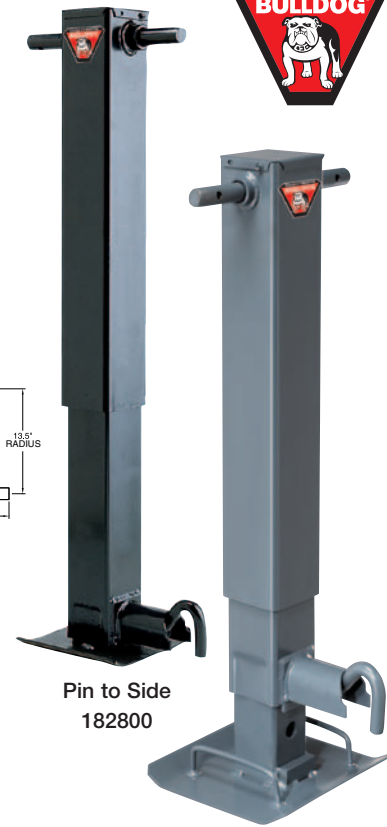

Pin to Side
182800

Travel and Clearance Diagram

A= Retracted

B= Extended

C= Clearance Height

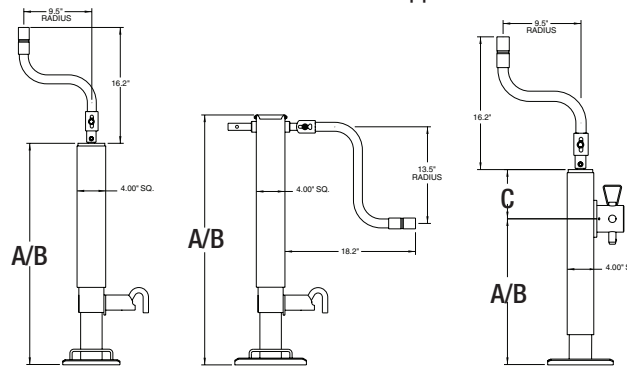

Pin to Front
182415

SQUARE JACKS - DIRECT WELD - NON-SPRING RETURN

12,000 LBS. SUPPORT CAPACITY - 10,000 LBS. LIFT CAPACITY

Part No.	Model No.	Support Capacity	Handle Style	Travel	Measurements			Description	Lbs.
					A Retracted	B Extended	C Clearance		
182300	TWQ 180 DL-B	12,000	Topwind	12.5"	23.4"	49.4"	N/A	Drop leg jack with standard disc foot. 13.5" of additional drop leg extension. Crank sold separately.	50.0
182304 ♦	TWQ 180 DL-BC	12,000	Topwind	12.5"	23.4"	49.4"	N/A	Drop leg jack with standard disc foot. 13.5" of additional drop leg extension. Crank included.	53.0
182400 ♦	SWQ 180 DL-B	12,000	Sidewind	12.5"	27.4"	53.3"	N/A	Drop leg jack with standard disc foot. 13.5" of additional drop leg extension. Drop leg pull pin to the SIDE. Crank sold separately.	58.0
182404	SWQ 180 DL-BC	12,000	Sidewind	12.5"	27.4"	53.3"	N/A	Drop leg jack with standard disc foot. 13.5" of additional drop leg extension. Drop leg pull pin to the SIDE. Crank included.	61.5
182411	SWQ 180 DL-B	12,000	Sidewind	12.5"	27.4"	53.5"	N/A	Drop leg jack with standard disc foot. 13.5" of additional drop leg extension. Drop leg pull pin to the SIDE. Crank sold separately. Companion jack to 182400 and 182404.	58.0
182415 ♦	SWQ 180 DL-BX	12,000	Sidewind	12.5"	28.6"	54.6"	N/A	Drop leg jack with standard disc foot. 13.5" of additional dropleg extension. Drop leg pull pin to the FRONT. Crank sold separately.	58.0
182500	SWQ 180 FL-B	12,000	Sidewind	12.5"	27.0"	39.5"	N/A	Fixed leg jack with standard disc foot. Crank sold separately.	47.0

Patent Pending. NOTE: Contact Price List or Customer Service for package quantities and full part number. Other custom-made designs are available upon request. ♦ DENOTES MOST POPULAR

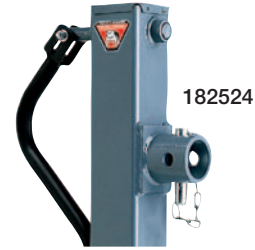

SQUARE JACKS - DIRECT WELD - SPRING RETURN

12,000 LBS. SUPPORT CAPACITY - 10,000 LBS. LIFT CAPACITY

Part No.	Model No.	Support Capacity	Handle Style	Travel	Measurements			Description	Lbs.
					A Retracted	B Extended	C Clearance		
182800 ♦	SWQ 180 DL-B-SR	12,000	Sidewind	12.5"	27.4"	53.6"	N/A	Drop leg jack with standard disc foot. 13.5" of additional drop leg extension. Drop leg pull pin to the SIDE. Crank sold separately.	57.4
182804	SWQ 180 DL-BC-SR	12,000	Sidewind	12.5"	27.4"	53.6"	N/A	Drop leg jack with standard disc foot. 13.5" of additional drop leg extension. Drop leg pull pin to the SIDE. Includes crank.	60.9
182805	SWQ 180 DL-BX RH	12,000	Sidewind	12.5"	27.4"	53.5"	N/A	Drop leg jack with standard disc foot. 13.5" of additional drop leg extension. Drop leg pull pin to the SIDE. Crank sold separately. Companion jack to 182800, 182802, and 182804	57.4
182815 ♦	SWQ 180 DL-BX	12,000	Sidewind	12.5"	28.6"	54.6"	N/A	Drop leg jack with standard disc foot. 13.5" of additional drop leg extension. Drop leg pull pin to the FRONT. Crank sold separately.	58.0

Patent Pending. NOTE: Contact Price List or Customer Service for package quantities and full part number. Other custom-made designs are available upon request. ♦ DENOTES MOST POPULAR

SQUARE JACKS - TUBULAR SWIVEL - NON-SPRING RETURN

12,000 LBS. SUPPORT CAPACITY - 10,000 LBS. LIFT CAPACITY

Part No.	Model No.	Support Capacity	Handle Style	Travel	Measurements			Description	Lbs.
					A Retracted	B Extended	C Clearance		
182524	SWQ 180 TS-FL-BCX	12,000	Sidewind	12.5"	17.0"	29.6"	10.1"	Fixed leg jack with standard disc foot. Includes crank. Includes 3.25" diameter tube mount with pin and chain. Does not include mating mount (005122).	52.0

Patent Pending. NOTE: Contact Price List or Customer Service for package quantities and full part number. Other custom-made designs are available upon request. ♦ DENOTES MOST POPULAR



005122
Female Mating Mount
(Purchased separately)



701466

REMOVABLE CRANKS

Part No. 701466

- Non-slotted design for better weather resistance and 2-speed performance
- Remains firmly attached for convenience or may be removed easily for theft deterrence
- Fits 1" schedule 40 steel pipe for remote mounting

ACCESSORIES - 12,000 LB. SUPPORT CAPACITY JACKS

Part No.	Description	Lbs.
005122	Weld-on female mount for 7/8" pull pin. 4.00" O.D., 3.375" I.D., 2.75" long.	3.0
015181	Sidewind crank assembly with 13.50" radius. Vertical clevis. Mounting hardware included. Extends 17.50" from the jack. Black primed finish.	3.5
800102	Sidewind crank assembly with 13.50" radius. Horizontal clevis. Mounting hardware included. Extends 17.50" from the jack. Black primed finish.	3.5
800075	Topwind crank assembly with 9.50" radius. Vertical clevis. Mounting hardware included. Extends 15.50" from the top of the jack. Black primed finish.	3.0
800090	Sidewind crank assembly with 13.50" radius. Horizontal clevis. Mounting hardware included. Extends 17.50" from the jack. Black primed finish.	4.5
701466	Removable sidewind crank with 13.5" offset radius. All zinc-plated crank. Dual handle grips for cranking and shifting. For use with OEM supplied out-board bushing or may be attached directly on jack gearbox. Needs 012378 adapter with traditional gearbox.	4.0
CS730300	Cross shaft extension tube 72.75" to connect jacks in tandem application	10.0

2-SPEED SQUARE JACKS

2-SPEED SQUARE JACKS

The First 2-Speed Gearbox Designed with a Drop Leg Jack in Mind.

BULLDOG's 2-speed 12,000 lb. support capacity square jack makes cranking easier when fully loaded and faster when unloaded. In low gear, the ratio delivers full lifting power at a super-smooth, easy-lifting 27 turns per 1" (planetary) and 29 turns per 1" (traditional) of travel. In high gear, the cranking ratio is a speedy 9 turns per 1" of travel, the fastest in its weight class.

- State of the art 2 speed gearbox with power and speed for the most effective and efficient jack at all loads
- Designed for today's standard agricultural, construction and industrial trailer applications.
- User friendly design makes operation smooth and easy
- Engineered alloys for enhanced strength, stability and sideload capability
- Planetary gearbox fits within the width profile of the jack's outer tube, eliminating the need for spacers

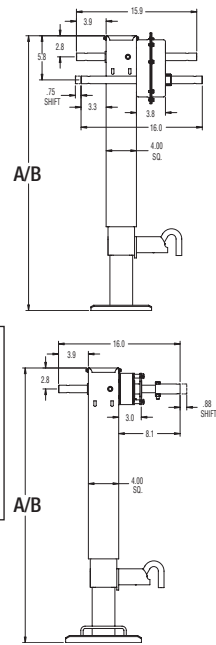

Award Winning Design - 2004 ASABE AE50 Award & Wisconsin 2004 Governor's Award

183816 Planetary

183902 Traditional

2-SPEED SQUARE JACKS - DIRECT WELD

12,000 LBS. SUPPORT CAPACITY - 10,000 LBS. LIFT CAPACITY

Part No.	Model No.	Support Capacity	Gearbox Style	Travel	Measurements		Description	Companion	Lbs.
					A Retracted	B Extended			
NON-SPRING RETURN									
183401	SWQ 183 DL-BX	12,000	Planetary	12.5"	28.5"	54.6"	2-Speed, drop leg with standard disc foot. 13.50" additional drop leg extension. Drop leg pull pin to the SIDE. Painted outer tube, inner tube, and drop leg. Crank sold separately.	182411	67.0
183416	SWQ 183 DL-BX	12,000	Planetary	12.5"	29.5"	55.6"	2-Speed, drop leg with standard disc foot. 13.50" additional drop leg extension. Drop leg pull pin to the FRONT. Painted outer tube, inner tube, and drop leg. Crank sold separately.	182415	67.0
183900	SWQ 180 DL-B	12,000	Traditional	12.5"	28.5"	54.6"	2-Speed, drop leg with standard disc foot. 13.50" additional drop leg extension. Drop leg pull pin to the SIDE. Painted outer tube, inner tube, and drop leg. Crank sold separately.	182411	77.0
183901	SWQ 180 DL-BX T	12,000	Traditional	12.5"	29.5"	55.6"	2-Speed, drop leg with standard disc foot. 13.50" additional drop leg extension. Drop leg pull pin to the FRONT. Painted outer tube, inner tube, and drop leg. Crank sold separately.	182415	77.0
SPRING RETURN									
183816	SWQ 183 DL-BX w/SR	12,000	Planetary	12.5"	29.5"	55.6"	2-Speed, drop leg with standard disc foot. 13.50" additional drop leg extension. Drop leg pull pin to the FRONT. Painted outer tube, inner tube, and drop leg. Crank sold separately.	182815	65.0
183902	SWQ 180 DL-B w/SR T	12,000	Traditional	12.5"	28.5"	54.6"	2-Speed, drop leg with standard disc foot. 13.50" additional drop leg extension. Drop leg pull pin to the SIDE. Painted outer tube, inner tube, and drop leg. Crank sold separately.	182805	77.0
183903	SWQ 180 DL-BX w/SR T	12,000	Traditional	12.5"	29.5"	55.6"	2-Speed, drop leg with standard disc foot. 13.50" additional drop leg extension. Drop leg pull pin to the FRONT. Painted outer tube, inner tube, and drop leg. Crank sold separately.	182815	77.0
REPLACEMENT PART									
500285	-	-	-	-	-	-	Replacement part, planetary two speed sun gear	-	-

NOTE: Contact Price List or Customer Service for package quantities and full part number.



POWERED DRIVE KIT

DESIGNED SPECIFICALLY FOR USE WITH BULLDOG 12,000 LB. JACKS
7500 LB. LIFT CAPACITY

LIFTS **50%** MORE THAN COMPETITION

- Lifts 3" per minute at typical working loads
- Can be manually cranked in the event of power loss
- **State of the art 12VDC electric motor**
- Quiet operation – 50% quieter than competitive units
- Efficient use of electrical power - 60% more efficient than competitive units
- Permanently lubricated to provide years of maintenance free use
- **Custom designed wiring harness & rocker switch enclosed in a weather proof box**
- Utilizes a 25 amp circuit breaker with push button reset feature
- **Can be used in both single & tandem jack applications**
- **Kit includes all necessary components for ease of installation**
- Powered drive assembly
- Torque stop tube with energy absorption device
- Replacement bevel gear & dowel pin
- Terminal box
- Wiring harness & switch box
- Hex coupling (not shown, required when using in a tandem jack application)
- Weather resistant cover (not shown)

- **COMPACT DESIGN**
- **LIGHTWEIGHT ALUMINUM GEARBOX**



- **WELD-ON TORQUE STOP TUBE**

Part Number 1824200100
 Aftermarket Single Speed Jack Applications

Part Number 1824210100
 OEM Single Speed jack Applications

Part Number 1824180100
 OEM 2 Speed Planetary Jack Applications



IDEAL FOR HORSE, LIVESTOCK, AND HEAVY DUTY TRAILERS



NOTE: Designed for use with BULLDOG 12,000 lb. jacks only. Not compatible with Pro Series or other jacks.



SQUARE JACKS

Square Up for Side Load Strength

- Square jack dramatically improves side load strength
- Drop leg and fixed leg models available
- Tubular swivel models include mating mount and pull pin

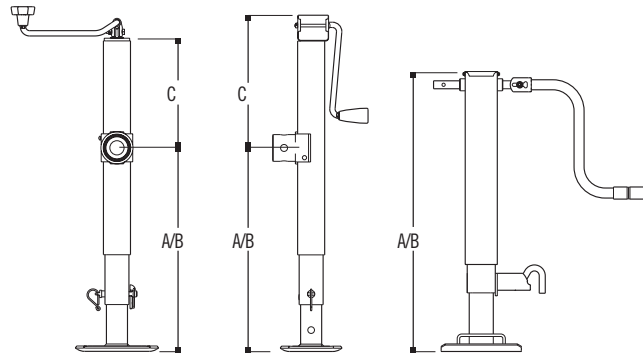

Travel and Clearance

A = Retracted B = Extended C = Clearance Height

Actual product may vary slightly from image shown.

SQUARE JACKS - WELD-ON - TUBULAR SWIVEL

Part No.	Support Capacity	Handle Style	Travel	Measurements			Description	Lbs.
				A Retracted	B Extended	C Clearance		
1401520383	5,000	Topwind	10"	17.20"	27.20"	5.00"	Finish is black painted outer tube, clear zinc inner tube. Fixed leg.	17.00
1401610383	5,000	Sidewind	10"	17.40"	27.40"	8.00"	Finish is black painted outer tube, clear zinc inner tube. Fixed leg.	18.00
1400830383	8,000	Topwind	10"	17.20"	27.20"	5.00"	Finish is black painted outer tube, clear zinc inner tube. Fixed leg.	17.00
1400860383	8,000	Sidewind	10"	17.10"	27.10"	7.30"	Finish is black painted outer tube, clear zinc inner tube. Fixed leg.	18.00

SQUARE JACKS - DIRECT WELD

Part No.	Support Capacity	Handle Style	Travel	Measurements			Description	Lbs.
				A Retracted	B Extended	C Clearance		
1401500383	5,000	Topwind	15"	22.60"	51.20"	n/a	Finish is black painted outer tube, clear zinc inner tube and 28" travel with drop leg.	20.00
1401600383	5,000	Sidewind	15"	25.80"	54.40"	n/a	Finish is black painted outer tube, clear zinc inner tube and 28" travel with drop leg.	21.00
1400800383	8,000	Topwind	15"	22.90"	51.50"	n/a	Finish is black painted outer tube, clear zinc inner tube and 28" travel with drop leg.	20.00
1400850383	8,000	Sidewind	15"	25.20"	53.80"	n/a	Finish is black painted outer tube, clear zinc inner tube and 28" travel with drop leg.	21.00
140094	12,000	Sidewind	12.5"	27.25"	53.25"	n/a	Spring return drop leg, 26" travel with drop leg, pin to side, crank included. Finish is gray painted outer tube, inner tube, and drop leg.	62.00
1400950376	12,000	Sidewind	12.5"	28.25"	54.25"	n/a	Spring return drop leg, 26" travel with drop leg, pin to front, crank included. Finish is gray painted outer tube, inner tube, and drop leg.	62.00
1400960376	12,000	Sidewind	12.5"	28.25"	54.25"	n/a	Spring return drop leg, 26" travel with drop leg, pin to front. Finish is gray painted outer tube, inner tube, and drop leg.	59.00
1400980376	12,000	Sidewind	12.5"	28.25"	54.25"	n/a	Non spring return drop leg, 26" travel with drop leg, pin to front, crank included. Finish is gray painted outer tube, inner tube, and drop leg.	61.00
1400990376	12,000	Sidewind	12.5"	28.25"	54.25"	n/a	Non spring return drop leg, 26" travel with drop leg, pin to front. Finish is gray painted outer tube, inner tube, and drop leg.	58.00
1401010376	12,000	Sidewind	12.5"	28.25"	54.25"	n/a	Non spring return drop leg, 26" travel with drop leg, pin to side, crank included. Finish is gray painted outer tube, inner tube, and drop leg.	61.00

Accessory Part

Part No.	Description	Lbs.
1400920383	12K Crank, Mounting Hardware & Clip, Black Painted Finish	3.00

HEAVY DUTY 2-SPEED TANDEM LANDING GEAR

- AAR & TTMA rated (all values per pair):
45,000 lbs. lifting capacity
(@ 100 ft. lbs. input torque)
90,000 lbs. static capacity
- Competitive Cranking ratios:
Low speed gear 27.3 turns per inch
High speed gear 4.5 turns per inch
- 17" of Travel
- High efficiency, double lead screw
- Heavy duty, self-leveling sand shoe
- Crank included – cross shaft sold separately
- Black painted finish
- Industry leading 5-year warranty



Shown with standard TTMA mount, mounted to outside of frame

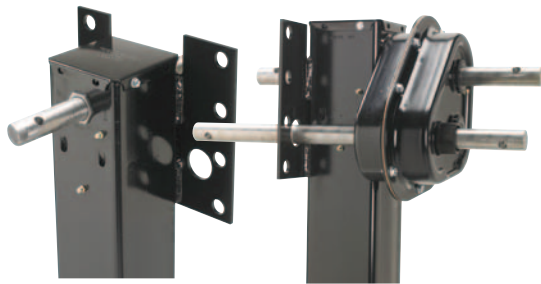

Easy-access grease fittings



Ideal for horse, livestock and heavy duty trailers



Shown with standard TTMA mount, mounted to inside of frame



Heavy duty leg band for added strength. Sand shoe designed to maximize connection strength.

HEAVY DUTY 2-SPEED TANDEM LANDING GEAR

90,000 LBS. SUPPORT CAPACITY - 45,000 LBS. LIFT CAPACITY

Part No.	Support Capacity	Description	Travel	Measurements	
				A Retracted	B Extended
500153	90,000	Tandem Non Drop Leg Landing Gear - Set includes Direct Weld 2-Speed & Single Speed Jacks & Crank. Cross Shaft not included.	17"	31.7"	48.7"
500154	90,000	Tandem Non Drop Leg Landing Gear - Set includes TTMA Bolt-On Mount 2-Speed & Single Speed Jacks & Crank. Cross Shaft not included.	17"	31.7"	48.7"
1839050383		2-Speed Jack, Direct Weld. Crank sold separately.	17"	31.7"	48.7"
1839060383		2-Speed Jack, TTMA Bolt-On Mount. Crank sold separately.	17"	31.7"	48.7"
1823050383		Single Speed Jack, Direct Weld. Crank sold separately.	17"	31.7"	48.7"
1823060383		Single Speed Jack, TTMA Bolt-On Mount. Crank sold separately.	17"	31.7"	48.7"
8001090283		Crank, Mounting hardware included.			
CS730300		72.75" Cross Shaft, Slotted Ends, Hardware Included			

FIFTH WHEEL LANDING GEAR SYSTEM

- Traditional Single Drive System
- Heavy gauge 6" x 8" self-leveling footplates with drain holes to prevent corrosion
- Spring loaded drop leg pin on 8000 lb. support capacity model
- Includes secondary gearbox
- 36" total travel
- Includes adjustable cross shaft
- Includes 4 mounting brackets and 4 sets of mounting hardware
- Motor, switch and harness must be obtained separately
- Industry leading 5-year warranty



FIFTH WHEEL LANDING GEAR SYSTEM

Part No.	Support Capacity	Lift Capacity	Description	Measurements	
				Total Lift	Screw Travel
500158	6,500	4,000	RV Landing Gear Assembly (Motor, Switch and Harness Must Be Obtained Separately)	36"	18"
500162	8,000	4,000	RV Landing Gear Assembly (Motor, Switch and Harness Must Be Obtained Separately)	36"	18"

DUAL OUTPUT POWERED DRIVE FIFTH WHEEL LANDING GEAR SYSTEM

- Dual Output Powered Drives
- High speed position installation results in lifting speeds of 9"/minute
- Heavy duty integrated die-cast gearbox eliminates the need for an intermediate plastic gear box
- Spring loaded drop leg pin
- Independent leg control for leveling
- Heavy gauge 6" x 8" self-leveling footplates
- 36" total travel
- Includes motors preassembled to jacks
- Includes dual switch panel and wiring harness
- Includes 4 mounting brackets and 4 sets of mounting hardware
- Industry leading 5-year warranty



DUAL OUTPUT POWERED DRIVE FIFTH WHEEL LANDING GEAR SYSTEM

10,000 LBS. SUPPORT CAPACITY

Part No.	Support Capacity	Lift Capacity	Description	Motor & Switches	Measurements	
					Total Lift	Screw Travel
500170	10,000	7,000	RV Landing Gear Assembly	2	36"	18"
500161	10,000	10,000	RV Landing Gear Assembly	2	36"	18"

RACK / GEAR JACKS

750 lb. A-Frame & BOLT-ON

BULLDOG experience and engineering know-how have produced a line of rack and gear jacks that are tough and trusted, the most preferred jacks used by trailer manufacturers in a variety of industries.

- Smooth-cranking 4 turns per inch of travel
- Strong, durable design
- All-welded steel gear box
- Proven reliability for long term use at rated loads
- Weather-resistant clear zinc-plated rack post
- Gray primer-painted steel wheel and gear box
- Custom designs available

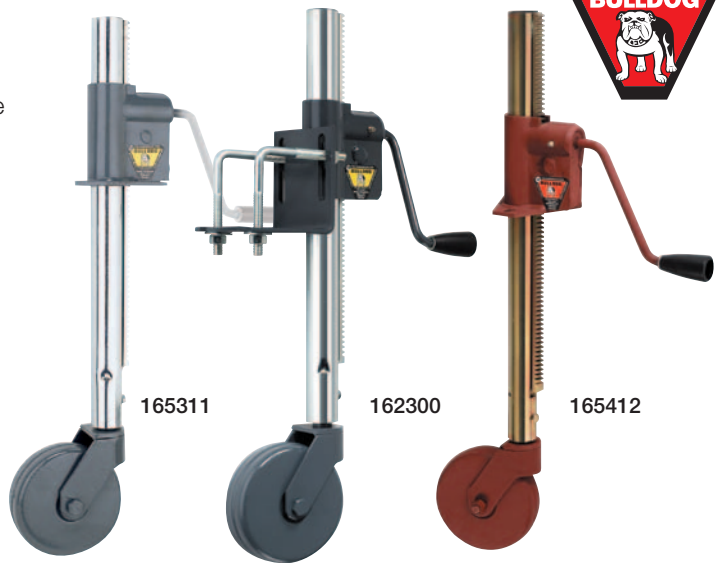

1,200 lb. Heavy-Duty

These heavy-duty rack jacks exemplify BULLDOG's reputation for strength, providing additional lift capacity to a full 1,200 pounds. Specially designed and manufactured to BULLDOG's unparalleled standards, they are ideal for heavier trailers and greater tongue weights.

- Smooth-cranking 4 turns per inch of travel
- Powerful heavy-duty gear box
- Special steel alloy helical gear for extra lift capacity
- Extra heavy-duty gauge post for maximum side load strength
- Specially designed gusseted caster bracket for increased stability
- Superior extension capabilities (up to 26.5" on the HD165WX model, the highest in the industry and ideal for use with big 4x4 trucks)
- Weather-resistant yellow zinc-plated rack post
- Red oxide primer-painted steel wheel and gear box
- Custom designs available

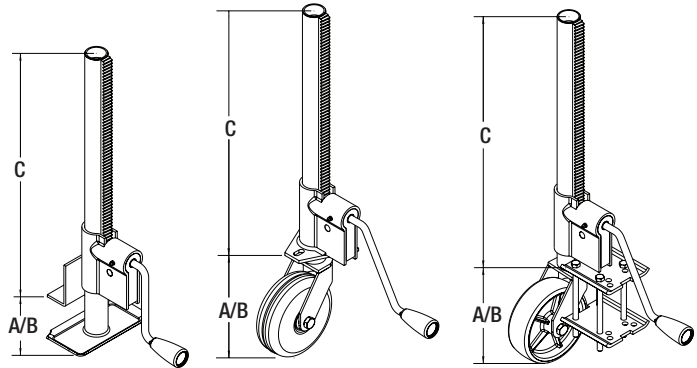

Travel and Clearance Diagram
A= Retracted B= Extended C= Clearance Height

MOUNTING OPTIONS

L-BEND BRACKET WELD-ON

Welds to side and bottom of tongue



161 Series

L-BEND BRACKET BOLT-ON

Fits up to 4" square tongue



162 Series

A-FRAME

Welds or bolts to top of A-frame coupler



165 Series

BOLT-ON

Fits up to 3" x 5" rectangular tongue



169 Series

WHEEL / FOOT OPTIONS

CASTER WHEELS

Polyolefin Wheel
750 lb. capacity



"R" Models

Steel Wheel
750 lb. capacity
1,200 lb. capacity - heavy-duty

"W" Models



DISC FOOT

Welded to Jack Post
750 lb. capacity

"D" Models





STANDARD RACK / GEAR JACKS - L-BEND WELD-ON – 161 SERIES

Part No.	Model No.	Lift Capacity	Includes		Travel	Measurements			Description	Lbs.
			*Gear Box	*Rack Post		A Retracted	B Extended	C Clearance		
161100 ♦	161 D	750	018161	018230-01	16"	2.5"	18.5"	21.2"	Weld-on L-bend bracket, with disc foot.	11.4
161300 ♦	161 W	750	018161	018006	16"	6.5"	22.5"	21.2"	Weld-on L-bend bracket, with steel wheel.	13.7

STANDARD RACK / GEAR JACKS - L-BEND BOLT-ON – 162 SERIES

Part No.	Model No.	Lift Capacity	Includes		Travel	Measurements			Description	Lbs.
			*Gear Box	*Rack Post		A Retracted	B Extended	C Clearance		
162300 ♦	162 W	750	019032	018006	16"	6.0"	22.0"	21.8"	Bolt-on L-bend bracket, with steel wheel.	16.7

STANDARD RACK / GEAR JACKS - A-FRAME – 165 SERIES

Part No.	Model No.	Lift Capacity	Includes		Travel	Measurements			Description	Lbs.
			*Gear Box	*Rack Post		A Retracted	B Extended	C Clearance		
165111 ♦	165 D	750	018155	018230-01	16"	3.5"	19.5"	20.2"	A-frame weld-on/bolt-on bracket, with disc foot.	11.1
165211	165 R	750	018155	018007	16"	7.5"	23.5"	20.3"	A-frame weld-on/bolt-on bracket, with polyolefin wheel.	12.3
165311 ♦	165 W	750	018155	018006	16"	7.5"	23.5"	20.3"	A-frame weld-on/bolt-on bracket, with steel wheel.	13.4
165411 ♦	HD 165 W	1,200	019141	019060	16"	7.5"	23.5"	20.3"	Heavy-duty A-frame weld-on/bolt-on bracket, with heavy-duty 21" long 1,200 pound rack and post, with steel wheel.	14.4
165412	HD 165 WX	1,200	019141	019080	19"	7.5"	26.5"	23.3"	Heavy-duty A-frame weld-on/bolt-on bracket, with heavy-duty 24" long 1,200 pound rack and post, with steel wheel.	15.1

STANDARD RACK / GEAR JACKS - RECTANGULAR BOLT-ON – 169 SERIES

Part No.	Model No.	Lift Capacity	Includes		Travel	Measurements			Description	Lbs.
			*Gear Box	*Rack Post		A Retracted	B Extended	C Clearance		
169201 ♦	169 RB	750	018191	018308	16"	7.5"	23.5"	20.3"	Bolt-on mount, fits up to 3" x 5" tongue, with mounting kit and polyolefin wheel, black finish.	14.9

*Gear boxes and rack post also sold separately. ♦ DENOTES MOST POPULAR

NOTE: Contact Price List or Customer Service for package quantities and full part number. Other custom-made designs are available upon request.



WHEELS



0917501S00

CE555 0101

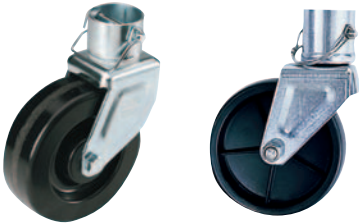

CP555 0301

500245



018507

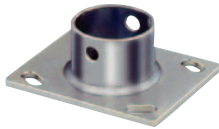

CA5550301



0031350300

Part No.	Description	Pkg.
POLY WHEELS		
0917501S00	6" poly wheel only – 750 - 1,200 lbs. rated	Bulk
CE555 0101	6" caster with 2" inside diameter fitting for 2" jack tube – 1,200 lbs. rated	Boxed
CE555 0301	6" caster with 2" inside diameter fitting for 2" jack tube – 1,200 lbs. rated	Bulk
500245	6" caster with pin 2" inside diameter fitting for 2" jack tube - 1,200 lbs. rated	Clam
HEAVY-DUTY PHENOLIC WHEELS		
CP555 0301	6" caster with 2" inside diameter fitting for 2" jack tube – 1,500 lbs. rated	Bulk
STEEL WHEELS (REDUCES RATED CAPACITIES OF ANY JACK)		
017125	Caster assembly w/6" steel wheel, fits 2" inner tube – 750 - 1,000 lbs. rated	Bulk
018507	Caster assembly w/6" steel wheel for 155159 and 155300 – 1,000 lbs. rated	Poly Bag

CASTER ADAPTER PLATES

Part No.	Description	Pkg.
CASTER ADAPTER PLATES		
CA5550301	Caster adapter plate	Bulk

BOTTOM SUPPORT PLATES

Part No.	Description	Pkg.
BOTTOM SUPPORT PLATES		
0031350300	A-frame support plate, forged coupler.	Bulk
SPB50 0300	Bottom support plate with 2.29" diameter hole, cast and stamped couplers.	Bulk
SPBQ500300	Bottom support plate with 2.3" square hole	Bulk



FP20000201



500244

REMOVABLE FOOTPLATES

Part No.	Description	Pkg.
REMOVABLE FOOTPLATES		
0185640301	Removable footplate w/pin. 2.1" tall, fits 2" inner tube, 2,000-5,000 lbs. rated	Bulk
018098	Removable footplate w/pin. 6.2" tall, fits 2" inner tube, 2,000-5,000 lbs. rated	Bulk
FP20000201	Foot with hardware (bolt goes through 2" jack tube holes) – 2,000 lbs. rated	Poly Bag
500244	Removable footplate with pin. Fits Jacks with 2" inner tube. (2.1" tall)	Clam



DF35000324



500190

DROP LEGS

Part No.	Description	Pkg.
DROP LEGS		
DF35000324	For square jack, 1.71" square tube, pin included – 3,000 - 5,000 lbs. rated	Bulk
500270	For square jack, 2.0" square tube, pin included – 8,000 lb. rated	Bulk
701292-01	For square jack, 2.25" square tube, pin not included - 10,000 lb. rated	Bulk
500190	For round jacks with 2.0" inner tubes, pin included - 5,000 lbs. rated	Ind. Box



500103



500177

PINS

Part No.	Description	Pkg.
PINS		
500103	3/8" plunger pin assembly. (Bulldog only)	Poly Bag
700377	3/4" pull pin (4.75" long) with chain without drive screw – 7,000 lbs.	Bulk
701029	7/8" pull pin (5.12" long) with chain without drive screw – 12,000 lbs.	Bulk

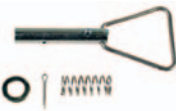

500178



500243

PIN KITS

500178	1/2" plunger pin assembly kit. SERIES: 150, 160, 170	Clam
500243	9/16" pull pin 3.5" long with chain and drive screw. (5,000 lbs. - Topwind only) SERIES: 150, Topwind-170	Clam
500231	5/8" pull pin 3.5" long, with chain, and drive screw. (5,000 lbs. - Sidewind only) SERIES: Sidewind-170, Crown® 2,000/3,000/5,000 lbs.	Clam
500232	5/8" pull pin, 4.25" long, with chain, and cotter pin. SERIES: 190, Crown® 7,000 lbs.	Clam
500177	3/4" drop-leg plunger pin kit SERIES: 180	

DROP LEG PINS

701472	9/16" drop leg pin, with chain and lynch pin for 190 series square jacks	Bulk
701471	3/4" drop leg pin, with chain and lynch pin for 180 series square jacks	Bulk

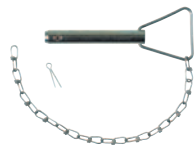

500232



500231



500239



500238



500240



500242



500148



800075



500180

MOUNTS

Part No.	Description	Pkg.
MOUNTS		
500239	Trailer mount, male, weld-on, for 9/16" pin. (5,000 lbs. - Topwind only) SERIES: 150, Topwind-170	Clam
500238	Trailer mount, female, weld-on, for 5/8" pin, 3" O.D.	Clam
500240	Trailer mount, male, weld-on, for 5/8" pin, 2" O.D.	Clam
RETAINING RING MOUNTING BRACKETS		
P20520-00	Weld-on flat, retaining ring swivel plate for 3/8" diameter plunger pin.	Bulk
P9222-00	Weld-on, swivel bracket, 1/2" pin – 2,000 - 5,000 lbs. rated	Bulk
500242	Weld-on, swivel bracket, 1/2" pin – 2,000 - 5,000 lbs. rated	Clam

TOPWIND CRANKS

Part No.	Description	Pkg.
TOPWIND CRANKS		
500180	Topwind crank (6.75" radius) assembly with red knob. SERIES: Topwind-150, 160, 170. 2,000 - 5,000 lbs.	Clam
500148	Topwind crank (9.00" radius) assembly with black knob. SERIES: Topwind-190 7,000 lbs. 7,000 / 8,000 lbs.	Clam
800075	Topwind crank 1" tubing (15.50" radius) - 12,000 lb. square	Bulk

SIDEWIND CRANKS

Part No.	Description	Pkg.
SIDEWIND CRANKS		
500256	Sidewind crank (5.80" radius) assembly and gear kit. SERIES: 150 with plastic cap. 2000 lbs.	Clam
500105	Sidewind crank (6.50" radius) assembly with black knob. SERIES: 139, 159, 170, Crown® 2,000/3,000/5,000 lbs.	Clam
500171	Sidewind crank (8.50" radius) assembly with black knob. SERIES: 190 square jacks, Crown® 7,000 lbs. 7,000 / 8,000 lbs.	Clam
015181	Sidewind crank, vertical clevis (13.50" radius), black primed finish, hardware included	Bulk
800102	Sidewind crank assembly with 13.50" radius. Mounting hardware not included. Extends 17.50" from the jack. Black primed finish. Horizontal clevis, Sidewind handle.	Bulk
701466	Removable sidewind crank with 13.5" offset radius. All zinc-plated crank. Dual handle grips for cranking and shifting. For use with OEM supplied outboard bushing or may be attached directly on jack gearbox.	Bulk
800090	Sidewind crank, horizontal clevis (13.50" radius), black primed finish, hardware included	Bulk
8001090283	Sidewind crank assembly with 13.50" radius, mounting hardware not included, extends 20" from the jack, black prime finish, vertical clevis	Bulk



500256



500105

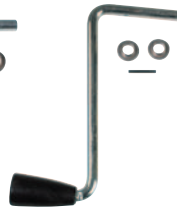

500171



701466



500106



500156

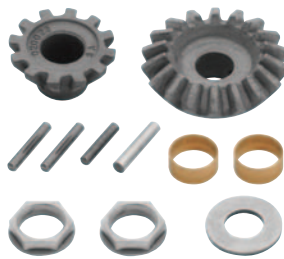

500212



500251

ASSEMBLY KITS

Part No.	Description	Pkg.
BEARING KITS		
500251	Bearing kit. For 2,000 lb. capacity models. SERIES: 150	Clam
500223	Thrust bearing. For 5,000 lb. capacity models. SERIES: 170, Crown® 5,000 lbs.	Clam
500224	Thrust bearing. For 8,000 lb. capacity models. SERIES: 190, Crown® 7,000 lbs.	Clam
GEAR KITS		
500106	Sidewind gear kit. For up to and including 5,000 lb. capacity models. SERIES: 139, 159, 170 Crown® 2,000/3,000/5,000 lbs.	Clam
500156	Sidewind gear kit. For 8,000 lb. capacity models. SERIES: 190, Crown® 7,000 lbs. with 1/2" inside bottom gear	Clam
5002581360	Sidewind gear kit. SERIES: 190 Crown® 7,000 lbs. with 5/8" I.D. bottom gear	Poly Bag
800144	Service kit containing the sidewind crank (10.50"), bearing, gears, pins and bushings for 10,000 lbs. capacity 180 SERIES sidewind jacks	Poly Bag
500285	Sun gear and stub shaft assembly and bushings for 12,000 lb. capacity two speed planetary gear box	Poly Bag
500212	Gear kit including, pins and bushing – 12,000 lbs.	Poly Bag
RETAINING RING KITS		
500241	Swivel retaining ring. Fits most jack capacities. SERIES: 150, 160, 170	Clam
P9086-00	Swivel retaining ring. Fits most jack capacities. SERIES: 150, 160, 170	Bulk
ASSEMBLY KIT		
500217	Screw and nut assembly, bearing, support washer and retaining pins for 12,000 lb. capacity BULLDOG® sidewind jacks	Poly Bag
500250	Screw and nut assembly, bearing, support washer and retaining pins for 12,000 lb. capacity BULLDOG® topwind jacks	Poly Bag
GEAR BOX COVER		
500205	Gear box cover for 3,000 - 8,000 lb. capacity sidewind jacks, includes hardware	Poly Bag



500223



500224



500241



500248



500246

KNOBS

Part No.	Description	Pkg.
KNOBS		
500248	Black knob, teardrop. SERIES: 139, 159, Sidewind-170, 90, Crown®. 2,000 - 5,000 lbs.	Clam
500246	Red knob, BULLDOG. SERIES: 150, 160, Topwind-170. 2,000 - 5,000 lbs.	Clam



F2® MARINE AND RECREATIONAL JACKS **FULTON**

Fulton, the industry leader for high performance marine jacks, is proud to introduce a revolution in trailer jack engineering. The F2®, designed for use with marine, recreational and utility trailers, continues the Fulton heritage of innovation rethinking every feature and challenging industry conventions. The result is a reengineered high quality product that will transform the industry. It's so strong and reliable that Fulton is backing it with an unprecedented LIMITED LIFETIME WARRANTY.

- Maintenance free - designed to eliminate the need for lubrication and maintenance
- Corrosion resistant coatings cover internal and external components - will hold up in harsh environments
- Ergonomic design - crank, release pin and integrated wheel wedge are made of strong, engineered plastic for a comfortable touch
- Stylish design - compliment your boat and customize your trailer's styling
- Sealed and lubricated one-piece gearbox
- Twin track and wide track versions available
- Available in bolt-on and weld-on versions for up to 5" tongues
- Handle Hold-Up secures handle to jack tube when in stowed position
- Limited Lifetime Warranty

F2® MARINE AND RECREATIONAL JACKS - TWIN TRACK MODELS

Part No.	Lift Cap. (lbs.)	Handle Style	Screw Travel	Mount Travel	Pull Pin Diameter	Description	Packaging
1413020134	1,600	Sidewind	10"	8"	9/16"	Individually Boxed. Includes Handle Hold-Up & Wheel Wedge Features, & Bolt-On Mounting Hardware for 3"x3" & 3"x4" Frames.	Ind. Box
1413060334	1,600	Sidewind	10"	8"	9/16"	3"x4" Pivot Housing. Includes Handle Hold-Up Feature & Weld-On Mounting Bracket & Hardware.	Bulk
1413080334	1,600	Sidewind	10"	8"	9/16"	Includes Handle Hold-Up Feature & Bolt-On Mounting Hardware for 3"x4" Frame.	Bulk
1413120334	1,600	Sidewind	10"	8"	9/16"	4"x5" Pivot Housing. Includes Handle Hold-Up Feature & Weld-On Mounting Bracket & Hardware.	Bulk
1413130334	1,600	Sidewind	10"	8"	9/16"	4"x5" Pivot Housing. Includes Handle Hold-Up Feature & Bolt-On Mounting Hardware for 3"x5" Frame.	Bulk

F2® MARINE AND RECREATIONAL JACKS - WIDE TRACK MODELS

Part No.	Lift Cap. (lbs.)	Handle Style	Screw Travel	Mount Travel	Pull Pin Diameter	Description	Packaging
1413040134	1,600	Sidewind	10"	8"	9/16"	Individually Boxed. Includes Handle Hold-Up & Wheel Wedge Features, & Bolt-On Mounting Hardware for 3"x3" & 3"x4" Frames.	Ind. Box
1413050334	1,600	Sidewind	10"	8"	9/16"	3"x4" Pivot Housing. Includes Handle Hold-Up Feature & Weld-On Mounting Bracket & Hardware.	Bulk
1413110334	1,600	Sidewind	10"	8"	9/16"	4"x5" Pivot Housing. Includes Handle Hold-Up Feature & Weld-On Mounting Bracket & Hardware.	Bulk
1413140334	1,600	Sidewind	10"	8"	9/16"	4"x5" Pivot Housing. Includes Handle Hold-Up Feature & Bolt-On Mounting Hardware for 3"x5" Frame.	Bulk

Accessories / Replacement Parts

Part No.	Description	Packaging
500130	TWIN TRACK WHEEL REPLACEMENT KIT. Includes (2) wheels & all necessary mounting hardware to mount (2) wheels.	Bagged
500131	WIDE TRACK WHEEL REPLACEMENT KIT. Includes (1) wheel & all necessary mounting hardware to mount (1) wheel.	Bagged
500132	TWIN TRACK WHEEL WEDGE KIT. Includes mounting hardware.	Bagged
500133	WIDE TRACK WHEEL WEDGE KIT. Includes mounting hardware.	Bagged
500134	F2® HANDLE/CRANK KIT. Includes handle grip, groove pin & all necessary mounting hardware.	Bagged
500135	GEARBOX COVER REPLACEMENT KIT. Includes (4) mounting screws.	Bagged
500136	PULL PIN REPLACEMENT KIT. Includes spring & retaining ring.	Bagged
500137	BEARING REPLACEMENT KIT. Includes (2) washers.	Bagged
500138	(1) TWIN TRACK WHEEL ONLY	Bagged
500277	Weld-On Mounting Bracket & Hardware for 3"x4" Pivot Housing.	Bagged

NOTE: Contact Cequent Customer Service for package quantities.
Twin Wheel US Patent D568,575 and Wide Wheel US Patent D570,072 and Handle US Patent D577,175



5" Frame Model

1413230134

F2® MARINE AND RECREATIONAL JACKS

Fulton, the industry leader for high performance jacks, is proud to introduce another addition to the F2® family of trailer jacks. Our 2,000 lb. lift capacity adjustable swivel with footplate jacks pack all of the features of the award winning Twin Track & Wide Track models, along with the unprecedented LIMITED LIFETIME WARRANTY. The 2,000 lb. capacity jacks possess the following unique features.

- Heavy duty articulating footplate - 7" diameter cast footplate provides superior stability. Unique ball and socket connection between jack and footplate allows for whatever articulation is required to accommodate uneven surfaces
- 13" of swivel mount height adjustment
- Available in bolt-on versions for 4" and 5" frames and weld-on versions for up to 5" frames
- Handle Hold-Up secures handle to jack tube when in stowed position
- Limited Lifetime Warranty

F2® MARINE AND RECREATIONAL JACKS - ADJUSTABLE SWIVEL WITH FOOTPLATE

Part No.	Lift Cap. (lbs.)	Handle Style	Screw Travel	Mount Travel	Pull Pin Diameter	Description	Packaging
1413200334	2,000	Sidewind	10"	13"	9/16"	Includes Handle Hold-Up Feature & Weld-On Mounting Bracket & Hardware for up to 5" Frames.	Bulk
1413210334	2,000	Sidewind	10"	13"	9/16"	Includes Handle Hold-Up Feature & Bolt-On Mounting Hardware for 3"x4" Frame.	Bulk
1413220334	2,000	Sidewind	10"	13"	9/16"	Includes Handle Hold-Up Feature & Bolt-On Mounting Hardware for 3"x5" Frame.	Bulk
1413230134	2,000	Sidewind	10"	13"	9/16"	Includes Handle Hold-Up Feature & Bolt-On Mounting Hardware for 3"x4" and 3"x5" Frames.	Ind. Box

Accessories / Replacement Parts

Part No.	Description	Packaging
500134	F2® HANDLE/CRANK KIT. Includes handle grip, groove pin & all necessary mounting hardware.	Bagged
500135	GEARBOX COVER REPLACEMENT KIT. Includes (4) mounting screws.	Bagged
500136	PULL PIN REPLACEMENT KIT. Includes spring & retaining ring.	Bagged
500137	BEARING REPLACEMENT KIT. Includes (2) washers.	Bagged



F2® A-FRAME JACK AND COUPLER COMBINATION

Fulton expands the F2® family of trailer jacks with the adjustable height A-Frame jack and coupler combination. In addition to all the features of the award winning F2® jacks these models include the following unique features.

- F2® Coupler, Class 4, with special cutout mounting area to accept jack
- Versatile handle orientation mounting options: front, driver side or passenger side facing
- 2,000 lb. lift capacity
- Removable foot/wheel options (purchase separately):
 7" round articulating footplate (2,000 lb. lift capacity)
 7" diameter twin track wheel (1,600 lb. lift capacity)
 8" diameter wide track wheel (1,600 lb. lift capacity)
- Limited Lifetime Warranty



1413250334



44305F0317

F2® A-FRAME JACK AND COUPLER COMBINATION

Part No.	Lift Cap. (lbs.)	Handle Style	Screw Travel	Description	Packaging
1413250334	2,000	Sidewind	9"	Adjustable Height A-Frame Jack. NOTE: Requires F2 Coupler	Bulk
44305F0317	—	—	—	Coupler, Class 4, 2-5/16" Ball, 10,000 lb. Capacity Coupler	Bulk

F2® A-FRAME JACK AND COUPLER COMBINATION - REMOVABLE FOOT/WHEEL OPTIONS

Part No.	Lift Cap. (lbs.)	Description	Packaging
500265	1,600	7" Twin Track Wheels, Includes Pull Pin Assembly	Bulk
500266	1,600	8" Wide Track Wheel, Includes Pull Pin Assembly	Bulk
500267	2,000	7" Round Articulating Footplate, Includes Pull Pin Assembly	Bulk

Twin Wheel US Patent D568,575 and Wide Wheel US Patent D570,072 and Handle US Patent D577,175



500265



500266



500267



MARINE AND RECREATIONAL JACKS

- Designed for use with marine and utility trailers
- Includes all necessary mounting hardware



EJ1000

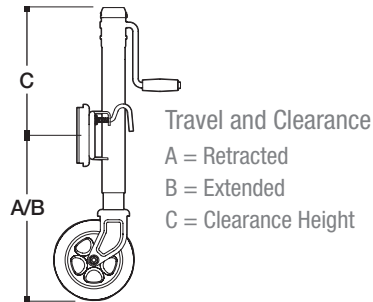

MARINE AND RECREATIONAL JACKS - RETAINING RING SWIVEL

Part No.	Lift Capacity (lbs.)	Handle Style	Travel	Measurements			Description	Lbs.	Pkg.
				A Retracted	B Extended	C Clearance			
EJ10000101	1,000	Sidewind	10"	13.0"	23.0"	11.0"	6" Wheel, Clear Zinc Finish, Bolt-on, Fits up to 3"x5" Trailer Frame	15.0	Ind. Box
EJ10000301	1,000	Sidewind	10"	13.0"	23.0"	11.0"	6" Wheel, Clear Zinc Finish, Bolt-on, Fits up to 3"x5" Trailer Frame	15.0	Bulk



MARINE AND RECREATIONAL JACKS

Designed for use with marine and utility trailers, Fulton brand tongue jacks are time- tested and application-proven. Our bolt-on versions include all necessary mounting hardware. For weld-on applications, we offer two styles of mounts for both 1/2" and 3/8" pull pin models. The Fulton brand bolt-thru swivel mounts (U.S. PAT. 6,302,381) use 3-D formed heavy-gauge steel stampings and a proprietary bushing material for a mount with minimal deflection and maximum support. All mounts fit up to a 3" x 5" trailer frame.

- Extensive choice of popular models, Sidewind Crank with Round or Square Tubes
- Strong proprietary bushing materials
- Stable formed heavy-gauge steel construction
- Dependable design
- Lift capacity from 400 lbs. to 5,000 lbs.

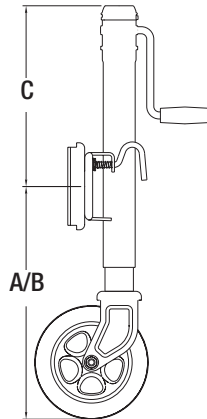

- 600 hour salt spray rating per ASTM B117

Travel and Clearance Diagram

- A= Retracted
- B= Extended
- C= Clearance Height

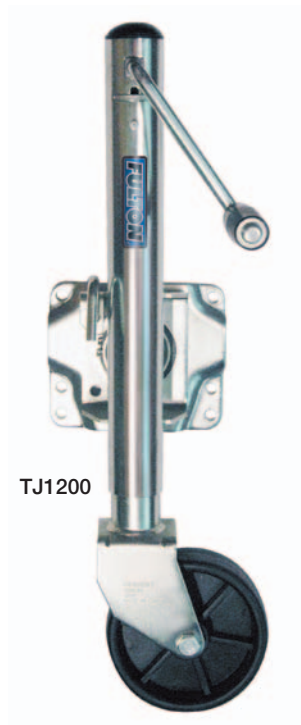



MARINE AND RECREATIONAL JACKS - PATENTED BOLT-THRU SWIVEL

Part No.	Lift Capacity (lbs.)	Handle Style	Travel	Measurements			Description	Finish	Pull Pin Dia.	Pkg.
				A Retracted	B Extended	C Clearance				
XP10 0101	1,200	Sidewind	10"	12.5"	22.5"	10.5"	6" Diameter Wheel, Bolt-On , Mounting Hardware for up to 5" Frame Included, Handle & Wheel Unassembled	Z-Max 600 Clear Zinc	1/2"	Ind. Box
XP10 0301	1,200	Sidewind	10"	12.5"	22.5"	10.5"	6" Diameter Wheel, Bolt-On , Mounting Hardware for up to 5" Frame Included	Z-Max 600 Clear Zinc	1/2"	Bulk
XP10W 0301	1,200	Sidewind	10"	12.5"	22.5"	10.5"	6" Diameter Wheel, Weld-On, P9012-00 Weld-On Mount & Hardware SOLD SEPARATELY	Z-Max 600 Clear Zinc	1/2"	Bulk
XP100W0301	1,200	Sidewind	10"	14.8"	24.8"	10.5"	8" Diameter Spoked Wheel, Weld-On, P9012-00 Weld-On Mount & Hardware SOLD SEPARATELY	Z-Max 600 Clear Zinc	1/2"	Bulk
XP10WC0301	1,200	Sidewind	10"	12.9"	22.9"	10.5"	Improved Castering Performance - Yoke/Wheel Swivel Independent of Inner Tube, 6" Diameter Wheel, Weld-On, P9012-00 Weld-On Mount & Hardware SOLD SEPARATELY	Z-Max 600 Clear Zinc	1/2"	Bulk
XP15 0101	1,500	Sidewind	10"	13.0"	23.0"	12.4"	8" Diameter Spoked Wheel, Bolt-On , Mounting Hardware for up to 5" Frame Included, Handle & Wheel Unassembled	Z-Max 600 Clear Zinc	1/2"	Ind. Box
XP15 0301	1,500	Sidewind	10"	13.0"	23.0"	12.4"	8" Diameter Spoked Wheel, Bolt-On , Mounting Hardware for up to 5" Frame Included	Z-Max 600 Clear Zinc	1/2"	Bulk
XP15W 0301	1,500	Sidewind	10"	13.0"	23.0"	12.4"	8" Diameter Spoked Wheel, Weld-On, P9012-00 Weld-On Mount & Hardware SOLD SEPARATELY	Z-Max 600 Clear Zinc	1/2"	Bulk
XP15WC0301	1,500	Sidewind	10"	13.6"	23.6"	12.4"	Improved Castering Performance - Yoke/Wheel Swivel Independent of Inner Tube, 8" Diameter Spoked Wheel, Weld-On, P9012-00 Weld-On Mount & Hardware SOLD SEPARATELY	Z-Max 600 Clear Zinc	1/2"	Bulk
1411300301	1,500	Sidewind	10"	15.6"	25.6"	10.4"	Ideal for Torsion Axle Trailers - Mount 2" Higher, Improved Castering Performance - Yoke/Wheel Swivel Independent of Inner Tube, 8" Diameter Spoked Wheel, Weld-On, P9012-00 Weld-On Mount & Hardware SOLD SEPARATELY	Z-Max 600 Clear Zinc	1/2"	Bulk
XP15L 0101	1,500	Sidewind	12"	13.0"	25.0"	14.4"	Additional 2" of Travel, 8" Diameter Spoked Wheel, Bolt-On , Mounting Hardware for up to 5" Frame Included, Handle & Wheel Unassembled	Z-Max 600 Clear Zinc	1/2"	Ind. Box
XP15L 0301	1,500	Sidewind	12"	13.0"	25.0"	14.4"	Additional 2" of Travel, 8" Diameter Spoked Wheel, Bolt-On , Mounting Hardware for up to 5" Frame Included	Z-Max 600 Clear Zinc	1/2"	Bulk
XPD15L0101	1,500	Sidewind	12"	13.1"	25.1"	12.4"	Dual Wheel , Additional 2" of Travel, 6" Diameter Wheels, Bolt-On , Mounting Hardware for up to 5" Frame Included, Handle & Wheel Unassembled	Z-Max 600 Clear Zinc	1/2"	Ind. Box
XPD15L0301	1,500	Sidewind	12"	13.1"	25.1"	12.4"	Dual Wheel , Additional 2" of Travel, 6" Diameter Wheels, Bolt-On , Mounting Hardware for up to 5" Frame Included	Z-Max 600 Clear Zinc	1/2"	Bulk

MARINE AND RECREATIONAL JACKS - RETAINING RING SWIVEL

Part No.	Lift Capacity (lbs.)	Handle Style	Travel	Measurements			Description	Finish	Pull Pin Dia.	Pkg.
				A Retracted	B Extended	C Clearance				
1410050149	400	N/A	N/A	14.5"	N/A	4.5"	Swiveling Trailer Stand, 6" Diameter Wheel, Bolt-On , Mounting Hardware for up to 5" Frame Included, Wheel Unassembled	Silver Powder Coat	3/8"	Ind. Box
TJ12000101	1,200	Sidewind	10"	12.7"	22.7"	11.4"	6" Diameter Wheel, Bolt-On , Mounting Hardware for up to 5" Frame Included, Handle & Wheel Unassembled	Z-Max 600 Clear Zinc	3/8"	Ind. Box
TJ12000301	1,200	Sidewind	10"	12.7"	22.7"	11.4"	6" Diameter Wheel, Bolt-On , Mounting Hardware for up to 5" Frame Included	Z-Max 600 Clear Zinc	3/8"	Bulk
TJ120W0301	1,200	Sidewind	10"	12.7"	22.7"	11.4"	6" Diameter Wheel, Weld-On , Mount & Retaining Ring Included, Both Shipped Loose/Unassembled	Z-Max 600 Clear Zinc	3/8"	Bulk



MARINE AND RECREATIONAL JACKS - FIXED MOUNT

Part No.	Lift Capacity (lbs.)	Handle Style	Travel	Measurements			Description	Finish	Pkg.
				A	B	C			
TJ12220301	1,200	Sidewind	15"	9.3"	24.3"	19.5"	6" Diameter Wheel, Bolt-On , Mounting Hardware for up to 5" Frame Included	Z-Max 600 Clear Zinc	Bulk
HD25000101	2,500	Sidewind	28"	7.00"	35.5"	19.25"	Heavy Duty Square, Drop Leg Jack , 3.8" x 7.5" Footplate, Bolt-On , Mounting Hardware for up to 5" Frame Included, Handle Unassembled, Travel Includes Drop Leg	Z-Max 600 Clear Zinc	Ind. Box
35SM28FZ	2,500	Sidewind	28"	7.00"	35.5"	19.25"	Heavy Duty Square, Drop Leg Jack , 3.8" x 7.5" Footplate, Bolt-On , Mounting Hardware for up to 5" Frame Included, Travel Includes Drop Leg	Z-Max 600 Clear Zinc	Bulk
HD50000101	5,000	Sidewind	28"	6.5"	35.0"	18.5"	Heavy Duty Square, Drop Leg Jack , 6.0" x 8.0" Footplate, Bolt-On , Mounting Hardware for 4", 5", & 6" High Frames Included, Travel Includes Drop Leg	Z-Max 600 Clear Zinc	Ind. Box
HD50000301	5,000	Sidewind	28"	6.5"	35.0"	18.5"	Heavy Duty Square, Drop Leg Jack , 6.0" x 8.0" Footplate, Bolt-On , Mounting Hardware for 5" High Frame Included, Travel Includes Drop Leg	Z-Max 600 Clear Zinc	Bulk

ACCESSORIES - MARINE AND RECREATIONAL JACKS

MOUNTING KIT

Part No.	Description
P9012-00	Weld-On Mounting Kit, for XP Series Jacks
500286	Bolt-On Mounting Hardware Kit
0933325S00	Mounting Hardware & Bushing for XP Bolt-Thru Swivel Mount

PARTS - MARINE AND RECREATIONAL JACKS

HANDLE KIT

Part No.	Description / Application
0933301S00	Includes (1) Handle Assembly with Plastic Handle Roller, (1) Groove Pin, & (1) Flanged Bushing TJ503/C, TJU503, PMJ53, TJ507/C, PMJ75, CS750, GR700/TJ712 , XP10/L/W/WC, XP100
0933305S00	Includes (1) Handle Assembly with Plastic Handle Roller, (1) Groove Pin, & (1) Flanged Bushing TJ1055, TJ1057, TJ1222, TJ255, TJD125, TJ122F , XP15/L/W/WC, XP15L, HD2500

BEVEL GEAR KIT

Part No.	Description / Application
0933302S00	Includes (2) Gears, (1) Groove Pin, (1) Pin, (1) Washer, & (1) Flanged Bushing TJ503 , XP10 (all 1,200 lbs. capacity)
0933306S00	Includes (2) Gears, (1) Groove Pin, (1) Pin, (1) Washer, (1) Spacer, & (2) Flanged Bushings TJ1055, TJ1057, TJ1222, TJ1255, TJD125, TJ122F , XP15/L/W/WC, XPF15L, HD2500

PLUNGER PIN KIT

Part No.	Description / Application
0933307S00	Includes (1) ½" Plunger Pin, (1) Plunger Pin Cap, (1) Washer, (1) Cotter Pin, & (1) Spring TJ1055, TJ1057, TJ1255, TJD125, TJ122F , XP15/L/W/WC, XPF15L XP10 (all 1,200 lb. capacity)

WHEEL REPAIR KIT

Part No.	Application
6811S00	All 6" models including TJ600T (excluding TJD125, TJD103)

SNAP RING

Part No.	Application
P9086-00	All models

CAP

Part No.	Application
0917540-00	Cap, Dome - 2" Jack Tube w/1 Tab, 1 Zerk
0917514-00	Cap, Dome - 2-1/4" Jack Tube w/1 Screw, 1 Zerk

NOTE: RED part numbers indicate discontinued items.

MULTI-JACK

A versatile tool for lifting, pulling, clamping, and spreading, the BULLDOG 48" Multi-Jack is always handy to have along on 4x4s and other off-road vehicles. You'll really appreciate its power when it makes backbreaking jobs like tearing out stumps and pulling up posts a breeze.

- ALL-STEEL CONSTRUCTION - Provides reliable strength
- RUGGED RATCHET DESIGN - Holds up to time and heavy use
- 36" STEEL HANDLE - Multiplies effort while keeping the operator clear
- LARGE 10" X 10" BASE - Increases ground contact surface area
- 35" OF TRAVEL - Lets you lift loads from 5" to 40" with ease
- SIMPLE DESIGN - Packs power into 30 lbs. of multipurpose equipment

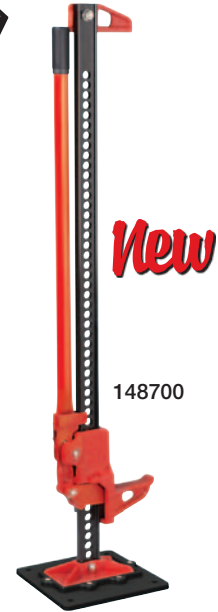

MULTI-JACK

Part No.	Capacity	Travel	Extended	Description	Pkg.	Unit Wt. Lbs.
148700	Tested to 7,000 lbs. (4,660 lbs. maximum rated load at 48")	35"	48"	Multipurpose Jack	Ind. Pack	30.0

STABILIZERS

Square tube stabilizers are fabricated from high strength, structural steel tubing, and are yellow zinc-plated for excellent corrosion-resistance. Common applications include cargo trailers, industrial implements, and equipment outriggers.

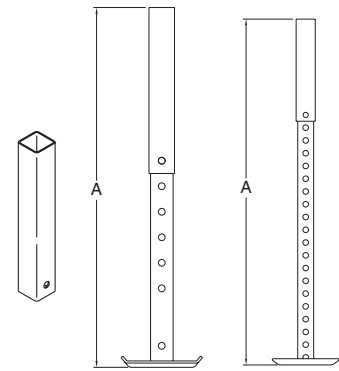
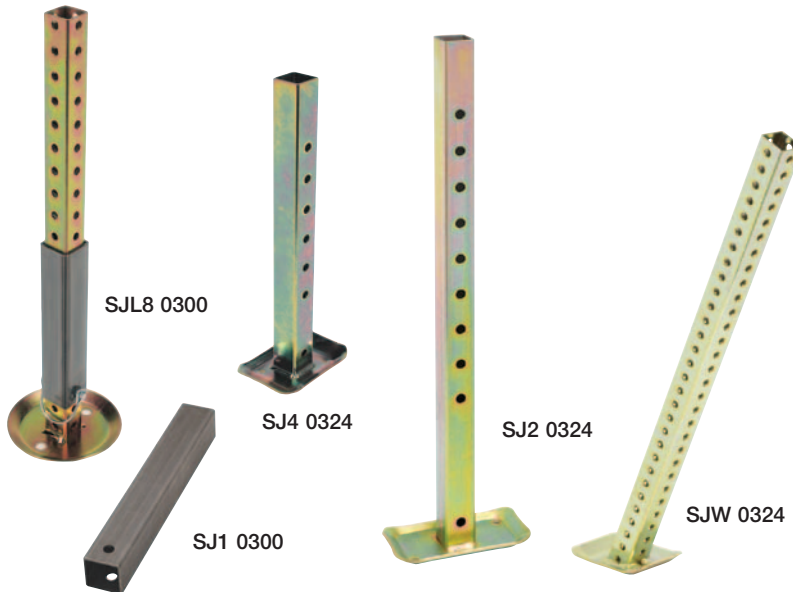

Travel and Clearance Diagram
A= Range

STABILIZERS

Part No.	Static Capacity (lbs.)	Adjustment Range (A)	Overall Length Dimension	Description	Pkg.
STABILIZER - KIT					
SJL8 0300	2,000	8" - 27"	20" drop leg, 8" outer	Assembly drop leg and 1-1/2" outer tube (includes pin)	Bulk
STABILIZER - TUBE AND DROP LEGS					
SJ1 0300	3,000	N/A	13"	2" square outer tube, oil finish (pin not included)	Bulk
SJ2 0324	3,000	25" - 37"	28.75"	Square drop leg with adjustment holes (pin not included)	Bulk
SJ4 0324	3,000	18" - 28"	20"	Square drop leg with adjustment holes (pin not included)	Bulk
STABILIZER - DROP LEG					
SJW 0324	3,000	Up to 24"	30.5"	Square drop leg with adjustment holes, foot at 30 degree angle to tube. NOTE: Will not work with SJ1 0300 tube.	Bulk



028499



HEAVY DUTY COUPLERS

Designed for utility, horse/livestock, cargo, and construction trailer applications, BULLDOG Collar-Lok™ are the strongest in the industry. The BULLDOG design features the only automatic and continuously tight ball fit in the industry. A variety of coupler styles, tongue mounts, and latches allow configurations to match virtually any trailer. Adjustable couplers assure level operation for trailers when pulled by a variety of different vehicles.

- Easiest to use.
- Strong in both static and dynamic loading conditions.
- Hinged ball socket for easy hook up.
- Clear, visual indication of proper closure.





028655



028630





COLLAR-LOK™ COUPLERS - TONGUE MOUNTS

	No. 2 Tongue Mount 2-1/4" outside diameter x 1-3/4" inside diameter steel tubing.
	No. 4 Tongue Mount High-strength steel for 3" square or rectangular trailer tongue (bolt holes optional).
	No. 5 Tongue Mount High-strength steel for 3-1/2" OD round trailer tongue.
	No. 6 Channel Mount Fits inside 2-7/8" wide channel.
	No. 8 Tongue Mount High-strength steel for 50-degree trailer tongue (tapped mounting holes optional for A-frame style jacks).

COLLAR-LOK™ COUPLERS - "B" STYLE COUPLERS

	2B Style 5,000 lbs. gross trailer weight for 2" ball.
	3B Style 7,000 lbs. gross trailer weight for 2" ball.
	4B Style 12,500 lbs. gross trailer weight for 2-5/16" ball.
	5B Style 15,000 lbs. gross trailer weight for 2-5/16" ball.

COLLAR-LOK™ COUPLERS - LATCHES

	L - Low Profile (No. 8 Tongue Mount only)
	H - High Profile
	M - Pin Only



HEAVY DUTY COUPLERS - COLLAR-LOK™ COUPLERS

Part No.	Model No.	Gross Trailer Weight	Overall Length	Latches	Ball Size	SAE Class	Coupler Style	Description	Unit Weight Lbs.
NO. 2 ROUND TUBULAR TONGUE MOUNT									
028381	2B2H	5,000	10-3/4"	High Profile	2"	III	2B Style	2-1/4" OD x 1-3/4" ID, steel tubing	8.0
028242	2B2M	5,000	10-3/4"	Pin Style	2"	III	2B Style	2-1/4" OD x 1-3/4" ID, steel tubing	8.0
028461	4B2H	12,500	12-3/4"	High Profile	2-5/16"	N/A	4B Style	2-1/4" OD x 1-3/4" ID, steel tubing	8.0
028442	4B2M	12,500	12-3/4"	Pin Style	2-5/16"	N/A	4B Style	2-1/4" OD x 1-3/4" ID, steel tubing	8.0
NO. 4 3" SQUARE/RECTANGULAR TONGUE MOUNT									
028382 ♦	2B4H	5,000	16-1/4"	High Profile	2"	III	2B Style	High-strength steel for 3" square or rectangular trailer tongue	10.5
028244	2B4M	5,000	16-1/4"	Pin Style	2"	III	2B Style	High-strength steel for 3" square or rectangular trailer tongue	10.5
028387 ♦	3B4H	7,000	16-1/4"	High Profile	2"	IV	3B Style	High-strength steel for 3" square or rectangular trailer tongue	11.5
028243	3B4M	7,000	16-1/4"	Pin Style	2"	IV	3B Style	High-strength steel for 3" square or rectangular trailer tongue	11.5
028462 ♦	4B4H	12,500	16-1/2"	High Profile	2-5/16"	N/A	4B Style	High-strength steel for 3" square or rectangular trailer tongue	12.0
028444	4B4M	12,500	16-1/2"	Pin Style	2-5/16"	N/A	4B Style	High-strength steel for 3" square or rectangular trailer tongue	12.0
NO. 5 3" ROUND STRAIGHT TONGUE MOUNT									
028383	2B5H	5,000	16-1/4"	High Profile	2"	III	2B Style	High-strength steel for 3-1/2" OD round trailer tongue	10.5
NO. 6 ADJUSTABLE CHANNEL MOUNT									
028390 ♦	3B6M	7,000	9.5"	Pin Style	2"	IV	3B Style	Fits inside 3" wide channel	10.0
028630 ♦	4B6M	12,500	10"	Pin Style	2-5/16"	N/A	4B Style	Fits inside 3" wide channel	9.0
NO. 8 A-FRAME TONGUE MOUNT									
028384	2B8H	5,000	16"	High Profile	2"	III	2B Style	High-strength steel for 50° trailer tongue	12.0
028288 ♦	2B8L	5,000	16"	Low Profile	2"	III	2B Style	High-strength steel for 50° trailer tongue	12.0
028386	3B8H	7,000	16"	High Profile	2"	IV	3B Style	High-strength steel for 50° trailer tongue	13.0
028287 ♦	3B8L	7,000	16"	Low Profile	2"	IV	3B Style	High-strength steel for 50° trailer tongue	13.0
028463	4B8H	12,500	16-1/2"	High Profile	2-5/16"	N/A	4B Style	High-strength steel for 50° trailer tongue	14.0
028499 ♦	4B8L	12,500	16-1/2"	Low Profile	2-5/16"	N/A	4B Style	High-strength steel for 50° trailer tongue	14.0
028656	5B8H	15,000	16-1/2"	High Profile	2-5/16"	N/A	5B Style	Black primed finish	16.0
028655	5B8L	15,000	16-1/2"	Low Profile	2-5/16"	N/A	5B Style	Black primed finish	16.0
REPLACEMENT PART - COLLAR-LOK™ COUPLER KIT									
024200	N/A	N/A	N/A	High Profile	N/A	N/A	N/A	Kit includes high profile latch handle, latch wire, latch pin, push nut, and cotter pin.	N/A

NOTE: Other custom-made designs are available upon request. ♦ DENOTES MOST POPULAR

⚠ WARNING

Failure to close coupler securely before towing or failure to use with specified ball size may result in serious injury or death.



44150W

CAST COUPLERS

Designed for utility, horse/livestock, cargo, and construction trailer applications, BULLDOG Couplers are the strongest in the industry. The patented cast head "Wedge-Latch" coupler design is offered in heavy-duty, A-frame, and convenient adjustable height models. Adjustable couplers assure level operation for trailers when pulled by a variety of different vehicles. The replaceable latching hardware allows for longer service life.

- Quick and easy to engage
- Strong and secure on the road
- Patented Wedge-Latch® ball clamp design
- Quick to hook up and disconnect
- In compliance with SAE standard J684



Wedge-Latch® A-Frame Mount, Patent Pending, Cast A-frame couplers with patented replaceable hardware for longer service life



Wedge-Latch® Flat Plate Mount



Wedge-Latch® Adjustable Height Coupler
US Patent 6,505,849



Adjustable Height Bracket

HEAVY DUTY COUPLERS - CAST COUPLERS

Part No.	Gross Trailer Weight	Overall Length	Latches	Ball Size	SAE Class	Description	Unit Weight Lbs.
WEDGE-LATCH® CAST HEAD COUPLERS							
43805W0317	8,000	18"	Wedge Latch	2"	IV	Round jack mount, 50° A-frame	14.3
44125W0317	12,500	18"	Wedge Latch	2-5/16"	IV	Round jack mount, 50° A-frame	18.6
44150W0317	15,000	18"	Wedge Latch	2-5/16"	IV	Round jack mount, 50° A-frame	18.6
44150WQ317	15,000	18"	Wedge Latch	2-5/16"	IV	Square jack mount, 50° A-frame	18.6
44150WH301	15,000	18"	Wedge Latch	2-5/16"	IV	Round jack mount, 50° A-frame, for bolt-on applications	18.6
WEDGE-LATCH® FLAT MOUNT CAST HEAD COUPLERS							
4420000317	20,000	N/A	Wedge Latch	2-5/16"	N/A	Cast head, 4-1/2" mount pattern, grey primer coat	14.0
4425000317	25,000	N/A	Wedge Latch	2-5/16"	N/A	Cast head, 4-1/2" mount pattern, grey primer coat	15.0
ACCESSORY PART - WEDGE-LATCH® FLAT MOUNT CAST HEAD COUPLER							
PL4 0201		N/A	N/A	N/A	N/A	Pin/Lanyard 5/16" with 4 Link Chain & Tab	0.75
WEDGE-LATCH® ADJUSTABLE HEIGHT CAST HEAD COUPLERS							
A200C 0317	8,000	8-1/2"	Wedge Latch	2"	IV	Cast head includes mounting hardware, adjustable height	9.5
A2003C0317	8,000	9-1/4"	Wedge Latch	2"	IV	Cast head includes bolts and 3-position channel, adjustable height	13.7
A2005C0317	8,000	9-1/4"	Wedge Latch	2"	IV	Cast head includes bolts and 5-position channel, adjustable height	15.8
A256C 0317	14,000	9-1/4"	Wedge Latch	2-5/16"	IV	Cast head includes mounting hardware, adjustable height	10.1
A2563C0317	14,000	9-1/2"	Wedge Latch	2-5/16"	IV	Cast head includes bolts and 3-position channel, adjustable height	14.3
A2565C0317	14,000	9-1/2"	Wedge Latch	2-5/16"	IV	Cast head includes bolts and 5-position channel, adjustable height	16.4
ACCESSORY / REPLACEMENT PARTS - ADJUSTABLE HEIGHT CHANNEL BRACKET							
AC300 0300		8" Height	N/A	N/A	N/A	4-hole, 3-position bracket, with 4" of vertical adjustment, adjustable height	4.18
AC500 0300		11-3/4" Height	N/A	N/A	N/A	6-hole, 5-position bracket, with 8" of vertical adjustment, adjustable height	6.32
66 0801		N/A	N/A	2"	N/A	2" Ball size Wedge-Latch® repair kit. Includes latch lever, ball clamp, and replacement hardware	1.0
67 0801		N/A	N/A	2-5/16"	N/A	2-5/16" Ball size Wedge-Latch® repair kit. Includes latch lever, ball clamp, and replacement hardware	1.0

NOTE: Other custom-made designs are available upon request. ♦ DENOTES MOST POPULAR

HEAVY DUTY COUPLERS



A200S 0303



Actual product may vary slightly from image shown.

ADJUSTABLE HEIGHT COUPLERS

Part No.	Gross Trailer Weight	Overall Length	Ball	Description	Unit Wt. Lbs.
A200S 0303	8,000	9.00"	2"	Black Painted Finish, Mounting Hardware Included, Mounting Bracket Sold Separately	7.90
A256S 0303	14,000	9.50"	2-5/16"	Black Painted Finish, Mounting Hardware Included, Mounting Bracket Sold Separately	8.00

MOUNTING BRACKETS

Part No.	Overall Height	Description	Unit Wt. Lbs.
AC300 0300	8.00"	3 Position, Raw Finish, Mounting Hardware Sold Separately	4.20
AC500 0300	11.75"	5 Position, Raw Finish, Mounting Hardware Sold Separately	6.40
024202	n/a	Mounting Hardware, Individually Bagged	1.00



E338050303

YOKE COUPLER

Part No.	Gross Trailer Weight	Ball	Description	Unit Wt. Lbs.
E338050303	5,000	2"	Class III Coupler, Round Jack Mount 50° A-Frame, Black Painted Finish, Weld-on	7.80





ROUND GOOSENECK COUPLERS

BULLDOG gooseneck couplers are quick and easy to engage and strong and secure on the road. Our unique, patented, extruded locking plate design and high-strength steel components make BULLDOG gooseneck couplers 65% stronger than similar products.

- Easy-grip locking handle is accessible from any position, even with a glove on
- Self-centering locking plate lets you miss the ball by more than an inch
- Tight ball fit reduces jarring when changing speeds or on rough roads
- Heavy-duty construction provides unmatched strength
- User-friendly design is simple to use
- Quick to hook up and disconnect
- Easy vertical adjustment



0289500300



0287600300



GN24

0289500300
(shown with 63230 lock)

SQUARE GOOSENECK COUPLERS

You won't find a coupler that's faster or easier to use than the BULLDOG square gooseneck from Cequent Performance Products. Its user-friendly design makes hookup and release swift and secure.

- Easy-grip locking handle is accessible from any position
- Self-centering locking plate lets you miss the ball by more than an inch
- Tight ball fit reduces jarring when changing speeds or on rough roads
- Heavy-duty high-strength fabricated steel components are as strong as heavy cast iron but lighter and less brittle
- User-friendly design enables quick, easy hookup and release
- Locking handle cover protects working parts
- Cam locking pin affords easy vertical adjustment
- Pinch bolt design



028900



0289600300

KING PIN GOOSENECK COUPLERS

- Allows gooseneck trailer to be towed with vehicles equipped with a fifth wheel hitch
- Feature dual set bolts
- Round model features exclusive load bearing pin
- Square model features exclusive load bearing pinch bolt
- Available with or without outer tube



0289580300



0289590300

NOTE: All BULLDOG® Gooseneck Couplers are in compliance with the SAE standard J2638 .

WARNING

Failure to close coupler securely before towing or failure to use with specified ball size may result in serious injury or death.



ROUND GOOSENECK COUPLERS

Part No.	Capacity	Overall Height		Adjustment	Ball Size	Description	Unit Wt. Lbs.
		Retracted	Extended				
ROUND GOOSENECK FIXED COUPLER							
0287690300	20,000	33.00"	N/A		2-5/16"	Fixed base coupler.	38.0
ROUND GOOSENECK ADJUSTABLE COUPLER							
0287600300	20,000	29.20"	8.0"		2-5/16"	Adjustable gooseneck coupler.	46.0
0287610300	20,000	27.20"	8.0"		2-5/16"	Adjustable gooseneck coupler. No outer tube.	30.0
0289250300	25,000	29.30"	8.0"		2-5/16"	4.5" diameter outer tube, 4" diameter inner tube, with cast locking plates. 3/4" load bearing pin.	50.0
0289500300	30,000	29.30"	8.0"		2-5/16"	4.5" diameter outer tube, 4" diameter inner tube, with cast locking plates. 3/4" load bearing pin.	52.0
GOOSENECK COUPLER HEAD							
GN24 0200	24,000	N/A	N/A		2-5/16"	Cast steel gooseneck coupler designed for easy welding to 3" or 4" diameter tubing. Quick and easy latching action eliminates need to be in tow vehicle for hook-up.	5.5
GOOSENECK COUPLER OUTER TUBE							
0233010300						Outer tube only. 20" length, 4.5" round tube, with hole for 3/4" load bearing pin, (1) set bolt.	
0233050300						Outer tube only. 30" length, 4.5" round tube, with hole for 3/4" load bearing pin, (1) set bolt.	
0233100300						Outer tube only. 20" length, 4.5" round tube, with hole for 3/4" load bearing pin, (2) set bolts.	
REPLACEMENT PART - GOOSENECK COUPLER HEAD GN24 REPAIR KIT							
1542S01	N/A	N/A	N/A		N/A	Kit includes torsion spring, coupler locking shaft, curved handle assembly, 3/4" shaft retaining ring, centerlock nut 1/2-13	N/A
REPLACEMENT PART - GOOSENECK COUPLER KIT							
0287740300	N/A	N/A	N/A		2-5/16"	Kit includes coupler assembly, locking pin assembly, locking pin cover, bulldog label, and warning label.	10.0
0233060301	N/A	N/A	N/A		N/A	Replacement Pin Kit, includes cotter pin.	N/A

SQUARE GOOSENECK ADJUSTABLE COUPLERS

Part No.	Capacity	Overall Height		Adjustment	Ball Size	Description	Unit Wt. Lbs.
		Retracted	Extended				
0289600300	25,000	32"	40"	8"	2-5/16"	4.5" square outer tube, 4.0" square inner tube. (1) 3/4" diameter set screw.	57.0
028900	30,000	32"	39"	7"	2-5/16"	4.5" square outer tube with .25" wall, 4.0" square inner tube with .313" wall. Includes topwind crank.	76.0
0289800300	30,000	32"	40"	8"	2-5/16"	4.5" square outer tube with, 4.0" square inner tube. (2) 3/4"diameter set bolts.	68.0

KING PIN GOOSENECK COUPLERS

Part No.	Capacity	Overall Height		Adjustment	Ball Size	Description	Unit Wt. Lbs.
		Retracted	Extended				
0289580300	25,000	23.3"	31.3"	8"	N/A	Round tube , raw finish, labels shipped loose.	56.0
0289640300	25,000	23.3"	31.3"	8"	N/A	Round tube , raw finish, labels shipped loose. Inner tube only.	56.0
0289590300	30,000	23.3"	31.3"	8"	N/A	Square tube , raw finish, labels shipped loose.	66.0
0289650300	30,000	23.3"	31.3"	8"	N/A	Square tube , raw finish, labels shipped loose. Inner tube only.	51.0

SERVICE KIT FOR SQUARE / SQUARE KING PIN GOOSENECK ADJUSTABLE COUPLERS

Part No.	Description
0289SB0140	Adjustable gooseneck pinch bolt kit



BX1 GOOSENECK COUPLERS

The BULLDOG BX1 coupler is the result of generations of design expertise and field experience. It incorporates innovative features that revolutionize the benefits available from a gooseneck coupler.

- Offers flexible mounting options with Next Generation locking plate coupler locking mechanism
- Makes hooking up, adjusting vertical height, and disconnecting quick and easy
- Maintains smooth operation over time with grease fittings for every important operating part
- Operates easily with one hand thanks to new locking handle design
- Provides continuous tight ball fit with ever-increasing cam tightening locking mechanism
- Protects against wear with enclosed locking pin mechanism
- Resists theft with integrated feature to allow pad-locking the coupler to the ball (lock not included)
- Guides ball into socket more easily—letting you miss by more than an inch—with bottom locking plate 50% larger than competitors
- Lengthens life of locking mechanism with oil-impregnated bushings
- Allows shorter retracted length and less wasted length for trucks with high bed height via low-profile locking mechanism
- Fits ball better and reduces jarring through contour-formed edge on bottom locking plate
- Delivers unmatched strength through heavy-duty construction
- Includes many modern innovations that improve security, service life, and functionality
- New ball pocket design provides contact on both sides of the ball for substantially improved pull out strength - the only sliding-plate design that transfers part of the load to the top locking plate rather than only the bottom locking plate

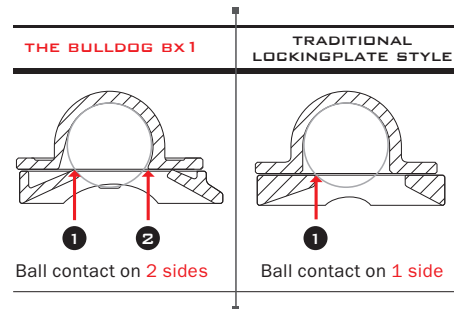

BX1 GOOSENECK COUPLERS

Part No.	Capacity	Overall Height		Adjustment	Ball Size	Description	Unit Wt. Lbs.
		Retracted	Extended				
1289000300	25,000	27.5"	35.5"	8"	2-5/16"	BX1 Coupler with outer tube	48.0
1289020300	25,000	N/A	N/A	8"	2-5/16"	BX1 Coupler less outer tube	31.0
SERVICE KIT							
500289	-	-	-	-	-	Service kit for BX1 Gooseneck Coupler handle mechanism	-

Patents Pending.

ROUND GOOSENECK COUPLERS



- 8" of Adjustment
- Handle hold-open feature
- Raw Finish
- 2 5/16" Ball Size
- P/N 0287820300 includes loading bearing pin

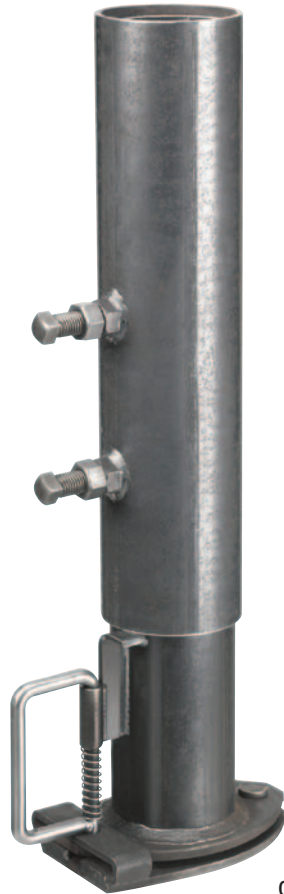

0287800300



Handle Hold-Open



0287820300



Load Bearing Pin

ROUND GOOSENECK COUPLERS

Part No.	Capacity	Overall Height Retracted	Adjustment	Ball Size	Description	Unit Wt. Lbs.
0287790300	20,000	26.70"	8.0"	2-5/16"	Raw Finish, 2 Set Screws	43.00
0287800300	25,000	26.70"	8.0"	2-5/16"	Raw Finish, 2 Set Screws	47.00
0287820300	25,000	26.70"	8.0"	2-5/16"	Raw Finish, 1 Set Screw, Load Bearing Pin	47.00

THE SAE INTERNATIONAL J2638 STANDARD FOR GOOSENECK AND 5TH WHEEL TRAILERS UNDER 30,000 LBS.



The Society of Automotive Engineers (SAE) is a non-profit educational and scientific organization dedicated to advancing mobility technology to better serve humanity. SAE has developed many standards, testing methods and procedures to measure the performance of vehicles and vehicle related products, including trailers. SAE J2638 addresses both gooseneck and 5th wheel trailers under 30,000 lbs. The testing methods for gooseneck are as follows:

TESTING METHODS

STATIC TESTING is a one time maximum load requirement for the three test conditions.

The test is to be maintained for 5 Seconds.

- **Vertical** - tests the goosenecks ability with upward and downward pressure
 - 85% of GVW Pull Out (25K lb Gooseneck = 21,250 lbs)
 - 50% of GVW Down (25K lb Gooseneck = 12,500 lbs)
- **Longitudinal** - tests the goosenecks ability with front and back pressure
 - 75% of GVW Front and Back (25K lb Gooseneck = 18,750 lbs)
- **Transverse** - tests the goosenecks ability with side to side pressure
 - 30% of GVW Each Side (25K lb Gooseneck = 7,500 lbs)

DYNAMIC TESTING defines requirements for repetitive testing in the three test conditions.

- 300,000 Cycles in each test condition. (Vertical, Longitudinal and Transverse)
- The same unit is used for all three tests. (900,000 Cycles all together)
- The range of load requirements are based on GVW and Rated Coupler Load.

In order to assure safety and accountability for the products produced, SAE J2638 also requires:

- Product Identification
 - Manufacturer's Name
 - Maximum Trailer GVW
 - Rated Vertical Coupler Load
 - Ball Size
- Testing
 - Products are to be fixtured at the maximum stress conditions
 - There should be no loss of attachment during testing
 - When testing is completed, the coupler will be capable of being uncoupled and coupled

CEQUENT COMMITMENT

As the leading manufacturer of gooseneck couplers, Cequent understands the importance of the new SAE standard for Goosenecks and 5th Wheels. We are committed to providing products that meet or exceed these recommendations and our commitment is evident by our investment in people and facilities dedicated to testing our products.

In addition to being one of the only manufacturers with dedicated testing facilities, Cequent also has over 90 years of manufacturing experience to insure our products are of the highest quality and reliability.

Because of the size of our organization we can provide the added benefits of high quality, unmatched reliability and proven strength, at a competitive price.

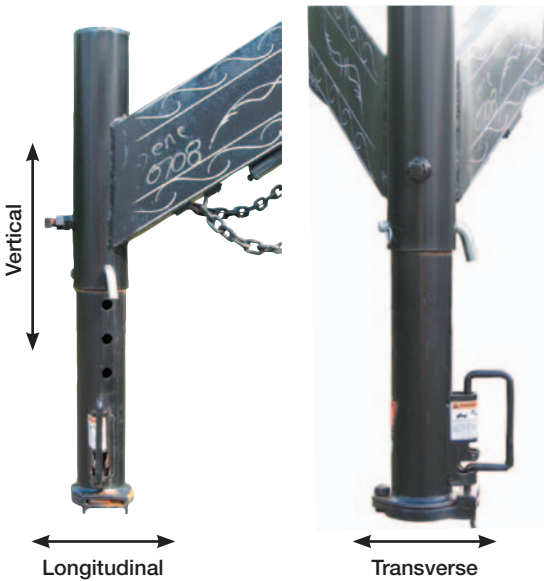

Competitor's 25K gooseneck fails longitudinal test at 11,500 lbs.



22300

FULTON

STAMPED COUPLERS

The most popular coupler mechanism ever developed, the Fas-Lok® originated as a Fulton brand and is offered in a full line of SAE Class I through IV rated straight tongue stamped couplers. The Fas-Lok® latching mechanism allows quick and easy trailer hook-up, and is factory adjusted for convenience.



34300

STAMPED COUPLERS



Straight Tongue Fas-Lok®
Quick and easy trailer hook-up.



A-Frame
High-strength stamped couplers
for 50-degree frames.



44314R
US Patent
6,505,849

HANDI-GRIP COUPLER HANDLE



STAMPED COUPLERS WITH Z-MAX 600 SUPERIOR PLATING



Fulton coupler after
336 hours salt spray testing.



Competitor's coupler
after 336 hours salt spray testing.



STAMPED COUPLERS - STRAIGHT TONGUE STAMPED FAS-LOK® COUPLERS

Part No.	Gross Trailer Weight	Ball Size	SAE Class	Description	Finish	Packaging
E112000340	2,000	1-7/8"	I	2" Wide Channel, Clear Zinc Finish, No Product Label	100 Hr.	Bulk
11200 0317	2,000	1 7/8"	I	2" Wide Channel, Primed Finish, No Product Label	Primed	Bulk
11200 0101	2,000	1-7/8"	I	2" Wide Channel, Clear Zinc Finish, Labeled	100 Hr.	Ind. Labeled
E112500340	2,000	1-7/8"	I	2-1/2" Wide Channel, Clear Zinc Finish, No Product Label	100 Hr.	Bulk
11250 0317	2,000	1 7/8"	I	2 -1/2" Wide Channel, Primed Finish, No Product Label	Primed	Bulk
E113000340	2,000	1-7/8"	I	3" Wide Channel, Clear Zinc Finish, No Product Label	100 Hr.	Bulk
11300 0317	2,000	1 7/8"	I	3" Wide Channel, Primed Finish, No Product Label	Primed	Bulk
11300 0101	2,000	1-7/8"	I	3" Wide Channel, Clear Zinc Finish, Labeled	100 Hr.	Ind. Labeled
22200 0101	3,500	2"	II	2" Wide Channel, Labeled	Z-Max 600	Ind. Labeled
22200 0301	3,500	2"	II	2" Wide Channel, No Product Label	Z-Max 600	Bulk
22200 0317	3,500	2"	II	2" Wide Channel, Primed Finish, No Product Label	Primed	Bulk
22250 0101	3,500	2"	II	2-1/2" Wide Channel, Labeled	Z-Max 600	Ind. Labeled
22250 0301	3,500	2"	II	2-1/2" Wide Channel, No Product Label	Z-Max 600	Bulk
22250 0317	3,500	2"	II	2 -1/2" Wide Channel, Primed Finish, No Product Label	Primed	Bulk
22300 0101	3,500	2"	II	3" Wide Channel, Labeled	Z-Max 600	Ind. Labeled
22300 0301	3,500	2"	II	3" Wide Channel, No Product Label	Z-Max 600	Bulk
22300 0317	3,500	2"	II	3" Wide Channel, Primed Finish, No Product Label	Primed	Bulk
34300 0301	5,000	2"	III	3" Wide Channel, No Product Label	Z-Max 600	Bulk
34300 0317	5,000	2"	III	3" Wide Channel, Primed Finish, No Product Label	Primed	Bulk
34600 0301	6,000	2"	IV	3" Wide Channel, Cast Ball Clamp, No Product Label	Z-Max 600	Bulk

STAMPED COUPLERS - A-FRAME STAMPED COUPLERS

Part No.	Gross Trailer Weight	Ball Size	SAE Class	Description	Finish	Packaging
E333050303	5,000	2"	III	50 Degree A-Frame (Weld-On)	Black Primed	Bulk
E443050303	10,000	2-5/16"	IV	50 Degree A-Frame (Weld-On), Low Profile Latch	Black Primed	Bulk
44305R0317	10,000	2-5/16"	IV	50 Degree A-Frame (Weld On), Wedge-Latch®	Primed	Bulk
44305R0500	10,000	2-5/16"	IV	50 Degree A-Frame (Weld On), Wedge-Latch®	Oily	Bulk
44314R0303	14,000	2-5/16"	IV	50 Degree A-Frame (Weld On), Wedge-Latch®	Black Paint	Bulk

STAMPED COUPLERS - HANDWHEEL COUPLERS

Part No.	Gross Trailer Weight	Ball Size	SAE Class	Description	Finish	Packaging
308 0217	5,000	2" - 2-1/8"	III	2-7/8" Channel, Handwheel Latch	Primed	Ind. Labeled
308 0317	5,000	2" - 2-1/8"	III	2-7/8" Channel, Handwheel Latch	Primed	Bulk

STAMPED COUPLERS - COUPLER ACCESSORIES / REPLACEMENT PARTS

Part No.	Description	Packaging
CH 0701	Handi-Grip Coupler Handle	Carded
52 0801	Kit, 308 repair, handwheel couplers	Poly Bag
64 0801	Kit, 44305R, coupler replacement	Poly Bag

*Couplers do not include hitch balls. Class III hardware couplers can be used on Class II trailers.
NOTE: Review price list or contact customer service for package quantities and full part number.*

⚠ WARNING

Failure to close coupler securely before towing or failure to use with specified ball size may result in serious injury or death.



FOLD-AWAY™ COUPLERS / HINGE KITS

Fulton High Performance Series Fold-Away™ coupler and hinge kits are ideal for boat trailers that can be just a little too long to fit inside smaller garages. These high quality, precision engineered products provide three options for solving this common problem. Choose the Fold-Away™ product that fits your needs from among several varieties made to fit standard trailer tongue dimensions.

Models with Z-Max 600-hour zinc plating provide protection 6 times longer than typical zinc finishes. By far the best finish in the industry, Z-Max 600 is tested per ASTM B117. Bolt-on and weld-on kits with raw finish are ideal for painting or galvanizing.



Limited 5-year warranty.

FOLD-AWAY™ COUPLERS

- Replace existing couplers on trailers with 3500 lb. & 5000 lb. weight capacities
- Shortens trailer tongue by 34"
- Unique patented offset design
- Meets SAE J684 requirements
- Easy to install bolt-on application with complete instruction manual
- Includes all mounting hardware

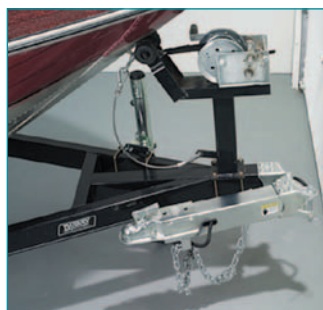
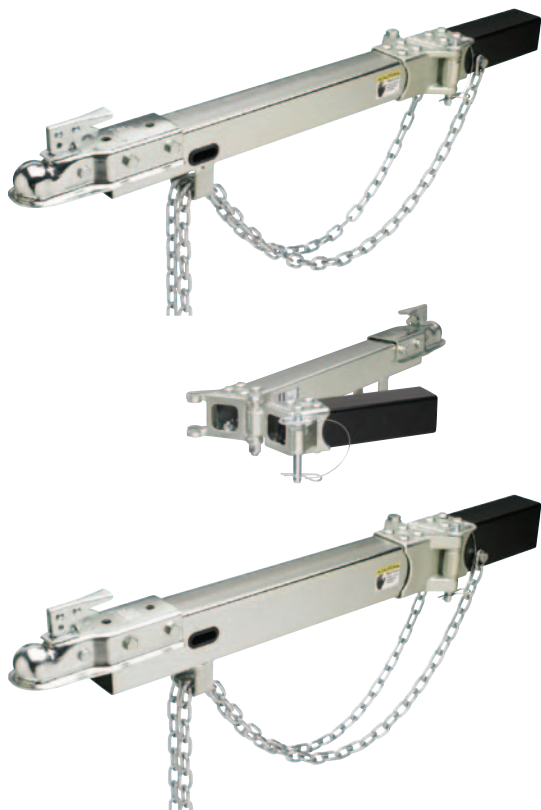

Fold-Away™ coupler now available in aftermarket box and bulk.

Space Saving!



BOLT-ON
Easy-to-install

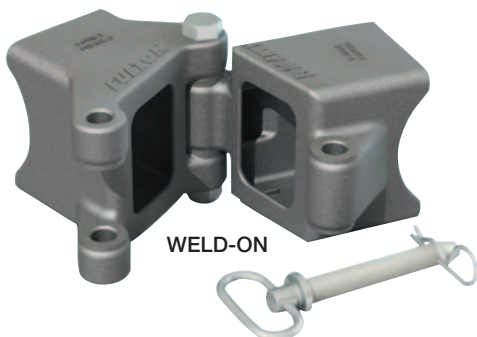

WELD-ON

FOLD-AWAY™ BOLT-ON HINGE KITS

- Converts standard trailer tongues into fold-away configurations while preserving the existing coupler
- Delivers strength at the pivot point with precisely machined heavy duty hinges made from die cast steel
- Easy to install bolt-on application with complete instruction manual
- Includes all mounting hardware

FOLD-AWAY™ WELD-ON HINGE KITS

- Ideal for OEMs, a convenient option for custom trailers to utilize a pivot system
- Delivers strength at the pivot point with precisely machined heavy-duty hinges made from die cast steel
- Provides superior performance with unique patent pending offset design
- Works with actuators and standard coupler applications, note gross trailer weight



FOLD-AWAY™ COUPLERS

(Consult pivot rating charts on following page for allowed capacity.)

Part No.	Gross Trailer Weight	Ball Size	SAE Class	Pivot Length	Description	Finish	Packaging
HPB3530101	3,500	2"	II	34"	34" Coupler Kit, 3" x 3" Trailer Tongues, Bolt On	Z-Max 600	Display Box
HPB3530301	3,500	2"	II	34"	34" Coupler Kit, 3" x 3" Trailer Tongues, Bolt On	Z-Max 600	Bulk
HPB3540101	3,500	2"	II	34"	34" Coupler Kit, 3" x 4" Trailer Tongues, Bolt On	Z-Max 600	Display Box
HPB3540301	3,500	2"	II	34"	34" Coupler Kit, 3" x 4" Trailer Tongues, Bolt On	Z-Max 600	Bulk
HPB5040101	5,000	2"	III	34"	34" Coupler Kit, 3" x 4" Trailer Tongues, Bolt On	Z-Max 600	Display Box
HPB5040301	5,000	2"	III	34"	34" Coupler Kit, 3" x 4" Trailer Tongues, Bolt On	Z-Max 600	Bulk

Includes Fold-Away hinges, mounting hardware, pivot bolt, pivot pin/clip, extension tube and coupler.
Chains and torques bit included with retail display box packaged items.

FOLD-AWAY™ BOLT-ON HINGE KITS

(Consult pivot rating charts on following page for allowed capacity.)

Part No.	Gross Trailer Weight	Ball Size	SAE Class	Pivot Length	Description	Finish	Packaging
HDPB230101	Up To 5,000	N/A	N/A	Up to 48"	Bolt-On Hinge Kit, 2" x 3" Trailer Tongues	Z-Max 600	Display Box
HDPB230301	Up To 5,000	N/A	N/A	Up to 48"	Bolt-On Hinge Kit, 2" x 3" Trailer Tongues	Z-Max 600	Bulk
HDPB330101	Up To 5,000	N/A	N/A	Up to 48"	Bolt-On Hinge Kit, 3" x 3" Trailer Tongues	Z-Max 600	Display Box
HDPB330301	Up To 5,000	N/A	N/A	Up to 48"	Bolt-On Hinge Kit, 3" x 3" Trailer Tongues	Z-Max 600	Bulk
HDPB340101	Up To 7,500	N/A	N/A	Up to 48"	Bolt-On Hinge Kit, 3" x 4" Trailer Tongues	Z-Max 600	Display Box
HDPB340301	Up To 7,500	N/A	N/A	Up to 48"	Bolt-On Hinge Kit, 3" x 4" Trailer Tongues	Z-Max 600	Bulk
HDPB350101	Up To 9,000	N/A	N/A	Up to 48"	Bolt-On Hinge Kit, 3" x 5" Trailer Tongues	Z-Max 600	Display Box
HDPB350301	Up To 9,000	N/A	N/A	Up to 48"	Bolt-On Hinge Kit, 3" x 5" Trailer Tongues	Z-Max 600	Bulk

Includes Fold-Away hinges, mounting hardware, pivot bolt, pivot pin/clip.
Torques bit included with retail display box packaged items.

FOLD-AWAY™ WELD-ON HINGE KITS

(Consult pivot rating charts on following page for allowed capacity.)

Part No.	Gross Trailer Weight	Ball Size	SAE Class	Pivot Length	Description	Finish	Packaging
HDPW230300	Up To 5,000	N/A	N/A	Up to 48"	Weld-On Hinge Kit, 2" x 3" Trailer Tongues	Raw Casting	Bulk
HDPW330300	Up To 5,000	N/A	N/A	Up to 48"	Weld-On Hinge Kit, 3" x 3" Trailer Tongues	Raw Casting	Bulk
HDPW340300	Up To 7,500	N/A	N/A	Up to 48"	Weld-On Hinge Kit, 3" x 4" Trailer Tongues	Raw Casting	Bulk
HDPW350300	Up To 9,000	N/A	N/A	Up to 48"	Weld-On Hinge Kit, 3" x 5" Trailer Tongues	Raw Casting	Bulk

Includes Fold-Away hinges (raw finish castings ideal for painting or galvanizing), zinc plated pivot bolt and nut, 5/8" diameter hitch pin and clip.

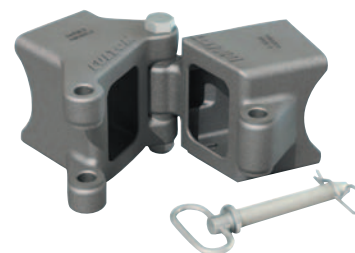
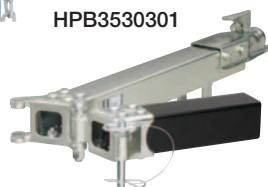

PIVOT RATING CHARTS

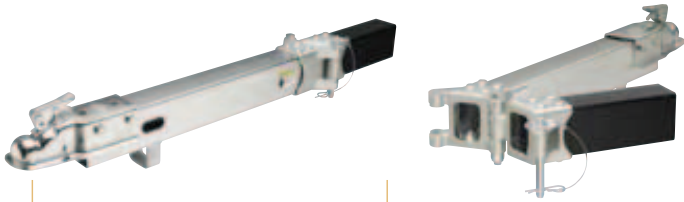

Fold-Away Couplers

Fulton High Performance Series Fold-Away Couplers replace existing couplers on trailers with 3500 lb. & 5000 lb. weight capacities.

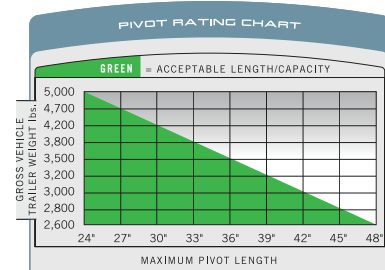

2" x 3" TRAILER TONGUES

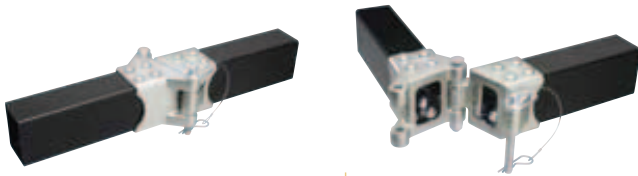

Fold-Away Bolt-On Hinge Kits

Fulton Fold-Away Bolt-on Hinge Kits convert standard trailer tongues into fold-away configurations while preserving the existing coupler.

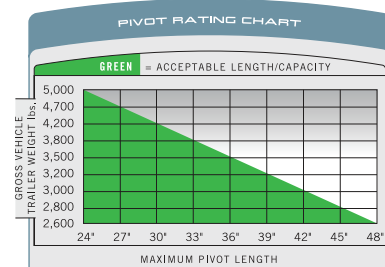

3" x 3" TRAILER TONGUES

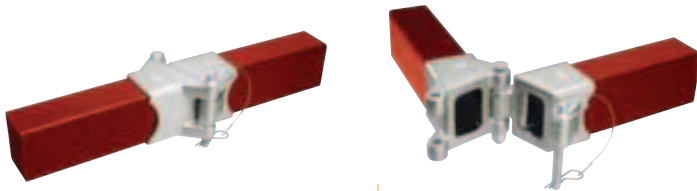

Fold-Away Weld-On Hinge Kits

Ideal for OEMs, Fulton Fold-Away Weld-on Hinge Kits are a convenient option for custom trailers to utilize a pivot system.

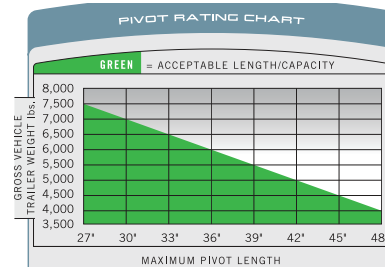

3" x 4" TRAILER TONGUES

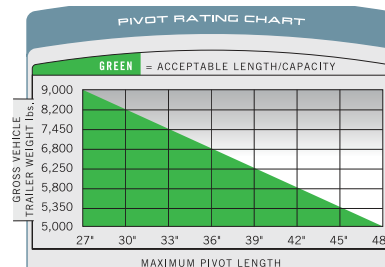
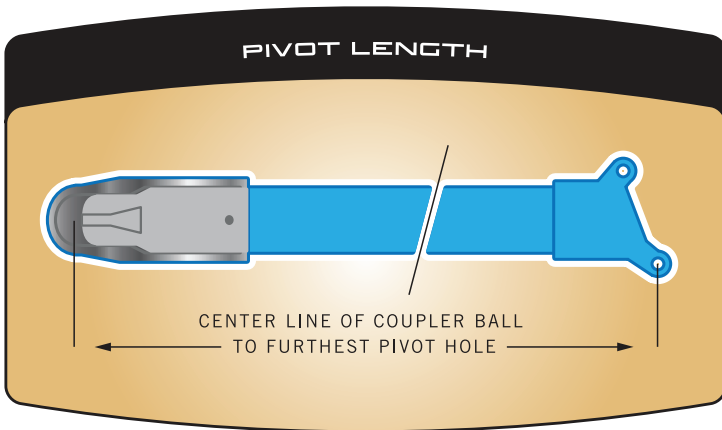

3" x 5" TRAILER TONGUES

Need a Winch? Does the application require Pulling or Lifting?

STAMPED COUPLERS - SELECT A FULTON "T" SERIES TRAILER WINCH

To Select T Winch Capacity:

Minimum Winch Capacity = Maximum Weight of Boat, Including Motor, Fuel, Gear ÷ 2

Example:

Boat, Motor, Fuel, Gear Weight = 2,800 lbs.
 $2,800 \div 2 = 1,400$ lbs.

Select T1500 Winch, rated at 1,500 lbs.



XLT18



T3700

If shallow water or steep inclined launches are expected to be used ÷ Maximum Weight by 1.5

Example:

Boat, Motor, Fuel, Gear Weight = 3,100 lbs.
 $3,100 \div 1.5 = 2,067$ lbs.

Select T2100 Winch, rated at 2,100 lbs.



COMMON PULLING APPLICATION



LIFTING - SELECT A FULTON "K" SERIES BRAKE WINCH

To Select T Winch Capacity:

Minimum Winch Capacity = Maximum Weight of Boat, Including Motor, Fuel, Gear ÷ 2

Example:

Boat, Motor, Fuel, Gear Weight = 2,800 lbs.
 $2,800 \div 2 = 1,400$ lbs.

Select T1500 Winch, rated at 1,500 lbs.



K2550



KW3000

COMMON LIFTING APPLICATIONS



NOTES

1. Fulton Winches are not designed to be human hoists and should never be operated when there are persons on or under the load being moved.
2. Fulton Winches are rated on the first layer of recommended line on the drum. For maximum efficiency use only the amount of line required. Derate the capacity 10% per additional layer of rope, strap, or cable.



F2® SINGLE SPEED TRAILER WINCH

Fulton continues to expand the F2 series of products with the introduction of the 1600 lb. F2 Single Speed Trailer Winch. Enclosed frame for performance and style, this 1600 lb. winch is user-friendly, sleek and reliable. Attractive design is styled to compliment the F2 jack series for a custom look.

- Compact design
- Enclosed frame design for a sleek, strong stylish look
- Two piece corrosion resistant aluminum frame
- One piece corrosion resistant aluminum handle
- Dual gear drum operates smoothly
- Handle switches from left to right hand drive
- Handle is easily adjustable - 6" to 7"
- Soft ergonomic grip
- Features E.I.S. - "Easy Install System"
- Strap and mounting hardware included in Display Box packaged product
- CE Compliant
- Limited Lifetime Warranty



E.I.S. - Easy Install System



Adjustable Handle

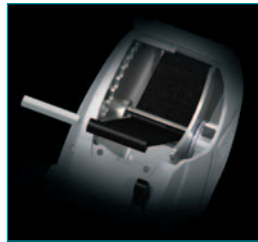

Hub Mounted Strap



PREMIUM FINISH

- Environmentally friendly
- Self-healing
- Maximum corrosion resistance
- Used in salt water environments and other demanding climate applications
- 1200 hour salt spray rating per ASTM B117

F2® TRAILER WINCHES

Part No.	Capacity	Gear Ratio	Handle Length	Strap	Strap Included	Finish	Packaging	Unit Wt. Lbs.
FW16000101	1,600	4.1:1	2 Position 6", 7"	20'	YES	Sharkskin	Display Box	9.25
FW16000301	1,600	4.1:1	2 Position 6", 7"	N/A	NO	Sharkskin	Bulk	7.85

Patent Pending.

F2® SINGLE SPEED TRAILER WINCH

The F2® Winch addresses the need for attractive design in every element of a marine trailer. This 2000 lb. capacity winch will complement the look of even high end boat and trailer combinations and continues the industry-changing improvements in both performance and style of the Fulton F2® series of products. Its clean, high-tech look is sleek and powerful.

- Completely enclosed stylish design – compliment your boat and customize your trailer’s styling
- 2000 lb. capacity
- E.I.S. - Easy Install System
- Precision fit components eliminate tightening or replacement
- Maintenance free – designed to eliminate the need for lubrication or maintenance
- Corrosion-resistant coating resists damage from moisture and salt
- Corrosion-resistant one-piece aluminum frame and one-piece aluminum handle
- Smooth reliable solid drive gear and powerful dual gear drum
- Center drive enclosed ratchet system
- User-friendly pull-turn knob to engage ratchet plunger pin
- Adjustable-length soft grip handle, switches from left- to right-hand drive configuration
- Includes 20’ strap with hook
- Standard mounting bolt pattern, mounting hardware included, (footprint 8”H x 6.5”W x 9.5”D)
- **CE** Compliant
- Limited Lifetime Warranty



FW20000101



E.I.S. - Easy Install System



Adjustable Handle



Easy Ratchet System

F2® TWO SPEED TRAILER WINCH

With its completely enclosed design, Fulton® expands the F2 Series of products with the introduction of the F2 Two Speed Trailer Winch. This 3200 lb. capacity winch is user-friendly, sleek, and reliable. The self-engaging one-handed system shifts from high to low speed.

- Completely enclosed design
- 3,200 lb. capacity
- Includes all mounting hardware, E.I.S. – Easy Install System
- Ergonomic 4-position adjustable handle adjusts from 6”–9”
- Center drive enclosed ratchet
- User-friendly pull-turn knob to engage ratchet plunger pin
- Includes strap guide and 20’ heavy duty strap with hook
- Patents pending
- **CE** Compliant
- Limited Lifetime Warranty



PREMIUM FINISH

- Environmentally friendly
- Self-healing
- Maximum corrosion resistance
- Used in salt water environments and other demanding climate applications
- 1200 hour salt spray rating per ASTM B117

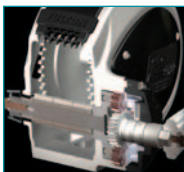

2 Speed Gear System



Neutral



Low Speed



High Speed



FW32000101

F2® TRAILER WINCHES

Part No.	Capacity	Gear Ratio	Handle Length	Strap	Strap Included	Finish	Packaging	Unit Wt. Lbs.
F2® SINGLE SPEED TRAILER WINCH								
FW20000101	2,000	5.1:1	4 Position 6", 7", 8", 9"	20' x 2" w/Hook	YES	Sharkskin™	Display Box	6.7
FW20000301	2,000	5.1:1	4 Position 6", 7", 8", 9"	20' x 2" w/Hook	YES	Sharkskin™	Bulk	6.7
F2® TWO SPEED TRAILER WINCH								
FW32000101	3,200	5.1:1, 3.17:1	4 Position 6", 7", 8", 9"	20' x 2" Heavy Duty w/Hook	YES	Sharkskin™	Display Box	15.7
FW32000301	3,200	5.1:1, 3.17:1	4 Position 6", 7", 8", 9"	20' x 2" Heavy Duty w/Hook	YES	Sharkskin™	Bulk	15.7

FULTON

SINGLE SPEED TRAILER WINCHES



We manufacture a full line of Fulton brand single speed winches designed to meet your toughest pulling demands. Our winches feature efficient gear ratios, full-length drum bearings, oil-impregnated shaft bushings, and our "Comfort Grip" handle for ease of cranking. All gears are high-carbon steel for superb strength and long-term durability. Stamped carbon steel frames provide rigidity for gear alignment and longer cycle life. Zinc finishes provide excellent corrosion resistance in all environments. All models are designed for use with rope or strap. For end user convenience, most models are available with factory installed straps and hooks. Our XLT® Series includes stylized polypropylene shell with strap and hook as standard features. The T1300 and T1500 models offer optional gear covers, gear train protection, and added styling like T1500ZC.

CE Compliant



XLT14
Winch Housing US Patent
D407,883
Cover Plate US Patent
D395,116



T1500ZC
*(ZC-models include
strap, hook, and cover)*
US Patent D434,892

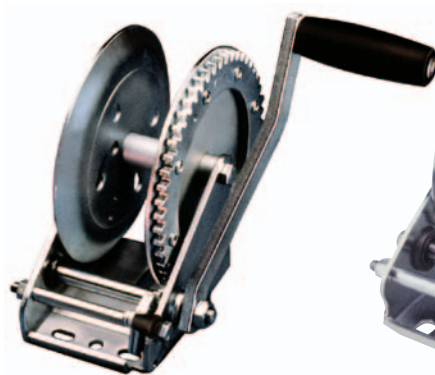

T1602



T1100



SINGLE SPEED TRAILER WINCHES

Part No.	Capacity	Gear Ratio	Handle Length	Max. Merch. Adv.**	Ratchet Type	Drum Storage			Strap Mfg. Bolt Sizes (Not Included)	Replace Handle	Strap Included	Packaging
						Rope	Cable	Strap				
T600 0101	600	3.1:1	6"	34:1	Two-way	36' x 1/4"	N/A	15' x 2"	1/4" x 2-1/2" Grade 5	5868	NO	Litho Box
T600 0301	600	3.1:1	6"	34:1	Two-way	36' x 1/4"	N/A	15' x 2"	1/4" x 2-1/2" Grade 5	5868	NO	Bulk
T600Z0301	600	3.1:1	6"	34:1	Two-way	36' x 1/4"	N/A	15' x 2"	1/4" x 2-1/2" Grade 5	5868	YES	Bulk
T900 0101	900	3.1:1	7"	39:1	Two-way	36' x 1/4"	N/A	15' x 2"	1/4" x 2-1/2" Grade 5	6312	NO	Litho Box
T900 0301	900	3.1:1	7"	39:1	Two-way	36' x 1/4"	N/A	15' x 2"	1/4" x 2-1/2" Grade 5	6312	NO	Bulk
T900Z0101	900	3.1:1	7"	39:1	Two-way	36' x 1/4"	N/A	15' x 2"	1/4" x 2-1/2" Grade 5	6312	YES	Litho Box
T900Z0301	900	3.1:1	7"	39:1	Two-way	36' x 1/4"	N/A	15' x 2"	1/4" x 2-1/2" Grade 5	6312	YES	Bulk
T903Z 0101	900	3.1:1	6"	39:1	Two-way	36' x 1/4"	N/A	12' x 2"	1/4" x 2-1/2" Grade 5	6312	YES	Litho Box
T903Z 0301	900	3.1:1	6"	39:1	Two-way	36' x 1/4"	N/A	12' x 2"	1/4" x 2-1/2" Grade 5	6312	YES	Bulk
T1100 0101	1,100	4.1:1	7"	43:1	Two-way	30' x 5/16"	N/A	20' x 2"	1/4" x 2-1/2" Grade 5	6312	NO	Litho Box
T1100 0301	1,100	4.1:1	7"	43:1	Two-way	30' x 5/16"	N/A	20' x 2"	1/4" x 2-1/2" Grade 5	6312	NO	Bulk
T1100Z0101	1,100	4.1:1	7"	43:1	Two-way	30' x 5/16"	N/A	20' x 2"	1/4" x 2-1/2" Grade 5	6312	YES	Litho Box
T1300 0101	1,300	4.1:1	8"	49:1	Two-way	30' x 5/16"	N/A	20' x 2"	1/4" x 2-1/2" Grade 5	6302	NO	Litho Box
T1300 0301	1,300	4.1:1	8"	49:1	Two-way	30' x 5/16"	N/A	20' x 2"	1/4" x 2-1/2" Grade 5	6302	NO	Bulk
T1300Z0101	1,300	4.1:1	8"	49:1	Two-way	30' x 5/16"	N/A	20' x 2"	1/4" x 2-1/2" Grade 5	6302	YES	Litho Box
XLT14ZB101	1,400	4.1:1	8"	43:1	Two-way	N/A	N/A	20' x 2"	5/16" x 2-1/2" Grade 5	6302	YES	Litho Box
XLT14ZB301	1,400	4.1:1	8"	43:1	Two-way	N/A	N/A	20' x 2"	5/16" x 2-1/2" Grade 5	6302	YES	Bulk
T1500 0101	1,500	4.1:1	8"	49:1	Two-way	20' x 5/16"	N/A	20' x 2"	1/4" x 2-1/2" Grade 5	6302	NO	Litho Box
T1500 0301	1,500	4.1:1	8"	49:1	Two-way	20' x 5/16"	N/A	20' x 2"	1/4" x 2-1/2" Grade 5	6302	NO	Bulk
T1500Z0101	1,500	4.1:1	8"	49:1	Two-way	20' x 5/16"	N/A	20' x 2"	1/4" x 2-1/2" Grade 5	6302	YES	Litho Box
T1500Z0301	1,500	4.1:1	8"	49:1	Two-way	20' x 5/16"	N/A	20' x 2"	1/4" x 2-1/2" Grade 5	6302	YES	Bulk
T1602 0101	1,600	5.1:1	9"	56:1	Two-way	20' x 7/16"	N/A	20' x 2"	3/8" x 2-3/4" Grade 5	6822	NO	Litho Box
T1602 0301	1,600	5.1:1	9"	56:1	Two-way	20' x 7/16"	N/A	20' x 2"	3/8" x 2-3/4" Grade 5	6822	NO	Bulk
T1801 0101	1,800	5.1:1	10"	62:1	Two-way	20' x 7/16"	N/A	20' x 2"	3/8" x 2-3/4" Grade 5	6817	NO	Litho Box
T1801 0301	1,800	5.1:1	10"	62:1	Two-way	20' x 7/16"	N/A	20' x 2"	3/8" x 2-3/4" Grade 5	6817	NO	Bulk
T1801Z0101	1,800	5.1:1	10"	62:1	Two-way	20' x 7/16"	N/A	20' x 2"	3/8" x 2-3/4" Grade 5	6817	YES	Litho Box
T1801Z0301	1,800	5.1:1	10"	62:1	Two-way	20' x 7/16"	N/A	20' x 2"	3/8" x 2-3/4" Grade 5	6817	YES	Bulk
XLT18ZB101	1,800	5.1:1	10"	62:1	Two-way	N/A	N/A	20' x 2"	3/8" x 2-3/4" Grade 5	6817	YES	Litho Box
XLT18ZB301	1,800	5.1:1	10"	62:1	Two-way	N/A	N/A	20' x 2"	3/8" x 2-3/4" Grade 5	6817	YES	Bulk
T2100 0301	2,100	5.1:1	10"	62:1	Two-way	20' x 7/16"	N/A	20' x 2"	3/8" x 2-3/4" Grade 5	6817	NO	Bulk

CE All Cequent Performance Products single speed trailer winches are **CE** compliant.

**Maximum Mechanical Advance - Based on first layer of recommended line on the drum.
For maximum efficiency, use only the amount of line required.



XLT20ZB

FULTON

TWO SPEED TRAILER WINCHES

Make light work of heavy loads with Fulton brand two-speed winches. One fast speed for quick pull-in, a second low speed for increased mechanical advantage. Our shift lock design allows changing gears without moving the crank handle from shaft to shaft. Just lift the shift lock and slide the shaft into the desired gear position. Shift lock holds the shaft in gear. Neutral, free-wheel position allows quick line pay out without spinning the handle. Our ratchet pawl also has a convenient neutral position. Optional handbrake kit no. 1619-01 purchased separately and available for all two-speed winches and can be installed after the winch is mounted.

Our XLT® series includes stylized polypropylene shell with strap and hook as standard features.

CE Compliant



T2005



T2605



T2605Z



TWO SPEED TRAILER WINCHES

Part No.	Cap.	Gear Ratio	Handle Length	Max. Merch. Adv**	Ratchet Type	Drum Storage			Strap Mfg. Bolt Sizes (Not Included)	Hub Size	Hand Brake	Replace Handle	Strap Includ.	Cable Includ.	Pkg.
						Rope	Cable	Strap							
T2005 0101	2,000	4.1:1 & 9.8:1	10"	87:1	Two-way w/neutral	20' x 7/16"	N/A	N/A	N/A	1"	1619-01***	6817	N/A	N/A	Litho Box
T2005 0301	2,000	4.1:1 & 9.8:1	10"	87:1	Two-way w/neutral	20' x 7/16"	N/A	N/A	N/A	1"	1619-01***	6817	N/A	N/A	Bulk
T2005Z0101	2,000	4.1:1 & 9.8:1	10"	87:1	Two-way w/neutral	N/A	N/A	20' x 2"	3/8" x 2-3/4" grade 5	1"	1619-01***	6817	YES	N/A	Litho Box
T2005Z0301	2,000	4.1:1 & 9.8:1	10"	87:1	Two-way w/neutral	N/A	N/A	20' x 2"	3/8" x 2-3/4" grade 5	1"	1619-01***	6817	YES	N/A	Bulk
XL20ZB301	2,000	4.1:1 & 9.8:1	10"	87:1	Two-way w/neutral	N/A	N/A	20' x 2"	3/8" x 2-3/4" grade 5	1"	1619-01***	6817	YES	N/A	Bulk
T2005S0301	2,000	4.1:1 & 9.8:1	10"	87:1	Two-way w/neutral	20' x 7/16"	N/A	20' x 2"	3/8" x 2-3/4" grade 5	1"	1619-01***	6817	NO	N/A	Bulk
T2025 0301	2,000	4.1:1 & 9.8:1	10"	64:1	Two-way w/neutral	N/A	50' x 7/32"	N/A	Cable only	1-3/4"	NO	6817	N/A	NO	Bulk
T2605 0101	2,600	5.1:1 & 12.2:1	10"	108:1	Two-way w/neutral	24' x 7/16"	N/A	N/A	N/A	1"	1619-01***	6817	N/A	N/A	Litho Box
T2605 0301	2,600	5.1:1 & 12.2:1	10"	108:1	Two-way w/neutral	24' x 7/16"	N/A	N/A	N/A	1"	1619-01***	6817	N/A	N/A	Bulk
T2605Z0101	2,600	5.1:1 & 12.2:1	10"	108:1	Two-way w/neutral	N/A	N/A	20' x 2"	3/8" x 2-3/4" grade 5	1"	1619-01***	6817	YES	N/A	Litho Box
T2605Z0301	2,600	5.1:1 & 12.2:1	10"	108:1	Two-way w/neutral	N/A	N/A	20' x 2"	3/8" x 2-3/4" grade 5	1"	1619-01***	6817	YES	N/A	Bulk
XL26ZB301	2,600	5.1:1 & 12.2:1	10"	108:1	Two-way w/neutral	N/A	N/A	20' x 2"	3/8" x 2-3/4" grade 5	1"	1619-01***	6817	YES	N/A	Bulk
T2605B0101	2,600	5.1:1 & 12.2:1	10"	108:1	Two-way w/neutral	24' x 7/16"	N/A	N/A	N/A	1"	Installed	6817	N/A	N/A	Litho Box
T2605B0301	2,600	5.1:1 & 12.2:1	10"	108:1	Two-way w/neutral	24' x 7/16"	N/A	N/A	N/A	1"	Installed	6817	N/A	N/A	Bulk
T2605S0301	2,600	5.1:1 & 12.2:1	10"	108:1	Two-way w/neutral	24' x 7/16"	N/A	20' x 2"	3/8" x 2-3/4" grade 5	1"	1619-01***	6817	NO	N/A	Bulk
T2625 0101	2,600	5.1:1 & 12.2:1	10"	79:1	Two-way w/neutral	N/A	100' x 7/32"	N/A	Cable only	1-3/4"	1619-01***	6817	N/A	NO	Litho Box
T2625 0301	2,600	5.1:1 & 12.2:1	10"	79:1	Two-way w/neutral	N/A	100' x 7/32"	N/A	Cable only	1-3/4"	1619-01***	6817	N/A	NO	Bulk
T3205 0101	3,200	5.1:1 & 12.2:1	10"	79:1	Two-way w/neutral	N/A	100' x 7/32"	N/A	Cable only	1-3/4"	1619-01***	6817	N/A	NO	Litho Box
T3205 0301	3,200	5.1:1 & 12.2:1	10"	79:1	Two-way w/neutral	N/A	100' x 7/32"	N/A	Cable only	1-3/4"	1619-01***	6817	N/A	NO	Bulk
XL23ZB301	3,200	5.1:1 & 12.2:1	10"	79:1	Two-way w/neutral	N/A	N/A	20' x 2"	3/8" x 2-3/4" grade 5	1"	1619-01***	6817	YES	N/A	Bulk
T3205B0101	3,200	5.1:1 & 12.2:1	10"	79:1	Two-way w/neutral	N/A	100' x 7/32"	N/A	Cable only	1-3/4"	Installed	6817	N/A	NO	Litho Box
T32ZHD0301	3,200	5.1:1 & 12.2:1	10"	108:1	Two-way w/neutral	N/A	N/A	20' x 2"	3/8" x 2-3/4" grade 5	1"	Installed	6817	YES	N/A	Bulk
T3700 0101	3,700	5.1:1 & 12.2:1	10"	102:1	Two-way	N/A	90' x 7/32"	N/A	Cable only	1-3/4"	Included	9235	N/A	NO	Litho Box
T3700 0301	3,700	5.1:1 & 12.2:1	10"	102:1	Two-way	N/A	90' x 7/32"	N/A	Cable only	1-3/4"	Included	9235	N/A	NO	Bulk

The "S" version winches have a narrower drum to accommodate a 2" wide strap. **CE** All Cequent Performance Products two speed trailer winches are **CE** compliant. ** Maximum Mechanical Advance - Based on first layer of recommended line on the drum. For maximum efficiency, use only the amount of line required. *** Brake Kit 1619-01 available as option not furnished. Only winches that are shown to accommodate steel cable should be used with steel cable. Cable keeper kits are included with the winches specifying steel cable. Winches rated for steel cable have a larger drum hub to reduce or lessen chance of kinking or fraying.

Notes:

- Winch mounting hardware sold separately. Refer to instruction sheet for recommended bolt size and grade.
- Fulton brand two-speed winches are designed for boat trailer and other pulling applications, which require the freewheeling feature of ratchet type winches. If moving loads requiring vertical lifting, or positive load control in both directions, choose a Fulton brake winch.
- All Fulton brand winches are rated on the first layer of recommended rope, strap, or cable. The winch load capacity must be derated as additional layers are used. Derate the capacity 10% per additional layer of rope, strap, or cable.
- Fulton brand winches are NOT designed to be human hoists and should never be operated when there are persons on, around, or under the load being moved.

FULTON

BRAKE WINCHES

Fulton brand K-Series self-activating automatic brake winches hold the load securely when the crank handle is released. Typical applications include boat lifts, grain augers, manual fork lifts, retractable swing keels, dumpster lid lifts, and manual hoists. Drum hubs are 10 times the recommended cable size to maximize cable life. The KX series offer plated gear covers for improved gear train protection and a dual ratchet system.

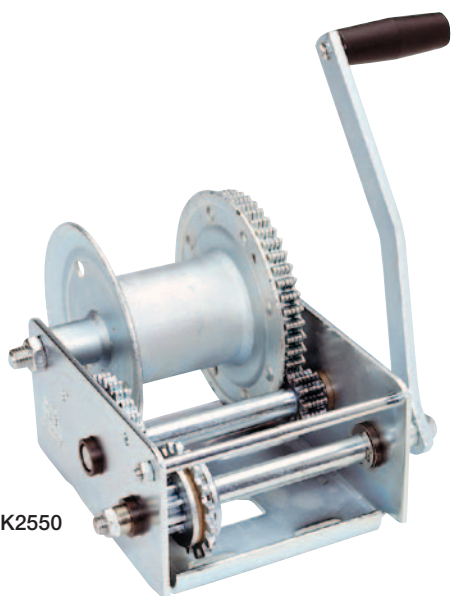

K2550

CE Compliant



K650

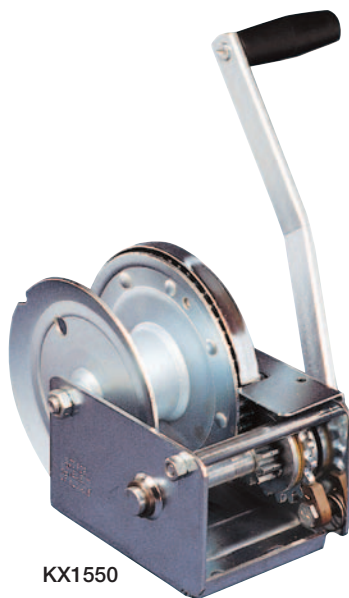

KX1550



K1051

BRAKE WINCHES

Part No.	Max. Rated Line Pull		Max. Cable Size Data (7 x 19 Galvanized Aircraft Cable)			Mechanical Data					
	1st Layer	Full Drum	Diameter	Drum Storage	Test Strength	Gear Ratio	Handle Length	Drum Hub Dia.	Free Wheel	Cable Included	Packaging
K650 0101	600 lbs. 272 kg	200 lbs. 91 kg	1/8" (3.2 mm)	85 ft. 26 m	2,000 lbs. 907 kg	1:01	11" 27.9 cm	1-1/4" 32 mm	NO	NO	Litho Box
K650 0301	600 lbs. 272 kg	200 lbs. 91 kg	1/8" (3.2 mm)	85 ft. 26 m	2,000 lbs. 907 kg	1:01	11" 27.9 cm	1-1/4" 32 mm	NO	NO	Bulk
K1051 0101	1,000 lbs. 454 kg	500 lbs. 227 kg	7/32" (5.5 mm)	50 ft. 15 m	5,600 lbs. 2540 kg	4.1:1	11" 27.9 cm	2-1/4" 57 mm	NO	NO	Litho Box
K1051 0301	1,000 lbs. 454 kg	500 lbs. 227 kg	7/32" (5.5 mm)	50 ft. 15 m	5,600 lbs. 2540 kg	4.1:1	11" 27.9 cm	2-1/4" 57 mm	NO	NO	Bulk
KX10510101	1,000 lbs. 454 kg	500 lbs. 227 kg	7/32" (5.5 mm)	50 ft. 15 m	5,600 lbs. 2540 kg	4.1:1	11" 27.9 cm	2-1/4" 57 mm	NO	NO	Ind. Box
KX10510301	1,000 lbs. 454 kg	500 lbs. 227 kg	7/32" (5.5 mm)	50 ft. 15 m	5,600 lbs. 2540 kg	4.1:1	11" 27.9 cm	2-1/4" 57 mm	NO	NO	Bulk
K1550 0101	1,500 lbs. 680 kg	700 lbs. 318 kg	1/4" (6 mm)	70 ft. 21 m	7,000 lbs. 3175 kg	5.1:1	11" 27.9 cm	2-1/2" 63 mm	NO	NO	Litho Box
K1550 0301	1,500 lbs. 680 kg	700 lbs. 318 kg	1/4" (6 mm)	70 ft. 21 m	7,000 lbs. 3175 kg	5.1:1	11" 27.9 cm	2-1/2" 63 mm	NO	NO	Bulk
KX15500101	1,500 lbs. 680 kg	700 lbs. 318 kg	1/4" (6 mm)	70 ft. 21 m	7,000 lbs. 3175 kg	5.1:1	11" 27.9 cm	2-1/2" 63 mm	NO	NO	Ind. Box
KX15500301	1,500 lbs. 680 kg	700 lbs. 318 kg	1/4" (6 mm)	70 ft. 21 m	7,000 lbs. 3175 kg	5.1:1	11" 27.9 cm	2-1/2" 63 mm	NO	NO	Bulk
KX20000301	2,000 lbs. 900 kg		1/4" (6 mm)	75 ft. 22.5 m		4.1:1	11" 27.9 cm	2"	NO	NO	Bulk
K2550 0101	2,500 lbs. 1134 kg	1,500 lbs. 680 kg	5/16" (8 mm)	70 ft. 21 m	9,800 lbs. 4445 kg	15.8:1	11" 27.9 cm	3-1/8" 79 mm	NO	NO	Litho Box
K2550 0301	2,500 lbs. 1134 kg	1,500 lbs. 680 kg	5/16" (8 mm)	70 ft. 21 m	9,800 lbs. 4445 kg	15.8:1	11" 27.9 cm	3-1/8" 79 mm	NO	NO	Bulk

Only winches that are shown to accommodate steel cable should be used with steel cable. Cable keeper kits are included with the winches specifying steel cable. Winches rated for steel cable have a larger drum hub to reduce or lessen chance of kinking or fraying.

CE All Cequent Performance Products brake winches are **CE** compliant.

Notes:

1. Fulton brand brake winches meet ASAE S361:3 standards (with the exception of the KX2000).
2. Winch mounting hardware sold separately. Refer to instruction sheet for recommended bolt size and grade.
3. All Fulton brand winches are rated on the first layer of recommended rope, strap, or cable. The winch must be derated as additional layers are used. Derate the capacity 10% per additional layer of rope, strap, or cable.
4. Fulton brand winches are NOT designed to be human hoists and should never be operated when there are persons on, around, or under the load being moved.

DIMENSIONAL INFORMATION

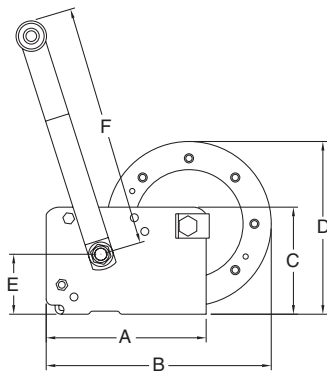

Model	A	B	C	D	E	F
K650	5.50"	5.50"	4.25"	5.56"	2.94"	11.00"
K/KX1051	5.25"	7.46"	3.69"	5.89"	1.90"	11.00"
K/KX1550	6.56"	9.23"	4.39"	7.08"	2.46"	11.00"
K2550	8.63"	11.13"	5.60"	7.13"	2.08"	11.00"

Contact Cequent Representative for mounting hole information.



KR15000301



BRAKE WINCHES

- Self Activating Automatic Brake
- Passes all applicable SAE and ASAE standards
- Enlarged drum size to extend cable life
- Solid Gear construction
- Covered Braking System
- CE Compliant

BRAKE WINCHES

Part No.	Capacity	Gear Ratio	Cable Capacity	Cable included	Packaging
KR10000301	1,000 lbs.	3.5:1	50 ft., 7/32" Dia.	NO	Boxed
KR15000301	1,500 lbs.	5.1:1	50 ft., 7/32" Dia.	NO	Boxed



KW3000

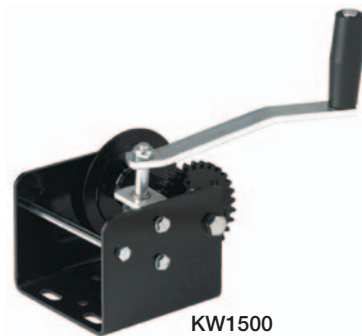

KW1500



WORM GEAR WINCHES

Fulton brand worm gear winches feature high gear ratios for excellent load control. Worm gear design allows reel to automatically stop when handles are released. No minimum loading is required for winch operation. Drum hubs are sized to prevent cable damage and extend cable life. Oil-impregnated bushings and comfort grip handles for easy cranking. Reinforced frames keep gears aligned for improved life cycle performance.

WORM GEAR WINCHES

Part No.	Capacity	Description	Gear Ratio	Drum Cable Storage				Drum Diameter	Drive
				1/8" (3.2 mm)	3/16" (4.8 mm)	1/4" (6.5 mm)	5/16" (7.9 mm)		
KW15000103	1,500 lbs. 680 kg	Regular drum Handle drive	31:1	115' (35 m)	50' (15 m)	—	—	1.5" (38.1 mm)	8" handle (20.3cm)
KW20000103	2,000 lbs. 907 kg	Regular drum Handle drive	31:1	235' (71 m)	100' (30 m)	—	—	1.5" (38.1 mm)	8" handle (20.3cm)
KW30000103	3,000 lbs. 1,361 kg	Regular drum Driving ring and handle	31:1	—	160' (48 m)	90' (27 m)	60' (18 m)	3.125" (79.4 mm)	Drive ring 10" handle (25.4 cm)

Notes:

1. Winch mounting hardware sold separately. Refer to instruction sheet for recommended bolt size and grade.
2. All Fulton brand winches are rated on the first layer of recommended rope, strap, or cable. The winch must be derated as additional layers are used. Derate the capacity 10% per additional layer of rope, strap, or cable.
3. Fulton brand winches are NOT designed to be human hoists and should never be operated when there are persons on, around, or under the load being moved.



WS20 / WSP12



WC325



WS20HD0600

WINCH ACCESSORIES

Part No.	Description	Packaging
WS20 0200	Winch Strap and Hook - Nylon web winch strap with hook, 2" x 20', 2,600 lb. maximum working load	Bulk
WS20 0700	Winch Strap and Hook - Nylon web winch strap with hook, 2" x 20', 2,600 lb. maximum working load	Clam Shell
WS20DP0200	Winch Strap and Hook - Nylon web winch strap with hook, 2" x 20', 2,600 lb. maximum working load	Counter Display Box
WSP12 0100	Personal Watercraft Winch Strap with Hook and Loop - includes loop Nylon web winch strap with hook, 2" x 12', 1,800 lb. maximum working load	Clam Shell
WSP12 0200	Personal Watercraft Winch Strap with Hook and Loop - includes loop Nylon web winch strap with hook, 2" x 12', 1,800 lb. maximum working load	Bulk
WSP12D0200	Personal Watercraft Winch Strap with Hook and Loop - includes loop Nylon web winch strap with hook, 2" x 12', 1,800 lb. maximum working load	Counter Display Box
WS20HD0200	Heavy Duty Winch Strap and Hook - 2" x 20', 10,000 lb. minimum breaking strength, 4,000 lb. maximum working load	Bulk
WS20HD0600	Heavy Duty Winch Strap and Hook - 2" x 20', 10,000 lb. minimum breaking strength, 4,000 lb. maximum working load	Clam Shell
WC325 0100	Winch Cable and Hook - 3/16" x 25' galvanized cable, 4,200 lb. breaking strength	Clam Shell
WC750 0100	Winch Cable and Hook - 7/32" x 50' galvanized cable, 5,600 lb. breaking strength	Clam Shell

WINCH REPAIR PARTS / SERVICE KITS

Part No.	Description	Packaging
0133301S00	Service Kit, Ratchet Repair - XLT14	Bagged
0133302S00	Service Kit, Pinion Shaft - XLT14	Bagged
0133303S01	Service Kit, Pinion Shaft - T1602, T1801	Bagged
0133306S01	Service Kit, Ratchet Repair - T1100, T1300, T1500	Bagged
1514S01	Service Kit, One Way Ratchet Repair - T600, T600L, T900 - Models Pre-2007	Bagged
1558S00	Service Kit, Friction Disc - K/KX1550	Bagged
1562S00	Service Kit, Ratchet Repair, 2-Speed - T2005, T2605(B), T2625, T3205	Bagged
1563S01	Service Kit, Pinion Shaft - K/KX1550	Bagged
1565S01	Service Kit, Pinion Shaft/Gear - K2550	Bagged
1568S01	Service Kit, Inter Shaft - K2550	Bagged
1570S00	Service Kit, Friction/Brake Disc - K/KX1051	Bagged
1598S01	Service Kit, Ratchet Repair - T1602, T1801, T903Z, P1200	Bagged
1609S01	Service Kit, Input Shaft/Bearing - T2005, T2605(B), T2625, T3205	Bagged
1619-01	Service Kit, 2-Speed Brake	Bagged
2461P01	Winch Handle, 11" Offset Packaged	Carded
4197S00	Service Kit, Ratchet Repair - T2000, T2500, T3700	Bagged
4769-28	Ratchet Spring, 2-Speed	Bagged
5621P01	Service Kit, Cable Keeper - K/KX1051, K/KX1550, KX1575, K2550	Clam Shell
5868P01	Winch Handle, 6" Offset Packaged	Carded
6302P01	Winch Handle, 8" Offset Packaged	Carded
6312P01	Winch Handle, 7" Offset Packaged	Carded
6730S00	Service Kit, Ratchet Repair - K/KX1550	Bagged
6731S00	Service Kit, Ratchet Repair - K/KX1051	Bagged
6817P01	Winch Handle, 10" Offset Packaged	Carded
9235P01	Winch Handle, 10" Dogleg Packaged	Carded

TIPS TO LIGHT UP YOUR LIFESTYLE

Do I have to use a light or can I use a reflector instead?

Lighting and conspicuity requirements are governed by FMVSS & CMVSS 108. Their use is determined by safety and identification requirements.

What regulations apply to the lighting of a trailer or motor coach? In the USA, FMVSS 108, www.nhtsa.dot.gov. In Canada, CMVSS 108 is used. www.tc.gc.ca.

Why use LED and not Incandescent? The key difference is the way both technologies operate. While both technologies are an acceptable means for vehicle lighting, LED is the stronger technology in Energy Efficiency, Light Output, Reliability, Safety and Life Expectancy.

Do LED lights have to be mounted differently than Incandescent? No, the FMVSS/CMVSS 108 mounting requirements are the same.

When retrofitting a Bargman 59 or 84/85/86 Series Incandescent light with LED can the old lenses be reused? No, Bargman® 59 & 84/85/86 Series LED upgrade kits come with pre-assembled lenses and a simple "plug & play" replacement design.

What does stop/tail/turn mean? How many lights do I need to use to achieve it? Are they the same as "Tail Lights"? Stop/Tail/Turn is a combination rating meaning a specific light or grouping of lights in an assembly meet the requirements for this named combination. This rating can be achieved using 1 light alone as long as the light source meets the requirements for the specific application.

Why does Cequent offer so many different types & styles of lights for a vehicle? Cequent is never satisfied with the status quo and is continually striving to design lights that will meet the designated federal requirements and fit our customer's specific application needs.

When using a Multi-Function Stop/Tail/Turn Light, is a Backup Light function required and does it matter where the Backup Light is located? The requirement for and location of the Backup Light is determined by vehicle type and FMVSS/CMVSS 108 requirements.

Why are some Turn Signal Lights Red and others Amber, does it matter which color I use? Yes, the color does matter. While both colors are acceptable for turn signals, the color use is primarily driven by the "Stop" Function. When using a multi-function Stop/Turn light, the color must be Red as required by FMVSS/ CMVSS 108 requirements.

What does "Over" or "Under" 80 refer to? This is a reference to a vehicles width in inches. There are differing FMVSS/CMVSS 108 requirements covering this dimensional reference point.

What are "Over 80" Combination Tail Lights?

These units meet seven or eight lighting requirements as defined by FMVSS/CMVSS 108.

What are "Under 80" Combination Tail Lights? These units meet six or seven lighting requirements as defined by FMVSS/CMVSS 108.

What is the difference between Side Marker & Clearance Lights? Side Marker Lights are mounted on the side of a vehicle and are used to define its length. Clearance Lights are mounted on the front and rear of a vehicle and are used to define its width.

What are "PC" Side Marker/Clearance Lights?

These lights meet the FMVSS/CMVSS 108 requirements for photometric certification as both Clearance and Side Marker Lights when properly mounted.

The  symbol is for Wet Location Lights. **What does it mean?** Wet Location Lighting products in this catalog are either: "Waterproof/Sealed" or "Submersible" and are safe to use on marine and other trailers that will be in and around the water or UL listed as suitable for wet location use.

What are Submersible Lights? Submersible lights purposely allow water to enter the light assembly, however a cushion of air forms when water enters the light and will protect the bulbs and electrical connectivity from damage. This natural phenomenon is known as the "Bell Jar Principle". These lights are ideal for boat trailers and utility trailers that will be submersed in water.

What are Waterproof/Sealed Lights? "Waterproof" and "sealed" mean exactly the same - these lights are completely sealed and will not allow water to enter the inside of the light assembly. Many of our new LED Side/Marker and Tail Lights are completely sealed as to prevent water from damaging the circuit board and components associated with LED Technology.

Why are vehicle lights grounded? Vehicle lights are grounded in order to complete the electrical circuit. There are differing ways to ground them to meet various applications.

What is an ID Bar, and can one be used as a multi-function Stop/Tail/Turn as well? An ID Bar is an Identification Bar. It consists of 3 lights and is required in order to identify the rear center location on over 80" vehicles. They May Not be used as Multi-Function Lights.

EXTERIOR LIGHTING

- LED Tail Lights
- Waterproof LED Tail Lights
- Submersible LED Tail Lights
- Single Tail Lights / Wrap-Around Clearance / Side Marker
- Recessed Tail Lights
- Surface Mount Tail Lights
- Combination Tail Lights
- Waterproof / Sealed Recessed Tail Lights
- Waterproof Tail Lights
- Submersible Tail Lights
- Waterproof Auxiliary / Auxiliary Lights
- AG Lighting / Accessories
- LED Clearance / Side Marker Lights
- Waterproof / Sealed Clearance / Side Marker Lights
- Standard Clearance / Side Marker Lights
- Dual Bulb Clearance / Side Marker Lights
- LED ID Light Bars
- Waterproof ID Light Bars
- ID Light Bars & Center High Mount Stop Lamp (CHMSL)
- License Plate Lights / Brackets
- Reflectors
- Porch / Utility Lights / Assist Bars

INTERIOR LIGHTS

- Interior Lights

PLANOGRAMS

- Wesbar® LED/Incandescent Lighting/Electrical
- Bargman® LED/Incandescent Lighting

TECHNICAL

- Technical - Bulb Specification
- Technical - Federal Lighting Requirements
- Technical - AG Lighting



NOTE: Tail Lights, Clearance/Side Marker Lights and ID Light Bars approved for trailer accessory and towing application use. Contact your Cequent Performance Products Representative for details.



LED UPGRADE KITS #84/85/86 SERIES TAIL LIGHTS

Quick and simple LED upgrade kit for existing #84 series tail lights. Remove the bulb and lens, replace with new LED module and instantly have LED red stop/tail/turn lights, amber turn lights, clear backup lights or clear backup w/reflex lights. Installation can be completed in minutes with only a screwdriver required.



Bargman/Wesbar Bulk	Bargman Clam Shell	Bargman Bagged	Wesbar Packaging	Description
	42-84-410	47-84-410		LED Stop/Tail/Turn Light Lens Module Red w/ Bulb Socket Plug
	42-84-412	47-84-412		LED Turn Light Lens Module Amber w/Bulb Socket Plug
	42-84-414	47-84-414		LED Backup Light Lens Module Red Reflex w/ Clear Center w/Bulb Socket Plug
47-84-026	42-84-415			LED Backup Light Lens Module Clear w/Bulb Socket Plug - Lens Mounted Vertical

Incandescent Upgrade Lens #84/85/86 Series Tail Lights - Backup (or Red w/Red insert) Lens Only

47-84-711		48-84-711		Enhanced Height Incandescent Backup Lens Only - Red Reflex w/Clear Center - Red Border
47-85-711		48-85-711		Enhanced Height Incandescent Backup Lens Only - Red Reflex w/Clear Center - Chrome Border
47-84-712		48-84-712		Enhanced Height Incandescent Lens Only - Red Reflex w/Red Center - Red Border
47-85-712		48-85-712		Enhanced Height Incandescent Lens Only - Red Reflex w/Red Center - Chrome Border

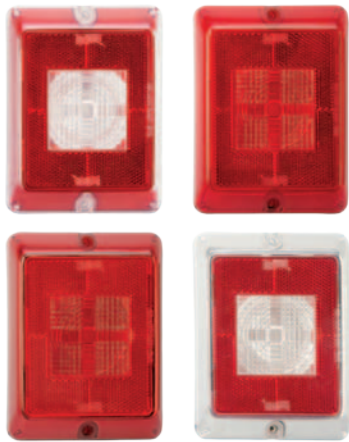

Existing Incandescent Backup (or Red w/Red Insert) Lens

Enhanced Height Incandescent Backup (or Red w/Red Insert) Lens Installed



LED Upgrade Lens

LED Upgrade Lens

LED UPGRADE KITS #86 SERIES WRAP-AROUND CLEARANCE/SIDE MARKER LIGHTS

Quick and simple LED upgrade kit for existing #86 series wrap-around clearance/side marker lights. Remove and discard only the wedge base socket and bulb, replace with a new LED module and instantly have LED clearance/side marker lights.



Bargman/Wesbar Bulk	Bargman Clam Shell	Bargman Bagged	Wesbar Packaging	Description
	42-86-410	47-86-410		LED Wrap-Around Clearance Light Module Red
	42-86-412	47-86-412		LED Wrap-Around Clearance Light Module Amber

BARGMAN #84/85/86 LED LIGHTS

LED Tail Lights and Upgrade Kits for the most popular RV Tail Light in the World! Purchase as fully-assembled complete tail lights for installation or purchase a LED Module Upgrade Kit. The Upgrade Kit will allow you to quickly and easily field upgrade your installed Bargman Model #84/85/86 Tail Lights or Model #86 Wrap-Around Marker/Clearance lights from Incandescent to LED.

HOW TO ORDER

Fully assembled units:

Fully assembled LED versions of the Bargman #84/85/86 tail lights and #86 wrap-around clearance/side marker lights are listed. For convenience and consistency, we have listed them in the same manner that we list the incandescent models. Please note that the part numbers for all LED versions begin with 42/47/48-

Upgrade kits:

These kits are designed to allow RV and Trailer owners to upgrade their Bargman #84/85/86 Tail Lights or #86 Wrap-Around Marker/Clearance lights from Incandescent to LED - quickly and safely. Due to the many configurations of these Bargman light models, upgrade kits are sold to upgrade only one module at a time.

WARNING: All Bargman #84/85/86 Tail Lights and #86 Wrap-Around Marker/Clearance lights meet FMVSS/CMVSS 108 requirements. **WHEN UPGRADING EXISTING LIGHTS FROM INCANDESCENT TO LED, TO RETAIN FMVSS/ CMVSS 108 REQUIREMENTS, SPECIAL CARE MUST BE GIVEN TO REPLACE EXISTING LENS (OR TO ASSEMBLE MODULE) WITH A LED MODULE THAT WILL PERFORM THE EXACT SAME FUNCTION.**

NOTE: For regulatory purposes, installation of any competitive LED Upgrade Kit designed for the Bargman #84/85/86 Tail Lights will immediately void all warranty on the entire Bargman tail light.

#84 Series Tail Lights LED Upgrade Kits

The end-user will simply count the number of red stop/tail/turn lights, amber turn lights or backup lights on the vehicle and order the appropriate number of the desired LED upgrade kits. The end user will simply remove the incandescent lens and bulb and plug the LED module (LED circuit board with connector and lens) into the existing bulb socket and mount, with the existing screws, to the holes in the existing light base.

#86 Series Marker Light LED Upgrade Kit

The end-user will simply count the number of wrap-around clearance/side marker lights on the vehicle and order the appropriate number of the desired LED upgrade kits. The end user will simply remove the lens and bulb and plug the LED module (LED circuit board) into the existing bulb socket and re-install the existing lens.



LED WRAP-AROUND CLEARANCE/SIDE MARKER LIGHTS #86 SERIES

This 90 degree LED wrap-around light meets lighting requirements for side markers and clearance lights and doubles as a Class "A" side-reflex reflector. The light meets FMVSS/CMVSS 108 requirements.
5 3/4" X 4 3/8" X 2 3/16"



Bargman/Wesbar Bulk	Bargman Clam Shell	Bargman Bagged	Wesbar Packaging	Description
47-86-005				LED Wrap-Around Clearance Light Red w/ Colonial White Base
47-86-202		48-86-202		LED Wrap-Around Clearance Light Red w/Black Base
47-86-006				LED Wrap-Around Clearance Light Amber w/ Colonial White Base
47-86-203		48-86-203		LED Wrap-Around Clearance Light Amber w/ Black Base

Replacement Parts

	42-86-410	47-86-410		LED Wrap-Around Clearance Light Module Red
	42-86-412	47-86-412		LED Wrap-Around Clearance Light Module Amber
30-86-711		34-86-711		Lens #86 Red Wrap-Around
30-86-712		34-86-712		Lens #86 Amber Wrap-Around
30-84-075				Marker Light Lens Screw

LED SINGLE TAIL LIGHTS #86 SERIES

These LED lights meet FMVSS/CMVSS 108 requirements. Bases are available in either white or black. All include 16 gauge supply and ground wiring.
5 13/16" X 4 3/8" X 2 7/8"



Bargman/Wesbar Bulk	Bargman Clam Shell	Bargman Bagged	Wesbar Packaging	Description
47-86-001				LED Stop/Tail/Turn w/Colonial White Base
47-86-101	42-86-101	48-86-101		LED Stop/Tail/Turn w/Black Base
47-86-004				LED Turn Amber w/Colonial White Base
47-86-104	42-86-104	48-86-104		LED Turn Amber w/Black Base

Replacement Parts

		47-84-420		LED Stop/Tail/Turn Light Lens Module Red w/Wires
		47-84-422		LED Turn Light Lens Module Amber w/Wires

NOTE: Tail Lights, Clearance/Side Marker Lights and ID Light Bars approved for trailer accessory and towing application use. Contact your Cequent Performance Products Representative for details.



LED SURFACE MOUNT DOUBLE TAIL LIGHTS
#84 SERIES / #85 SERIES

These LED double lights are available for surface mounting in vertical or horizontal applications. Stylish bases with radius corners come in either black or chrome plated finish. All lenses meet FMVSS/CMVSS 108 requirements. Reflex is included on backup lens. Prewired (supply and ground) for easy installation.
 10 1/4" x 7 1/4" x 1 7/8".



Bargman/Wesbar Bulk	Bargman Clam Shell	Bargman Bagged	Wesbar Packaging	Description
47-84-613				LED Red Stop/Tail/Turn, LED Backup w/Black Base
47-85-614				LED Red Stop/Tail/Turn, LED Backup w/Chrome Base
47-84-612				LED Red Stop/Tail/Turn, LED Amber Turn w/Black Base
47-85-615				LED Red Stop/Tail/Turn, LED Amber Turn w/Chrome Base
47-84-610				LED Red Stop/Tail/Turn, LED Red Stop/Tail/Turn w/Black Base
47-85-611				LED Red Stop/Tail/Turn, LED Red Stop/Tail/Turn w/Chrome Base

Replacement Parts

		47-84-420		LED Stop/Tail/Turn Light Lens Module Red w/Wires
		47-84-422		LED Turn Light Lens Module Amber w/Wires
		47-84-424		LED Backup Light Lens Module Clear w/Wires

LED RECESSED DOUBLE TAIL LIGHTS
#84 SERIES / #85 SERIES

LED double lights for either vertical or horizontal mounting. Radius corners. Black, white and colonial white bases. Clear LED or incandescent backup light lenses are surrounded by a Class "A" red reflex lens. Incandescent lens, red w/red insert, is for clearance/side marker application only. All lenses meet FMVSS/CMVSS 108 requirements. Prewired (supply and ground) for easy installation.
 Cutout: 8 7/16" X 5 1/2", Overall: 9 13/16" X 6 15/16" X 1 1/4" w/ 1" depth



Bargman/Wesbar Bulk	Bargman Clam Shell	Bargman Bagged	Wesbar Packaging	Description
47-84-546				LED Red Stop/Tail/Turn, LED Amber Turn w/White Base
47-84-518				LED Red Stop/Tail/Turn, LED Amber Turn w/Black Base
47-84-527		48-84-527		LED Red Stop/Tail/Turn, LED Red Stop/Tail/Turn w/Black Base
47-84-001				LED Red Stop/Tail/Turn, Incandescent Backup w/Colonial White Base
47-84-540				LED Red Stop/Tail/Turn, Incandescent Backup w/White Base
47-84-008		48-84-008		LED Red Stop/Tail/Turn, Incandescent Backup w/Black Base
47-84-529		48-84-529		LED Red Stop/Tail/Turn, Incandescent Red w/Red Insert (Clearance/Side Marker Application Only) w/Black Base

Replacement Parts

		47-84-420		LED Stop/Tail/Turn Light Lens Module Red w/Wires
		47-84-422		LED Turn Light Lens Module Amber w/Wires
47-84-711		48-84-711		Enhanced Height Incandescent Backup Lens Only - Red Reflex w/Clear Center - Red Border
47-84-712		48-84-712		Enhanced Height Incandescent Lens Only - Red Reflex w/Red Center - Red Border

NOTE: Tail Lights, Clearance/Side Marker Lights and ID Light Bars approved for trailer accessory and towing application use. Contact your Cequent Performance Products Representative for details.



LED RECESSED TRIPLE TAIL LIGHTS #84 SERIES/#85 SERIES

LED triple lights for either vertical or horizontal mounting. Radius corners. Bases in black, white, colonial white and chrome plated finish. Clear LED or incandescent backup light lenses surrounded by a Class "A" red reflex lens. Incandescent lens, red w/red insert, for clearance/side marker application only. Lenses meet FMVSS/CMVSS 108 requirements. Prewired (supply and ground) for easy installation.

Cutout: 12 11/16" X 5 1/2", Overall: 14 1/16" X 6 15/16" X 1 1/4" w/ 1" depth



Bargman/Wesbar Bulk	Bargman Clam Shell	Bargman Bagged	Wesbar Packaging	Description
47-84-002				LED Red, LED Red Stop/Tail/Turn, Incandescent Backup w/Colonial White Base
47-84-530				LED Red, LED Red Stop/Tail/Turn, Incandescent Backup w/White Base
47-84-009		48-84-009		LED Red, LED Red Stop/Tail/Turn, Incandescent Backup w/Black Base
47-85-002				LED Red, LED Red Stop/Tail/Turn, Incandescent Backup w/Chrome Base
47-84-522				LED Red Stop/Tail/Turn, Incandescent Backup, LED Red Stop/Tail/Turn w/Black Base
47-84-003				LED Red Stop/Tail/Turn, LED Amber Turn, Incandescent Backup w/Colonial White Base
47-84-005				LED Red Stop/Tail/Turn, LED Amber Turn, Incandescent Backup w/Black Base
47-85-004				LED Red Stop/Tail/Turn, LED Amber Turn, Incandescent Backup w/Chrome Base
47-85-005				LED Red, LED Red Stop/Tail/Turn, Incandescent Red w/Red Insert (Clearance/Side Marker Application Only) w/Chrome Base

Replacement Parts

		47-84-420		LED Stop/Tail/Turn Lens Module Red w/Wires
		47-84-422		LED Turn Light Lens Module Amber w/Wires
47-84-711		48-84-711		Enhanced Height Incandescent Backup Lens Only - Red Reflex w/Clear Center - Red Border
47-84-712		48-84-712		Enhanced Height Incandescent Lens Only - Red Reflex w/Red Center - Red Border

LED RECESSED TRIPLE LONG TAIL LIGHTS #84 SERIES / #85 SERIES

This series of LED triple tail lights incorporates all of the features of the LED Recessed Triple Tail Light #84 Series/ #85 Series with a special lens placement that allows the light to be utilized for a narrow mounting.

Cutout: 16 1/8" X 3 5/8", Overall: 18" X 5 5/16" X 1 1/4" w/ 1" depth



Bargman/Wesbar Bulk	Bargman Clam Shell	Bargman Bagged	Wesbar Packaging	Description
47-84-101				LED Red Stop/Tail/Turn, Incandescent Backup, LED Red Stop/Tail/Turn w/Colonial White Base
47-84-555				LED Red Stop/Tail/Turn, Incandescent Backup, LED Red Stop/Tail/Turn w/White Base
47-84-103				LED Red Stop/Tail/Turn, Incandescent Backup, LED Red Stop/Tail/Turn w/Black Base
47-84-104				LED Red Stop/Tail/Turn, Incandescent Backup, LED Amber Turn w/Black Base

Replacement Parts

		47-84-420		LED Stop/Tail/Turn Lens Module Red w/Wires
		47-84-422		LED Turn Light Lens Module Amber w/Wires
47-84-711		48-84-711		Enhanced Height Incandescent Backup Lens Only - Red Reflex w/Clear Center - Red Border
47-84-712		48-84-712		Enhanced Height Incandescent Lens Only - Red Reflex w/Red Center - Red Border

NOTE: Tail Lights, Clearance/Side Marker Lights and ID Light Bars approved for trailer accessory and towing application use. Contact your Cequent Performance Products Representative for details.



SURFACE MOUNT LED TAIL LIGHTS #07 SERIES

Combination stop, tail and turn lights feature LED technology with 16 diodes. Unprecedented design flexibility for vertical or horizontal applications, 8 different mounting combinations possible. These lights with radius styling feature a white base and snap-on lens. Prewired (supply and ground) for easy installation. Meet FMVSS/CMVSS 108 requirements (AIST 07 DOT). **NOTE: Units with license plate light and bracket approved for horizontal mounting only.**

8 7/16" x 5 15/16" x 2 5/16"



Bargman/Wesbar Bulk	Bargman Clam Shell	Bargman Bagged	Wesbar Packaging	Description
47-07-001				LED Stop/Tail/Turn Light Surface Mount #07 Series
47-07-002				LED Stop/Tail/Turn Light Surface/Horizontal Mount #07 Series w/License Light & Bracket
47-07-003				LED Stop/Tail/Turn Light Surface Mount #07 Series
47-07-100				LED Stop/Tail/Turn Light Surface/Horizontal Mount #07 Series w/License Light & Bracket

Replacement Parts

47-07-010				Lens for 47-07-001
47-07-011				Lens for 47-07-002
47-07-012				Lens for 47-07-003
47-07-013				Lens for 47-07-100

SURFACE MOUNT TAIL LIGHT #07 SERIES MOUNTING COMBINATIONS

Horizontal Mounting Combinations



Vertical Mounting Combinations





LED NARROW TAIL LIGHT #54 SERIES

This LED tail light with 3 diodes is designed for a narrow rail surface mounting. Features include built-in reflex reflectors and mounting holes with stainless steel grommets. This light meets FMVSS/CMVSS 108 requirements. Prewired (supply and ground) for easy installation.



15.84" x 2.29" - Mounting holes on 14.49" centers

Bargman/ Wesbar Bulk	Bargman Clam Shell	Bargman Bagged	Wesbar Packaging	Description
47-54-001				Red Stop/Tail/Turn

LED 6" OVAL MID-TURN LIGHT

Standard 6" grommet mount oval LED mid-turn light. Certified to SAE J914 for side turn signal. Meets FMVSS/CMVSS 108 requirements for intermediate side marker and side reflex on vehicles over 30 ft. long. Grommet and pigtail available separately.



6.48" x 2.30" x 2.71" overall height (2" depth w/pigtail, 1.35" height)

Bargman/ Wesbar Bulk	Bargman Clam Shell	Bargman Bagged	Wesbar Packaging	Description
47-06-005				6" Oval Mid-Turn Amber Light

Replacement Parts

40-00-003		44-00-003		3 Wire Pigtail w/12" Wire Lead
40-00-004			719063	3 Wire 90° Pigtail w/12" Wire Lead
40-06-020		44-06-020	416088	6" Oval Grommet
106205		34-108119	106873	6" Oval Mounting Bracket
			401591	6" Oval Grommet & 3 Wire 90° Pigtail

NOTE: Tail Lights, Clearance/Side Marker Lights and ID Light Bars approved for trailer accessory and towing application use. Contact your Cequent Performance Products Representative for details.



WATERPROOF LED OVER 80" 3X8 LOW PROFILE TAIL LIGHTS 

These waterproof lights meet FMVSS/CMVSS 108 requirements for trailers over 80" wide when properly mounted. Includes stainless steel mounting hardware. Includes 3-wire plug-in harness with 12" wire leads and 7" ring terminal ground. 8" x 2 7/8" x 2 3/4"



Bargman/Wesbar Bulk	Bargman Clam Shell	Bargman Bagged	Wesbar Packaging	Description
271574			407530	7-Function, Right/Curbside
271575			407535	8-Function, Left/Roadside

Kit comes complete with two low profile tail lights, 25' trailer wiring harness cable with molded 4-way plug, 4' four wire car wiring harness cable with molded 4-way plug and license plate bracket.



Bargman/Wesbar Bulk	Bargman Clam Shell	Bargman Bagged	Wesbar Packaging	Description
	31-407540		407540	Trailer Light Kit

Replacement Parts

40-00-004			719063	3 Wire 90° Pigtail w/12" Wire Lead
003201			003211	License Plate Bracket
002301			707275	4' Wiring Harness w/4-Way Flat Car End
108825			707261	25' Wiring Harness w/4-Way Flat Trailer End

WATERPROOF LED OVER 80" WRAP-AROUND TAIL LIGHTS 

Waterproof surface mount tail lights. Wrap-around design eliminates the need for rear side marker/reflector. These lights meet FMVSS/CMVSS 108 requirements. Plug-in 12" harness with 2-way flat connector and ring terminal ground wire. Stainless steel mounting hardware included.

7.53" x 3.48" x 3.13"



Bargman/Wesbar Bulk	Bargman Clam Shell	Bargman Bagged	Wesbar Packaging	Description
271594			281594	7-Function, Right/Curbside
271595			281595	8-Function, Left/Roadside

WATERPROOF LED 4" ROUND TAIL LIGHT 

Featuring LED Technology, this grommet light is waterproof and meets FMVSS/CMVSS 108 requirements.



Bargman/Wesbar Bulk	Bargman Clam Shell	Bargman Bagged	Wesbar Packaging	Description
		47-01-031		Red Stop/Tail/Turn Light w/Grommet w/Pigtail

Replacement Parts

47-01-001				Stop/Tail/Turn Light 4" Round Red
40-00-006				Pigtail
40-01-020		44-01-020		4" Round Grommet

NOTE: Tail Lights, Clearance/Side Marker Lights and ID Light Bars approved for trailer accessory and towing application use. Contact your Cequent Performance Products Representative for details.





WATERPROOF LED OVER 80" 4X6 LOW PROFILE TAIL LIGHTS

Unique, compact size and shape allows these waterproof lights to fit where space is limited. Meets FMVSS/CMVSS 108 requirements for trailers over 80" wide when properly mounted. Includes stainless steel mounting hardware.

6" x 3 1/2" x 2 1/4"



Bargman/Wesbar Bulk	Bargman Clam Shell	Bargman Bagged	Wesbar Packaging	Description
271584				7-Function, Right/Curbside
271584-01				7-Function, Right/Curbside w/3 Wire Pigtail
			407550	7-Function, Right/Curbside w/3 Wire 90° Pigtail
271585		34-271585		8-Function, Left/Roadside
271585-01				8-Function, Left/Roadside w/3 Wire Pigtail
			407555	8-Function, Left/Roadside w/3 Wire 90° Pigtail

Kit comes complete with two low profile tail lights, 25' trailer wiring harness cable with molded 4-way plug, 4' car wiring harness cable with molded 4-way plug and license plate bracket.

Bargman/Wesbar Bulk	Bargman Clam Shell	Bargman Bagged	Wesbar Packaging	Description
	31-407560		407560	Trailer Light Kit

Replacement Parts

40-00-003		44-00-003		3 Wire Pigtail w/12" Wire Lead
40-00-004			719063	3 Wire 90° Pigtail w/12" Wire Lead
003201			003211	License Plate Bracket
002301			707275	4' Wiring Harness w/4-Way Flat Car End
108825			707261	25' Wiring Harness w/4-Way Flat Trailer End

WATERPROOF LED 6" OVAL GROMMET MOUNT TAIL LIGHTS

Featuring LED Technology, these grommet mount lights are waterproof and meet FMVSS/CMVSS 108 requirements. Lights are mounting-orientation specific. Mounting bracket of 11 ga. steel available separately.

6 1/2" x 2 5/16" x 7/8"



Bargman/Wesbar Bulk	Bargman Clam Shell	Bargman Bagged	Wesbar Packaging	Description
		47-06-031		Red Stop/Tail/Turn Light Vertical Mount w/ Grommet w/90° Pigtail
		47-06-034		Red Stop/Tail/Turn Light Horizontal Mount w/ Grommet w/90° Pigtail

Replacement Parts

47-06-001		47-06-401	401563	Red Stop/Tail/Turn Light Vertical Mount
47-06-004		47-06-404	401584	Red Stop/Tail/Turn Light Horizontal Mount
40-00-003		44-00-003		3 Wire Pigtail w/12" Wire Lead
40-00-004			719063	3 Wire 90° Pigtail w/12" Wire Lead
40-06-020		44-06-020	416088	6" Oval Grommet
106205		34-108119	106873	6" Oval Mounting Bracket
			401591	6" Oval Grommet & 3 Wire 90° Pigtail

NOTE: Tail Lights, Clearance/Side Marker Lights and ID Light Bars approved for trailer accessory and towing application use. Contact your Cequent Performance Products Representative for details.

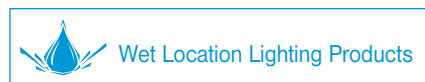



WATERPROOF LED 6" OVAL GROMMET MOUNT TAIL LIGHTS 

Featuring LED Technology, these grommet mount lights with 10 diodes are waterproof and meet FMVSS/CMVSS 108 requirements. Approved for vertical or horizontal mounting. Grommet, 3 prong wiring pigtail and 11 ga. steel mounting bracket available separately.
6.42" x 2.28" x 1"



Bargman/Wesbar Bulk	Bargman Clam Shell	Bargman Bagged	Wesbar Packaging	Description
			54006	Red Stop/Tail/Turn Light w/Grommet w/3 Wire 90° Pigtail
273561			283561	Red Stop/Tail/Turn Light
273564			283564	Amber Turn Light
273565			283565	White Backup Light

Accessory Parts

40-00-003		44-00-003		3 Wire Pigtail w/12" Wire Lead
40-00-004			719063	3 Wire 90° Pigtail w/12" Wire Lead
40-06-020		44-06-020	416088	6" Oval Grommet
106205		34-108119	106873	6" Oval Mounting Bracket
			401591	6" Oval Grommet & 3 Wire 90° Pigtail

WATERPROOF LED 6" OVAL SURFACE FLANGE MOUNT TAIL LIGHTS 

Featuring LED Technology, these flange mount lights are waterproof and meet FMVSS/CMVSS 108 requirements. Surface mounting with prewired supply and ring terminal ground for easy installation.



7.5" x 3.28" x .82"

Bargman/Wesbar Bulk	Bargman Clam Shell	Bargman Bagged	Wesbar Packaging	Description
			54004	Red Stop/Tail/turn w/Black Flange w/Chrome Trim Snap Ring
50-767751				Red Stop/Tail/Turn w/Black Flange
40-767758				Amber Turn w/Black Flange

Accessory Parts

85-767010				Chrome Trim Snap Ring
------------------	--	--	--	-----------------------

WATERPROOF LED 6" OVAL SURFACE FLANGE MOUNT CHMSL 

SAE U2 supplemental center high mounted stop lamp. 10 LED diode design. Tested to FMVSS/CMVSS 108 requirements."



7.5" x 3.28" x .82"

Bargman/Wesbar Bulk	Bargman Clam Shell	Bargman Bagged	Wesbar Packaging	Description
50-767752				Red CHMSL w/Black Flange

Accessory Parts

85-767010				Chrome Trim Snap Ring
------------------	--	--	--	-----------------------

NOTE: Tail Lights, Clearance/Side Marker Lights and ID Light Bars approved for trailer accessory and towing application use. Contact your Cequent Performance Products Representative for details.





SUBMERSIBLE LED UNDER 80" COMBINATION TAIL LIGHTS 

These lights are ideal for boat and PWC trailers less than 80" wide and meet FMVSS/CMVSS 108 requirements. Stud mounted using 2" O.C. industry standard stud configuration. Prewired (supply and ground) for easy installation.

5.12" x 4.50" x 1.85" w/.86" depth



Bargman/Wesbar Bulk	Bargman Clam Shell	Bargman Bagged	Wesbar Packaging	Description
273006			283006	7-Function, Left/Roadside
273056			283056	6-Function, Right/Curbside

Complete kit with two tail lights, 25' trailer wiring harness cable with molded 4-way flat prong plug, 4' car harness cable with molded 4-way flat prong plug and license plate bracket.



Bargman/Wesbar Bulk	Bargman Clam Shell	Bargman Bagged	Wesbar Packaging	Description
			287512	Trailer Light Kit w/25' Wire Harness

SUBMERSIBLE LED OVER 80" COMBINATION TAIL LIGHTS 

These lights are ideal for boat and PWC trailers and meet FMVSS/CMVSS 108 requirements for trailers over 80" wide when properly mounted. Stud mounted using 2" O.C. industry standard stud configuration. Prewired (supply and ground) for easy installation.

5.48" x 4.50" x 1.85" w/.86" depth



Bargman/Wesbar Bulk	Bargman Clam Shell	Bargman Bagged	Wesbar Packaging	Description
273008				8 Function Left/Roadside
273058				7 Function Right/Curbside

NOTE: Tail Lights, Clearance/Side Marker Lights and ID Light Bars approved for trailer accessory and towing application use. Contact your Cequent Performance Products Representative for details.





SINGLE TAIL LIGHTS #86 SERIES

These lights meet FMVSS/CMVSS 108 requirements. Backup light has a clear lens surrounded by a Class "A" reflector. Bases are available in either white or black. All include J-slot bayonet sockets for dependable flicker-free operation and 16 gauge supply and ground wiring.

5 13/16" X 4 3/8" X 2 7/8", Cutout: 5 7/8" X 5 1/2"



Bargman/Wesbar Bulk	Bargman Clam Shell	Bargman Bagged	Wesbar Packaging	Description
30-86-001				Red Stop/Tail/Turn w/Colonial White Base
30-86-101	31-86-101	34-86-101		Red Stop/Tail/Turn w/Black Base
30-86-002				Turn Red w/Colonial White Base
30-86-102				Turn Red w/Black Base
30-86-004				Turn Amber w/ Colonial White Base
30-86-104	31-86-104	34-86-104		Turn Amber w/Black Base
30-86-103	31-86-103	34-86-103		Backup Vertical Mount w/Black Base
30-86-105				Backup Horizontal Mount w/Black Base

Replacement Parts

30-90-156				Bulb #1156, Single Filament
30-84-057				Bulb #2057, Double Filament
	31-84-010	34-84-010		Lens Red
	31-84-016	34-84-016		Lens Amber
	31-84-700	34-84-700		Lens Backup - Lens Mounted Vertical
	31-84-711	34-84-711		Lens Backup - Lens Mounted Horizontal
30-84-075				Tail Light Lens Screw

WRAP-AROUND CLEARANCE/SIDE MARKER LIGHTS #86 SERIES

This 90 degree wrap-around light meets lighting requirements for side markers and clearance lights and doubles as a Class "A" side-reflex reflector. The light meets FMVSS/CMVSS 108 requirements. Bases are available in either white or black. The molded socket with two wires protects bulb from road shock and the molded grommet protects the wiring.

5 3/4" X 4 3/8" X 2 3/16"



Bargman/Wesbar Bulk	Bargman Clam Shell	Bargman Bagged	Wesbar Packaging	Description
30-86-005				Red w/Colonial White Base
30-86-202		34-86-202		Red w/Black Base
30-86-006				Amber w/Colonial White Base
30-86-203		34-86-203		Amber w/Black Base

Replacement Parts

30-90-168		34-90-168		Bulb #168
30-86-711		34-86-711		Lens #86 Red Wrap Around
30-86-712		34-86-712		Lens #86 Amber Wrap Around
30-84-075				Marker Light Lens Screw

NOTE: Tail Lights, Clearance/Side Marker Lights and ID Light Bars approved for trailer accessory and towing application use. Contact your Cequent Performance Products Representative for details.



RECESSED DOUBLE TAIL LIGHTS #84 SERIES

These double lights are available for vertical or horizontal mounting. These styl- ish units with their radius corners come in black, white and colonial white. Clear backup light lenses are surrounded by a Class "A" red reflex lens. All lenses meet FMVSS/CMVSS 108 requirements. All include J-slot bayonet sockets for depend- able flicker-free operation and 16 gauge supply and ground wiring.

Cutout: 8 7/16" X 5 1/2", Overall: 9 13/16" X 6 15/16" X 1 1/4" w/ 1" depth

Bargman/ Wesbar Bulk	Bargman Clam Shell	Bargman Bagged	Wesbar Packaging	Description
30-84-001				Horizontal Mount w/Red Stop/Tail/Turn, Backup Lens w/Colonial White Base
30-84-540				Horizontal Mount w/Red Stop/Tail/Turn, Backup Lens w/White Base
30-84-008		34-84-008		Horizontal Mount w/Red Stop/Tail/Turn, Backup Lens w/Black Base
30-84-508				Vertical Mount w/Red Stop/Tail/Turn, Backup Lens w/Black Base
30-84-546				Red Stop/Tail/Turn & Amber Turn w/White Base
30-84-518				Red Stop/Tail/Turn & Amber Turn w/Black Base
30-84-547				Red/Red Stop/Tail/Turn w/White Base
30-84-527		34-84-527		Red/Red Stop/Tail/Turn w/Black Base
30-84-529		34-84-529		Red Stop/Tail/Turn, w/Red Insert (Clearance/Side Marker Application Only) w/Black Base

Replacement Parts

30-90-156				Bulb #1156, Single Filament
30-84-057				Bulb #2057, Double Filament
	31-84-010	34-84-010		Lens Red
	31-84-016	34-84-016		Lens Amber
	31-84-700	34-84-700		Lens Backup - Lens Mounted Vertical
	31-84-711	34-84-711		Lens Backup - Lens Mounted Horizontal
		34-85-750		Lens Red w/Red Insert (Clearance/Side Marker Application Only)
30-84-075				Tail Light Lens Screw

RECESSED TRIPLE LONG TAIL LIGHTS #84 SERIES

These triple tail lights incorporate all the features of the Recessed Triple Tail Light #84 Series with lens placement that allows a narrow mounting.

Cutout: 16 1/8" X 3 5/8", Overall: 18" X 5 5/16" X 1 1/4" w/ 1" depth"



Bargman/ Wesbar Bulk	Bargman Clam Shell	Bargman Bagged	Wesbar Packaging	Description
30-84-101				Horizontal Mount w/Red Stop/Tail/Turn, Center Backup, Red Stop/Tail/Turn w/Col. White Base
30-84-103				Horizontal Mount w/Red Stop/Tail/Turn, Center Backup, Red Stop/Tail/Turn w/Black Base
30-84-104				Horizontal Mount w/Red Stop/Tail/Turn, Center Backup, Amber Turn w/Black Base
30-84-554				Vertical Mount w/Red Stop/Tail/Turn, Center Backup, Amber Turn w/Black Base

Replacement Parts

30-90-156				Bulb #1156, Single Filament
30-84-057				Bulb #2057, Double Filament
	31-84-010	34-84-010		Lens Red
	31-84-016	34-84-016		Lens Amber
	31-84-700	34-84-700		Lens Backup - Lens Mounted Vertical
	31-84-711	34-84-711		Lens Backup - Lens Mounted Horizontal
		34-85-750		Lens Red w/Red Insert (Clearance/Side Marker Application Only)
30-84-075				Tail Light Lens Screw

NOTE: Tail Lights, Clearance/Side Marker Lights and ID Light Bars approved for trailer accessory and towing application use. Contact your Cequent Performance Products Representative for details.



RECESSED TRIPLE TAIL LIGHTS #84 SERIES/#85 SERIES

These triple lights are available for either vertical or horizontal mounting. These stylish units with their radius corners have bases available in either black, white, colonial white or chrome plated finish. Clear backup light lenses are surrounded by a Class "A" red reflex lens. All lenses meet FMVSS/CMVSS 108 requirements. All include J-slot bayonet sockets for dependable flicker-free operation and 16 gauge supply and ground wiring.

Cutout: 12 11/16" X 5 1/2", Overall: 14 1/16" X 6 15/16" X 1 1/4" w/ 1" depth

Bargman/ Wesbar Bulk	Bargman Clam Shell	Bargman Bagged	Wesbar Packaging	Description
30-84-002				Horizontal Mount w/Red, Red Stop/Tail/Turn, Backup w/Colonial White Base
30-84-530				Horizontal Mount w/Red, Red Stop/Tail/Turn, Backup w/White Base
30-84-009		34-84-009		Horizontal Mount w/Red, Red Stop/Tail/Turn, Backup w/Black Base
30-85-002				Horizontal Mount w/Red, Red Stop/Tail/Turn, Backup w/Chrome Base
30-84-003				Horizontal Mount w/Red Stop/Tail/Turn, Center Amber Turn, Backup w/Colonial White Base
30-84-005				Horizontal Mount w/Red Stop/Tail/Turn, Center Amber Turn, Backup w/Black Base
30-85-004				Horizontal Mount w/Red Stop/Tail/Turn, Center Amber Turn, Backup w/Chrome Base
30-84-522				Horizontal Mount w/Red Stop/Tail/Turn, Center Backup, Red Stop/Tail/Turn, w/Black Base
30-84-523				Vertical Mount w/Red/Red Stop/Tail/Turn, Backup w/White Base
30-84-509				Vertical Mount w/Red/Red Stop/Tail/Turn, Backup w/Black Base
30-85-003				Vertical Mount w/Red Stop/Tail/Turn, Center Amber Turn, Backup w/Chrome Base

Replacement Parts

30-90-156				Bulb #1156, Single Filament
30-84-057				Bulb #2057, Double Filament
	31-84-010	34-84-010		Lens Red
	31-84-016	34-84-016		Lens Amber
	31-84-700	34-84-700		Lens Backup - Lens Mounted Vertical
	31-84-711	34-84-711		Lens Backup - Lens Mounted Horizontal
		34-85-750		Lens Red w/Red Insert (Clearance/Side Marker Application Only)
30-84-075				Tail Light Lens Screw

NOTE: Tail Lights, Clearance/Side Marker Lights and ID Light Bars approved for trailer accessory and towing application use. Contact your Cequent Performance Products Representative for details.



SURFACE MOUNT TAIL LIGHTS #92 SERIES

Radius styling is the key to the smooth flowing design used in the #92 series tail light. Available with or without backup lenses, in red, these tail lights offer maximum design and replacement flexibility. Clean white or rich black bases. All include automotive corrosion resistant bulb sockets and 16 gauge supply and ground wiring. These lights meet FMVSS/CMVSS 108 requirements and are designed for long life and easy installation. These units are designed for horizontal, surface mounting only.

8 9/16" X 4 9/16" X 2 1/8"



Bargman/Wesbar Bulk	Bargman Clam Shell	Bargman Bagged	Wesbar Packaging	Description
30-92-001	31-92-001	34-92-001		Stop/Tail/Turn Light Surface Mount #92 w/White Base
30-92-106				Stop/Tail/Turn Light Surface Mount #92 w/Black Base
30-92-003	31-92-003	34-92-003		Stop/Tail/Turn Light Surface Mount #92 w/ License Light & Bracket w/White Base
30-92-108				Stop/Tail/Turn Light Surface Mount #92 w/ License Light & Bracket w/Black Base
30-92-002		34-92-002		Stop/Tail/Turn Light Surface Mount #92 w/ Backup w/White Base
30-92-107				Stop/Tail/Turn Light Surface Mount #92 w/ Backup w/Black Base
30-92-004		34-92-004		Stop/Tail/Turn Light Surface Mount #92 w/ Backup w/License Light & Bracket w/White Base
30-92-109				Stop/Tail/Turn Light Surface Mount #92 w/ Backup w/License Light & Bracket w/Black Base

Replacement Parts

30-90-156				Bulb #1156, Single Filament
30-90-157				Bulb #1157, Double Filament
30-92-012		34-92-012		Lens for 30-92-001, 106
30-92-704		34-92-704		Lens for 30-92-002, 107
30-92-708		34-92-708		Lens for 30-92-003, 108
30-92-713		34-92-713		Lens for 30-92-004, 109

WEDGE BASE FOR #92 SERIES TAIL LIGHTS

With the correct wedge, legal photometric function can be attained for the #92 Series tail lights which are mounted on surface angles as much as 15 degrees off the perpendicular.



Bargman/Wesbar Bulk	Bargman Clam Shell	Bargman Bagged	Wesbar Packaging	Description
30-92-044				Tail Light 15 Degree Wedge Base for #92 Series, White #7, 9" x 5 1/8" x 1 1/2"
30-92-064				Tail Light 15 Degree Wedge Base for #92 Series, Black, 9" x 5 1/8" x 1 1/2"

NOTE: Tail Lights, Clearance/Side Marker Lights and ID Light Bars approved for trailer accessory and towing application use. Contact your Cequent Performance Products Representative for details.



SURFACE MOUNT TAIL LIGHTS #07 SERIES

Combination stop, tail and turn lights feature radius styling, white base and snap-on lens. Unprecedented design flexibility for vertical or horizontal applications, 8 different mounting combinations possible. Prewired (supply and ground) for easy installation. Meet FMVSS/CMVSS 108 requirements (AIST 07 DOT). **NOTE: Units with license plate light and bracket approved for horizontal mounting only.**

8 7/16" x 5 15/16" x 2 5/16"



Bargman/Wesbar Bulk	Bargman Clam Shell	Bargman Bagged	Wesbar Packaging	Description
30-07-001				Stop/Tail/Turn Light Surface Mount #07 Series
30-07-002				Stop/Tail/Turn Light Surface/Horizontal Mount #07 Series w/License Light & Bracket
30-07-003				Stop/Tail/Turn Light Surface Mount #07 Series
30-07-100				Stop/Tail/Turn Light Surface/Horizontal Mount #07 Series w/License Light & Bracket

Replacement Parts

30-84-057				Bulb #2057, Double Filament
30-07-010				Lens for 30-07-001
30-07-011				Lens for 30-07-002
30-07-012				Lens for 30-07-003
30-07-013				Lens for 30-07-100

SURFACE MOUNT TAIL LIGHT #07 SERIES MOUNTING COMBINATIONS

Horizontal Mounting Combinations



Vertical Mounting Combinations

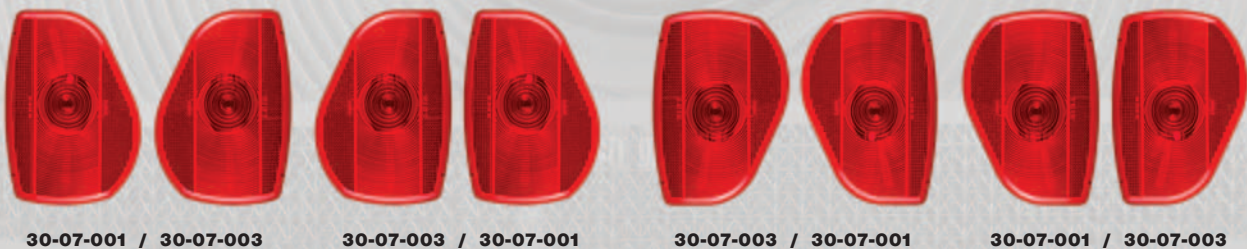



COMBINATION UNDER 80" TAIL LIGHTS #80 SERIES

Universal 2" on center stud mounting. Screw-on main and side marker lens allow for easy bulb replacement. This tail light is designed for a variety of under 80" light-duty trailers. Wiring uses the quick connect and disconnect feature. These tail lights meet FMVSS/CMVSS 108 requirements.

4 3/4" x 4 1/2" x 2 9/16"



Bargman/Wesbar Bulk	Bargman Clam Shell	Bargman Bagged	Wesbar Packaging	Description
2423283			2823283	7-Function, Left/Roadside
2423284			2823284	6-Function, Right/Curbside

Complete kit with two tail lights, two amber clearance/side marker lights with reflex lens, 20' or 25' trailer wiring harness cable with molded 4-way flat prong plug, 4' car wiring harness cable with molded 4-way flat prong plug plus license plate bracket.

Bargman/Wesbar Bulk	Bargman Clam Shell	Bargman Bagged	Wesbar Packaging	Description
	31-2823285		2823285	Trailer Light Kit w/25' Wire Harness, w/ Rectangular Clearance/Side Marker Lights
			407500	Trailer Light Kit w/20' Wire Harness, w/o Clearance/Side Marker Lights
109356				Trailer Light Kit w/15' Trailer Harness w/ Rectangular Ear-Mount Clearance/Side Marker Lights (Boxed)

Replacement Parts

108891				Bulb #193
30-90-157				Bulb #1157, Double Filament
2423286				Lens, Tail Light
2423287				Lens, Red, Clearance/Side Marker
003201			003211	License Plate Bracket
002301			707275	4' Wiring Harness w/4-Way Flat Car End
002220				20' Wiring Harness w/4-Way Flat Trailer End

COMBINATION OVER 80" TAIL LIGHTS #80 SERIES

Universal 2" on center stud mounting. Screw-on main and side marker lens allow for easy bulb replacement. These tail lights meet FMVSS/CMVSS 108 requirements for trailers over 80" wide when properly mounted. Wiring uses the quick connect and disconnect feature.

6.09" x 4.59" x 2.87"



Bargman/Wesbar Bulk	Bargman Clam Shell	Bargman Bagged	Wesbar Packaging	Description
2423293			2823293	8-Function, Left/Roadside
2423294			2823294	7-Function, Right/Curbside

Replacement Parts

108891				Bulb #193
30-90-157				Bulb #1157, Double Filament
2423286				Lens, Tail Light
2423297				Lens, Red, Clearance/Side Marker

NOTE: Tail Lights, Clearance/Side Marker Lights and ID Light Bars approved for trailer accessory and towing application use. Contact your Cequent Performance Products Representative for details.



TAIL LIGHTS #1500 SERIES

This popular stop-tail-turn light comes with a two stud mount. The light has a 4 1/4" acrylic snap-on lens, and is available with or without a license light. Has 16 gauge supply wiring and is self-grounding.

4 1/4" dia. x 3 1/8"



Bargman/Wesbar Bulk	Bargman Clam Shell	Bargman Bagged	Wesbar Packaging	Description
30-15-001		34-15-001		2-Stud Mount Red Stop/Tail/Turn
30-15-101		34-15-101		2-Stud Mount Red Stop/Tail/Turn w/License Light
30-15-151		34-15-151		2-Stud Mount Red Stop/Tail/Turn w/License Light & Bracket
30-15-103				2-Stud Mount Backup Light

Designed for permanent mounting. Kit comes complete with two #1500 series 2-stud mount tail lights, 25' trailer wiring harness cable with molded 4-way plug, 4' four wire car wiring harness cable with molded 4-way plug plus one black enamel license bracket.



Bargman/Wesbar Bulk	Bargman Clam Shell	Bargman Bagged	Wesbar Packaging	Description
	30-15-350			Trailer Light Kit (boxed)

Replacement Parts

30-90-157				Bulb #1157, Double Filament
30-16-155		34-16-155		License Plate Bracket
30-17-011		34-17-011		Lens #1500 Red
30-15-015				Lens #1500 Clear
002301			707275	4' Wiring Harness w/4-Way Flat Car End
108825			707261	25' Wiring Harness w/4-Way Flat Trailer End



MAGNETIC TOWLIGHT KIT

- 4-Flat hookup
- Mounts in any position vertically or horizontally
- Sealed, watertight housing
- 26' connector
- Plastic carrying case included



Tow Ready Bulk	Bargman Clam Shell	Bargman Bagged	Wesbar Packaging	Description
18148				Magnetic Towlight Kit (Plastic Carrying Case)

NOTE: Tail Lights, Clearance/Side Marker Lights and ID Light Bars approved for trailer accessory and towing application use. Contact your Cequent Performance Products Representative for details.



SURFACE MOUNT TAIL LIGHTS #15 SERIES

This compact light is perfect for use on smaller trailers, carts and shuttle units. Featuring the smooth look of pillow optics, the light comes with base mounting gasket, two wire construction and has double filament bulb to meet stop, tail and turn functions.

4 9/16" x 2 1/2" x 1 3/4"

Bargman/ Wesbar Bulk	Bargman Clam Shell	Bargman Bagged	Wesbar Packaging	Description
40-15-001		44-15-001		Red Stop/Tail/Turn Light
40-15-003				Amber Turn Light

Replacement Parts

30-84-057				Bulb #2057, Double Filament
-----------	--	--	--	-----------------------------



PEDESTAL MOUNT TAIL LIGHTS

This combination signal light requires a 1/2" hole for stud mounting. All mounting hardware included. For easy installation the lights feature prewired supply wires and are self-grounding. Red or amber snap-on acrylic lens and black acrylic cover. Meets FMVSS/CMVSS 108 requirements and meets ASABE 4 Candle Power to the side amber light requirements.

4.28" dia. x 2.16"

Bargman/ Wesbar Bulk	Bargman Clam Shell	Bargman Bagged	Wesbar Packaging	Description
2423273				Double Face: Amber Marker/Turn - Amber Marker/Turn
2423274				Double Face: Red Stop/Tail/Turn - Amber Marker/Turn
2423275				Single Face: Red Stop/Tail/Turn - Black

Replacement Parts

30-90-156				Bulb #1156, Single Filament
30-90-157				Bulb #1157, Double Filament



MOBILE HOUSING TAIL LIGHT

An economical tail and turn light with Class "A" reflex reflector for transporting mobile housing units that meets FMVSS/CMVSS 108 requirements. Manufactured with automotive style socket and 16 gauge supply wire. The 1" x 7" galvanized steel grounding/mounting plate has been permanently fastened to the housing for trouble-free use.

5 1/4" dia. x 3 1/8"

Bargman/ Wesbar Bulk	Bargman Clam Shell	Bargman Bagged	Wesbar Packaging	Description
30-11-001		34-11-001		Red Mobile Housing Tail Light

Replacement Parts

30-84-057				Bulb #2057, Double Filament
30-11-030				Lens Mobile Housing / #1600 Red

NOTE: Tail Lights, Clearance/Side Marker Lights and ID Light Bars approved for trailer accessory and towing application use. Contact your Cequent Performance Products Representative for details.



WATERPROOF/SEALED RECESSED TAIL LIGHTS

#01 SERIES 



Hermetically sealed lens prevents corrosion contributed by salt and rain. Structurally immune to extreme heat and cold. Lenses meet FMVSS/CMVSS 108 requirements. Rubber grommet and three wire pigtail can be purchased separately or as a kit.

4 1/4" dia. x 2 1/16" depth; Cutout: 1) 4 9/16" +/- 1/32" w/grommet when using steel 16 ga. or thicker, 2) 4 1/2" +/- 1/32" w/grommet when using fiberglass or 18 ga. or thinner steel.

Bargman/Wesbar Bulk	Bargman Clam Shell	Bargman Bagged	Wesbar Packaging	Description
		44-01-031		Red Stop/Tail/Turn Light w/Grommet w/Standard Pigtail

Replacement Parts

40-01-001		44-01-001		Red Stop/Tail/Turn Light
40-01-003				Clear Backup Light
40-00-003		44-00-003		3 Wire Pigtail w/12" Wire Lead
40-00-004			719063	3 Wire 90° Pigtail w/12" Wire Lead
40-01-020		44-01-020		4" Round Grommet

WATERPROOF/SEALED RECESSED TAIL LIGHTS

#06 SERIES 



Oval design allows for installation in narrower channels. Hermetically sealed lens prevents corrosion contributed by salt and rain. Structurally immune to extreme heat and cold. Lenses meet FMVSS/CMVSS 108 requirements. Rubber grommet and three wire pigtail can be purchased separately or as a kit. Mounting bracket of 11 ga. steel available separately.

6 1/2" x 2 1/4" x 2 3/8" depth, Cutout: 6 3/4" x 2 1/2"

Bargman/Wesbar Bulk	Bargman Clam Shell	Bargman Bagged	Wesbar Packaging	Description
413560		44-06-031	403080	Red Stop/Tail/Turn Light w/Grommet w/Standard Pigtail
		44-06-041		Red Stop/Tail/Turn Light w/Grommet w/90° Pigtail
		44-06-032		Amber Turn Light w/Grommet w/Standard Pigtail
		44-06-042		Amber Turn Light w/Grommet w/90° Pigtail
		44-06-033		Clear Backup Light w/Grommet w/Standard Pigtail
		44-06-043		Clear Backup Light w/Grommet w/90° Pigtail

Replacement Parts

40-06-001		44-06-001	403085	Red Stop/Tail/Turn Light
40-06-002		44-06-002		Amber Turn Light
40-06-003		44-06-003	403087	Clear Backup Light
40-00-003		44-00-003		3 Wire Pigtail w/12" Wire Lead
40-00-004			719063	3 Wire 90° Pigtail w/12" Wire Lead
40-06-020		44-06-020	416088	6" Oval Grommet
106205		34-108119	106873	6" Oval Mounting Bracket
			401591	6" Oval Grommet and 3 Wire 90° Pigtail

NOTE: Tail Lights, Clearance/Side Marker Lights and ID Light Bars approved for trailer accessory and towing application use. Contact your Cequent Performance Products Representative for details.





WATERPROOF OVER 80" 3X8 LOW PROFILE TAIL LIGHTS

Featuring a reliable waterproof design, these lights have a bulb replaceable capsule that protects the bulbs from corrosion and thermal shock but still allows for easy access for bulb replacement. These lights meet FMVSS/CMVSS 108 requirements for trailers over 80" wide when properly mounted.

8.03" x 2.94" x 2.83"

Bargman/Wesbar Bulk	Bargman Clam Shell	Bargman Bagged	Wesbar Packaging	Description
006554			403076	7-Function, Right/Curbside, Two Supply Wires and Ring Terminal Ground
006504			403026	8-Function, Left/Roadside, Two Supply Wires and Ring Terminal Ground
106411				7-Function, Right/Curbside, Trailer Ground Connection w/ Molded 2-Way Plug and Ring Terminal Ground
106410				8-Function, Left/Roadside, Trailer Ground Connection w/ Molded 2-Way Plug and Ring Terminal Ground

The kit comes complete with two tail lights, two sealed amber surface mount clearance/side marker lights with reflex lens, 25' trailer wiring harness cable with molded four prong plug, 4' four wire car wiring harness cable with molded 4-way plug plus license plate bracket.



Bargman/Wesbar Bulk	Bargman Clam Shell	Bargman Bagged	Wesbar Packaging	Description
007539			007509	Trailer Light Kit w/25' Wire Harness

Replacement Parts

108891				Bulb #193
30-84-057				Bulb #2057, Double Filament
102641				Lens Red, Tail Light
102639				Lens Red, Clearance/Side Marker
		90-03-336	403336	Lens Set Red, (2) Tail Light and (2) Clearance/Side Marker w/Screws
003101			203111	Clearance Light Amber w/Black Stud Mount Base
003201			003211	License Plate Bracket
002301			707275	4' Wiring Harness w/4-Way Flat Car End
108825			707261	25' Wiring Harness w/4-Way Flat Trailer End

BULB CAPSULE



Capsule protects bulbs from corrosion, thermoshock and environmental failure. Replacement for capsules used on a variety of Wesbar waterproof over 80" low profile and wrap-around tail lights. Available in permanently sealed version.

Bargman/Wesbar Bulk	Bargman Clam Shell	Bargman Bagged	Wesbar Packaging	Description
003308			403348	Bulb Capsule - Permanently Sealed

NOTE: Tail Lights, Clearance/Side Marker Lights and ID Light Bars approved for trailer accessory and towing application use. Contact your Cequent Performance Products Representative for details.

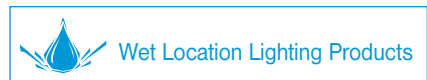



SUBMERSIBLE UNDER 80" TAIL LIGHTS 

These lights are ideal for boat and PWC trailers less than 80" wide. Fully gasketed, screw on main and side marker lens allow for easy bulb replacement. Universal 2" on-center stud mount.

5.25" x 4.66" x 3.76" overall height



Bargman/Wesbar Bulk	Bargman Clam Shell	Bargman Bagged	Wesbar Packaging	Description
2423056			2523073	6-Function, Right/Curbside
2423006			2523023	7-Function, Left/Roadside

This kit comes complete with two pre-wired tail lights, 25' trailer wiring harness cable with molded four prong plug, 4' four wire car wiring harness cable with molded 4-way plug plus license plate bracket.



Bargman/Wesbar Bulk	Bargman Clam Shell	Bargman Bagged	Wesbar Packaging	Description
			2527511	Trailer Light Kit w/25' Wire Harness

Replacement Parts

108891				Bulb #193
30-90-157				Bulb #1157, Double Filament
2423286				Lens Red, Tail Light
54001				Lens Red, Tail Light w/Screws (Bagged)
2423287				Lens Red, Clearance/Side Marker
54002				Lens Red, Clearance/Side Marker w/Screws (Bagged)

NOTE: Tail Lights, Clearance/Side Marker Lights and ID Light Bars approved for trailer accessory and towing application use. Contact your Cequent Performance Products Representative for details.





SUBMERSIBLE OVER 80" 4X6 LOW PROFILE TAIL LIGHTS



Unique, compact size and shape allows these lights to fit where space is limited. The lens is sonically-sealed to the base providing a "bell jar," making this lamp fully submersible with easily replaceable bulbs. These lights meet FMVSS/CMVSS 108 requirements for trailers over 80" wide when properly mounted. Pre-wired with 2-way molded plugs and ring terminal ground for easy installation.

6" x 3 1/2" x 2 1/4"

Bargman/Wesbar Bulk	Bargman Clam Shell	Bargman Bagged	Wesbar Packaging	Description
423075			403075	7-Function, Right/Curbside
423025			403025	8-Function, Left/Roadside

The kit comes complete with two tail lights, two amber clearance/side marker lights with reflex lens, 20' trailer wiring harness cable with molded four prong plug, 4' four wire car wiring harness cable with molded 4-way plug plus license plate bracket.



Bargman/Wesbar Bulk	Bargman Clam Shell	Bargman Bagged	Wesbar Packaging	Description
417515			407515	Trailer Light Kit w/20' Wire Harness

Replacement Parts

108891				Bulb #193
30-90-157				Bulb #1157, Double Filament
223117			203117	Clearance/Side Marker, Amber, Stud Mount w/ Reflex
003328				Lens Amber, Clearance/Side Marker
		90-03-328	003338	Lens Amber, Clearance/Side Marker w/Screw
003201			003211	License Plate Bracket
002301			707275	4' Wiring Harness w/4-Way Flat Car End
002220				20' Wiring Harness w/4-Way Flat Trailer End

SUBMERSIBLE OVER 80" TAIL LIGHTS



These lights are ideal for boat and PWC trailers over 80" wide. Fully gasketed, screw on main and side marker lenses allow for easy bulb replacement. Universal 2" on-center stud mount. These lights meet FMVSS/CMVSS 108 requirements for trailers over 80" wide when properly mounted. Prewired for easy installation.

6.29" x 4.66" x 3.76" overall height

Bargman/Wesbar Bulk	Bargman Clam Shell	Bargman Bagged	Wesbar Packaging	Description
2423058			2523074	7-Function, Right/Curbside
2423008			2523024	8-Function, Left/Roadside

Replacement Parts

108891				Bulb #193
30-90-157				Bulb #1157, Double Filament
2423286				Lens Red, Tail Light
54001				Lens Red, Tail Light w/Screws (Bagged)
2423297				Lens Red, Clearance/Side Marker
54003				Lens Red, Clearance/Side Marker w/Screws (Bagged)

NOTE: Tail Lights, Clearance/Side Marker Lights and ID Light Bars approved for trailer accessory and towing application use. Contact your Cequent Performance Products Representative for details.

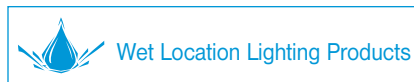



TRACTOR LIGHT WITH RUBBER HOUSING

12v flood light with shockproof rubber housing. Single wire, self-grounding with single stud mounting. #4406 Par 36 sealed beam.

Bargman/Wesbar Bulk	Bargman Clam Shell	Bargman Bagged	Wesbar Packaging	Description
30-073840		34-073840		Auxiliary Light



LED WORK LIGHTS

LED work lights perfect for exterior use in AG, horse, livestock, RV, industrial and racing applications. Environmentally sealed design with aluminum housing and stainless steel mounting stud. High power, true white 9-36V, 10W light emission. Rectangular version with 10 LED diodes, circular model has 6 LED diodes.

Circular: 4.5" dia. x 1.5" depth
 Rectangular: 4" x 4" x 1.5" depth

Bargman/Wesbar Bulk	Bargman Clam Shell	Bargman Bagged	Wesbar Packaging	Description
54209-001				Circular LED Light, 6 Diodes
54209-002				Rectangular LED Light, 10 Diodes



LED WORK LIGHTS WITH COILED CORD & MAGNETIC BASE

LED work lights perfect for exterior use in AG, horse, livestock, RV, industrial and racing applications. Environmentally sealed design with 19' extended coiled cord. Magnetic base, with protective film, secures in high vibration conditions in a vertical or horizontal position. Power adapter for 12V outlet with separate on/off switch. High power, true white 9-36V, 10W light emission. Rectangular version with 10 LED diodes, circular model has 6 LED diodes.

Circular: 4.5" dia. x 1.875" depth
 Rectangular: 4" x 4" x 1.75" depth

Bargman/Wesbar Bulk	Bargman Clam Shell	Bargman Bagged	Wesbar Packaging	Description
54209-017				Circular LED Light, w/Cord, Magnetic Base, 6 Diodes
54209-018				Rectangular LED Light, w/Cord, Magnetic Base, 10 Diodes

NOTE: Tail Lights, Clearance/Side Marker Lights and ID Light Bars approved for trailer accessory and towing application use. Contact your Cequent Performance Products Representative for details.



WATERPROOF LAUNCH LIGHTS 

Designed to illuminate the back or side of trailers, these lights help to launch and load under low light conditions (requires five-wire trailer harness). Lights are powerful, yet small enough to fit in tight areas and can be either grommet or snap-lock base-mounted. Lens and base are constructed of extra-tough polycarbonate to resist damage.

Bargman/ Wesbar Bulk	Bargman Clam Shell	Bargman Bagged	Wesbar Packaging	Description
203206				Module, Courtesy / Launch Light

Replacement Parts

40-37-020		44-37-020		Black 2" Snap-Lock Base, Self Grounding w/ Single Black Wire
106289				Black 2" Snap-Lock Base, Self Grounding
108297				Black 2" Snap-Lock Base, Open Back
106293		34-106293		Chrome 2" Snap-Lock Base, Self-Grounding
106294		34-106294		Chrome 2" Snap-Lock Base, Open Back
221588				Grommet, Rectangular
40-00-002		44-00-002		2 Wire Pigtail w/6" Wire Lead
108663		34-108663		2 Wire Pigtail w/18" Wire Lead



WATERPROOF COURTESY LIGHTS 

Sealed lights with #193 bulbs are ideal for a variety of interior and exterior applications. Lens and base are constructed of extra-tough polycarbonate to resist damage.

2.15" x 1.125" x 1.035" w/.7" depth

Bargman/ Wesbar Bulk	Bargman Clam Shell	Bargman Bagged	Wesbar Packaging	Description
003232				Courtesy Light w/Self-Grounding Stud Mount, Single Wire w/Molded Barrel

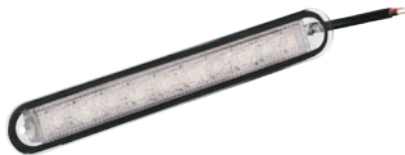

WATERPROOF LED COURTESY LIGHT 

Sealed courtesy light features LED technology with 10 diodes. Prewired (supply and ground) for easy installation. Features rubber mounting gasket and includes mounting screws and screw plugs. **Non-DOT applications only.**

2.15" x 1.125" x 1.035" w/ .7" depth

Bargman/ Wesbar Bulk	Bargman Clam Shell	Bargman Bagged	Wesbar Packaging	Description
47-05-151				LED Courtesy Light Clear



WATERPROOF LED 6" OVAL GROMMET MOUNT COURTESY LIGHT 

Waterproof 10 diode courtesy/utility light. Horizontal and vertical mount applications. LED provides longer life, brighter more focused illumination and less current draw than incandescent lamps. Grommet and 3 prong wiring pigtail available separately.

6.42" x 2.25" x 1.00 w/.77" depth

Bargman/ Wesbar Bulk	Bargman Clam Shell	Bargman Bagged	Wesbar Packaging	Description
			54005	LED Oval Courtesy Light Clear w/Grommet w/3 Wire 90° Pigtail
273560				LED Oval Courtesy Light Clear

Accessory Parts

40-00-003		44-00-003		3 Wire Pigtail w/12" Wire Lead
40-00-004			719063	3 Wire 90° Pigtail w/12" Wire Lead
40-06-020		44-06-020	416088	6" Oval Grommet
106205		34-108119	106873	6" Oval Mounting Bracket
			401591	6" Oval Grommet & 3 Wire 90° Pigtail





LED HEAVY-DUTY AG LIGHTS

Available in single and dual units, these lights meet all ASABE S279.15 lighting requirements including 4cp to side on amber lens. Dual lights designed for right hand and left hand vertical mounting. Rugged external housing and lens design. Same mounting foot print hardware and electrical connections as incandescent equivalent. Brake functions wired with SQ-4 plug.

6" x 5 1/2" x 3", 10 1/2" x 5 1/2" x 3"

Bargman/Wesbar Bulk	Bargman Clam Shell	Bargman Bagged	Wesbar Packaging	Description
54209-010				Single LED AG Light w/Red/Black
54209-012				Single LED AG Light w/Amber/Amber
54209-006				Dual LED AG Light w/Amber/Red
54209-020				Dual LED AG Light w/Red/Amber
54209-008				Dual LED AG Light w/Amber/Red w/Brake Light Function
54209-022				Dual LED AG Light w/Red/Amber w/Brake Light Function

Note: Reference AG Lighting - Technical for mounting applications.

Note: Custom AG lighting and wiring kits are available. Contact your Cequent representative for requirements and minimum annual quantities.

LED ECONOMY AG LIGHT KIT

Featuring left hand and right hand dual light units, this kit include a 35 ft. wishbone wire harness, 7-pin AG plug and tri-plugs. For protection in critical areas, 5' of convoluted tubing is included.

New

Bargman/Wesbar Bulk	Bargman Clam Shell	Bargman Bagged	Wesbar Packaging	Description
54003-040				Economy AG LED Light Kit

Replacement Parts

54209-006				Dual AG LED Light w/Amber/Red
54209-020				Dual AG LED Light w/Red/Amber

US Patent D347,903/5,335, 155

NOTE: Reference AG Lighting - Technical for mounting applications.

LED AG TRANSPORT LIGHT KITS

Featuring left and right hand dual light units with brake function, these kits include a 46 ft. round wishbone cable, 4 – 90 lb. magnets and a 7-pin round plug.

New

Bargman/Wesbar Bulk	Bargman Clam Shell	Bargman Bagged	Wesbar Packaging	Description
54003-041				Deluxe AG LED Transport Kit w/Brake Light Function, 7-Pin

Replacement Parts

54209-008				Dual LED AG Light w/Amber/Red w/Brake Light Function
54209-022				Dual LED AG Light w/Red/Amber w/Brake Light Function
002590				Magnet Kit, 90 lb. Pull

US Patent D347,903/5,335, 155

NOTE: Reference AG Lighting - Technical for mounting applications.



HEAVY-DUTY AG LIGHTS

Available in single and dual units, these lights meet all ASABE S279.13 lighting requirements including 4cp to side on amber lens. Dual lights designed for right hand-horizontal/vertical mounting or left hand-horizontal/vertical mounting. Rugged external housing and lens design with vibration dampening bulb holder. Brake functions wired with SQ-4 plug.

6" x 5 1/2" x 3", 10 1/2" x 5 1/2" x 3"

Bargman/Wesbar Bulk	Bargman Clam Shell	Bargman Bagged	Wesbar Packaging	Description
8260501				Single AG Light w/Red/Black
8260601				Single AG Light w/Amber/Amber
8261001				Single AG Light w/Red/Black w/Brake Light Function
8260001				Dual AG Light w/Amber/Red
8260101				Dual AG Light w/Red/Amber
8261501				Dual AG Light w/Amber/Red w/Brake Light Function
8261601				Dual AG Light w/Red/Amber w/Brake Light Function

Replacement Parts

30-90-157				Bulb #1157, Double Filament
802650				Lens Amber, AG Lamp
802651				Lens Red, AG Lamp
802652				Insert Black, AG Lamp

Note: Reference AG Lighting - Technical for mounting applications.



ECONOMY AG LIGHT KIT

Featuring left hand and right hand dual light units, this kit include a 35 ft. wishbone wire harness, 7-pin AG plug and tri-plugs. For protection in critical areas, 5' of convoluted tubing is included.

Bargman/Wesbar Bulk	Bargman Clam Shell	Bargman Bagged	Wesbar Packaging	Description
002670				Economy AG Light Kit

Replacement Parts

8260001				Dual AG Light w/Amber/Red
8260101				Dual AG Light w/Red/Amber

US Patent D347,903/5,335,155

NOTE: Reference AG Lighting - Technical for mounting applications.



AG TRANSPORT LIGHT KITS

Featuring left and right hand dual light units with brake function, these kits include a 46 ft. round wishbone cable, 4 – 90 lb. magnets and either a 7-pin or 6-pin round plug.

Bargman/Wesbar Bulk	Bargman Clam Shell	Bargman Bagged	Wesbar Packaging	Description
002675				Deluxe AG Transport Kit w/Brake Light Function, 6-Pin
002676				Deluxe AG Transport Kit w/Brake Light Function, 7-Pin

Replacement Parts

8261501				Dual AG Light w/Amber/Red w/Brake Light Function
8261601				Dual AG Light w/Red/Amber w/Brake Light Function
002590				Magnet Kit, 90 lb. Pull

US Patent D347,903/5,335,155

Note: Reference AG Lighting - Technical for mounting applications.

NOTE: Tail Lights, Clearance/Side Marker Lights and ID Light Bars approved for trailer accessory and towing application use. Contact your Cequent Performance Products Representative for details.



7-WAY ROUND PIN AG CONNECTORS

A discrete round pin 7-way vehicle and implement connector for AG OEM and aftermarket use. Vehicle side connector includes a mountable storage box. Implement side connector includes a metal spring cable relief



Part No.	Description	Packaging
787305	7-Way Round Pin AG Vehicle Connector	Bulk
787303	7-Way Round Pin AG Vehicle Connector	Clam - Wesbar
787304	7-Way Round Pin AG Trailer Connector	Bulk
787302	7-Way Round Pin AG Trailer Connector	Clam - Wesbar

7-WAY MOLDED TRAILER CONNECTORS WITH CABLE - TRAILER CLOCKING



7-way plastic connector molded to heavy duty 7-way insulated cable using trailer clocking*. Provides 7-way connector contact color coding more conducive to horse and livestock trailers verses RV trailers. Made with self-cleaning contacts and molded to encapsulate terminals and wires to form one weather resistant, non-corrosive assembly. Permits the trailer to have the clean appearance and environmental advantages of a sealed, molded 7-way cord. Primary wire gauges within the insulated cable are: Black and White-10 gauge, Blue-12 gauge, Brown-Red-Green-Yellow-14 gauge.



Note: Various length and combinations available. Crimped junction box terminals can be added. Contact your Cequent Performance Products Representative for details.

Part No.	Description	Packaging
50-67-614	7-Way Molded Trailer Cord w/4' Cable	Bulk
50-67-616	7-Way Molded Trailer Cord w/6' Cable	Bulk
50-67-618	7-Way Molded Trailer Cord w/8' Cable	Bulk
50-67-620	7-Way Molded Trailer Cord w/10' Cable	Bulk

*NOTE: Reference Wiring Diagrams for pin locations.

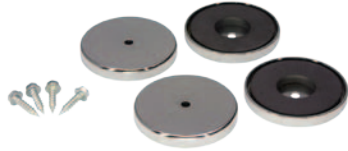

MAGNET KIT

Use of this magnet kit allows for temporary installation of single or dual lights. Set of four with hardware.

Bargman/Wesbar Bulk	Bargman Clam Shell	Bargman Bagged	Wesbar Packaging	Description
002590				Magnet Kit, 90 lb. Pull



TANDEM HAUL ADAPTER

The Tandem Haul Adapter allows implements to be towed in tandem, providing versatility and economy.

Bargman/Wesbar Bulk	Bargman Clam Shell	Bargman Bagged	Wesbar Packaging	Description
002500				Tandem Haul Adapter
002625				Tandem Haul Kit



AG LIGHT ENHANCED LIGHTING MODULES

Install to meet the enhanced lighting standard and have a dramatic safety feature to better signal turns by tractors and implements. Contact your Cequent Representative for additional information.

Bargman/Wesbar Bulk	Bargman Clam Shell	Bargman Bagged	Wesbar Packaging	Description
108060				Module w/Wire Leads
108318				Module w/Molded Plugs
108319				Module w/Weatherproof Plugs
109992				Module w/Brake Light Signal Function w/Wire Leads

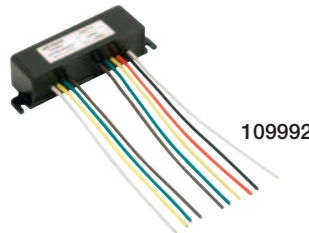

AG EXTENSION HARNESSES

Install on towable field implements to bring power from the tractor to AG Lights. Full length ground assures reliable and continuous operation. **Custom configurations and lengths available.**

Bargman/Wesbar Bulk	Bargman Clam Shell	Bargman Bagged	Wesbar Packaging	Description
002510				10' Heavy-Duty Wishbone Harness
002408				5' Economy Extension Harness
002410				10' Economy Extension Harness
002415				15' Straight Section Harness w/7-Pin AG Plug and Flat 4-Way
002425				25' Straight Section Harness w/7-Pin AG Plug and Flat 4-Way
002430				30' Straight Section Harness w/7-Pin AG Plug and Flat 4-Way
002504				10' Economy Rear Wishbone Harness
002505				15' Economy Rear Wishbone Harness
002515				15' Heavy-Duty Rear Wishbone Harness





**WATERPROOF LED 2" ROUND CLEARANCE/
SIDE MARKER LIGHTS #30 SERIES** 

Waterproof LED clearance/side marker light with grommet designed for quick and easy installation. Flush mount rubber grommet and two wire pigtail.

Module only: 2" dia. x .97" height



Bargman/ Wesbar Bulk	Bargman Clam Shell	Bargman Bagged	Wesbar Packaging	Description
		47-30-031		Clearance Light LED #30 Red w/Grommet w/6" Pigtail
		47-30-032		Clearance Light LED #30 Amber w/Grommet w/6" Pigtail

Replacement Parts

47-30-001	42-30-401	47-30-401	401577	Clearance Light Module LED #30 Red
47-30-002	42-30-402	47-30-402	401576	Clearance Light Module LED #30 Amber
40-00-002		44-00-002		2 Wire Pigtail w/6" Wire Lead
108663		34-108663		2 Wire Pigtail w/18" Wire Lead
40-30-020		44-30-020		2" Round Grommet
			401589	2" Round Grommet and 2 Wire Pigtail w/6" Wire Lead

**WATERPROOF LED 2 1/2" ROUND CLEARANCE/SIDE MARKER
LIGHTS #31 SERIES WITH/ WITHOUT REFLEX LENS** 

Waterproof LED clearance/side marker light with grommet designed for quick and easy installation. Flush mount rubber grommet and two wire pigtail. Available with and without reflex lens.

Module only: 2.5" x .98" height



Bargman/ Wesbar Bulk	Bargman Clam Shell	Bargman Bagged	Wesbar Packaging	Description
		47-31-031		Clearance Light LED #31 Red w/Grommet w/6" Pigtail
		47-31-032		Clearance Light LED #31 Amber w/Grommet w/6" Pigtail
		47-31-033		Clearance Light LED #31 Red w/Reflex Lens w/ Grommet w/6" Pigtail

Replacement Parts

47-31-001		47-31-401	401579	Clearance Light Module LED #31 Red
47-31-003	42-31-403	47-31-403		Clearance Light Module LED #31 Red w/Reflex
47-31-002		47-31-402	401578	Clearance Light Module LED #31 Amber
47-31-004	42-31-404	47-31-404		Clearance Light Module LED #31 Amber w/ Reflex
40-00-002		44-00-002		2 Wire Pigtail w/6" Wire Lead
108663		34-108663		2 Wire Pigtail w/18" Wire Lead
40-31-020		44-31-020		2 1/2" Round Grommet
221088				2 1/2" Round Open Back Heavy Duty Grommet



NOTE: Tail Lights, Clearance/Side Marker Lights and ID Light Bars approved for trailer accessory and towing application use. Contact your Cequent Performance Products Representative for details.





WATERPROOF LED CLEARANCE/SIDE MARKER LIGHTS #37 SERIES

Waterproof LED clearance/side marker light designed for easy installation. Snap lock base mount. Tested and certified to FMVSS/CMVSS 108 side marker/clearance light requirements. P2 rated.

Module Only: 2.60" x 1.20" x 1.03" overall height

Module w/Base: 2-7/8" x 1-1/2" x 1"



Bargman/Wesbar Bulk	Bargman Clam Shell	Bargman Bagged	Wesbar Packaging	Description
		47-37-031		Clearance Light LED #37 Red w/Black Base w/6" Pigtail
		47-37-032		Clearance Light LED #37 Amber w/Black Base w/6" Pigtail
47-37-005				Clearance Light Module LED #37 Red, PC Rated When Properly Mounted
47-37-006				Clearance Light Module LED #37 Amber, PC Rated When Properly Mounted

Accessory/Replacement Parts

47-37-001	42-37-401	47-37-401	401581	Clearance Light Module LED #37 Red
47-37-002	42-37-402	47-37-402	401580	Clearance Light Module LED #37 Amber
40-37-020		44-37-020		Black 2" Snap-Lock Base, Self-Grounding w/ Single Black Wire
106289				Black 2" Snap-Lock Base, Self-Grounding
108297				Black 2" Snap-Lock Base, Open Back
106293		34-106293		Chrome 2" Snap-Lock Base, Self-Grounding
106294		34-106294		Chrome 2" Snap-Lock Base, Open Back
221588				Grommet Rectangular
40-00-002		44-00-002		2 Wire Pigtail w/6" Wire Lead
108663		34-108663		2 Wire Pigtail w/18" Wire Lead

WATERPROOF LED CLEARANCE/SIDE MARKER LIGHTS #99 SERIES

Waterproof mini LED clearance/side marker light with single wire, 12" minimum. Self-grounding stud mounting with 1/4" required hole. Includes type 302 stainless steel hardware. Meets FMVSS/CMVSS 108 requirements. PC rated when properly mounted.

2.16" x 1.16" x 1.03" w/.72" depth



Bargman/Wesbar Bulk	Bargman Clam Shell	Bargman Bagged	Wesbar Packaging	Description
47-99-005			401566	Clearance Light LED #99 Red
47-99-006			401565	Clearance Light LED #99 Amber

NOTE: Tail Lights, Clearance/Side Marker Lights and ID Light Bars approved for trailer accessory and towing application use. Contact your Cequent Performance Products Representative for details.

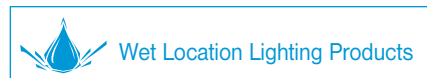



WATERPROOF LED CLEARANCE/SIDE MARKER LIGHT WITH REFLEX LENS 



Waterproof LED clearance/side marker "tongue" lights. Excellent for boat trailer tongue lighting. Snap-on lens with black or white bases. Two wire construction with either notched wires or molded single bullet and barrel. Tested to FMVSS/CMVSS 108 requirements. P2 rated.

2.62" x 1.83" x .83"

Bargman/Wesbar Bulk	Bargman Clam Shell	Bargman Bagged	Wesbar Packaging	Description
47-222012				Clearance Light LED Amber w/Reflex w/Black Base - BULLET SUPPLY, BARREL GROUND
47-222014				Clearance Light 1 Diode LED Red w/Reflex w/White Base - NOTCHED SUPPLY & GROUND WIRES
47-222015				Clearance Light 1 Diode LED Amber w/Reflex w/White Base - NOTCHED SUPPLY & GROUND WIRES

WATERPROOF LED CLEARANCE/SIDE MARKER LIGHTS 

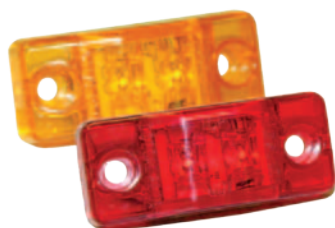

FMVSS/CMVSS 108 compliant waterproof LED clearance/side marker lights with 2 diodes. One piece design with thru-lens mounting holes. 18" two wire construction. P2/P3 rated.

2.6" x 1.1" x .75" height (mounting: (2) .25" dia. hole - 1.9" centers)



Bargman/Wesbar Bulk	Bargman Clam Shell	Bargman Bagged	Wesbar Packaging	Description
47-106853				Clearance Light LED Amber
			54201-001	Clearance Light LED Amber w/Chrome Bezel
47-106854				Clearance Light LED Clear Lens w/Amber Diodes
47-107047				Clearance Light LED Red
			54201-002	Clearance Light LED Red w/Chrome Bezel
47-107048				Clearance Light LED Clear Lens w/Red Diodes

Accessory Parts

47-106020				Chrome Bezel (3.23" x 1.73" x .47" height)
-----------	--	--	--	--

NOTE: Tail Lights, Clearance/Side Marker Lights and ID Light Bars approved for trailer accessory and towing application use. Contact your Cequent Performance Products Representative for details.





WATERPROOF LED CLEARANCE/SIDE MARKER LIGHTS 

Waterproof LED clearance/side marker lights. One piece design with thru-lens mounting holes. Self-grounding with a single stud mounting, 1/4" hole required. Features wire harness with either one or two wire configurations that includes notched wires or molded single bullets and/or barrels. P2/P3 rated.

2.64" x 1.14" x .97" w/.43" depth (mounting: (2) .25 dia. hole - 1.9" centers)

Bargman/Wesbar Bulk	Bargman Clam Shell	Bargman Bagged	Wesbar Packaging	Description
47-106851	42-99-402			Clearance Light LED Amber w/Stud Mounting, 12" Brown Wire
47-107043	42-99-401			Clearance Light LED Red w/Stud Mounting, 12" Brown Wire
47-106856			42-106856	Clearance Light LED Amber w/Stud Mounting, 12" Brown/White Wires
47-107045			42-107045	Clearance Light LED Red w/Stud Mounting, 12" Brown/White Wires
47-106852				Clearance Light LED Amber w/Stud Mounting, 162" Brown Bullet Pigtail
47-106857				Clearance Light LED Amber w/Stud Mounting, 162" Brown Bullet/White Barrel Pigtail
47-107044				Clearance Light LED Red w/Stud Mounting, 96" Brown Bullet/Brown Barrel Pigtail
47-107046				Clearance Light LED Red w/Stud Mounting, 96" Brown Bullet & Barrel/White Bullet & Barrel Pigtail



WATERPROOF LED CLEARANCE/SIDE MARKER LIGHTS 

One piece waterproof LED clearance/side marker lights designed for grommet mounting. Two wire pigtail features 6" or 18" wire leads with supply wire and ring terminal ground. Pigtail and grommet available separately. P2 rated.

2.61" x 1.22" x .79"

Bargman/Wesbar Bulk	Bargman Clam Shell	Bargman Bagged	Wesbar Packaging	Description
47-203667				Clearance Light Module LED Amber
47-203668				Clearance Light Module LED Red

Accessory Parts

221588				Grommet, Rectangular
40-00-002		44-00-002		2 Wire Pigtail w/6" Wire Lead
108663		34-108663		2 Wire Pigtail w/18" Wire Lead

NOTE: Tail Lights, Clearance/Side Marker Lights and ID Light Bars approved for trailer accessory and towing application use. Contact your Cequent Performance Products Representative for details.

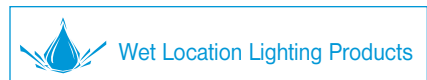



LED CLEARANCE/SIDE MARKER LIGHTS #59 SERIES WITH REFLEX LENS

Rugged ABS base with LED light engine assembled directly into reflectorized acrylic lens. LED light engine consists of 2 LED lights that are mounted into a circuit board that is then potted and sealed to protect against water and other elements.
4" x 2" x 1 1/32" w/5/8" depth



Bargman/Wesbar Bulk	Bargman Clam Shell	Bargman Bagged	Wesbar Packaging	Description
47-59-001	42-59-401	47-59-401		Clearance Light LED #59 Red w/White Base w/Pigtail
47-59-002	42-59-402	47-59-402		Clearance Light LED #59 Amber w/White Base w/Pigtail

Replacement Parts

30-58-102				Wedge Base Socket w/o Bulb
47-59-010	42-59-410	47-59-410		Lens Module LED #59 Red
47-59-012	42-59-412	47-59-412		Lens Module LED #59 Amber

LED UPGRADE KITS CLEARANCE/SIDE MARKER LIGHTS #59 SERIES WITH REFLEX LENS

#59 Series LED Upgrade Kits are designed to convert Bargman #59 Incandescent Clearance/Side Marker Lights to LED WITHOUT having to remove the base. Simply remove the lens and the incandescent bulb and plug in the LED light engine (lens and LED lights).



Bargman/Wesbar Bulk	Bargman Clam Shell	Bargman Bagged	Wesbar Packaging	Description
47-59-010	42-59-410	47-59-410		Upgrade Kit LED #59 Red
47-59-012	42-59-412	47-59-412		Upgrade Kit LED #59 Amber

LED CLEARANCE/SIDE MARKER LIGHT KITS #58 SERIES

LED oblong clearance/side marker light with snap lock base mount.
4" x 2" x 1"



Bargman/Wesbar Bulk	Bargman Clam Shell	Bargman Bagged	Wesbar Packaging	Description
		47-58-031		Clearance Light LED #58 Red w/Pigtail
		47-58-032		Clearance Light LED #58 Amber w/Pigtail
47-58-001			401586	Clearance Light LED #58 Red
47-58-002			401585	Clearance Light LED #58 Amber

Replacement Parts

40-00-005				Pigtail
-----------	--	--	--	---------

NOTE: Tail Lights, Clearance/Side Marker Lights and ID Light Bars approved for trailer accessory and towing application use. Contact your Cequent Performance Products Representative for details.



LED CLEARANCE/SIDE MARKER LIGHTS #38 SERIES

LED clearance/side marker light designed for easy installation. Snap lock base mount. Fully tested and certified to FMVSS/CMVSS 108 side marker/clearance light requirements. P2 rated.

Module Only: 3.93" x 1.22" x 1.02" overall height

Fender Mount Module Only: 3.95" x 1.24" x 1.038" overall height

Bargman/Wesbar Bulk	Bargman Clam Shell	Bargman Bagged	Wesbar Packaging	Description
	42-38-033	47-38-033	401583	Clearance Light LED #38 Red w/Black Base w/Pigtail
		47-38-035		Clearance Light LED #38 Red w/Chrome Base w/Pigtail
	42-38-034	47-38-034	401582	Clearance Light LED #38 Amber w/Black Base w/Pigtail
		47-38-036		Clearance Light LED #38 Amber w/Chrome Base w/Pigtail
47-38-005				Clearance Light Module LED #38 Red, PC Rated When Properly Mounted
47-38-006				Clearance Light Module LED #38 Amber, PC Rated When Properly Mounted
47-38-004				Fender Mount Clearance Light Module LED #38 Red/Amber
	42-38-035			Fender Mount Clearance Light Module LED #38 Red/Amber w/Black Base, Self-Grounding w/Single Black Wire

Replacement Parts

47-38-001		47-38-401		Clearance Light Module LED #38 Red
47-38-002		47-38-402		Clearance Light Module LED #38 Amber
40-38-020				Black Base w/Wire Assembly, Self-Grounding w/Single Black Wire
40-38-025				Black Base w/2 Wires

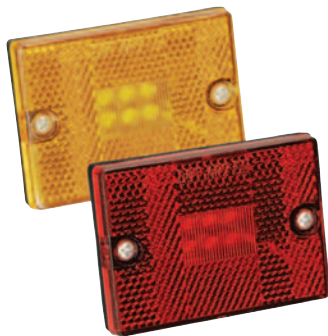

LED CLEARANCE/SIDE MARKER LIGHTS #42 SERIES WITH REFLEX LENS

Rectangular stud mount LED clearance/side marker light. Two wire construction and requires 1/4" hole for mounting.

2.84" x 2 1/8" x 7/8"

Bargman/Wesbar Bulk	Bargman Clam Shell	Bargman Bagged	Wesbar Packaging	Description
47-42-001	42-42-401	47-42-401		Clearance Light LED #42 Red w/Reflex
47-42-002	42-42-402	47-42-402		Clearance Light LED #42 Amber w/Reflex

NOTE: Tail Lights, Clearance/Side Marker Lights and ID Light Bars approved for trailer accessory and towing application use. Contact your Cequent Performance Products Representative for details.



WATERPROOF/SEALED CLEARANCE/ SIDE MARKER LIGHTS #37 SERIES 

Compact rectangular light with the polycarbonate lens sonic welded to the base. Offers easy installation with self grounding base on metallic surfaces. Snaplock tabs on the lens housing secures light to base to complete the fast installation. The light complies with FMVSS/CMVSS 108 requirements for combination clearance/marker light when mounted properly.

2 1/2" x 1 1/4"



Bargman/Wesbar Bulk	Bargman Clam Shell	Bargman Bagged	Wesbar Packaging	Description
	41-37-031	44-37-031	203293	Clearance Lens #37 Red w/Black Base w/Wire
	41-37-032	44-37-032	203292	Clearance Lens #37 Amber w/Black Base w/Wire
			203294	Clearance Lens #37 Amber w/Chrome Base w/Wire
			203295	Clearance Lens #37 Red w/Chrome Base w/Wire

Replacement Parts

40-37-001		40-37-401	203396	Clearance Light Module #37 Red
40-37-002		40-37-402	203395	Clearance Light Module #37 Amber
40-37-020		44-37-020		Black 2" Snap-Lock Base, Self-Grounding w/Single Black Wire
106289				Black 2" Snap-Lock Base Self-Grounding
108297				Black 2" Snap-Lock Base Open Back
106293		34-106293		Chrome 2" Snap-Lock Base Self-Grounding w/Wire
106294		34-106294		Chrome 2" Snap-Lock Base Open Back
221588				Grommet Rectangular
106334				Single Plug for Snap-Lock Base
40-00-002		44-00-002		2 Wire Pigtail w/6" Wire Lead
108663		34-108663		2 Wire Pigtail w/18" Wire Lead

WATERPROOF/SEALED CLEARANCE/ SIDE MARKER LIGHTS #38 SERIES 

Double bulb rectangular light with the polycarbonate lens sonic welded to the base. This light offers easy installation with self grounding base on metallic surfaces. Snap-lock tabs on the lens housing secures light to base to complete the fast installation. The light complies with FMVSS/CMVSS 108 requirements for combination clearance/marker light when mounted properly. P2 rated.

3 13/16" x 1 1/4"



Bargman/Wesbar Bulk	Bargman Clam Shell	Bargman Bagged	Wesbar Packaging	Description
	41-38-031	44-38-031		Clearance Lens #38 Red w/Black Base w/Wire Assembly
	41-38-032	44-38-032		Clearance Lens #38 Amber w/Black Base w/Wire Assembly
40-38-004				Fender Mount Clearance Light Module #38 Red/Amber

Accessory Parts

40-40-120				Fender Mount Black Base for Two Lights
-----------	--	--	--	--

Replacement Parts

40-38-001				Clearance Light Module #38 Red
40-38-002				Clearance Light Module #38 Amber
40-38-020				Black Base w/Wire Assembly, Self-Grounding w/Single Black Wire
40-38-025				Black Base w/2 Wires

NOTE: Tail Lights, Clearance/Side Marker Lights and ID Light Bars approved for trailer accessory and towing application use. Contact your Cequent Performance Products Representative for details.





**WATERPROOF/SEALED CLEARANCE/
SIDE MARKER LIGHTS #30 SERIES**

Clearance/side marker light with grommet designed for quick and easy installation. Rugged ABS base that has the acrylic lens sonic welded to the base. Flush mount rubber grommet and two wire pigtail can be purchased separately or as a kit. 2" dia. x 3/4", 2 3/4" dia. w/grommet, Cutout: 2 5/16" dia



Bargman/ Wesbar Bulk	Bargman Clam Shell	Bargman Bagged	Wesbar Packaging	Description
		44-30-031		Clearance Light #30 Red w/Grommet w/6" Pigtail
		44-30-032		Clearance Light #30 Amber w/Grommet w/6" Pigtail

Replacement Parts

40-30-001	41-30-001	44-30-001	203381	Clearance Light Module #30 Red
40-30-002	41-30-002	44-30-002	203380	Clearance Light Module #30 Amber
40-00-002		44-00-002		2 Wire Pigtail w/6" Wire Lead
108663		34-108663		2 Wire Pigtail w/18" Wire Lead
40-30-020		44-30-020		2" Round Grommet
			401589	2" Round Grommet and 2 Wire Pigtail w/6" Wire Lead

**WATERPROOF/SEALED CLEARANCE/
SIDE MARKER LIGHTS #31 SERIES**

Clearance/side marker light with grommet designed for quick and easy installation. Rugged ABS base that has the acrylic lens sonic welded to the base. Flush mount rubber grommet and two wire pigtail can be purchased separately or as a kit. 2 1/2" dia. x 3/4", 3 1/4" dia. w/grommet, Cutout: 2 25/32" dia.



Bargman/ Wesbar Bulk	Bargman Clam Shell	Bargman Bagged	Wesbar Packaging	Description
		44-31-031		Clearance Light #31 Red w/Grommet w/6" Pigtail
		44-31-032		Clearance Light #31 Amber w/Grommet w/6" Pigtail

Replacement Parts

40-31-001	41-31-001	44-31-001		Clearance Light Module #31 Red
40-31-002	41-31-002	44-31-002		Clearance Light Module #31 Amber
40-00-002		44-00-002		2 Wire Pigtail w/6" Wire Lead
108663		34-108663		2 Wire Pigtail w/18" Wire Lead
40-31-020		44-31-020		2 1/2" Round Grommet
221088				2 1/2" Round Open Back Heavy Duty Grommet

**WATERPROOF/SEALED CLEARANCE/
SIDE MARKER LIGHTS 2 1/2" ROUND W/REFLEX LENS**

Clearance/side marker light with grommet designed for quick and easy installation. Rugged ABS base that has the acrylic reflex lens sonic welded to the base. Flush mount rubber grommet and two wire pigtail can be purchased separately. 2 1/2" dia. x 3/4", 3 1/4" dia. w/grommet, Cutout: 2 25/32" dia.



Bargman/ Wesbar Bulk	Bargman Clam Shell	Bargman Bagged	Wesbar Packaging	Description
203224			203386	Clearance Light Module Red w/Reflex
203223			203385	Clearance Light Module Amber w/Reflex

Replacement Parts

40-00-002		44-00-002		2 Wire Pigtail w/6" Wire Lead
108663		34-108663		2 Wire Pigtail w/18" Wire Lead
40-31-020		44-31-020		2 1/2" Round Grommet
221088				2 1/2" Round Open Back Heavy Duty Grommet

NOTE: Tail Lights, Clearance/Side Marker Lights and ID Light Bars approved for trailer accessory and towing application use. Contact your Cequent Performance Products Representative for details.





WATERPROOF CLEARANCE/SIDE MARKER LIGHTS 

Sonically-sealed waterproof clearance/side marker lights with break-resistant polycarbonate lens. Available in either stud-mount or ear-mount styling. Features a pre-installed 15" pigtail. Meets FMVSS/CMVSS 108 requirements for clearance/ marker lights when properly mounted.

Stud: 2 1/8" x 1 1/8" x 1 1/16"
 Ear: 3 5/16" x 1 5/16" x 1"

Bargman/ Wesbar Bulk	Bargman Clam Shell	Bargman Bagged	Wesbar Packaging	Description
003273			203286	Clearance Light Red w/White Ear-Mount Base
003231			203234	Clearance Light Red w/White Stud-Mount Base
003239				Clearance Light Red w/Black Stud-Mount Base
003272			203285	Clearance Light Amber w/White Ear-Mount Base
003230			203233	Clearance Light Amber w/White Stud-Mount Base
003238				Clearance Light Amber w/Black Stud-Mount Base

NOTE: Tail Lights, Clearance/Side Marker Lights and ID Light Bars approved for trailer accessory and towing application use. Contact your Cequent Performance Products Representative for details.

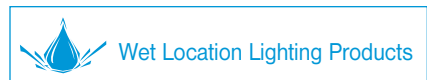



CLEARANCE/SIDE MARKER LIGHTS #58 SERIES

Clearance/side marker light has a rugged ABS base and acrylic snap-on lens. The molded socket protects bulb from road shock and has two wires to eliminate surface ground. The molded grommet extends through the skin to protect the wiring.
4" x 2" x 1 1/32" w/5/8" depth

Bargman/ Wesbar Bulk	Bargman Clam Shell	Bargman Bagged	Wesbar Packaging	Description
30-58-001		34-58-001		Clearance Light #58 Red w/White Base
30-58-002		34-58-002		Clearance Light #58 Amber w/White Base
30-58-007				Utility Light #58 Clear w/White Base

Replacement Parts

30-90-194		34-90-194		Bulb #194
30-58-102				Wedge Base Socket w/o Bulb
30-58-702		34-58-702		Wedge Base Socket w/#194 Bulb
30-58-010		34-58-010		Lens #58 Red
30-58-012		34-58-012		Lens #58 Amber
30-58-024				White Base
30-59-054		34-59-054		Gasket-Foam

CLEARANCE/SIDE MARKER LIGHTS #59 SERIES WITH REFLEX LENS



Clearance/side marker light has a rugged ABS base and acrylic snap-on reflex lens. The molded socket protects bulb from road shock and has two wires to eliminate surface ground. The molded grommet extends through the skin to protect the wiring.
4" x 2" x 1 1/32" w/5/8" depth

Bargman/ Wesbar Bulk	Bargman Clam Shell	Bargman Bagged	Wesbar Packaging	Description
30-59-001	31-59-001	34-59-001		Clearance Light #59 Red w/White Base
30-59-003				Clearance Light #59 Red w/Black Base
30-59-002	31-59-002	34-59-002		Clearance Light #59 Amber w/White Base
30-59-004				Clearance Light #59 Amber w/Black Base

Replacement Parts

30-90-194		34-90-194		Bulb #194
30-58-102				Wedge Base Socket w/o Bulb
30-58-702		34-58-702		Wedge Base Socket w/#194 Bulb
30-59-010	31-59-010	34-59-010		Lens #59 Red
30-59-012	31-59-012	34-59-012		Lens #59 Amber
30-58-024				White Base
30-59-054		34-59-054		Gasket-Foam

NOTE: Tail Lights, Clearance/Side Marker Lights and ID Light Bars approved for trailer accessory and towing application use. Contact your Cequent Performance Products Representative for details.



CLEARANCE/SIDE MARKER LIGHTS #68 SERIES WEATHERTIGHT WITH REFLEX LENS WITH FOAM GASKET



Clearance/side marker light has a low profile, one-piece construction. This light has an ABS base with an acrylic reflex lens. The two wire design eliminates surface ground.

3 7/8" x 1 13/16" x 1/2" w/1" depth

Bargman/Wesbar Bulk	Bargman Clam Shell	Bargman Bagged	Wesbar Packaging	Description
30-68-510		34-68-510		Clearance Light #68 Red w/Foam Gasket
30-68-511		34-68-511		Clearance Light #68 Amber w/Foam Gasket
30-68-503		34-68-503		Utility Light #68 Clear

Replacement Parts

30-90-194		34-90-194		Bulb #194
30-58-702		34-58-702		Wedge Base Socket w/#194 Bulb
30-68-729				Lens #68 Red & Base Assembly
30-68-730				Lens #68 Clear & Base Assembly
30-68-731				Lens #68 Amber & Base Assembly
30-68-054		34-68-054		Gasket-Foam
30-68-047		34-68-047		Gasket-Fiber

CLEARANCE/SIDE MARKER LIGHTS #178 SERIES WEATHERTIGHT WITH REFLEX LENS



Clearance/side marker light has a low profile, one-piece construction with radius styling, ABS base and an acrylic reflex lens. The two wire design eliminates surface ground.

3 7/8" x 1 7/8" x 3/4" w/3/4" depth

Bargman/Wesbar Bulk	Bargman Clam Shell	Bargman Bagged	Wesbar Packaging	Description
30-17-814		34-17-808		Clearance Light #178 Red w/White Base w/14" Wires
30-17-815		34-17-809		Clearance Light #178 Amber w/White Base w/14" Wires

Replacement Parts

30-90-194		34-90-194		Bulb #194
30-58-702		34-58-702		Wedge Base Socket w/#194 Bulb
30-17-034		34-17-034		Gasket-Foam

CLEARANCE/SIDE MARKER LIGHTS #678 SERIES WITH REFLEX LENS



Low profile, radius styled clearance/side marker lights. Snap-on reflex lens. Base and two wire harness are a one piece, easy to install, assembly. Meets all applicable FMVSS/CMVSS 108 requirements.

3 7/8" x 1 7/8" x 3/4" w/3/4" depth

Bargman/Wesbar Bulk	Bargman Clam Shell	Bargman Bagged	Wesbar Packaging	Description
	31-67-808	34-67-808		Clearance Light #678 Red w/White Base
	31-67-809	34-67-809		Clearance Light #678 Amber w/White Base

Replacement Parts

30-90-194		34-90-194		Bulb #194
30-67-801		34-67-801		Lens Red, Clearance Light
30-67-802		34-67-802		Lens Amber, Clearance Light

NOTE: Tail Lights, Clearance/Side Marker Lights and ID Light Bars approved for trailer accessory and towing application use. Contact your Cequent Performance Products Representative for details.



CLEARANCE/SIDE MARKER LIGHTS #478 SERIES WITH REFLEX LENS

Clearance/side marker light has an ABS base with an acrylic snap-on reflex lens and built-in drain hole. This unit is ready for surface mounting with quick connect wiring installation for supply wire and is self-grounding.

4" x 2" x 1"

Bargman/ Wesbar Bulk	Bargman Clam Shell	Bargman Bagged	Wesbar Packaging	Description
30-47-801		34-47-801		Clearance Light #478 Red w/Colonial White Base
30-47-803		34-47-803		Clearance Light #478 Red w/White Base
30-47-802		34-47-802		Clearance Light #478 Amber w/Colonial White Base
30-47-804		34-47-804		Clearance Light #478 Amber w/White Base

Replacement Parts

30-48-095		34-48-095		Bulb #57/#1895
30-47-811		34-47-811		Lens #478 Red
30-47-812		34-47-812		Lens #478 Amber



CLEARANCE/SIDE MARKER LIGHTS #400 SERIES

Clearance/side marker light has an ABS base with an acrylic snap-on lens and built-in drain hole. This unit is ready for surface mounting with quick connect wiring installation for supply wire and is self-grounding.

4" x 2" x 1"

Bargman/ Wesbar Bulk	Bargman Clam Shell	Bargman Bagged	Wesbar Packaging	Description
30-40-001		34-40-001		Clearance Light #400 Red w/Colonial White Base
30-40-002		34-40-002		Clearance Light #400 Amber w/Colonial White Base

Replacement Parts

30-48-095		34-48-095		Bulb #57/#1895
30-40-011		34-40-011		Lens #400 Red
30-40-012		34-40-012		Lens #400 Amber

CLEARANCE/SIDE MARKER LIGHTS WITH REFLEX LENS

Featuring quick connect wiring installation, these lights feature hidden mounting hardware. Includes snap-fit reflex lens. Meets FMVSS/CMVSS 108 requirements for clearance/marker lights when properly mounted. PC rated.

3 3/4" x 2 1/4" x 15/16"



Bargman/ Wesbar Bulk	Bargman Clam Shell	Bargman Bagged	Wesbar Packaging	Description
			203264	Clearance Light Red w/White Base
			203263	Clearance Light Amber w/White Base

Replacement Parts

30-90-194		34-90-194		Bulb #194
003240			003378	Lens Amber, Clearance Light
003243				White Base w/Bulb

NOTE: Tail Lights, Clearance/Side Marker Lights and ID Light Bars approved for trailer accessory and towing application use. Contact your Cequent Performance Products Representative for details.

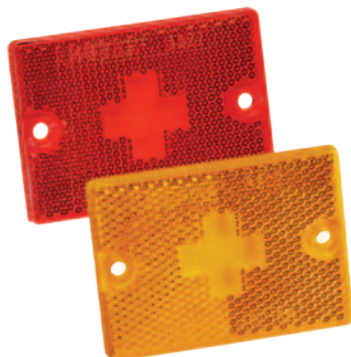

CLEARANCE/SIDE MARKER LIGHTS WITH REFLEX LENS

Stud mount clearance/side marker light with reflex lens and 18" wire lead. Includes a tapered base for easy installation.

2 3/4" x 2" x 1"

Bargman/Wesbar Bulk	Bargman Clam Shell	Bargman Bagged	Wesbar Packaging	Description
			203116	Clearance Light Red
223117			203117	Clearance Light Amber

Replacement Parts

108891				Bulb #193
003327				Lens Red, Clearance Light
		90-03-327	003337	Lens Red, Clearance Light w/Screws
003328				Lens Amber, Clearance Light
		90-03-328	003338	Lens Amber, Clearance Light w/Screws

CLEARANCE/SIDE MARKER LIGHTS WITH REFLEX LENS

Featuring reflex lens and quick connect wiring installation, these lights are available with stud-mount or ear-mount styling.

3 1/8" x 2 3/8" x 1"



Bargman/Wesbar Bulk	Bargman Clam Shell	Bargman Bagged	Wesbar Packaging	Description
003103			203113	Clearance Light Red w/Black Stud-Mount Base
003123			203133	Clearance Light Red w/Black Ear-Mount Base
003101			203111	Clearance Light Amber w/Black Stud-Mount Base
003121			203131	Clearance Light Amber w/Black Ear-Mount Base

Replacement Parts

30-48-095		34-48-095		Bulb #57/#1895
003327				Lens Red, Clearance Light
		90-03-327	003337	Lens Red, Clearance Light w/Screws
003328				Lens Amber, Clearance Light
		90-03-328	003338	Lens Amber, Clearance Light w/Screws

NOTE: Tail Lights, Clearance/Side Marker Lights and ID Light Bars approved for trailer accessory and towing application use. Contact your Cequent Performance Products Representative for details.



CLEARANCE/SIDE MARKER LIGHT #41 SERIES

Rectangular low profile clearance/side marker light with attractive chrome plated ABS base. The two wire design eliminates surface ground. The molded grommet extends through the skin to protect the wiring.

3 3/4" x 2 1/4" x 1/2" w/1 1/8" depth.

Bargman/ Wesbar Bulk	Bargman Clam Shell	Bargman Bagged	Wesbar Packaging	Description
40-41-001		44-41-001		Clearance Light #41 Red

Replacement Parts

30-90-194		34-90-194		Bulb #194
-----------	--	-----------	--	-----------

CLEARANCE/SIDE MARKER LIGHT WITH REFLEX LENS

Meets FMVSS/CMVSS 108 requirements for clearance/marker lights when properly mounted ("PC" rated). Features quick connect wiring installation.

2 3/4" x 2 7/8" x 1 1/4"



Bargman/ Wesbar Bulk	Bargman Clam Shell	Bargman Bagged	Wesbar Packaging	Description
003141			003148	Clearance Light Amber

Replacement Parts

30-48-095		34-48-095		Bulb #57/#1895
			003318	Lens Amber, Clearance Light

CLEARANCE/SIDE MARKER LIGHT

Clearance/side marker light featuring quick connect wiring installation with stud mounting. Meets FMVSS/CMVSS 108 requirements for clearance/marker lights when properly mounted ("PC" rated).

2 1/4" x 2 1/4" x 1 1/4"



Bargman/ Wesbar Bulk	Bargman Clam Shell	Bargman Bagged	Wesbar Packaging	Description
003225			203235	Clearance Light Amber

Replacement Parts

30-48-095		34-48-095		Bulb #57/#1895
003330			003340	Lens Amber, Clearance Light

NOTE: Tail Lights, Clearance/Side Marker Lights and ID Light Bars approved for trailer accessory and towing application use. Contact your Cequent Performance Products Representative for details.



MINI CLEARANCE/SIDE MARKER LIGHT #39 SERIES

Clearance/side marker light with acrylic snap-on lens and built-in drain hole. Single wire construction, self-grounding with double catching lens holders. White base.

3 3/16" x 1 1/32" x 1 1/16"

Bargman/Wesbar Bulk	Bargman Clam Shell	Bargman Bagged	Wesbar Packaging	Description
40-39-001		44-39-001		Clearance Light #39 Red

Replacement Parts

30-90-194		34-90-194		Bulb #194
-----------	--	-----------	--	-----------



CLEARANCE/SIDE MARKER LIGHTS #100 SERIES

Round clearance/side marker light has a rugged ABS base and an acrylic snap-on lens. This unit is ready for surface mounting with quick connect wiring installation for supply wire and is self-grounding.

2 3/8" dia. x 1"

Bargman/Wesbar Bulk	Bargman Clam Shell	Bargman Bagged	Wesbar Packaging	Description
30-50-101		34-50-101		Clearance Light #100 Red w/Col. White Base
30-50-102		34-50-102		Clearance Light #100 Amber w/Col. White Base

Replacement Parts

30-48-095		34-48-095		Bulb #57/#1895
30-50-111		34-50-111		Lens #100 Red, Clearance Light
30-50-112		34-50-112		Lens #100 Amber, Clearance Light



CLEARANCE/SIDE MARKER LIGHT 2 3/4" ROUND

Surface mount round clearance/side marker light. Single wire construction and self-grounding.

2 3/4" dia. x 1"

Bargman/Wesbar Bulk	Bargman Clam Shell	Bargman Bagged	Wesbar Packaging	Description
30-073836		34-073836		Clearance Light Amber, Self-Grounding w/Single Black Wire

Replacement Parts

30-90-194		34-90-194		Bulb #194
30-173836				Lens Amber, Clearance Light



CLEARANCE/SIDE MARKER LIGHT 2 3/4" ROUND

Round clearance/side marker light with surface mount design. Two wire construction simplifies grounding. These lights meet FMVSS-108 and CMVSS-108 requirements for P2 and PC side marker clearance functions when properly mounted.

2 3/4" Round

Bargman/Wesbar Bulk	Bargman Clam Shell	Bargman Bagged	Wesbar Packaging	Description
30-073833		34-073833		Clearance Light Red Round w/Two Wire Construction
30-073834		34-073834		Clearance Light Amber Round w/Two Wire Construction

Replacement Parts

108891				Bulb #193
--------	--	--	--	-----------

NOTE: Tail Lights, Clearance/Side Marker Lights and ID Light Bars approved for trailer accessory and towing application use. Contact your Cequent Performance Products Representative for details.



CLEARANCE/SIDE MARKER LIGHTS #99 SERIES WITH REFLEX LENS



Clearance/side marker light has an acrylic snap-on reflex lens. This unit is ready for mounting on a flat surface with quick connect wiring installation for supply and ground wires.

4 1/16" x 1 3/8" x 1"

Bargman/Wesbar Bulk	Bargman Clam Shell	Bargman Bagged	Wesbar Packaging	Description
30-99-001	31-99-001	34-99-001		Clearance Light #99 Red
30-99-002	31-99-002	34-99-002		Clearance Light #99 Amber

Accessory Parts

40-40-120				Two Light Fender Mount Bezel
-----------	--	--	--	------------------------------

Replacement Parts

30-48-095		34-48-095		Bulb #57/#1895
30-99-010		34-99-010		Lens #99 Red, Clearance Light
30-99-012		34-99-012		Lens #99 Amber, Clearance Light



CLEARANCE/SIDE MARKER LIGHTS FENDER MOUNT #40 SERIES

Dual function red/amber light for use on fender mount applications. The bulb is protected by the lens on all sides. Two wire design (24" supply and ground) eliminates surface ground. Light w/black base, stainless steel mounting screws: 3.65" x 1.25" x 1.45" w/.5" depth

Light only: 2.75" x 1" x .85" w/.5" depth

Fender mount bezel only: 7.20" x 4.85" x .85"

Bargman/Wesbar Bulk	Bargman Clam Shell	Bargman Bagged	Wesbar Packaging	Description
40-40-004		44-40-004		Fender Mount Clearance Light #40 Red/Amber w/Lexan® Black Base, Includes Stainless Steel Mounting Screws
40-40-104				Fender Mount Clearance Light Red/Amber

Accessory Parts

40-40-115				Fender Mount Bezel
-----------	--	--	--	--------------------



CLEARANCE/SIDE MARKER LIGHT FENDER MOUNT

Surface mount dual function red/amber light with black base for use on fender mount applications. The bulb is protected by the lens on all sides. Two wire design (18" supply and ground) eliminates surface ground.

3.5" x .78" x 1.03"

Bargman/Wesbar Bulk	Bargman Clam Shell	Bargman Bagged	Wesbar Packaging	Description
40-40-006				Fender Mount Clearance Light Red/Amber w/Black Base

Replacement Parts

30-90-194		34-90-194		Bulb #194
-----------	--	-----------	--	-----------

NOTE: Tail Lights, Clearance/Side Marker Lights and ID Light Bars approved for trailer accessory and towing application use. Contact your Cequent Performance Products Representative for details.



DUAL BULB CLEARANCE/SIDE MARKER LIGHTS

Lights specifically designed for heavy-duty and industrial use. Features a polycarbonate lens. Pre-wired with a 6" supply lead and are self-grounding. 4" x 2" x 1 1/8"



Bargman/Wesbar Bulk	Bargman Clam Shell	Bargman Bagged	Wesbar Packaging	Description
003441	32-003441			Clearance Light Red
003440	32-003440			Clearance Light Amber

Replacement Parts

108891				Bulb #193
108844		34-108844	003495	Lens Red, Clearance Light
108843			003494	Lens Amber, Clearance Light

NOTE: Tail Lights, Clearance/Side Marker Lights and ID Light Bars approved for trailer accessory and towing application use. Contact your Cequent Performance Products Representative for details.

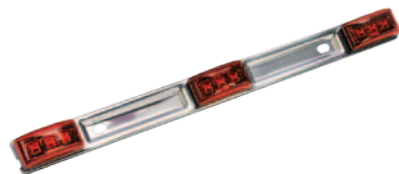

WATERPROOF LED ID LIGHT BAR

Light bar with three waterproof red lights. Stainless steel base with stud mounting. 14 1/4" x 1 3/16" x 1 1/16"

Bargman/Wesbar Bulk	Bargman Clam Shell	Bargman Bagged	Wesbar Packaging	Description
47-99-004		47-99-034	401567	Light Bar LED w/Red Lens

Replacement Parts

47-99-005			401566	Clearance Light LED #99 Red
-----------	--	--	--------	-----------------------------



WATERPROOF LED ID LIGHT BAR

Waterproof LED low profile red light bar. This light meets FMVSS/CMVSS 108 requirements for vehicles 80" wide or wider. Prewired, single bullet supply and ring terminal ground, with 60" harness for easy installation. P2 rated.

13.54" x 1.313" x .787"

Bargman/Wesbar Bulk	Bargman Clam Shell	Bargman Bagged	Wesbar Packaging	Description
47-106858			42-106858	Light Bar LED w/Red Lens



WATERPROOF LED ID LIGHT BAR

Submersible design with black poly-carbonate base incorporates LED #37 series clearance/marker modules. Prewired (supply and ring terminal ground) for easy installation. FMVSS/CMVSS 108 P2 compliant for use to meet over 80" rear clearance marking requirements.

17" x 1.46" x 1.69"

Bargman/Wesbar Bulk	Bargman Clam Shell	Bargman Bagged	Wesbar Packaging	Description
47-99-215	42-99-215			Light Bar LED w/Red Lens

Replacement Parts

47-37-001	42-37-401	47-37-401	401581	Clearance Light Module LED #37 Red
-----------	-----------	-----------	--------	------------------------------------



LED ID LIGHT BAR WITH REFLEX LENS

This LED light bar with 3 diodes is designed for a narrow rail surface mounting. Features include built-in reflex reflectors and stainless steel grommeted mounting holes. Prewired (supply and ground) for easy installation.

15.84" x 2.29" - Mounting holes on 14.49" centers

Bargman/Wesbar Bulk	Bargman Clam Shell	Bargman Bagged	Wesbar Packaging	Description
47-54-002				Light Bar LED w/Red Lens
47-54-003				Light Bar LED w/Amber Lens

NOTE: Tail Lights, Clearance/Side Marker Lights and ID Light Bars approved for trailer accessory and towing application use. Contact your Cequent Performance Products Representative for details.





WATERPROOF ID LIGHT BAR 

Light bar with three sonically-sealed, impact-resistant polycarbonate lens and housing that ensure a waterproof module. Light bar features a stainless steel base. 16 1/2" x 1 3/8" x 1 1/2"

Bargman/Wesbar Bulk	Bargman Clam Shell	Bargman Bagged	Wesbar Packaging	Description
003309			203309	Light Bar w/Red Lens

Replacement Parts

40-37-001		40-37-401	203396	Clearance Light Module #37 Red
40-37-002		40-37-402	203395	Clearance Light Module #37 Amber



WATERPROOF ID LIGHT BAR 

Submersible design with black poly-carbonate base incorporates incandescent #37 series clearance/marker modules. FMVSS/CMVSS 108 P2 compliant for use to meet over 80" rear clearance marking requirements.

17" x 1.46" x 1.69"

Bargman/Wesbar Bulk	Bargman Clam Shell	Bargman Bagged	Wesbar Packaging	Description
30-99-215	31-99-215			Red ID Bar Incandescent

Replacement Parts

40-37-001		40-37-401	203396	Clearance Light Module #37 Red
-----------	--	-----------	--------	--------------------------------



WATERPROOF ID LIGHT BARS 

Sonically-sealed, impact-resistant polycarbonate lens and housing ensure a waterproof module. Meet or exceed all applicable state and federal regulations specified for vehicles 80" wide or wider. Three sealed polycarbonate lamps on 6" centers lead to a stainless steel base completing the best line up of waterproof light bars available today. #003305 and #003306 are pre-wired with 60" leads and can be mounted in protected areas because of their low profile.

14-1/2" x 1-1/8" x 1"

Bargman/Wesbar Bulk	Bargman Clam Shell	Bargman Bagged	Wesbar Packaging	Description
003305			203315	Light Bar w/Red Waterproof Modules (White Bases)
003306				Light Bar w/Red Waterproof Modules (Black Bases)

NOTE: Tail Lights, Clearance/Side Marker Lights and ID Light Bars approved for trailer accessory and towing application use. Contact your Cequent Performance Products Representative for details.





ID LIGHT BAR

Zinc-plated bar with pre-wired clearance lights. Features quick connect wiring installation.

14 1/2" x 2 1/4" x 1 1/2"

Bargman/ Wesbar Bulk	Bargman Clam Shell	Bargman Bagged	Wesbar Packaging	Description
003301				Light Bar w/ Amber Lens

Replacement Parts

30-48-095		34-48-095		Bulb #57/#1895
003330			003340	Lens Amber, Clearance Light



ID LIGHT BAR

Three lights with acrylic lens and ABS housing mounted on a white steel bar.

Bargman/ Wesbar Bulk	Bargman Clam Shell	Bargman Bagged	Wesbar Packaging	Description
30-073843		34-073843		Red ID Bar



LOW PROFILE ID LIGHT BAR

Light bar with three impact-resistant polycarbonate lens. Black painted steel bar is pre-wired with a 6" lead for easy installation. Low profile design allows mounting options.

16 1/2" x 1 3/8" x 1 1/2"

Bargman/ Wesbar Bulk	Bargman Clam Shell	Bargman Bagged	Wesbar Packaging	Description
003310			203310	Light Bar w/Red Lens

Replacement Parts

108891				Bulb #193
108284				Lens Red, Light Bar

NOTE: Tail Lights, Clearance/Side Marker Lights and ID Light Bars approved for trailer accessory and towing application use. Contact your Cequent Performance Products Representative for details.



IDENTIFICATION LIGHTS ONLY 

Three (3) #194 wedge base bulbs. Individual bulb output is 2 CP at .27 amps with 14 vdc supply. Bulbs are spaced on 7.50" centers (to comply with FMVSS CMVSS 108). All three bulbs are recessed inside shrouds to produce an overall effect of one lens with three individual light sources (per FMVSS/CMVSS 108 requirements). Parallel wiring ensures bulbs will continue to work if one burns out. Meets SAE Recommended Practice J592 for photometric requirements. Available with red or amber lens (front and rear applications). Molded-in grommet to satisfy ANSI A119.2 /NFPA 501C and NEC 551-10 section c. **UL listed for wet locations.** Traditional screw mounting option. See sketch for mounting and dimensions.

Bargman/Wesbar Bulk	Bargman Clam Shell	Bargman Bagged	Wesbar Packaging	Description
30-99-101				Rear-Red Lens w/White Base
30-99-201				Rear-Red lens w/Black Base
30-99-102				Front-Amber Lens w/White Base

Replacement Parts

30-90-194		34-90-194		Bulb #194
30-99-040				ID Bar Lens Red
30-99-042				ID Bar Lens Amber
30-84-075				Lens Screw

CENTER HIGH MOUNT STOP LAMP (CHMSL) ONLY 

SAE U2 supplemental center high mounted stop lamp. Two (2) #922 wedge base bulbs. Individual bulb output is 6 CP at .69 amps with 13 vdc supply for CHMSL. When applying CHMSL to trailer, a brake module (must be obtained from a separate supplier) must be wired in series to the positive (+) CHMSL wire. Parallel wiring ensures either bulb will continue to work if one bulb burns out. Molded-in grommet to satisfy ANSI A119.2 /NFPA 501C and NEC 551-10 section c. **UL listed for wet locations.** Traditional screw mounting option. See sketch for mounting and dimensions.

Bargman/Wesbar Bulk	Bargman Clam Shell	Bargman Bagged	Wesbar Packaging	Description
30-99-114				CHMSL w/White Base
30-99-214				CHMSL w/Black Base

Replacement Parts

30-90-022		34-90-022		Bulb #922
30-99-040				ID Bar Lens Red
30-99-042				ID Bar Lens Amber
30-84-075				Lens Screw

NOTE: Tail Lights, Clearance/Side Marker Lights and ID Light Bars approved for trailer accessory and towing application use. Contact your Cequent Performance Products Representative for details.





IDENTIFICATION LIGHTS WITH HALOGEN SPOT LIGHTS



IDENTIFICATION LIGHTS: Three (3) #194 wedge base bulbs. Individual bulb output is 2 CP at .27 amps with 14 vdc supply. Bulbs are spaced on 7.50" centers (to comply with FMVSS/CMVSS 108). All three bulbs are recessed inside shrouds to produce an overall effect of one lens with three individual light sources (per FMVSS/CMVSS 108 requirements). Meets SAE Recommended Practice J592 for photometric requirements. Parallel wiring ensures bulbs will continue to work if one burns out. Available with red lens (rear applications). HALOGEN SPOT LIGHTS: Dual MR-16, 35-Watt halogen bulbs with 38-degree beam spread. Provides enough light for the average person to be able to read a magazine at a distance of nine feet from the halogen lights. Halogen bulbs wired to BOTH lose illumination if one burns out. Easy, three-wire connection: positive wire for ID Lights, positive wire for Halogen Spots, common ground. Molded-in grommet to satisfy ANSI A119.2 / NFPA 501C and NEC 551-10 section c. **UL listed for wet locations.** Traditional screw mounting option. See sketch for mounting and dimensions.

Bargman/Wesbar Bulk	Bargman Clam Shell	Bargman Bagged	Wesbar Packaging	Description
30-99-111				Rear-Red Lens w/Spot w/White Base
30-99-211				Rear-Red Lens w/Spot w/Black Base

Replacement Parts

30-90-194		34-90-194		Bulb #194
30-90-016				Bulb Halogen MR-16
30-99-050				ID Bar Lens Red w/Spot
30-84-075				Lens Screw

IDENTIFICATION LIGHT BARS WITH HALOGEN SPOT LIGHTS WIRING DIAGRAM

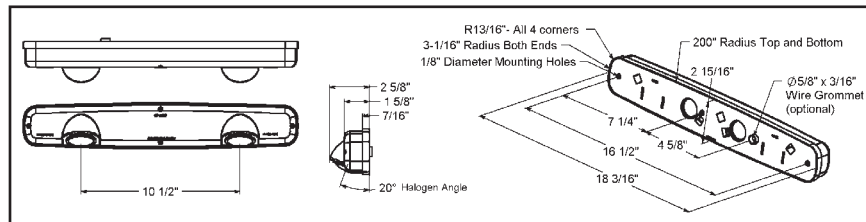

NOTE: Tail Lights, Clearance/Side Marker Lights and ID Light Bars approved for trailer accessory and towing application use. Contact your Cequent Performance Products Representative for details.

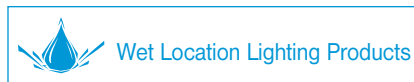



LICENSE PLATE LIGHTS #62 SERIES

License plate light with ABS body construction. The light is available in black or white. Can be purchased with or without the separate 18 gauge galvanized steel license bracket. The molded socket protects bulb from road shock and has two wires to eliminate surface ground.

4" x 1 1/2" x 2 5/8"

Bargman/Wesbar Bulk	Bargman Clam Shell	Bargman Bagged	Wesbar Packaging	Description
30-62-003		34-62-003		License Light w/Bracket White
30-62-103		34-62-103		License Light Less Bracket White
30-62-002		34-62-002		License Light w/Bracket Black
30-62-102		34-62-102		License Light Less Bracket Black

Replacement Parts

30-90-168		34-90-168		Bulb #168
30-62-030		34-62-030		License Plate Bracket



LICENSE PLATE LIGHT

License light and black steel bracket. Self-grounding, single wire construction.

Bargman/Wesbar Bulk	Bargman Clam Shell	Bargman Bagged	Wesbar Packaging	Description
223215		34-223215		License Plate Light w/Bracket

Replacement Parts

30-90-194		34-90-194		Bulb #194
-----------	--	-----------	--	-----------



30-62-000

30-073837

LICENSE PLATE LIGHTS

Durable license plate illuminators that are dirt and moisture resistant. Housing is chrome plated steel with half shaded white lens. Mini Compact light features two wire construction, mounting gasket and screw. Bullet Snap-in light with self-grounding single wire construction.

2 5/8" x 1 1/4" x 1" - Mini Compact

1" cutout - Bullet Snap-in

Bargman/Wesbar Bulk	Bargman Clam Shell	Bargman Bagged	Wesbar Packaging	Description
30-62-000		34-62-000		Mini Compact Light
30-073837				Bullet Snap-in License Light

Replacement Parts

30-90-194		34-90-194		Bulb #194
-----------	--	-----------	--	-----------

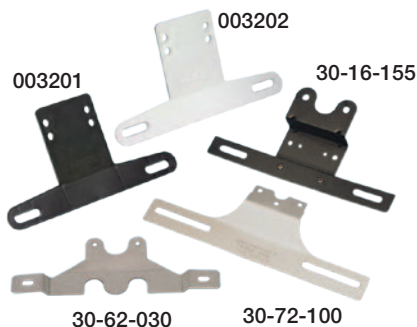

003201

003202

30-16-155

30-62-030

30-72-100

LICENSE PLATE BRACKETS

Bargman/Wesbar Bulk	Bargman Clam Shell	Bargman Bagged	Wesbar Packaging	Description
30-16-155				Black Enamel License Plate Bracket #1500 Series Lights
30-62-030		34-62-030		License Plate Bracket 18 Gauge, Galvanized Steel
30-72-100		34-72-100		License Plate Bracket 16 Gauge, Zinc Plated
003201			003211	License Plate Bracket Plastic, Black
003202		34-003202	003213	License Plate Bracket Plastic, White

NOTE: Tail Lights, Clearance/Side Marker Lights and ID Light Bars approved for trailer accessory and towing application use. Contact your Cequent Performance Products Representative for details.



BRACKET

Dark brown thermo-plastic corner bracket. .20" dia. mounting holes accept up to #10 screws.

1" X 1" X 1" - 45° angled



Bargman/ Wesbar Bulk	Bargman Clam Shell	Bargman Bagged	Wesbar Packaging	Description
60-50-001		64-50-001		Support Mounting Bracket

WATERPROOF LICENSE LIGHT

Waterproof, sealed license plate light with #193 bulb for a variety of mounting applications. Pigtail available separately. Meets FMVSS/CMVSS 108 requirements.



Bargman/ Wesbar Bulk	Bargman Clam Shell	Bargman Bagged	Wesbar Packaging	Description
223210				License Plate Light and Bracket Assembly (requires 2 Wire Pigtail)

Accessory Parts

40-00-002		44-00-002		2 Wire Pigtail w/6" Wire Lead
108663		34-108663		2 Wire Pigtail w/18" Wire Lead

Replacement Parts

106310				License Light Module Clear
--------	--	--	--	----------------------------

NOTE: Tail Lights, Clearance/Side Marker Lights and ID Light Bars approved for trailer accessory and towing application use. Contact your Cequent Performance Products Representative for details.





OBLONG/RECTANGULAR REFLECTORS

Oblong: Class "A" acrylic reflector, hermetically sealed, with two mounting holes. Optional adhesive fiber back.
4 3/8" X 1 7/8"



Bargman/Wesbar Bulk	Bargman Clam Shell	Bargman Bagged	Wesbar Packaging	Description
70-78-010	71-78-010	74-78-010		Red w/Mounting Holes & Adhesive Back
70-78-050				Red w/Mounting Holes Only
70-78-020	71-78-020	74-78-020		Amber w/Mounting Holes & Adhesive Back
70-78-060				Amber w/Mounting Holes Only

Rectangular: Class "A" acrylic reflector, hermetically sealed, with an adhesive fiber back for instant mounting.
3 1/4" X 1 1/2"

Bargman/Wesbar Bulk	Bargman Clam Shell	Bargman Bagged	Wesbar Packaging	Description
70-71-180		74-71-180	003358	Red w/Adhesive Back
70-71-181		74-71-181	003357	Amber w/Adhesive Back
323357				Amber w/Adhesive Back, w/Mounting Holes (4 3/8" X 1 1/4")
323356				Red w/Adhesive Back, w/Mounting Holes (4 3/8" X 1 1/4")

CONSPICUITY REFLECTORS/TAPE

Reflectors meet or exceed DOT-C and SAE J5941 for reflectivity marking on trucks and trailers. Reflectors are comparable in light return to the 2" x 12" reflective tape and hermetically sealed.

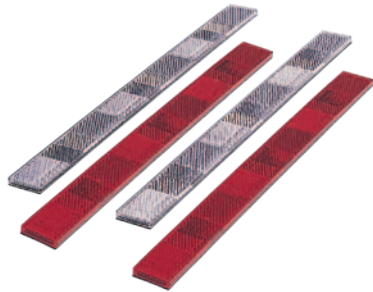

Conspicuity Reflectors - 1.1" X 12"

Bargman/Wesbar Bulk	Bargman Clam Shell	Bargman Bagged	Wesbar Packaging	Description
		74-72-040		Clear & Red w/Adhesive Back
70-72-020		74-72-020	003387	Clear w/Adhesive Back
70-72-030		74-72-030	003388	Red w/Adhesive Back

ROUND REFLECTORS

Class "A" acrylic reflector, hermetically sealed. Center mounting hole or adhesive fiber back.
3 3/16" & 2 3/16"

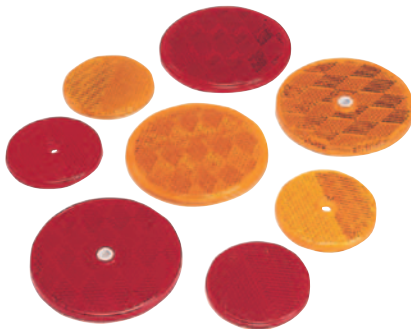

Bargman/Wesbar Bulk	Bargman Clam Shell	Bargman Bagged	Wesbar Packaging	Description
70-68-010		74-68-010		3 3/16" Red w/Center Mounting Hole
70-71-170		74-71-170		2 3/16" Red w/Center Mounting Hole
70-68-020		74-68-020		3 3/16" Amber w/Center Mounting Hole
70-71-175		74-71-175		2 3/16" Amber w/Center Mounting Hole
70-38-010		74-38-010		3 3/16" Red w/Adhesive Back
70-55-010	71-55-010	74-55-010		2 3/16" Red w/Adhesive Back
70-38-020		74-38-020		3 3/16" Amber w/Adhesive Back
70-55-020	71-55-020	74-55-020		2 3/16" Amber w/Adhesive Back

NOTE: Tail Lights, Clearance/Side Marker Lights and ID Light Bars approved for trailer accessory and towing application use. Contact your Cequent Performance Products Representative for details.



PORCH/UTILITY LIGHTS #78 SERIES

This compact design is surface mounted with either polypropylene or chrome plated ABS base and either a clear or amber snap-in lens. A remote switch is required. Two wire construction, supply and ground. CSA approved.

5 15/16" x 3 1/2" x 2"

Bargman/Wesbar Bulk	Bargman Clam Shell	Bargman Bagged	Wesbar Packaging	Description
30-78-515	31-78-531	34-78-515		White w/Clear Lens
30-78-522				Black w/Clear Lens
30-78-600				Chrome w/Clear Lens
30-78-516	31-78-532	34-78-516		White w/Amber Lens
30-78-523				Black w/Amber Lens

Replacement Parts

30-90-041		34-90-041		Bulb #1141 (After mid 2007)
30-78-021		34-78-021		Lens #78 Clear
30-78-022		34-78-022		Lens #78 Amber



PORCH/UTILITY LIGHTS #78 SERIES WITH SWITCH

This compact exterior light with black rocker switch is designed for surface mounting. Polypropylene base has a lens that is snap-in and is available in either clear or amber. Two wire construction, supply and ground. CSA approved.

5 15/16" x 3 1/2" x 2"

Bargman/Wesbar Bulk	Bargman Clam Shell	Bargman Bagged	Wesbar Packaging	Description
30-78-517		34-78-517		White w/Switch w/Clear Lens
30-78-524				Black w/ Switch w/Clear lens
30-78-518		34-78-518		White w/Switch w/Amber Lens
30-78-525				Black w/Switch w/Amber Lens

Replacement Parts

30-90-041		34-90-041		Bulb #1141 (After mid 2007)
30-78-021		34-78-021		Lens #78 Clear
30-78-022		34-78-022		Lens #78 Amber

NOTE: Tail Lights, Clearance/Side Marker Lights and ID Light Bars approved for trailer accessory and towing application use. Contact your Cequent Performance Products Representative for details.



PORCH/UTILITY LIGHTS #80 SERIES

Medallion style 12 volt surface mounted porch light. ABS housing with removable clear or amber acrylic lens. A remote switch is required. Two wire construction, supply and ground. CSA listed for surface wall mounting.

5.54" x 5.50" x 2.28"



Bargman/Wesbar Bulk	Bargman Clam Shell	Bargman Bagged	Wesbar Packaging	Description
30-80-001				White Base w/Clear Lens
30-80-002				White Base w/Amber Lens
30-80-005				Black Base w/Clear Lens

Replacement Parts

30-90-041		34-90-041		Bulb #1141
30-80-021				Lens #80 Clear
30-80-022				Lens #80 Amber

PORCH/UTILITY LIGHT #80 SERIES WITH SWITCH

Medallion style 12 volt surface mounted porch light with switch. ABS housing with removable clear or amber acrylic lens. Two wire construction, supply and ground. CSA listed for surface wall mounting.

5.54" x 5.50" x 2.28"



Bargman/Wesbar Bulk	Bargman Clam Shell	Bargman Bagged	Wesbar Packaging	Description
30-80-003				White Base w/ Switch w/Clear Lens
30-80-004				White Base w/Switch w/Amber Lens
30-80-007				Black Base w/Switch w/Clear Lens

Replacement Parts

30-90-041		34-90-041		Bulb #1141
30-80-021				Lens #80 Clear
30-80-022				Lens #80 Amber

SECURITY/UTILITY LIGHTS

This 12 volt surface mounted light is designed to flood light in all directions. The light adds the benefit of increased security features to any unit. Features a 7" polycarbonate lens, two wire construction and stainless steel base to resist corrosion. Designed for years of trouble-free service featuring a gasket between the lens and base, as well as a gasket for mounting.

8 3/4" dia.



Bargman/Wesbar Bulk	Bargman Clam Shell	Bargman Bagged	Wesbar Packaging	Description
40-60-001				Security/Utility Light
40-60-004				Security/Utility Light-White Painted Base

Replacement Parts

30-90-156				Bulb #1156, Single Filament
-----------	--	--	--	-----------------------------

NOTE: Tail Lights, Clearance/Side Marker Lights and ID Light Bars approved for trailer accessory and towing application use. Contact your Cequent Performance Products Representative for details.



PORCH/UTILITY LIGHTS #80 SERIES

This 12 volt surface mounted porch light is a heavy duty oval shape. ABS base with clear or amber acrylic lens that are snap-in design. Two wire construction, supply and ground. CSA approved.

6 1/4" x 3 1/2" x 2"



Bargman/Wesbar Bulk	Bargman Clam Shell	Bargman Bagged	Wesbar Packaging	Description
30-79-003				White w/Clear Lens
30-79-004				White w/Amber Lens

Replacement Parts

30-79-023				Lens #79 Clear
30-79-024				Lens #79 Amber
30-90-041		34-90-041		Bulb #1141

PORCH/UTILITY LIGHTS #79 SERIES WITH SWITCH

This 12 volt surface mounted porch light is a heavy duty oval shape. ABS base with clear or amber acrylic lens that are snap-in design. Available with black rocker switch. Two wire construction, supply and ground. CSA approved.

6 1/4" x 3 1/2" x 2"



Bargman/Wesbar Bulk	Bargman Clam Shell	Bargman Bagged	Wesbar Packaging	Description
30-79-005				White w/Switch w/Clear Lens
30-79-006				White w/Switch w/Amber Lens

Replacement Parts

30-79-023				Lens #79 Clear
30-79-024				Lens #79 Amber
30-90-041		34-90-041		Bulb #1141

ASSIST BARS LIGHTED

Zinc die cast assist bar available in chrome or black finish with stamped aluminum back plate. A polypropylene lens provides a diffused light that lights up the entrance area. Available with or without push-button switch and has two wire construction, supply and ground. CSA approved.

Cutout: 4 9/16" x 7 5/8"

Overall: 5 3/4" x 8 7/8" x 7/8" w/ 13/16" depth



Bargman/Wesbar Bulk	Bargman Clam Shell	Bargman Bagged	Wesbar Packaging	Description
70-32-001		74-32-001		Assist Bar Lighted w/Switch Chrome
70-32-006				Assist Bar Lighted w/Switch Black
70-32-002		74-32-002		Assist Bar Lighted less Switch Chrome

Replacement Parts

30-90-041		34-90-041		Bulb #1141
70-32-030		74-32-030		Lens Assist Bar Lighted
70-32-041				Switch Assist Bar Lighted
70-32-042				Rubber Boot Assist Bar Lighted
		74-32-041		Switch w/Rubber Boot Assist Bar Lighted

NOTE: Tail Lights, Clearance/Side Marker Lights and ID Light Bars approved for trailer accessory and towing application use. Contact your Cequent Performance Products Representative for details.



INTERIOR LIGHTS #76 SERIES

Single or double 12 volt interior light with diffused lens optics. Double light is available with single or dual switch. Two wire construction, supply and ground. Features a polypropylene base. CSA listed/ approved for ceiling mount and specific wall mounts. Contact your Cequent Representative for the specific wall mount applications.

7.28" x 4.33" x 1.78"
11.02" x 4.33" x 1.78"

Bargman/Wesbar Bulk	Bargman Clam Shell	Bargman Bagged	Wesbar Packaging	Description
30-76-123	3176123	34-76-123		Single Light #76 w/Switch
30-76-223		34-76-223		Double Light #76 w/Switch
30-76-243		34-76-243		Double Light #76 w/Dual Switch
30-76-173				Single Light #76 w/Switch w/Jack
30-76-273				Double Light #76 w/Switch w/Jack

Replacement Parts

30-90-021		34-90-021		Bulb #921
30-76-028		34-76-028		Lens #76



BUNK LIGHT / BUNK LIGHT OUTLET #76 SERIES

Flexible source of light that will allow you to get light to otherwise dark areas of fold down campers and other 12 volt vehicles. Its compact size allows for easy storage when not in use. An eight foot coiled power supply cord is built in. The light can be powered from an optional Bunk Light Outlet when the OEM has not used the Bargman #76 series interior light with a built-in jack. The Bunk Light Outlet mounts next to an existing light to tap into the present 12 volt power source.

7.28" x 4.33" x 1.78"

Bargman/Wesbar Bulk	Bargman Clam Shell	Bargman Bagged	Wesbar Packaging	Description
30-76-144				Single Light #76 w/Switch w/Cord
30-93-152		34-93-152		Outlet, w/Jack

Replacement Parts

30-90-021		34-90-021		Bulb #921
30-76-028		34-76-028		Lens #76



INTERIOR DOME LIGHT 5" ROUND W/CHROME BASE

Chrome plated steel base with clear polycarbonate lens. Two wire construction (supply and ground) for easy installation. **Non UL/CSA, suitable for utility use in cargo trailers.**

6.43" dia. x 1.65"

Bargman/Wesbar Bulk	Bargman Clam Shell	Bargman Bagged	Wesbar Packaging	Description
30-60-004				Interior Dome Light 5" Round w/Chrome Base
30-60-005				Interior Dome Light 5" Round w/Chrome Base w/Switch

Replacement Parts

30-90-156				Bulb #1156
-----------	--	--	--	------------

NOTE: Tail Lights, Clearance/Side Marker Lights and ID Light Bars approved for trailer accessory and towing application use. Contact your Cequent Performance Products Representative for details.



UTILITY LIGHT #15 SERIES

Surface mount light with foam gasket features two wire construction and has a full cover lens that allows light to diffuse in all directions. The switch is mounted in the lens to keep the unit as compact as possible.

4 9/16" x 2 1/2" x 1 3/4"

Bargman/ Wesbar Bulk	Bargman Clam Shell	Bargman Bagged	Wesbar Packaging	Description
40-15-005		44-15-005		Utility Light Clear w/Switch

Replacement Parts

30-90-156				Bulb #1156
-----------	--	--	--	------------

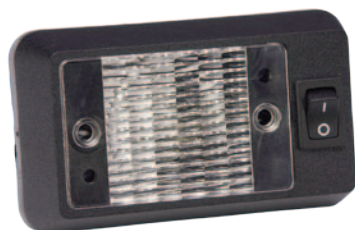

UTILITY LIGHT

Utility light with ABS housing.

4 1/8" x 2 3/8" x 1"

Bargman/ Wesbar Bulk	Bargman Clam Shell	Bargman Bagged	Wesbar Packaging	Description
30-073813		34-073813		Interior Light 4" x 2.37" W/Switch

Replacement Parts

30-90-194		34-90-194		Bulb #194
-----------	--	-----------	--	-----------

NOTE: Tail Lights, Clearance/Side Marker Lights and ID Light Bars approved for trailer accessory and towing application use. Contact your Cequent Performance Products Representative for details.



2' & 4' WESBAR PLANOGRAMS

- Best Selling Items
- Designed for 2' or 4' Wide x 4' High Areas
- Minimum Inventory for Maximum Turn
- Includes Reorder Cards

Note: Does not include display or hooks.



2' Wesbar Planogram - LED

54311-002

Plan-o-gram Includes All Items Shown



**4' Wesbar
Planogram -
Incandescent/
Electrical**

54311-001

Plan-o-gram Includes All Items Shown



WESBAR LED 2' PLANOGRAM - 54311-002

Part No.	Description	Qty
LED - ROW #1 - LEFT TO RIGHT		
401565	LED Waterproof Marker/Clearance Lamp, Stud Mount, Amber	2
401566	LED Waterproof Marker/Clearance Lamp, Stud Mount, Red	2
54201-001	LED Clearance Light Amber w/Chrome Bezel (47-106853 & 47-106020)	2
54201-002	LED Clearance Light Red w/Chrome Bezel (47-107047 & 47-106020)	2
54005	LED 6" Oval Courtesy Light Clear w/Grommet w/Pigtail	2
42-106858	LED Light Bar w/Red Lens	2
LED - ROW #2 - LEFT TO RIGHT		
401580	LED Waterproof Marker/Clearance Lamp, Amber	2
401581	LED Waterproof Marker/Clearance Lamp, Red	2
401576	LED Waterproof Marker/Clearance Lamp, 2" Round Grommet Mount, Amber	2
401577	LED Waterproof Marker/Clearance Lamp, 2" Round Grommet Mount, Red	2
401578	LED Waterproof Marker/Clearance Lamp, 2 1/2" Round Grommet Mount, Amber	2
401579	LED Waterproof Marker/Clearance Lamp, 2 1/2" Round Grommet Mount, Red	2
LED - ROW #3 - LEFT TO RIGHT		
407535	LED Waterproof Stop, Turn and Tail lamp, Roadside	2
407530	LED Waterproof Stop, Turn and Tail lamp, Curbside	2
281595	LED - Wrap-Around 8-Function, Roadside	2
281594	LED - Wrap-Around 7-Function, Curbside	2
LED - ROW #4 - LEFT TO RIGHT		
54006	LED 6" Oval Tail Light Red w/Grommet w/Pigtail	2
54004	LED 6" Oval Tail Light Red w/Chrome Trim Snap Ring	2
407555	LED Waterproof STL-80 Stop, Turn, and Tail Lamp, Roadside	2
407550	LED Waterproof STL-80 Stop, Turn, and Tail Lamp, Curbside	2
401567	LED Waterproof ID Light Bar	2
LED - ROW #5 - LEFT TO RIGHT		
407540	LED Waterproof Low Profile Trailer Light Kit	1
407560	LED Waterproof STL-80 Trailer Light Kit	1
287512	LED Submersible Under 80" Trailer Light Kit	1

WESBAR INCANDESCENT/ELECTRICAL 4' PLANOGRAM - 54311-001

Part No.	Description	Qty
INCANDESCENT - ROW #1 - LEFT TO RIGHT		
203131	Clearance Marker Lamp w/Reflector, Amber	2
203133	Clearance Marker Lamp w/Reflector, Red	2
203111	Clearance Marker Light, Amber	2
203113	Clearance Marker Light, Red	2
203292	Sealed Clearance Marker Lamp, Amber	2
203293	Sealed Clearance Marker Lamp, Red	2
003148	Clearance Marker Lamp Amber w/Reflex Reflector, PC Rated	2
403348	Sealed Bulb Replacement Tail Lamp Capsule	2
403080	Sealed Oval Tail Lamp Kit	2
203309	Waterproof ID Bar, Chrome, Red	2
003211	Black Plastic License Plate Bracket	2
INCANDESCENT - ROW #2 - LEFT TO RIGHT		
203395	Sealed Clearance Marker Lamp Module Snap-Lock, Amber	2
203396	Sealed Clearance Marker Lamp Module Snap-Lock, Red	2
203233	Waterproof Clearance Marker Lamp, Stud Mount, Amber	2
203234	Waterproof Clearance Marker Lamp, Stud Mount, Red	2
203294	Sealed Clearance Marker Lamp, Amber	2
203295	Sealed Clearance Marker Lamp, Red	2
ELECTRICAL - ROW #2		
707254	Double Ended 4-Way 2ft.	2
707255	Double Ended 5-Way 2ft.	2
INCANDESCENT - ROW #3 - LEFT TO RIGHT		
2523024	Submersible Over 80" Tail Light, Roadside	2
2523074	Submersible Over 80" Tail Light, Curbside	2
403025	Submersible Over 80" Tail Light, Roadside	2
403075	Submersible Over 80" Tail Light, Curbside	2
403087	Sealed Oval Lamp Module, Clear	2
403085	Sealed Oval Tail Lamp Module, Red	2
ELECTRICAL - ROW #3		
707250	7-Way to 5-Way Adapter	2
767940	Adapter - 7-Way Blade to 5-Way Flat	2
767941	4-Way Tester w/LED	2
767942	5-Way Tester w/LED and Dust Cap	2
INCANDESCENT - ROW #4 - LEFT TO RIGHT		
2523023	Submersible Under 80" Tail Lamp, Roadside	2
2523073	Submersible Under 80" Tail Lamp, Curbside	2
403026	Waterproof Over 80" Low Profile Tail Lamp, Roadside	2
403076	Waterproof Over 80" Low Profile Tail Lamp, Curbside	2
ELECTRICAL - ROW #4		
707261	25' 4-Flat Wishbone Wire Harness Kit	2
707270	4-Way Trunk/Trailer Connector Kit, 66"	2
707272	4-Way Trunk Connector 6' with 6' Ground	2
707286	4-Way Trailer Connector, 18" Wishbone	2
707275	4-Way Trunk Connector, 4' with 18" Ground	2
INCANDESCENT - ROW #5 - LEFT TO RIGHT		
2527511	Submersible, Under 80" Trailer Light Kit	1
007509	Waterproof Low Profile Trailer Light Kit	1
ELECTRICAL - ROW #5		
707105	25' 5-Flat Wishbone Wire Harness Kit	2
707273	5-Way Trunk Connector, 6' with 4' Ground	2
707283	5-Way Trunk Connector 4' with 4' Ground	2

NOTE: Tail Lights, Clearance/Side Marker Lights and ID Light Bars approved for trailer accessory and towing application use. Contact your Cequent Performance Products Representative for details.

BARGMAN LED /INCANDESCENT LIGHTING PLANOGRAM



Offering a complete display of the best selling LED and Incandescent interior and exterior lighting products. Planograms are designed for areas 2' wide x 4' high, 3' wide x 4' high and 4' wide x 4' high.

- LPOG31001** 4' Wide Bargman LED/Incandescent Interior/Exterior Planogram
- LPOG31002** 2' Wide Bargman LED Exterior Planogram
- LPOG31003** 3' Wide Bargman Incandescent Interior/Exterior Planogram



Note: Does not include display or hook.

NOTE: Tail Lights, Clearance/Side Marker Lights and ID Light Bars approved for trailer accessory and towing application use. Contact your Cequent Performance Products Representative for details.

BARGMAN LED/INCANDESCENT INTERIOR/EXTERIOR LIGHTING PLANOGRAM
DETAILED PRODUCT CONTAINED IN PLANOGRAM LPOG31001, 4' X 4' BY ROW

Part No.	Description	Qty
INCANDESCENT - ROW #1 - LEFT TO RIGHT (TOP)		
41-30-001	Clearance Light Module #30 2" Red	3
41-30-002	Clearance Light Module #30 2" Amber	3
41-31-001	Clearance Light Module #31 2-1/2" Red	3
41-31-002	Clearance Light Module #31 2-1/2" Amber	3
41-37-031	Clearance Lens #37 Red w/Black Base w/Wire	3
41-37-032	Clearance Lens #37 Amber w/Black Base w/Wire	3
31-78-531	Porch/Utility Light #78 White w/Clear Lens	2
31-78-532	Porch/Utility Light #78 White w/Amber Lens	2
LED - ROW #1 - LEFT TO RIGHT (TOP)		
42-30-401	LED Clearance Light Module #30 2" Red	3
42-30-402	LED Clearance Light Module #30 2" Amber	3
42-31-403	LED Clearance Light Module #31 2-1/2" Red w/Reflex	3
42-31-404	LED Clearance Light Module #31 2-1/2" Amber w/Reflex	3
42-86-410	LED Upgrade Red Clearance Light Wrap-Around #86 Light Module	3
42-86-412	LED Upgrade Amber Clearance Light Wrap-Around #86 Light Module	3
INCANDESCENT - ROW #2 - LEFT TO RIGHT		
31-59-001	Clearance Light #59 Red w/White Base	3
31-59-002	Clearance Light #59 Amber w/White Base	3
32-003441	Clearance Light Dual Bulb Red	3
32-003440	Clearance Light Dual Bulb Amber	3
41-38-031	Clearance Lens #38 Red w/Black Base w/Wire	3
41-38-032	Clearance Lens #38 Amber w/Black Base w/Wire	3
LED - ROW #2 - LEFT TO RIGHT		
42-59-401	LED Clearance Light #59 Red w/White Base w/Pigtail	3
42-59-402	LED Clearance Light #59 Amber w/White Base w/Pigtail	3
42-59-410	LED Upgrade Red Clearance Light #59 Lens Module	3
42-59-412	LED Upgrade Amber Clearance Light #59 Lens Module	3
42-38-033	LED Clearance Light #38 Red w/Black Base w/Pigtail	3
42-38-034	LED Clearance Light #38 Amber w/Black Base w/Pigtail	3
INCANDESCENT - ROW #3 - LEFT TO RIGHT		
31-67-808	Clearance Light #678 Red w/White Base	3
31-67-809	Clearance Light #678 Amber w/White Base	3
31-99-001	Clearance Light #99 Red	3
31-99-002	Clearance Light #99 Amber	3
31-59-010	Red Lens #59	3
31-59-012	Amber Lens #59	3
3176123	Interior Light #76 Single White	1
3176123	Interior Light #76 Single White	1
LED - ROW #3 - LEFT TO RIGHT		
42-37-401	LED Clearance Light Module #37 Red	3
42-37-402	LED Clearance Light Module #37 Amber	3
42-99-401	LED Clearance Light #99 Red	3
42-99-402	LED Clearance Light #99 Amber	3
42-42-401	LED Clearance Light #42 Red	3
42-42-402	LED Clearance Light #42 Amber	3
INCANDESCENT - ROW #4 - LEFT TO RIGHT		
31-84-010	Red Lens #84/85/86	2
31-84-016	Amber Lens #84/85/86	2
31-92-001	Stop/Tail/Turn #92 Surface Mount w/White Base	2
31-92-003	Stop/Tail/Turn #92 Surface Mount w/License Light & Brkt w/White Base	2
LED - ROW #4 - LEFT TO RIGHT		
42-84-410	LED Upgrade Red Stop/Tail/Turn Module #84/85/86	2
42-84-412	LED Upgrade Amber Turn Module #84/85/86	2
42-84-414	LED Upgrade Backup Lens Module #84/85/86	2

Part No.	Description	Qty
INCANDESCENT - ROW #5 - LEFT TO RIGHT (TOP)		
31-84-700	Backup Lens #84/85/86 - Lens Mounted Vertical	2
31-84-711	Backup Lens #84/85/86 - Lens Mounted Horizontal	2
LED - ROW #5 - LEFT TO RIGHT (TOP)		
42-86-101	LED Stop/Tail/Turn #86 Red w/Black Base	2
42-86-104	LED Turn #86 Amber w/Black Base	2
71-78-010	Reflector Red w/Mounting Holes & Adhesive Back	3
71-78-020	Reflector Amber w/Mounting Holes & Adhesive Back	3
71-55-010	Reflector Red 2-3/16" w/Adhesive Back	3
71-55-020	Reflector Amber 2-3/16" w/Adhesive Back	3
INCANDESCENT - ROW #6 - LEFT TO RIGHT		
31-86-101	Stop/Tail/Turn #86 Red w/Black Base	2
31-86-104	Turn #86 Amber w/Black Base	2
31-86-103	Backup Vertical Mount #86 w/Black Base	2
31-2823285	Trailer Light Kit Under 80" w/25 Ft. Wire Harness	2
LED - ROW #6 - LEFT TO RIGHT		
31-407560	LED Trailer Light Kit 4x6 Waterproof Low Profile	1
31-407540	LED Trailer Light Kit 3x8 Waterproof Low Profile	1

NOTE: Tail Lights, Clearance/Side Marker Lights and ID Light Bars approved for trailer accessory and towing application use. Contact your Cequent Performance Products Representative for details.



BARGMAN LED EXTERIOR LIGHTING PLANOGRAM

DETAILED PRODUCT CONTAINED IN PLANOGRAM LPOG31002, 2' X 4' BY ROW

Part No.	Description	Qty
LED - ROW #1 - LEFT TO RIGHT (TOP)		
42-30-401	LED Clearance Light Module #30 2" Red	3
42-30-402	LED Clearance Light Module #30 2" Amber	3
42-31-403	LED Clearance Light Module #31 2-1/2" Red w/Reflex	3
42-31-404	LED Clearance Light Module #31 2-1/2" Amber w/Reflex	3
42-86-410	LED Upgrade Red Clearance Light Wrap-Around #86 Light Module	3
42-86-412	LED Upgrade Amber Clearance Light Wrap-Around #86 Light Module	3
LED - ROW #2 - LEFT TO RIGHT		
42-59-401	LED Clearance Light #59 Red w/White Base w/Pigtail	3
42-59-402	LED Clearance Light #59 Amber w/White Base w/Pigtail	3
42-59-410	LED Upgrade Red Clearance Light #59 Lens Module	3
42-59-412	LED Upgrade Amber Clearance Light #59 Lens Module	3
42-38-033	LED Clearance Light #38 Red w/Black Base w/Pigtail	3
42-38-034	LED Clearance Light #38 Amber w/Black Base w/Pigtail	3
LED - ROW #3 - LEFT TO RIGHT		
42-37-401	LED Clearance Light Module #37 Red	3
42-37-402	LED Clearance Light Module #37 Amber	3
42-99-401	LED Clearance Light #99 Red	3
42-99-402	LED Clearance Light #99 Amber	3
42-42-401	LED Clearance Light #42 Red	3
42-42-402	LED Clearance Light #42 Amber	3
LED - ROW #4 - LEFT TO RIGHT		
42-84-410	LED Upgrade Red Stop/Tail/Turn Module #84/85/86	2
42-84-412	LED Upgrade Amber Turn Module #84/85/86	2
42-84-414	LED Upgrade Backup Lens Module #84/85/86	2
LED - ROW #5 - LEFT TO RIGHT (TOP)		
42-86-101	LED Stop/Tail/Turn #86 Red w/Black Base	2
42-86-104	LED Turn #86 Amber w/Black Base	2
71-78-010	Reflector Red w/Mounting Holes & Adhesive Back	3
71-78-020	Reflector Amber w/Mounting Holes & Adhesive Back	3
71-55-010	Reflector Red 2-3/16" w/Adhesive Back	3
71-55-020	Reflector Amber 2-3/16" w/Adhesive Back	3
LED - ROW #6 - LEFT TO RIGHT		
31-407560	LED Trailer Light Kit 4x6 Waterproof Low Profile	1
31-407540	LED Trailer Light Kit 3x8 Waterproof Low Profile	1

BARGMAN INCANDESCENT INTERIOR/ EXTERIOR LIGHTING PLANOGRAM

DETAILED PRODUCT CONTAINED IN PLANOGRAM LPOG31003, 3' X 4' BY ROW

Part No.	Description	Qty
INCANDESCENT - ROW #1 - LEFT TO RIGHT (TOP)		
41-30-001	Clearance Light Module #30 2" Red	3
41-30-002	Clearance Light Module #30 2" Amber	3
41-31-001	Clearance Light Module #31 2-1/2" Red	3
41-31-002	Clearance Light Module #31 2-1/2" Amber	3
41-37-031	Clearance Lens #37 Red w/Black Base w/Wire	3
41-37-032	Clearance Lens #37 Amber w/Black Base w/Wire	3
31-78-531	Porch/Utility Light #78 White w/Clear Lens	2
31-78-532	Porch/Utility Light #78 White w/Amber Lens	2
INCANDESCENT - ROW #2 - LEFT TO RIGHT		
31-59-001	Clearance Light #59 Red w/White Base	3
31-59-002	Clearance Light #59 Amber w/White Base	3
32-003441	Clearance Light Dual Bulb Red	3
32-003440	Clearance Light Dual Bulb Amber	3
41-38-031	Clearance Lens #38 Red w/Black Base w/Wire	3
41-38-032	Clearance Lens #38 Amber w/Black Base w/Wire	3
INCANDESCENT - ROW #3 - LEFT TO RIGHT		
31-67-808	Clearance Light #678 Red w/White Base	3
31-67-809	Clearance Light #678 Amber w/White Base	3
31-99-001	Clearance Light #99 Red	3
31-99-002	Clearance Light #99 Amber	3
31-59-010	Red Lens #59	3
31-59-012	Amber Lens #59	3
3176123	Interior Light #76 Single White	1
3176123	Interior Light #76 Single White	1
INCANDESCENT - ROW #4 - LEFT TO RIGHT		
31-84-010	Red Lens #84/85/86	2
31-84-016	Amber Lens #84/85/86	2
31-92-001	Stop/Tail/Turn #92 Surface Mount w/White Base	2
31-92-003	Stop/Tail/Turn #92 Surface Mount w/License Light & Brkt w/White Base	2
INCANDESCENT - ROW #5 - LEFT TO RIGHT (TOP)		
31-84-700	Backup Lens #84/85/86 - Lens Mounted Vertical	2
31-84-711	Backup Lens #84/85/86 - Lens Mounted Horizontal	2
INCANDESCENT - ROW #6 - LEFT TO RIGHT		
31-86-101	Stop/Tail/Turn #86 Red w/Black Base	2
31-86-104	Turn #86 Amber w/Black Base	2
31-86-103	Backup Vertical Mount #86 w/Black Base	2
31-2823285	Trailer Light Kit Under 80" w/25 Ft. Wire Harness	2

NOTE: Tail Lights, Clearance/Side Marker Lights and ID Light Bars approved for trailer accessory and towing application use. Contact your Cequent Performance Products Representative for details.

BULB SPECIFICATION

BULB TYPE	PART #	PACKAGING	MEAN SPHERICAL	RATED AMPS CANDLE POWER	WATTS
#1141	30-90-041	Bulk	21	1.44	18.432
	34-90-041	Bagged			
#1156	30-90-156	Bulk	32	2.10	26.880
#1157	30-90-157	Bulk	32/3	2.10/0.59	26.880/8.260
#168	30-90-168	Bulk	3	0.35	4.900
	34-90-168	Bagged			
#193	108891	Bulk	2	0.33	4.620
#194	30-90-194	Bulk	2	0.27	3.780
	34-90-194	Bagged			
#2057	30-84-057	Bulk	32/2	2.10/0.48	26.880/6.720
#57 / #1895	30-48-095	Bulk	2	0.27	3.780
	34-48-095	Bagged			
#921	30-90-021	Bulk	21	1.40	17.920
	34-90-021	Bagged			
#922	30-90-022	Bulk	15	0.98	12.544
	34-90-022	Bagged			
MR16	30-90-016	Bulk	-	-	35

NOTE: Tail Lights, Clearance/Side Marker Lights and ID Light Bars approved for trailer accessory and towing application use. Contact your Cequent Performance Products Representative for details.

LIGHTING TERMINOLOGY

"Over 80" Combination Tail Lights

These units meet seven or eight DOT-108 lighting requirements when properly mounted. Seven function units meet tail light, stop light, rear turn signal light, rear reflex reflector, rear side marker light, rear side reflex reflector and rear clearance light. The eighth function met is license plate light. Trailers over 80 inches wide require the addition of front Clearance Lights and Rear Identification (ID) Lights. Consult Title 49 – Code of Federal Regulations-Section 571.108 (USA) or Section 108 of the Motor Vehicle Safety Regulations (Canada) for additional compliance requirements.

"Under 80" Combination Tail Lights

These units meet six or seven DOT-108 lighting requirements when properly mounted. Six function units meet tail light, stop light, rear turn signal light, rear reflex reflector, rear side marker light and rear side reflex reflector. The seventh function met is license plate light. Consult Title 49 – Code of Federal Regulations-Section 571.108 (USA) or Section 108 of the Motor Vehicle Safety Regulations (Canada) for additional compliance requirements.

"PC" Rated Clearance/Side Marker Lights

A single unit meets DOT-108 lighting requirements and has been photometrically certified at a specific installation angle to provide both clearance light and side marker light. In most cases, the light will have to be mounted on a 45° angle, Consult Title 49 – Code of Federal Regulations-Section 571.108 (USA) or Section 108 of the Motor Vehicle Safety Regulations (Canada) for additional compliance requirements to meet both functions' requirements with just one unit.

BASIC EQUIPMENT REQUIRED ON ALL TRAILERS, TRUCKS, BUSES & MPVS

Federal Motor Vehicle Safety Standards and Regulations

The tables summarize lighting equipment requirements contained in Federal/Canada Motor Vehicle Safety Standard 108.

While Cequent Performance Products, Inc. believes this to be an accurate summary of the latest printed information, the actual standard should be consulted for design or other such purposes.

For complete compliance requirements consult Title 49 - Code of Federal Regulations-Section 571.108 (USA) or Section 108 of the Motor Vehicle Safety Regulations (Canada). State or Provincial regulations, where they may apply, have not been included.

For more information contact:

Transport Canada, Motor Vehicle Safety Enforcement Branch
<http://www.tc.gc.ca>

National Highway Traffic Safety Administration, Office of Safety Performance Standards
<http://www.nhtsa.dot.gov>

TECHNICAL INFORMATION IS CURRENT AS OF THE PRINTING OF THIS CATALOG. CONTACT TECHNICAL SERVICE FOR PERIODIC UPDATES.

TRAILERS: FEDERAL LIGHTING EQUIPMENT LOCATION REQUIREMENTS

IMPORTANT NOTE: Every lamp, reflex reflector, and conspicuity treatment must be permanently attached in the location specified below and must comply with all applicable requirements prescribed for it by FMVSS/CMVSS 108. The face of any device on the front/rear and sides should be, respectively perpendicular and parallel to the vehicle's centerline, unless it is photometrically certified at installation

angle. No part of the vehicle shall prevent any device from meeting its prescribed requirements unless an auxiliary device meeting all prescribed requirements is installed. In Canada: Manufacturers and importers of vehicles must have the proper certification test records demonstrating compliance of lighting components with all prescribed requirements.

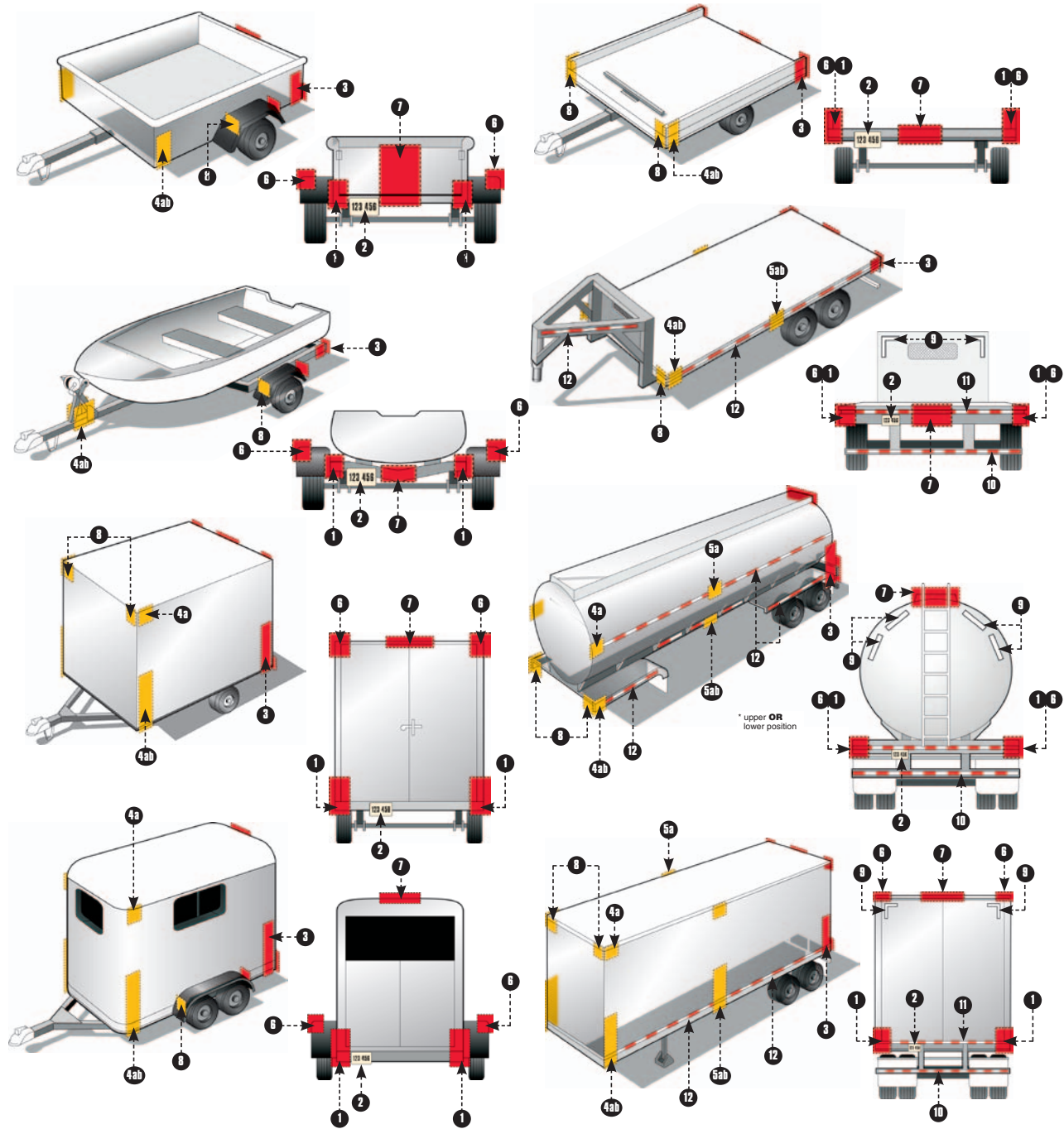

This table summarizes lighting equipment requirements contained in Federal/Canada Motor Vehicle Safety Standard 108. While Cequent Performance Products believes this to be an accurate summary of the latest printed information, the actual standard should be consulted for design or other such purposes. For complete compliance requirements consult Title 49 - Code of Federal Regulations-Section 571.108 (USA) or Section 108 of the Motor Vehicle Safety Regulations (Canada). State or Provincial regulations, where they may apply, have not been included.

For more information contact:
 Transport Canada, Motor Vehicle Safety Enforcement Branch
<http://www.tc.gc.ca>
 National Highway Traffic Safety Administration, Office of Safety Performance Standards
<http://www.nhtsa.dot.gov>

BASIC EQUIPMENT REQUIRED ON ALL TRAILERS

DESCRIPTION				MANDATORY REQUIREMENTS			
Area	Equipment	SAE Lens Coding	Functional Purpose	Quantity	Color	Location	Height mm(in.) from the ground
1	Tail Lamps	(T)	Indicate vehicle's presence and width	Minimum 2	Red	On the rear - symmetrical as far apart as practicable	380-1830 (15-72)
	Stop Lamps	(S)	Indicate braking	Minimum 2	Red	On the rear - symmetrical as far apart as practicable	380-1830 (15-72)
	Rear Turn Signal Lamps	(I)	Indicate direction of turn	Minimum 2	Red or Yellow	On the rear - symmetrical as far apart as practicable	380-2110 (15-83)
	Rear Reflex Reflectors	(A)	Indicate vehicle's presence and width	Minimum 2	Red	On the rear - symmetrical as far apart as practicable facing rearward	380-1530 (15-60)
2	License Plate Lamp(s)	(L)	Illuminates license plate	Minimum 1	White	On the rear - above or at the sides of license plate	No requirement
3	Rear Side Marker Lamps <small>*photometrically certified at installation angle</small>	(P2, PC* or P3, PC2*)	Front and rear side marker lamps / side reflex reflectors indicate vehicle's presence and length	Minimum 2	Red	Each side at rear as far back as practicable	380-1530 (15-60) no max. for veh. under 2032mm (80") wide
	Rear Side Reflex Reflectors	(A)		Minimum 2	Red	Each side at rear as far back as practicable facing sideward	380-1530 (15-60)
4	a Front Side Marker Lamps <small>*photometrically certified at installation angle</small>	(P2, PC* or P3, PC2*)	Front and rear side marker lamps / side reflex reflectors indicate vehicle's presence and length	Minimum 2	Yellow	Each side at front as far forward as practicable	380 (15) minimum
	b Front Side Reflex Reflectors	(A)		Minimum 2	Yellow	Each side at front as far forward as practicable facing sideward	380-1530 (15-60)

ADDITIONAL EQUIPMENT FOR TRAILERS EXCEEDING THE FOLLOWING PARAMETERS
Length 9.1m (30 ft.) or longer

DESCRIPTION				MANDATORY REQUIREMENTS			
Area	Equipment	SAE Lens Coding	Functional Purpose	Quantity	Color	Location	Height mm(in.) from the ground
5	a Intermediate Side Marker Lamps	(P2 or P3)	Indicate presence of a long vehicle	Minimum 2	Yellow	Each side near center facing sideward	380 (15) minimum
	b Intermediate Side Reflex Reflectors	(A)	Indicate presence of a long vehicle	Minimum 2	Yellow	Each side near center facing sideward	380-1530 (15-60)

Width 2032mm (80 in.) or wider

DESCRIPTION			MANDATORY REQUIREMENTS				
Area	Equipment	SAE Lens Coding	Functional Purpose	Quantity	Color	Location	Height
6	Rear Clearance Lamps <small>*photometrically certified at installation angle</small>	(P2, PC* or P3, PC2*)	Show vehicle's width MAY NOT be combined with tail lamps	Minimum 2	Red	At widest point - symmetrical on the rear or near the rear facing rearward	As high as practicable may be lower only if ID lamps are at the top
7	Rear Identification (ID) Lamps	(P2 or P3)	Indicate presence of a wide vehicle	Exactly 3	Red	On the rear - center horizontally spaced 150mm (6 in.) to 300mm (12 in.) apart facing rearward	At the top - may be lower if door header narrower than 25mm
8	Front Clearance Lamps <small>*photometrically certified at installation angle</small>	(P2, PC* or P3, PC2*)	Show vehicle's width	Minimum 2	Yellow	At widest point - symmetrical on the front or near the front facing forward	As high as practicable

Width 2032mm (80 in.) or wider AND GVWR 4536 kg (10,000 lb.) or more

DESCRIPTION		MANDATORY REQUIREMENTS					
Area	Conspicuity Treatment	DOT Coding	Quantity	Color	Location	Height	Options
9	Rear Upper Body Markings	<div style="border: 1px solid black; padding: 2px; display: inline-block;"> DOT-C DOT-C2 DOT-C3 DOT-C4 </div>	Exactly 2 pairs of 300mm long strips	White	On the rear upper corners facing rearward	At the top	Reflex reflectors may not be required if they are replaced in their required location with conspicuity treatment. Optional in Canada: Rear lower body and side conspicuity treatment may also be solid white, solid yellow, or white and yellow.
10	Bumper Bar Marking		Continuous	Red/White	On the rear bumper bar's horizontal element full width - facing rearward	No requirement	
11	Rear Lower Body Marking		Continuous	Red/White <i>(see options)</i>	On the rear full width of the vehicle facing rearward	As horizontal as practicable and as close as practicable to the range of 375 to 1525mm from the ground	
12	Side Marking		(see location)	Red/White <i>(see options)</i>	Each side - facing sideward continuous, or evenly spaced over minimum of 50% of length starts and ends as close to the front and rear of the vehicle as practicable	As horizontal as practicable and as close as practicable to the range of 375 to 1525mm from the ground	

NOTE: The edge of red conspicuity tape shall not be closer than 75 mm to the edge of any amber lamp and the edge of white conspicuity tape shall not be closer than 75 mm to the edge of any lamp

TRUCKS: FEDERAL LIGHTING EQUIPMENT LOCATION REQUIREMENTS

IMPORTANT NOTE: Every lamp, reflex reflector, and conspicuity treatment must be permanently attached in the location specified below and must comply with all applicable requirements prescribed for it by FMVSS/CMVSS 108. The face of any device on the front/rear and sides should be, respectively perpendicular and parallel to the vehicle's centerline, unless it is photometrically

certified at installation angle. No part of the vehicle shall prevent any device from meeting its prescribed requirements unless an auxiliary device meeting all prescribed requirements is installed. In Canada: Manufacturers and importers of vehicles must have the proper certification test records demonstrating compliance of lighting components with all prescribed requirements.

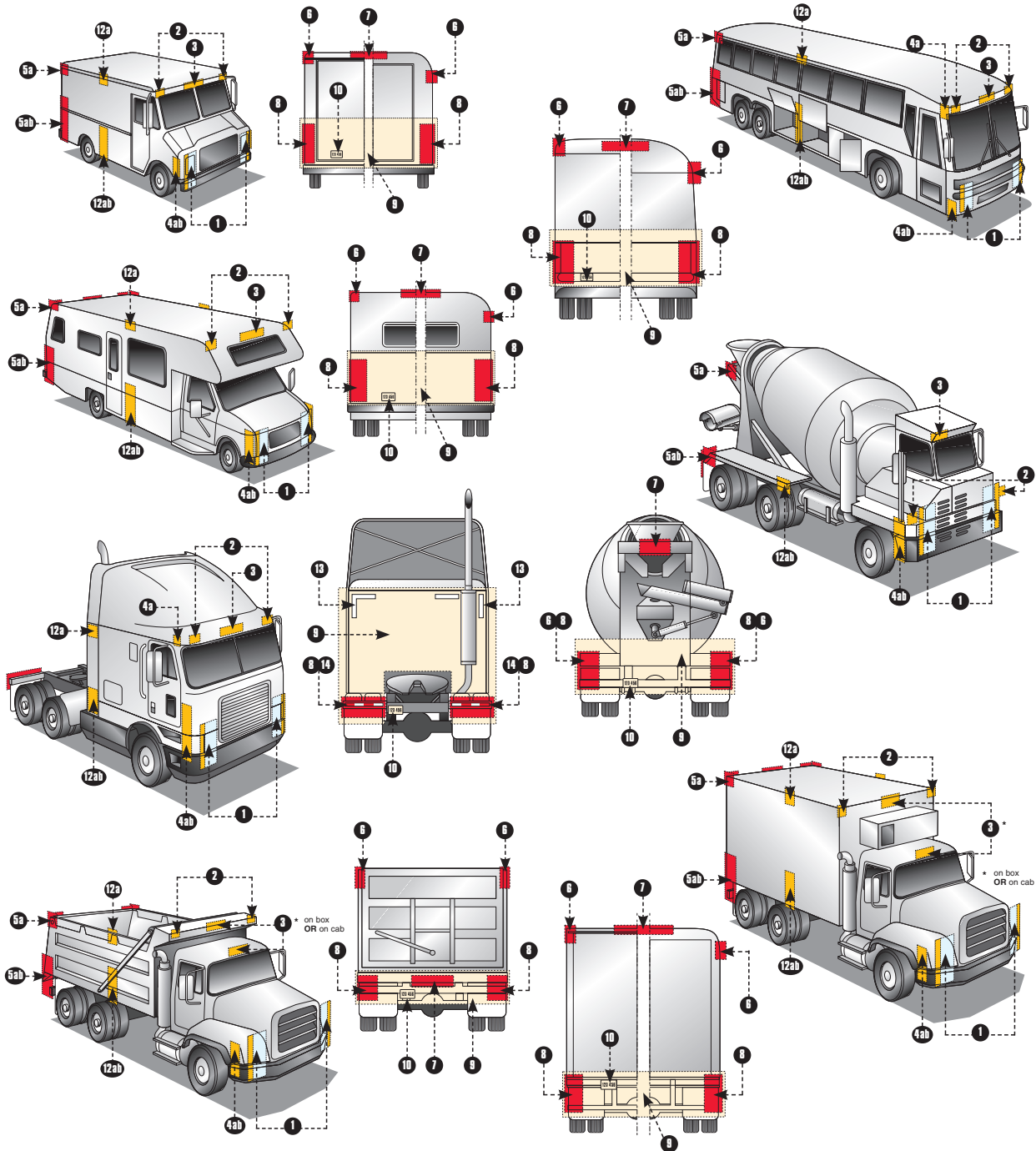

This table summarizes lighting equipment requirements contained in Federal/Canada Motor Vehicle Safety Standard 108. While Cequent Performance Products believes this to be an accurate summary of the latest printed information, the actual standard should be consulted for design or other such purposes. For complete compliance requirements consult Title 49 - Code of Federal Regulations-Section 571.108 (USA) or Section 108 of the Motor Vehicle Safety Regulations (Canada). State or Provincial regulations, where they may apply, have not been included.

For more information contact:
 Transport Canada, Motor Vehicle Safety Enforcement Branch
<http://www.tc.gc.ca>
 National Highway Traffic Safety Administration, Office of Safety Performance Standards
<http://www.nhtsa.dot.gov>

BASIC EQUIPMENT REQUIRED ON ALL TRUCKS, BUSES & MPVs

DESCRIPTION				MANDATORY REQUIREMENTS			
Area	Equipment	SAE Lens Coding	Functional Purpose	Quantity	Color	Location	Height mm(in.) from the ground
1	Headlamps - Lower Beam US requires "DOT" lettering on lens US&Canada - light source code required on lens	(H, HR)	Forward road illumination	Minimum 2	White	On the front - symmetrical as far apart as practicable If 4 lamp system - outboard or above upper beams	560-1370 (22-54)
	Headlamps - Upper Beam US requires "DOT" lettering on lens US&Canada - light source code required on lens	(H, HR)	Forward road illumination	Minimum 2	White	On the front - symmetrical If 4 lamp system - inboard or below lower beams	560-1370 (22-54)
	Parking Lamps Vehicles less than 2032mm wide	(P)	Indicate parked vehicle	Minimum 2	White or Yellow	On the front - symmetrical as far apart as practicable	380-1830 (15-72)
	Daytime Running Lamps (DRL) Canada - required / US - option US requires "DRL" lettering on lens if not headlamp	(Y2)	Indicate in use vehicle	Minimum 2	White or Yellow	On the front - symmetrical as far apart as practicable	380 (15) min. Max. depends on type of DRL
	Front Turn Signal/ Hazard Warning Lamps	(I)	Indicate direction of turn/ identify disabled vehicle	Minimum 2	Yellow	On the front- symmetrical as far apart as practicable	380-2110 (15-83)
2	Front Clearance Lamps Vehicles 2032mm wide or wider *photometrically certified at installation angle	(P2, PC* or P3, PC2*)	Show vehicle's width	Minimum 2	Yellow	At widest point - symmetrical on the front or near the front facing forward	As high as practicable
3	Front Identification Lamps (ID) Vehicles 2032mm wide or wider	(P2 or P3)	Indicate presence of a wide vehicle	Exactly 3	Yellow	On the front - center horizontally spaced 150 mm (6 in.) to 300 mm (12 in.) apart	As high as practicable or on top of the cab
4	a Front Side Marker Lamps *photometrically certified at installation angle	(P2, PC* P3, PC2*)	Front and rear side marker lamps / side reflex reflector indicate vehicle's presence and length	Minimum 2	Yellow	Each side at front as far forward as practicable	380 (15) minimum
	b Front Side Reflex Reflectors	(A)		Minimum 2	Yellow	Each side at front as far forward as practicable facing sideward	380-1530 (15-60)
5	a Rear Side Marker Lamps ** *photometrically certified at installation angle	(P2, PC* or P3, PC2*)	Rear side reflex reflector indicate vehicle's presence and length	Minimum 2	Red	Each side at rear as far back as practicable	380 (15) minimum
	b Rear Side Reflex Reflectors ** **not required on Truck Tractors	(A)		Minimum 2	Red	Each side at rear as far back as practicable facing sideward	380-1530 (15-60)
6	Rear Clearance Lamps Vehicles 2032mm wide or wider Not required on Truck Tractors *photometrically certified at installation angle	(P2, PC* or P3, PC2*)	Show vehicle's width MAY NOT be combined with tail lamps	Minimum 2	Red	At widest point - symmetrical on the rear or near the rear facing rearward	As high as practicable may be lower only if rear ID lamps are at the top
7	Rear Identification (ID) Lamps Vehicles 2032mm wide or wider Not required on Truck Tractors	(P2 or P3)	Indicate presence of a wide vehicle	Exactly 3	Red	On the rear - center horizontally spaced 150mm (6 in.) to 300mm (12 in.) apart facing rearward	At the top may be lower if door narrower than 25mm
8	Tail Lamps	(T)	Indicate vehicle's presence and width	Minimum 2	Red	On the rear - symmetrical as far apart as practicable	380-1830 (15-72)
	Stop Lamps	(S)	Indicate braking	Minimum 2	Red	On the rear - symmetrical as far apart as practicable	380-1830 (15-72)
	Rear Turn Signal/ Hazard Warning Lamps	(I)	Indicate direction of turn/ identify disabled vehicle	Minimum 2	Red or yellow	On the rear - symmetrical as far apart as practicable	380-2110 (15-83)
	Rear Reflex Reflectors	(A)	Show vehicle's presence and width	Minimum 2	Red	On the rear - symmetrical as far apart as practicable	380-1530 (15-60)
9	Backup Lamp	(R)	Illuminates ground behind the vehicle and alert road users	Minimum 1	White	Rear	No requirement
10	License Plate Lamp(s)	(L)	Illuminates license plate	Minimum 1	White	On the rear - above or at the sides of license plate	No requirement
11	Center High Mounted Stop Lamp Vehicles less than 2032mm wide and 4536kg	(U3)	Indicates braking	1	Red	On the rear - centerline of the vehicle	860 (34) minimum

**ADDITIONAL EQUIPMENT FOR SPECIFIC VEHICLES
VEHICLES 9.1m (30 ft.) LONG OR LONGER**

DESCRIPTION				MANDATORY REQUIREMENTS			
Area	Equipment	SAE Lens Coding	Functional Purpose	Quantity	Color	Location	Height mm(in.) from the ground
12	a Intermediate Side Marker Lamps	(P2 or P3)	Indicate presence of a long vehicle	Minimum 2	Yellow	Each side near center	380 (15) minimum
	b Intermediate Side Reflex Reflectors	(A)	Indicate presence of a long vehicle	Minimum 2	Yellow	Each side near center facing sideward	380-1530 (15-60)

Truck Tractors

DESCRIPTION		MANDATORY REQUIREMENTS					
Area	Conspicuity Treatment	DOT Coding	Quantity	Color	Location	Height	Options
13	Rear Upper Body Markings	DOT-C DOT-C2	Exactly 2 pairs of 300mm long strips	White	Rear upper corners of cab facing rearward	As high as practicable excluding fairings	
14	Rear Marking	DOT-C3 DOT-C4	Exactly 2 sections of min. 600mm each	Red/ White	Rear - facing rearward - on fenders, on mud flap brackets, or within 300mm below the top of mud flaps	As horizontal as practicable and not higher than 1525mm from the ground	If mud flaps not used - on the cab or frame mounted brackets

NOTE: The edge of red conspicuity tape shall not be closer than 75 mm to the edge of any amber lamp and the edge of white conspicuity tape shall not be closer than 75 mm to the edge of any lamp

STANDARD AG IMPLEMENT ENHANCED LIGHTING SCHEME

Under both the standard and enhanced lighting schemes, when traveling straight forward, the amber (outside) lights flash in unison with the tractor's amber lights on the high intensity at approximately 100 pulses per minute, and the low intensity of the red (inside) lights are on constantly.

With the standard wire harness in place, when a turn is being signaled, the amber light signaling the turn will increase flashing to approximately 120 pulses per minute with the amber light on the opposite side changing to a constant high intensity light. This mirrors the amber light on the tractor. Both red lights, however, remain on a constant low intensity.

To meet the enhanced lighting standard, introduce Electronic AG Light Enhanced Module to the implement's wire harness, and simply add red lights that have an active high intensity along with an additional RH and LH wire to these red lights. With this enhanced AG lighting system, during a turn the red light next to the amber turn side light will rapidly flash on the high intensity in unison with the amber light, and the red light on the opposite side will remain constant on the high intensity. This is a dramatic safety feature to better signal (to everyone) turns by tractors and implements.

AG LIGHTING WIRING DIAGRAM

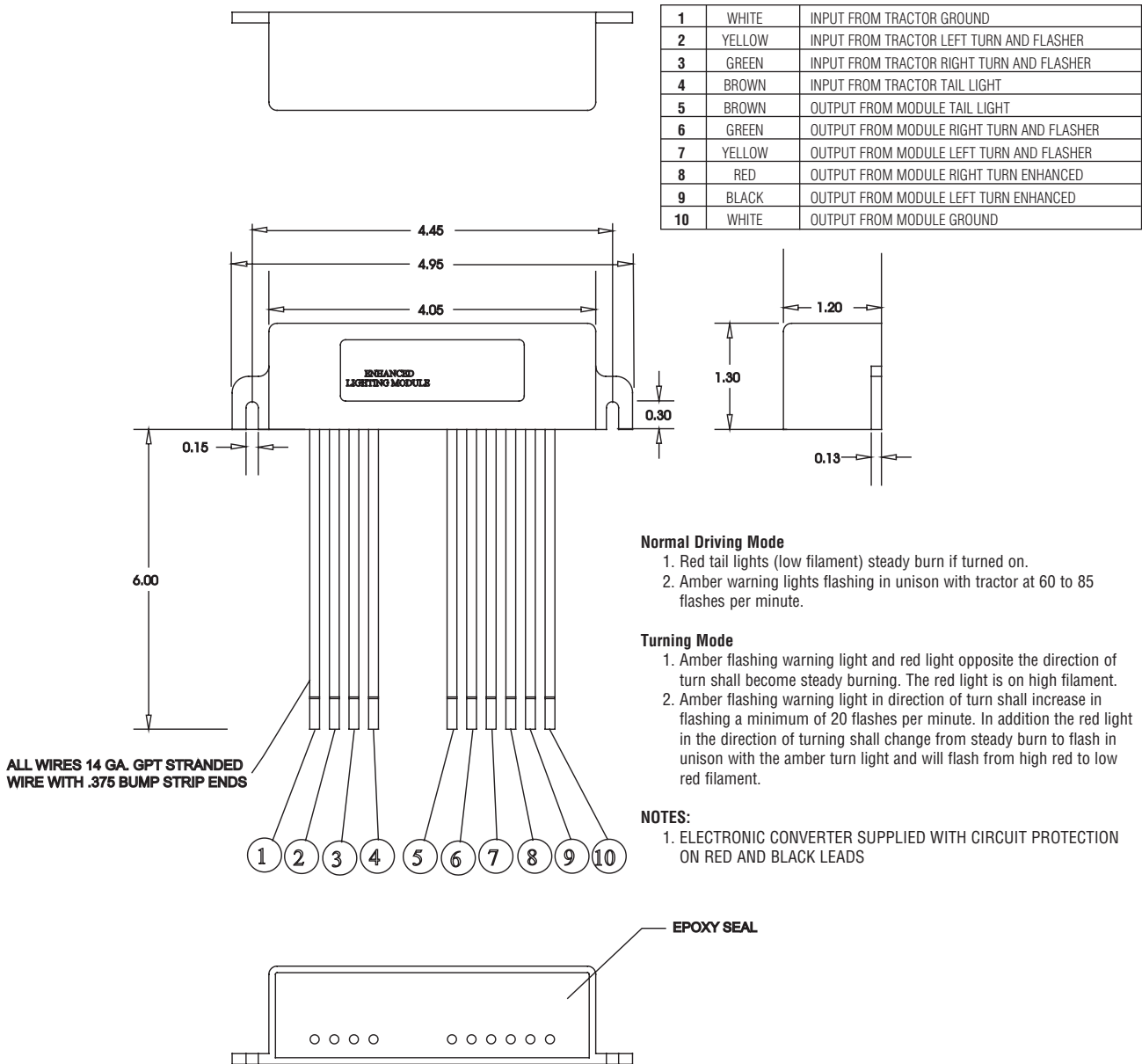

Rev. 02/10

AG LIGHTING WIRING DIAGRAM WITH BRAKE

1	WHITE	INPUT FROM TRACTOR GROUND
2	RED	INPUT FROM TRACTOR BRAKE SIGNAL
3	YELLOW	INPUT FROM TRACTOR LEFT TURN AND FLASHER
4	GREEN	INPUT FROM TRACTOR RIGHT TURN AND FLASHER
5	BROWN	INPUT FROM TRACTOR TAIL LIGHT
6	BROWN	OUTPUT FROM MODULE TAIL LIGHT
7	GREEN	OUTPUT FROM MODULE RIGHT TURN AND FLASHER
8	YELLOW	OUTPUT FROM MODULE LEFT TURN AND FLASHER
9	RED	OUTPUT FROM MODULE RIGHT TURN ENHANCED & BRAKE SIGNAL
10	BLACK	OUTPUT FROM MODULE LEFT TURN ENHANCED & BRAKE SIGNAL
11	WHITE	OUTPUT FROM MODULE GROUND

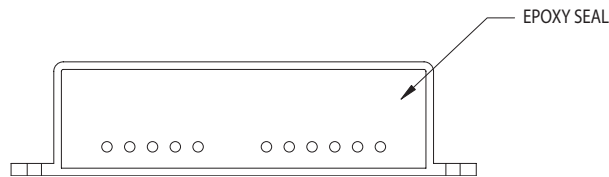
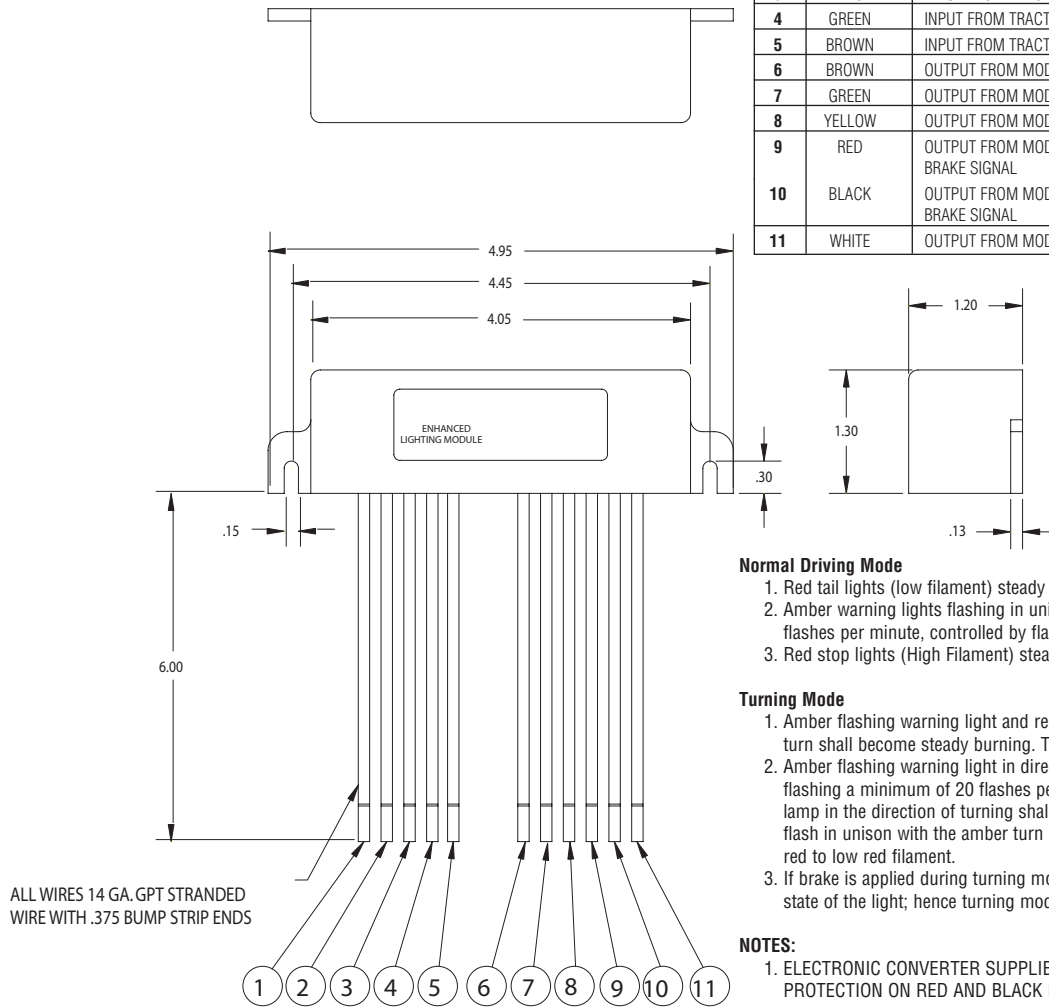

TECHNICAL INFORMATION IS CURRENT AS OF THE PRINTING OF THIS CATALOG. CONTACT TECHNICAL SERVICE FOR PERIODIC UPDATES.

AG LIGHTING



TECHNICAL INFORMATION IS CURRENT AS OF THE PRINTING OF THIS CATALOG. CONTACT TECHNICAL SERVICE FOR PERIODIC UPDATES.

AG LIGHTS

Meet lighting standards for agricultural field equipment and improve high-way operating safety easily and cost effectively with AG Lights by Cequent™. No other lighting package offers you the quality and dependability of AG Lights by Cequent. Designed specifically for the agricultural industry, AG Lights by Cequent withstand the most rigorous field and environmental conditions for long life and wear without repair. A variety of mounts enable easy and quick placement on all towable field equipment – harvesters, field cultivators, tillage equipment, forage boxes, and more.

SAFETY IS KEY

Meet ASAE lighting recommendations for agricultural equipment and improve safety, while operating on highways easily and cost effectively, with AG Lights by Cequent. No other lighting package offers you the quality, durability, and reliability of AG Lights by Cequent. Designed specifically for the agricultural industry, these Heavy-Duty AG Lights, when combined with Cequent's AG Wiring, withstand the most rigorous field and environmental conditions for long life and wear.

DURABLE, DEPENDABLE CONSTRUCTION OF HEAVY-DUTY AG LIGHTS

- High-impact, glass-filled thermoplastic housings deflect objects away from the lens area and prevent them from damaging or dislodging the lights assembly.
- Acrylic lenses.
- All fasteners provided are coated to resist rust.
- Bulb replacement, if ever needed, is simple – uses readily available standard automotive #1157 bulbs.

USER-FRIENDLY DESIGN

- AG Harnesses are designed with a full-length ground circuit, from tractor to AG Lamp, assuring reliable and continuous operation.
- Each light's wiring is routed through a center port area, helping facilitate a variety of light placement.
- AG Lights by Cequent are available with a variety of connector options.
- Mount lights vertically or horizontally. Choose from mounting screws, bolts, or heavy-duty magnets to meet your mounting needs.

- All lighting units are designed for easy customer repairs... right in the field. Pry out lenses with flat screwdriver for easy access to, and replacement of, the #1157 bulb.
- Five distinctly different light styles to meet your performance and styling requirements.

ELECTRONIC ENHANCED AG LIGHTING MODULE

Cequent, known for innovation and product reliability, presents an electronic module to deliver the ASAE recommended "enhanced turn signal lighting" with conventional AG lights and a standard wiring scheme. This unit may be hard-wired into the AG lighting harness or coupled-in by use of a variety of plug assemblies.

Use of Cequent's electronic enhanced AG lighting module helps to meet the new ASAE standard cost effectively. It eliminates the need for special wedge-based bulbs and non-standard wire schemes to deliver the enhanced turn signal lighting called for by this ASAE standard.

Refer to the Standard AG Implement Enhanced Lighting Guide.

MULTIPLE MOUNTING OPTIONS

A variety of mounts enable suitable placement on tractors and all towable field equipment – harvesters, cultivators, tillage equipment, fertilizers, forage boxes, and more. Heavy-Duty AG Lights by Cequent have a patented design incorporating multiple mounting options and lighting combinations. Dual AG Light models provide amber flashing and turn indicators plus red tail light functions. Amber or red single lights provide maximum mount flexibility (vertically or horizontally) to meet applicable lighting requirements. All AG Lights by Cequent, except the grommated series, are equipped with an exclusive molded weather-resistant low profile tri-plug. Custom plug configurations are also available.

Additionally, an optional brake light function is available for dual light or single red-lensed models. This optional function is also needed on lights used with enhanced turn light systems. The brake light option is recommended when implements are to be towed by non-farm vehicles or tractors with brakes (brake lights).

AG SAFETY LIGHTING SYSTEMS: Variety of Mounts and Uses

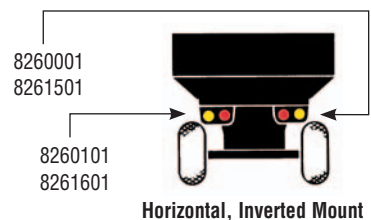
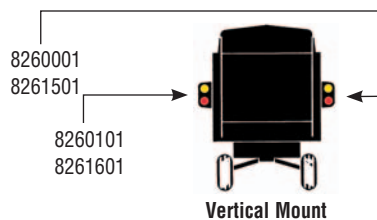
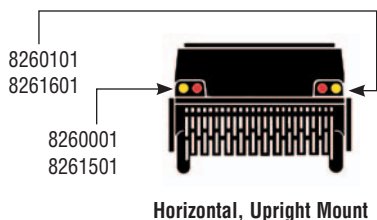

LOCKS

HITCH / TRAILER / COUPLER LOCKS

Hitch Locks

Trailer Locks

Coupler Locks

Keyed Alike Hitch and Coupler Locks

Trailer Wheel Lock

Silent Hitch Pin Locks

Gooseneck Lock

Fifth Wheel Rail / King Pin Lock

RETRACTABLE CABLE LOCK

ToyLok® and Accessories

ACCESSORY LOCKS

Cable Locks

Marine Outboard Motor Lock

Spare Tire Lock





580400

BULLDOG® LIFELONG® LOCKS DELIVER TRIPLE SECURITY

- Stronger Break Resistance
- Dual Self-locking Design
- High Security Square Key Design
- Includes Dust Cap



580401

580402

LIFELONG® HITCH LOCKS WITH 5/8" DIAMETER

Part No.	Description
580400	Chrome Bent Shank Lock for Class III & IV
580401	Chrome Dogbone Lock for Class III & IV
580402	Stainless Steel Dogbone Lock for Class III & IV

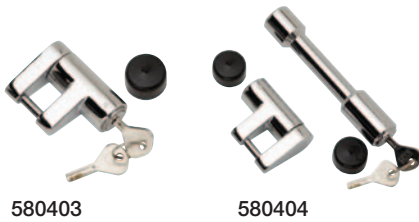

580403

580404

LIFELONG® TRAILER LOCK

Part No.	Description
580403	Chrome Coupler Lock

LIFELONG® COMBO LOCK

Part No.	Description
580404	Chrome Combo Lock Set, 5/8" Dogbone Receiver and Coupler, for Class III & IV



580405

BULLDOG® LOCKS

- Includes Dust Cap
- Easy Access Models Feature Side Key Entry, Sliding Dust Cap, Lock Housing Rotates 360°

HITCH LOCKS WITH 5/8" AND 1/2" DIAMETER

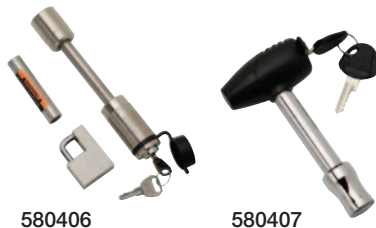

580406

580407

Part No.	Description
580405	Stainless Steel Dogbone Lock w/Sleeve for 1-1/4" & 2" Square Receivers
580406	Stainless Steel Combo Lock Set, 5/8" Dogbone Lock w/Sleeve for 1-1/4" & 2" Square Receivers and Coupler
580407	Easy Access Lock w/Sleeve for 1-1/4" & 2" Square Receivers



580408

580409

TRAILER LOCKS

Part No.	Description
580408	Stainless Steel Coupler Lock
580409	Easy Access Long Coupler Lock
580410	Easy Access Adjustable Coupler Lock
TK100 0100	Trailer Keeper® Lock - Heavy-duty, hardened steel construction. Adjustable to fit most trailer wheels up to 15". Includes brass lock and key set.



580410



TK100 0100



HITCH LOCKS WITH 5/8" AND 1/2" DIAMETER

Part No.	Description
63234*	Dogbone Lock w/Sleeve for 1-1/4", 2" & 2-1/2" Square Receivers
63248	Bent Pin Lock w/Extra Pin for 1-1/4" & 2" Square Receivers

* not compatible with 18K Titan® Receivers

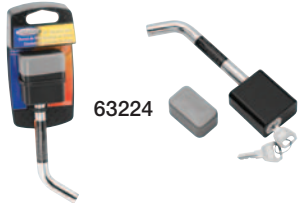

HITCH LOCKS WITH 1/2" DIAMETER

Part No.	Description
63224	Bent Pin Lock for 1-1/4" Square Receivers



HITCH LOCKS WITH 5/8" DIAMETER

Part No.	Description
63223	Bent Pin Lock for 2" & 2-1/2" Square Receivers
63252	Dogbone Lock for 2-1/2" Square Receivers, 3-1/2" Span, Class V
63253	Bent Pin Lock for 2-1/2" Square Receivers, 3-1/2" Span, Class V



TRAILER LOCKS

Part No.	Description
63225	Coupler Lock
63230	Brass Coupler Lock
63226	Universal Coupler Lock
63227	Coupler Lock for 2-5/16" Ball
63228	Coupler Lock for 2" Ball



COMBO LOCKS (HITCH, 5/8" & 1/2" DIA., AND TRAILER)

Part No.	Description
63249	Combo Lock Set, Bent Pin/Brass Coupler, for 1-1/4" & 2" Square Receivers
63250	Combo Lock Set, Dogbone Receiver/Coupler, for 1-1/4" & 2" Square Receivers



SILENT HITCH PIN AND LOCK SYSTEM

Eliminates noise associated with hitch accessories rattling against receiver tube. Unique design holds drawtube tight inside hitch receiver tube. For use with hollow shank ball mounts only.



Part No.	Description
63232	Class III Silent Hitch Pin, 5/8" design for 2" Square Receivers w/lock and wrench
63232-025	Class III Silent Hitch Pin, 5/8" design (25 pack)
63146	Silent Hitch Pin w/Handle and Clip, 5/8" for 2" Square Receivers
63145-025	Silent Hitch Pin w/Clip, 5/8" for 2" Square Receivers (25-pack)



New



63216KA 63219KA 63220KA

New



TP20A1534



63235

63236

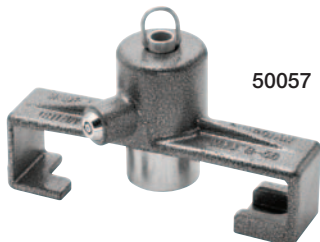

50057



50222



63251

KEYED ALIKE COUPLER AND HITCH LOCKS

- Avoid the complication of having to keep track of different keys for every lock
- Includes 2 keys
- Order in multiples of 3 / minimum order is 3 locks (TP20A1534 minimum is 21 locks)

Part No.	Description
63216KA	KEYED ALIKE 1/2" Receiver Lock for Class II Receiver Hitches
63217KA	KEYED ALIKE 5/8" Receiver Lock for Class III & IV Receiver Hitches
63218KA	KEYED ALIKE Class II 1/2" Receiver Lock and 1/2" Span Style Coupler Lock
63219KA	KEYED ALIKE Class III & IV 5/8" Receiver Lock and 1/2" Span Style Coupler Lock
63220KA	KEYED ALIKE 1/2" Span Style Coupler Lock
63221KA	KEYED ALIKE 2" Span Style Coupler Lock with 1/4" Pin
63222KA	KEYED ALIKE 2-1/2" Span Style Coupler Lock with 1/4" Pin
TP20A1534	KEYED ALIKE 2" Coupler Lock

TRAILER GUARDIAN LOCKS

- Helps prevent accidental decoupling
- Ability to lock and secure the trailer on the tow vehicle
- Two piece construction

Part No.	Description
63235	Single Arm Lock for 2-1/2" Wide Ball Mnt. Platform w/1" Ball Hole
63236	Dual Arm Lock for 2-1/2" Wide Ball Mnt. Platform w/1" Ball Hole
63237	Single Arm Lock for 3" Wide Ball Mnt. Platform w/1" Ball Hole
63238	Dual Arm Lock for 3" Wide Ball Mnt. Platform w/1" Ball Hole

Note: Cannot be used with some ball mounts in the rise position.

GOOSENECK LOCK

Part No.	Description
50057	Gooseneck Lock

FIFTH WHEEL LOCKS

Part No.	Description
KING PIN LOCKS	
50222	Fifth Wheel King Pin Lock
63251	Fifth Wheel King Pin Lock, Extruded T6 Tempered Aluminum Body
RAIL LOCK	
63254	Fifth Wheel Rail Lock, Push Button, Replaces One Locking Pin



63254

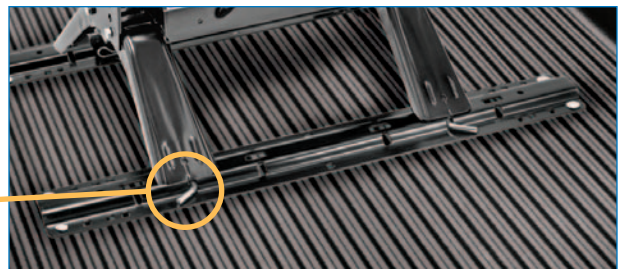



TL1020

LOCK IT UP.

ToyLok retractable cable system has a tamper resistant design that makes it difficult for scavengers to swipe your stuff!

CONVENIENCE

Retractable cable is easy to use and store, built-in clutch controls cable snap back PVC coated cable reduces abrasion and rub marks on your gear.

STRENGTH

Stainless Steel cable ends withstand heavy abuse. Cable rated to 8,000 lbs.

SECURITY

Finely braided cable makes it difficult for bolt cutters to work. 11 gauge welded steel housing. Breakaway security nut provides a theft resistant installation.



MOUNTING OPTIONS

TL005



RECEIVER MOUNT

Mount to any Class III hitch receiver.

TL002



FIFTH WHEEL KING PIN MOUNT

Attaches to fifth-wheel pin coupler.

TL006



STAKE POCKET MOUNT

Attaches to pick-up truck stake pockets.

TL010

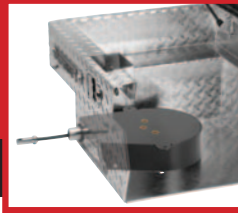

TOOLBOX MOUNT

Modifies toolbox to accept ToyLok retractable cable system.

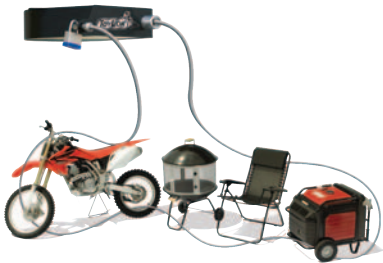

TL2021



Part No.	Description
TL1020	18' ToyLok Cable Lock (Mount Not Included)
TL002	ToyLok Adapter, Fifth Wheel King Pin Mount for #TL1020 only
TL005	ToyLok Adapter, 1-1/4" Sq. and 2" Sq. Receiver Mounting Kit for #TL1020, #TL2021
TL006	ToyLok Adapter, Stake Pocket Mount for #TL1020, #TL2021
TL007	ToyLok Adapter, Trailer Frame Mount for #TL1020, #TL2021
TL008	ToyLok Adapter, RV Bumper Mount for #TL1020, #TL2021
TL009	ToyLok Adapter, ATV & UTV Mount for #TL1020, #TL2021
TL010	ToyLok Adapter, Toolbox Mount for #TL1020, #TL2021
TL2021	ToyLok, 15' Cable Lock with padlock

TL005

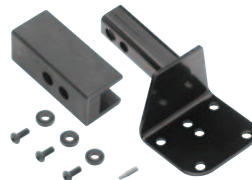

TL006

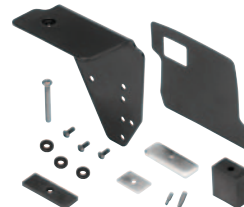

TL007

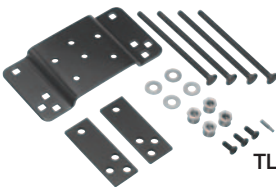

TL008

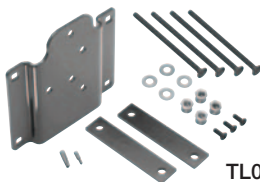

TL009

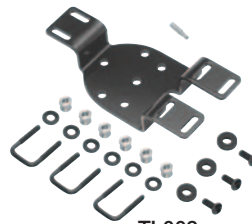

TL010





63233

CABLE LOCK

- Cable locks secure items to the vehicle
- Attractive point-of-purchase display packaging



Part No.	Description
CLK6 0700	6' Cable Lock w/ Key
CLK15 0100	15' Cable Lock w/ Key
63233	10' Dead Bolt Aircraft Cable with Lock, Case Lot 12



OML 0127

MARINE OUTBOARD MOTOR LOCK



- Heavy-duty barrel key lock mechanism for maximum security
- Foam filler insert reduces noise and vibration
- Mounts on most outboard motors

Part No.	Description
OML 0127	Outboard Motor Lock



STL 0603

SPARE TIRE LOCK



- Fits over wheel studs (up to 9/16" diameter) to help deter theft.
- Removable plug allows longer wheel studs to protrude through cap, and locking tab provides positive locking feature to help prevent lock from turning.

Part No.	Description
STL 0603	Spare Tire Lock

Push-To-Test Breakaway System

NEW!

Tekonsha® Push-To-Test Breakaway Kit with Integrated Multi-Stage Charger (50-85-313)
Pro Series™ Push-To-Test Breakaway Kit with Charger (50-85-315)

For proper performance of a breakaway system, battery must be maintained at a minimum of 80% capacity or greater.

This charge level is required to deliver enough current to the trailer brakes to be effective. The optimum charge level is 100%.

By setting our “Recharge” (Red) threshold at 80%, allows the operator ample opportunity to recharge the unit.

- For up to 3 axles
- Flat surface mounting
- Post mount bracket available (P/N 5085115)

Kits Include:

- 5 Amp/hr Battery
- Breakaway Switch w/7.5” lead wires
- Battery Box
- Charger



PUSH TO TEST (BATTERY)

TRAILER ACCESSORIES

BREAKAWAY SYSTEMS AND ACCESSORIES

Push to Test Breakaway Systems

Breakaway Systems

Breakaway Switches

Battery Chargers

Sealed Lead Acid Batteries

Battery Cases



ELECTRIC TRAILER BRAKE REPLACEMENT PARTS

Electric Trailer Brake Replacement Parts

Electric Trailer Brake Assemblies

Electric Trailer Brake Assemblies Self Adjusting

Magnets / Bearing Sets Reference Guide

Brake Part Reference Guide

Rim Clamps, Rim Clamp Bolts / Nuts

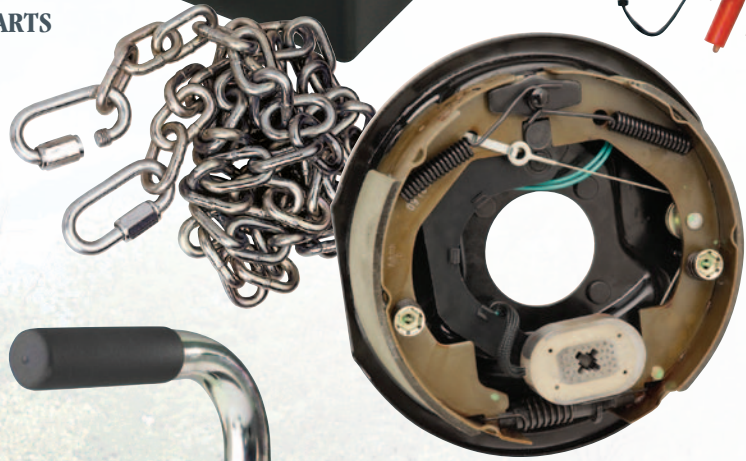

WHEEL PROTECTION

Wheel Bearing Kits

Bearing Protectors

Grease Caps

Plastic Fenders



TRAILER ACCESSORIES

HindSight™ Camera System

Trailer Alignment

Tire Chocks / EZ Move™ Trailer Handle

Safety Chains and Accessories

D-Rings / Tow Hooks

Spare Tire Carriers

Boat Guides / Marine Grade Carpeting

WaterWick™

Assist Bars / Door Bumpers

Access Doors

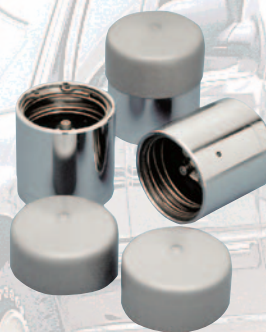



50-85-313

PUSH TO TEST BREAKAWAY SYSTEM

- Push to Test: LED's indicate fully charged, charging or recharge
- Multi-Stage Integrated Charger provides a fast recharge up to 12.8 volts. Once battery is fully charged, the automatic float mode is designed to provide a continuous charge without overcharging.
- Activates trailer brakes upon separation of trailer and tow vehicle
- For use on 1, 2 or 3 axle trailers equipped with electric brakes
- Weather/corrosion resistant, heavy-duty polymer case to protect battery and charger
- Quick and easy to install
- Breakaway Switch w/7.5" lead wires
- 5 Amp/hr Battery
- Battery Box, dimensions – 5" x 4.125" x 4"
- Flat Surface Mounting (Note: optional post mount bracket available)
- Weight – 4.95 lbs

Note: Make sure battery is fully charged prior to towing.



5085115
(Bracket Sold Separately)

Part No.	Description	Packaging
50-85-313	Push to Test Breakaway System with Multi-Stage Integrated Charger	Display Box - Tekonsha

Accessory Part

Part No.	Description	Packaging
5085115	Post Mount Bracket	Bulk



PUSH TO TEST BREAKAWAY SYSTEM

- Push to Test: Led's indicate fully charged, charging or (needs) recharge
- Built in battery charger charges battery when plugged into the tow vehicle
- Activates trailer brakes upon separation of trailer and tow vehicle
- For use on 1, 2, or 3 axle trailers equipped with electric brakes
- 1 year limited warranty

Note: Make sure battery is fully charged prior to towing.



50-85-315

Part No.	Description	Packaging
50-85-315	Push to Test Breakaway System with Charger	Display Box - Pro Series

Accessory Part

Part No.	Description	Packaging
5085115	Post Mount Bracket	Bulk



50-85-302



50-85-312



5085115
(Bracket Sold Separately)

BREAKAWAY SYSTEMS

- Activates trailer brakes upon separation of trailer and tow vehicle
- For use on 1, 2 or 3 axle trailers equipped with electric brakes
- Weather/corrosion resistant, heavy-duty polymer case to protect battery and charger
- **P/N 50-85-312 contains battery charger**
- Quick and easy to install
- Breakaway Switch w/7.5" lead wires
- 5 Amp/hr Battery
- Battery Box, dimensions – 5" x 4.125" x 4"
- Flat Surface Mounting (Note: optional post mount bracket available)
- Weight – 4.95 lbs

Note: Make sure battery is fully charged prior to towing.

Part No.	Description	Packaging
50-85-302	Breakaway System	Boxed
50-85-312	Breakaway System with Charger	Boxed

Accessory Parts

Part No.	Description	Packaging
5085115	Post Mount Bracket	Bulk



BREAKAWAY KIT W/ BUILT-IN BATTERY CHARGER

Complete system includes switch, 12 volt battery, battery box with built-in charger, mounting screws and installation instructions.



20048

- Provides neat, efficient battery connection
- Convenient test button verifies battery charge
- Built-in battery charger
- 1 or 2 axle capacity
- 5 amp/hr battery
- 1 year limited warranty

Note: Make sure battery is fully charged prior to towing.

Part No.	Description	Packaging
20048	Trailer Breakaway Kit	Display Box - Tow Ready

3 and 4 axle trailers require minimum 5 Amp-hr battery.

For optimal performance, replacement of breakaway electrical components is recommended every 3 to 5 years.



BREAKAWAY SYSTEMS

For use on 1, 2, 3 and 4 axle trailers equipped with electric brakes. These complete systems incorporate the highest quality components in trailer breakaway systems. Meet or exceed Department of Transportation (DOT) specifications regarding trailer breakaway and holding requirements. If a breakaway occurs between your tow vehicle and your trailer, the breakaway systems will automatically apply consistent braking power to your trailer brakes. Quick and easy to install, the systems comes with a weather/corrosion resistant, heavy-duty polymer case to protect the battery and charger.

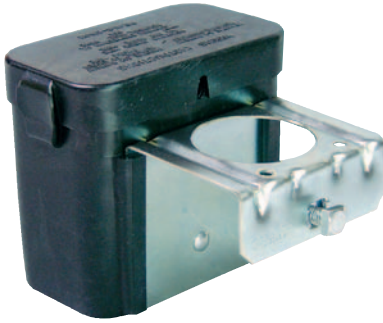

1026 / 1028 / 2026 / 2028 Systems & 2018 Case

Breakaway System - For use on 1 & 2 axle trailers with electric brakes.

Part No.	Description	Packaging
1026	Includes 2018 Polymer Battery Case w/A-Frame or Post Mounting Bracket; 2023 Rechargeable Sealed 12v 5 Amp-hr Lead Acid Battery & Terminals; 2005-P Breakaway Switch.	Display Box - Tekonsha



20005 / 20015 Systems & 2051 Case

50-85-200 / 50-85-201 Systems & 50-85-102 Case

Breakaway System - For use on 1, 2 & 3 axle trailers with electric brakes.

Part No.	Description	Packaging
50-85-200	Includes 50-85-102 Lockable All Polymer Battery Case w/Flat Surface Mounting; 2023 Rechargeable Sealed 12v 5 Amp-hr Lead Acid Battery & Terminals; 50-85-007 Breakaway Switch.	Bulk

Breakaway System - For use on 1, 2, 3 & 4 axle trailers with electric brakes.

Part No.	Description	Packaging
2026	Includes 2018 Polymer Battery Case w/A-Frame or Post Mounting Bracket; 2023 Rechargeable Sealed 12v 5 Amp-hr Lead Acid Battery & Terminals; 2010-P Breakaway Switch.	Display Box - Tekonsha
20005	Includes 2051 Lockable All Polymer Battery Case w/Flat Surface Mounting; 2023 Rechargeable Sealed 12v 5 Amp-hr Lead Acid Battery & Terminals; 2010-P Breakaway Switch.	Display Box - Tekonsha
20010	Includes 20000 Lockable Polymer Battery Case w/Weldable Flat Surface Mounting; 2023 Rechargeable Sealed 12v 5 Amp-hr Lead Acid Battery & Terminals; 2010-P Breakaway Switch.	Display Box - Tekonsha



20010 / 20020 Systems & 20000 Case

Breakaway System With Charger - For use on 1, & 2 axle trailers with electric brakes.

Part No.	Description	Packaging
1028	Includes 2018 Polymer Battery Case w/A-Frame or Post Mounting Bracket; 2023 Rechargeable Sealed 12v 5 Amp-hr Lead Acid Battery & Terminals; 2005-P Breakaway Switch; 1024 DC-to-DC Accelerated Battery Charging Device (ABCD).	Display Box - Tekonsha

Breakaway System With Charger - For use on 1, 2 & 3 axle trailers with electric brakes.

Part No.	Description	Packaging
50-85-201	Includes 50-85-102 Lockable All Polymer Battery Case w/Flat Surface Mounting; 2023 Rechargeable Sealed 12v 5 Amp-hr Lead Acid Battery & Terminals; 50-85-007 Breakaway Switch; 1024 DC-to-DC Accelerated Battery Charging Device (ABCD).	Bulk

Breakaway System With Multi-Stage Integrated Charger - For use on 1, 2, 3 & 4 axle trailers with electric brakes.

Part No.	Description	Packaging
2028	Includes 2018 Polymer Battery Case w/A-Frame or Post Mounting Bracket; 2023 Rechargeable Sealed 12v 5 Amp-hr Lead Acid Battery & Terminals; 2010-P Breakaway Switch; 2024-07 DC-to-DC Heavy Duty Quick/Maintenance (Multi Stage) Battery Charger.	Display Box - Tekonsha
20015	Includes 2051 Lockable All Polymer Battery Case w/Flat Surface Mounting; 2023 Rechargeable Sealed 12v 5 Amp-hr Lead Acid Battery & Terminals; 2010-P Breakaway Switch; 2024-07 DC-to-DC Heavy Duty Quick/Maintenance (Multi Stage) Battery Charger.	Display Box - Tekonsha
20020	Includes 20000 Lockable Polymer Battery Case w/Weldable Flat Surface Mounting; 2023 Rechargeable Sealed 12v 5 Amp-hr Lead Acid Battery & Terminals; 2010-P Breakaway Switch; 2024-07 DC-to-DC Heavy Duty Quick/Maintenance (Multi Stage) Battery Charger.	Display Box - Tekonsha



Battery Terminals Included in systems

3 and 4 axle trailers require minimum 5 Amp-hr battery.

For optimal performance, replacement of breakaway electrical components is recommended every 3 to 5 years.



50-85-007 Switch



2010 Switch



2005 Switch

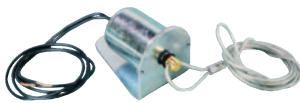

2009 Switch



2023 Battery

Most states require breakaway switch with separate power supply when towing a trailer.



2024-07 Charger



2025-09 Charger



1024/50-85-104 Charger

BREAKAWAY SWITCHES

Completely sealed breakaway switches to automatically set trailer brakes in case of accidental trailer breakaway. Required by law in some states. Emergency use only, not to be used to lock brakes when parked or stored. 2010, 50-85-007 and 2005 have reinforced nylon case, weldable metal tab, nylon pin assembly and are rust and corrosion free. 2009 has all metal parts and a brass pin assembly.

Part No.	Description	Packaging
50-85-007	Breakaway Switch w/ 48" wires w/Cable & Nylon Pin Assembly	Bulk
54-85-007	Breakaway Switch w/ 48" wires w/Cable & Nylon Pin Assembly	Bagged - Bargman
2010-B125	Breakaway Switch w/ 48" wires w/Cable & Nylon Pin Assembly	Bulk
2010-P	Breakaway Switch w/ 48" wires w/Cable & Nylon Pin Assembly	Clam - Tekonsha
2005-B120	Breakaway Switch w/ 48" wires w/Cable & Nylon Pin Assembly (for use with 1-3 axle trailers)	Bulk
2005-P	Breakaway Switch w/ 48" wires w/Cable & Nylon Pin Assembly (for use with 1-3 axle trailers)	Clam - Tekonsha
2009-B60	Breakaway Switch w/ 48" wires w/Cable & Brass Pin Assembly	Bulk
2009-P	Breakaway Switch w/ 48" wires w/Cable & Brass Pin Assembly	Clam - Tekonsha

Replacement Parts

Part No.	Description	Packaging
2010-A	48" Replacement Cable & Nylon Pin Assembly (for 2010 Switch)	Bulk
2010-A-P	48" Replacement Cable & Nylon Pin Assembly (for 2010 Switch)	Clam - Tekonsha
2005-A	48" Replacement Cable & Nylon Pin Assembly (for 2005 Switch)	Bulk
2009-A	48" Replacement Cable & Brass Pin Assembly (for 2009 Switch)	Bulk
2009-A-P	48" Replacement Cable & Brass Pin Assembly (for 2009 Switch)	Clam - Tekonsha

SEALED LEAD ACID BATTERY

12v, sealed lead acid battery for use with Breakaway Systems on single, tandem and tri-axle trailers equipped with electric brakes. Battery requires periodic recharging to maintain optimum performance.

Part No.	Description	Packaging
2023	5 Amp-hr Sealed Battery	Bulk
2023-X	5 Amp-hr Sealed Battery	Display Box - Tekonsha

BATTERY CHARGERS

For all 12v battery systems with a 4 Amp-hr minimum output. 2024-07 is designed to fit securely into the Breakaway Battery Cases. Temperature compensated design provides continuous recharge with automatic float mode feature to prevent overcharging. 1024/50-85-104 will return trailer breakaway system batteries to their maximum potential. Patent pending. 2025-09 features an automatic float mode to prevent overcharging. Ideal for seasonal storage and maintenance of recreational vehicles, motorcycles, snowmobiles, lawn tractors, and more.

Part No.	Description	Packaging
50-85-104	DC-to-DC Accelerated Battery Charging Device (ABCD)	Bulk
1024	DC-to-DC Accelerated Battery Charging Device (ABCD)	Clam - Tekonsha
2024-07	DC-to-DC Heavy Duty Multi Stage/Maintenance Charger	Bulk
2024-07-S	DC-to-DC Heavy Duty Multi Stage/Maintenance Charger	Clam - Tekonsha
2025-09	AC-to-DC Multi Stage Maintenance Charger	Clam - Tekonsha

BATTERY CASES

Rust-proof heavy duty polymer cases protect battery and charger from elements and corrosion. Featuring U-shaped clamp style fastener on #2018 to mount over most trailer tongues, #2051/5085102 is a lockable case, and #20000 features a galvanized metal mounting bracket with locking bar for secure battery protection.

Part No.	Description	Packaging
2018	Battery Case - One-Bolt Installation on Jackpost or A-Frame	Bulk
2051	Battery Case - Four-Bolt Installation on Flat Surface	Bulk
50-85-102	Battery Case - Four-Bolt Installation on Flat Surface	Bulk
20000	Battery Case - Two-Bolt or Weldable Installation on Flat Surface	Bulk



ALKO 10" x 2 1/4"

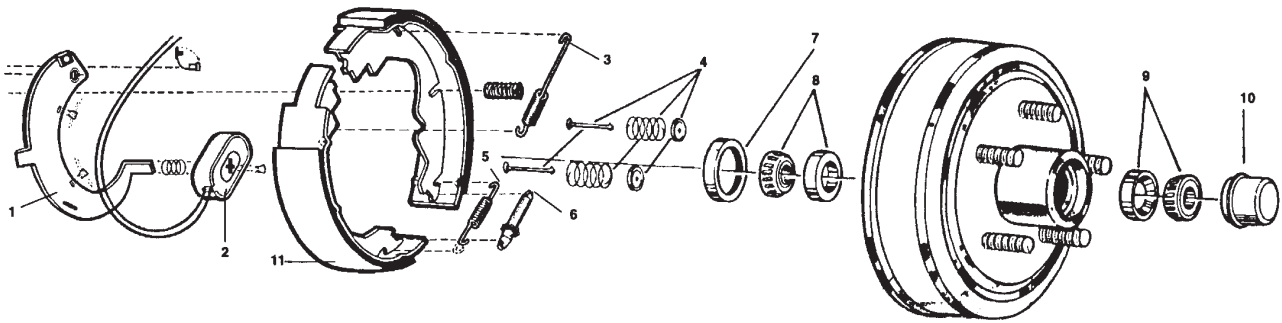

Tekonsha Part No.	Illustration No.	Description
Hardware		
6205	1	Actuating Lever - R.H.
6206	1	Actuating Lever - L.H.
6106	2	Magnet Kit
5304	3	Return Spring Set (Axle Set)
5353	4	Hold Down Kit (Axle Set)
5404	5,6	Adjusting Screw Kit (Spring & Screw Assembly)

Tekonsha Part No.	Illustration No.	Description
Grease Seal & Cap		
6604/5604	7	Seal (Axle Set)
5651	10	Grease Cap (Axle Set)
Bearing Sets		
5505	8	Bearing Set - Inner
5502	9	Bearing Set - Outer
Brake Shoes		
6004	11	Shoe and Lining Kit (Wheel Set)
Brake Assembly		
6709TEK		Complete Assembly - L.H.
6710		Complete Assembly - R.H.

ALKO 12" x 2"

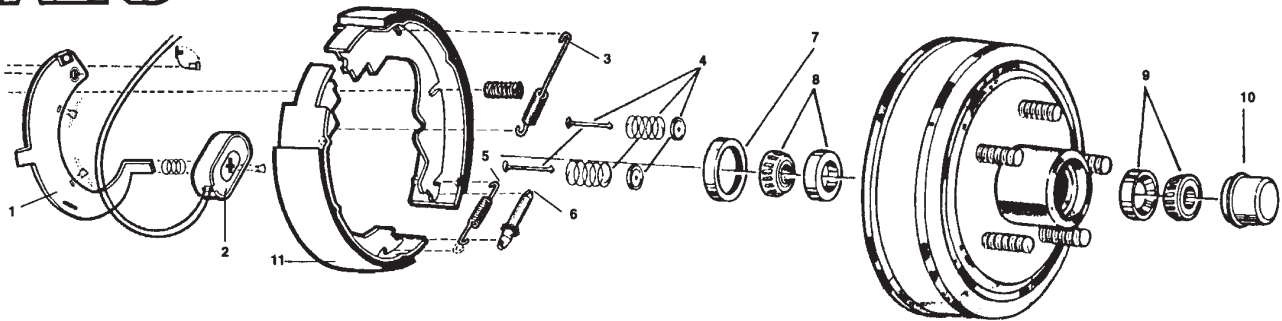

Tekonsha Part No.	Illustration No.	Description
Hardware		
6211	1	Actuating Lever - R.H.
6212	1	Actuating Lever - L.H.
6109	2	Magnet Kit 6K & 7K
5307	3	Return Spring Set (Axle Set)
5353	4	Hold Down Kit (Axle Set)
5404	5,6	Adjusting Screw Kit (Spring & Screw Assembly)

Tekonsha Part No.	Illustration No.	Description
Grease Seal & Cap		
6605/5605	7	Seal (Axle Set) (Replace in Pairs)
6658	10	Grease Cap (Axle Set) for 5508
5652	10	Grease Cap (Axle Set) for 5509
Bearing Sets		
5503	8	Bearing Set - Inner
5508	9	Bearing Set - Outer - 865 Large Bore
5509	9	Bearing Set - Outer - Small Bore
Brake Shoes		
6005	11	Shoe and Lining Kit (Wheel Set)
Brake Assembly		
6713		Complete Assembly - L.H.
6714		Complete Assembly - R.H.

Dexter 7" x 1 1/4"

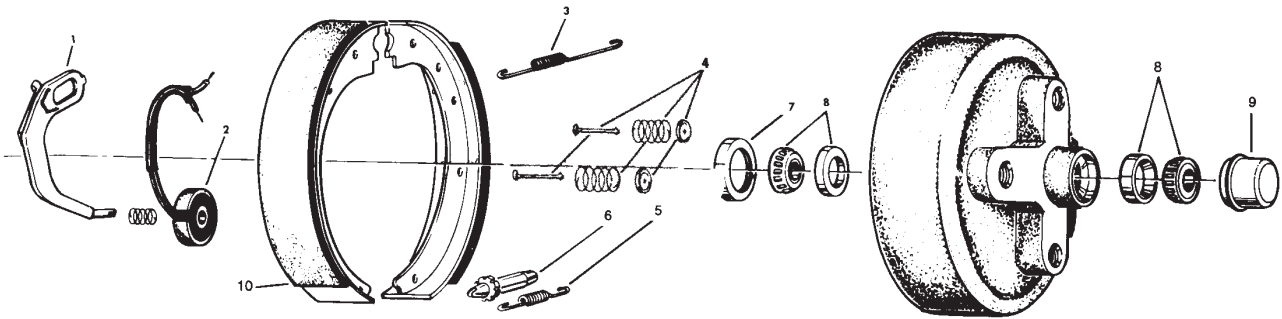

Tekonsha Part No.	Illustration No.	Description
Hardware		
5203 (N/A)	1	Actuating Lever - R.H.
5204 (N/A)	1	Actuating Lever - L.H.
5104 (N/A)**	2	Magnet Kit
5113***	2	Magnet Kit
Hardware (Axle Set)		
5320*	3	Return Spring
5320*	4	Hold Down Clips
5320*	5	Adjusting Screw Spring
5320*	6	Adjusting Screw Assembly

Tekonsha Part No.	Illustration No.	Description
Grease Seal & Cap		
5603	7	Seal - BTR (Axle Set)
5651	9	Grease Cap (Axle Set)
Bearing Sets		
5502	8	Bearing Set - Inner & Outer
Brake Shoes		
5002	10	Shoe and Lining Kit (Wheel Set)

*Contained in Hardware Kit (Axle Kit)
 **5104 Prior to 4-1990
 ***5113 After 4-1990
 (N/A) - No Longer Available

Dexter 10" x 1 1/2"

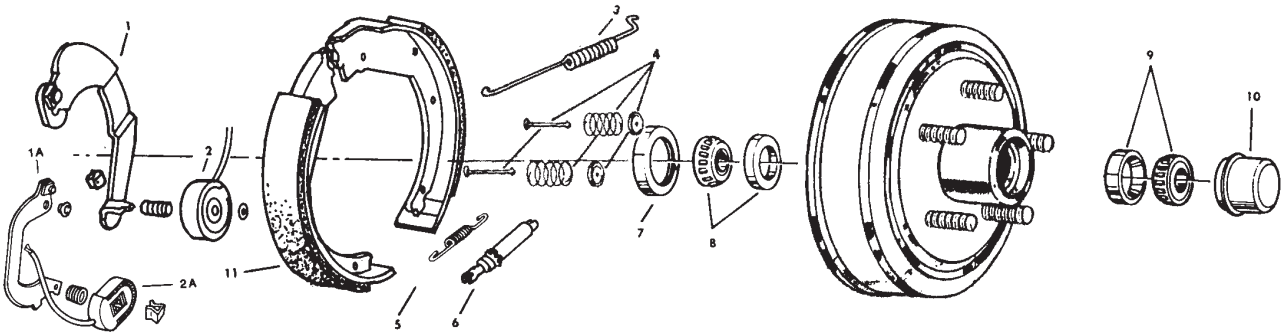

Tekonsha Part No.	Illustration No.	Description
Hardware		
5223 (N/A)*	1	Actuating Lever - R.H.
5231 (N/A)**	1A	Actuating Lever - R.H.
5224 (N/A)*	1	Actuating Lever - L.H.
5232 (N/A)**	1A	Actuating Lever - L.H.
5113*	2	Magnet Kit
5118**	2A	Magnet Kit
5306	3	Return Spring Set (Axle Set)
5356 (N/A)	4	Hold Down Kit (Axle Set)
5404	5,6	Adjusting Screw Kit (Spring & Screw Assembly)

Tekonsha Part No.	Illustration No.	Description
Grease Seal & Cap		
5607	7	Seal (Axle Set)
5651	10	Grease Cap (Axle Set)
Bearing Sets		
5507	8	Bearing Set - Inner
5502	9	Bearing Set - Outer
Brake Shoes		
5009	11	Shoe and Lining Kit (Wheel Set)

*Prior to Mid 1988
 **After Mid 1988
 (N/A) - No Longer Available



Dexter 10" x 2 1/4"

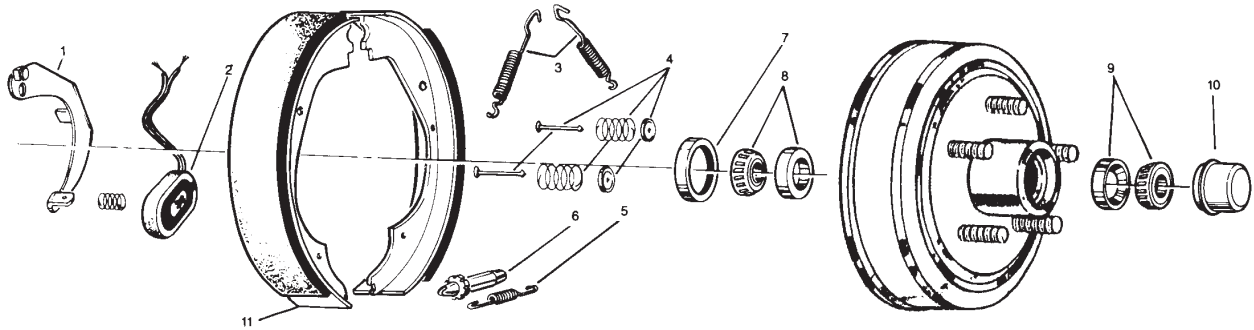

Tekonsha Part No.	Illustration No.	Description
Hardware		
5209	1	Actuating Lever - R.H.
5210	1	Actuating Lever - L.H.
5106	2	Magnet Kit
5305	3	Return Spring Set (Axle Set)
5353	4	Hold Down Kit (Axle Set)
5404	5,6	Adjusting Screw Kit (Spring & Screw Assembly)

Tekonsha Part No.	Illustration No.	Description
Grease Seal & Cap		
5604	7	Seal (Axle Set)
5651	10	Grease Cap (Axle Set)
Bearing Sets		
5506	8	Bearing Set - Inner (Prior to Dec. 1983)
5505	8	Bearing Set - Inner (After Dec. 1983)
5502	9	Bearing Set - Outer
Brake Shoes		
5003	11	Shoe and Lining Kit (Wheel Set)
Brake Assembly		
5707		Complete Assembly - L.H.
5708		Complete Assembly - R.H.

Dexter 12" x 2"

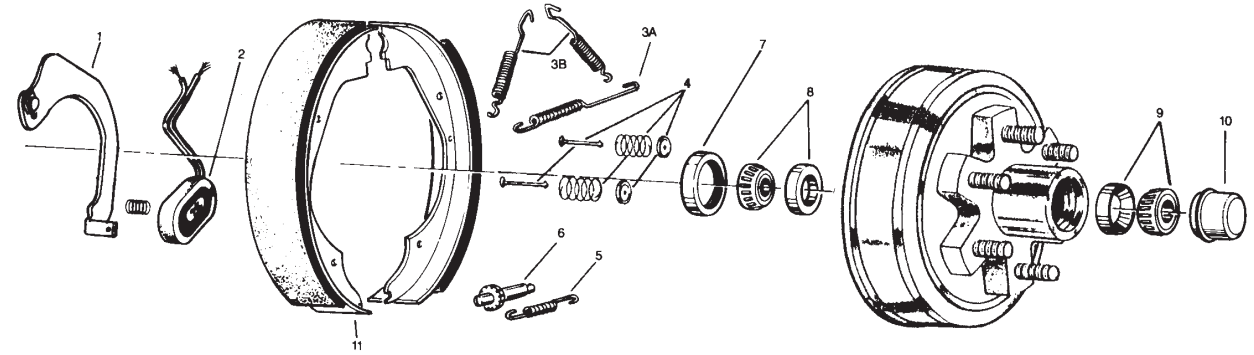

Tekonsha Part No.	Illustration No.	Description
Hardware		
5215	1	Actuating Lever - R.H.
5216	1	Actuating Lever - L.H.
5109	2	Magnet Kit
Return Spring Set (Axle Set)		
5307	3A	Single Retractor
5305	3B	Dual Retractor
5353*	4	Hold Down Kit (Axle Set)
5404	5,6	Adjusting Screw Kit (Spring & Screw Assembly)

Tekonsha Part No.	Illustration No.	Description
Grease Seal & Cap		
5606**	7	Seal (Axle Set)
5608***	7	Seal (Axle Set)
5652	10	Grease Cap (Axle Set)
Bearing Sets		
5503	8	Bearing Set - Inner
5507	9	Bearing Set - Outer
Brake Shoes		
5000-DX	11	Shoe and Lining Kit (Wheel Set)
Brake Assembly		
5711		Complete Assembly - L.H.
5712		Complete Assembly - R.H.

*Replacement Kit Uses Coil Springs

**Prior to 1997

***After 1997 (A Series Only)

TRAILER BRAKE REPLACEMENT PARTS



Dexter 12" x 2" 7K

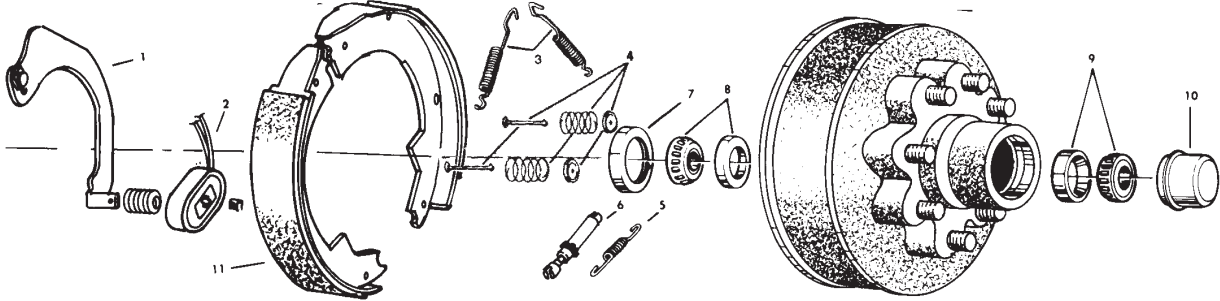

Tekonsha Part No.	Illustration No.	Description
Hardware		
5215	1	Actuating Lever - R.H.
5216	1	Actuating Lever - L.H.
5114	2	Magnet Kit
5305	3	Return Spring Set (Axle Set)
5353	4	Hold Down Kit (Axle Set)
5404	5,6	Adjusting Screw Kit (Spring & Screw Assembly)

*Prior to 1997

**After 1997 (A Series Only)

Tekonsha Part No.	Illustration No.	Description
Grease Seal & Cap		
5606*	7	Seal (Axle Set)
5608**	7	Seal (Axle Set)
5652	10	Grease Cap (Axle Set)
Bearing Sets		
5503	8	Bearing Set - Inner
5508	9	Bearing Set - Outer (865 HUB)
5509	9	Bearing Set - Outer (UTG Hub)
Brake Shoes		
5010	11	Shoe and Lining Kit (Wheel Set)

Hayes 10" x 1 5/8"

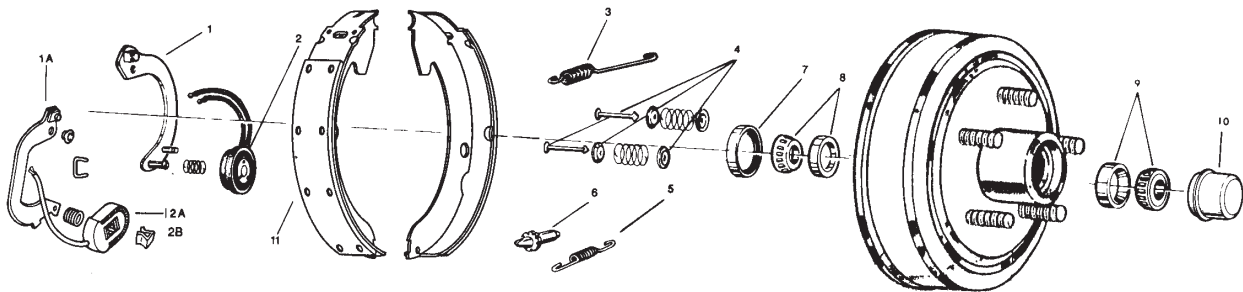

Tekonsha Part No.	Illustration No.	Description
Hardware		
5221 (N/A)*	1	Actuating Lever - R.H.
5233 (N/A)**	1A	Actuating Lever - R.H.
5222 (N/A)*	1	Actuating Lever - L.H.
5234 (N/A)**	1A	Actuating Lever - L.H.
5105*	2	Magnet Kit (4.5K Axles)
5106**	2A	Magnet Kit (6K & 7K Axles)
5101-HA***	2B	Magnet Kit - White Wire
5304	3	Return Spring Set (Axle Set)
5355(N/A)	4	Hold Down Kit (Axle Set)
5404	5,6	Adjusting Screw Kit (Spring & Screw Assembly)

Tekonsha Part No.	Illustration No.	Description
Grease Seal & Cap		
5604	7	Seal (Axle Set)
5651	10	Grease Cap (Axle Set)
Bearing Sets		
5507	8	Bearing Set - Inner
5502	9	Bearing Set - Outer
Brake Shoes		
5008 (N/A)	11	Shoe and Lining Kit (Wheel Set)

*Prior to Mid 1987

**After Mid 1987

***After Late 1994 (Replace in Pairs)

(N/A) - No Longer Available

TRAILER BRAKE REPLACEMENT PARTS



Hayes 10" x 2 1/4"

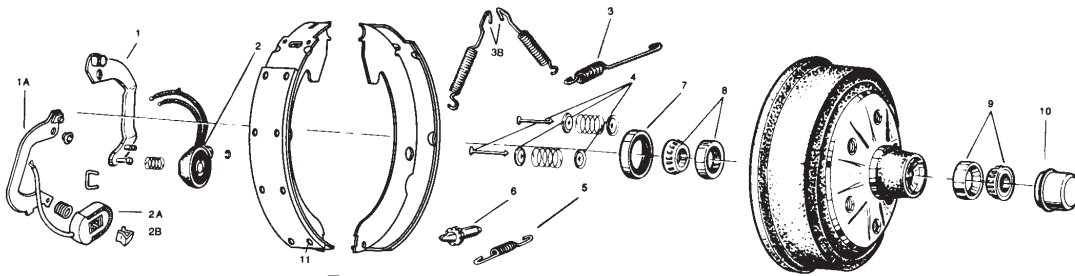

Tekonsha Part No.	Illustration No.	Description
Hardware		
5207 (N/A)*	1	Actuating Lever - R.H.
5205 (N/A)**	1A	Actuating Lever - R.H.
5208 (N/A)*	1	Actuating Lever - L.H.
5206 (N/A)**	1A	Actuating Lever - L.H.
5105*	2	Magnet Kit
5106**	2A	Magnet Kit
5101-HA	2B	Magnet Kit-White Wire After Late 1994 (Replace in Pairs)
Return Spring Set (Axle Set)		
5304	3A	Single Retractor
5305****	3B	Dual Retractor
5353	4	Hold Down Kit (Axle Set)
5404	5,6	Adjusting Screw Kit (Spring & Screw Assembly)

Tekonsha Part No.	Illustration No.	Description
Grease Seal & Cap		
5604	7	Seal (Axle Set)
5651	10	Grease Cap (Axle Set)
Bearing Sets		
5505***	8	Bearing Set - Inner
5502	9	Bearing Set - Outer
Brake Shoes		
6004	11	Shoe and Lining Kit (Wheel Set)
Brake Assembly		
5709-HA (N/A)		Complete Assembly - L.H. (Replace in Pairs)
5710-HA (N/A)		Complete Assembly - R.H. (Replace in Pairs)

*Prior to Mid 1987
 **After Mid 1987
 ***After 1972
 ****Prior to May 1977
 (N/A) - No Longer Available

Hayes 12" x 2"

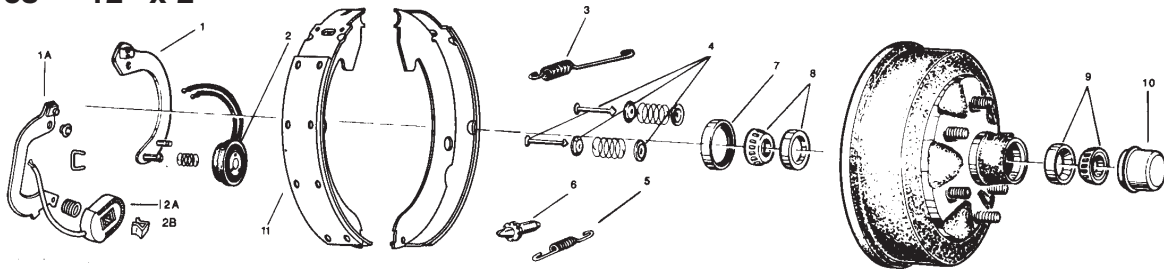

Tekonsha Part No.	Illustration No.	Description
Hardware		
5213 (N/A)*	1	Actuating Lever - R.H.
5211**	1A	Actuating Lever - R.H.
5214 (N/A)*	1	Actuating Lever - L.H.
5212**	1A	Actuating Lever - L.H.
5108 (N/A)*	2	Magnet Kit
5109**	2A	Magnet Kit
5101-HA	2B	Magnet Kit-White Wire After Late 1994 (Replace in Pairs)
5307	3	Return Spring Set (Axle Set)
5353	4	Hold Down Kit (Axle Set)
5404	5,6	Adjusting Screw Kit (Spring & Screw Assembly)

Tekonsha Part No.	Illustration No.	Description
Grease Seal & Cap		
5605	7	Seal (Axle Set)
5652	10	Grease Cap (Axle Set)
Bearing Sets		
5503	8	Bearing Set - Inner
5507	9	Bearing Set - Outer
Brake Shoes		
5000-HA (N/A)	11	Shoe and Lining Kit (Wheel Set)
Brake Assembly		
5713-HA		Complete Assembly - L.H. (Replace in Pairs)
5714-HA		Complete Assembly - R.H. (Replace in Pairs)

*Prior to Late 1987
 **After Late 1987
 (N/A) - No Longer Available

Hayes 12" x 2" Centerline

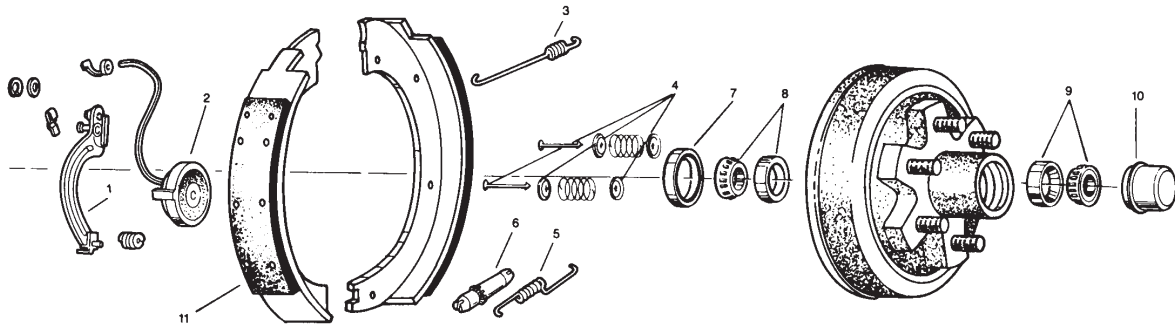

Tekonsha Part No.	Illustration No.	Description
Hardware		
5217 (N/A)*	1	Actuating Lever - R.H.
5218 (N/A)*	1	Actuating Lever - L.H.
5219 (N/A)**	1	Actuating Lever - R.H.
5220 (N/A)**	1	Actuating Lever - L.H.
5111 (N/A)	2	Magnet Kit (4.5K Axles)
5112 (N/A)	2	Magnet Kit (6K & 7K Axles)
5308 (N/A)	3	Return Spring Set (Axle Set)
5353	4	Hold Down Kit (Axle Set)
5404	5,6	Adjusting Screw Kit (Spring & Screw Assembly)

Tekonsha Part No.	Illustration No.	Description
Grease Seal & Cap		
5605	7	Seal (Axle Set)
5652	10	Grease Cap (Axle Set)
Bearing Sets		
5503	8	Bearing Set - Inner
5507	9	Bearing Set - Outer
Brake Shoes		
5006 (N/A)	11	Shoe and Lining Kit (Wheel Set) (4.5K and 6K Axles)
5007 (N/A)	11	Shoe and Lining Kit (Wheel Set) (7K Axles)

*Prior to Mid 1984
 **After Mid 1984-5220 Shown in illustration above.
 (N/A) - No Longer Available

Fayette 10" x 2 1/4"

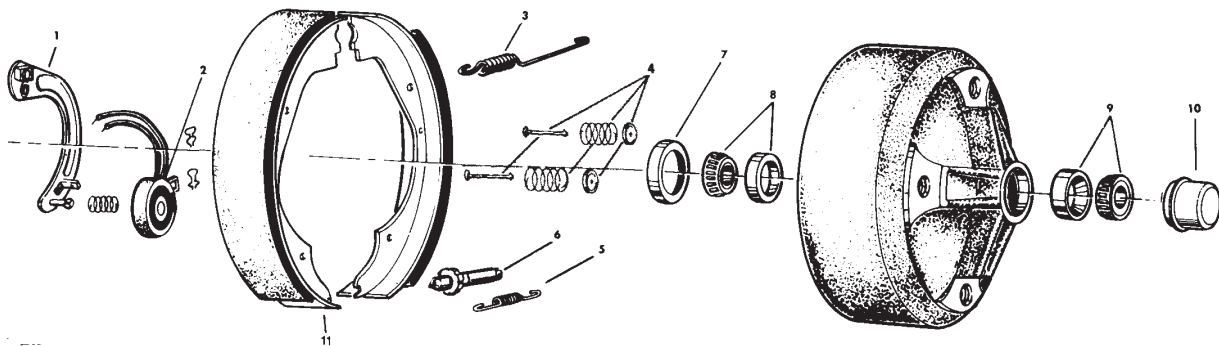

Tekonsha Part No.	Illustration No.	Description
Hardware		
(N/A)	1	Actuating Lever - R.H.
(N/A)	1	Actuating Lever - L.H.
5110 (N/A)	2	Magnet Kit
5304	3	Return Spring Set (Axle Set)
5353*	4	Hold Down Kit (Axle Set)
5404	5,6	Adjusting Screw Kit (Spring & Screw Assembly)

Tekonsha Part No.	Illustration No.	Description
Grease Seal & Cap		
5604	7	Seal (Axle Set)
5651	10	Grease Cap (Axle Set)
Bearing Sets		
5505***	8	Bearing Set - Inner
5502	9	Bearing Set - Outer
Brake Shoes		
5011(N/A)**	11	Shoe and Lining Kit (Wheel Set)

*Contained in Hardware Kit (Axle Kit)
 **-Bonded Shoes
 ***After 1972
 (N/A) - No Longer Available



Fayette 12" x 2"

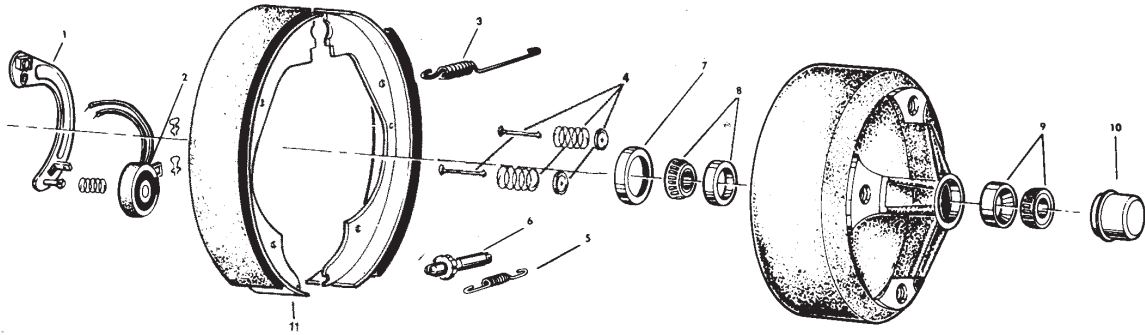

Tekonsha Part No.	Illustration No.	Description
Hardware		
(N/A)	1	Actuating Lever - R.H.
(N/A)	1	Actuating Lever - L.H.
5110 (N/A)	2	Magnet Kit
5307	3	Return Spring Set (Axle Set)
5353*	4	Hold Down Kit (Axle Set)
5404	5,6	Adjusting Screw Kit (Spring & Screw Assembly)

Tekonsha Part No.	Illustration No.	Description
Grease Seal & Cap		
5605	7	Seal (Axle Set)
5652	10	Grease Cap (Axle Set)
Bearing Sets		
5503	8	Bearing Set - Inner
5507	9	Bearing Set - Outer
Brake Shoes		
5000-DX**	11	Shoe and Lining Kit (Wheel Set)

*Replacement Kit Uses Coil Springs

**Bonded Shoes

(N/A) - No Longer Available

ELECTRIC TRAILER BRAKE ASSEMBLIES



- Units are assembled
- Assemblies include: Backing Plate, Shoe and Linings, Magnets, Actuating Lever, Adjusting Screw and Spring Hardware.

Part No.	Description
5707	10" x 2 1/4" L.H. Dexter Assembly
5708	10" x 2 1/4" R.H. Dexter Assembly
5709-HA (N/A)	10" x 2 1/4" L.H. Hayes Assembly (Replace in Pairs)
5710-HA (N/A)	10" x 2 1/4" R.H. Hayes Assembly (Replace in Pairs)
5711	12"x 2" L.H. Dexter Assembly
5712	12"x 2" R.H. Dexter Assembly
5713-HA	12"x 2" L.H. Hayes Assembly (Replace in Pairs)
5714-HA	12"x 2" R.H. Hayes Assembly (Replace in Pairs)
6709TEK	10" x 2 1/4" L.H. AL-KO Assembly
6710	10" x 2 1/4" R.H. AL-KO Assembly
6713	12" x 2" L.H. AL-KO Assembly
6714	12" x 2" R.H. AL-KO Assembly

(N/A) - No Longer Available

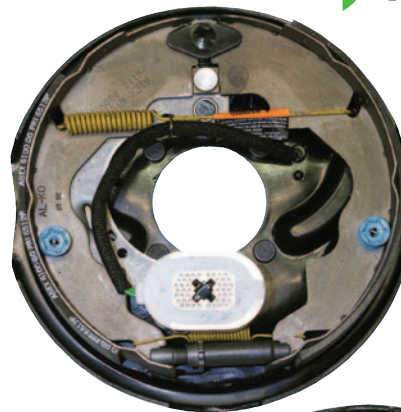



**SELF-ADJUSTING
ELECTRIC TRAILER BRAKE ASSEMBLIES**

- Replaces Dexter Electric Trailer Brake Assemblies
- Self Adjusting
- Units are assembled
- Replace in pairs
- Assemblies include: Backing Plate, Shoe and Linings, Magnets, Actuating Lever and Spring Hardware.



Part No.	Description
54801-005	10 x 2 1/4 Right Hand Brake Assembly - Self-Adjusting
54801-006	10 x 2 1/4 Left Hand Brake Assembly - Self-Adjusting
54801-007	12 x 2 Right Hand Brake Assembly - Self-Adjusting
54801-008	12 x 2 Left Hand Brake Assembly - Self-Adjusting



ELECTRIC TRAILER BRAKE ASSEMBLIES

- Replaces Dexter Electric Trailer Brake Assemblies
- Units are assembled
- Assemblies include: Backing Plate, Shoe and Linings, Magnets, Actuating Lever, Adjusting Screw and Spring Hardware.

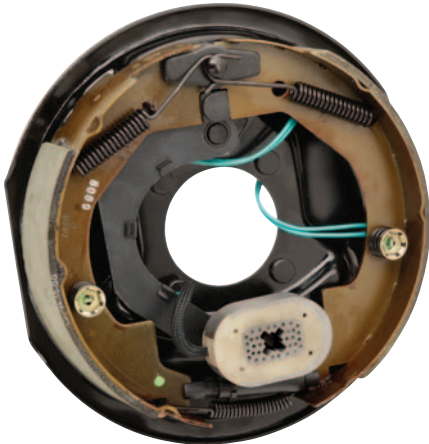

Part No.	Description
54801-001	10 x 2 1/4 Right Hand Brake Assembly
54801-002	10 x 2 1/4 Left Hand Brake Assembly
54801-003	12 x 2 Right Hand Brake Assembly
54801-004	12 x 2 Left Hand Brake Assembly



BRAKE ASSEMBLY MOUNTING BOLTS

Part No.	Description
5720	3/8" Brake Assembly Mounting Bolt (Used on 5 bolt mounting patterns)
5721	7/16" Brake Assembly Mounting Bolt (Used on 4 bolt mounting patterns)



5101-HA – White Wires

Length 3 1/8
 Width 2
 Thickness 15/16
 Fits or Replaces
 Hayes 10 x 1 5/8
 10 x 2 1/4
 12 x 2



(All - Replaces in pairs)
 (All - After Late 1994)

5104 – Yellow Wires (N/A)

(Prior to April 1990)

Length 2 1/32
 Width 1 31/32
 Thickness 3/4
 Fits or Replaces
 Dexter 7 x 1 1/4



(Prior to April 1990)
 Trailer Pac 120
 Tow Craft 1103-100-016

5105 – Red Wires

Length 3 1/4
 Width 2 3/8
 Thickness 7/8
 Fits or Replaces
 Hayes 10 x 2 1/4



(Prior to Mid 1987)
 Hayes 10 x 1 5/8
 (Prior to Mid 1987)
 Trailer Pac 100
 Tow Craft 1103-100-001

5106 – Green Wires

Length 3 1/8
 Width 2
 Thickness 15/16
 Fits or Replaces



Dexter 10 x 2 1/4
 Hayes 10 x 2 1/4
 (After Mid 1987)
 Hayes 10 x 1 5/8
 (After Mid 1987)

Trailer Pac 102
 Tow Craft 1103-100-017

5107 – White Wires (N/A)

Length 2 5/8
 Width 2 5/8
 Thickness 15/16
 Fits or Replaces



Foreman 12 x 2
 Trailer Pac 113
 Tow Craft 1103-100-010

5108 – Red Wires (N/A)

Length 3 9/16
 Width 2 11/16
 Thickness 7/8



Fits or Replaces
 Hayes 12 x 2
 (Prior to late 1987)
 Trailer Pac 101
 Tow Craft 1103-100-006

5109 – White Wires

Length 3 1/8
 Width 2
 Thickness 15/16



Fits or Replaces
 Dexter 12 x 2
 Hayes 12 x 2
 (After Late 1987)
 Trailer Pac 103
 Tow Craft 1103-100-018

5110 – White Wires (N/A)

Length 3 3/8
 Width 2 7/16
 Thickness 15/16



Fits or Replaces
 Fayette 10 x 2 1/4
 Fayette 12 x 2
 Trailer Pac 108
 109
 Tow Craft 1103-100-005
 1103-100-021

5111 – Red Orange Wires (N/A)

Length 3 11/16
 Width 2 1/16
 Thickness 1



Fits or Replaces
 Hayes 12 x 2 - 4.5 K
 Axles
 (Centerline)
 Trailer Pac 124
 Tow Craft 1103-100-023

5112 – Red Wires (N/A)

Length 3 11/16
 Width 3 1/16
 Thickness 1



Fits or Replaces
 Hayes 12 x 2 - 6K
 & 7K Axles
 (Centerline)
 Trailer Pac 125
 Tow Craft 1103-100-022

5113 – White Wires

Length 2 1/16
 Width 1 15/16
 Thickness 3/4



Fits or Replaces
 Dexter 10 x 1 1/2
 (Prior to Mid 1988)
 Dexter 7 x 1 1/4
 (After April 1990)

5114 – Black Wires

Length 3 1/8
 Width 2
 Thickness 15/16



Fits or Replaces
 Dexter 12 x 2 - 7K Axles

5118 – Yellow Wires

Length 3 1/8
 Width 2
 Thickness 15/16



Fits or Replaces
 Dexter 10 x 1 1/2
 (After Mid 1988)

6106 – Light Green Wires

Length 3 1/8
 Width 2
 Thickness 15/16

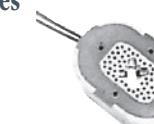

Fits or Replaces
 AL-KO Kober 10 x 2 1/4

6109 – White Wires

Length 3 1/8
 Width 2
 Thickness 15/16



Fits or Replaces
 AL-KO Kober 12 x 2 6K & 7K



Bearing Sets

Cup / Cone	Part No.
14276-14125A	5508
15245-15123	5509
25520-25580	5503
L44610-L44643	5501(N/A)
L44610-L44649	5502
LM48510-	5506
LM48548	
LM67010-	5507
LM67048	
L68111-L68149	5505

(N/A) - No Longer Available



Brake Assembly

Part No.	Description	Packaging
5707	10 x 2 1/4 Dexter (L.H.)	Boxed
5708	10 x 2 1/4 Dexter (R.H.)	Boxed
*5709-HA (N/A)	10 x 2 1/4 Hayes (L.H.)	
*5710-HA (N/A)	10 x 2 1/4 Hayes (R.H.)	
5711	12 x 2 Dexter (L.H.)	Boxed
5712	12 x 2 Dexter (R.H.)	Boxed
*5713-HA	12 x 2 Hayes (L.H.)	Boxed
*5714-HA	12 x 2 Hayes (R.H.)	Boxed
6709TEK	10 x 2 1/4 AL-KO (L.H.)	Boxed
6710	10 x 2 1/4 AL-KO (R.H.)	Boxed
6713	12 x 2 AL-KO (L.H.)	Boxed
6714	12 x 2 AL-KO (R.H.)	Boxed

Brake Assembly Mounting Bolts

Part No.	Description	Packaging
5720	3/8" 5 Bolt Mounting Pattern	Clam Shell
5721	7/16" 4 Bolt Mounting Pattern	Clam Shell

Magnet Kit

Part No.	Description	Packaging
*5101-HA	10 x 1 5/8 Hayes (After late 1994) 10 x 2 1/4 Hayes (After late 1994) 10 x 2 1/4 Hayes (After late 1994)	Boxed
5104 (N/A)	7 x 1 1/4 Dexter (Prior to 4-1990)	
5105	10 x 2 1/4 Hayes (Prior to Mid 1987) 10 x 1 5/8 Hayes (4.5K Axles) (Prior to Mid 1987)	Boxed
5106	10 x 2 1/4 Dexter 10 x 2 1/4 Hayes (After Mid 1987) 10 x 1 5/8 Hayes (6K&7K Axles) (After Mid 1987)	Boxed
5107 (N/A)	12 x 2 Foreman	
5108 (N/A)	12 x 2 Hayes (Prior to Late 1987)	
5109	12 x 2 Dexter 12 x 2 Hayes (After Late 1987)	Boxed
5110 (N/A)	10 x 2 1/4 Fayette 12 x 2 Fayette	
5111 (N/A)	12 x 2 Hayes Centerline (4.5K Axles)	
5112 (N/A)	12 x 2 Hayes Centerline (6K and 7K Axles)	
5113	10 x 1 1/2 Dexter (Prior to Mid 1988) 7 x 1 1/4 Dexter (After April 1990)	Boxed
5114	12 x 2 Dexter 7K	Boxed
5118	10 x 1 1/2 Dexter (After Mid 1988)	Boxed
6106	10 x 2 1/4 AL-KO	Boxed
6109	12 x 2 AL-KO 6K & 7K	Boxed

Magnet Retaining Ring (Not Pictured)

Part No.	Description	Packaging
5120TEK	10 x 1 5/8 Hayes 10 x 2 1/4 Hayes (Old Style) 12 x 2 Hayes (Old Style)	Clam Shell

Magnet Retaining Clip (Not Pictured)

Part No.	Description	Packaging
5121TEK	10 x 2 1/4 Dexter 12 x 2 Dexter 12 x 2 Dexter 7K 10 x 2 1/4 Hayes (New Style) 12 x 2 Hayes (New Style)	Clam Shell

Wire Clip (Not Pictured)

Part No.	Description	Packaging
5122	10 x 1 1/2 Dexter 10 x 2 1/4 Dexter 12 x 2 Dexter	Clam Shell

Actuating Lever

Part No.	Description	Packaging
5203 (N/A)	7 x 1 1/4 Dexter (R.H.)	
5204 (N/A)	7 x 1 1/4 Dexter (L.H.)	
5205 (N/A)	10 x 2 1/4 Hayes (R.H.) (After Mid 1987)	
5206 (N/A)	10 x 2 1/4 Hayes (L.H.) (After Mid 1987)	
5207 (N/A)	10 x 2 1/4 Hayes (R.H.) (Prior to Mid 1987)	
5208 (N/A)	10 x 2 1/4 Hayes (L.H.) (Prior to Mid 1987)	
5209	10 x 2 1/4 Dexter (R.H.)	Boxed
5210	10 x 2 1/4 Dexter (L.H.)	Boxed
5211	12 x 2 Hayes (R.H.) (After Late 1987)	Boxed
5212	12 x 2 Hayes (L.H.) (After Late 1987)	Boxed
5213 (N/A)	12 x 2 Hayes (R.H.) (Prior to Late 1987)	
5214 (N/A)	12 x 2 Hayes (L.H.) (Prior to Late 1987)	
5215	12 x 2 Dexter (R.H.) & 12 x 2 Dexter 7K (R.H.)	Boxed
5216	12 x 2 Dexter (L.H.) & 12 x 2 Dexter 7K (L.H.)	Boxed
5217 (N/A)	12 x 2 Hayes Centerline (R.H.) (Prior to Mid 1984)	
5218 (N/A)	12 x 2 Hayes Centerline (L.H.) (Prior to Mid 1984)	
5219 (N/A)	12 x 2 Hayes Centerline (R.H.) (After Mid 1984)	
5220 (N/A)	12 x 2 Hayes Centerline (L.H.) (After Mid 1984)	
5221 (N/A)	10 x 1 5/8 Hayes (R.H.) (Prior to Mid 1987)	
5222 (N/A)	10 x 1 5/8 Hayes (L.H.) (Prior to Mid 1987)	
5223 (N/A)	10 x 1 1/2 Dexter (R.H.) (Prior to Mid 1988)	
5224 (N/A)	10 x 1 1/2 Dexter (L.H.) (Prior to Mid 1988)	
5231 (N/A)	10 x 1 1/2 Dexter (R.H.) (After Mid 1988)	
5232 (N/A)	10 x 1 1/2 Dexter (L.H.) (After Mid 1988)	
5233 (N/A)	10 x 1 5/8 Hayes (R.H.) (After Mid 1987)	
5234 (N/A)	10 x 1 5/8 Hayes (L.H.) (After Mid 1987)	
6205	10 x 2 1/4 AL-KO (R.H.)	Boxed
6206	10 x 2 1/4 AL-KO (L.H.)	Boxed
6211	12 x 2 AL-KO (R.H.)	Boxed
6212	12 x 2 AL-KO (L.H.)	Boxed

(N/A) – No Longer Available

* (Replace in pairs)



Grease Cap (Axle Set)

Part No.	Description	Packaging
5651	7 x 1 1/4 Dexter 10 x 2 1/4 AL-KO 10 x 1 5/8 Hayes 10 x 1 1/2 Dexter 10 x 2 1/4 Hayes 10 x 2 1/4 Dexter 10 x 2 1/4 Fayette 10 x 2 1/4 Foreman	Clam Shell
5652	12 x 2 AL-KO (Small Bore) 12 x 2 Hayes & 12 x 2 Hayes Centerline 12 x 2 Dexter & 12 x 2 Dexter 7K 12 x 2 Fayette 12 x 2 Foreman	Clam Shell
6658	12 x 2 AL-KO (Large Bore)	Clam Shell
5602	7 1/4 x 1 1/4 Hayes	Clam Shell
5603	7 x 1 1/4 Dexter (BTR)	Clam Shell
5604	10 x 1 5/8 Hayes 10 x 2 1/4 AL-KO 10 x 2 1/4 Hayes 10 x 2 1/4 Dexter 10 x 2 1/4 Fayette	Clam Shell
5605	12 x 2 Hayes & 12 x 2 Hayes Centerline 12 x 2 Fayette 12 x 2 AL-KO*	Clam Shell
5606	12 x 2 Dexter (Prior 1997) & 12 x 2 Dexter 7K (Prior 1997)	Clam Shell
5607	10 x 1 1/2 Dexter	Clam Shell
5608	12 x 2 Dexter (After 1997 - A Series Only) & 12 x 2 Dexter 7K (After 1997 - A Series Only)	Clam Shell
6604/5604	10 x 2 1/4 AL-KO	Clam Shell
6605/5605	12 x 2 AL-KO*	Clam Shell

Shoe and Lining Kits (Wheel Set)

Part No.	Description	Packaging
5000-DX	12 x 2 Dexter 12 x 2 Fayette (Bonded Shoes) 12 x 2 Aimco 12 x 2 Foreman	Boxed
5000-HA (N/A)	12 x 2 Hayes	
5002	7 x 1 1/4 Dexter	Boxed
5003	10 x 2 1/4 Dexter	Boxed
5004 (N/A)	Use 6004	
5006 (N/A)	12 x 2 Hayes Centerline 4.5K and 6K	
5007 (N/A)	12 x 2 Hayes Centerline 7K	
5008 (N/A)	10 x 1 5/8 Hayes	
5009	10 x 1 1/2 Dexter	Boxed
5010	12 x 2 Dexter 7K	Boxed
5011 (N/A)	10 x 2 1/4 Fayette (Bonded Shoes)	
6004	10 x 2 1/4 AL-KO 10 x 2 1/4 Hayes	Boxed
6005	12 x 2 AL-KO	Boxed

Bearing Set (L44610 Cup L44649 Cone)

Part No.	Description	Packaging
5502	7 1/4 x 1 1/4 Hayes (In & Out) 7 1/4 x 1 1/4 Foreman (In & Out) 7 x 1 1/4 Dexter BTL (In & Out) 7 x 1 1/4 Dexter BTR (In & Out) 7 1/4 x 1 1/4 Fayette (In & Out) 7 1/4 x 1 1/4 Foreman (In & Out) 10 x 1 5/8 Hayes (Out) 10 x 1 1/2 Dexter (Out) 10 x 2 1/4 AL-KO (Out) 10 x 2 1/4 Hayes (Out) 10 x 2 1/4 Dexter (Out) 10 x 2 1/4 Fayette (Out) 10 x 2 1/4 Foreman (Out)	Clam Shell

Bearing Set (25520 Cup 25580 Cone)

Part No.	Description	Packaging
5503	12 x 2 AL-KO (In) 12 x 2 Hayes (In) & 12 x 2 Hayes Centerline (In) 12 x 2 Dexter (In) & 12 x 2 Dexter 7K (In) 12 x 2 Fayette (In) 12 x 2 Foreman (In) 12 x 2 AL-KO (In) 6 & 8 Hole	Clam Shell

Bearing Set (L68111 Cup L68149 Cone)

Part No.	Description	Packaging
5505	10 x 2 1/4 AL-KO (In) 10 x 2 1/4 Fayette (In) (After 1972) 10 x 2 1/4 Hayes (In) (After 1972) 10 x 2 1/4 Dexter (In) (After Dec. 1983) 12 x 2 Foreman (In) 12 x 2 AL-KO (In) 6 & 8 Hole	Clam Shell

Bearing Set (LM48510 Cup LM48548 Cone)

Part No.	Description	Packaging
5506	10 x 2 1/4 Dexter (In) (Prior Dec. 1983) 10 x 2 1/4 Foreman (In) 10 x 2 1/4 Fayette (In) (Prior 1972)	Clam Shell

Bearing Set (L44610 Cup L44649 Cone)

Part No.	Description	Packaging
5507	10 x 1 5/8 Hayes (In) 10 x 1 1/2 Dexter (In) 12 x 2 Hayes (Out) & 12 x 2 Hayes Centerline (Out) 12 x 2 Dexter (Out) 12 x 2 Fayette (Out) 12 x 2 Foreman (Out)	Clam Shell

Bearing Set (14276 Cup 14125A Cone)

Part No.	Description	Packaging
5508	12 x 2 Dexter 6K & 7K 865 Hub (Out) 12 x 2 AL-KO 8 Hole 865 Hub (Out)	Clam Shell

Bearing Set (15245 Cup 15123 Cone)

Part No.	Description	Packaging
5509	12 x 2 Dexter 6K & 7K UTG Hub (Out) 12 x 2 AL-KO 6 & 8 Hole (865 Small)	Clam Shell

(N/A) – No Longer Available

* (Replace in pairs)



Return Spring Set (Axle Set)

Part No.	Description	Packaging
5304	10 x 2 1/4 AL-KO 10 x 1 5/8 Hayes 10 x 2 1/4 Hayes (Single Retractor) 10 x 2 1/4 Fayette	Clam Shell
5305	10 x 2 1/4 Hayes (Dual Retractor - Prior to May 1977) 10 x 2 1/4 Dexter 10 x 2 1/4 Aimco 10 x 2 1/4 Foreman 12 x 2 Aimco 12 x 2 Dexter (Dual Retractor) & 12 x 2 Dexter 7K 12 x 2 Foreman	Clam Shell
5306	10 x 1 1/2 Dexter	Clam Shell
5307	12 x 2 AL-KO 12 x 2 Hayes 12 x 2 Dexter (Single Retractor) 12 x 2 Fayette	Clam Shell
5308 (N/A)	12 x 2 Hayes Centerline	

Hardware Kit (Axle Set)

Part No.	Description	Packaging
5320	7 x 1 1/4 Dexter	Clam Shell

Hold Down Kit (Axle Set)

Part No.	Description	Packaging
5353	10 x 2 1/4 AL-KO 10 x 2 1/4 Hayes 10 x 2 1/4 Dexter 10 x 2 1/4 Fayette 10 x 2 1/4 Aimco 12 x 2 AL-KO 12 x 2 Hayes & 12 x 2 Hayes Centerline 12 x 2 Dexter & 12 x 2 Dexter 7K 12 x 2 Fayette	Clam Shell
5355 (N/A)	10 x 1 5/8 Hayes	
5356 (N/A)	10 x 1 1/2 Dexter	

Adjusting Screw Kit (Spring & Screw Assembly)

Part No.	Description	Packaging
5404	10 x 2 1/4 AL-KO 10 x 1 5/8 Hayes 10 x 1 1/2 Dexter 10 x 2 1/4 Hayes 10 x 2 1/4 Dexter 10 x 2 1/4 Fayette 10 x 2 1/4 Aimco 12 x 2 AL-KO 12 x 2 Hayes & 12 x 2 Hayes Centerline 12 x 2 Dexter & 12 x 2 Dexter 7K 12 x 2 Fayette 12 x 2 Aimco 12 x 2 Foreman	Clam Shell
5406 (N/A)	Use 5404	

Adjusting Screw Spring Set (Not Pictured)

Part No.	Description	Packaging
5407	10 x 1 5/8 Hayes 10 x 1 1/2 Dexter 10 x 2 1/4 Hayes 10 x 2 1/4 Dexter 10 x 2 1/4 Fayette 10 x 2 1/4 Aimco 12 x 2 Hayes 12 x 2 Dexter 12 x 2 Fayette	Clam Shell

Adjusting Slot Plug (Not Pictured)

Part No.	Description	Packaging
5410 (N/A)	All Systems	



Rim Clamps

RIM CLAMPS

Rim clamps are used with demountable hub and drums on mobile home type rims.

Note: Rim clamp bolt and rim clamp nut also required.

Part No.	Description	Packaging
5790	Rim Clamps - Set of 5	Clam - Tekonsha



Rim Clamp Bolts

RIM CLAMP BOLTS

Rim clamp bolts are used with demountable hub and drums on mobile home type rims.

Note: Rim clamp and rim clamp nut also required.

Part No.	Description	Packaging
5791	Rim Clamp Bolts - (1/2 - 20 x 1 7/8") - Set of 5	Clam - Tekonsha
5792	Rim Clamp Bolts - (1/2 - 13 x 1 5/8") - Set of 5	Clam - Tekonsha
5793	Rim Clamp Bolts - (1/2 - 13 x 2 1/4") - Set of 5	Clam - Tekonsha



Spindle Nuts Kits - Standard Washer

SPINDLE NUT KITS

Secures brake hardware on spindle axles.

Part No.	Description	Packaging
5774	Spindle Nut Kit - Standard Washer - (1" - 14 Spindle)	Clam - Tekonsha
5775	Spindle Nut Kit - D Type Washer - (1" - 14 Spindle)	Clam - Tekonsha



Spindle Nuts Kits - D Type Washer



Wheel Nuts

WHEEL NUTS/BOLTS

Secures wheel to brake drum.

Part No.	Description	Packaging
5780TEK	13/16 Wheel Nut - (1/2 - 20) - Set of 5	Clam - Tekonsha
5787	Wheel Bolt - (1/2 - 20) - Set of 5	Clam - Tekonsha



Wheel Bolts

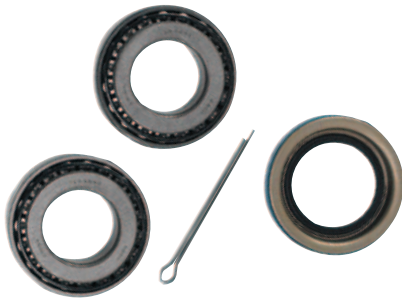

FULTON

WHEEL BEARING KITS

- Designed to fit most hubs used on boat, utility, snowmobile, and RV trailers
- Kit includes 2 bearing cones, 2 bearing cups, grease seal, and cotter pin

Part No.	Spindle Outer Diameter	Hub Diameter
WB100 0700	1"	1.980"
WB106 0700	1-1/16"	1.980"
WB138T0700*	1-3/8" x 1-1/16"	1.980"

Minimum order quantities may apply. *T applies to tapered axle applications.



FULTON

Bearing»Life®

BEARING PROTECTORS

- Protects wheel bearings from the elements during all trailer operations
- Automatically maintains the correct internal pressure – cannot damage seals
- Chrome-plated steel construction
- Sold in pairs and are available in bulk or full color display packages
- Some models include vinyl cover (see chart)

Part No.	Description	Hub Diameter
BPC1780604*	Bearing protector/clam pack, with covers	1.780"
BPC1980604*	Bearing protector/clam pack, with covers	1.980"
BP232S0604*	Bearing protector/clam pack	2.328"
BP244S0604*	Bearing protector/clam pack	2.441"
BB17810112*	Bearing protector covers	1.780"
BB19800112*	Bearing protector covers	1.980"
BB24410112*	Bearing protector covers	2.328" and 2.441"
000612	Bearing protector covers	2"

Minimum order quantities may apply.

*Bulk versions also available. Contact your sales representative.

PLASTIC FENDERS



PLASTIC FENDERS

- High density polyethylene (HDPE) fenders
- Injection molded
- Corrosion proof
- Impact resistant, 300 lb. capacity
- Molded-in color is “scratch proof”
- Built-in fender skirt
- Optional integral step pad
- Handles temperature extremes
- Mounting slots



Note: Lights not included.

Dimensional Information

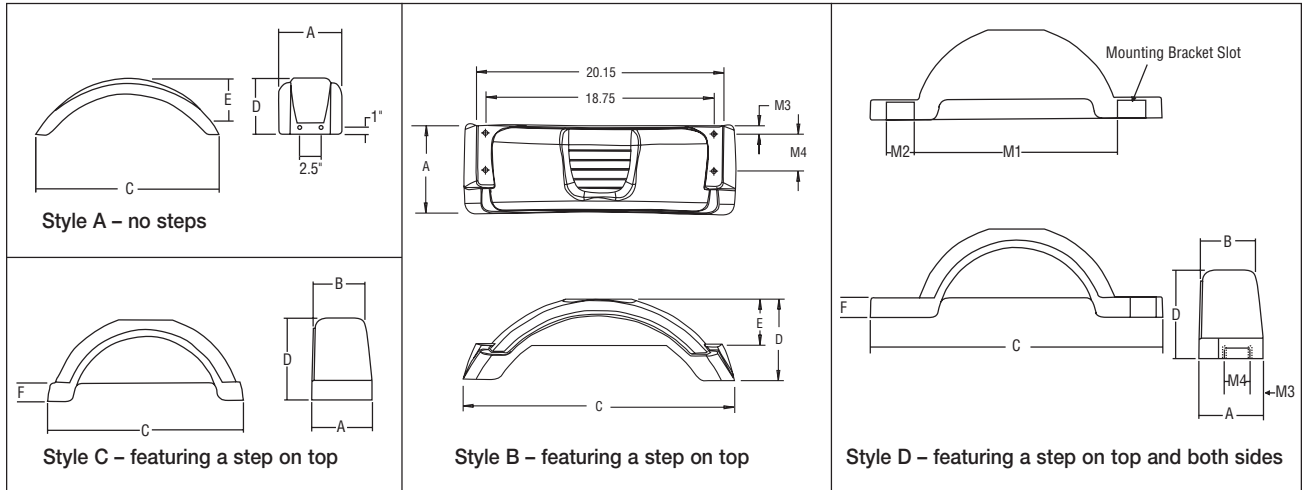

PLASTIC FENDERS

Style A

Part No. Bulk White	Part No. Bulk Black	Part No. Bulk Silver	Tire Size	Measurements (See Diagram)										Unit Wt. Lbs.
				A	B	C	D	E	F	M (1)	M (2)	M (3)	M (4)	
008540*	008550*	—	8"-12"	7.00"	—	20.25"	6.25"	4.62"	—	—	—	2.25"	2.50"	1

Style B

Part No. Bulk White	Part No. Bulk Black	Part No. Bulk Silver	Tire Size	Measurements (See Diagram)										Unit Wt. Lbs.
				A	B	C	D	E	F	M (1)	M (2)	M (3)	M (4)	
008549	008559	008569	8"-12"	7.35"	—	22.30"	6.50"	3.75"	2.18"	—	—	.075"	3.00"	1-1/4

Style C

Part No. Bulk White	Part No. Bulk Black	Part No. Bulk Silver	Tire Size	Measurements (See Diagram)										Unit Wt. Lbs.
				A	B	C	D	E	F	M (1)	M (2)	M (3)	M (4)	
008541*	008551*	008561	8"-12"	7.35"	7.35"	21.80"	6.50"	3.75"	2.18"	—	—	2.43"	2.50"	1
008543	008553	008563	13"	9.00"	7.70"	29.25"	12.00"	—	2.75"	—	—	—	—	3
—	008554	008564	14"	9.70"	8.00"	31.30"	12.75"	—	3.00"	—	—	—	—	3-3/4

Style D (US Patent D385, 512)

Part No. Bulk White	Part No. Bulk Black	Part No. Bulk Silver	Tire Size	Measurements (See Diagram)										Unit Wt. Lbs.
				A	B	C	D	E	F	M (1)	M (2)	M (3)	M (4)	
008572	008582	008592	12"	7.50"	6.90"	33.50"	8.75"	—	2.50"	22.70"	4.00"	1.50"	3.00"	2-1/2
008573	008583	008593	13"	9.00"	7.70"	40.00"	12.00"	—	2.75"	28.00"	4.00"	2.12"	3.75"	3-3/4
008574	008584	008594	14"	9.70"	8.00"	43.40"	12.75"	—	3.00"	30.00"	4.00"	2.12"	3.75"	4-3/4
008575	008585	008595	15"	10.25"	6.70"	45.00"	14.85"	—	3.00"	34.00"	4.00"	2.12"	3.75"	5-3/4

* Minimum order quantities may apply.



67300



HINDSIGHT™ CAMERA SYSTEM

- Application use is completely wireless
- Night Vision
- Wide 55° viewing
- Viewing distance over 300 feet without obstruction (actual transmission distance may be reduced by certain obstructions)
- Full color portable 2.4" LCD monitor with 480 x 240 resolution
- 4 Channel monitor allows for multiple cameras
- Instant reverse image of monitor viewing
- Microphone built into camera
- Quick rechargeable lithium-ion batteries
- Complies to FCC regulation

Part No.	Description	Packaging
67300	HindSight Single Back-Up Camera System w/Magnetic Base	Clam - Tow Ready

Accessory Parts

New

Part No.	Description	Packaging
67302	HindSight Single Back-Up Camera, Channel 2	Boxed
67303	HindSight Single Back-Up Camera, Channel 3	Boxed
67304	HindSight Single Back-Up Camera, Channel 4	Boxed



63300

HITCH & TRAILER ALIGNMENT TOOL

- Convenient one person hitch alignment system
- Magnetic base for fast and easy location
- Telescoping rods adjust up to 42"
- Easy to use the first time

Part No.	Description
63300	Hitch & Trailer Alignment Tool



63450

TIRE CHOCK & TONGUE JACK CASTER & WHEEL DOCK COMBO



- Complete trailer docking system
- Made from high impact polymer
- Mounting holes provided to secure to solid surface
- Reduces the risk of trailer roll
- Fits most trailer wheels

Part No.	Description
63450	Tire Chock & Tongue Jack Caster Wheel Dock Combo



7000100

WHEEL CHOCK



- Made from high impact polymer
- Reduces the risk of trailer roll
- Fits most trailer wheels

Part No.	Description
7000100	Wheel Chock

EZ MOVE™ TRAILER HANDLE



Take the wrestle out of trailer wrangling and stop breaking your jack handle. Whether the job is man-handling a trailer, mounting it, or un-mounting it, the EZ Move™ trailer handle reduces strain and improves control. This simple, innovative solution is ideal for boat, cargo, utility and vehicle trailers because it efficiently improves ease of use without interfering with trailer operation.

- Provides superior trailer control when moving and coupling
- Reduces the effort of moving a trailer by hand
- Improves the precision of trailer positioning
- Makes lifting trailer tongue more ergonomic
- Installs easily with no special tools or drilling
- Fits most trailer tongues with or without jacks
- Soft handle for comfort
- Zinc plated



EM0101

Part No.	Description	Packaging
EM0101	EZ Move™ Trailer Handle w/Mounting Hardware	Ind. Box

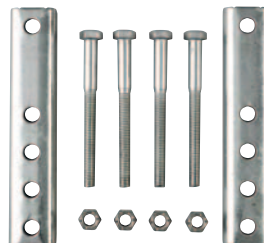

← Mounts On Tongue Without Jack

SAFETY CHAINS



CHA0010340



CHA0040324



CHA0060324



CHA0020324

FULTON

SAFETY CHAINS

- Safety chains are required by law in most states
- Cross chains when towing for added safety
- All chains conform to J684.6.3.4 SAE standards

Part No.	Grade	Size	Hook	Finish	Capacity	Description	Packaging
CHA0010140	30	1/4 x 24"	7/16" Safety Hook	Clear Zinc	5,000 lbs.	Proof coil chain. 1/4" chain interior dimension is sized so a 1/2" bolt shank can pass through. (2-pack)	Clam Shell
CHA0010340	30	1/4 x 24"	7/16" Safety Hook	Clear Zinc	5,000 lbs.	Proof coil chain. 1/4" chain interior dimension is sized so a 1/2" bolt shank can pass through.	Bulk
CHA0020324	70	1/4" x 36"	1/4" Forged Clevis Hook	Yellow Zinc	12,600 lbs.	Transport chain. 1/4" chain interior dimension is sized so a 1/2" bolt shank can pass through.	Bulk
CHA0030140	43	1/4 x 24"	7/16" Safety Hook	Clear Zinc	7,800 lbs.	Test chain. 1/4" chain interior dimension is sized so a 1/2" bolt shank can pass through. (2-pack)	Clam Shell
CHA0030340	43	1/4 x 24"	7/16" Safety Hook	Clear Zinc	7,800 lbs.	Test chain. 1/4" chain interior dimension is sized so a 1/2" bolt shank can pass through.	Bulk
CHA0040324	70	5/16" x 36"	5/16" Forged Clevis Hook	Yellow Zinc	18,800 lbs.	Transport chain.	Bulk
CHA0050324	70	5/16" x 42"	5/16" Forged Clevis Hook	Yellow Zinc	18,800 lbs.	Transport chain.	Bulk
CHA0060324	70	3/8" x 36"	3/8" Forged Clevis Hook	Yellow Zinc	26,400 lbs.	Transport chain.	Bulk
CHA0070324	70	1/2" x 42"	1/2" Forged Clevis Hook	Yellow Zinc	45,200 lbs.	Transport chain.	Bulk



63035



5592



SAFETY CHAIN KIT



Part No.	Max GTW	Description
63034	2,000	6' Class I - S-Hooks on Both Ends (1pc)
63035	5,000	6' Class III - Quick Links on Both Ends (1pc)

SAFETY CHAIN KIT (BULK PACKAGED)

Part No.	Max GTW	Description
5592	3,500	6' Class II - 1/4" Proof Coil Chain.
2489	5,000	30" Class III - Straight Link Machine Chain

CLASS I-III CHAIN WITH S-HOOK, ONE END

Part No.	Description
49138	Class II GVWR 3,500 lbs. 24", 1/4" Proof Coil Grade 30, with S-Hook at One End (836)
49141	Class III GVWR 5,000 Lbs. 30", 1/4" Proof Coil Grade 30, with S-Hook at One End (839)

CLASS I-III SAFETY CHAIN WITH S-HOOK, BOTH ENDS

Part No.	Description
49137	Class I GVWR 2,000 Lbs. 48", 3/16" Proof Coil Grade 30, S-Hook, Both Ends (835)
44140	Class III GVWR 5,000 Lbs. 48", 1/4" Proof Coil Grade 30, S-Hook, Both Ends (839)

CLASS IV SAFETY CHAIN WITH CLEVIS HOOK

Part No.	Description
49148	Class IV 32", 5/16" Proof Coil Grade 30 5/16" Clevis Slip Hook, One End (7,600 lbs. GVW)
49149	Class IV 36", 1/2" proof Coil Grade 30 3/8" Clevis Slip Hook, One End (10,600 lbs. GVW)
49147	Class IV 35", 3/8" High Test 43 Clevis Slip & Latch Hook (16,200 lbs. GVW)



FORGED D-RINGS, FORGED LASHING RINGS & BRACKETS



Part No.	Description	Work Load (lbs.)	Max Load (lbs.)
63024	Forged D Ring Yellow Zinc, 1/2" Forged D-Ring with Mounting Bracket, Measures 2-1/2" X 2-3/8" ID	4,000	12,000
63025	Forged Lashing Ring 18,000 lbs. 3/8" C1045 Material 5/8" Forged D-Ring with Weld Mounting Bracket	6,000	18,000
63026	Forged Lashing Ring 26,500 lbs. 3/8" Thick, C1045 Material 3/4" Forged D-Ring with Weld Mounting Bracket	8,833	26,500
63027	1" Forged D-Ring with Weld On Mounting Bracket, 3/8" Thick	15,587	46,760
63028	1x5x6 Forged Lashing Ring 46,760 lbs. C1045 Material 5/8" Forged D-Ring with Weld Mounting Bracket	15,587	46,760
44200	Recessed Rope Ring for 3/8" Plywood	400	1,200
44201	Rope Ring, Zinc 10 gauge	400	1,200
44202	Recessed Rope Ring & Trim Ring Zinc 16 gauge Steel for 1/4" Plywood	333	1,000
44203	Replacement Plastic Trim for #44202		
44209	Recessed Floor/Wall Tie Downs 1/8" Plate Steel	1,667	5,000



TOW HOOKS (BULK PACKAGED)

Part No.	Description	Max. GTW (lbs.)
63029	Tow Hook with Mounting Bolts (Chrome)	10,000
63030	Tow Hook with Mounting Bolts (Black)	10,000



S-HOOKS FOR TRAILER SAFETY CHAIN

Part No.	Description
44150	S-hook for Trailer Safety Chain, Class I, Break Strength 2,000 lbs.
44153	S-hook for Trailer Safety Chain, Class II/III, Break Strength 5,000 lbs.
49152	S-hook for Trailer Safety Chain, Class IV, Break Strength 7,600 lbs.



QUICK LINKS (BULK PACKAGED)

- Use to connect safety chains to tow vehicle or trailer

Part No.	Max GTW	Description
74701	3,500	1/4" Quick Link, Fits 3/16" or 1/4" Chain
74700	5,000	5/16" Quick Link, Fits 5/16" Chain
49132	3,500	1/4" Quick Link
49131	3,500	5/16" Quick Link
44133	3,500	3/8" Quick Link
49134	5,000	7/16" Quick Link
49135	10,000	1/2" Quick Link
74603	3,500	1/4" Quick Link, Fits 3/16" or 1/4" Chain - Packaged
74602	5,000	5/16" Quick Link, Fits 5/16" Chain - Packaged



CLEVIS SLIP HOOKS W/ LATCH FOR TRAILER SAFETY CHAIN

Part No.	Description
44154	Grade 43, Clevis Slip with Latch, 1/4"
44155	Grade 43, Clevis Slip with Latch, 5/16"
44156	Grade 43, Clevis Slip with Latch, 3/8"
44157	Grade 43, Clevis Slip with Latch, 1/2"
44163	Grade 70, Clevis Hook with Latch, 1/4"
44159	Grade 70, Clevis Hook with Latch, 5/16"
44164	Grade 70, Clevis Hook with Latch, 3/8"

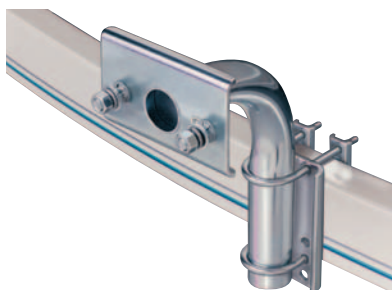

SPARE TIRE CARRIER

- Fits most 4, 5 and 6 lug wheels - up to 16-1/2"
- Provides 4-3/4" lift and over 7" of offset to mount tire up and out of the way
- Zinc-plated to resist corrosion
- Easy bolt-on installation, no cutting or drilling required
- Fits trailer tongue up to 3" wide by 5" high
- All mounting hardware and instructions included

Part No.	Description	Packaging
HDSTC 0101	Spare tire carrier	Bulk

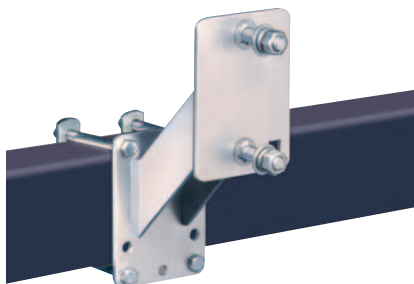

HI-MOUNT SPARE TIRE CARRIER

- Heavy-duty, welded and reinforced steel plate construction
- Zinc-plated to resist corrosion
- Adjustable bolt circle to fit both 4 and 5 lug wheels
- Fits all trailer tongues up to 3" wide by 4" high
- Includes zinc-plated mounting hardware and instructions
- Security locking hole to lock wheel and bracket to trailer using a security cable and lock (cable and lock sold separately).

Part No.	Description	Packaging
STC1000101	Hi-mount spare tire carrier	Ind. Box
STC1000301	Hi-mount spare tire carrier	Bulk

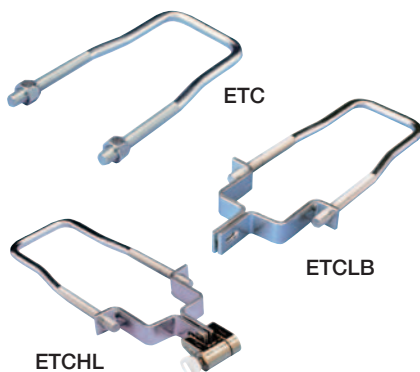

ECONOMY SPARE TIRE CARRIER

- Fits 8", 9", 12", 13", 14", and 15" wheels with 4 or 5 lug rims
- Easy to install
- Includes lug nuts to secure wheel to frame
- Heavy-duty 1/2" diameter construction
- Zinc-plated to resist corrosion

Part No.	Description	Packaging
ETC 0101	Economy spare tire carrier	Ind. Box
ETCLB 0201	Economy spare tire carrier with locking levers	Bulk
ETCLB 0700	Economy spare tire carrier with locking levers	Clam Shell
ETCHL 0700	Economy spare tire carrier with locking levers and HLO lock	Bulk

ECONOMY ETC & SPARE TIRE LOCK

- Tested tough
- Theft-resistant locking cap
- Fits over wheel studs (up to 9/16" diameter) to deter spare tire theft
- Removable plug allows longer wheel studs to protrude through cap
- Locking tab provides positive locking feature to prevent lock from turning

Part No.	Description	Packaging
ETCSTL0701	Economy spare tire carrier with STL spare tire lock	Bulk
STL 0603	Spare tire lock	Bulk



PICKUP TIRE CARRIER (INSIDE BED)

- Coated with epoxy, electro-static paint that is highly resistant to impact or scratches
- Padlock feature secures the wheel against theft (padlock not included)
- Black powder coat finish



Part No.	Description
1240	Universal Application for 1960-1998 Domestic Pickups

Can be used with 14" through 16.5" wheel sizes with 7" maximum rim width. Will not fit imports and some models of small pickups.



F2® HEAVY DUTY WELD-ON SPARE TIRE CARRIER

- Weld-on model
- One piece steel construction
- Accommodates 12" to 14" spare tires
- Works with 4 and 5 bolt rims
- Designed to mount on 2" to 4" trailer frames
- Supports cable locks
- Includes spare tire mounting hardware
- Limited 5-year warranty

Part No.	Description	Finish	Packaging
581900	F2® Heavy Duty Spare Tire Carrier (Weld-On)	Raw	Bulk

US Patent D603,780



F2® SUPER DUTY WELD-ON SPARE TIRE CARRIER

- Offset model available to clear boat hulls, 17°
- Weld-on model
- One piece steel construction
- Accommodates 15" to 20" spare tires
- Works with 5, 6 and 8 bolt rims
- Designed to mount on 3" to 5" trailer frames
- Supports cable locks
- Includes spare tire mounting hardware
- Limited 5-year warranty

Part No.	Description	Finish	Packaging
581901	F2® Super Duty Spare Tire Carrier, Offset (Weld-On)	Raw	Bulk

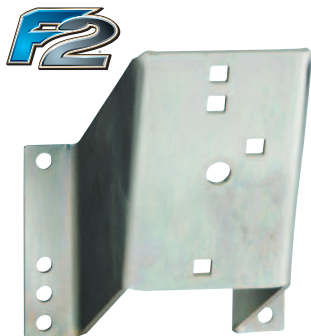

F2® SUPER DUTY BOLT-ON SPARE TIRE CARRIER

- Offset to clear boat hulls, 17°
- Bolt-on model
- One piece steel construction
- Z-Max 600-hour Plating
- Accommodates 15" to 20" spare tires
- Works with 5, 6 and 8 bolt rims
- Designed to mount on 3" to 5" trailer frames
- Supports cable locks
- Includes spare tire mounting hardware
- Limited 5-year warranty



Part No.	Description	Finish	Packaging
581903	F2® Super Duty Spare Tire Carrier, Offset (Bolt-On)	Z-Max 600	Ind. Box
581906	F2® Super Duty Spare Tire Carrier, Offset (Bolt-On)	Z-Max 600	Bulk



F2® HEAVY DUTY BOLT-ON SPARE TIRE CARRIER

- Offset model available to clear boat hulls, 17°
- Bolt-on model
- One piece steel construction
- Z-Max 600-hour Plating
- Accommodates 12" to 14" spare tires
- Works with 4 and 5 bolt rims
- Designed to mount on 2" to 4" trailer frames
- Supports cable locks
- Includes spare tire mounting hardware
- Limited 5-year warranty



Part No.	Description	Finish	Packaging
581902	F2® Heavy Duty Spare Tire Carrier (Bolt-On)	Z-Max 600	Ind. Box
581905	F2® Heavy Duty Spare Tire Carrier (Bolt-On)	Z-Max 600	Bulk
581904	F2® Heavy Duty Spare Tire Carrier, Offset (Bolt-On)	Z-Max 600	Ind. Box
581907	F2® Heavy Duty Spare Tire Carrier, Offset (Bolt-On)	Z-Max 600	Bulk

US Patent D605,102 - 581902, 581905



BGR20

BOAT GUIDES

Boat guides help you visually guide your boat onto your trailer. High-strength super gripper mounting brackets attach firmly above and below the trailer frame. Easy bolt-on mounting fits trailer frames up to 3" x 5" high. Adjustable to provide optimum fit to any hull design.

Part No.	Description	Upright Height
GB44 0101	Non-marring, marine grade PVC tubing	44"
GB150 0100	Non-marring, marine grade PVC tubing	50"
BGR20 0101	Galva-Tec® finish, steel construction with non-marring, cushioned rollers	20"



GB150

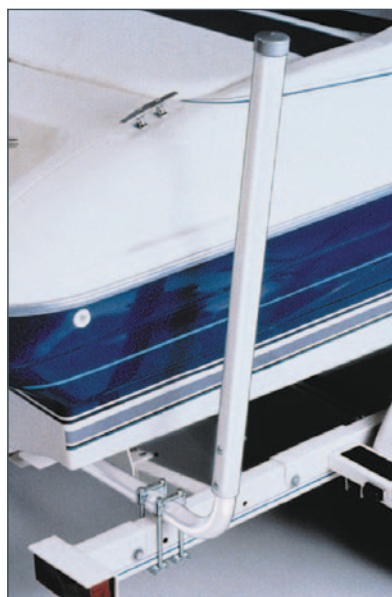

GB44



Replacement Bunk Carpeting

MARINE GRADE CARPETING

Marine Grade carpeting allows the do-it-yourselfer to replace worn and dirty carpet on bunk trailers. The carpet protects your boat investment by reducing scratching on the hull and keeps it in like-new condition. Individual rolls are shrink-wrapped for shelf display.

Part No.	Description
CR8008	Bunk carpeting, Black, 8" x 144"
CR8012	Bunk carpeting, Black, 12" x 144"

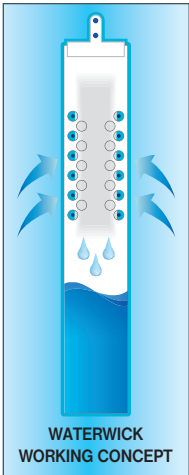

WaterWick

- Absorbs moisture from the air
- Helps control mold and mildew
- Contains 1.65 lbs/750 grams of Calcium Chloride (salt), that can absorb up to 1/4 gallon of moisture
- 32" long (with hook extended), 1.88 lbs.
- Designed for use in RVs, Trailers, Boats

Part No.	Description
1000750	WaterWick™

US Patent 6.273.942. B1

WATERWICK RECOMMENDED USAGE

Square Feet	Humidity	# of Units
Up to 30	Low	1-2
	High	2-3
Over 30	Low	2-3
	High	3-4



General guidelines only. Number of units needed may vary depending on your specific needs.

NOTE: Contains Calcium Chloride (salt). Possible adverse effects in case of contact with eyes. Please read caution on instructions sheet.



ASSIST BARS

Zinc die cast assist bar with chrome plating or black powder coat and textured finish. Requires counter sunk screws.

10" X 7/8" X 1 5/8"

Mounting holes on 9" centers.

Part No.	Description
70-33-301	Assist Bar, Chrome
70-33-302	Assist Bar, Black



DOOR BUMPERS

Rubber cushion with counter sunk hole, suitable for use on metal or wood.

Part No.	Description
70-14-002	Door Bumper Black w/Screw
70-14-003	Door Bumper White w/Screw

Replacement Parts

Part No.	Description
70-14-110	Door Bumper Screw



DOORS - ELECTRIC

Electric door with flange, rain deflector and full square opening, with door cutout for cord.

Cutout: 6 3/4" X 6 3/4",
Overall: 9 3/8" X 9 3/8"

Bulk Part No.	Bagged Part No	Description
60-10-001		Door - Electric Colonial White (EB350)
60-10-002		Door - Electric Original White #2 (EB350)
60-10-006		Door - Electric Soft White #3 (EB350)

Replacement Parts

60-10-090		Lock 1.25"
60-10-092		Clip
60-10-093	64-10-093	Key CH751 - Set of 2
	64-10-090	Lock 1.25" w/Clip & Key



DOORS - ELECTRIC

Electric door with flange, rain deflector and full opening, with door cutout for cord.

Cutout: 4 7/8" X 5 7/8",
Overall: 7 5/8" X 6 1/2"

Bulk Part No.	Bagged Part No	Description
60-14-002		Door - Electric 30 Amp Original White #2 (EB390)
60-14-006		Door - Electric 30 Amp Soft White #3 (EB390)

Replacement Parts

60-10-091		Lock .675"
60-10-092		Clip
60-10-093	64-10-093	Key CH751 - Set of 2
	64-10-091	Lock .675" w/Clip & Key

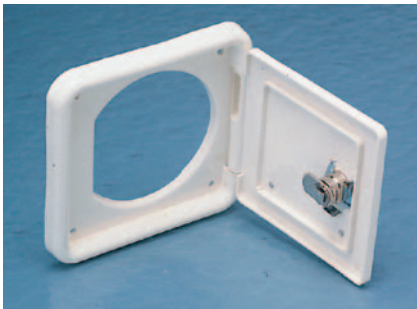

DOOR - LIFT SYSTEM

Lift system door with flange.

Cutout: 4" dia.,
Overall: 5 1/2" X 5 1/2"

Bulk Part No.	Bagged Part No	Description
60-28-002		Door - Lift System Original White #2 (LS456)

Replacement Parts

60-10-064		Thumb Lock .675"
60-10-065		Clip
	64-10-064	Thumb Lock .675" w/Clip



DOORS - GAS FILL

Gas fill door with molded plastic shroud.
 Cutout: 7" X 7"
 Overall: 9 7/16" X 9 7/16"

Bulk Part No.	Bagged Part No	Description
60-16-001		Door - Gas Fill Colonial White (GF250)
60-16-002		Door - Gas Fill Original White #2 (GF250)
60-16-006		Door - Gas Fill Soft White #3 (GF250)

Replacement Parts

60-10-090		Lock 1.25"
60-10-092		Clip
60-10-093	64-10-093	Key CH751 - Set of 2
	64-10-090	Lock 1.25" w/Clip & Key

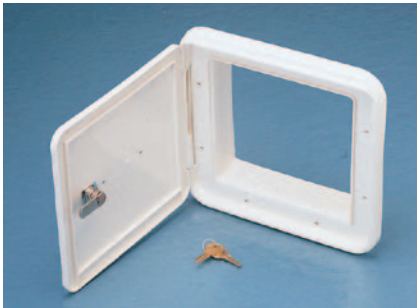

DOORS - GAS FILL

Gas fill door with flange, rain deflector and open back.
 Cutout: 7" X 7"
 Overall: 9 7/16" X 9 7/16"

Bulk Part No.	Bagged Part No	Description
60-18-001		Door - Gas Fill Colonial White (GF255)
60-18-002		Door - Gas Fill Original White #2 (GF255)

Replacement Parts

60-10-090		Lock 1.25"
60-10-092		Clip
60-10-093	64-10-093	Key CH751 - Set of 2
	64-10-090	Lock 1.25" w/Clip & Key



DOORS - GAS FILL

Gas fill door with open back and rain deflector. Flat frame.
 Overall: 9 7/16" X 9 7/16"

Bulk Part No.	Description
60-20-001	Door - Gas Fill Colonial White (GF260)
60-20-002	Door - Gas Fill Original White #2 (GF260)

Replacement Parts

60-10-062	Lock 1.5"
60-10-065	Clip
60-10-066	Key - Set of 2



DOOR - WATER FILL

City water fill door.
Cutout: 4" dia.,
Overall: 5 1/2" X 5 1/2"

Bulk Part No.	Bagged Part No	Description
60-32-006		Door - City Water Fill Soft White #3 (WF465)

Replacement Parts

60-10-091		Lock .675"
60-10-092		Clip
60-10-093	64-10-093	Key CH751 - Set of 2
	64-10-091	Lock .675" w/Clip & Key



DOOR - WATER FILL

Gravity water fill door.
Cutout: 4" dia.,
Overall: 5 1/2" X 5 1/2"

Bulk Part No.	Bagged Part No	Description
60-30-001		Door - Gravity Water Fill Colonial White (WF450)
60-30-002		Door - Gravity Water Fill Original White #2 (WF450)
60-30-006		Door - Gravity Water Fill Soft White #3 (WF450)

Replacement Parts

60-10-091		Lock .675"
60-10-092		Clip
60-10-093	64-10-093	Key CH751 - Set of 2
	64-10-091	Lock .675" w/Clip & key
60-44-701	64-44-701	Low Pressure Water Cap & Strap



DOOR - WATER FILL

City and gravity water fill door, with door cutout for hose.
Cutout: 4" X 5 7/8",
Overall: 8 3/16" X 6 5/16"

Bulk Part No.	Bagged Part No	Description
60-34-001		Door - City/Gravity Water Fill Colonial White (WF480)
60-34-002		Door - City/Gravity Water Fill Original White #2 (WF480)
60-34-006		Door - City/Gravity Water Fill Soft White #3 (WF480)

Replacement Parts

60-10-090		Lock 1.25"
60-10-092		Clip
60-10-093	64-10-093	Key CH751 - Set of 2
	64-10-090	Lock 1.25" w/Clip & Key
60-44-701	64-44-701	Low Pressure Water Cap & Strap

VEHICLE ACCESSORIES

VEHICLE ACCESSORIES

HindSight™ Camera System

Loading Ramps

Truck/Trailer Anchoring Systems

Tow Bars

Transmission Coolers and Accessories

Battery Post Adapter

Battery Isolators

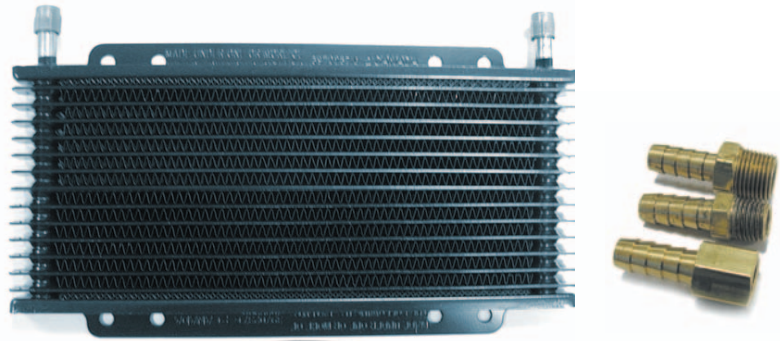



67300



HINDSIGHT™ CAMERA SYSTEM

- Application use is completely wireless
- Night Vision
- Wide 55° viewing
- Viewing distance over 300 feet without obstruction (actual transmission distance may be reduced by certain obstructions)
- Full color portable 2.4" LCD monitor with 480 x 240 resolution
- 4 Channel monitor allows for multiple cameras
- Instant reverse image of monitor viewing
- Microphone built into camera
- Quick rechargeable lithium-ion batteries
- Complies to FCC regulation

Part No.	Description	Packaging
67300	HindSight Single Back-Up Camera System w/Magnetic Base	Clam - Tow Ready

Accessory Parts

New

Part No.	Description	Packaging
67302	HindSight Single Back-Up Camera, Channel 2	Boxed
67303	HindSight Single Back-Up Camera, Channel 3	Boxed
67304	HindSight Single Back-Up Camera, Channel 4	Boxed



1120500

STRAIGHT ALUMINUM LOADING RAMP

- Welded aluminum construction
- Rust and corrosion resistant
- Adjustable attachment strap
- Sold as pair

Part No.	Description
1120500	69" Straight Aluminum Loading Ramp, 1,250 lbs. Capacity (625 lbs. per Ramp)



1123000

STRAIGHT STEEL LOADING RAMP

- One piece steel construction
- Rust and corrosion resistant

Part No.	Description
1123000	69" Straight Steel Loading Ramp, 600 lbs. Capacity



1123100

ARCHED ALUMINUM LOADING RAMP

- Center-fold for easy storage
- Arched for easier loading
- Welded aluminum construction
- Rust and corrosion resistant
- Adjustable attachment strap
- Sold as pair

Part No.	Description
1123100	Arched Aluminum Center-Fold Loading Ramp, 1,500 lbs. Capacity (750 lbs. per Ramp)



1120800

SPORTMAX UTILITY RAMP

- Lightweight aluminum construction
- Rust and corrosion resistant

Part No.	Description
1120800	69" length x 15" width Bi-Fold Utility Ramp, Pair, 1,400 lbs. Capacity (700 lbs. per Ramp)



1122600

TRI-FOLD UTILITY RAMP

- Lightweight aluminum construction
- Rust and corrosion resistant
- Item Qty: Single

Part No.	Description
1121400	69" length x 45" width Tri-Fold Utility Ramp, 1,500 lbs. Capacity
1121500	77" length x 54" width Tri-Fold Utility Ramp, 1,500 lbs. Capacity
1122600	69" length x 45" width Tri-Fold Loading Ramp, 1,400 lbs. Capacity



1121300

CENTER FOLDING LOADING RAMP

- Lightweight aluminum construction
- Item Qty: Single

Part No.	Description
1121300	85" length x 12" width Center Fold Loading Ramp, 700 lbs. Capacity



1340000



Removable eyelet for a flush mounting system

UNIVERSAL ANCHORING SYSTEM



- 400 lbs. safety rating
- Heavy-Duty chrome plate finish for durability and good looks
- Heavy stainless steel top plate is sized to fit ALL vehicles
- Soft gasket prevents scratching of all painted surfaces
- Stainless steel anchor plates (2) provide exact fit for ALL vehicles

Part No.	Description
1340000	Universal Anchoring System, chrome



9250900



9252200

TRUCK ANCHOR POINTS



- Safe and secure tie down attachment with no drilling of truck
- #9250900 fits all trucks with or without bedliners
- Corrosion resistant

Part No.	Description
9250900	Universal Chrome Anchor Points, per pair
9252200	Large Stake Pocket Anchor Points, fits Dodge Ram 94-04 and all Chevrolet Silverado and GMC Sierra, Chrome



9155000

HD TRAILER HARDWARE AND BED ANCHORS



Part No.	Description
9155000	HD 3/8" Bed Anchor, per pair, 13/4" x 4", 1,400 lbs. capacity



63180



63181



40604

5,000 LBS. ADJUSTABLE TOW BARS



- Light-weight, only 31 lbs.
- Arms adjust from 26" to 41" for universal fit
- Tow bar mounting brackets bolt securely to vehicle bumper - (almost all applications will require a custom fabricated bracket due to bumper design)
- Heavy-Duty quick latch A-frame coupler fits 2" ball
- Tow bar comes assembled, complete with installation instructions
- Some states require the use of double safety chains
- Black powder coat finish

Part No.	Description
63180	Adjustable Tow Bar, 5,000 lbs. GVW, incl. mounting brackets
63181	Adjustable Tow Bar, 5,000 lbs. GVW, incl. mounting brackets w/Bolt together 2-piece adjustment arms
40604	Safety Chain Kit, Class III chains rated at 5,000 lbs.
40602	Replacement Bumper Bracket Kit
2471	Wire Lock Pin

NOTE: Total weight of towed vehicle must not exceed 5,000 lbs., or must not exceed the weight of the towing vehicle.



40602

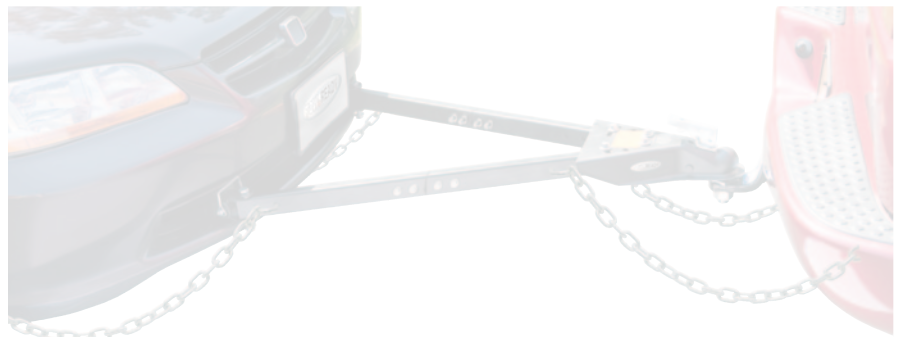



Don't Tow Without It!



TUBE AND FIN TRANSMISSION COOLERS

- Ultrasonically soldered for reliability
- 100% pressure tested at 150 psi for quality assurance
- High efficiency turbulators for maximum heat dissipation
- 3/8" push-on fittings for quick and easy installation

Part No.	Towing Class	Application	Thickness	Width	Length
41010	Light duty	Compact to mid-size cars (light duty)	3/4"	5"	12-3/4"
41011	Medium duty	Full-Size cars, mini-vans & SUVs towing up to 2,500 lbs. (med. duty)	3/4"	7-1/2"	12-3/4"
41013	Heavy duty	SUVs, vans and pick-up trucks, towing up to 5,000 lbs.	3/4"	7-1/2"	15-1/2"
41014	X-heavy duty	Pick-up trucks and motorhomes, towing over 5,000 lbs.	3/4"	10"	15-1/2"



PLATE AND FIN TRANSMISSION COOLERS

- Durable brazed aluminum construction
- Easy to install - simple instructions included
- 33% smaller than comparable tube and fin designs

Part No.	Towing Class	Application	Thickness	Width	Length
41019	Class I	Compact to mid-size cars towing under 2000 lbs.	3/4"	4"	11"
41020	Class II	Full-size cars, mini-vans & SUVs towing 2,000-3,500 lbs.	3/4"	5-3/4"	11"
41310	Class III	SUVs, vans and pick-up trucks towing 3,500-5,000 lbs.	3/4"	7-1/4"	11"
41311	Class III	Pick-up trucks and motorhomes, towing over 5,000 lbs.	3/4"	12"	11"
41312	Class V	Pick-up trucks towing fifth wheels and gooseneck trailers	1-1/2"	11"	11"



41102
3132



41103

41405

TRANSMISSION COOLER ACCESSORIES

Part No.	Description
41102	Transmission Oil Cooler Hose, 1 1/32" x 4-1/2' long
3132	Transmission Oil Cooler Hose, 1-1/32" i.d., 25' long
41103	Metal Strap Mounting Kit
41405	Nylon Tie Mount Kit (4 per bag)

OEM CUSTOM FITTING KITS

Part No.	Description
41411	1986 prior Jeep, 1991 to current FWD GM, 96 and later GMC/Chevrolet truck & van. adapter kit for 5/8"-18 inverted flare, full thread
41412	1987 and newer Jeep adapter kit for 5/8"-18, 45° S.A.E. flare
41413	1987 and newer Jeep, 1995 and later Dodge truck and vans adapter kit for quick disconnect style with rubber hose/metal line
41414	1985-1995 GM Astro and Safari vans Adapter kit for 1/2"-20 inverted flare, full thread
41410	1983 and newer Ford, Lincoln & Mercury cars adapter kit for duckbill style line fittings
41415	1983 and newer Ford, Lincoln & Mercury Cars and Ford trucks & vans, adapter kit for deep-thread style
41416	1999 and later Dodge Trucks Adapter Kit for 9/16"-18 JIC 37° Flare
41417	1987 and later Ford Aerostar, Explorer, Expedition, F-Series trucks & ranger adapter kit for 5/8"-18 inverted flare, recessed thread
41418	1996-up GMC snap-in transmission cooler fitting

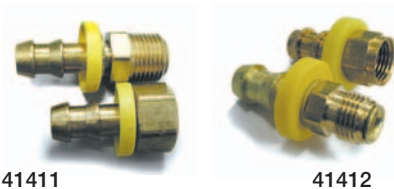

41411



41412



41413



41414



41410



41415



41417



41416



41418

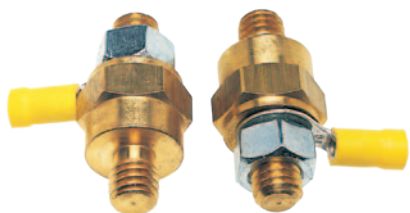

BATTERY POST ADAPTER

Battery Post Adapter for General Motors Side Post Batteries. Allows stud for attaching accessories wires.



Part No.	Description	Packaging
54-98-001	Battery Post Adapter	Bagged - Bargman
3194-S	Battery Post Adapter	Clam Shell - Tekonsha



BATTERY ISOLATORS

Cadmium plated isolator with terminal nuts and lock-washers. 3 terminal isolator for metal frame ground systems, 4 terminal has insulated ground terminal for use with fiberglass or other non-conductive materials. Isolates starting battery, provides secondary battery current for auxiliary power and full time charging of both batteries.



Part No.	Description	Packaging
7000	Battery Isolator - 3 Terminal	Bulk
54-98-002	Battery Isolator - 3 Terminal	Bagged - Bargman
7000-S	Battery Isolator - 3 Terminal	Clam - Tekonsha
7001	Battery Isolator - 4 Terminal	Bulk
54-98-004	Battery Isolator - 4 Terminal	Bagged - Bargman
7001-S	Battery Isolator - 4 Terminal	Clam Shell - Tekonsha



BATTERY ISOLATION SOLENOID

Battery isolation solenoids are used to switch the auxiliary 12v feed off when the ignition is off.



Part No.	Description	Packaging
118665	Battery Isolation Solenoid, 3 Pole, 12 Volt (Chassis Ground)	Clam - Tow Ready

TESTERS

4-Way Testers

5-Way Testers

6-Way Testers

7-Way Testers

Current Monitor

Trailer Tester

Bench Tester

Circuit Testers

TOOLS

Drill Bits & Hole Saws

Trailer Tongue Weight Scale

Hitch Ball Grease

Wire Looms



TESTERS

Plug these testers into any car connector and you will have an instant test of running light circuits. Features LED display to show completed circuit for the running lights, left turn signal and right turn signal. Auxiliary circuit LED display is included on the 5-way tester, auxiliary and electric brake are included on the 6-way tester and auxiliary, electric brake and battery charge are included with the 7-way tester. One piece units with internal ground. Dust cap included with 5-way tester can be attached to key chain to always be readily available. Proper installation and set-up of a brake control, when a trailer is not readily available, is possible with the 7-way tester.

Current Monitor testing device is designed to assist in determining whether a tow vehicle's 7-way blade car end connector has been wired properly. (Current Monitor is an excellent diagnostic tool for installation, setup and troubleshooting of electric trailer brake controls.)

The Trailer Tester is designed to help you quickly identify problems in the wiring of the trailer. This is done by testing the Left Turn, Right Turn, Tail/Marker, Brake and Back Up circuits on the trailer. The tester indicates approximate amount of current in each circuit. It will also test the voltage of the external battery connected to the trailer charge circuit (i.e. trailer battery).

Brake Control Bench Tester is a test device designed to determine if a brake control is working properly. Checks brake control output, independent of vehicle wiring. Simulates many fault conditions including open ground, short circuit, open load and more.



6565



7585

8010

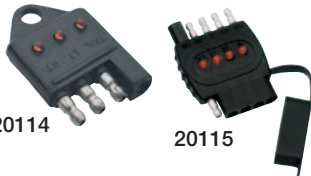

20114

20115



20116

20117



40376



3808

Part No.	Description	Packaging
51-98-005	4-Way Tester w/LED Display	Clam - Bargman
767941	4-Way Tester w/LED Display	Clam - Wesbar
767942	5-Way Tester w/LED Display and Dust Cap	Clam - Wesbar
51-767811	6-Way Tester w/LED Display	Clam - Bargman
54-767811	6-Way Tester w/LED Display	Bagged - Bargman
6562	7-Way Blade Tester and Trailer Emulator w/LED Display	Clam - Tekonsha
54-6562	7-Way Blade Tester and Trailer Emulator w/LED Display	Bagged - Bargman
767943	7-Way Blade Tester and Trailer Emulator w/LED Display	Clam - Wesbar
6565	Current Monitor	Bulk
8010	Trailer Tester, Includes Charger	Bulk
7585	Brake Control Bench Tester	Bulk

CIRCUIT TESTERS



Part No.	Description	Packaging
40376	Circuit Tester	Clam
3808	Economy Circuit Tester	Clam
20114	4-Flat Circuit Tester	Clam - Tow Ready
20115	5-Flat Circuit Tester	Clam - Tow Ready
20116	6-Way Circuit Tester	Clam - Tow Ready
20117	7-Way Circuit Tester	Clam - Tow Ready



40109
40110
6810
6811



01932-003
01933-003
01934-003
1935

01938-003
1936

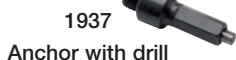

1937
Anchor with drill



58381

DRILL BITS & HOLE SAWS

Drill bits and hole saws are especially selected to best suit trailer hitch installations where drilling is required.

- Drill bits have 135° “split points” for easy starts on flat surfaces
- Made of high carbon, M-2 steel for maximum durability and minimum brittleness
- Bulk packaged

Part No.	Description	Overall Length	Flut Length
01932-003	3/8" Drill Bits (3 per poly bag)	5"	3-5/8"
01933-003	7/16" Drill Bits (3 per poly bag)	5-1/2"	4-1/16"
01934-003	1/2" Drill Bits (3 per poly bag)	6"	4-1/2"
1935	3/8", 7/16", 1/2" Drill Bits (1 set per poly bag)	—	—
1936	1" Hole Saw (1 per poly bag)		
1937	Hole Saw Arbor with pilot drill (1936) (1 per poly bag)		
58381	3-1/2" Hole Saw (1 per poly bag)	-	-
1124	Hole Saw Arbor with pilot drill (58381) (1 per poly bag)	—	—
01938-003	1/4" Pilot Drill Bit (3 per poly bag)	—	—
4655	9/16" Drill Bit with 1/2" shank (1 per poly bag)	6-1/8"	3"
40108	Replacement Pilot Bits for Rotabroach cutting tools	—	—
40109	3/8" Rotabroach hole cutting tool with pilot (1 per plastic tube)	—	—
40110	7/16" Rotabroach hole cutting tool with pilot (1 per plastic tube)	—	—
6810	1/2" Rotabroach hole cutting tool with pilot (1 per plastic tube)	—	—
6811	9/16" Rotabroach hole cutting tool with pilot (1 per plastic tube)	—	—

LOAD-MASTER TRAILER TONGUE WEIGHT SCALE

Load-Master is a hydraulic pressure gauge for measuring trailer tongue weights from 0 to 2,000 lbs.



5780

Part No.	Description
5780	Load-Master Trailer Tongue Weight Scale



11748

HITCH BALL GREASE

Part No.	Description
11748	Hitch Ball Grease, 4 oz. tube

WIRE LOOMS



5481
5482
55393

Part No.	Description
5481	7/16" Wire Forms (20 pack)
5482	1/2" Wire Forms (20 pack)
55393	3/8" Wire Forms (1 pack)

PRODUCT DISPLAYS

- Hitch Displays
- Weight Distributing Displays
- Fifth Wheel Displays
- Pin Box Displays
- Gooseneck Hitch Displays
- Jack Displays
- Brake Control Displays
- ToyLok® Display
- Mini Light Display
- Bike / Cargo Carrier Displays
- Product Displays - Suggested Product Listing
- Gondola Displays
- Gondola Shelf and Hitch Ball / Ball Mount Racks

HEADER SIGNS/CARDS / GONDOLA WALLPAPER

- Gondola Wallpaper
- Header Cards / Signs

MERCHANDISING MATERIALS

- Display Out of Stock Tags
- Counter Mats
- Poster
- Banners
- Window Clings
- Outdoor Signs / Mounting Systems
- Showroom Signs
- Literature Holders
- Show Bags
- Catalogs / Clip Art Disks
- Product DVDs

PLANOGRAM LAYOUTS

- Jack Products – Suggested Layout
- Jack / Coupler Products – Suggested Layout
- Towing Products / Accessories – Suggested Layouts
- Wiring Products / Accessories - Suggested Layout
- Lighting Products – Suggested Layouts
- Lighting / Wiring Products – Suggested Layout
- Cargo Management Products – Suggested Layouts

There may be charges for display items. Contact your sales representative for ordering information.

HITCH DISPLAYS

Hitch Display Racks promote the products you install. Turn your hitch display into an add-on sales tool by attaching the Accessory Display Kit. It is designed to help promote the sale of hitch balls, tow vehicle wiring and other towing accessories.

PRODUCT MUST BE ORDERED SEPARATELY



PRODUCT MUST BE ORDERED SEPARATELY

Part No.	Description
37-0030	5-Hitch, 4-Ball Mount Display w/Flip Chart Attachment
37-5637	2-Hitch Display w/Pegboard
37-5638	4-Hitch Display
MKG0221	Draw-Tite® Flip Chart for Hitch Display 37-0030
MKG0249	Hidden Hitch® Flip Chart for Hitch Display 37-0030
MKG0163	Reese® Flip Chart for Hitch Display 37-0030
1592	Hitch Display, Hitch Hook (included with displays)

Note: See HEADER CARDS / SIGNS for hitch display graphics.



MKG0221



MKG0249



MKG0163

WEIGHT DISTRIBUTING DISPLAY

Great for showroom display of weight-distributing hitches.

PRODUCT MUST BE ORDERED SEPARATELY

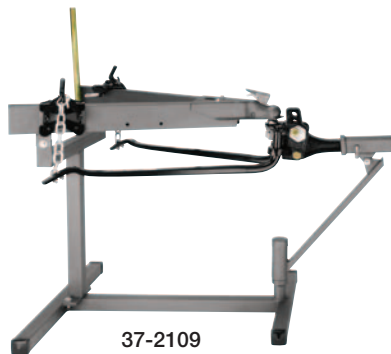

PRODUCT MUST BE ORDERED SEPARATELY

Part No.	Description
37-2109	Weight Distributing Stand (2-5/16" coupler) – 2" receiver tube built-in (2-5/16" ball not included)

There may be charges for display items. Contact your sales representative for ordering information.

FIFTH WHEEL DISPLAYS

Fifth wheel hitch displays promote the products you install. Stand will display from one to three fifth wheel hitch heads. 37-2123 and 37-2103 include attachment for display signage.



37-2123
(Display only)

37-2129 - Pro Series Display
INCLUDES: Signage, Brochures

PRODUCT MUST BE ORDERED SEPARATELY

Part No.	Description
37-2123	Tier Design Fifth Wheel Hitch Display only – mount up to three Pro Series™ fifth wheel hitch heads
37-2129	Tier Design Fifth Wheel Hitch Display (includes Pro Series signage and brochures)
37-2103	Heavy Duty Fifth Wheel Hitch Display – mount one fifth wheel hitch head (37-2103 includes sign attachment brackets, order signage separately)
37-0209	Fifth Wheel Display Legs (requires mounting kit 30035 or 30095)
MKG0218	Draw-Tite® logo sign for 37-2103
MKG0346	Reese® logo sign for 37-2103
MKG0245	Hidden Hitch® logo sign for 37-2103
MKG0255	Reese® Elite™ Series merchandising sign for 37-2103



37-2103

PRODUCT MUST BE ORDERED SEPARATELY



MKG0255

MKG0218 (DT)
MKG0346 (RS)
MKG0245 (HH)

37-2103

PRODUCT MUST BE ORDERED SEPARATELY

PIN BOX DISPLAYS

Fifth wheel trailer pin box displays promote the pin boxes you install. Stand will display one of the custom pin boxes. Reese 16K head, signage and brochures are included with display.

Part No.	Description
37-2130	Reese® Pin Box Display (includes Reese 16K head, signage and brochures)



Shown with Sidewinder™

37-2130
(Display only)

PRODUCT MUST BE ORDERED SEPARATELY



Shown with 5th Airborne™

37-2130
(Display only)

PRODUCT MUST BE ORDERED SEPARATELY

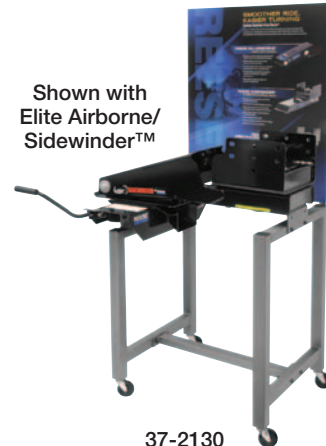

Shown with Elite Airborne/
Sidewinder™

37-2130
(Display only)

PRODUCT MUST BE ORDERED SEPARATELY

There may be charges for display items. Contact your sales representative for ordering information.



37-2118
Draw-Tite®

PRODUCT MUST BE ORDERED SEPARATELY

GOOSENECK HITCH DISPLAYS

Gooseneck displays promote the gooseneck trailer towing systems you install. Stand will display hitch system and platform heads.

PRODUCT MUST BE ORDERED SEPARATELY

Part No.	Description
37-2118*	Draw-Tite® Hide-A-Goose™ System Display (includes signage and brochures)
37-2122*	Bulldog® Under-Bed System Display (includes signage and brochures)
116437	Draw-Tite® Signage
116438	Bulldog® Signage

**NOTE: Displays Under-Bed Gooseneck, Remov-A-Ball® and Fold-Down Gooseneck Hitches*



37-2122
Bulldog®

JACK DISPLAYS

Display stands increase end-user visibility to Jacks, Winches, and Couplers. Using a minimal amount of floor space these stands provide easy access to all products displayed.

PRODUCT MUST BE ORDERED SEPARATELY



600051

PRODUCT MUST BE ORDERED SEPARATELY

Part No.	Description
600051	Display Stand – Jacks, Includes: Integrated Center A-Frame Mount, (4) A-Frame Jack Display Adapters
37-2125	Display Stand – Marine Jacks, Includes(3) Jack Display Adapters #117399, (1) Fold-Away™ Coupler
37-2126	Display Stand – RV Jacks, Includes (4) Jack Display Adapters #117400
117398	Jack Display Stand
117399	Marine Jack Display End Caps – Jack Adapter Only
117400	RV Jack Display End Caps – Jack Adapter Only



37-2125
(Includes Marine Jack Adaptors & HPB35030101)



117398 (Display Only)
37-2126 (Includes RV Jack Adaptors)

There may be charges for display items. Contact your sales representative for ordering information.

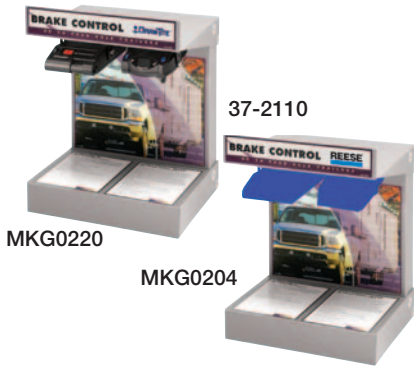

COUNTER TOP BRAKE CONTROL DISPLAYS

Counter top brake control displays with interchangeable insert cards. Cards are easily removed to change display as often as needed. Insert cards sold separately. *PRODUCT MUST BE ORDERED SEPARATELY*

Part No.	Description
37-2110	Brake Control Counter Top Display Only
MKG0220	Draw-Tite® Brake Control Features & Benefits Insert Cards
MKG0204	Reese® Brake Control Features & Benefits Insert Cards
37-2115	Draw-Tite® Brake Control Counter Top Display w/Activator® III Graphic Package
37-2116	Reese® Brake Control Counter Top Display w/Brakeman® Ultra Graphic Package



TOYLOK® DISPLAY

Counter top display includes TL2021 15' ToyLok retractable cable lock. Attached flip chart showing all available mounting accessories. Includes heavy duty velcro to secure display.

Part No.	Description
37-2124	ToyLok® Display



MINI LIGHT DISPLAY

Light display mounts to gondola using peg hooks. Includes incandescent and LED tail lights, clearance lights, and AMP meter to show the draw of each type of light. No internal power source, includes 6' wiring for battery use. 20" L x 9" H x 5" D

Part No.	Description
37-2048	Bargman® Mini Light Display includes Lights & AMP Meter
37-2049	Wesbar® Mini Light Display includes Lights and AMP Meter



37-2046
PRODUCT MUST BE ORDERED SEPARATELY

BIKE / CARGO CARRIER DISPLAYS

Hitches aren't just for towing any longer. From bike and cargo carriers to the wide range of front mounted receiver accessories, these displays illustrate all the options available to your customer with the purchase of their new receiver. Load up the carriers in your showroom to illustrate the features and benefits of these great hitch mounted accessories.

PRODUCT MUST BE ORDERED SEPARATELY

Part No.	Description
37-2046	4-Bike Carrier Display
37-6297	2-Cargo/Bike Carrier Display
37-6475	Roof Top Carrier Display for use with 37-6297
MKG0254	ROLA® Sign for use with 37-6475, 9" x 34"
MKG0239	ROLA® Sign for use with 37-6297, 9" x 34"
MKG0240	ROLA® Sign for use with 37-6297, 9" x 34"



MKG0240

There may be charges for display items. Contact your sales representative for ordering information.

HITCH DISPLAYS - SUGGESTED PRODUCTS - PRODUCT MUST BE ORDERED SEPARATELY

Display Part No.	Brand.	Description
37-0030	Draw-Tite®	24759, 36303, 75193, 41921, 45288
	Hidden Hitch® / Reese®	60818, 87006, 33036, 44028, 45288
	Pro Series™	51162, 51102, 51001, 51072, 45288

WEIGHT DISTRIBUTING DISPLAYS - SUGGESTED PRODUCTS - PRODUCT MUST BE ORDERED SEPARATELY

Display Part No.	Brand.	Description
37-2109	Reese® Trunnion WD	66540 or 66541 or 66542, 63831
	Reese® Round Bar WD	65509 or 67509 or 61009, 63831
	Reese® SC	66151 or 66153 or 66155 or 66157, 63831
	Reese® Dual Cam	26002
	Reese® Friction Sway Control	26660
	Reese® Strait Line® Trunnion	66082 or 66083 or 66084, 63831
	Reese® Strait Line® Round Bar	66086 or 66087 or 66088, 63831
	Draw-Tite® Trunnion WD	7901 or 7902 or 7903 + 54970 shank
	Draw-Tite® Round Bar WD	3201 or 3202 or 3230 + 54970 shank
	Draw-Tite® Dual Cam	26102
	Draw-Tite® Friction Sway Control	3400
	Pro Series™ Complete	49901 or 49902 or 49903 (includes 2-5/16" hitch ball)
	Pro Series™ Trunnion WD	49585 or 49586 or 49587
	Pro Series™ Round Bar WD (RB2)	49568 or 49569 or 49570
	Optional Pro Series™ Sway Control	83660

TIERED FIFTH WHEEL DISPLAYS - SUGGESTED PRODUCTS - PRODUCT MUST BE ORDERED SEPARATELY

Display Part No.	Brand.	Description
37-2129*	Pro Series™	30099, 30098, 30118 (heads only)
37-2123	Pro Series™	30099, 30098, 30118 (heads only)

*NOTE: Includes signage and brochures.

FIFTH WHEEL DISPLAYS - SUGGESTED PRODUCTS - PRODUCT MUST BE ORDERED SEPARATELY

Display Part No.	Brand.	Description
37-2103	Reese® Elite™ Fifth Wheel	30065 or 30142 or 30143
	Reese® Elite™ Fifth Wheel w/Slider	30144
	Reese® Fifth Wheel	30047 or 30054 or 30033 or 30081 or 30083 or 30084
	Draw-Tite® Fifth Wheel	6021 or 6032
Rails and Mounting Bracket Required for Mounting Hitch to Display Description		
	Reese® Elite™ Fifth Wheel Rail	30126 (Ford) or 30868 (GM)
	Fifth Wheel Rail Kit	30035
	Fifth Wheel Mounting Bracket	50081

GOOSENECK HITCH DISPLAYS - SUGGESTED PRODUCTS - PRODUCT MUST BE ORDERED SEPARATELY

Display Part No.	Brand.	Description
37-2122*	BullDog®	9471-37, 630044, 8339
37-2118*	Draw-Tite®	9461-37, 6300, 8339

*NOTE: Includes signage and brochures.

PIN BOX DISPLAYS - SUGGESTED PRODUCTS - PRODUCT MUST BE ORDERED SEPARATELY

Display Part No.	Brand.	Description
37-2130*	Reese®	61420 (Sidewinder™)
	Reese®	5AB-E1621-16K (5th Airborne™)
	Reese® Elite™	61422 (Airborne/Sidewinder™ Combo)

*NOTE: Includes signage and brochures.

There may be charges for display items. Contact your sales representative for ordering information.



37-5365

GONDOLA DISPLAYS

No matter the showroom size, these displays offer the ultimate return on display space. Placed against a wall or as an island, gondola displays offer your customers a complete line of towing and vehicle accessories.

PRODUCT MUST BE ORDERED SEPARATELY

Part No.	Description
37-5365	4' Tall x 4' Lozier Gondola
37-5366	4' Tall x 4' Lozier Island Gondola (two sided)
37-5367	4' Tall x 2' Lozier Gondola
37-2128	7' Tall x 4' Lozier Gondola
37-2112	Rack 4' - Ball Mount for Lozier Gondola
37-2114	Rack 4' - Hitch Ball for Lozier Gondola
37-2127	Rack 4' - One Half Hitch Ball / One Half Ball Mount for Lozier Gondola
37-2134	A-Frame Jack Mount System for Lozier Gondola - includes (1) 37-2131 Crossbar, (5) 37-2132 Brackets, (1) 37-2133 Bracket Support
37-2131	Crossbar 4' for Lozier Gondola (mount up to 5 brackets, 37-2132)
37-2132	Bracket (each) - A-Frame Jack Mounting on 37-2131 Crossbar (mount up to 3 jacks / ea bracket)
37-2133	Bracket Support 4' (each) - A-Frame Jack Mounting on 37-2131 Crossbar (use w/37-2132)
37-6666	Shelf 4' for Lozier Gondola
37-2082	Pegboard 4" Hook, 50 pcs.
37-2078	Pegboard 6" Hook, 50 pcs.
37-2081	Pegboard 8" Hook, 50 pcs.



MKG0232

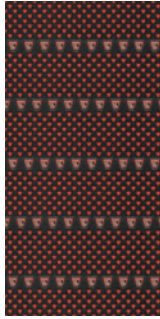

MKG0210



MKG0255



MKG0191

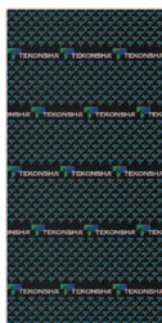

MKG0187



MKG0230

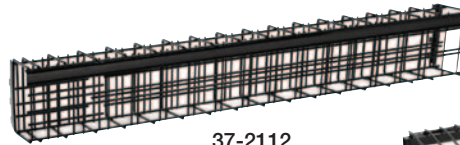

37-2112

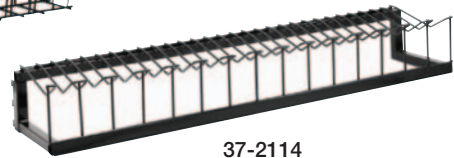

37-2114

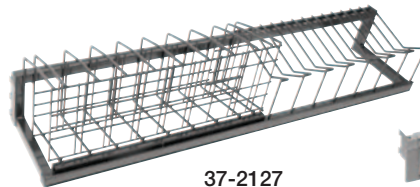

37-2127



37-2134

GONDOLA WALLPAPER

Ideal for drawing attention to gondolas displaying products. Wallpaper is 2'x4' and ideal for covering multiple colored pegboards on the display floor. Wallpaper is heavy-duty vinyl, pre-perforated for peg hooks and includes mounting pins to attached to peg board.

GONDOLA WALLPAPER, 2' X 4'

Part No.	Description
MKG0232	Bargman® Logo Design
MKG0210	Bulldog® Logo Design
MKG0225	Draw-Tite® Logo Design
MKG0191	Fulton® Logo Design
MKG0187	Tekonsha® Logo Design
MKG0230	Wesbar® Logo Design

There may be charges for display items. Contact your sales representative for ordering information.



MKG0233 MKG0234



MKG0211 MKG0212



MKG0209



MKG0218



MKG0197 MKG0217



MKG0192 MKG0193



MKG0243 MKG0244



MKG0245



MKG0253
MKG0258 (French)

HEADER CARDS / SIGNS

Merchandising headers in a wide range of sizes for use on displays or any show-room application.

Part No.	Description	
MKG0233	Bargman® Logo Merchandising Sign	6" x 24"
MKG0234	Bargman® Logo Merchandising Sign	6" x 48"
MKG0209	Bulldog® Merchandising Sign	14" x 48"
MKG0211	Bulldog® Logo Merchandising Sign	6" x 24"
MKG0212	Bulldog® Logo Merchandising Sign	6" x 48"
MKG0218	Draw-Tite® Logo and Website Merchandising Sign	10" x 41-1/2"
MKG0219	Draw-Tite® Hitch Classification Merchandising Sign	12" x 42"
MKG0217	Draw-Tite® & Tow Ready® Merchandising Sign	9" x 16"
MKG0197	Draw-Tite® & Tow Ready® Merchandising Sign	14" x 42"
MKG0192	Fulton® Logo Merchandising Sign	6" x 24"
MKG0193	Fulton® Logo Merchandising Sign	6" x 48"
MKG0245	Hidden Hitch® Logo and Website Merchandising Sign	10" x 41-1/2"
MKG0246	Hidden Hitch® Classification Merchandising Sign	12" x 42"
MKG0244	Hidden Hitch® & Tow Ready® Merchandising Sign	9" x 16"
MKG0243	Hidden Hitch® & Tow Ready® Merchandising Sign	14" x 42"
MKG0253	Pro Series™ Merchandising Sign	27" x 27"
MKG0258	Pro Series™ Merchandising Sign (French)	27" x 27"
MKG0346	Reese® Logo and Website Merchandising Sign	10" x 41-1/2"
MKG0205	Reese® Hitch Classification Merchandising Sign	12" x 42"
MKG0182	Reese® Merchandising Sign	15" x 39"
MKG0201	Reese® & Tow Ready® Merchandising Sign, 2-sided	9" x 16"
MKG0200	Reese® & Tow Ready® Merchandising Sign	14" x 42"
MKG0237	ROLA® Merchandising Sign	9" x 16"
MKG0254	ROLA® Cargo Basket and Carrier Merchandising Sign	9" x 34"
MKG0239	ROLA® Cargo Basket/Adventure Merchandising Sign	9" x 34"
MKG0240	ROLA® Pursuit/Adventure Merchandising Sign	9" x 34"
MKG0236	ROLA® Merchandising Sign	14" x 42"
MKG0188	Tekonsha® Logo Merchandising Sign	6" x 24"
MKG0189	Tekonsha® Logo Merchandising Sign	6" x 48"
MKG0185	Tow Ready® Merchandising Sign	3" x 24"
MKG0186	Tow Ready® Merchandising Sign	8" x 24"
MKG0231	Wesbar® Logo Merchandising Sign	6" x 24"
MKG0235	Wesbar® Logo Merchandising Sign	6" x 48"



MKG0182



MKG0200 MKG0201



MKG0236 MKG0237



MKG0240



MKG0188 MKG0189



MKG0231 MKG0235

There may be charges for display items. Contact your sales representative for ordering information.

DISPLAY – OUT OF STOCK TAGS

Part No.	Description
MKG0269	Draw-Tite® “Out of Stock” Tags, 50 pcs.
MKG0289	Hidden Hitch® “Out of Stock” Tags, 50 pcs.
MKG0271	Reese® “Out of Stock” Tags, 50 pcs.
MKG0262	Tow Ready® “Out of Stock” Tags, 50 pcs.



MKG0214



MKG0224



MKG0190



MKG0226

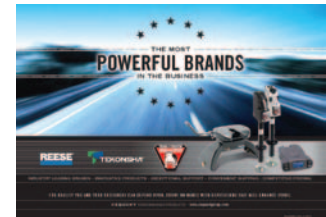

MKG0257



MKG0206

POSTER

Part No.	Description
MKG0206	“Why Buy Reese” Poster (24 x 36)

BANNERS

Attract potential customs with branded durable, indoor/outdoor banners.

Part No.	Description
MKG0241	Hidden Hitch®, 6' x 3' w/six grommets
MKG0248	Hidden Hitch® (French), 6' x 3' w/six grommets
MKG0196	Draw-Tite® “Tested Tough”, 5' x 3' w/four grommets
MKG0227	Draw-Tite® “Tested Tough” (French), w/four grommets
MKG0238	ROLA®, 6' x 21" w/six grommets
MKG0202	Reese®, 6' x 21" w/six grommets
MKG0183	Tow Ready®, 6' x 21" w/six grommets



MKG0196
MKG0227 (French)



MKG0241
MKG0248 (French)



MKG0202

There may be charges for display items. Contact your sales representative for ordering information.



MKG0250
MKG0247 (French)



MKG0223

WINDOW CLINGS

Part No.	Description
MKG0213	Bulldog® Window Cling "Gooseneck Hitches", 6"x4", two sided
MKG0223	Draw-Tite® Window Cling "Hide-A-Goose™ Hitch", 4"x6", two sided
MKG0250	Hidden Hitch® Window Cling "We Install Quality Trailer Hitches", 6"x8"
MKG0247	Hidden Hitch® Window Cling "We Install Quality Trailer Hitches" (French), 6"x8"
MKG0195	Draw-Tite® Window Cling "Trailer Hitches", 8-1/2" x 11", single sided



MKG0195



MKG0213

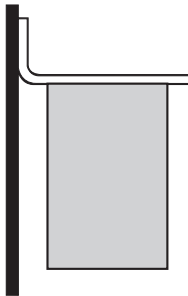

2859

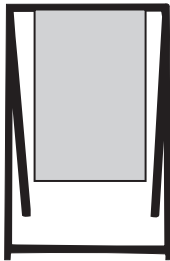

2860

OUTDOOR SIGNS

Outdoor metal signs with two different mounting systems. Purchase separately a sign and then either the curb side mounting stand or the wall/pole mounting bracket.

Durable metal bracket for either wall or pole mounting includes hardware for installation.

Part No.	Description
2859	Wall or pole mounting bracket only

Curb side A-Frame stand folds flat for easy storage. When opened the base has an extra wide stance for safe and secure setup.

Part No.	Description
2860	Curb stand only

Outdoor metal signs

Part No.	Description
2858	Draw-Tite® aluminum sign only, 24"w x 30"h
37-2051	Hidden Hitch® aluminum sign only, 24" x 30"h
37-5652	Reese® aluminum sign only, 24"w x 30"h



37-2051



37-5652



2858

There may be charges for display items. Contact your sales representative for ordering information.

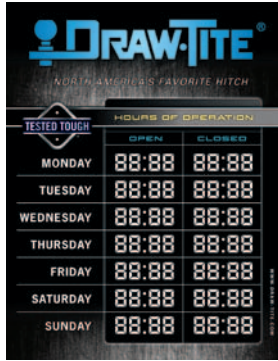

MKG0216

SHOWROOM SIGNS HOURS OF OPERATION

Part No.	Description
MKG0198	Reese® Hours of Operation Indoor Sign
MKG0216	Draw-Tite® Hours of Operation Indoor Sign
MKG0252	Hidden Hitch® Hours of Operation Indoor Sign



MKG0252



MKG0251

LITERATURE HOLDER

Part No.	Description
MKG0251	Single Literature Holder

SHOW BAGS

Part No.	Description
MKG0208	Reese® branded show bag, 15"x12"w
MKG0215	Draw-Tite® branded show bag, 15"x12"w
MKG0242	Hidden Hitch® branded show bag, 15"x12"w



MKG0208



MKG0215



MKG0242

There may be charges for display items. Contact your sales representative for ordering information.

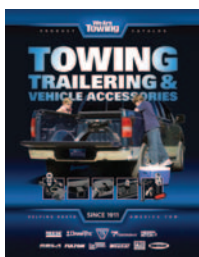

98929-2012

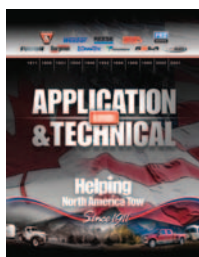

98931-2012

CATALOGS

Part No.	Description
98929-2012	Catalog - Towing, Trailering & Vehicle Accessories
98931-2012	Application/Technical Catalog - Towing, Trailering & Vehicle Accessories



CLIP ART DISKS

Clip art files are available on DVD as high resolution (300 dpi, CMYK) files. Compatible with PC and Mac operating systems.

Part No.	Description
MKG0535	Clip Art Disk - Towing, Trailering & Vehicle Accessories CATALOG
MKG0536	Clip Art Disk - Towing, Trailering & Vehicle Accessories APPLICATION GUIDE

PRODUCT DVDS

Product instructional and informational videos.



MKG0160

WEIGHT DISTRIBUTION FIFTH WHEEL HITCHES

Part No.	Description
MKG0162	DVD – Reese® “Discover Weight Distribution”
MKG0207	DVD – Reese® “Fifth Wheel Hitches”



MKG0158



MKG0156

PROPORTIONAL BRAKE CONTROLS

Part No.	Description
MKG0164	DVD - Draw-Tite® I-Stop™ IQ
MKG0161	DVD - Tekonsha® Prodigy® RF
MKG0160	DVD - Tekonsha® P3®
MKG0158	DVD - Tekonsha® Prodigy® P2
MKG0159	DVD - Tekonsha® Primus™ IQ
MKG0156	DVD - Tekonsha® Voyager®

There may be charges for display items. Contact your sales representative for ordering information.



BULLDOG® JACK PLANOGRAM

Recommending a complete layout of the best selling BULLDOG jack products.

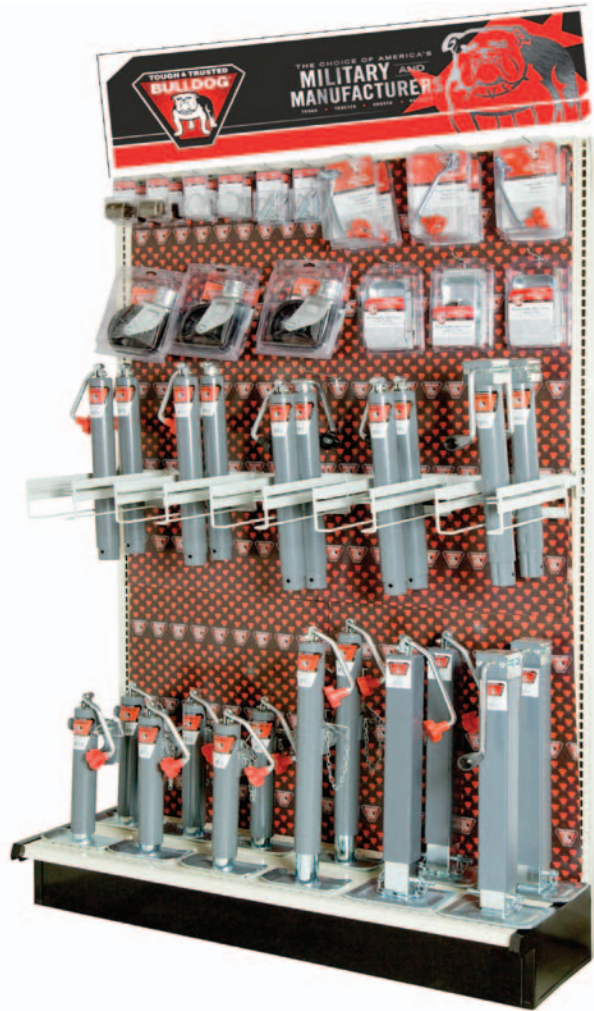

Ref. No.	Part No.	Brand	Description	Qty
1	500239	BULLDOG	Replacement Part, Swivel Trailer Mount, Tubular Male Weld-On For 9/16 Pull Pin, for 2000 lbs. Jacks & 5000 lbs. Topwind Jack Only	4
2	500241	BULLDOG	Replacement Part, Swivel Retaining Ring For 800-5000 lbs. Jacks	4
3	500243	BULLDOG	Replacement Part, 9/16 Pull Pin w/12-1/4 Chain & Drive Screw For 2000 lbs. Jacks & 5000 lbs. Topwind Jack Only	4
4	500180	BULLDOG	Replacement Part, Topwind Crank, 6-3/4 Radius w/Red Bulldog Knob For 750-5000 lbs. Jacks	6
5	500245	BULLDOG	Tongue Jack Caster w/6 Wheel & Pin/Clip, for 2000-5000 lbs. Jacks	3
6	500244	BULLDOG	Replacement Part, Removable Disc Foot, 2-3/32 Tall w/ Snapper Pin for 2000-5000 lbs. Jacks	3
7	155022	BULLDOG	A-Frame Jack, Topwind, 15 Travel, 8.4 Bracket to Ground Retracted, Weld-On/Bolt-On, 2,000 lbs. Lift Capacity	4
8	155032	BULLDOG	A-Frame Jack, Topwind, 15 Travel, 10.15 Bracket to Ground Retracted, Weld-On/Bolt-On, 5,000 lbs. Lift Capacity	4
9	155157	BULLDOG	A-Frame Jack, Sidewind, 13 Travel, 8.6 Bracket to Ground Retracted, Weld-On/Bolt-On, 2,000 lbs. Lift Capacity	2
10	151401	BULLDOG	Weld-On Jack, Topwind, 10 Travel, Weld-On "L" Bend Swivel Bracket, 2,000 lbs. Lift Capacity (Includes Base)	2
11	158451	BULLDOG	Swivel Jack, Topwind, 10 Travel, Weld-On Tubular Mount, 2,000 lbs. Lift Capacity (Includes Foot Plate)	2

Ref. No.	Part No.	Brand	Description	Qty
12	178101	BULLDOG	Swivel Jack, Topwind, 10 Travel, Weld-On Tubular Mount, 5,000 lbs. Lift Capacity (Includes Foot Plate)	2
13	158452	BULLDOG	Swivel Jack, Topwind, 15 Travel, Weld-On Tubular Mount, 2,000 lbs. Lift Capacity (Includes Foot Plate)	2
14	190704	BULLDOG	TWL 190 DL-BQ, 8,000 lbs. Support Cap., 15 Travel, Drop Leg, No Mount	2
15	190754	BULLDOG	SWL 190 DL-BQ, 8,000 lbs. Support Cap., 15 Travel, Drop Leg, No Mount	2
TOTAL CONTENTS				46
	37-2128		7' Tall x 4' Lozier Gondola	1
	37-2134		A-Frame Jack Mount System for Lozier Gondola - includes (1) 37-2131 Crossbar, (5) 37-2132 Brackets, (1) 37-2133 Bracket Support	1
	37-2078		Pegboard 6" Hook, 50 pcs.	1
	MKG0209		BULLDOG® Header Card	1
	MKG0210		BULLDOG® Gondola Wallpaper	4

*NOTE: See GONDOLA DISPLAYS for gondola accessory items.



BULLDOG® JACK PLANOGRAM

Cequent Performance Products Merchandising Solutions

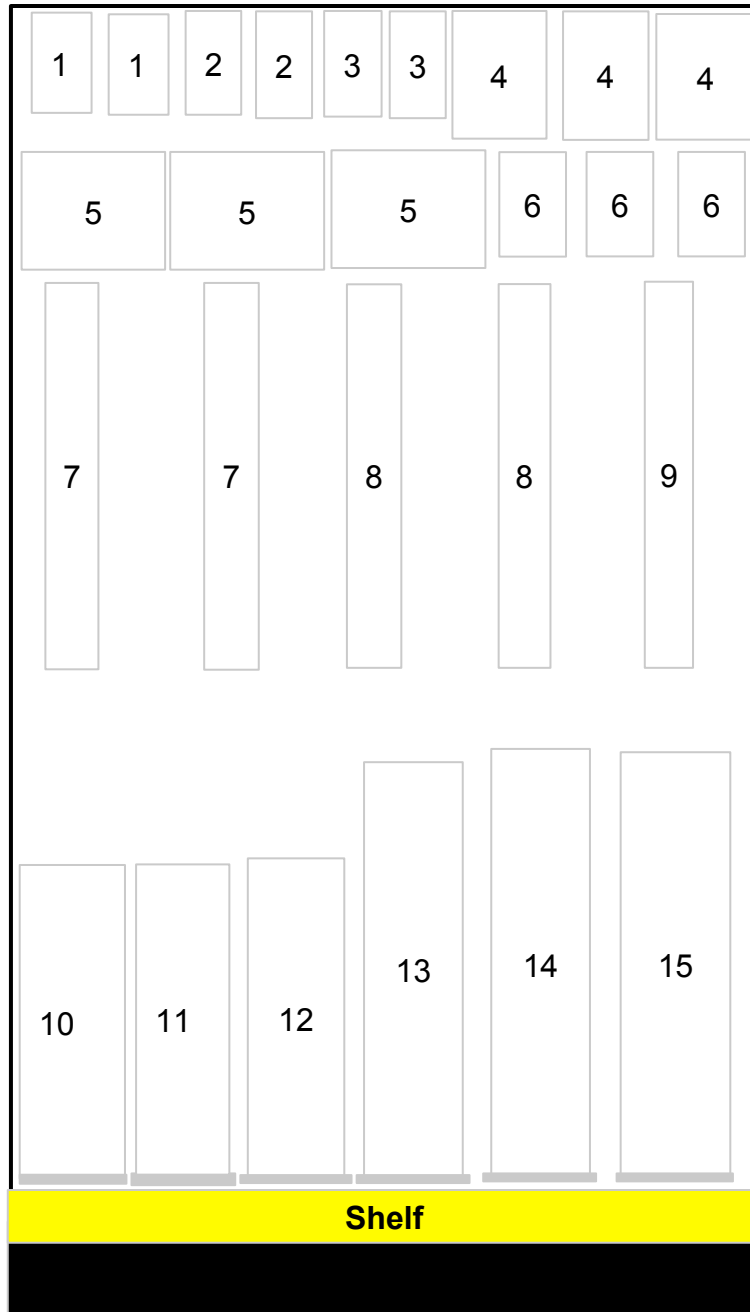



FULTON® COUPLER / PRO SERIES™ JACK PLANOGRAM



Recommending a complete layout of the best selling Pro Series jack and Fulton coupler products.



Ref. No.	Part No.	Brand	Description	Qty
1	11200 0101	Fulton	Coupler, Class I, 1-7/8" Ball, 2" Channel, 2000 lbs. - Zinc	2
2	11300 0101	Fulton	Coupler, Class I, 1-7/8" Ball, 3" Channel, 2000 lbs. - Zinc	2
3	22200 0101	Fulton	Coupler, Ball Size 2", 2" Tongue Mount Width, Straight Channel, Zinc Finish, Rating 3,500 lbs.	2
4	22250 0101	Fulton	Coupler, Ball Size 2", 2-1/2" Tongue Mount Width, Straight Channel, Zinc Finish, Rating 3,500 lbs.	2
5	22300 0101	Fulton	Coupler, Ball Size 2", 3" Tongue Mount Width, Straight Channel, Zinc Finish, Rating 3,500 lbs.	2
7	1400700340	Pro Series	Pro Series Foot Plate & Pin	2
9	EA20000303	Pro Series	2000 lbs., TW, A-Frame, 14 Travel, Black	4
10	A256S 0303	Pro Series	Adjustable Coupler, Cast Head, w/Hardware, Less Channel, 14,000 lbs. - Black	1
11	RV20000303	Pro Series	2000 lbs., SW, A-Frame, 14 Travel, Black	2
12	AC500 0300	Pro Series	6 Hole, 5 Position Channel, w/11-3/4" Height	1
13	1400600303	Pro Series	Pro Series™ A-Frame Jack, 5,000 lbs.	4
14	1400850383	Pro Series	Pro Series™ Square Tube, 8,000 lbs., Sidewind, 15 Travel, Adjustable Dropleg w/Additional Travel of 13.6	2

Ref. No.	Part No.	Brand	Description	Qty
15	1400800383	Pro Series	Pro Series™ Square Tube, 8,000 lbs., Topwind, 15 Travel, Adjustable Dropleg w/Additional Travel of 13.6	2
16	1401200303	Pro Series	Pro Series™ Weld-On Jack, Topwind, 2,000 lbs. w/ Footplate	2
17	1401460303	Pro Series	Pro Series™ Weld-On Jack, Topwind, 5,000 lbs.	2
18	1400400303	Pro Series	Pro Series™ Weld-On Jack, Topwind, 10 Travel, 2,000 lbs. w/Footplate	2
19	1401140303	Pro Series	Pro Series™ Weld-On Jack, Topwind, 2,000 lbs. w/ Footplate	2
TOTAL CONTENTS				36
	37-2128		7' Tall x 4' Lozier Gondola	1
	37-2134		A-Frame Jack Mount System for Lozier Gondola - includes (1) 37-2131 Crossbar, (5) 37-2132 Brackets, (1) 37-2133 Bracket Support	1
	37-2078		Pegboard 6" Hook, 50 pcs.	1

*NOTE: See GONDOLA DISPLAYS for gondola accessory items.

MERCHANDISING



FULTON® COUPLER / PRO SERIES™ JACK PLANOGRAM

Cequent Performance Products Merchandising Solutions

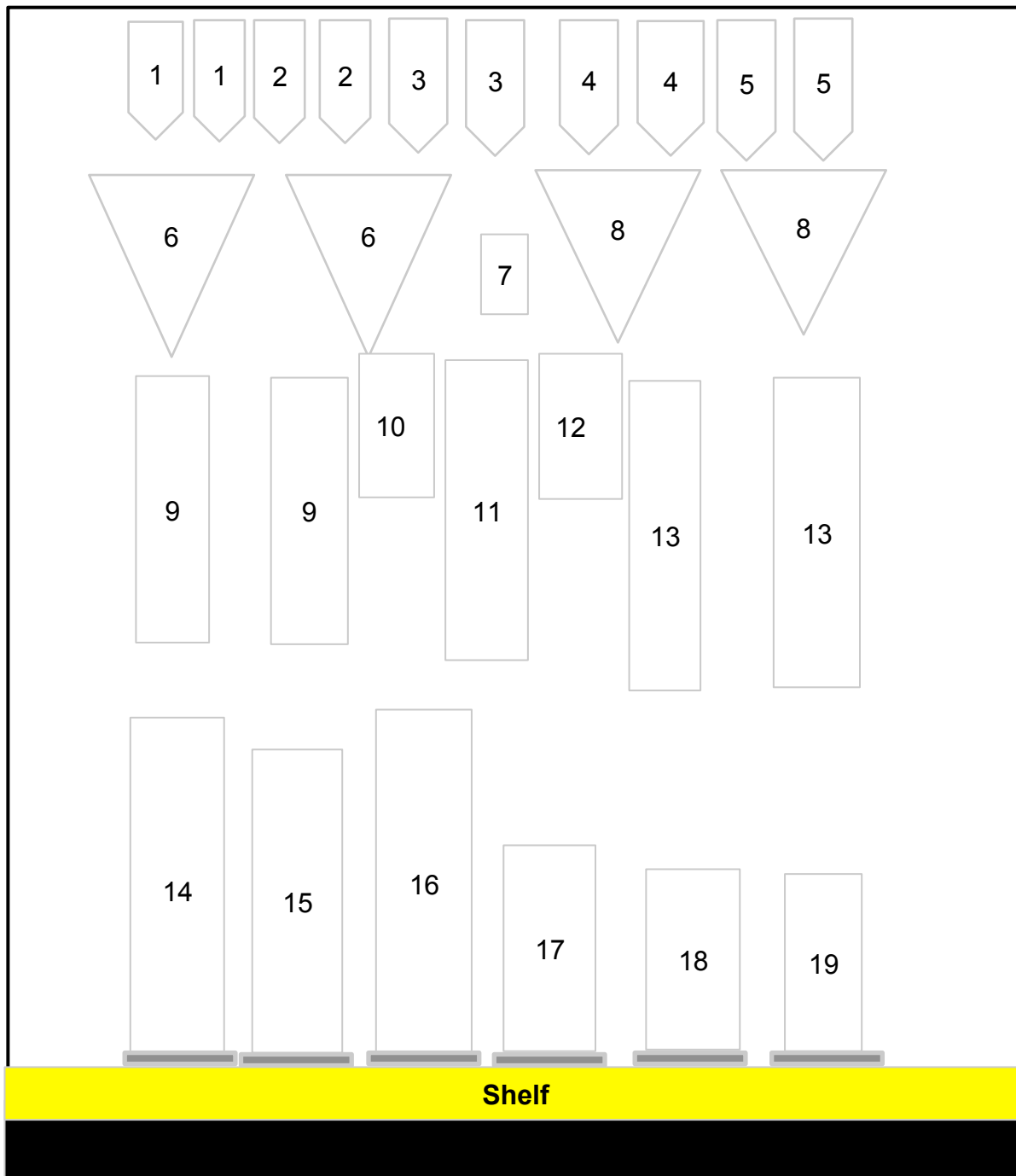



DRAW-TITE® / TOW READY® PLANOGRAM



Recommending a complete layout of the best selling Draw-Tite / Tow Ready towing products and accessories.



Ref. No.	Part No.	Brand	Description	Qty
ELECTRICAL ITEMS				
1	118702	TowReady	7-Way Flat Pin to 4-Flat Adapter	2
2	118021	TowReady	7-Way Flat Pin Connector, Trailer End, Plastic	2
3	118703	TowReady	7-Way Flat Pin to 5-Flat Adapter	2
4	118704	TowReady	7-Way Flat Pin to 6-Way Round Adapter w/Electric Brakes to Outside (S) Pin of 6-Way	2
5	118708	TowReady	7-Way Flat Pin to 6-Way Round Adapter w/Electric Brakes to Center (A) Pin of 6-Way	2
6	20112	TowReady	Cover, 4-Flat LED Connector	2
13	118020	TowReady	7-Way Flat Pin Connector, Car End, Plastic	2
14	118702	TowReady	6-Way Round Pin to 4-Flat Adapter	2
15	20047	TowReady	7-Way U.S. Car Replacement Socket for 7-Way Twist In OEM GM Vehicles	2
16	20321	TowReady	4-Flat to 7-Way Flat Pin Connector Adapter, Plastic	2
17	118138	TowReady	Mounting Bracket for 7-Way Flat Pin Connectors, Includes Screws and Nuts	2
18	118136	TowReady	Universal Mounting Bracket and Clamp (Long)	2
19	118144	TowReady	4-Flat Mounting Bracket	2

Ref. No.	Part No.	Brand	Description	Qty
24	118004	TowReady	4-Flat Trailer End Connector, 12" Long	2
25	118185	TowReady	4-Flat Plug Loop, 18" Long (Includes 4 Wire Taps)	2
26	118045	TowReady	4-Flat Plug Loop, 60" Long (Includes 4 Wire Taps)	2
27	118001	TowReady	4-Flat Car End Connector 48" Long (Includes 4 Wire Taps)	2
28	118033	TowReady	4-Flat Trailer End Connector, 48" Long	2
29	20144	TowReady	7-Way Flat Pin Connector/4-Flat Combo Adapter Harness w/Mounting Bracket & Hardware	2
30	118159	TowReady	6 & 7-Way Connector Mounting Box, Universal for Round & Square Tube Hitches	2
HITCH BALLS				
36	63810	TowReady	Bulk Ball 1.875X.75X1.5	5
37	63816	TowReady	Bulk Ball 1.875X1X2.125	5
38	63820	TowReady	Bulk Ball 2X.75X1.50	5
39	63822	TowReady	Bulk Ball 2X.75X2.375	5
40	63826	TowReady	Bulk Ball 2X1X2.125	5
41	63828	TowReady	Bulk Ball 2X1X3.375	5
42	63830	TowReady	Bulk Ball 2X1.25X2.75	4



Ref. No.	Part No.	Brand	Description	Qty	Ref. No.	Part No.	Brand	Description	Qty
DRAW BARS/BALLMOUNTS & LOCKS									
7	63204	TowReady	1/2" Integral Pin & Clip for 1-1/4" Sq. Receivers - Zinc	3	50	40346	Draw-Tite	Quick-Loading Ball Mount, 6,000 lbs. GTW, 1" Ball Hole, 9-1/2" Length, 4-3/4" Rise, 6" Drop, Black	1
8	63205	TowReady	5/8" Integral Pin & Clip for 2" Sq. Receivers - Zinc	3	51	40330	Draw-Tite	Forged Ball Mount, 16,000 lbs. GTW, 1-1/4" Ball Hole, 8-1/2" Length, 1" Rise, 2" Drop, Black	2
9	63240	TowReady	Packaged 5/8" Grooved Style Hitch Pin and Clip for 2" Sq. Receivers	3	52	63043	TowReady	5 Ton Receiver Mount Pintle Hook, Solid Shank, Rating 10,000 lbs. (GTW), 2,000 lbs. (VL), Black	1
10	63241	TowReady	Packaged 1/2" Grooved Style Hitch Pin and Clip for 1-1/4" Sq. Receivers	3	53	40382	Draw-Tite	Aluminum Ball Mount, 8,000 lbs. GTW, 1" Ball Hole, 10-5/8" Length, 3" Rise, 4" Drop	1
11	580403	BullDog	Coupler Lock - Chrome	3	54	63041	TowReady	Receiver Mount Pintle Hook w/2" Ball (Inc. Grade 8 Hardware) Hook Rating 12,000 lbs. (GTW), Ball Rating 7,000 lbs. (GTW), 2,400 lbs. (VL), Black	1
12	580408	BullDog	Coupler Lock - Stainless Steel	3	55	40384	Draw-Tite	Aluminum Ball Mount, 6,000 lbs. GTW, 1" Ball Hole, 10-7/8" Length, 7" Rise, 8" Drop	1
20	580400	BullDog	5/8" Bent Pin Lock - Chrome	3	PINTLE PRODUCTS				
21	580401	BullDog	5/8" Dogbone Lock - Chrome	3	56	63011	TowReady	Pintle Hook w/2" Ball (Inc. Grade 8 Hardware) Hook Rating 16,000 lbs. (GTW), Ball Rating 10,000 lbs. (GTW), 3,000 lbs. (VL), Black	2
22	580402	BullDog	5/8" Dogbone Lock - Stainless Steel	3	57	63012	TowReady	Pintle Hook w/2-5/16" Ball (Inc. Grade 8 Hardware) Hook Rating 16,000 lbs. (GTW), Ball Rating 14,000 lbs. (GTW), 3,000 lbs. (VL), Black	1
23	580404	BullDog	5/8" Chrome Dogbone Lock w/Chrome Coupler Lock	3	58	63015	TowReady	15 Ton Regular Pintle Hook (Inc. Grade 8 Hardware) Rating 30,000 lbs. (GTW), 6,000 lbs. (VL), Black	2
31	580405	BullDog	Lock 5/8" Hitch Pin-Class III - Stainless Steel	3	59	63013	TowReady	5 Ton Regular Pintle Hook (Inc. Grade 8 Hardware) Rating 10,000 lbs. (GTW), 2,000 lbs. (VL), Black	1
32	580406	BullDog	Lock 5/8" Hitch Pin Coupler Lock Combo Stainless Steel	3	60	63057	TowReady	Pintle Hook Receiver Mount, Solid Shank, 7-5/8" Length, 12,000 lbs. (GTW), 1,200 lbs. (TW), Black	2
33	580407	BullDog	Easy Access Receiver Lock - Sleeved	3	61	40563-002	Draw-Tite	Towing Starter Kit, w/Quick-Loading 2" Sq. Ball Mount, 6,000 lbs. GTW, 1" Ball Hole, 8-1/2" Length, 3/4" Rise, 2" Drop & 2" Contents Hitch Ball w/Pin & Clip (2 Pack)	2
34	580409	BullDog	Easy Access Coupler Lock - Long	3	TOTAL CONTENTS 147				
35	580410	BullDog	Adjustable Coupler Lock	3	37-5365			4' Tall x 4' Lozier Gondola	1
43	36061	Unbranded	Class II Drawbar Kit, Drawbar (3500 lbs. w/3/4" Ball Hole 9-3/4" Length x 3-1/8" Rise), Pin and Clip, Black	1	37-2127			Rack 4' - One Half Hitch Ball / One Half Ball Mount for Lozier Gondola	1
44	36065	Unbranded	Class II Drawbar Kit, Drawbar (3500 lbs. w/3/4" Ball Hole 10" Length x 5" Rise), Pin and Clip, Black	1	37-2078			Pegboard 6" Hook, 50 pcs.	1
45	36071	Unbranded	Class II Drawbar Kit, Drawbar (3500 lbs. w/3/4" Ball Hole 7-3/16" Length x 2-5/8" Rise x 3-1/4" Drop), Pin and Clip, Black	2	MKG0197			Draw-Tite® - Tow Ready® Header Card	1
46	36078	Unbranded	Class II Drawbar Kit, Drawbar (3500 lbs. w/3/4" Ball Hole 7-3/8" Length x 4-3/4" Drop), Pin and Clip, Black	1	MKG0225			Draw-Tite® Gondola Wallpaper	2
47	40342	Draw-Tite	Quick-Loading Ball Mount, 6,000 lbs. GTW, 1" Ball Hole, 8-1/2" Length, 3/4" Rise, 2" Drop, Black	2					
48	40343	Draw-Tite	Quick-Loading Ball Mount, 6,000 lbs. GTW, 1" Ball Hole, 10-1/2" Length, 3/4" Rise, 2" Drop, Black	2					
49	40344	Draw-Tite	Quick-Loading Ball Mount, 6,000 lbs. GTW, 1" Ball Hole, 9" Length, 2-3/4" Rise, 4" Drop, Black	2					

*NOTE: See GONDOLA DISPLAYS for gondola accessory items.





DRAW-TITE® / TOW READY® PLANOGRAM



Recommending a complete layout of the best selling Draw-Tite / Tow Ready towing products and accessories.



Ref. No.	Part No.	Brand	Description	Qty
1	580408	BullDog	Stainless Steel Coupler Lock	3
2	580403	BullDog	Chrome Coupler Lock	3
3	63204	TowReady	1/2" Integral Pin & Clip for 1-1/4" Sq. Receivers - Zinc	3
4	63205	TowReady	5/8" Integral Pin & Clip for 2" Sq. Receivers - Zinc	3
5	63241	TowReady	Packaged 1/2" Grooved Style Hitch Pin and Clip for 1-1/4" Sq. Receivers	3
6	63240	TowReady	Packaged 5/8" Grooved Style Hitch Pin and Clip for 2" Sq. Receivers	3
7	63802	TowReady	Interchangeable Hitch Ball, 1" Shank, 1-7/8" & 2" Balls, 8,000 lbs. Rating	2
8	63201	TowReady	J-Pin® Anti-Rattle Pin & Barrel Lockset for 2" Sq. Receivers	2
9	63226	TowReady	Coupler Lock, Universal	2
10	580400	BullDog	5/8" Chrome Bent Pin Lock	3
11	580401	BullDog	5/8" Chrome Dogbone Lock	3
12	580402	BullDog	5/8" SS Dogbone Lock	3
13	580404	BullDog	5/8" Chrome Dogbone Lock w/ Chrome Coupler Lock	3
14	580405	BullDog	Lock 5/8" Hitch Pin-Class III Stainless Steel	3
15	580406	BullDog	Lock 5/8" Hitch Pin Coupler Lock Combo Stainless Steel	3

Ref. No.	Part No.	Brand	Description	Qty
16	580407	BullDog	Easy Access Receiver Lock Sleeved	3
17	580409	BullDog	Easy Access Receiver Lock Long	3
18	580410	BullDog	Adjustable Coupler Lock	3
19	63803	TowReady	Interchangeable Hitch Ball, 1" Shank, 1-7/8", 2", & 2-5/16" Balls, 8,000 lbs. Rating	2
20	63804	TowReady	Interchangeable Hitch Ball, 1" Shank, 2" & 2-5/16" Balls, 8,000 lbs. Rating	2
21	63810	TowReady	Hitch Ball, 1-7/8" x 3/4" x 1-1/2", 2,000 lbs. GTW Chrome	5
22	63812	TowReady	Hitch Ball, 1-7/8" x 3/4" x 2-3/8", 2,000 lbs. GTW Chrome	5
23	63816	TowReady	Hitch Ball, 1-7/8" x 1" x 2-1/8", 2,000 lbs. GTW Chrome	5
24	63820	TowReady	Hitch Ball, 2" x 3/4" x 1-1/2", 3,500 lbs. GTW Chrome	5
25	63822	TowReady	Hitch Ball, 2" x 3/4" x 2-3/8", 3,500 lbs. GTW Chrome	5
26	63824	TowReady	Hitch Ball, 2" x 3/4" x 3-3/8", 3,500 lbs. GTW Chrome	5
27	63826	TowReady	Hitch Ball, 2" x 1" x 2-1/8", 6,000 lbs. GTW Chrome	5
28	63828	TowReady	Hitch Ball, 2" x 1" x 3-3/8", 6,000 lbs. GTW Chrome	5
29	63830	TowReady	Hitch Ball, 2" x 1-1/4" x 2-3/4", 8,000 lbs. GTW Chrome	4
30	63832	TowReady	Hitch Ball, 2-5/16" x 1" x 2-1/8", 6,000 lbs. GTW Chrome	4



Ref. No.	Part No.	Brand	Description	Qty	Ref. No.	Part No.	Brand	Description	Qty
31	63834	TowReady	Hitch Ball, 2-5/16" x 1-1/4" x 2-3/4", 12,000 lbs. GTW Chrome	4	45	40383	Draw-Tite	Aluminum Ball Mount, 8,000 lbs. GTW, 1" Ball Hole, 11-7/8" Length, 5" Rise, 6" Drop	1
32	63836	TowReady	Hitch Ball, 2-5/16" x 1-1/4" x 2-3/4", 14,000 lbs. GTW Chrome	4	46	40384	TowReady	Aluminum Ball Mount, 6,000 lbs. GTW, 1" Ball Hole, 10-7/8" Length, 7" Rise, 8" Drop	2
33	63840	TowReady	Hitch Ball, 2-5/16" x 1-1/4" x 2-3/4", 20,000 lbs. GTW Chrome	4	47	80796	TowReady	Dual-Ball Ball Mount, 2" Sq. Solid Shank, 8" Length, w/ Black 2" & 2-5/16" Balls, Black	1
34	36071	TowReady	Class II Drawbar Kit, Drawbar (3500 lbs. w/3/4" Ball Hole 7-3/16" Length x 2-5/8" Rise x 3-1/4" Drop), Pin and Clip, Black	2	48	80791	TowReady	Tri-Ball Ball Mount, 2" Sq. Solid Shank w/Black 1-7/8", 2", & 2-5/16" Balls, Black	1
35	36065	Draw-Tite	Class II Drawbar Kit, Drawbar (3500 lbs. w/3/4" Ball Hole 10" Length x 5" Rise), Pin and Clip, Black	1	49	63011	TowReady	Pintle Hook w/2" Ball (Inc. Grade 8 Hardware) Hook Rating 16,000 lbs. (GTW), Ball Rating 10,000 lbs. (GTW), 3,000 lbs. (VL), Black	2
36	36078	TowReady	Class II Drawbar Kit, Drawbar (3500 lbs. w/3/4" Ball Hole 7-3/8" Length x 4-3/4" Drop), Pin and Clip, Black	1	50	63012	TowReady	Pintle Hook w/2-5/16" Ball (Inc. Grade 8 Hardware) Hook Rating 16,000 lbs. (GTW), Ball Rating 14,000 lbs. (GTW), 3,000 lbs. (VL), Black	1
37	40342	Draw-Tite	Quick-Loading Ball Mount, 6,000 lbs. GTW, 1" Ball Hole, 8-1/2" Length, 3/4" Rise, 2" Drop, Black	2	51	63015	TowReady	15 Ton Regular Pintle Hook (Inc. Grade 8 Hardware) Rating 30,000 lbs. (GTW), 6,000 lbs. (VL), Black	2
38	40343	Draw-Tite	Quick-Loading Ball Mount, 6,000 lbs. GTW, 1" Ball Hole, 10-1/2" Length, 3/4" Rise, 2" Drop, Black	2	52	63013	TowReady	5 Ton Regular Pintle Hook (Inc. Grade 8 Hardware) Rating 10,000 lbs. (GTW), 2,000 lbs. (VL), Black	1
39	40344	Draw-Tite	Quick-Loading Ball Mount, 6,000 lbs. GTW, 1" Ball Hole, 9" Length, 2-3/4" Rise, 4" Drop, Black	2	53	63057	TowReady	Pintle Hook Receiver Mount, Solid Shank, 7-5/8" Length, 12,000 lbs. (GTW), 1,200 lbs. (TW), Black	2
40	40346	Draw-Tite	Quick-Loading Ball Mount, 6,000 lbs. GTW, 1" Ball Hole, 9-1/2" Length, 4-3/4" Rise, 6" Drop, Black	1	54	40563-002	Draw-Tite	Towing Starter Kit, w/Quick-Loading 2" Sq. Ball Mount, 6,000 lbs. GTW, 1" Ball Hole, 8-1/2" Length, 3/4" Rise, 2" Drop & 2" Chrome Hitch Ball w/Pin & Clip (2 Pack)	2
41	40330	TowReady	Forged Ball Mount, 16,000 lbs. GTW, 1-1/4" Ball Hole, 8-1/2" Length, 1" Rise, 2" Drop, Black	2	TOTAL CONTENTS				146
42	63043	TowReady	5 Ton Receiver Mount Pintle Hook, Solid Shank, Rating 10,000 lbs. (GTW), 2,000 lbs. (VL), Black	1		37-5365		4' Tall x 4' Lozier Gondola	1
43	63041	Draw-Tite	Receiver Mount Pintle Hook w/2" Ball (Inc. Grade 8 Hardware) Hook Rating 12,000 lbs. (GTW), Ball Rating 7,000 lbs. (GTW), 2,400 lbs. (VL), Black	1		37-2112		Rack 4' - Ball Mount for Lozier Gondola	1
44	40382	Draw-Tite	Aluminum Ball Mount, 8,000 lbs. GTW, 1" Ball Hole, 10-5/8" Length, 3" Rise, 4" Drop	1		37-2114		Rack 4' - Hitch Ball for Lozier Gondola	1
						37-2078		Pegboard 6" Hook, 50 pcs.	1
						MKG0197		Draw-Tite® - Tow Ready® Header Card	1
						MKG0225		Draw-Tite® Gondola Wallpaper	2

*NOTE: See GONDOLA DISPLAYS for gondola accessory items.





DRAW-TITE® / TOW READY® PLANOGRAM



Recommending a complete layout of the best selling Draw-Tite / Tow Ready towing products and accessories.



Ref. No.	Part No.	Brand	Description	Qty
1	5100	Draw-Tite	Activator® Electronic Brake Control, for 1 to 2 Axle Trailers, Timed Actuated	2
2	5500	Draw-Tite	Activator® II Electronic Brake Control, for 1 to 4 Axle Trailers, Timed Actuated	2
3	5520	Draw-Tite	Activator® III Electronic Brake Control, for 1 to 4 Axle Trailers, Timed Actuated	2
4	63234	TowReady	Receiver Lock, for 1-1/4", 2" & 2-1/2" Sq. Receivers w/ Universal Stainless Steel Sleeve	2
5	63223	TowReady	Receiver Lock, Bent Pin, 5/8" for 2" & 2-1/2" Sq. Receivers	3
6	63224	TowReady	Receiver Lock, Bent Pin, 1/2" for 1-1/4" Sq. Receivers & Fifth Wheel Base Rails	3
7	118301	TowReady	T-One Connector Assembly w/Circuit Protected Converter	2
8	118336	TowReady	T-One Connector Assembly	2
9	118392	TowReady	T-One Connector Assembly	2
10	118412	TowReady	T-One Connector Assembly w/Circuit Protected ModuLite® Module	2
11	20260	TowReady	Brake Control Wiring Adapter, Ford	2
12	20261	TowReady	Brake Control Wiring Adapter, Dodge	2

Ref. No.	Part No.	Brand	Description	Qty
13	20264	TowReady	Brake Control Wiring Adapter, GM	2
14	22284	TowReady	Brake Control Wiring Adapter - 2 plugs, GM	2
15	63250	TowReady	Dogbone Lock 1/2"-5/8" Hitch Pin Coupler Combo	2
16	63228	TowReady	Coupler Lock, "Gorilla Guard" for 2" Couplers	2
17	63202	TowReady	1/2" Integral Pin & Clip for 1-1/4" Sq. Receivers - Stainless	3
18	63203	TowReady	5/8" Integral Pin & Clip for 2" Sq. Receivers - Stainless	2
19	118416	TowReady	T-One Connector Assembly	2
20	118430	TowReady	T-One Connector Assembly w/Circuit Protected ModuLite® Module	2
21	118446	TowReady	T-One Connector Assembly w/Circuit Protected ModuLite® Module	2
22	118450	TowReady	T-One Connector Assembly	2
23	118151	TowReady	Wiring Kit for Installing #118146, #118176, #118187 & #118190 ModuLite® Power Modules, Includes 20 ft. Undercar Wire, Fuse w/Holder and Attaching Terminals	2
24	119130	TowReady	Taillight Converter w/12" Leads and 60" 4-Flat Car End Connector	2

MERCHANDISING

PLANOGRAM LAYOUTS



DRAW-TITE® / TOW READY® PLANOGRAM

Cequent Performance Products Merchandising Solutions



Ref. No.	Part No.	Brand	Description	Qty
25	119146	TowReady	ModuLite® Trailer Light Power Module	2
26	119175	TowReady	Taillight Converter with Integrated Circuit Protection	2
27	119176	TowReady	ModuLite® Protector w/Integrated Circuit Protection	2
28	63227	TowReady	Coupler Lock, "Gorilla Guard" for 2-5/16" Couplers	2
29	63204	TowReady	1/2" Integral Pin & Clip for 1-1/4" Sq. Receivers - Zinc	3
30	118467	TowReady	T-One Connector Assembly w/Upgraded Circuit Protected ModuLite® Module	2
31	118496	TowReady	T-One Connector Assembly w/Upgraded Converter	2
32	118242	TowReady	Replacement OEM Tow Package Wiring Harness (7-Way)	2
33	119186	TowReady	ModuLite® Protector w/Integrated Circuit Protection & Installation Kit	2
34	119191	TowReady	ModuLite® HD Protector w/Integrated Circuit & Overload Protection Trailer Light Power Module & Installation Kit	1
35	118001	TowReady	4-Flat Car End Connector 48" Long (Includes 4 Wire Taps)	2
36	118033	TowReady	4-Flat Trailer End Connector, 48" Long	2
37	118136	TowReady	Universal Mounting Bracket and Clamp (Long)	2
38	20212	TowReady	Mounting Bracket for 7-Way OEM Connectors, Includes Screws and Nuts	3
39	63205	TowReady	5/8" Integral Pin & Clip for 2" Sq. Receivers - Zinc	3

Ref. No.	Part No.	Brand	Description	Qty
40	20143	TowReady	6-Way Round Pin Connector/4-Flat Combo Adapter Harness w/Mounting Bracket & Hardware	1
41	20144	TowReady	7-Way Flat Pin Connector/4-Flat Combo Adapter Harness w/Mounting Bracket & Hardware	1
42	20110	TowReady	Fifth Wheel Adapter Harness, 7-Way Flat Pin U.S. Car Connector Assembly 7 ft.	2
43	40563-002	Draw-Tite	Towing Starter Kit, w/Quick-Loading 2" Sq. Ball Mount, 6,000 lbs. GTW, 1" Ball Hole, 8-1/2" Length, 3/4" Rise, 2" Drop & 2" Chrome Hitch Ball w/Pin & Clip (2 Pack)	1
44	80791	TowReady	Tri-Ball Ball Mount, 2" Sq. Solid Shank w/Black 1-7/8", 2", & 2-5/16" Balls, Black	1
45	80799	TowReady	Tri-Ball Ball Mount, 2" Sq. Solid Shank w/Chrome 1-7/8", 2", & 2-5/16" Balls, Black	1
46	63226	TowReady	Coupler Lock, Universal	2
TOTAL CONTENTS				93
	37-5365		4' Tall x 4' Lozier Gondola	1
	37-2078		Pegboard 6" Hook, 50 pcs.	1
	MKG0197		Draw-Tite® - Tow Ready® Header Card (not shown)	1
	MKG0225		Draw-Tite® Gondola Wallpaper	2

*NOTE: See GONDOLA DISPLAYS for gondola accessory items.

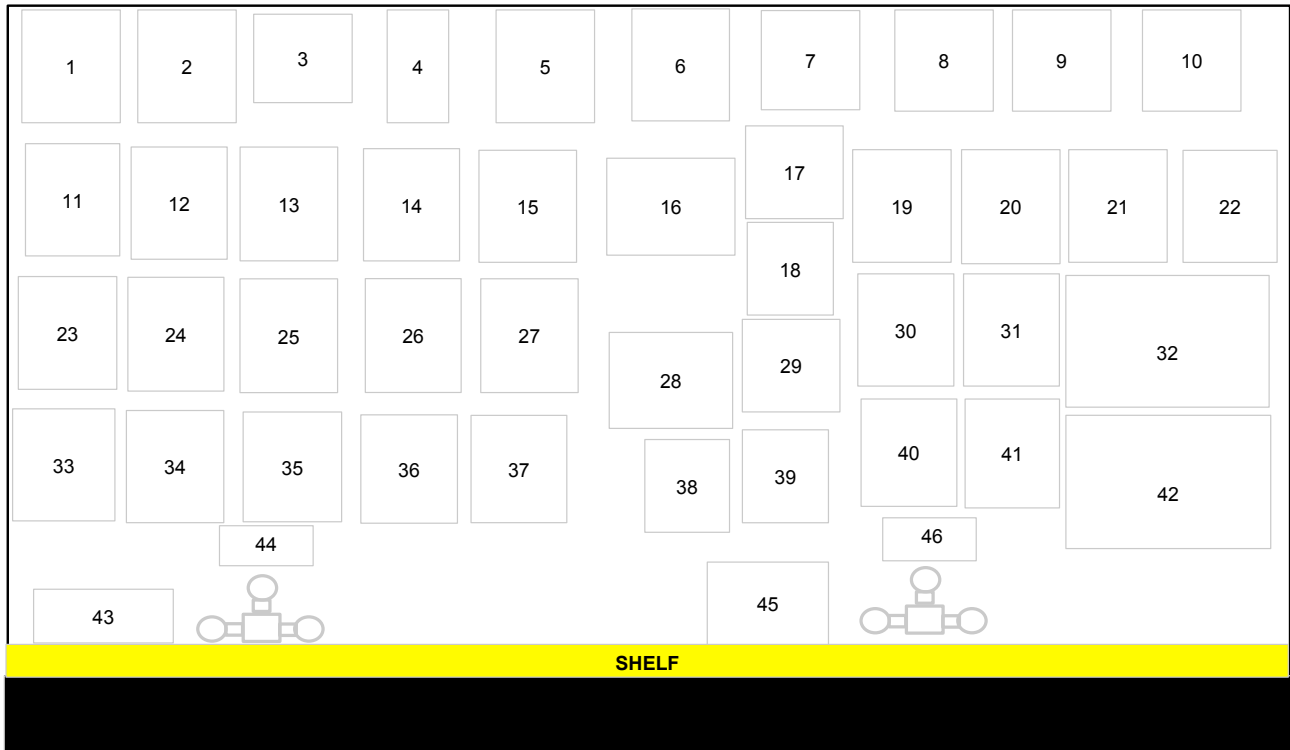



TOW READY® PLANOGRAM

Recommending a complete layout of the best selling Tow Ready wiring products and accessories.



Ref. No.	Part No.	Brand	Description	Qty
1	20321	TowReady	4-Flat to 7-Way Flat Pin Connector Adapter, Plastic	2
2	118020	TowReady	7-Way Flat Pin Connector, Car End, Plastic	2
3	118021	TowReady	7-Way Flat Pin Connector, Trailer End, Plastic	2
4	20047	TowReady	7-Way U.S. Car Replacement Socket for 7-Way Twist In OEM GM Vehicles	2
5	118136	TowReady	Universal Mounting Bracket and Clamp (Long)	2
6	118138	TowReady	Mounting Bracket for 7-Way Flat Pin Connectors, Includes Screws and Nuts	2
7	118144	TowReady	4-Flat Mounting Bracket	2
8	20144	TowReady	7-Way Flat Pin Connector/4-Flat Combo Adapter Harness w/Mounting Bracket & Hardware	1
9	20117	TowReady	7-Way Flat Pin Car End Tester	2
10	118159	TowReady	6 & 7-Way Connector Mounting Box, Universal for Round & Square Tube Hitches	2
11	118009	TowReady	4-Flat Trailer End Connector, 21' Long	2
12	20224	TowReady	7-Way Trailer Wiring Harness, U.S. Car Connector, 4'	1
13	54-98-003	Bargman	6-Way & 7-Way Plug Holder	2
14	20112	TowReady	Cover, 4-Flat LED Connector	2
15	118001	TowReady	4-Flat Car End Connector 48" Long (Includes 4 Wire Taps)	2
16	118033	TowReady	4-Flat Trailer End Connector, 48" Long	2
17	118045	TowReady	4-Flat Plug Loop, 60" Long (Includes 4 Wire Taps)	2
18	118185	TowReady	4-Flat Plug Loop, 18" Long (Includes 4 Wire Taps)	2
19	118301	TowReady	T-One Connector Assembly w/Circuit Protected Converter	2
20	118336	TowReady	T-One Connector Assembly w/Converter	2
21	118392	TowReady	T-One Connector Assembly	2
22	118215	TowReady	5-Flat Plug Loop 60" Long, Car & Trailer End Wiring Harness	1
23	20116	TowReady	6-Way Car End Tester	2
24	20114	TowReady	4-Flat Car End Tester	3

Ref. No.	Part No.	Brand	Description	Qty
25	118412	TowReady	T-One Connector Assembly w/Circuit Protected ModuLite® Module	2
26	118416	TowReady	T-One Connector Assembly	2
27	118430	TowReady	T-One Connector Assembly w/Circuit Protected ModuLite® Module	2
28	118446	TowReady	T-One Connector Assembly w/Circuit Protected ModuLite® Module	2
29	118004	TowReady	4-Flat Trailer End Connector, 12" Long	2
30	118016	TowReady	5-Flat 72" Car End Wiring Harness	2
31	118017	TowReady	5-Flat 48" Trailer End Wiring Harness	2
32	119130	TowReady	Taillight Converter w/12" Leads and 60" 4-Flat Car End Connector	2
33	119146	TowReady	ModuLite® Trailer Light Power Module	2
34	119175	TowReady	Taillight Converter with Integrated Circuit Protection	2
35	119176	TowReady	ModuLite® Protector w/Integrated Circuit Protection	2
36	118450	TowReady	T-One Connector Assembly	2
37	118467	TowReady	T-One Connector Assembly w/Upgraded Circuit Protected ModuLite® Module	2
38	118496	TowReady	T-One Connector Assembly w/Upgraded Converter	2
39	118036	TowReady	6-Way Round Pin Connector, Car End, Metal	2
40	118037	TowReady	6-Way Round Pin Connector, Trailer End, Metal	2
41	119186	TowReady	ModuLite® Protector w/Integrated Circuit Protection & Installation Kit	2
42	119191	TowReady	ModuLite® HD Protector w/Integrated Circuit & Overload Protection Trailer Light Power Module & Installation Kit	1
TOTAL CONTENTS				81
	37-5365		4' Tall x 4' Lozier Gondola	1
	37-2078		Pegboard 6" Hook, 50 pcs.	1
	MKG0197		Draw-Tite® - Tow Ready® Header Card (not shown)	1
	MKG0225		Draw-Tite® Gondola Wallpaper	2

*NOTE: See GONDOLA DISPLAYS for gondola accessory items.



TOW READY® PLANOGRAM

Cequent Performance Products Merchandising Solutions

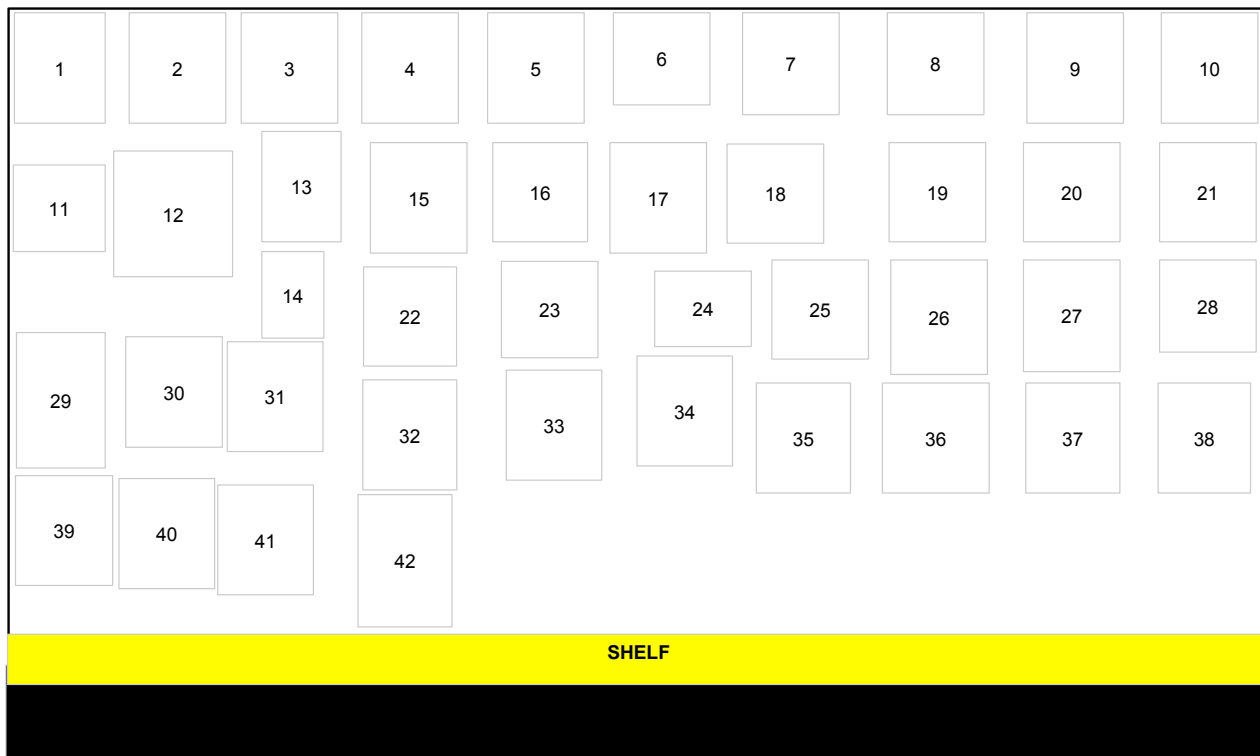



BULLDOG® / TOW READY™ PLANOGRAM

Recommending a complete layout of the best selling BULLDOG / Tow Ready towing accessories.



Ref. No.	Part No.	Brand	Description	Qty.
1	580402	BULLDOG	5/8" Stainless Steel Dogbone Lock	3
2	580404	BULLDOG	5/8" Chrome Dogbone Lock w/ Chrome Coupler Lock	3
3	580401	BULLDOG	5/8" Chrome Dogbone Lock	3
4	580400	BULLDOG	5/8" Chrome Bent Pin Lock	3
5	63249	Tow Ready	Lock 5/8" Hitch Pin Coupler Lock Combo	3
6	63248	Tow Ready	Lock 5/8" Hitch Pin - Class III	3
7	63250	Tow Ready	Dogbone Lock 1/2"-5/8" Hitch Pin Coupler Combo	3
8	63234	Tow Ready	Dogbone Lock 1/2"-5/8" Hitch Pin	6
9	580406	BULLDOG	5/8" Stainless Steel Receiver Lock w/ SS Coupler Lock	3
10	580405	BULLDOG	5/8" Stainless Steel Receiver Lock	3
11	580407	BULLDOG	5/8" - 1/2" Easy Access Receiver Lock	3
12	580409	BULLDOG	Easy Access Coupler Lock	3
13	63223	Tow Ready	Lock 5/8" Hitch Pin - Class III	6
14	63224	Tow Ready	Lock 1/2" Hitch Pin - Class III	6
15	63230	Tow Ready	Brass Coupler Lock	6
16	63225	Tow Ready	Coupler Lock	6
17	580403	BULLDOG	Chrome Coupler Lock	3
18	580408	BULLDOG	Stainless Steel Coupler Lock	6
19	580410	BULLDOG	Adjustable Easy Access Coupler Lock	3
20	63253	Tow Ready	5/8" Bent Pin Lock, 3-1/2" Span - Class V	6
21	63254	Tow Ready	Fifth Wheel Rail Lock	6
22	63252	Tow Ready	5/8" Dogbone Lock, 3-1/2" Span - Class V	6
23	63251	Tow Ready	King Pin Lock	12
24	63226	Tow Ready	Universal Coupler Lock	3
TOTAL CONTENTS				78
	37-2078		Pegboard 6" Hook, 50 pcs.	1
	37-5365		4' Tall x 4' Lozier Gondola	1

*NOTE: See GONDOLA DISPLAYS for gondola accessory items.

PLANOGRAM LAYOUTS



BULLDOG® / TOW READY™ PLANOGRAM
Cequent Performance Products Merchandising Solutions

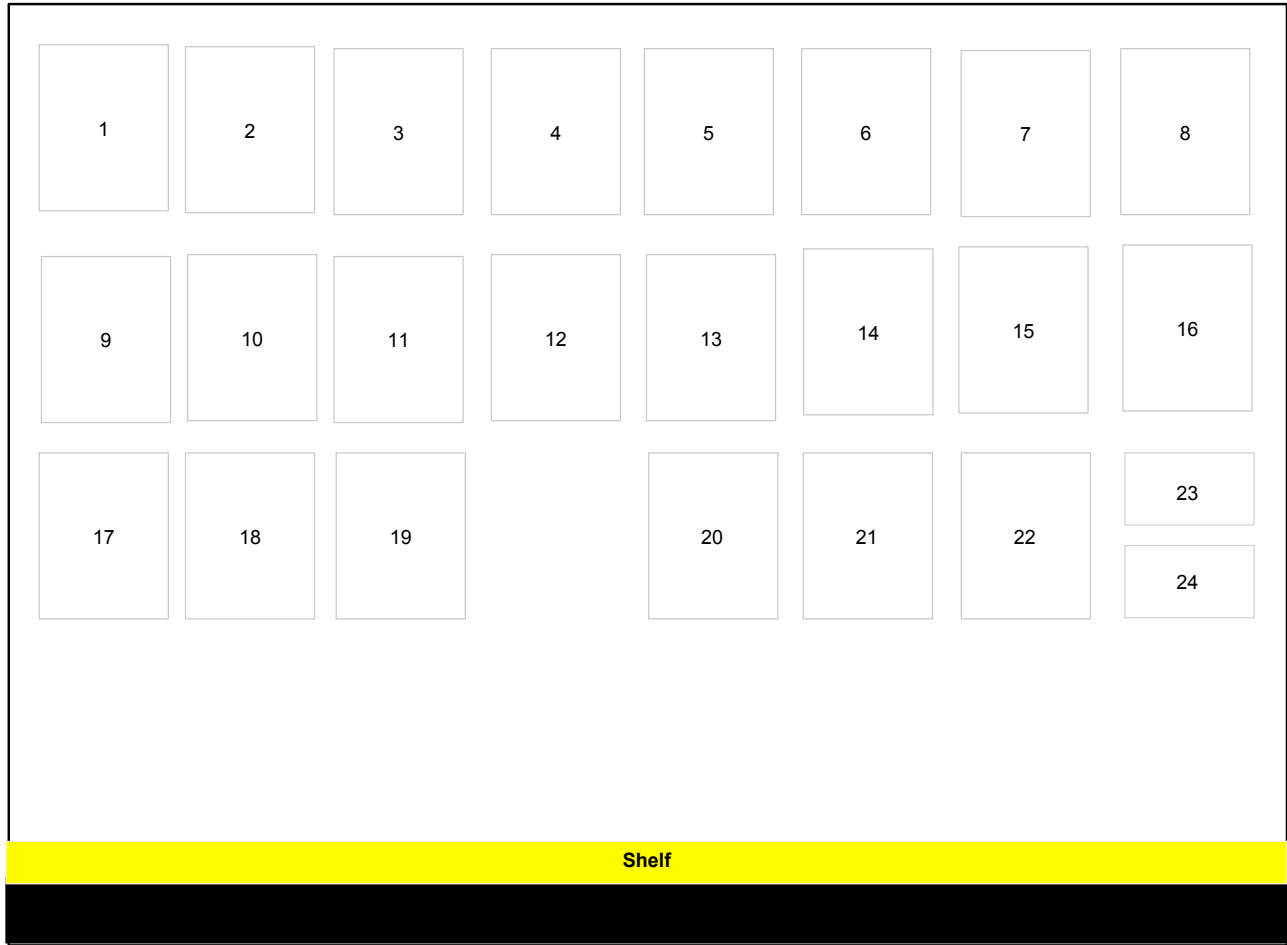



BARGMAN® PLANOGRAM

Recommending a complete layout of the best selling Bargman incandescent and LED lighting products.



3' INCANDESCENT INTERIOR/EXTERIOR LIGHTING

Ref. No.	Part No.	Brand	Description	Qty.	Ref. No.	Part No.	Brand	Description	Qty.
1	41-30-001	Bargman	Clearance Light Module #30 2" Red	3	20	31-59-012	Bargman	Amber Lens #59	3
2	41-30-002	Bargman	Clearance Light Module #30 2" Amber	3	21	3176123	Bargman	Interior Light #76 Single White	1
3	41-31-001	Bargman	Clearance Light Module #31 2-1/2" Red	3	22	3176123	Bargman	Interior Light #76 Single White	1
4	41-31-002	Bargman	Clearance Light Module #31 2-1/2" Amber	3	23	31-84-010	Bargman	Red Lens #84/85/86	2
5	41-37-031	Bargman	Clearance Lens #37 Red w/Black Base w/Wire	3	24	31-84-016	Bargman	Amber Lens #84/85/86	2
6	41-37-032	Bargman	Clearance Lens #37 Amber w/Black Base w/Wire	3	25	31-92-001	Bargman	Stop/Tail/Turn #92 Surface Mount w/White Base	2
7	31-78-531	Bargman	Porch/Utility Light #78 White w/Clear Lens	2	26	31-92-003	Bargman	Stop/Tail/Turn #92 Surface Mount w/License Light & Brkt w/White Base	2
8	31-78-532	Bargman	Porch/Utility Light #78 White w/Amber Lens	2	27	31-84-700	Bargman	Backup Lens #84/85/86 - Lens Mounted Vertical	2
9	31-59-001	Bargman	Clearance Light #59 Red w/White Base	3	28	31-84-711	Bargman	Backup Lens #84/85/86 - Lens Mounted Horizontal	2
10	31-59-002	Bargman	Clearance Light #59 Amber w/White Base	3	29	31-86-101	Bargman	Stop/Tail/Turn #86 Red w/Black Base	2
11	32-003441	Bargman	Clearance Light Dual Bulb Red	3	30	31-86-104	Bargman	Turn #86 Amber w/Black Base	2
12	32-003440	Bargman	Clearance Light Dual Bulb Amber	3	31	31-86-103	Bargman	Backup Vertical Mount #86 w/Black Base	2
13	41-38-031	Bargman	Clearance Lens #38 Red w/Black Base w/Wire	3	32	31-2823285	Bargman	Trailer Light Kit Under 80" w/25 Ft. Wire Harness	2
14	41-38-032	Bargman	Clearance Lens #38 Amber w/Black Base w/Wire	3	TOTAL CONTENTS				82
15	31-67-808	Bargman	Clearance Light #678 Red w/White Base	3		37-5365		4' Tall x 4' Lozier Gondola	1
16	31-67-809	Bargman	Clearance Light #678 Amber w/White Base	3		37-2078		Pegboard 6" Hook, 50 pcs.	1
17	31-99-001	Bargman	Clearance Light #99 Red	3		MKG0234		Bargman® Header Card (not shown)	1
18	31-99-002	Bargman	Clearance Light #99 Amber	3		MKG0232		Bargman® Gondola Wallpaper	2
19	31-59-010	Bargman	Red Lens #59	3					



2' LED EXTERIOR LIGHTING

Ref. No.	Part No.	Brand	Description	Qty.	Ref. No.	Part No.	Brand	Description	Qty.
33	42-30-401	Bargman	LED Clearance Light Module #30 2" Red	3	47	42-99-401	Bargman	LED Clearance Light #99 Red	3
34	42-30-402	Bargman	LED Clearance Light Module #30 2" Red	3	48	42-99-402	Bargman	LED Clearance Light #99 Amber	3
35	42-31-403	Bargman	LED Clearance Light Module #31 2-1/2" Red w/ Reflex	3	49	42-42-401	Bargman	LED Clearance Light #42 Red	3
36	42-31-404	Bargman	LED Clearance Light Module #31 2-1/2" Amber w/Reflex	3	50	42-42-402	Bargman	LED Clearance Light #42 Amber	3
37	42-86-410	Bargman	LED Upgrade Red Clearance Light Wrap-Around #86 Light Module	3	51	42-84-410	Bargman	LED Upgrade Red Stop/Tail/Turn Module #84/85/86	2
38	42-86-412	Bargman	LED Upgrade Amber Clearance Light Wrap-Around #86 Light Module	3	52	42-84-412	Bargman	LED Upgrade Amber Turn Module #84/85/86	2
39	42-59-401	Bargman	LED Clearance Light #59 Red w/White Base w/ Pigtail	3	53	42-84-414	Bargman	LED Upgrade Backup Lens Module #84/85/86	2
40	42-59-402	Bargman	LED Clearance Light #59 Amber w/White Base w/Pigtail	3	54	42-86-101	Bargman	LED Stop/Tail/Turn #86 Red w/Black Base	2
41	42-59-410	Bargman	LED Upgrade Red Clearance Light #59 Lens Module	3	55	42-86-104	Bargman	LED Turn #86 Amber w/Black Base	2
42	42-59-412	Bargman	LED Upgrade Amber Clearance Light #59 Lens Module	3	56	71-78-010	Bargman	Reflector Red w/Mounting Holes & Adhesive Back	3
43	42-38-033	Bargman	LED Clearance Light #38 Red w/Black Base w/ Pigtail	3	57	71-78-020	Bargman	Reflector Amber w/Mounting Holes & Adhesive Back	3
44	42-38-034	Bargman	LED Clearance Light #38 Amber w/Black Base w/Pigtail	3	58	71-55-010	Bargman	Reflector Red 2-3/16" w/Adhesive Back	3
45	42-37-401	Bargman	LED Clearance Light Module #37 Red	3	59	71-55-020	Bargman	Reflector Amber 2-3/16" w/Adhesive Back	3
46	42-37-402	Bargman	LED Clearance Light Module #37 Amber	3	60	31-407560	Bargman	LED Trailer Light Kit 4x6 Waterproof Low Profile	1
					61	31-407540	Bargman	LED Trailer Light Kit 3x8 Waterproof Low Profile	1
TOTAL CONTENTS									82
					37-5367			4' Tall x 2' Lozier Gondola	1
					37-2078			Pegboard 6" Hook, 50 pcs.	1
					MKG0233			Bargman® Header Card (not shown)	1
					MKG0232			Bargman® Gondola Wallpaper	1

*NOTE: See GONDOLA DISPLAYS for gondola accessory items.

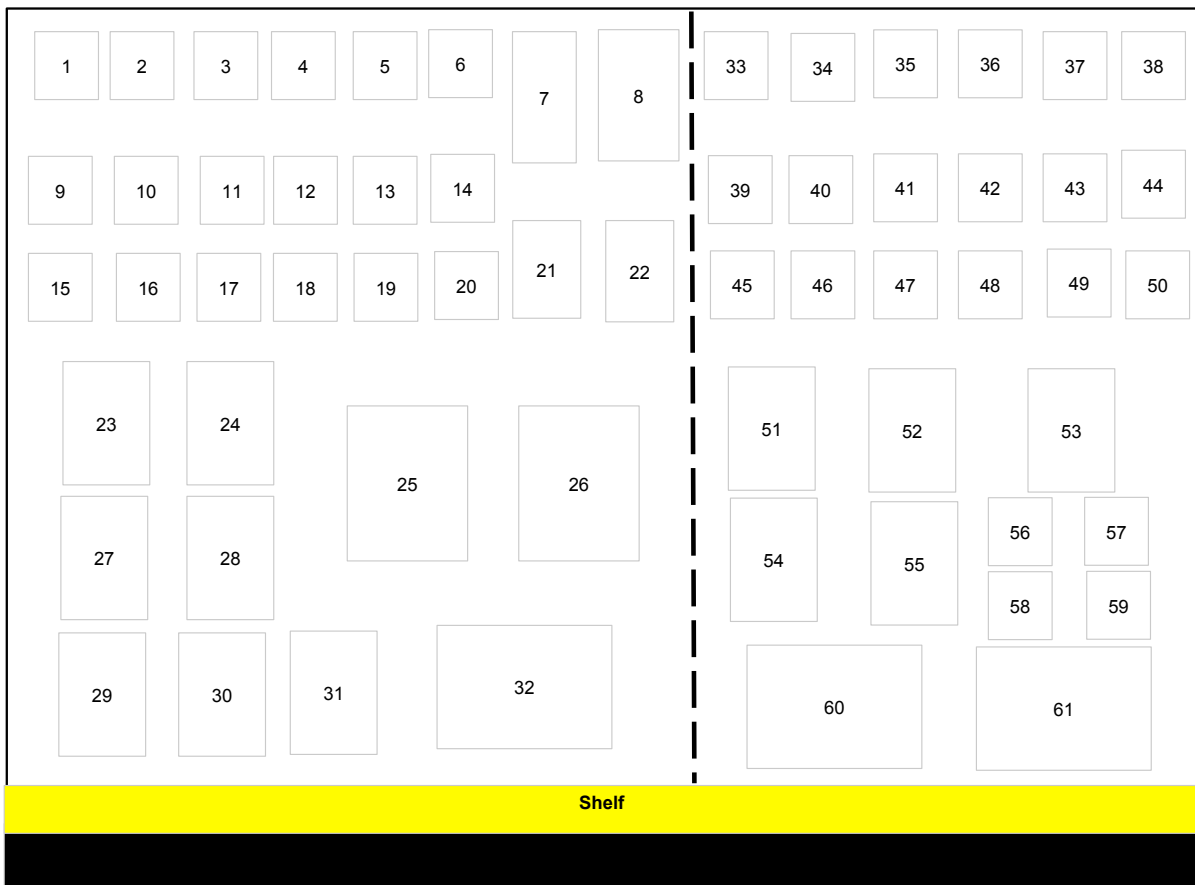



WESBAR® PLANOGRAM

Recommending a complete layout of the best selling Wesbar LED lighting products.



Ref. No.	Part No.	Brand	Description	Qty.
1	401565	Wesbar	LED Waterproof Marker/Clearance Lamp, Stud Mount, Amber	2
2	401566	Wesbar	LED Waterproof Marker/Clearance Lamp, Stud Mount, Red	2
3	54201-001	Wesbar	LED Clearance Light Amber w/Chrome Bezel (47-106853 & 47-106020)	2
4	54201-002	Wesbar	LED Clearance Light Red w/Chrome Bezel (47-107047 & 47-106020)	2
5	54005	Wesbar	LED 6" Oval Courtesy Light Clear w/Grommet w/Pigtail	2
6	42-106858	Wesbar	LED Light Bar w/Red Lens	2
7	401580	Wesbar	LED Waterproof Marker/Clearance Lamp, Amber	2
8	401581	Wesbar	LED Waterproof Marker/Clearance Lamp, Red	2
9	401576	Wesbar	LED Waterproof Marker/Clearance Lamp, 2" Round Grommet Mount, Amber	2
10	401577	Wesbar	LED Waterproof Marker/Clearance Lamp, 2" Round Grommet Mount, Red	2
11	401578	Wesbar	LED Waterproof Marker/Clearance Lamp, 2 1/2" Round Grommet Mount, Amber	2
12	401579	Wesbar	LED Waterproof Marker/Clearance Lamp, 2 1/2" Round Grommet Mount, Red	2

Ref. No.	Part No.	Brand	Description	Qty.
13	407535	Wesbar	LED Waterproof Stop, Turn and Tail lamp, Roadside	2
14	407530	Wesbar	LED Waterproof Stop, Turn and Tail lamp, Curbside	2
15	281595	Wesbar	LED - Wrap-Around 8-Function, Roadside	2
16	281594	Wesbar	LED - Wrap-Around 7-Function, Curbside	2
17	54006	Wesbar	LED 6" Oval Tail Light Red w/Grommet w/Pigtail	2
18	54004	Wesbar	LED 6" Oval Tail Light Red w/Chrome Trim Snap Ring	2
19	407555	Wesbar	LED Waterproof STL-80 Stop, Turn, and Tail Lamp, Roadside	2
20	407550	Wesbar	LED Waterproof STL-80 Stop, Turn, and Tail Lamp, Curbside	2
21	401567	Wesbar	LED Waterproof ID Light Bar	2
22	407540	Wesbar	LED Waterproof Low Profile Trailer Light Kit	1
23	407560	Wesbar	LED Waterproof STL-80 Trailer Light Kit	1
24	287512	Wesbar	LED Submersible Under 80" Trailer Light Kit	1
TOTAL CONTENTS				45
	37-5367		4' Tall x 2' Lozier Gondola	1
	37-2078		Pegboard 6" Hook, 50 pcs.	1
	MKG0231		Wesbar® Header Card	1
	MKG0230		Wesbar® Gondola Wallpaper	1

*NOTE: See GONDOLA DISPLAYS for gondola accessory items.



WESBAR® PLANOGRAM

Recommending a complete layout of the best selling Wesbar incandescent lighting and wiring products.



Ref. No.	Part No.	Brand	Description	Qty.
1	203131	Wesbar	Clearance Marker Lamp w/Reflector, Amber	2
2	203133	Wesbar	Clearance Marker Lamp w/Reflector, Red	2
3	203111	Wesbar	Clearance Marker Light, Amber	2
4	203113	Wesbar	Clearance Marker Light, Red	2
5	203292	Wesbar	Sealed Clearance Marker Lamp, Amber	2
6	203293	Wesbar	Sealed Clearance Marker Lamp, Red	2
7	003148	Wesbar	Clearance Marker Light Amber w/Reflex Lens, PC Rated	2
8	403348	Wesbar	Sealed Bulb Replacement Tail Lamp Capsule	2
9	403080	Wesbar	Sealed Oval Tail Lamp Kit	2
10	203309	Wesbar	Waterproof ID Bar, Chrome, Red	2
11	003211	Wesbar	Black Plastic License Plate Bracket	2
12	203395	Wesbar	Sealed Clearance Marker Lamp Module Snap-Lock, Amber	2

Ref. No.	Part No.	Brand	Description	Qty.
13	203396	Wesbar	Sealed Clearance Marker Lamp Module Snap-Lock, Red	2
14	203233	Wesbar	Waterproof Clearance Marker Lamp, Stud Mount, Amber	2
15	203234	Wesbar	Waterproof Clearance Marker Lamp, Stud Mount, Red	2
16	203294	Wesbar	Sealed Clearance Marker Lamp, Amber	2
17	203295	Wesbar	Sealed Clearance Marker Lamp, Red	2
18	707254	Wesbar	Double Ended 4-Way 2ft.	2
19	707255	Wesbar	Double Ended 5-Way 2ft.	2
20	2523024	Wesbar	Submersible Over 80" Tail Light, Roadside	2
21	2523074	Wesbar	Submersible Over 80" Tail Light, Curbside	2
22	403025	Wesbar	Submersible Over 80" Tail Light, Roadside	2
23	403075	Wesbar	Submersible Over 80" Tail Light, Curbside	2
24	403087	Wesbar	Sealed Oval Lamp Module, Clear	2



WESBAR® PLANOGRAM
Cequent Performance Products Merchandising Solutions

Ref. No.	Part No.	Brand	Description	Qty.
25	403085	Wesbar	Sealed Oval Tail Lamp Module, Red	2
26	707250	Wesbar	7-Way to 5-Way Adapter	2
27	767940	Wesbar	Adapter - 7-Way Blade to 5-Way Flat	2
28	767941	Wesbar	4-Way Tester w/LED	2
29	767942	Wesbar	5-Way Tester w/LED and Dust Cap	2
30	2523023	Wesbar	Submersible Under 80" Tail Lamp, Roadside	2
31	2523073	Wesbar	Submersible Under 80" Tail Lamp, Curbside	2
32	403026	Wesbar	Waterproof Over 80" Low Profile Tail Lamp, Roadside	2
33	403076	Wesbar	Waterproof Over 80" Low Profile Tail Lamp, Curbside	2
34	707261	Wesbar	25' 4-Flat Wishbone Wire Harness Kit	2
35	707270	Wesbar	4-Way Trunk/Trailer Connector Kit, 66"	2

Ref. No.	Part No.	Brand	Description	Qty.
36	707272	Wesbar	4-Way Trunk Connector 6' with 6' Ground	2
37	707286	Wesbar	4-Way Trailer Connector, 18" Wishbone	2
38	707275	Wesbar	4-Way Trunk Connector, 4' with 18" Ground	2
39	2527511	Wesbar	Submersible, Under 80" Trailer Light Kit	1
40	007509	Wesbar	Waterproof Low Profile Trailer Light Kit	1
41	707105	Wesbar	25' 5-Flat Wishbone Wire Harness Kit	2
42	707273	Wesbar	5-Way Trunk Connector, 6' with 4' Ground	2
43	707283	Wesbar	5-Way Trunk Connector 4' with 4' Ground	2
TOTAL CONTENTS				45
	37-5365		4' Tall x 4' Lozier Gondola	1
	37-2078		Pegboard 6" Hook, 50 pcs.	1
	MKG0235		Wesbar® Header Card	1
	MKG0230		Wesbar® Gondola Wallpaper	2

*NOTE: See GONDOLA DISPLAYS for gondola accessory items.

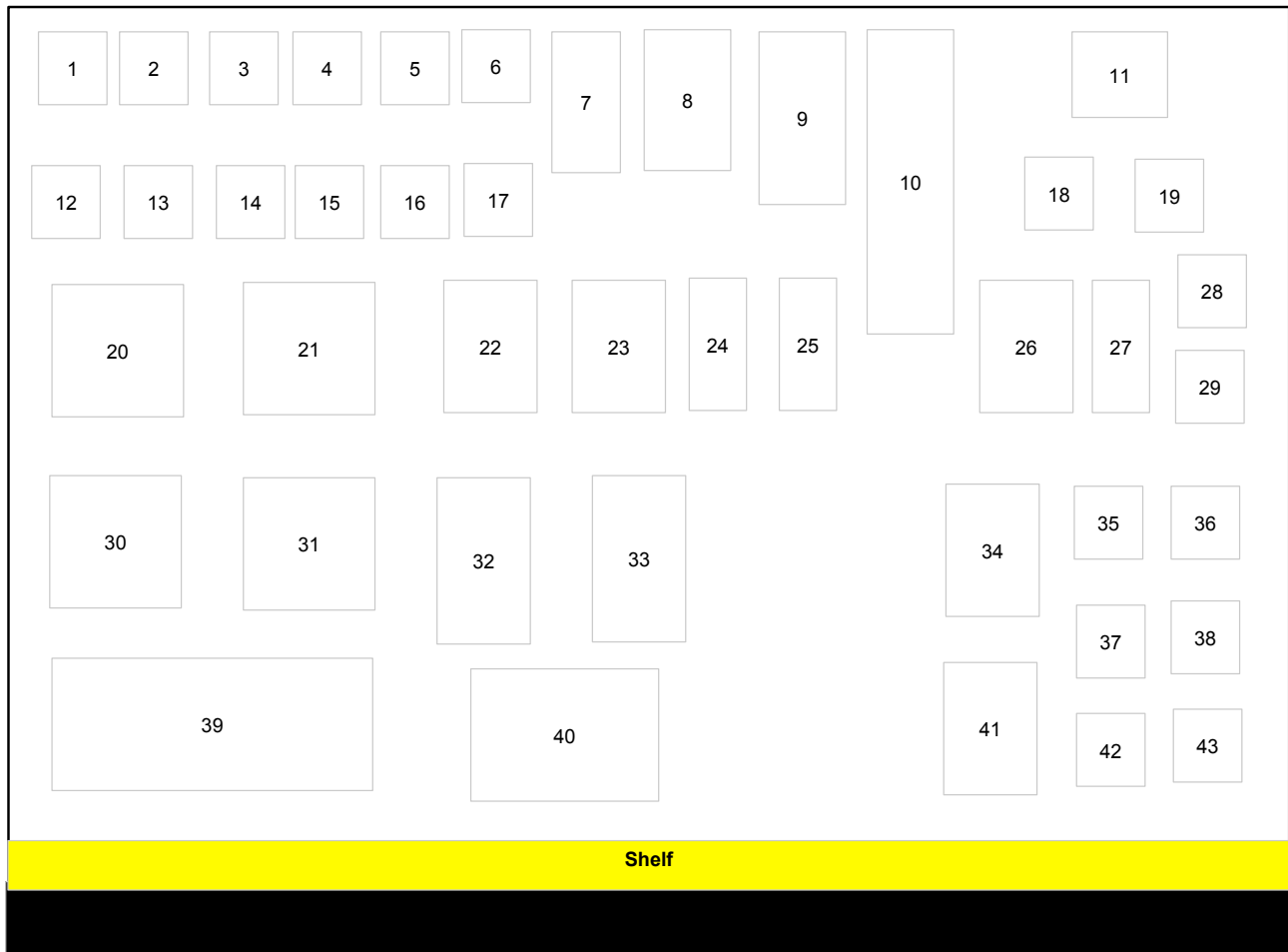



BARGMAN® / WESBAR® PLANOGRAM



Recommending a complete layout of the best selling Bargman / Wesbar incandescent and LED lighting products.



Ref. No.	Part No.	Brand	Description	Qty.
1	32-003440	Bargman	Clearance Light Red	1
2	32-003441	Bargman	Clearance Light Amber	1
3	42-59-401	Bargman	Clearance Light LED #59 Red w/White Base	2
4	42-59-402	Bargman	Clearance Light LED #59 Amber w/White Base	2
5	31-59-001	Bargman	Clearance Light #59 Red with White Base	1
6	31-59-002	Bargman	Clearance Light #59 Amber with White Base	1
7	42-99-401	Bargman	Clearance Light LED #99 Red	2
8	42-99-402	Bargman	Clearance Light LED #99 Amber	2
9	71-55-010	Bargman	Reflector 2-3/16 Round Adhesive Mount Red	1
10	71-55-020	Bargman	Reflector 2-3/16 Round Adhesive Mount Amber	1
11	41-38-031	Bargman	Clearance Light Sealed #38 Red with Black Base and Wire Assembly	1
12	41-38-032	Bargman	Clearance Light Sealed #38 Amber with Black Base and Wire Assembly	1
13	42-30-402	Bargman	LED 2 Round Amber	2
14	42-30-401	Bargman	LED 2 Round Red	2
15	42-31-404	Bargman	LED 2-1/2 Round Amber w/Grommet & Pigtail Reflex	2
16	42-31-403	Bargman	LED 2-1/2 Round Red w/Grommet & Pigtail Reflex	2
17	31-99-001	Bargman	Clearance Light #99 Red	1
18	31-99-002	Bargman	Clearance Light #99 Amber	1
19	42-59-410	Bargman	Upgrade Kit LED #59 Red	2
20	42-59-412	Bargman	Upgrade Kit LED #59 Amber	2
21	31-59-010	Bargman	Clearance Light Replacement Lens #59 Red	1

Ref. No.	Part No.	Brand	Description	Qty.
22	31-59-012	Bargman	Clearance Light Replacement Lens #59 Amber	1
23	42-42-401	Bargman	Clearance Light LED #42 Red w/Reflex, Stud Mount	2
24	42-42-402	Bargman	Clearance Light LED #42 Amber w/Reflex, Stud Mount	2
25	41-31-001	Bargman	Clearance Light Sealed Module, #31 Red	1
26	41-31-002	Bargman	Clearance Light Sealed Module, #31 Amber	1
27	42-37-401	Bargman	37 Series LED Red	2
28	42-37-402	Bargman	37 Series LED Amber	2
29	41-30-001	Bargman	Clearance Light Sealed Module, #30 Red	1
30	41-30-002	Bargman	Clearance Light Sealed Module, #30 Amber	1
31	42-38-034	Bargman	Clearance Light LED #38 Amber with Black Base with Pigtail	2
32	42-38-033	Bargman	Clearance Light LED #38 Red with Black Base with Pigtail	2
33	71-78-010	Bargman	Reflector Rectangular Red 3-1/4 x 1-1/2 - Adhesive	1
34	71-78-020	Bargman	Reflector Rectangular Amber 3-1/4 x 1-1/2 - Adhesive	1
35	42-86-410	Bargman	LED Wrap-Around Clearance Light Upgrade Module Red	2
36	42-86-412	Bargman	LED Wrap-Around Clearance Light Upgrade Module Amber	2
37	203233	Wesbar	Side Marker/Clearance Light Amber w/White Stud-Mount Base, PC Rated	1
38	203234	Wesbar	Side Marker/Clearance Light Red w/White Stud-Mount Base, PC Rated	1
39	203292	Wesbar	Clearance Lens #37 Amber w/Black Base and Wire	1



Ref. No.	Part No.	Brand	Description	Qty.
40	203293	Wesbar	Clearance Lens #37 Red w/Black Base and /Wire	1
41	42-84-412	Bargman	LED #84 Series Turn Light Lens Upgrade Module Amber w/Connector and Lens Screws	2
42	42-84-410	Bargman	LED #84 Series Stop, Tail, Turn Light Lens Upgrade Module Red w/Connector and Lens Screws	2
43	42-86-104	Bargman	Taillight LED #86 Amber Turn with Black Base	2
44	42-86-101	Bargman	Taillight LED #86 Single Stop, Tail, Turn with Black Base	2
45	42-84-414	Bargman	LED #84 Backup Lens Module Red Reflex w/Clear Center w/Bulb Socket Plug	2
46	2523073	Wesbar	6-Function Submersible Under 80 Taillight, Right/ Curbside	1
47	2523023	Wesbar	7-Function Submersible Under 80 Taillight, Left/ Roadside	1
48	403335	Wesbar	Replacement Part, Over 80 Taillight Lens for Part #403010, #403060, #403023 & #403073	1
49	203310	Wesbar	Red, Standard, Black Painted Bar	1
50	31-84-700	Bargman	Taillight Replacement Lens Horizontal #84, #85, & #86 Clear Backup	1
51	31-84-711	Bargman	Taillight Replacement Lens Vertical #84, #85, & #86 Clear Backup	1
52	31-86-104	Bargman	Taillight #86 Single Amber Turn w/Black Base	1
53	31-86-101	Bargman	Taillight #86 Single Stop-Tail-Turn w/Black Base	1
54	31-86-103	Bargman	Taillight #86 Single Vertical Backup w/Black Base	1
55	403076	Wesbar	Taillight, Waterproof Low-Profile Over 80 - Right/ Curbside	1

Ref. No.	Part No.	Brand	Description	Qty.
56	403026	Wesbar	Taillight, Waterproof Low-Profile Over 80 - Left/ Roadside	1
57	403080	Wesbar	Taillight, Sealed Oval Set (Module, Grommet & Harness)	1
58	283561	Wesbar	LED 6 Oval Stop/Tail/Turn, Red	2
59	283564	Wesbar	LED 6 Oval Stop/Tail/Turn, Amber	2
60	44-00-003	Bargman	Pigtail - 3 Wire Sealed	1
61	44-06-020	Bargman	Grommet - Sealed 6 Oblong Taillight	1
62	44-01-031	Bargman	Taillight Sealed Stop, Tail, Turn 4 Round with Grommet and Standard Pigtail	1
63	31-84-010	Bargman	Taillight Replacement Lens #84, #85, & #86 Red	1
64	31-84-016	Bargman	Taillight Replacement Lens #84, #85, & #86 Amber	1
65	403348	Wesbar	Replacement Part, Sonically Sealed Waterproof Bulb Capsule for Part #007509	1
66	2527511	Wesbar	Submersible Under 80 Taillight Kit w/25' Harness (w/o Clearance/Side Marker Lights) INCAND;TRAILER KIT	1
67	31-2823285	Bargman	Taillight Kit w/25' Wire Harness, w/Rectangular Clearance/Side Marker Lights	1
TOTAL CONTENTS				91
	37-5365		4' Tall x 4' Lozier Gondola	1
	37-2078		Pegboard 6" Hook, 50 pcs.	1
	MKG0231		Wesbar® Header Card (not shown)	1
	MKG0233		Bargman® Header Card (not shown)	1
	MKG0230		Wesbar® Gondola Wallpaper	1
	MKG0232		Bargman® Gondola Wallpaper	1

*NOTE: See GONDOLA DISPLAYS for gondola accessory items.

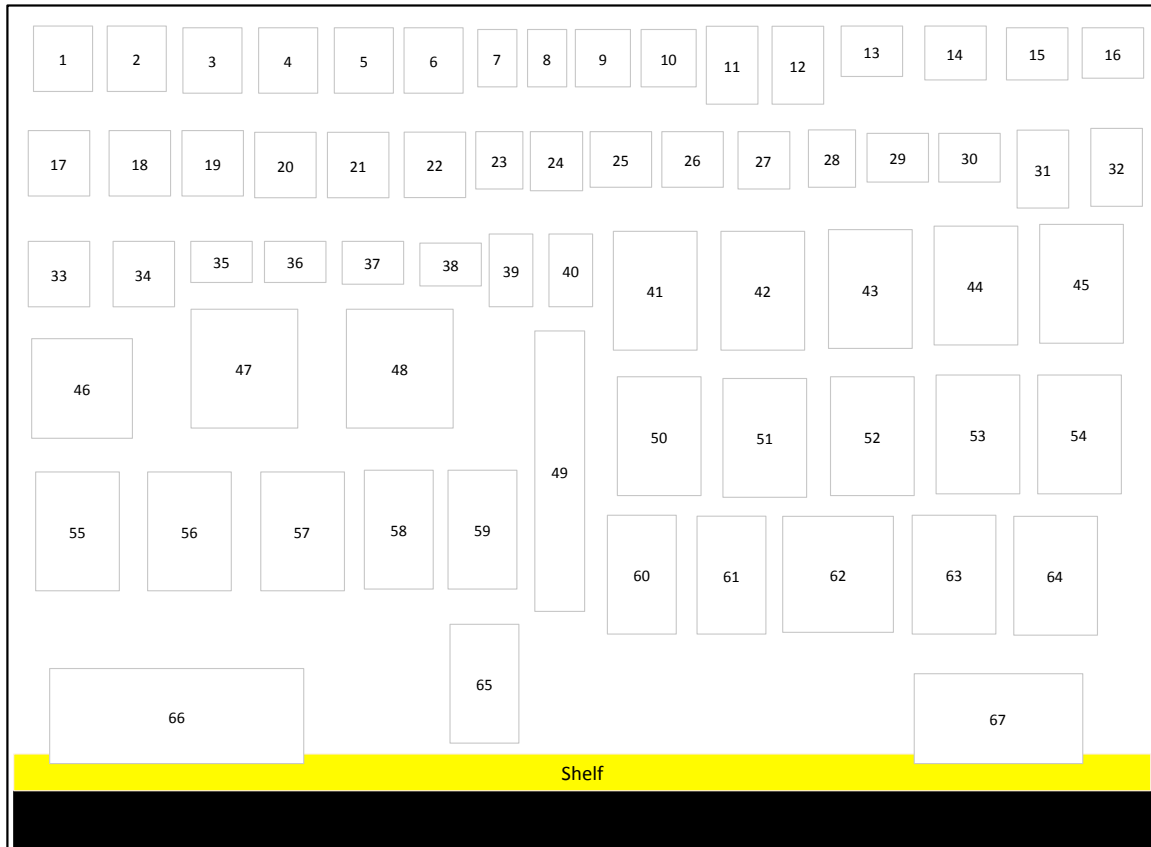



ROLA® / HIGHLAND® PLANOGRAM



Recommending a complete layout of the best selling ROLA / Highland cargo management products.



Ref. No.	Part No.	Brand	Description	Qty
1	1157200	Highland	Titan Tie Down 1800 lbs. 1 x 10' 2 per pack	3
2	1157300	Highland	Titan Tie Down 1800 lbs. 1 x 10' 4 per pack	3
3	1157100	Highland	Titan Tie Down 1800 lbs. 1 x 14' 1 per pack	3
4	1152101	Highland	Ratchet Tie Down 1 x 6' Padded Handle	3
5	1151601	Highland	Ratchet Tie Down 1.25 x 10' with Hooks	3
6	1151701	Highland	Ratchet Tie Down 1.5 x 15' with Hooks	3
7	1152500	Highland	Ratchet Tie Down 2 x 25' with Hooks	2
8	7330	Highland	Cargo Net	2
9	59200	Highland	Cargo Net 36 x 48	3
10	9203200	Highland	Stretch Cord 32" 2 pack	2
11	9500100	Highland	Cargo Net	2
12	9500500	Highland	Pick Up Truck Cargo Net	2
13	44209	Highland	Recessed Floor/Wall Tie Down	1
14	44202	Highland	Recessed Ring Tie Down for Rope	4

Ref. No.	Part No.	Brand	Description	Qty
15	44201	Highland	Surface Mount Ring Tie Down for Rope	3
16	9402400	Highland	Bungee Cord 24" Red	4
17	1017800	Highland	Tow Strap 2 x 20' with Loop	2
18	9500600	Highland	Universal Truck Net	2
19	9501000	Highland	Storage Net 48 x 60 x 12	1
20	9501200	Highland	Hammock Storage Net	1
21	1970000	Highland	Cargo Bar 40 x 74"	2
22	1970200	Highland	Ratchet Cargo Bar	3
23	59000	ROLA	Move Organizer 25 x 15 x 7	1
24	59001	ROLA	Move Organizer 38 x 15 x 7	1
25	2004500	Highland	Pet Barrier	1
TOTAL CONTENTS				81
	37-2128		7' Tall x 4' Lozier Gondola	1
	37-2078		Pegboard 6" Hook, 50 pcs.	1

*NOTE: See GONDOLA DISPLAYS for gondola accessory items.

PLANOGRAM LAYOUTS



ROLA® / HIGHLAND® PLANOGRAM
Cequent Performance Products Merchandising Solutions

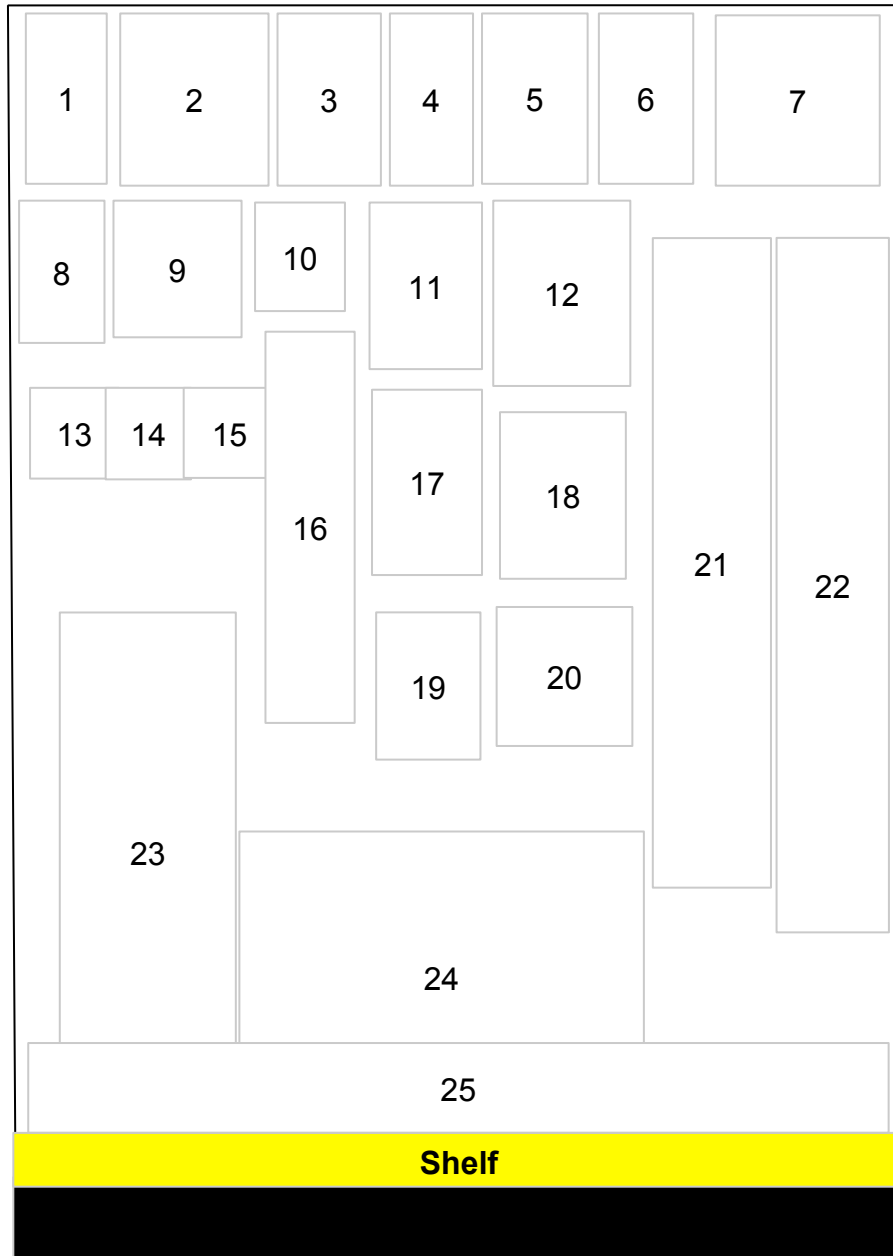



PRO SERIES™ / HIGHLAND® PLANOGRAM



Recommending a complete layout of the best selling Pro Series / Highland cargo management products.



Ref. No.	Part No.	Brand	Description	Qty
1	2004500	Highland	Universal Pet Barrier	1
2	1972000	Highland	Ratcheting Cargo Bar 40" to 70"	1
3	1038900	Highland	Cargo Carry Bag 15 cu. Ft. - rainproof	1
4	1038800	Highland	Bag Car Top Weather Resistant	1
5	1041700	Highland	Cargo Carrier Bag, Rainproof 13 cu. Ft.	1
6	9480000	Highland	Motorcycle Cover w/Storage Bag	1
7	9500900	Highland	Spare Tire Cover - 27" to 29"	2
8	9501400	Highland	Spare Tire Cover - 30" to 32"	1
9	9501300	Highland	3 Pocket Storage Net 48" to 60" x 133"	1
10	9500500	Highland	Cargo Net - Pickup Truck - 60" x 78"	2
11	9500100	Highland	Cargo Net 36" x 48"	2
12	9500600	Highland	Universal Heavy Duty Truck Net	2
13	3503600	Highland	Basket Carrier 49-1/2" x 37" x 7" - Black	1
14	2005200	Highland	Multi purpose Bar Carrier	1
15	1040300	Pro Series	Cargo Carrier w/3" Side Rails, 20" x 60" Platform, 2" Receiver Mount w 1-1/4" Adapter, Bolt Together	2
16	9480100	Highland	Car Cover w/Storage Bag	2
17	1039800	Highland	Expandable Roof Top Cargo Bag (10 to 15 cu. ft.)	1
TOTAL CONTENTS				23
	37-5365		4' Tall x 4' Lozier Gondola	1
	37-6666		Shelf 4' for Lozier Gondola	3

*NOTE: See GONDOLA DISPLAYS for gondola accessory items.

PLANOGRAM LAYOUTS



PRO SERIES™ / HIGHLAND® PLANOGRAM



Cequent Performance Products Merchandising Solutions

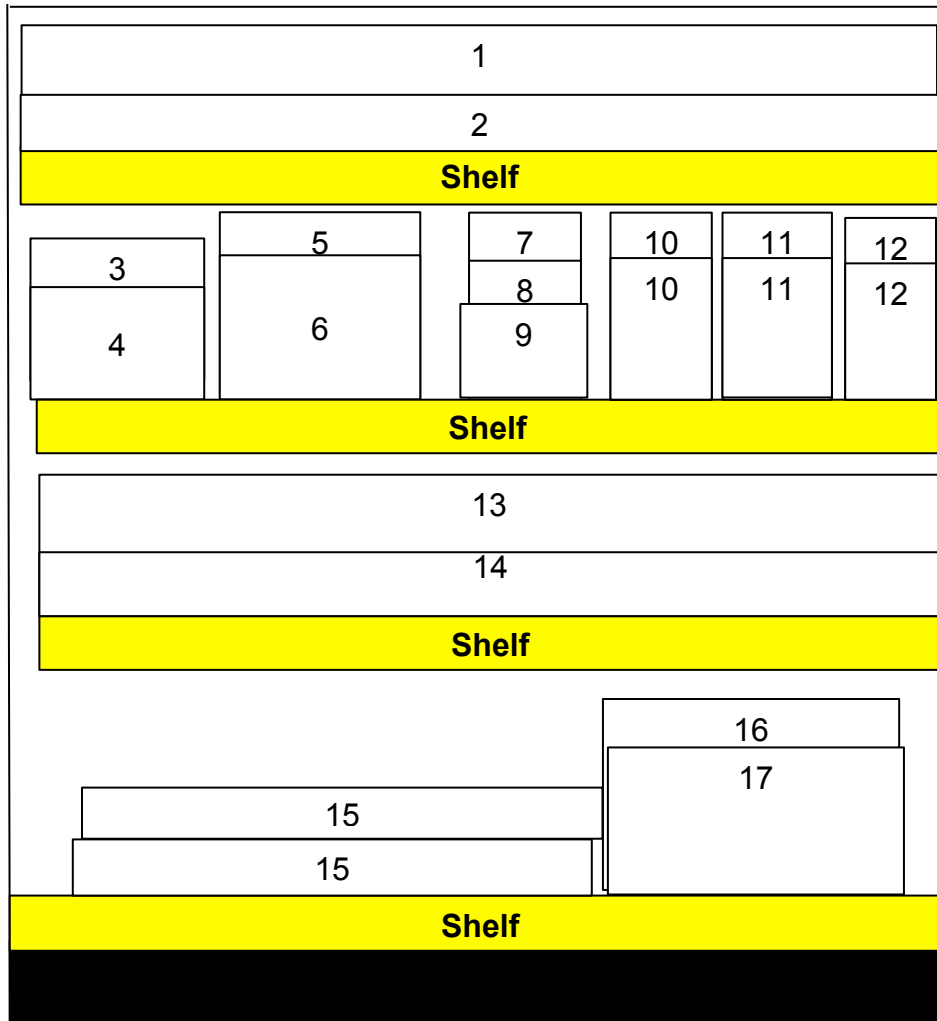



HIGHLAND® PLANOGRAM

Recommending a complete layout of the best selling Highland cargo management products.



Ref. No.	Part No.	Brand	Description	Qty
1	9210500	Highland	Ratchet Tie Down - 1" x 10' (4 pack)	2
2	9210600	Highland	Cambuckle Tie Down - 1" x 6', 900 lbs. - blue (4 pack)	2
3	1152200	Highland	Surelok Cambuckle Tie Down - 1' x 6'	2
4	9232400	Highland	Stretch Cord - 24" (2 pack)	3
5	1227000	Highland	Ratchet Tie Down - 1" x 10', 900 lbs. - Break Strength	3
6	9303200	Highland	Triple Strength Stretch Cord 32"	3
7	9304000	Highland	Triple Strength Stretch Cord 40"	3
8	9414500	Highland	Fat Strap Cord - 45"	3
9	1157100	Highland	Titan Ratchet Tie Down - 1" x 14', 1,800 lbs. (single)	2
10	1151800	Highland	Retractable Ratchet Tie Down - 1" x 6', 500 lbs. - twin pack	2
11	1034400	Highland	Cambuckle Tie Down w/hooks 1" x 12', 1,200 lbs. - black	2
12	1170500	Highland	Ratchet Tie Down - 1" x 14'	2
13	1158300	Highland	Titan Max Grip Ratchet Tie Down, 1" x 14', 3,000 lbs. (single)	2
14	1154201	Highland	Cambuckle Tie Down - 1" x 6', 1,300 lbs. - Break Strength - Orange	2
16	9203200	Highland	Stretch Cord - 32" (2 pack)	3
17	1169900	Highland	Ratchet Tie Down - 1" x 12'	3
18	1170000	Highland	Ratchet Tie Down - 1" x 13'	3
19	9302400	Highland	Triple Strength Stretch Cord 24"	3
20	9416700	Highland	Rotating Triple Strength Bungee Cord - 52"	3
21	9412000	Highland	Fat Strap Cord - 20"	3

Ref. No.	Part No.	Brand	Description	Qty
22	1157200	Highland	Titan Ratchet Tie Down - 1" x 14', 1,800 lbs. (2 pack)	2
23	1153500	Highland	Retractable Ratchet Tie Down - 1" x 6', 400 lbs. - Camo (2 pack)	2
24	1170200	Highland	Ratchet Tie Down - 1" x 6'	2
25	1158400	Highland	Titan Max Grip Ratchet Tie Down, 1" x 14', 3,000 lbs. (2 pack)	2
26	1152101	Highland	Ratchet w/Padded handle Tie Down - 1" x 6', 1,800 lbs. - Break Strength - Orange	2
27	9203200	Highland	Stretch Cord - 32" (2 pack)	3
28	1033300	Highland	Cambuckle Tie Down w/hooks 1" x 10', 900 lbs. - red	3
29	9305200	Highland	Triple Strength Stretch Cord 52"	3
30	9413000	Highland	Fat Strap Cord - 30"	3
31	9414900	Highland	Adjustable Fat Strap - 10" to 45" orange/black	3
32	1157300	Highland	Titan Ratchet Tie Down - 1" x 10', 1,800 lbs. (2 pack)	2
33	1158500	Highland	Titan Max Grip Ratchet Tie Down, 1" x 14', 3,000 lbs. (4 pack)	2
34	9500500	Highland	Cargo Net - Pickup Truck - 60" x 78"	1
35	9500100	Highland	Cargo Net - 36" x 48"	1
36	9008600	Highland	Bungee Cord Assortment - 24 pc.	1
37	9420500	Highland	Fat Strap Bungee Cords - 6 pc.	1
38	9133900	Highland	Tarp Strap Assortment - 6 pc.	1
39	9052000	Highland	Mini Stretch Cord Assortment - 20 pc.	1
TOTAL CONTENTS				81
	37-5365		4' Tall x 4' Lozier Gondola	1
	37-2078		Pegboard 6" Hook, 50 pcs.	1

*NOTE: See GONDOLA DISPLAYS for gondola accessory items.



HIGHLAND® PLANOGRAM

Cequent Performance Products Merchandising Solutions

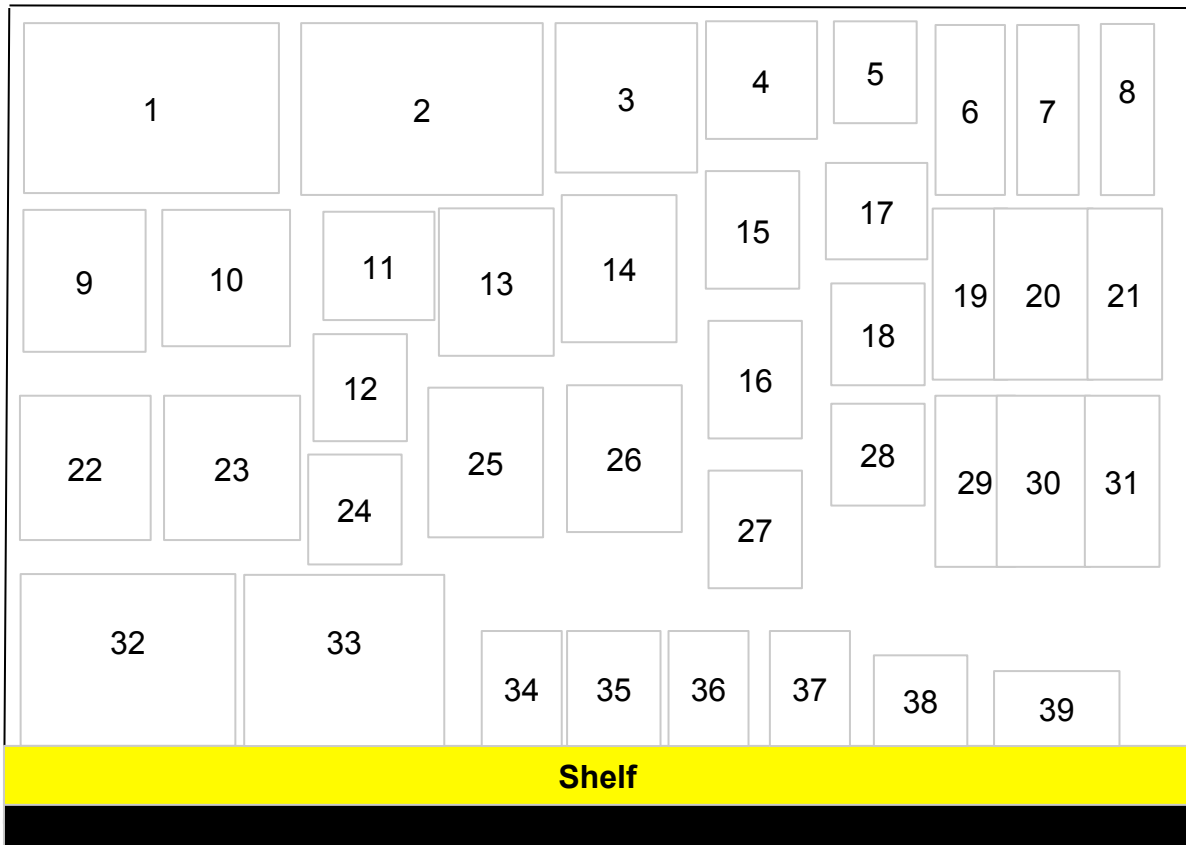

HOW WOULD YOU LIKE TO REDUCE THE COST OF YOUR HITCH INSTALLATION LIABILITY INSURANCE...

AND GET ADDITIONAL PROTECTION FREE?

DEALER SUPPORT

In the interest of safe towing, Draw-Tite, Hidden Hitch, and Reese® offers this Dealer Installation Indemnification Program. We're committed to designing and building the industry's highest quality trailer hitches and towing accessories. We also back our equipment with an extraordinary level of support for our customers.

Once enrolled in the Dealer Installation Indemnification Program, when you sell and properly install complete Draw-Tite, Hidden hitch, or Reese® products according to written instructions and provide your customers with the required information for safe and proper towing, you are indemnified on any claim over USD \$2,000 arising from your installation of Cequent branded products.*

INDEPENDENT OF THIS AGREEMENT, THE CEQUENT PERFORMANCE PRODUCTS INC. LIMITED LIFETIME WARRANTY REMAINS IN EFFECT WITH RESPECT TO PRODUCT CLAIMS.

DEALER BENEFITS

What you receive is the potential of significant cost savings by reducing your installation liability coverage for Cequent branded products. We design and build safety into everything we produce, so we have the confidence to back Cequent branded products with this comprehensive program. Therefore you'll be able to serve your customers with a new level of confidence, knowing Cequent backs your work. However, Cequent recommends you determine your base liability coverage requirements with your local insurance professional.

ELIGIBILITY

To qualify for the Dealer Installation Indemnification Program, you must be a qualified Draw-Tite, Hidden Hitch or Reese® Installer. If you install other manufacturers' products, you will need to maintain liability insurance to cover non Cequent branded products.

PROGRAM COST

There is no charge to the participating Dealer.

How The Program Works

1. Install Cequent Performance Products Inc. branded products properly, according to the instructions included.
2. Before installation begins, present the towing safety form (See important information on towing on the preceding pages) to the customer and have them read and sign it.
3. [A] Give the copy of the signed towing safety form to the customer.
[B] Retain the original signed towing safety form for you records.

To enroll in the program, contact your Sales Representative.

** For conditions and limitations see Dealer Agreement.*

LIMITED LIFETIME WARRANTY

- 1. Limited Lifetime Warranty ("Warranty"). Cequent Performance Products, Inc. ("We" or "Us") warrants to the original consumer purchaser only ("You") that the product will be free from material defects in both material and workmanship, ordinary wear and tear excepted; provided that installation and use of the product is in accordance with product instructions. There are no other warranties, express or implied, including the warranty of merchantability or fitness for a particular purpose. This warranty is not transferable.
- 2. Limitations on the Warranty. This Warranty does not cover: (a) normal wear and tear; (b) damage through abuse, neglect, misuse, or as a result of any accident or in any other manner; (c) damage from misapplication, overloading, or improper installation; (d) improper maintenance and repair; and (e) product alteration in any manner by anyone other than Us, with the sole exception of alterations made pursuant to product instructions and in a workmanlike manner.
- 3. Obligations of Purchaser. To make a Warranty claim, contact Us, at our principal address of 47774 Anchor Ct. W., Plymouth, MI 48170, 1-800-521-0510, identify the product by model number, and follow the claim instructions that will be provided. Any returned product that is replaced by Us becomes our property. You will be responsible for return shipping costs. Please retain your purchase receipt to verify date of purchase and that You are the original consumer purchaser. The product and the purchase receipt must be provided to Us in order to process Your Warranty claim.
- 4. Remedy Limits. Product replacement is Your sole remedy under this Warranty. We shall not be liable for service or labor charges incurred in removing or replacing a product or any incidental or consequential damages of any kind.
- 5. Assumption of Risk. You acknowledge and agree that any use of the product for any purpose other than the specified use(s) stated in the product instructions is at Your own risk.
- 6. Governing Law. This Warranty gives You specific legal rights, and You also may have other rights which vary from state to state. This Warranty is governed by the laws of the State of Michigan, without regard to rules pertaining to conflicts of law. The state courts located in Oakland County, Michigan shall have exclusive jurisdiction for any disputes relating to this Warranty.

LIMITED 1/3/5/7/10/15 YEAR WARRANTY

- 1. Limited Warranty. Cequent Performance Products, Inc. ("We" or "Us") warrants to the original consumer purchaser only ("You") that the product will be free from material defects in both material and workmanship for a specific period*, ordinary wear and tear excepted; provided that installation and use of the product is in accordance with product instructions. There are no other warranties, express or implied, including the warranty of merchantability or fitness for a particular purpose. If the product does not comply with this period specific limited warranty*, Your sole and exclusive remedy is that We will replace the product without charge to You and within a reasonable time or, at our option, refund the purchase price. This warranty is not transferable.
- 2. Limitations on the Warranty. This limited warranty does not cover: (a) normal wear and tear; (b) damage through abuse, neglect, misuse, or as a result of any accident or in any other manner; (c) damage from misapplication, overloading, or improper installation, including welds; (d) improper maintenance and repair; and (e) product alteration in any manner by anyone other than Us, with the sole exception of alterations made pursuant to product instructions and in a workmanlike manner.
- 3. Obligations of Purchaser. To make a warranty claim, contact Us, at our principal address of 47774 Anchor Ct. W., Plymouth, MI 48170, 1-800-521-0510, identify the product by model number, and follow the claim instructions that will be provided. Any returned product that is replaced or refunded by Us becomes our property. You will be responsible for return shipping costs. Please retain your purchase receipt to verify date of purchase and that You are the original consumer purchaser. The product and the purchase receipt must be provided to Us in order to process Your warranty claim.
- 4. Remedy Limits. Repair or replacement is Your sole remedy under this limited warranty or any other warranty related to the product. We shall not be liable for service or labor charges incurred in removing or replacing a product or any incidental or consequential damages of any kind.
- 5. Assumption of Risk. You acknowledge and agree that any use of the product for any purpose other than the specified use(s) stated in the product instructions is at Your own risk.
- 6. Governing Law. This limited warranty gives You specific legal rights, and You also may have other rights which vary from state to state. This limited warranty is governed by the laws of the State of Michigan, without regard to rules pertaining to conflicts of law. The state courts located in Oakland County, Michigan shall have exclusive jurisdiction for any disputes relating to this warranty.

*Visit www.cequentgroup.com for a copy of the specific warranty.

NUMERICALS

PART NO.	DESCRIPTION	PAGE #
000612	Bearing Protector, 2" Hub	M-20
001501	Grease Cap, 1.786" Zinc Plated	M-21
001503	Grease Cap, 1.786" Zinc Plated	M-21
001505	Grease Cap, 1.988" Zinc Plated	M-21
001508	Grease Cap, 2.251" Zinc Plated	M-21
001513	Grease Cap, 2.446"	M-21
001515	Grease Cap, 2.567" Zinc Plated	M-21
001516	Grease Cap, 3.008" Zinc Plated	M-21
001517	Grease Cap, 1.786" Zinc Plated	M-21
001518	Grease Cap, 1.988" Zinc Plated	M-21
001520	Grease Cap, 2.446" Zinc Plated	M-21
001523	Grease Cap, 1.943"	M-21
001524	Grease Cap, 1.943"	M-21
001526	Grease Cap, 2.722"	M-21
001527	Grease Cap, 1.957"	M-21
001528	Grease Cap, 3.358"	M-21
001531	Grease Cap, 3.157"	M-21
001601	Grease Cap, 2.333"	M-21
001602	Grease Cap, 3.255"	M-21
001603	Grease Cap, 3.882"	M-21
001604	Grease Cap, 2.446"	M-21
001605	Grease Cap, 2.722"	M-21
001606	Grease Cap, 2.503" Plain	M-21
001607	Grease Cap, 3.155"	M-21
001609	Grease Cap, 3.125"	M-21
001610	Grease Cap, 1.960"	M-21
001925	Grease Cap, 1.988" Zinc Plated	M-21
001926	Grease Cap, 2.333" Zinc Plated	M-21
001927	Grease Cap, 2.446" Zinc Plated	M-21
001928	Grease Cap, 1.786" Zinc Plated	M-21
002120	4-Flat Trailer End Connector, 20' Wunside Harness, 3' Ground	C-29
002125	4-Flat Trailer End Connector, 25' Wunside Harness, 3' Ground	C-29
002130	4-Flat Trailer End Connector, 30' Wunside Harness, 3' Ground	C-29
002215	4-Flat Trailer End Connector, 15' Wishbone Harness, 3' Ground	C-29
002220	4-Flat Trailer End Connector, 20' Wishbone Harness, 3' Ground	C-29
002230	4-Flat Trailer End Connector, 30' Wishbone Harness, 3' Ground	C-29
002235	4-Flat Trailer End Connector, 35' Wishbone Harness, 3' Ground	C-29
002240	4-Flat Trailer End Connector, 40' Wishbone Harness, 3' Ground	C-29
002275	5-Flat Trailer End Connector, 25' Wishbone Harness, 4' Ground, 5' Auxiliary	C-34
002280	5-Flat Trailer End Connector, 30' Wishbone Harness, 4' Ground, 5' Auxiliary	C-34
002285	5-Flat Trailer End Connector, 35' Wishbone Harness, 4' Ground, 5' Auxiliary	C-34
002290	5-Flat Trailer End Connector, 40' Wishbone Harness, 4' Ground, 5' Auxiliary	C-34
002301	4-Flat Car End Connector 48" Long, 18" Ground	C-29
002309	5-Flat Car End Connector, 6' Long, 6' Ground, 6' Auxiliary	C-34
002401	4-Flat Trailer End Connector, 18" Wunside Harness, 18" Ground	C-29
002402	4-Flat Trailer End Connector, 18" Wishbone Harness, 18" Ground	C-29
002408	Ag Economy Extension Harness, 5' Long	C-44, K-30
002409	5-Flat Trailer End Connector, 4' Wishbone Harness, 4' Ground, 4' Auxiliary	C-34
002410	Ag Economy Extension Harness, 10' Long	C-44, K-30
002415	Ag Straight Section Harness w/ 7-Pin Ag Plug and 4-Flat, 15' Long	C-44, K-30
002425	Ag Straight Section Harness w/ 7-Pin Ag Plug and 4-Flat, 25' Long	C-44, K-30
002430	Ag Straight Section Harness w/ 7-Pin Ag Plug and 4-Flat, 30' Long	C-44, K-30
002500	Ag Tandem Haul Adapter	C-44, K-30
002504	Ag Economy Rear Wishbone Harness, 10' Long	C-44, K-30
002505	Ag Economy Rear Wishbone Harness, 15' Long	C-44, K-30
002510	Ag Heavy-Duty Wishbone Harness w/Protective Covering, 10' Long	C-44, K-30
002515	Ag Heavy-Duty Rear Wishbone Harness w/Protective Covering, 15' Long	C-44, K-30

PART NO.	DESCRIPTION	PAGE #
002590	Magnet Kit for Ag Lights, 90 lbs. Pull (Set of 4)	C-44, K-30
002625	Ag Tandem Haul Kit	C-44, K-30
002670	Ag Economy Light Kit	C-46, K-28
002675	Ag Deluxe Transport Kit w/ Brake Light Function, 6-Pin	C-46, K-28
002676	Ag Deluxe Transport Kit w/ Brake Light Function, 7-Pin	C-46, K-28
002802	Metal Wire Clip (1000 pack)	C-56
002804	Wire Nut, Small - 16-18 Gauge (1000 pack)	C-56
002805	Wire Nut, Large - 14-16 Gauge (1000 pack)	C-56
002806	Wire Tap, White, Double Leads (500 pack)	C-56
002807	Wire Tap, Blue, Single Leads (500 pack)	C-56
002808	Butt Connector, Blue, 14-16 gauge	C-56
003101	Side Marker/Clearance Light Amber w/Reflex Lens w/Black Stud-Mount Base	K-43
003103	Side Marker/Clearance Light Red w/Reflex Lens w/Black Stud-Mount Base	K-43
003121	Side Marker/Clearance Light Amber w/Reflex Lens w/Black Ear-Mount Base	K-43
003123	Side Marker/Clearance Light Red w/Reflex Lens w/Black Ear-Mount Base	K-43
0031350300	A-Frame Bottom Support Plate, 2.3" Hole Dia., for 150's, 160's, 170's & A-Frames	J-8, J-25
003141	Side Marker/Clearance Light Amber w/Reflex Lens, PC Rated	K-44
003148	Side Marker/Clearance Light Amber w/Reflex Lens, PC Rated	K-44
0031550300	Weld-On Female Mount, 3/4" Pin for 190's	J-8
003201	License Plate Bracket, Plastic, Black	K-53
003202	License Plate Bracket, Plastic, White	K-53
003211	License Plate Bracket, Plastic, Black	K-53
003213	License Plate Bracket, Plastic, White	K-53
003225	Side Marker/Clearance Light Amber, PC Rated	K-44
003230	Side Marker/Clearance Light Amber w/White Stud-Mount Base, PC Rated	K-39
003231	Side Marker/Clearance Light Red w/White Stud-Mount Base, PC Rated	K-39
003232	Courtesy Light w/Self-Grounding Stud Mount, Single Wire w/ Molded Barrel	K-26
003238	Side Marker/Clearance Light, Amber, Waterproof, Black, Stud Mount, PC Rated	K-39
003239	Side Marker/Clearance Light, Red, Waterproof, Black, Stud Mount, PC Rated	K-39
003240	Lens, Side Marker - Amber (lens only)	K-42
003243	Side Marker/Clearance Base (only) w/ Ground Strap, White	K-42
003272	Side Marker/Clearance Light Amber w/White Ear-Mount Base, PC Rated	K-39
003273	Side Marker/Clearance Light Red w/White Ear-Mount Base, PC Rated	K-39
003301	ID Bar, Standard, Amber	K-50
003305	ID Bar-SS, Waterproof (w/White Bases), Red	K-49
003306	ID Bar-SS, Waterproof (w/Black Bases), Red	K-49
003308	Sealed Bulb Capsule	K-22
003309	ID Bar, Red, "15 Series" Waterproof	K-49
003310	ID Bar, Economy w/Black Bar, Red	K-50
003318	Lens, Amber, Side Marker/Clearance Light	K-44
003327	Clearance Light Replacement Lens Red	K-43
003328	Clearance Light Replacement Lens Amber	K-43
003330	Clearance Light Replacement Lens Amber	K-44
003337	Lens, Red, Side Marker/Clearance Light w/Screw	K-43
003338	Lens, Amber, Side Marker/Clearance Light w/Screw	K-43
003340	Lens, Amber, Side Marker/Clearance, Square	K-44
003357	Amber Reflector w/Adhesive Back (1/bag)	K-55
003358	Red Reflector w/Adhesive Back (1/bag)	K-55
003378	Lens, Amber Clearance w/ Reflex (Rectangle)	K-42
003387	White Reflector w/Adhesive Back, 1"x1" (2/bag)	K-55
003388	Red Reflector w/Adhesive Back, 1"x1" (2/bag)	K-55
003440	Side Marker/Clearance Light, Amber, w/Dual Bulbs	K-47
003441	Side Marker/Clearance Light, Red, w/Dual Bulbs	K-47
003494	Lens Amber, Clearance Light	K-47
003495	Lens Red, Clearance Light	K-47

NUMERICALS

PART NO.	DESCRIPTION	PAGE #
0050050300	Weld-On Male Mount, 9/16" Pin	J-8
0050240300	Weld-On Female Tube Mount, 5/8" Pin for 190's	J-8
005122	Weld-On Tube Mount for #182524 & #182374	J-8, J-16
005164	Weld-On Tube Mount 5/8	J-8
006504	Tail Light 8-Function, Waterproof Over 80" Low Profile w/ Stripped Leads - Left/Roadside	K-22
006554	Tail Light 7-Function, Waterproof Over 80" Low Profile w/ Stripped Leads - Right/Curbside	K-22
007257	7-Way Blade to 5-Flat, 6" Wire Adapter	C-47
007509	Trailer Light Kit w/25' Harness, Waterproof Low-Profile Wrap-Around Over 80"	K-22
007539	Trailer Light Kit w/25' Harness, Waterproof Over 80" Low Profile	K-22
008540	Plastic Fender, 8"-12" Tire Size, White	M-22
008541	Plastic Fender, 8"-12" Tire Size, White	M-22
008543	Plastic Fender, 13" Tire Size, White	M-22
008549	Plastic Fender, 8"-12" Tire Size, White	M-22
008550	Plastic Fender, 8"-12" Tire Size, Black	M-22
008551	Plastic Fender, 8"-12" Tire Size, Black	M-22
008553	Plastic Fender, 13" Tire Size, Black	M-22
008554	Plastic Fender, 14" Tire Size, Black	M-22
008559	Plastic Fender, 8"-12" Tire Size, Black	M-22
008561	Plastic Fender, 8"-12" Tire Size, Silver	M-22
008563	Plastic Fender, 13" Tire Size, Silver	M-22
008564	Plastic Fender, 14" Tire Size, Silver	M-22
008569	Plastic Fender, 8"-12" Tire Size, Silver	M-22
008572	Plastic Fender, 12" Tire Size, White	M-22
008573	Plastic Fender, 13" Tire Size, White	M-22
008574	Plastic Fender, 14" Tire Size, White	M-22
008575	Plastic Fender, 15" Tire Size, White	M-22
008582	Plastic Fender, 12" Tire Size, Black	M-22
008583	Plastic Fender, 13" Tire Size, Black	M-22
008584	Plastic Fender, 14" Tire Size, Black	M-22
008585	Plastic Fender, 15" Tire Size, Black	M-22
008592	Plastic Fender, 12" Tire Size, Silver	M-22
008593	Plastic Fender, 13" Tire Size, Silver	M-22
008594	Plastic Fender, 14" Tire Size, Silver	M-22
008595	Plastic Fender, 15" Tire Size, Silver	M-22
01202-024	Receiver Tube Covers, 2" Sq., Black (24 pack)	B-21
0133301S00	Replacement Part, Ratchet Paw for F2 Winch	J-62
0133302S00	Service Kit, Pinion Shaft -XLT14	J-62
0133303S01	Service Kit, Pinion Shaft -T1602, T1801	J-62
0133306S01	Service Kit, Ratchet Repair - T1100, T1300, T1500	J-62
015181	Sidewind Crank Assembly for 180's	J-16, J-27
0152710300	Bracket-Female Swivel-2.5" O.D.	J-8
0152730300	Weld-On Male Swivel Mount, 9/16" Pin for 150's & 170's	J-8
0152790300	Weld-On Male Swivel Mount, 5/8" Pin, 2" O.D. for 170's	J-8
017125	Detachable Steel Wheel Assembly w/Pin for 150 A-Frame's	J-8, J-25
018098	Tongue Jack Support Foot, Removable w/Lock Pin, 6.2" Tall, Rating 2,000 - 5,000 lbs. for Jacks w/2" Inner Tubes	J-8, J-26
018507	Kit -Removable Caster Assembly Steel Wheel	J-25
0185640301	Removable Disc Foot w/Pin 2.1" Tall - Plated for 150's & 170's	J-26
01932-003	3/8" Drill Bits (3 pack)	O-3
01933-003	7/16" Drill Bits (3 pack)	O-3
01934-003	1/2" Drill Bits (3 pack)	O-3
01938-003	1/4" Pilot Drill Bits (3 pack)	O-3
0233010300	Kit, Adjustable Tube - Welded 20" w/Pin Hole & 1 Set Bolt	J-42
0233050300	ADJ. TUBE-WLD-30" W/PIN	J-42
0233060301	Replacement Part, Pin Kit for Adjustable Gooseneck Coupler	J-42
0233100300	BX1 Kit, Adjustable Round Tube - Welded 20" w/Pin Hole & 2 Set Bolts	J-42
024200	High Profile Coupler Repair Kit	J-38
024202	Kit, Adjustable Height Coupler Mounting Hardware	J-40
028242	Coupler, Round Tube Mount, 5000 lbs.	J-38
028243	Coupler, Square/Rectangler Mount, 7000 lbs.	J-38
028244	Coupler, Square/Rectangler Mount, 5000 lbs.	J-38

PART NO.	DESCRIPTION	PAGE #
028287	Coupler, A-Frame Mount, 7000 lbs.	J-38
028288	Coupler, A-Frame Mount, 5000 lbs.	J-38
028351	Hitch Ball, 2" Dia. x 1" Shank, 5000 lbs.	B-4
028352	Hitch Ball, 2" Dia. x 1" Shank, 7000 lbs.	B-4
028375	Hitch Ball, 2" Dia. x 3/4" Shank, 3000 lbs.	B-4
028381	Coupler, Round Tube Mount, 5000 lbs.	J-38
028382	Coupler, Ball Size 2", Tongue Mount Width 3", Straight Channel, 5,000 lbs.	J-38
028383	Coupler, Round Straight Mount, 5000 lbs.	J-38
028384	Coupler, Ball Size 2", A-Frame Coupler, 5,000 lbs.	J-38
028386	Coupler, Ball Size 2", A-Frame Coupler, 7,000 lbs.	J-38
028387	Coupler, Ball Size 2", Tongue Mount Width 3", Straight Channel, 7,000 lbs.	J-38
028390	Adjustable Coupler, 7000 lbs.	J-38
028400	Hitch Ball, 2-5/16" Ball x 1-1/4" Shank, 12,500 lbs.	B-4
028442	Coupler, Round Tube Mount, 12,500 lbs.	J-38
028444	Coupler, Square/Rectangler Mount, 12,500 lbs.	J-38
028461	Coupler, Round Tube Mount, 12,500 lbs.	J-38
028462	Coupler, Ball Size 2-5/16", Tongue Mount Width 3", Straight Channel, 12,500 lbs.	J-38
028463	Coupler, Ball Size 2-5/16", A-Frame Coupler, 12,500 lbs.	J-38
028499	Coupler, A-Frame Mount, 12,500 lbs.	J-38
028630	Adjustable Coupler, 12,500 lbs.	J-38
028655	5B8L CPLR L/BALL	J-38
028656	5B8H CPLR L/BALL	J-38
0287600300	20K Adjustable Gooseneck Coupler	J-42
0287610300	20K Adjustable Gooseneck Coupler w/Pin & Less Outer Tube	J-42
0287690300	20K Fixed Base Gooseneck Coupler	J-42
0287740300	20K Gooseneck Coupler Kit, Includes Locking Pin Assembly, Locking Pin Cover and Labels	J-42
0287790300	COUPLER-GSNK-PRO SERIES 20K	J-44
0287800300	COUPLER-GSNK-PRO SERIES 25K	J-44
0287820300	25K Round Gooseneck Coupler, Includes Locking Pin Assembly, Single Set Bolt, 4 Hole Adjustment and Labels	J-44
028900	30K Adjustable Square Gooseneck	J-42
0289250300	25K Adjustable Round Gooseneck w/Pin & Outer Tube	J-42
0289500300	30K Adjustable Round Gooseneck w/Pin	J-42
0289580300	25K Round King Pin Gooseneck	J-42
0289590300	30K Square King Pin Gooseneck	J-42
0289600300	25K Square Gooseneck w/Pin	J-42
0289640300	25K Round King Pin Gooseneck w/o Outer Tube, 4 Hole	J-42
0289650300	30K Square King Pin Gooseneck w/o Outer Tube, 4 Hole	J-42
0289800300	30K Square Gooseneck w/Pin	J-42
0289SB0140	ADJ GOOSENECK PINCH BOLT KIT	J-42
05102-100	6-5/8" All Weather Beaded Cable Ties, White (100 pack)	C-56
05330-010	Hitch Hider Tube Covers, 2" Sq. Receivers w/Built-In 4-Flat Electrical Cover (10 pack)	B-21
06237	1/2" Hitch Pin for 1-1/4" Class I and Class II, Zinc	B-17
07010-024	Receiver Tube Cover, 2" Sq., Black Rubber (24 pack)	B-21
0917501S00	Wheel Replacement - Plain w/UPC	J-25
0917514-00	CAP-JACK 2.25 EXPANDED	J-35
0917540-00	CAP - 2 JACK TUBE	J-35
0933301S00	Service Kit, Handle-Marine JK 800 lbs.	J-35
0933302S00	Service Kit, Bevel	J-35
0933305S00	Service Kit, Handle-Sidewind Jacks	J-35
0933306S00	Service Kit, Bevel Gear-1200 lbs. Jacks	J-35
0933307S00	Service Kit, Plunger Pin 1/2" S-Mount	J-35
0933325S00	Service Kit, Bolt-On Hardware	J-35
1000750	Water Wick, 750 Gram	M-30
101469	4-Flat Car End Connector 72" Long, 72" Ground (Includes Wire Taps)	C-29
1017600	Tow Strap w/Hooks - 2" x 20', 10,000 lbs.	I-37
1017800	Tow Strap w/Loops - 2" x 20', 17,000 lbs.	I-37
1024	Accelerated Battery Charging Device (ABCD)	M-6
1026	Shur-Set III® Breakaway System w/5 Amp/Hr Battery (Includes #2005 Breakaway Switch) (Battery Charger Sold Separately)	M-5

NUMERICALS

PART NO.	DESCRIPTION	PAGE #
102639	Lens Red, Clearance/Side Marker	K-22
102641	Lens Red, Taillight Over 80"	K-22
1028	Shur-Set III® Breakaway System w/5 Amp/Hr Battery(with ABCD) (Includes #2005 Breakaway Switch)	M-5
1033300	Cambuckle Tie Down w/Hooks - 1" x 10', 900 lbs., Red	I-35
1034200	Motorcycle Tie Down - 1" x 6'	I-35
1034400	Cambuckle Tie Down - 1" x 12', 1200 lbs. - Black	I-35
1038800	Roof Top Waterproof Cargo Bag (10 cubic ft.) - 38" x 38" x 18"	I-28
1038900	Roof Top Waterproof Cargo Bag (15 cubic ft.) - 37" x 30" x 16"	I-28
1039700	Cargo Carrier Bag, Rainproof (20 cubic ft.)	I-28
1039800	Expandable Roof Top Cargo Bag (10 to 15 cubic ft.)	I-28
1040000	Packer™ Cargo Carrier w/2-1/2" Side Rails, 20" x 60" Platform, 2" Receiver Mount, Bolt Together	I-22
1040100	Solo™ Cargo Carrier w/3" Side Rails, 32" x 48" Platform, 2" Receiver Mount, Bolt Together	I-25
1040200	Cargo Carrier Accessory, Loading Ramp for #1040100	I-25
1040300	Packer™ 2 Cargo Carrier w/2-1/2" Side Rails, 20" x 60" Platform, 2" Receiver Mount w/1-1/4" Adapter, Includes 1/2" & 5/8" Pins & Clips, Bolt Together	I-22
1041700	Cargo Carrier Bag, Rainproof (13 cubic ft.)	I-28
1043500	Interior Cargo Guard™ (38 cubic ft.) - 51" x 44" x 28"	I-29
104429	Plastic Wire Clip w/ Adhesive Back	C-56
106205	Mounting Bracket, 6" Oval Tail Light	K-8, K-10/11, K-21, K-26
106289	Clearance Light Base, Chrome 2" Snap-Lock, Self-Grounding	K-26, K-32, K-37
106293	Clearance Light Base, Chrome 2" Snap-Lock, Open-Back	K-26, K-32, K-37
106294	Module, Utility, Snap-lock, Clear	K-26, K-32, K-37
106310	Single Plug for Snap-lock Base	K-54
106334	Pigtail	K-37
106410	TAIL LP LO PRO LH O-80	K-22
106411	TAIL LP LO PRO RH O-80	K-22
106873	6" Oval Mounting Bracket	K-8, K-10/11, K-21, K-26
108060	Ag Light Enhanced Lighting Module w/ Wire Leads	C-44, K-30
108284	Lens Red, Light Bar	K-50
108297	Base only, Black, Open Back "15 Series"	K-26, K-32, K-37
108318	Ag Light Enhanced Lighting Module w/ Molded Plugs	C-44, K-30
108319	Ag Light Enhanced Lighting Module w/ Weatherproof Plugs	C-44, K-30
108663	Plug, 2-Way, 18" w/#10 Ring	K-26, K-31/32, K-34, K-37/38, K-54
108820	4-Flat Trailer End Connector, 20' Wishbone Harness, 30" Ground	C-29
108825	4-Flat Trailer End Connector, 25' Wishbone Harness, 30" Ground	C-29
108830	4-Flat Trailer End Connector, 30' Wishbone Harness, 30" Ground	C-29
108835	4-Flat Trailer End Connector, 35' Wishbone Harness, 30" Ground	C-29
108840	4-Flat Trailer End Connector, 40' Wishbone Harness, 30" Ground	C-29
108843	Lens Amber, Clearance Light	K-47
108844	Lens Red, Clearance Light	K-47
108891	Bulb #193	K-67
109356	Trailer Light Kit w/15' Trailer Harness	K-18
109992	Ag Light Enhanced Lighting Module w/ Brake Light Signal Function w/ Wire Leads	C-44, K-30
11003	Receiver Extension, 2" to 2" Extension, 14" Length, 4000 lbs. WC & 6500 lbs. WD	B-13
11004	Receiver Extension, 2" to 2" Extension, 18" Length, 4000 lbs. WC & 6500 lbs. WD	B-13
11005	Receiver Extension w/Step, 2" to 2" Extension, 14" Length, 4000 lbs. WC & 6500 lbs. WD	B-13
11006	Receiver Extension w/Step, 2" to 2" Extension, 18" Length, 4000 lbs. WC & 6500 lbs. WD	B-13
11029	Receiver Fabrication Part, 18" Combo Bar 2-1/2" Sq. ID, Unpainted	A-16
11081	Receiver Fabrication Part, 8" Combo Bar 2" Sq. ID, Unpainted	A-16
11200 0101	Coupler, Class I, 1-7/8" Ball, 2" Channel, 2000 lbs. - Zinc	J-48
11200 0317	Coupler, Class I, 1-7/8" Ball, 2" Channel, 2000 lbs. - Primed	J-48

PART NO.	DESCRIPTION	PAGE #
1120500	69" Straight Aluminum Loading Ramp, 1250 lbs. Capacity (625 lbs. per Ramp)	I-38, N-3
1120800	Ramp, Aluminum Bi-Fold 15" x 69", 1400 lbs. (Pair)	I-38, N-3
1121300	Ramp, Aluminum Arched Centerfold 12" x 85", 700 lbs. (Single)	I-38, N-3
1121400	Ramp, Aluminum Tri-Fold 45" x 69", 1600 lbs. (Single)	I-38, N-3
1121500	Ramp, Aluminum Tri-Fold 54" x 77", 1600 lbs. (Single)	I-38, N-3
1122600	Ramp, Aluminum Tri-Fold 11" x 80", 800 lbs. (Single)	I-38, N-3
1123000	Ramp, 69" Straight Steel Loading Ramp, 600 lbs. Capacity (Single)	I-38, N-3
1123100	Arched Aluminum Center-Fold Loading Ramp, 1500 lbs. Capacity (750 lbs. Per Ramp) (Sold As Pair)	I-38, N-3
1124	Hole Saw Arbor w/Pilot Drill for #1123	O-3
11250 0317	Coupler, Class I, 1-7/8" Ball, 2-1/2" Channel, 2000 lbs. - Primed	J-48
11300 0101	Coupler, Class I, 1-7/8" Ball, 3" Channel, 2000 lbs. - Zinc	J-48
11300 0317	Coupler, Class I, 1-7/8" Ball, 3" Channel, 2000 lbs. - Primed	J-48
1150601	Cambuckle Tie Down - 2" x 6', 2500 lbs. - Yellow	I-35
1151601	Ratchet Tie Down - 1-1/4" x 10', 3,300 lbs. - Break Strength	I-35
1151701	Ratchet Tie Down - 1-1/2" x 15', 5,500 lbs. - Break Strength	I-35
1151801	Retractable Ratchet Tie Down - 1" x 6', 500 lbs. (2 pack)	I-35
1152101	Ratchet w/Padded Handle Tie Down - 1" x 6', 1,800 lbs. - Break Strength - Orange	I-35
1152201	SureLok Cambuckle Tie Down - 1" x 6'	I-35
1152301	Ratchet Tie Down - 1" x 6', 1,500 lbs. - Break Strength - Camo	I-35
1152401	Cambuckle Tie Down - 1" x 6', 1,200 lbs. - Break Strength - Camo	I-35
1152500	HD Ratchet Tie Down - 2" x 25', 10,000 lbs. - Break Strength	I-35
1153500	Retractable Ratchet Tie Down - 1" x 6', 400 lbs., Camo (2 pack)	I-35
1154000	Retractable Ratchet Tie Down - 2" x 10', 1100 lbs. (Single)	I-35
1154201	Cambuckle Tie Down - 1" x 6', 1,300 lbs. - Break Strength - Orange	I-35
1156201	SureLok Tie Down - 6'	I-35
1157100	Titan Ratchet Tie Down, 1" x 14', 1800 lbs. (Single)	I-33
1157200	Titan Ratchet Tie Down, 1" x 6', 1800 lbs. (2 pack)	I-33
1157300	Titan Ratchet Tie Down, 1" x 10', 1800 lbs. (4 pack)	I-33
1158300	Titan Max Grip Ratchet Tie Down, 1" x 14', 3000 lbs. (Single)	I-33
1158400	Titan Max Grip Ratchet Tie Down, 1" x 14', 3000 lbs. (2 pack)	I-33
1158500	Titan Max Grip Ratchet Tie Down, 1" x 14', 3000 lbs. (4 pack)	I-33
1160400	ATV Ratchet Tie Down w/Reflective Webbing - 1" x 12' (4 pack)	I-35
116437	ARTWORK DT	P-4
116438	ARTWORK BD	P-4
1169900	Ratchet Tie Down - 1" x 12'	I-35
1170000	Ratchet Tie Down - 1" x 13'	I-35
1170200	Ratchet Tie Down - 1" x 6'	I-35
1170500	Ratchet Tie Down - 14'	I-35
117398	STAND RV JACK DISPLAY	P-4
117399	ENDCAPS (3) MARINE JACK	P-4
117400	ENDCAPS (4) RV JACK DISP	P-4
11748	Hitch Ball Grease - 4 Oz. Tube	O-3
11755	Electrical Contact Grease, 2 Oz. Tube	C-57
118001	4-Flat Car End Connector 48" Long (Includes 4 Wire Taps)	C-30
118001-024	4-Flat Car End Connector 48" Long (24 pack)	C-30
118001-200	4-Flat Car End Connector 48" Long (200 pack)	C-30
118002	4-Flat Car End Connector 60" Long (Includes 4 Wire Taps)	C-30
118002-024	4-Flat Car End Connector 60" Long (24 pack)	C-30
118002-200	4-Flat Car End Connector 60" Long (200 pack)	C-30
118004	4-Flat Trailer End Connector, 12" Long	C-30
118004-012	4-Flat Trailer End Connector, 12" Long (12 pack)	C-30
118009	4-Flat Trailer End Connector, 21" Long	C-30
118015	7-Way U.S. Car Replacement Socket for 7-Way OEM Ford, GM & Nissan Vehicles	C-4
118016	5-Flat 72" Car End Wiring Harness	C-34
118016-025	5-Flat 72" Car End Wiring Harness (25 pack)	C-34
118017	5-Flat 48" Trailer End Wiring Harness	C-34
118019	7-Way to Cigarette Lighter Plug Adapter	C-48
118020	7-Way Flat Pin Connector, Car End, Plastic	C-37
118020-006	7-Way Flat Pin Connector, Car End, Plastic (6 pack)	C-37

NUMERICALS

PART NO.	DESCRIPTION	PAGE #
118020-050	7-Way Flat Pin Connector, Car End, Plastic (50 pack)	C-37
118021	7-Way Flat Pin Connector, Trailer End, Plastic	C-37
118021-006	7-Way Flat Pin Connector, Trailer End, Plastic (6 pack)	C-37
118021-050	7-Way Flat Pin Connector, Trailer End, Plastic (50 pack)	C-37
118022	2-Flat Electrical Connector Loop, 12" Long	C-32
118031	7-Way Flat Pin Connector, Trailer End, Metal	C-37
118032	4-Flat to 4-Flat Universal Adapter	C-48
118033	4-Flat Trailer End Connector, 48" Long	C-30
118033-012	4-Flat Trailer End Connector, 48" Long (12 pack)	C-30
118036	6-Way Round Pin Connector, Car End, Metal	C-35
118036-006	6-Way Round Pin Connector, Car End, Metal (6 pack)	C-35
118036-050	6-Way Round Pin Connector, Car End, Metal (50 pack)	C-35
118037	6-Way Round Pin Connector, Trailer End, Metal	C-35
118037-006	6-Way Round Pin Connector, Trailer End, Metal (6 pack)	C-35
118037-050	6-Way Round Pin Connector, Trailer End, Metal (50 pack)	C-35
118043	4-Flat Car End Connector 30" Long, "The Knockout" Connector	C-31
118044	4-Flat Plug Loop, 48" Long (Includes 4 Wire Taps)	C-30
118044-010	4-Flat Plug Loop, 48" Long (10 pack)	C-30
118044-175	4-Flat Plug Loop, 48" Long (175 pack)	C-30
118045	4-Flat Plug Loop, 60" Long (Includes 4 Wire Taps)	C-30
118045-010	4-Flat Plug Loop, 60" Long (10 pack)	C-30
118045-175	4-Flat Plug Loop, 60" Long (175 pack)	C-30
118077	4-Way Round Connector, Car and Trailer End, Metal	C-31
118101	4-Way Round Connector, Car End, Metal	C-31
118102	4-Way Round Connector, Trailer End, Metal	C-31
118104	4-Flat Trailer End Connector to 6 Pole Square Adapter for Jayco Type Trailers	C-35
118132	Mounting Bracket Combo for 4-Way & 6-Way Round Connectors	C-51
118136	Universal Mounting Bracket and Clamp (Long)	C-52
118137	Mounting Bracket for 4, 5 and 6-Way Connectors, Includes Screws and Nuts	C-52
118137-010	Mounting Bracket for 4, 5 and 6-Way Connectors (10 pack)	C-52
118138	Mounting Bracket for 7-Way Flat Pin Connectors, Includes Screws and Nuts	C-52
118138-010	Mounting Bracket for 7-Way Flat Pin Connectors (10 pack)	C-52
118140	Universal Mounting Bracket and Clamp (Short)	C-52
118144	4-Flat Mounting Bracket	C-52
118144-010	4-Flat Mounting Bracket (10 pack)	C-52
118145	Plug Storage Box for 4-Flat Connector	C-53
118147-025	Cover w/Lead Tester, 4-Flat Connector	C-33
118149	4-Flat Universal Mounting Bracket	C-51
118151	Wiring Kit for Installing #118146, #118176, #118187 & #118190 ModuLite® Power Modules, Includes 20 ft. Undercar Wire, Fuse w/Holder and Attaching Terminals	C-25
118152	Trailer Plug Holder for 6 & 7-Way Trailer Plugs	C-53
118156	6 & 7-Way Connector Mounting Box, 2-1/2" Crosstubes	C-54
118156-010	6 & 7-Way Connector Mounting Box, 2-1/2" Crosstubes (10 pack)	C-54
118157	6 & 7-Way Connector Mounting Box, 3" Crosstubes	C-54
118157-010	6 & 7-Way Connector Mounting Box, 3" Crosstubes (10 pack)	C-54
118158	2 to 3 Taillight Converter for Connecting Tow Vehicles w/2 Wire Systems to Towed Vehicles w/3 Wire Systems	C-27
118159	6 & 7-Way Connector Mounting Box, Universal for Round & Square Tube Hitches	C-54
118159-010	6 & 7-Way Connector Mounting Box, Universal for Round & Square Tube Hitches (10 pack)	C-54
118172-024	4-Flat Car End Connector 72" Long (24 pack)	C-30
118172-150	4-Flat Car End Connector 72" Long (150 pack)	C-30
118185	4-Flat Plug Loop, 18" Long (Includes 4 Wire Taps)	C-30
118185-025	4-Flat Plug Loop, 18" Long (25 pack)	C-30
118185-200	4-Flat Plug Loop, 18" Long (200 pack)	C-30
118192	4-Flat Trailer End Connector, Dual Tail Light Wires, 25' Long	C-30
118215	5-Flat Plug Loop 60" Long, Car & Trailer End Wiring Harness	C-34
118601	4-Flat to 4-Flat "The Knockout" Adapter	C-48
118603	4-Flat Car End Connector 60" Long, "The Knockout" Connector	C-31
118607	Pre-Wired Brake Mate™ Kit Adapter, 7-Way Flat Pin Connector w/Brake Control Wiring Installation Kit	C-50, H-11

PART NO.	DESCRIPTION	PAGE #
118615-020	4-Flat Plug Loop, 72" Long (20 pack)	C-30
118630	Side Post Universal Battery Bolt Extender, 1-3/4" Short Side Terminal	C-56
118631	Side Post Universal Battery Bolt Extender, 1-3/16" Long Side Terminal	C-56
118634	Tap/Ground Kit Side Post Universal Battery Plate w/Spade Terminal Tabs & 16-22 Gauge Female Terminals	C-56
118636	4-Flat Plug Loop, 24' Long (Includes 4 Wire Taps)	C-30
118664	7-Way U.S. Car End to 7-Way Trailer End Extension Cable 7'	C-39
118665	Battery Isolation Solenoid, 3 Pole, 12 Volt (Chassis Ground)	N-7
118666	6-Way Car End to 6-Way Trailer End Extension Cable 7'	C-39
118700	6-Way Round Pin to 4-Flat Adapter	C-48
118700-050	6-Way Round Pin to 4-Flat Adapter (50 pack)	C-48
118702	7-Way Flat Pin to 4-Flat Adapter	C-48
118702-050	7-Way Flat Pin to 4-Flat Adapter (50 pack)	C-48
118703	7-Way Flat Pin to 5-Flat Adapter	C-48
118704	7-Way Flat Pin to 6-Way Round Adapter w/Electric Brakes to Outside (S) Pin of 6-Way	C-48
118704-050	7-Way Flat Pin to 6-Way Round Adapter w/Electric Brakes to Outside (S) Pin of 6-Way (50 pack)	C-48
118708	7-Way Flat Pin to 6-Way Round Adapter w/Electric Brakes to Center (A) Pin of 6-Way	C-48
118708-050	7-Way Flat Pin to 6-Way Round Adapter w/Electric Brakes to Center (A) Pin of 6-Way (50 pack)	C-48
118709	7-Way Round Pin to 4-Flat Adapter	C-48
118799	Pre-Wired Adapter, 7-Way Flat Pin Connector w/Brake Control Wiring	C-50
118821	Taillight Isolating System w/4-Flat	C-27
119130	Taillight Converter w/12" Leads and 60" 4-Flat Car End Connector	C-27
119130-012	Taillight Converter w/12" Leads and 60" 4-Flat Car End Connector (12 pack)	C-27
119130-050	Taillight Converter w/12" Leads and 60" 4-Flat Car End Connector (50 pack)	C-27
119146	ModuLite® Trailer Light Power Module	C-24
119146-012	ModuLite® Trailer Light Power Module (12 pack)	C-24
119146-050	ModuLite® Trailer Light Power Module (50 pack)	C-24
119175	Taillight Converter with Integrated Circuit Protection	C-27
119175-012	Taillight Converter with Integrated Circuit Protection (12 pack)	C-27
119175-050	Taillight Converter with Integrated Circuit Protection (50 pack)	C-27
119176	ModuLite® Protector w/Integrated Circuit Protection	C-24
119176-012	ModuLite® Protector w/Integrated Circuit Protection (12 pack)	C-24
119176-050	ModuLite® Protector w/Integrated Circuit Protection (50 pack)	C-24
119177	ModuLite® Protector w/Integrated Circuit & Overload Protection & 5-Flat Connector for Backup Light or Surge Brake Lockout Circuit	C-26
119186	ModuLite® Protector w/Integrated Circuit Protection & Installation Kit	C-24
119190	ModuLite® HD Protector w/Integrated Circuit & Overload Protection Trailer Light Power Module	C-25
119190-012	ModuLite® HD Protector w/Integrated Circuit & Overload Protection Trailer Light Power Module (12 pack)	C-25
119190-050	ModuLite® HD Protector w/Integrated Circuit & Overload Protection Trailer Light Power Module (50 pack)	C-25
119191	ModuLite® HD Protector w/Integrated Circuit & Overload Protection Trailer Light Power Module & Installation Kit	C-25
119192	ModuLite® Ultra Protector w/Integrated Circuit & Overload Protection Trailer Light Power Module	C-26
1202	Receiver Tube Cover, 2" Sq., Black	B-21
1227000	Ratchet Tie Down - 1" x 10', 900 lbs. - Break Strength	I-35
1240	Inside Bed Tire Carrier	M-27
1270700	Ratchet Tie Down - 1-1/2" x 7', 6,000 lbs. - Break Strength	I-37
1272700	Ratchet Tie Down - 2" x 27'	I-35
1275000	Tire Tie Down - 9', 6000 lbs. - Break Strength	I-37
1275500	Tire Tie Down - 25', 6000 lbs. - Break Strength	I-37
1289000300	BX1 25K Round Gooseneck Coupler, Includes Locking Pin Assembly, Dual Set Bolts, 4 Hole Adjustment and Labels	J-43
1289020300	BX1 25K Round Gooseneck Coupler w/o Outer Tube, Includes Locking Pin Assembly, 4 Hole Adjustment and Labels	J-43
1340000	Pocket-Lok - Universal Anchoring System, Chrome	N-4

NUMERICALS

PART NO.	DESCRIPTION	PAGE #
1370100	SportWing™ Steel Bike Carrier, 2 Bike, 1-1/4" Sq. Receiver Mount	I-11
1370300	Shank Adapter, Permits Use of 1-1/4" Accessories in 2" Receivers	I-14
1370400	SportWing™ Aluminum Bike Carrier, 4 Bike, 2" Sq. Receiver Mount	I-11
1370500	SportWing™ Steel Bike Carrier, 4 Bike, 2" Sq. Receiver Mount	I-11
1370600	Pro Series™ AXIS 3™, Bike Carrier, 3 Bike, Dual Arm, Trunk Mount	I-14
1370800	SportWing™ Accessory Shank, 1-1/4" Sq. Receiver Mount w/4" Rise, Includes Pin & Clip	I-11
1400300303	Pro Series™ Bolt-On Jack, Topwind, 2,000 lbs. w/Footplate	J-10
1400400303	Pro Series™ Weld-On Jack, Topwind, 10" Travel, 2,000 lbs. w/Footplate	J-10
1400600303	Pro Series™ A-Frame Jack, 5,000 lbs.	J-9
1400700340	Pro Series™ Footplate & Pin	J-9
1400750340	6" Caster, Poly	J-9
1400800383	Pro Series™ Square Tube, 8,000 lbs., Topwind, 15" Travel, Adjustable Dropleg w/Additional Travel of 13.6"	J-19
1400830383	Pro Series™ Weld-On Square Tube, 8,000 lbs., Topwind, Tubular Swivel Mount w/Footplate, 10" Travel	J-19
1400850383	Pro Series™ Square Tube, 8,000 lbs., Sidewind, 15" Travel, Adjustable Dropleg w/Additional Travel of 13.6"	J-19
1400860383	Pro Series™ Weld-On Square Tube, 8,000 lbs., Sidewind, Tubular Swivel Mount w/Footplate, 10" Travel	J-19
1400920383	KIT-JACK HNDL W/MNT HDWR	J-19
1400950376	Pro Series™ Weld-On Jack Square Tube, 12,000 lbs., Sidewind, 12-1/2" Travel, Adjustable Dropleg w/Spring Return & Additional Travel of 13-1/2", Crank Handle Included	J-19
140094	Pro Series™ Weld-On Jack Square Tube, 12,000 lbs., Sidewind, 12-1/2" Travel, Adjustable Dropleg w/Additional Travel of 13-1/2"	J-19
1400960376	Pro Series™ Weld-On Jack Square Tube, 12,000 lbs., Sidewind, 12-1/2" Travel, Adjustable Dropleg w/Spring Return & Additional Travel of 13-1/2"	J-19
1400980376	Pro Series™ Weld-On Jack Square Tube, 12,000 lbs., Sidewind, 12-1/2" Travel, Adjustable Dropleg w/Additional Travel of 13-1/2", Crank Handle Included	J-19
1400990376	Pro Series™ Weld-On Jack Square Tube, 12,000 lbs., Sidewind, 12-1/2" Travel, Adjustable Dropleg w/Additional Travel of 13-1/2"	J-19
1401000303	Pro Series A-Frame Jack, 2,000 lbs.	J-9
1401010376	Pro Series™ Weld-On Jack Square Tube, 12,000 lbs., Sidewind, 12-1/2" Travel, Adjustable Dropleg w/Additional Travel of 13-1/2"	J-19
1401020303	Pro Series™ Weld-On Jack, Sidewind, 2,000 lbs. w/Footplate	J-10
1401030303	Pro Series Weld-On Jack, Sidewind, 2,000 lbs. w/Footplate	J-10
1401040303	Pro Series™ Weld-On Jack, Topwind, 2,000 lbs. w/Footplate	J-10
1401060303	Pro Series™ Weld-On Jack, Sidewind, 2,000 lbs. w/Footplate	J-10
1401080303	Pro Series™ Weld-On Jack, Sidewind, 2,000 lbs. w/Footplate	J-10
1401140303	Pro Series™ Weld-On Jack, Topwind, 2,000 lbs. w/Footplate	J-10
1401200303	Pro Series™ Weld-On Jack, Topwind, 2,000 lbs. w/Footplate	J-10
1401420303	Pro Series™ Weld-On Jack, Sidewind, 5,000 lbs.	J-10
1401440303	Pro Series™ Weld-On Jack, Sidewind, 5,000 lbs. w/Footplate	J-10
1401460303	Pro Series™ Weld-On Jack, Topwind, 5,000 lbs.	J-10
1401480303	Pro Series™ Weld-On Jack, Topwind, 5,000 lbs. w/Footplate	J-10
1401500383	Pro Series™ Square Tube, 5,000 lbs., Topwind, 15" Travel, Adjustable Dropleg w/Additional Travel of 13.6"	J-19
1401520383	Pro Series™ Square Tube, 5,000 lbs., Topwind, Weld-On Tubular Swivel Mount w/Footplate, 10" Travel	J-19
1401600383	Pro Series™ Square Tube, 5,000 lbs., Sidewind, 15" Travel, Adjustable Dropleg w/Additional Travel of 13.6"	J-19
1401610383	Pro Series™ Square Tube, 5,000 lbs., Sidewind, Weld-On Tubular Swivel Mount w/Footplate, 10" Travel	J-19
1410050149	400 lbs., Trailer Stand, Swivel, 6" Poly Wheel	J-34
1411300301	Jack, 1500 lbs., Bolt-On, Independent Caster, Torsion Axle Version	J-34
1413020134	F2 Jack, 1600 lbs., Twin Track	J-29
1413040134	F2 Jack, 1600 lbs., Wide Track	J-29
1413050334	F2 Jack, 1600 lbs., Wide Track, includes Handle Holdup, Weld-On Mount, & Mounting Hardware	J-29
1413060334	F2 Jack, 1600 lbs., Twin Track, Weld-On	J-29
1413080334	F2 Jack, 1600 lbs., Twin Track, Bolt-On	J-29
1413110334	F2 JACK WIDE TRACK WELD-ON BULK/25 OEM 4 X 5	J-29

PART NO.	DESCRIPTION	PAGE #
1413120334	F2 JACK TWIN TRACK WELD-ON BULK/25 OEM 4 X 5	J-29
1413130334	F2 JACK-TWN TRK OE-5 U--BOLT	J-29
1413140334	F2 JACK-WIDE TRK OE-5 U--BOLT	J-29
1413200334	F2 Jack, 2000 lbs., Swivel w/Foot Plate, Weld-On	J-30
1413210334	F2 JACK-2K SWWL W.FT BOLT-ON	J-30
1413220334	F2 Jack, 2000 lbs., Swivel w/Foot Plate, Bolt-On	J-30
1413230134	F2 Jack, 2000 lbs., Swivel w/Foot Plate, Bolt-On	J-30
1413250334	F2 Jack, RV A-Frame	J-31
1420	Adjustable Ball Mount Assembly, 12" Length, 5,000 lbs. (GTW), 500 lbs. (TW)	B-11
1422	Adjustable Ball Mount Assembly, 14" Length, 5,000 lbs. (GTW), 500 lbs. (TW)	B-11
1424	Adjustable Ball Mount Assembly, 16" Length, 5,000 lbs. (GTW), 500 lbs. (TW)	B-11
14-715810	7-Way Junction Box	C-54
148700	Multi-Jack w/Foot Plate, 7,000 lbs. Capacity, 35" Travel	J-36
150000	Jack, Topwind, 10" Travel, No Mount or Base, 2000 lbs. Lift Capacity	J-7
150152	Jack, Sidewind, 15" Travel, No Mount, 2000 lbs. Lift Capacity	J-7
150441	TWS 150DTSFX w/P&C PLTD	J-6
151101	Weld-On Jack, Sidewind, 10" Travel, Weld-On "L" Bend Swivel Bracket, 2,000 lbs. Lift Capacity (Includes Base)	J-7
1511180301	Bolt-On Jack, Sidewind, 15" Travel, Fixed Mount Bracket, 2,000 lbs. Lift Capacity	J-7
151159	Weld-On Jack, Sidewind, 15" Travel, Weld-On "L" Bend Swivel Bracket, 2,000 lbs. Lift Capacity (Includes Base)	J-7
151401	Weld-On Jack, Topwind, 10" Travel, Weld-On "L" Bend Swivel Bracket, 2,000 lbs. Lift Capacity (Includes Base)	J-7
151421	Bulldog Tongue Jack, Swivel Jack, Topwind, 15" Travel, Weld-On Retaining Ring Bracket, Rating 2,000 lbs.	J-7
151443	Bolt-On Jack, Topwind, 10" Travel, Bolt-On Swivel Bracket, 2,000 lbs. Lift Capacity	J-7
151460	TWS 151 DS Jack	J-7
1514S01	Service Kit-One Way Ratchet Repair -T600, T600L, T900-Models Pre-2007	J-62
1542S01	Replacement Part, Repair Kit (GN24), Includes Torsion Spring, Coupler Locking Shaft, Curved Handle Assembly, 3/4" Shaft Retaining Ring, Centerlock Nut - 1/2-13	J-42
1550100317	A-Frame Jack, Sidewind, 13" Travel, 14.5" Bracket to Ground Retracted, 3,000 lbs. Lift Capacity	J-6
1550101344	A-Frame Jack, Sidewind, 13" Travel, 14.5" Bracket to Ground Retracted, 3,000 lbs. Lift Capacity	J-6
155022	A-Frame Jack, Topwind, 15" Travel, 8.4" Bracket to Ground Retracted, Weld-On/Bolt-On, 2,000 lbs. Lift Capacity	J-6
155028	A-Frame Jack, Topwind, 8.4" Bracket to Ground Retracted, 2,000 lbs. Lift Cap., - Zinc Plated	J-6
155032	A-Frame Jack, Topwind, 15" Travel, 10.15" Bracket to Ground Retracted, Weld-On/Bolt-On, 5,000 lbs. Lift Capacity	J-6
155033	A-Frame Jack, Topwind, 15" Travel, Weld-On/Bolt-On, 2,000 lbs. Lift Capacity	J-6
155157	A-Frame Jack, Sidewind, 13" Travel, 8.6" Bracket to Ground Retracted, Weld-On/Bolt-On, 2,000 lbs. Lift Capacity	J-6
1558S00	Service Kit, Friction Disc - K/KX1550	J-62
1562S00	Service Kit, Ratchet Repair, 2-Speed- T2005, T2605(B), T2625, T3205	J-62
1563S01	Service Kit, Pinion Shaft - K/KX1550	J-62
1565S01	Service Kit, Pinion Shaft/Gear - K2550	J-62
1568S01	Service Kit, Inter Shaft - K2550	J-62
1570S00	Service Kit, Friction/Brake Disc -K/KX1051	J-62
158109	Swivel Jack, Sidewind, 10" Travel, Weld-On Tubular Mount, 2,000 lbs. Lift Capacity (Includes Foot Plate)	J-6
158151	Swivel Jack, Sidewind, 15" Travel, Weld-On Tubular Mount, 2,000 lbs. Lift Capacity (Includes Foot Plate)	J-6
158451	Swivel Jack, Topwind, 10" Travel, Weld-On Tubular Mount, 2,000 lbs. Lift Capacity (Includes Foot Plate)	J-6
158452	Swivel Jack, Topwind, 15" Travel, Weld-On Tubular Mount, 2,000 lbs. Lift Capacity (Includes Foot Plate)	J-6
158488	TWL 150 DTSF w/P&C-w/Mount	J-6
1591	Fastener Assortment	A-16
1592	Hook, Hitch Rack	P-2
1598S01	Service Kit, Ratchet Repair - T1602, T1801, T903Z, P1200	J-62

NUMERICALS

PART NO.	DESCRIPTION	PAGE #
1609S01	Service Kit-Input Shaft/Bearing -T2005, T2605(B), T2625, T3205	J-62
161100	161D JACK ASSEMBLY	J-24
161300	161W JACK ASSEMBLY	J-24
1619-01	BRAKE KIT TWO SPEED	J-62
162300	162 W JACK W/L-BOLT KIT	J-24
165111	165D JACK ASSEMBLY (BOLT-ON)	J-24
165211	165R JACK ASSEMBLY (BOLT-ON)	J-24
165311	165 W, 16" Travel, Includes #018155 Gearbox and #018006 Rack & Post Assembly	J-24
165411	HD 165 W JACK ASM (BOLT-ON)	J-24
165412	HD 165 W JACK ASM-21 BOLT-ON	J-24
169201	169 R JACK ASM W/MTG BRKT-BLK	J-24
1700100317	A-Frame Jack, Sidewind, 15" Travel, Weld-On/Bolt-On, 5,000 lbs. Lift Capacity	J-6
1701480317	TWL 170 X, 5,000 lbs. Lift Cap., 15" Travel, No Mount	J-7
170205	SWL 170, 5,000 lbs. Lift Cap., 15" Travel, Less Base, No Mount	J-7
171401	Weld-On Jack, Topwind, 10" Travel, Weld-On "L" Bend Swivel Bracket, 5,000 lbs. Lift Capacity (Includes Base)	J-7
171412	Weld-On Jack, Topwind, 15" Travel, Weld-On "L" Bend Swivel Bracket, 5,000 lbs. Lift Capacity (Includes Base)	J-7
1750290301	TWL 175 X JACK	J-6
1750290317	TWL 175 X A-Frame, 5,000 lbs. Lift Cap.	J-6
178101	Swivel Jack, Topwind, 10" Travel, Weld-On Tubular Mount, 5,000 lbs. Lift Capacity (Includes Foot Plate)	J-6
178151	Swivel Jack, Topwind, 15" Travel, Weld-On Tubular Mount, 5,000 lbs. Lift Capacity (Includes Foot Plate)	J-6
178201	Swivel Jack, Sidewind, 10" Travel, Weld-On Tubular Mount, 5,000 lbs. Lift Capacity (Includes Foot Plate)	J-6
178203	Swivel Jack, Sidewind, 15" Travel, Weld-On Tubular Mount, 5,000 lbs. Lift Capacity (Includes Foot Plate)	J-6
18004001	4-Flat Trailer End Connector, 12" Long	C-29
180304	TWS 180 DL-BQ, 10,000 lbs. Support Cap., 10" Travel, 10.12" ADDT'L ADJ., Crank, No Mount	J-14
18035	4-Strand 18 Gauge Bonded Wire, 500' Spool	C-55
180354	TWL 180 DL-BQ, 10,000 lbs. Support Cap., 15" Travel, 13.50" ADDT'L ADJ., Crank, No Mount	J-14
18044001	4-Flat Loop, 48" Long (Includes Wire Taps)	C-29
18045001	4-Flat Loop, 60" Long (Includes Wire Taps)	C-29
180455	SWL 180 DL-BQ, 10,000 lbs. Support Cap., 15" Travel, 13.50" ADDT'L ADJ., Crank, No Mount	J-14
18099-025	In-Line Fuse Holder Wire Taps, for 20 Amp Bayonet Fuse (25 pack)	C-55
18121-100	Non-Insulated Ring Terminal, 10-12 Gauge Wire, #10 Stud Size (100 pack)	C-56
18148	Tow Light Kit - Includes 2 Magnetic Base Lights and Leads	K-19
18164-020	1/4" Diameter Shrink Tube, 8" Length (20 pack)	C-56
18167-010	In-Line 20 Amp Fuse Holder with Protective Cover (10 pack)	C-55
18185001	4-Flat Loop, 18" Long (Includes Wire Taps)	C-29
18191	7 Conductor Trailer Wire, (3) 12 ga., (4) 14 ga., 250' Spool	C-55
182300	TWQ 180 DL-B Less Crank (800075)	J-15
182304	TWQ 180 DL-BC, w/Crank (800075) Attached	J-15
1823050383	JACK-SWQ FL-LX-W/O	J-20
1823060383	JACK-SWQ FL-LX-W/O	J-20
182400	SWQ 180 DL-B Less Crank	J-15
182404	12,000 lbs. - Sidewind Heavy Duty Square Jack - 12-1/2" Travel	J-15
182411	SWQ 180 DL-B Less Crank - Pin to the Curb	J-15
182415	SWQ 180 DL BX Less Crank - Pin to the Front	J-15
1824180100	Electric Powered Kit - 12K 2-Speed	J-18
1824200100	Electric Powered Kit - 12K	J-18
1824210100	Electric Powered Kit - 12K	J-18
182500	SWQ 180 FL-B Less Crank	J-15
182524	SWQ 180 TS-FL-BX w/Crank (015181)	J-16
182800	SWQ 180 DL-B-SR Less Crank	J-16
182804	SWQ 180 DL-BC-SR w/Crank (015181) Attached	J-16
182805	SWQ 180 DL-BX w/SR, Less Crank - Pin To The Curb - Companion Jack	J-16
182815	SWQ 180 DL BX SR Less Crank - Pin To The Front	J-16
183401	SWQ 183 DL-BX Pin To The Side, 2-Speed	J-17

PART NO.	DESCRIPTION	PAGE #
183416	SWQ 183 DL-BX Pin To The Front, 2-Speed	J-17
183816	SWQ 183 DL-BX Spring Return - Pin To The Front, 2-Speed	J-17
183900	SWQ 183 DL-B 2SPD-T JACK	J-17
183901	SWQ 180 DL-BX T Pin To Front, 2-Speed	J-17
183902	SWQ 180 DL-B T Spring Return - Pin To Side, 2-Speed	J-17
183903	SWQ 180 DL-BX T Spring Return - Pin To Front, 2-Speed	J-17
1839050383	JACK-SWQ FL-LX-W/O-2 SPD	J-20
1839060383	JACK-SWQ FL-LX-B/O-2 SPD	J-20
190704	TWL 190 DL-BQ, 8,000 lbs. Support Cap., 15" Travel, Drop Leg, No Mount	J-13
190705	TWS 190 FL-BTSMQ w/P&C, 8,000 lbs. Support Cap., 10" Travel, Fixed Leg, w/Male Mount	J-13
190706	TWL 190 FL-BTSMQ w/P&C, 8,000 lbs. Support Cap., 15" Travel, Fixed Leg, w/Male Mount	J-13
190708	TWL 190 DL-BTSMQ W/P&C	J-13
190754	SWL 190 DL-BQ, 8,000 lbs. Support Cap., 15" Travel, Drop Leg, No Mount	J-13
190756	SWL 190 FL-BTSMQ w/P&C, 8,000 lbs. Support Cap., 15" Travel, Fixed Leg, w/Male Mount	J-13
190758	SWL 190 DL-BTSMQ w/P&C, 8,000 lbs. Support Cap., 15" Travel, Drop Leg, w/Male Mount	J-13
19306	1" High Rise, 2-5/16" Ball for Under-Bed Gooseneck Heads (Do Not Store Inverted In Head)	G-11
19307	3" Ball for Under-bed Gooseneck Heads (Do Not Store Inverted In Head)	G-11
19308	5" Offset Extension, 2-5/16" Ball for Under-bed Gooseneck Heads (Do Not Store Inverted In Head)	G-11
19309	Replacement Part, 2-5/16" Ball for Hide-A-Goose #9460, #9461, #9464 & Under-Bed Gooseneck #9470, #9471, #9474 Heads Only	G-11
19311	Replacement Part, 2-5/16" Pop-In™ Ball for Elite™ Under-Bed Bolt-On Gooseneck Head	G-6
19314	3" Pop-In™ Ball for Elite™ Under-Bed Bolt-On Gooseneck Head	G-6
19315	1" High Rise, 2-5/16" Pop-In™ Ball for Elite™ Under-Bed Bolt-On Gooseneck Head	G-6
1935	Drill Bit Set, (1) 3/8", (1) 7/16", (1) 1/2"	O-3
1936	Hole Saw, 1"	O-3
1937	Hole Saw Arbor w/Pilot Drill	O-3
1944	Receiver Tube Cover, 2" Sq., Chrome Plastic	B-21
195301	TWL 195 DQ JACK	J-12
195304	TWL 195 DL-DXQ, 5,000 lbs. Support Cap., 15" Travel, No Mount, O.T. Gray, I.T. Zinc, Drop Leg	J-12
195306	TWL 195 DTSFQ w/P&C, 5,000 lbs. Support Cap., 15" Travel, Round Mount, O.T. Gray, I.T. Zinc	J-12
195312	TWL 195 DTSXFQ w/P&C, 5,000 lbs. Support Cap., 15" Travel, Square Mount, O.T. Gray, I.T. Zinc	J-12
195318	TWL 195 DL-DFXQ, 5,000 lbs. Support Cap., 15" Travel, A-Frame Mount, O.T. Gray, I.T. Zinc, Drop Leg	J-12
195319	TWL 195 FL-BXQ, 5,000 lbs. Support Cap., 15" Travel, No Mount, O.T. Gray, I.T. Zinc, Caster Base	J-12
195320	TWL 195 FL-XQ, 5,000 lbs. Support Cap., 15" Travel, No Mount, O.T. Gray, I.T. Zinc, No Base	J-12
195321	TWL 195 FL-FXQ JACK	J-12
195322	TWL 195 DL-DFXQ JACK	J-12
195352	SWL 195 DQ JACK ASM	J-12
195354	SWL 195 DL-DXQ, 5,000 lbs. Support Cap., 15" Travel, No Mount, O.T. Gray, I.T. Zinc, Drop Leg	J-12
195356	SWL 195 DTSFQ w/P&C, 5,000 lbs. Support Cap., 15" Travel, Round Mount, O.T. Gray, I.T. Zinc	J-12
195362	SWL 195 DTSXFQ w/P&C, 5,000 lbs. Support Cap., 15" Travel, Square Mount, O.T. Gray, I.T. Zinc	J-12
195368	SWL 195 FL-XQ, 5,000 lbs. Support Cap., 15" Travel, No Mount, O.T. Gray, I.T. Zinc, Caster Base	J-12
195369	SWL 195 FL-XQ JACK	J-12
1962	Safety Chain Loop, Class II/III, 5,000 lbs.	A-16
1970000	Cargo Bar 40" to 74"	I-30
1970200	Ratcheting Cargo Bar 40" to 70"	I-30
198100	Swivel Jack, Topwind, 10" Travel, Weld-On Tubular Mount, 7,000 lbs. Lift Capacity (Includes Foot Plate)	J-6
198150	Swivel Jack, Sidewind, 10" Travel, Weld-On Tubular Mount, 7,000 lbs. Lift Capacity (Includes Foot Plate)	J-6

NUMERICALS

PART NO.	DESCRIPTION	PAGE #
198200	Swivel Jack, Topwind, 15" Travel, Weld-On Tubular Mount, 7,000 lbs. Lift Capacity (Includes Foot Plate)	J-6
1982200	Turbo Truck Cab Interior Organizer	I-30
198250	Swivel Jack, Sidewind, 15" Travel, Weld-On Tubular Mount, 7,000 lbs. Lift Capacity (Includes Foot Plate)	J-6
20000	Lockable Battery Case (Plastic) with Partition for Shur-Set III™	M-6
20005	Shur-Set III® All Polymer Lockable Breakaway System (Includes #2010 Nylon Breakaway Switch)	M-5
20006-010	30 Amp Maxi Fuse (10 pack)	C-55
20010	Shur-Set III® Lockable Breakaway System (Includes #2010 Nylon Breakaway Switch)	M-5
20015	Shur-Set III® All Polymer Lockable Breakaway System (with Charger) (Includes #2010 Nylon Breakaway Switch)	M-5
20020	Shur-Set III® Lockable Breakaway System (with Charger) (Includes #2010 Nylon Breakaway Switch)	M-5
20034-025	Perm-A-Seal Butt Connectors, 14-16 Gauge, Blue (25 pack)	C-56
20035-025	Perm-A-Seal Butt Connectors, 10-12 Gauge, Yellow (25 pack)	C-56
2004500	Universal Pet Barrier	I-30
20046	Mounting Bracket for 5-Flat Connectors	C-52
20047	7-Way U.S. Car Replacement Socket for 7-Way Twist In OEM GM Vehicles	C-4
20048	Breakaway Kit for 1 to 2 Axle Trailers w/Electric Brakes, Includes Battery Box, 5 Amp Battery w/LED Test Meter, Battery Charger and Breakaway Switch	M-4
20049-050	Replacement Part, Light Kit Harness For Railed Cargo Carrier Part DT #40100, DT #40101, RL #59502, RS #15100, RS #15101, TR #63152, TR #63153	I-20, I-22
2005-A	Replacement Cable and Brass Pin assembly for #2005 Switch	M-6
2005-B120	Breakaway Switch, 1-3 Axle	M-6
2005-P	Replacement Part, Breakaway Switch, 1-3 Axle	M-6
2009-A	Replacement Cable and Brass Pin Assembly for #2009 Switch	M-6
2009-A-P	Replacement Cable and Brass Pin Assembly for #2009 Switch	M-6
2009-B60	Breakaway Switch, Metal	M-6
2009-P	Breakaway Switch, Metal	M-6
2010-A	Replacement Cable and Nylon Pin Assembly for #2010 Switch	M-6
2010-A-P	Replacement Cable and Nylon Pin Assembly for #2010 Switch	M-6
2010-B125	Breakaway Switch, Nylon w/ Weldable Tab	M-6
2010-P	Breakaway Switch, Nylon w/ Weldable Tab	M-6
20110	Fifth Wheel Adapter Harness, 7-Way Flat Pin U.S. Car Connector Assembly 7 ft., GM, Ford, Dodge, Toyota	C-40/42
20111	Fifth Wheel Adapter Harness, 7-Way Flat Pin U.S. Car Connector Assembly 7 ft., Dodge	C-40/42
20112	Cover, 4-Flat LED Connector	C-33
20112-024	Cover, 4-Flat LED Connector (24 pack)	C-33
20113	Fifth Wheel Adapter Harness, 7-Way Flat Pin U.S. Car Connector Assembly 7 ft., Toyota	C-40/42
20114	4-Flat Car End Tester w/LED Display	O-2
20115	5-Flat Car End Tester w/ LED Display and Dust Cap	O-2
20116	6-Way Car End Tester w/LED Display	O-2
20117	7-Way Flat Pin Car End Tester w/LED Display	O-2
20118	Cover, 5-Flat Connector	C-33
20118-024	Cover, 5-Flat Connector (24 pack)	C-33
20119	Multi-Plug T-One Connector Assembly, 7-Way Flat Pin Connector/4-Flat Combo Adapter Harness for 7-Way U.S. Car Replacement Socket for 7-Way OEM Ford, GM & Nissan Vehicles	C-4
20125	4-Flat to 7-Way Flat Pin U.S. Car Connector Adapter	C-50
20127	Universal 12" Brake Control Plug for #5520 (Activator® III), #20185 (Intella-Stop™ Ultra), #20188 (Intella Stop™ Digital), #39515 (Primus™), #39519 (Prodigy®), #39526 (P3®), #83520 (Brakeman™ Ultra)	H-10
20128	4-Flat (OEM) to 6 Way Connector Assembly 7 ft.	C-40/42
20129	4-Flat (OEM) to 6 Way Connector Assembly 7 ft.	C-40/42
20130	4-Flat (OEM) to 7 Way Connector Assembly 7 ft.	C-40/42
20131	4-Flat (OEM) to 7 Way Connector Assembly 7 ft.	C-40/42
20135	Multi-Plug T-One Connector Assembly, 7-Way Flat Pin Connector/4-Flat Combo Adapter Harness for 7-Way U.S. Car Replacement Socket for 7-Way OEM Chrysler, Dodge, Freightliner, Jeep & Mitsubishi Vehicles	C-4
20136	4-Flat to 5-Flat Connector Assembly	C-48

PART NO.	DESCRIPTION	PAGE #
20137	Multi-Plug T-One Connector Assembly, 7-Way Flat Pin Connector/4-Flat Combo Adapter Harness for 7-Way U.S. Car Replacement Socket for 7-Way OEM Lexus & Toyota Vehicles	C-4
20140	Fifth Wheel Adapter Harness, 7-Way Flat Pin U.S. Car Connector Assembly 7 ft. w/Pigtails for Choice of Hardwiring 6 or 7-Way Connector, GM, Ford, Dodge, Toyota	C-40/42
20143	6-Way Round Pin Connector/4-Flat Combo Adapter Harness w/ Mounting Bracket & Hardware	C-47
20144	7-Way Flat Pin Connector/4-Flat Combo Adapter Harness w/ Mounting Bracket & Hardware	C-47
20174	Light Kit For Railed Cargo Carrier Part #59108, #59109, #59110, #59502, #59507, #59550, #63152, #63153, #63154, #63155, #38174	I-24
2018	Post Mount Battery Box (Plastic) with Partition for Shur-Set III™ (Includes Mounting Bracket)	M-6
20191	I-Stop™ IQ Electronic Brake Control, for 1 to 3 Axle Trailers, Proportional	H-7
20212	Mounting Bracket for 7-Way OEM Connectors, Includes Screws and Nuts	C-52
20212-010	Mounting Bracket for 7-Way OEM Connectors (10 pack)	C-52
20223	7-Way Trailer Wiring Harness, U.S. Car Connector, 7'	C-40
20224	7-Way Trailer Wiring Harness, U.S. Car Connector, 4'	C-40
2023	12 Volt 5 Amp/Hr Sealed Lead Acid Battery for Shur-Set III™	M-6
2023-X	12 Volt 5 Amp/Hr Sealed Lead Acid Battery for Shur-Set III™	M-6
2024-07	DC to DC Heavy Duty Quick/Maintenance (Multi Stage) Charger - 12 Volt	M-6
2024-07-S	DC to DC Heavy Duty Quick/Maintenance (Multi Stage) Charger - 12 Volt	M-6
20250	4-Flat Wiring Kit, Contains 12" 16 ga. for Vehicles w/Factory Wiring Harness w/o Plug	C-28
2025-09	AC-CHGR 5 AMP BATTERY	M-6
20251	4-Flat Wiring Kit w/Taillight Converter, Contains 72" 16 ga. Car End Connector Universal Kit for Vehicles Which Require a Taillight Converter	C-28
20252	4-Flat Wiring Kit, Contains 72" 16 ga. Car End Connector Universal Kit for Vehicles Which Do Not Require a Taillight Converter	C-28
2026	Shur-Set III® Breakaway System w/5 Amp/Hr Battery (Includes #2010 Nylon Breakaway Switch)	M-5
20260	Brake Control Wiring Adapter, Ford	H-12/15
20260-012	Brake Control Wiring Adapter (12 pack)	H-12/15
20261	Brake Control Wiring Adapter, Dodge	H-12/15
20261-012	Brake Control Wiring Adapter (12 pack)	H-12/15
20263	Brake Control Wiring Adapter, GM	H-12/15
20263-012	Brake Control Wiring Adapter (12 pack)	H-12/15
20264	Brake Control Wiring Adapter, GM	H-12/15
20264-012	Brake Control Wiring Adapter (12 pack)	H-12/15
20265	Brake Control Wiring Adapter, Toyota	H-12/15
20266	Brake Control Wiring Adapter, Nissan	H-12/15
20267	Brake Control Wiring Adapter, Ford	H-12/15
20267-012	Brake Control Wiring Adapter (12 pack)	H-12/15
20268	Brake Control Wiring Adapter, Honda	H-12/15
20269	Brake Control Wiring Adapter, GM	H-12/15
20269-012	Brake Control Wiring Adapter (12 pack)	H-12/15
20270	Brake Control Wiring Adapter, Ford	H-12/15
20271	Brake Control Wiring Adapter, KIA	H-12/15
20272	Brake Control Wiring Adapter, Ford	H-12/15
20272-012	Brake Control Wiring Adapter (12 pack)	H-12/15
20273	Brake Control Wiring Adapter, Dodge	H-12/15
20273-012	Brake Control Wiring Adapter (12 pack)	H-12/15
20274	Brake Control Wiring Adapter, Dodge & Jeep	H-12/15
2028	Shur-Set III® Breakaway System w/5 Amp/Hr Battery (with Charger) (Includes #2010 Nylon Breakaway Switch)	M-5
203111	Side Marker/Clearance Light Amber w/Reflex Lens w/Black Stud-Mount Base	K-43
203113	Side Marker/Clearance Light Red w/Reflex Lens w/Black Stud-Mount Base	K-43
203116	Side Marker/Clearance Light w/Reflex & 18" Pigtail, Red	K-43
203117	Side Marker/Clearance Light w/Reflex & 18" Pigtail, Amber	K-43

NUMERICALS

PART NO.	DESCRIPTION	PAGE #
203131	Side Marker/Clearance Light Amber w/Reflex Lens w/Black Ear-Mount Base	K-43
203133	Side Marker/Clearance Light Red w/Reflex Lens w/Black Ear-Mount Base	K-43
20320	4-Flat to 6-Way Round Pin Connector Adapter	C-50
20320-012	4-Flat to 6-Way Round Pin Connector Adapter (12 pack)	C-50
203206	Mini Launch Light, Waterproof	K-26
20321	4-Flat to 7-Way Flat Pin Connector Adapter, Plastic	C-50
20321-012	4-Flat to 7-Way Flat Pin Connector Adapter, Plastic (12 pack)	C-50
20322	4-Flat to 7-Way Flat Pin Connector Adapter, Metal	C-50
203223	Clearance Light Module #31 Amber, 2-1/2"	K-38
203224	Clearance Light Module #31 Red, 2-1/2"	K-38
203233	Side Marker/Clearance Light Amber w/White Stud-Mount Base, PC Rated	K-39
203234	Side Marker/Clearance Light Red w/White Stud-Mount Base, PC Rated	K-39
203235	Side Marker/Clearance Light Amber, PC Rated	K-44
203263	Side Marker/Clearance Light Amber w/Reflex Lens w/White Base	K-42
203264	Side Marker/Clearance Light Red w/Reflex Lens w/White Base	K-42
203285	Side Marker/Clearance Light Amber w/White Ear-Mount Base, PC Rated	K-39
203286	Side Marker/Clearance Light Red w/White Ear-Mount Base, PC Rated	K-39
203292	Clearance Lens #37 Amber w/Black Base and Wire	K-37
203293	Clearance Lens #37 Red w/Black Base and /Wire	K-37
203294	Clearance Lens #37 Amber w/Chrome Base and Wire	K-37
203295	Clearance Lens #37 Red w/Chrome Base and Wire	K-37
203309	Red, Waterproof, Stainless Steel Bar	K-49
203310	Red, Standard, Black Painted Bar	K-50
203315	Red, Waterproof, Stainless Steel Bar	K-49
203380	Clearance Light Module #30 Amber, 2"	K-38
203381	Clearance Light Module #30 Red, 2"	K-38
203385	Clearance Light Module #31 Amber, 2-1/2"	K-38
203386	Clearance Light Module #31 Red, 2-1/2"	K-38
203395	Clearance Light Module #37 Amber	K-37
203396	Clearance Light Module #37 Red	K-37
20501	Pulse Preventor for use w/All Electronic Brake Controls	H-10
20505	Wiring Kit for 2 to 4 Brake Control Systems, Includes 25 ft. 12-2 Duplex Wire, 20 Amp Circuit Breaker and Attaching Terminals	H-11
20506	Wiring Kit for 6 to 8 Brake Control Systems, Includes 25 ft. 12-2 Duplex Wire, 30 Amp Circuit Breaker and Attaching Terminals	H-11
2051	Replacement Part, Battery Box, All Polymer Lockable	M-6
2060066	Bow Cambuckle Tie Down, 1" x 36", 400 lbs. Load Capacity & 1,200 lbs. Break Strength, Zinc (2 pack)	I-34
2060166	Bow Cambuckle Tie Down, 1" x 36", 300 lbs. Load Capacity & 900 lbs. Break Strength, Stainless Steel (2 pack)	I-34
2060266	Transom Retractable Ratchet Tie Down, 2" x 43", 600 lbs. Load Capacity & 1,800 lbs. Break Strength, Stainless Steel (2 pack)	I-34
2060366	Transom Retractable Ratchet Tie Down, 2" x 43", 833 lbs. Load Capacity & 2,500 lbs. Break Strength, Zinc (2 pack)	I-34
2060466	Transom SureLok Cambuckle Tie Down, 2" x 24", 833 lbs. Load Capacity & 2,500 lbs. Break Strength, Zinc (2 pack)	I-34
2060566	Transom SureLok Cambuckle Tie Down, 2" x 24", 333 lbs. Load Capacity & 1,000 lbs. Break Strength, Stainless Steel (2 pack)	I-34
2060666	Transom SureLok Cambuckle Tie Down, 2" x 48", 333 lbs. Load Capacity & 1,000 lbs. Break Strength, Stainless Steel (2 pack)	I-34
2060766	Transom SureLok Cambuckle Tie Down, 2" x 48", 833 lbs. Load Capacity & 2,500 lbs. Break Strength, Zinc (Single)	I-34
2060866	Gunwale Max Grip Ratchet Tie Down, 2" x 10", 333 lbs. Load Capacity & 1,000 lbs. Break Strength, Stainless Steel (Single)	I-34
2060966	Gunwale Max Grip Ratchet Tie Down, 2" x 13", 400 lbs. Load Capacity & 1,200 lbs. Break Strength, Stainless Steel (Single)	I-34
2061066	Gunwale Max Grip Ratchet Tie Down, 2" x 16", 400 lbs. Load Capacity & 1,200 lbs. Break Strength, Stainless Steel (Single)	I-34
2061166	Gunwale Max Grip Ratchet Tie Down, 2" x 20", 400 lbs. Load Capacity & 1,200 lbs. Break Strength, Stainless Steel (Single)	I-34
2061266	Gunwale Max Grip Ratchet Tie Down, 2" x 10", 833 lbs. Load Capacity & 2,500 lbs. Break Strength, Zinc (Single)	I-34
2061366	Gunwale Max Grip Ratchet Tie Down, 2" x 13", 833 lbs. Load Capacity & 2,500 lbs. Break Strength, Zinc (Single)	I-34

PART NO.	DESCRIPTION	PAGE #
2061466	Gunwale Max Grip Ratchet Tie Down, 2" x 16", 833 lbs. Load Capacity & 2,500 lbs. Break Strength, Zinc (Single)	I-34
2061566	Gunwale Max Grip Ratchet Tie Down, 2" x 20", 833 lbs. Load Capacity & 2,500 lbs. Break Strength, Zinc (Single)	I-34
2061766	Transom Retractable Ratchet Tie Down, 2" x 43", 833 lbs. Load Capacity & 2,500 lbs. Break Strength, Zinc (Bulk)	I-34
2061866	Transom Retractable Ratchet Tie Down, 2" x 43", 600 lbs. Load Capacity & 1,800 lbs. Break Strength, Stainless Steel (Bulk)	I-34
2061966	Transom SureLok Cambuckle Tie Down, 2" x 48", 333 lbs. Load Capacity & 1,000 lbs. Break Strength, Stainless Steel (Bulk)	I-34
21141	Adjustable Ball Mount, 13-1/2"L x 7-1/2"D x 6-1/4"R, 5,000 lbs.	B-11
21330	Forged Ball Mount, 16,000 lbs. GTW, 1-1/4" Ball Hole, 8-1/2" Length, 1" Rise, 2" Drop, Black	B-8
21331	Forged Ball Mount, 16,000 lbs. GTW, 1-1/4" Ball Hole, 9-1/4" Length, 3" Rise, 4" Drop, Black	B-8
21332	Forged Ball Mount, 16,000 lbs. GTW, 1-1/4" Ball Hole, 10-1/4" Length, 5" Rise, 6" Drop, Black	B-8
21341	Quick Loading Ball Mount, 2" Sq. x 12"L x 2"D x 3/4"R, 5,000 lbs.	B-7
21342	Quick Loading Ball Mount, 2" Sq. x 8-1/2"L x 2"D x 3/4"R, 6,000 lbs.	B-7
21342-006	Quick Loading Ball Mount, 2" Sq. x 8-1/2"L x 2"D x 3/4"R, 6,000 lbs. (6 pack)	B-7
21343	Quick Loading Ball Mount, 2" Sq. x 10-1/2"L x 2"D x 3/4"R, 6,000 lbs.	B-7
21343-006	Quick Loading Ball Mount, 2" Sq. x 10-1/2"L x 2"D x 3/4"R, 6,000 lbs. (6 pack)	B-7
21344	Quick Loading Ball Mount, 2" Sq. x 9"L x 4"D x 2-3/4"R, 6,000 lbs.	B-7
21344-006	Quick Loading Ball Mount, 2" Sq. x 9"L x 4"D x 2-3/4"R, 6,000 lbs. (6 pack)	B-7
21345	Quick Loading Ball Mount, 2" Sq. x 11"L x 4"D x 2-3/4"R, 6,000 lbs.	B-7
21345-006	Quick Loading Ball Mount, 2" Sq. x 11"L x 4"D x 2-3/4"R, 6,000 lbs. (6 pack)	B-7
21346	Quick Loading Ball Mount, 2" Sq. x 9-1/2"L x 6"D x 4-3/4"R, 6,000 lbs.	B-7
21346-002	Quick Loading Ball Mount, 2" Sq. x 9-1/2"L x 6"D x 4-3/4"R, 6,000 lbs. (2 pack)	B-7
21347	Ball Mount, 2" Sq. x 10"L x 8"D x 6-3/4"R, 5,000 lbs.	B-7
21348	Ball Mount, 2" Sq. x 9"L x 11"D x 9-3/4"R, 5,000 lbs. (Drop Position) & 3,500 lbs. (Rise Position)	B-7
21381	Aluminum Ball Mount, 8,000 lbs. GTW, 1" Ball Hole, 9-7/8" Length, 1" Rise, 2" Drop	B-8
21382	Aluminum Ball Mount, 8,000 lbs. GTW, 1" Ball Hole, 10-5/8" Length, 3" Rise, 4" Drop	B-8
21383	Aluminum Ball Mount, 8,000 lbs. GTW, 1" Ball Hole, 11-7/8" Length, 5" Rise, 6" Drop	B-8
21384	Aluminum Ball Mount, 6,000 lbs. GTW, 1" Ball Hole, 10-7/8" Length, 7" Rise, 8" Drop	B-8
21501	Replacement Part, Snap-up Bracket w/Set Screw & Safety Pin	D-18
2178	Voyager®, AccuTrac® and Pod® Mounting Kit Bracket	H-10
2180-S	Pulse Preventer	H-10
221088	Grommet - 2-1/2" Round Open Back Heavy Duty	K-31, K-38
2211	Rubber Economy Receiver Tube Cover w/D" Logo for 1-1/4" Sq. Receivers	B-21
221588	Grommet, Rectangular (15 Series)	K-26, K-32, K-34, K-37
22200 0101	Coupler, Ball Size 2", 2" Tongue Mount Width, Straight Channel, Zinc Finish, Rating 3,500 lbs.	J-48
22200 0301	Coupler, Class II, 2" Ball, 2" Channel, 3500 lbs. - Zinc	J-48
22200 0317	Coupler, Class II, 2" Ball, 2" Channel, 3500 lbs. - Primed	J-48
22225	Replacement Part, 800 lbs. High-Performance Spring Bar & Trunnion (Qty. 1)	D-7
22250 0101	Coupler, Ball Size 2", 2-1/2" Tongue Mount Width, Straight Channel, Zinc Finish, Rating 3,500 lbs.	J-48
22250 0301	Coupler, Class II, 2" Ball, 2-1/2" Channel, 3500 lbs. - Zinc	J-48
22250 0317	Coupler, Class II, 2" Ball, 2-1/2" Channel, 3500 lbs. - Primed	J-48
22280	Brake Control Wiring Adapter - 2 plugs, Ford	H-12/15
22281	Brake Control Wiring Adapter - 2 plugs, Dodge	H-12/15
22283	Brake Control Wiring Adapter - 2 plugs, GM	H-12/15
22284	Brake Control Wiring Adapter - 2 plugs, GM	H-12/15

NUMERICALS

PART NO.	DESCRIPTION	PAGE #
22285	Brake Control Wiring Adapter - 2 plugs, Toyota	H-12/15
22286	Brake Control Wiring Adapter - 2 plugs, Nissan	H-12/15
22287	Brake Control Wiring Adapter - 2 plugs, Ford	H-12/15
22288	Brake Control Wiring Adapter - 2 plugs, Honda	H-12/15
22289	Brake Control Wiring Adapter - 2 plugs, GM	H-12/15
22290	Brake Control Wiring Adapter - 2 plugs, Ford	H-12/15
22291	Brake Control Wiring Adapter - 2 plugs, KIA	H-12/15
22292	Brake Control Wiring Adapter - 2 plugs, Ford	H-12/15
22293	Brake Control Wiring Adapter - 2 plugs, Dodge	H-12/15
22294	Brake Control Wiring Adapter - 2 plugs, Dodge & Jeep	H-12/15
22300 0101	Coupler, Ball Size 2", 3" Tongue Mount Width, Straight Channel, Zinc Finish, Rating 3,500 lbs.	J-48
22300 0301	Coupler, Class II, 2" Ball, 3" Channel, 3500 lbs. - Zinc	J-48
22300 0317	Coupler, Class II, 2" Ball, 3" Channel, 3500 lbs. - Primed	J-48
223117	Side Marker/Clearance Light w/Reflex & 18" Pigtail, Amber	K-43
223210	LP Light Assy	K-54
223215	License Plate Light w/Bracket	K-53
2423006	7-Function Submersible Under 80" Taillight, Left/Roadside	K-23
2423008	8-Function Submersible Over 80" Taillight, Left/Roadside	K-24
2423056	6-Function Submersible Under 80" Taillight, Right/Curbside	K-23
2423058	7-Function Submersible Over 80" Taillight, Right/Curbside	K-24
2423273	Pedestal Mount, Amber Marker/Turn - Amber Marker/Turn - Double Sided	K-20
2423274	Pedestal Mount, Red Stop/Tail/Turn - Amber Marker/Turn - Double Sided	K-20
2423275	Pedestal Mount, Red Stop/Tail/Turn - Single Sided - Black Back	K-20
2423283	7-Function Under 80" Combination Taillight #80 Series, Left/Roadside	K-18
2423284	6-Function Under 80" Combination Taillight #80 Series, Right/Curbside	K-18
2423286	Replacement Part, LENS TAILLIGHT REPL 80 SERIES	K-18, K-23/24
2423287	Replacement Part, LENS SIDE REPLACE UNDER 80	K-18, K-23
2423293	8-Function Over 80" Combination Taillight #80 Series, Left/Roadside	K-18
2423294	7-Function Over 80" Combination Taillight #80 Series, Right/Curbside	K-18
2423297	Replacement Part, LENS SIDE REPL OVER 80 LENS	K-18, K-24
2461P01	Winch Handle, 11"	J-62
2471	Replacement Part, Wire Lock Pin 1/2", Used w/Tow Bar Brackets & Cargo Carrier #6502	N-4
2489	Safety Chain, Class III, 30" Length	M-25
2523023	7-Function Submersible Under 80" Taillight, Left/Roadside	K-23
2523024	8-Function Submersible Over 80" Taillight, Left/Roadside	K-24
2523073	6-Function Submersible Under 80" Taillight, Right/Curbside	K-23
2523074	7-Function Submersible Over 80" Taillight, Right/Curbside	K-24
2527511	Submersible Under 80" Taillight Kit w/25' Harness (w/o Clearance/Side Marker Lights) INCAND;TRAILER KIT	K-23
26002	Dual Cam HP Sway Control	D-15
26003	Sway Control Adapter Bracket for use w/Class III/IV 2" Sq. Ball Mounts	D-16
26005	Sway Control Adapter Bracket for use w/Class II 1-1/4" Sq. Drawbars	D-16
26015	Classic Dual Cam HP Sway Control	D-16
26025	Classic Dual Cam HP Sway Control	D-15
26102	Dual Cam HP Sway Control	D-16
26660	Standard Friction Sway Control	D-15
2706	Ball Mount, 5,000 lbs. GTW (Drop Position) & 3,500 GTW (Rise Position), 1" Ball Hole, 9" Length, 9-3/4" Rise, 11" Drop, Black	B-6
271574	7-Function Taillight, Right/Curbside, LED Over 80" 3x8 Low Profile	K-9
271575	8-Function Taillight, Left/Roadside, LED Over 80" 3x8 Low Profile	K-9
271584	7-Function Taillight, Right/Curbside Waterproof	K-10
271584-01	7-Function Taillight, Right/Curbside w/3 Wire Pigtail	K-10
271585	8-Function Taillight, Left/Roadside Waterproof	K-10
271585-01	8-Function Taillight, Left/Roadside w/3 Wire Pigtail	K-10
271594	7-Function Taillight, Right/Curbside, LED Wrap-Around	K-9
271595	8-Function Taillight, Left/Roadside, LED Wrap-Around	K-9

PART NO.	DESCRIPTION	PAGE #
273006	U-80 TAIL LAMP LED LH SUBMERS	K-12
273008	LED Over 80" Submersible Taillight, Left/Roadside	K-12
273056	U-80 TAIL LAMP LED RH SUBMERS	K-12
273058	LED Over 80" Submersible Taillight, Right/Curbside	K-12
273560	LED 6" Oval Courtesy Light, Clear	K-26
273561	LED 6" Oval Stop/Tail/Turn, Red WP	K-11
273564	LED 6" Oval Stop/Tail/Turn, Amber WP	K-11
273565	LIGHT 6" OVAL WHITE LED B/U;W/10 DIODES	K-11
2736	Ball Mount, 5,000 lbs. GTW, 1" Ball Hole, 12" Length, 3/4" Rise, 2" Drop, Black	B-6
2736-006	Ball Mount, 5,000 lbs. GTW, 1" Ball Hole, 12" Length, 3/4" Rise, 2" Drop, Black (6 pack)	B-6
2793	Ball Mount, 5,000 lbs. GTW, 1" Ball Hole, 10" Length, 6-3/4" Rise, 8" Drop, Black	B-6
2793-002	Ball Mount, 5,000 lbs. GTW, 1" Ball Hole, 10" Length, 6-3/4" Rise, 8" Drop, Black (2 pack)	B-6
28023	Pintle Hook Accessories, Lock for 2-1/2" & 3" Lunette Rings	B-16
281594	LAMP-STT LED WRAP ARND RH	K-9
281595	LAMP-STT LED WRAP ARND LH	K-9
2823283	7-Function Under 80" Combination Tail Light #80 Series, Left/Roadside	K-18
2823284	6-Function Under 80" Combination Tail Light #80 Series, Right/Curbside	K-18
2823285	Trailer Light Kit w/25' Wire Harness, w/Rectangular Clearance/Side Marker Lights	K-18
2823293	8-Function Over 80" Combination Taillight #80 Series, Left/Roadside	K-18
2823294	7-Function Over 80" Combination Taillight #80 Series, Right/Curbside	K-18
283006	U-80 TAIL LAMP LED LH SUBMERS	K-12
283056	U-80 TAIL LAMP LED RH SUBMERS	K-12
28351	Hitch Ball, 2" Dia. x 1" Shank, 5000 lbs.	B-5
283561	LED 6" Oval Stop/Tail/Turn, Red	K-11
283564	LED 6" Oval Stop/Tail/Turn, Amber	K-11
283565	LED 6" Oval Backup Light	K-11
28451	Invisi-Hitch Drawbar Kit, Drawbar (2000 lbs. w/3/4" Ball Hole 10-5/8" Length x 3-1/2" Rise), 1/2" Stainless Steel Integral Pin & Clip, Black	B-5
2850	Receiver Fabrication Part, 6" Combo Bar 2" Sq. ID, Unpainted	A-16
2851	Receiver Fabrication Part, 12" Combo Bar 2" Sq. ID, Unpainted	A-16
2852	Receiver Fabrication Part, 24" Combo Bar 2" Sq. ID, Unpainted	A-16
2853	Receiver Fabrication Part, 36" Combo Bar 2" Sq. ID, Unpainted	A-16
2854	Receiver Fabrication Part, 48" Combo Bar 2" Sq. ID, Unpainted	A-16
2858	24" x 30" 2-Sided Aluminum Sign	P-10
2859	Wall/Pole Mount for 24" x 30" Sign	P-10
2860	Curb Stand for 24" x 30" Sign	P-10
287512	Taillight Kit w/25' Wire Harness	K-12
2898	Receiver Fabrication Part, 18" Combo Bar 2" Sq. ID, Unpainted	A-16
2923	Ball Mount Kit, 6,000 lbs. GTW, 1" Ball Hole, 8-1/2" Length, 3/4" Rise, 2" Drop, Black	B-6
29522	Conduit 3/8" - 50' Roll	C-55
29523	Conduit 1/2" - 50' Roll	C-55
2953	Ball Mount Kit, 6,000 lbs. GTW, 1" Ball Hole, 9" Length, 2-3/4" Rise, 4" Drop, Black	B-6
30033	22K Fifth Wheel Hitch Assembly & 90° Fifth Wheel Adapter Harness #50-97-410 (Requires Rails & Installation Kit #30035 or #30095)	E-7
30035	Fifth Wheel Rails and Installation Kit, Includes Brackets and Hardware (10 - Bolt Design)	E-16, E-24/27
30047	16K Fifth Wheel (Rail Kit Sold Separately)	E-9
30047A	Replacement 16K Head w/Support	E-9
30048	20K Fifth Wheel Kwik Slide Slider Unit w/6 Rollers (Requires Rails & Installation Kit #30035 or #30095 and Head Assembly)	E-14
30051	16K Fifth Wheel w/Kwik-Slide (Rail Kit Sold Separately)	E-9
30053	Fifth Wheel Starter Kit	E-15
30054	30K Low Profile Fifth Wheel Hitch	E-7
30055	Fifth Wheel Cover	E-15
30056	Pro Series™ 15K Fifth Wheel Hitch (Includes: Head, Head Support, Handle Kit, Legs & Rail Kit) (4 - Bolt Design)	E-13

NUMERICALS

PART NO.	DESCRIPTION	PAGE #
30056-016	Pro Series™ 15K Fifth Wheel Hitch (Includes: Head, Head Support, Handle Kit, Legs & Rail Kit) (4 - Bolt Design) (16 pack)	E-13
3006	Receiver Fabrication Part, 6" Combo Bar 1-1/4" Sq. ID, Unpainted	A-16
30060	Signature Series Fifth Wheel Rail Kit, GM	E-17/19
30061	Signature Series Fifth Wheel Rail Kit, GM	E-17/19
30062	Signature Series Fifth Wheel Rail Kit, GM	E-17/19
30063	Signature Series Fifth Wheel Rail Kit, GM	E-17/19
30064	Signature Series Fifth Wheel Rail Kit, Ford	E-17/19
30067	Signature Series Fifth Wheel Rail Kit, Dodge	E-17/19
30069	Signature Series Fifth Wheel Rail Kit, Dodge	E-17/19
30070	Elite™ Series 18K Fifth Wheel Slider Unit	E-3
30-07-001	Stop/Tail/Turn Light Surface Mount #07 Series, Right/Curbside	K-17
30-07-002	Stop/Tail/Turn Light Surface/Horizontal Mount #07 Series w/ License Light & Bracket, Left/Roadside	K-17
30-07-003	Stop/Tail/Turn Light Surface Mount #07 Series, Left/Roadside	K-17
30-07-010	Lens for #30-07-001	K-17
30-07-011	Lens for #30-07-002	K-17
30-07-012	Lens for #30-07-003	K-17
30-07-013	Lens for #30-07-100	K-17
30-07-100	Stop/Tail/Turn Light Surface/Horizontal Mount #07 Series w/ License Light & Bracket, Left/Roadside	K-17
30073	Signature Series Fifth Wheel Rail Kit, Ford	E-17/19
30-073813	Interior Utility Light w/Switch, 4" x 2.37"	K-60
30-073833	Clearance Light Red Round w/Two Wire Construction	K-45
30-073834	Clearance Light Amber Round w/Two Wire Construction	K-45
30-073836	Clearance Light Amber Round, Self-Grounding w/Single Black Wire	K-45
30-073837	License Plate Light, Bullet	K-53
30-073840	Tractor Auxiliary Flood Light with Rubber Housing	K-25
30-073843	ID Light Bar Red	K-50
30074	Signature Series Fifth Wheel Rail Kit, Dodge	E-17/19
30075	16K Fifth Wheel Hitch w/ Round Tube Slider (Rail Kit Sold Separately)	E-9
30076	Pro Series™ 15K Fifth Wheel Hitch (Includes: Head, Head Support, Handle Kit, Slider Unit & Rail Kit) (4 - Bolt Design)	E-13
30076-016	Pro Series™ 15K Fifth Wheel Hitch (Includes: Head, Head Support, Handle Kit, Slider Unit & Rail Kit) (4 - Bolt Design) (16 pack)	E-13
30078	Signature Series Fifth Wheel Rail Kit, Toyota	E-17/19
30080	Fifth Wheel Rails and Installation Kit, Includes Brackets and Hardware (10 - Bolt Design)	E-16
30081	Fifth Wheel 20K	E-8
30082	Signature Series Fifth Wheel Rail Kit, GM	E-17/19
30083	Fifth Wheel 20K w/Round Slider Unit	E-8
30084	Fifth Wheel 20K w/Kwik Slide Slider Unit	E-8
30092	Pro Series™ Fifth Wheel Slider Unit w/4 Rollers for 15K, 16K & 20K Head Assemblies (Requires Rails & Installation Kit #30035 or #30095 and Head Assembly)	E-14
30093	Pro Series™ 15K Fifth Wheel Hitch (Includes: Head, Head Support, Handle Kit & Legs) (Rail Kit Sold Separately)	E-13
30093-016	Pro Series™ 15K Fifth Wheel Hitch (Includes: Head, Head Support, Handle Kit & Legs) (Rail Kit Sold Separately) (16 Pack)	E-13
30094	Pro Series™ 15K Fifth Wheel Hitch (Includes: Head, Head Support, Handle Kit & Slider Unit) (Rail Kit Sold Separately)	E-13
30094-016	Pro Series™ 15K Fifth Wheel Hitch (Includes: Head, Head Support, Handle Kit & Slider Unit) (Rail Kit Sold Separately) (16 Pack)	E-13
30095	Fifth Wheel Rails and Installation Kit, Includes Brackets and Hardware (4 - Bolt Design)	E-16, E-24/27
30099	Pro Series™ 15K Fifth Wheel Hitch (Includes: Head, Head Support & Handle Kit) (Legs & Rail Kit Sold Separately)	E-13
30105	6 Pole Square Connector Kit, Male and Female Ends for Tent Trailers	C-35
30-11-001	Mobile Housing Taillight	K-20
30-11-030	Taillight Replacement Lens Mobile Housing/#1600 Red with Reflex	K-20
30118	Pro Series™ 20K Fifth Wheel Hitch (Includes: Head, Head Support & Handle Kit) (Legs & Rail Kit Sold Separately)	E-11

PART NO.	DESCRIPTION	PAGE #
30119	Pro Series™ 20K Fifth Wheel Hitch (Includes: Head, Head Support, Handle Kit & Legs) (Rail Kit Sold Separately)	E-11
30119-016	Pro Series™ 20K Fifth Wheel Hitch (Includes: Head, Head Support, Handle Kit & Legs) (Rail Kit Sold Separately) (16 Pack)	E-11
30120	Pro Series™ 20K Fifth Wheel Hitch (Includes: Head, Head Support, Handle Kit, Legs & Rail Kit) (4 - Bolt Design)	E-11
30120-016	Pro Series™ 20K Fifth Wheel Hitch (Includes: Head, Head Support, Handle Kit, Legs & Rail Kit) (4 - Bolt Design) (16 pack)	E-11
30121	Pro Series™ 20K Fifth Wheel Hitch (Includes: Head, Head Support, Handle Kit & Slider Unit) (Rail Kit Sold Separately)	E-11
30121-016	Pro Series™ 20K Fifth Wheel Hitch (Includes: Head, Head Support, Handle Kit & Slider Unit) (Rail Kit Sold Separately) (16 pack)	E-11
30122	Pro Series™ 20K Fifth Wheel Hitch (Includes: Head, Head Support, Handle Kit, Slider Unit & Rail Kit) (4 - Bolt Design)	E-11
30122-016	Pro Series™ 20K Fifth Wheel Hitch (Includes: Head, Head Support, Handle Kit, Slider Unit & Rail Kit) (4 - Bolt Design) (16 pack)	E-11
30124	Fifth Wheel Mounting Rails Only (4 - Bolt Design)	E-16
30125	Replacement Part, Installation Kit w/Hardware and Brackets for #30095, #30124 (4 - Bolt Design)	E-16
30126	Elite™ Series Rail Kit, Ford	E-4, G-12, G-17/19
30128	Pro Series™ 15K Fifth Wheel Hitch (Includes: Head, Head Support, Handle Kit, Legs & Rail Kit) (10 - Bolt Design)	E-13
30128-016	Pro Series™ 15K Fifth Wheel Hitch (Includes: Head, Head Support, Handle Kit, Legs & Rail Kit) (10 - Bolt Design) (16 pack)	E-13
30129	Pro Series™ 15K Fifth Wheel Hitch (Includes: Head, Head Support, Handle Kit, Slider Unit & Rail Kit) (10 - Bolt Design)	E-13
30129-016	Pro Series™ 15K Fifth Wheel Hitch (Includes: Head, Head Support, Handle Kit, Slider Unit & Rail Kit) (10 - Bolt Design) (16 pack)	E-13
30132	Pro Series™ 20K Fifth Wheel Hitch (Includes: Head, Head Support, Handle Kit, Legs & Rail Kit) (10 - Bolt Design)	E-11
30132-016	Pro Series™ 20K Fifth Wheel Hitch (Includes: Head, Head Support, Handle Kit, Legs & Rail Kit) (10 - Bolt Design) (16 pack)	E-11
30133	Pro Series™ 20K Fifth Wheel Hitch (Includes: Head, Head Support, Handle Kit, Slider Unit & Rail Kit) (10 - Bolt Design)	E-11
30133-016	Pro Series™ 20K Fifth Wheel Hitch (Includes: Head, Head Support, Handle Kit, Slider Unit & Rail Kit) (10 - Bolt Design) (16 pack)	E-11
30134	Replacement Part, Safety Chain Attachment for Elite™ Under-Bed Bolt-On Gooseneck	G-6
30135	Replacement Part, Storage Bag for Elite™ Under-Bed Bolt-On Gooseneck 2-5/16" Pop-In Ball #19311	G-6
30136	Replacement Part, Hole Cover for Elite™ Under-Bed Bolt-On Gooseneck Head Ball Hole	G-6
30137	Elite™ Under-Bed Gooseneck Accessories Kit (Includes: (1) 2-5/16" Pop-In Ball #19311, (1) Storage Bag, (2) Safety Chain Attachments & (1) Hole Cover)	G-6
30138	Elite™ Under-Bed Bolt-On Gooseneck Head with Pop-In™ 2-5/16" Ball, Ford	G-5, G-12
30138-26	Elite™ Under-Bed Gooseneck Complete Hitch, Ford	G-5, G-12
30142	Elite™ Series Fifth Wheel 18K (Pre-Assembled) & 90° Fifth Wheel Adapter Harness #50-97-410	E-3
30143	Elite™ Series Fifth Wheel 25K (Pre-Assembled) & 90° Fifth Wheel Adapter Harness #50-97-410	E-3
30144	Elite™ Series Fifth Wheel 18K w/Slider Unit (Pre-Assembled) & 90° Fifth Wheel Adapter Harness #50-97-410	E-3
30149	Elite™ Series Rail Kit Accessory, Plastic Bedliner Puck Adapter Kit (Includes: (4) Pucks & (4) Spacers)	E-4
3015	Brake Control Wiring Adapter - 2 plugs, GM	H-12/15
3015-P	Brake Control Wiring Adapter - 2 plugs, GM	H-12/15
30-15-001	Taillight #1500 2 Stud Mount - Red Lens	K-19
30-15-015	Taillight #1500 Replacement Lens - Clear	K-19
30-15-101	Taillight #1500 2 Stud Mount with License Light	K-19
30-15-103	Taillight #1500 2 Stud Mount - Clear Lens	K-19
30-15-151	Taillight #1500 2 Stud Mount with License Light & Bracket	K-19
30153	Reese Outboard Fifth Wheel Mounting Rails Only (10 - Bolt Design)	E-6, E-16
30-15-350	Taillight Kit #1500	K-19

NUMERICALS

PART NO.	DESCRIPTION	PAGE #
30156	Rail Kit Mounting Adapter for Attaching 15K, 16K & 20K Standard Fifth Wheel Hitches (For Use with Ford OEM & Elite™ Series Under-Bed Rail Kits)	E-4
30158	Elite™ Series Under-Bed Bolt-On Gooseneck Head with Pop-In™ 2-5/16" Ball, GM & Dodge	G-5, G-12
30158-52	Elite™ Series Under-Bed Gooseneck Complete Hitch, Dodge	G-5, G-12
30158-68	Elite™ Series Under-Bed Gooseneck Complete Hitch, GM	G-5, G-12
30-16-155	License Bracket for #1500 & #1600 Lights	K-53
30-17-011	Taillight Replacement Lens #1500/#1700 Red	K-19
30-17-034	Gasket (Foam) for #178 Clearance Light	K-41
30-173836	Clearance Light Replacement Lens Amber	K-45
30-17-814	Clearance Light #178 Red with White Base, No gasket	K-41
30-17-815	Clearance Light #178 Amber with White Base, No gasket	K-41
3020	Brake Control Wiring Adapter - 2 plugs, Dodge	H-12/15
3020-P	Brake Control Wiring Adapter - 2 plugs, Dodge	H-12/15
3021	Brake Control Wiring Adapter - 2 plugs, Dodge	H-12/15
3021-P	Brake Control Wiring Adapter - 2 plugs, Dodge	H-12/15
3025	Brake Control Wiring Adapter - 2 plugs, GM	H-12/15
3025-P	Brake Control Wiring Adapter - 2 plugs, GM	H-12/15
3026	Brake Control Wiring Adapter - 2 plugs, GM	H-12/15
3026-P	Brake Control Wiring Adapter - 2 plugs, GM	H-12/15
3032	Brake Control Wiring Adapter - 2 plugs, KIA	H-12/15
3032-P	Brake Control Wiring Adapter - 2 plugs, KIA	H-12/15
3034	Brake Control Wiring Adapter - 2 plugs, Ford	H-12/15
3034-P	Brake Control Wiring Adapter - 2 plugs, Ford	H-12/15
3035	Brake Control Wiring Adapter - 2 plugs, Ford	H-12/15
3035-P	Brake Control Wiring Adapter - 2 plugs, Ford	H-12/15
3036	Brake Control Wiring Adapter - 2 plugs, Ford	H-12/15
3036-P	Brake Control Wiring Adapter - 2 plugs, Ford	H-12/15
3040	Brake Control Wiring Adapter - 2 plugs, Toyota	H-12/15
3040-P	Brake Control Wiring Adapter - 2 plugs, Toyota	H-12/15
30-40-001	Clearance Light #400 Red w/Colonial White Base, Oblong 4x2	K-42
30-40-002	Clearance Light #400 Amber w/Colonial White Base, Oblong 4x2	K-42
30-40-011	Clearance Light Replacement Lens #400 Red	K-42
30-40-012	Clearance Light Replacement Lens #400 Amber	K-42
30439	Replacement Part, Installation Kit w/Hardware and Brackets for #30035, #58058 (10 - Bolt Design)	E-16
3045	Brake Control Wiring Adapter - 2 plugs, Dodge & Jeep	H-12/15
3045-P	Brake Control Wiring Adapter - 2 plugs, Dodge & Jeep	H-12/15
30-47-801	Clearance Light #478 Red w/Reflex, w/Colonial White Base	K-42
30-47-802	Clearance Light #478 Amber w/Reflex, w/Colonial White Base	K-42
30-47-803	Clearance Light #478 Red w/Reflex, w/White Base	K-42
30-47-804	Clearance Light #478 Amber w/Reflex, w/White Base	K-42
30-47-811	Clearance Light Replacement Lens #478 Red	K-42
30-47-812	Clearance Light Replacement Lens #478 Amber	K-42
30-48-095	Bulb #1895/#57	K-67
3050	Brake Control Wiring Adapter - 2 plugs, Nissan	H-12/15
3050-P	Brake Control Wiring Adapter - 2 plugs, Nissan	H-12/15
30-50-101	Clearance Light #100 Red Round w/Colonial White Base, 2-3/8"	K-45
30-50-102	Clearance Light #100 Amber Round w/Colonial White Base, 2-3/8"	K-45
30-50-111	Clearance Light Replacement Lens #100 Red	K-45
30-50-112	Clearance Light Replacement Lens #100 Amber	K-45
30-58-001	Clearance Light #58 Red w/White Base	K-40
30-58-002	Clearance Light #58 Amber w/White Base	K-40
30-58-007	Clearance Light #58 Clear w/White Base	K-40
30-58-010	Clearance Light Replacement Lens #58 Red	K-40
30-58-012	Clearance Light Replacement Lens #58 Amber	K-40
30-58-024	Replacement Part, Clearance Light #58 White Base	K-40
30-58-102	Clearance Light Wedge Base Socket Assembly w/o Bulb	K-35, K-40
30-58-702	Clearance Light Wedge Base Socket w/#194 Bulb	K-40/41
30-59-001	Clearance Light #59 Red with Reflex w/White Base	K-40
30-59-002	Clearance Light #59 Amber with Reflex w/White Base	K-40
30-59-003	Clearance Light #59 Red with Reflex w/Black Base	K-40
30-59-004	Clearance Light #59 Amber with Reflex w/Black Base	K-40

PART NO.	DESCRIPTION	PAGE #
30-59-010	Clearance Light Replacement Lens #59 Red	K-40
30-59-012	Clearance Light Replacement Lens #59 Amber	K-40
30-59-054	Gasket (Foam) for #58 & #59 Clearance Light	K-40
30-60-004	LT 5 CARGO DOME W/CHR	K-59
30-60-005	UTIL LT	K-59
30-62-000	License Plate Light, Mini Compact	K-53
30-62-002	License Light #62 w/Black Base & Bracket	K-53
30-62-003	License Light #62 w/ White Base & Bracket	K-53
30-62-030	License Plate Bracket	K-53
30-62-102	License Light #62 w/Black Base (No Bracket)	K-53
30-62-103	License Light #62 w/White Base (No Bracket)	K-53
3065	Brake Control Wiring Adapter - 2 plugs, Ford	H-12/15
3065-P	Brake Control Wiring Adapter - 2 plugs, Ford	H-12/15
30-67-801	678 Series Red Surface Mount Clearance Light w/Reflex Snap on Lens Only	K-41
30-67-802	678 Series Amber Surface Mount Clearance Light w/Reflex Snap on Lens Only	K-41
30-68-047	Gasket (Fiber) for #68 Clearance Light	K-41
30-68-054	Gasket (Foam) for #68 Clearance Light	K-41
30-68-503	Utility/Step Light #68 Clear	K-41
30-68-510	Clearance Light #68 Red with Foam Gasket	K-41
30-68-511	Clearance Light #68 Amber with Foam Gasket	K-41
30-68-729	Clearance Light #68 Red Lens & Base	K-41
30-68-730	Utility/Step Light #68 Clear Lens & Base	K-41
30-68-731	Clearance Light #68 Amber Lens & Base	K-41
3070	Brake Control Wiring Adapter - 2 plugs, Honda	H-12/15
3070-P	Brake Control Wiring Adapter - 2 plugs, Honda	H-12/15
30-72-100	License Plate Bracket, Heavy Duty	K-53
30727	Replacement Part, 15K & 16K Legs (Qty. 2)	E-9
30729	Replacement Part, 20K Head Assembly w/Pivot Beam	E-7
30730	Replacement Part, 20K & 22K Fifth Wheel Base Assembly w/ Adjustment Brackets	E-7
30-76-028	Interior Light Replacement Lens #76	K-59
30-76-123	Interior Light #76 Single with Lens & Switch	K-59
30-76-144	Interior Light #76 Single with Lens, Switch & Cord	K-59
30-76-173	76 Series Single Interior w/Jack	K-59
30-76-223	Interior Light #76 Double with Lens & Switch	K-59
30-76-243	Interior Light #76 Double with Lens & Dual Switch	K-59
30-76-273	76 Series Double Interior w/Jack	K-59
30-78-021	Porch Light Replacement Lens #78 Clear	K-56
30-78-022	Porch Light Replacement Lens #78 Amber	K-56
30-78-515	Porch Light #78 Clear w/Ash White #5 Base	K-56
30-78-516	Porch Light #78 Amber w/Ash White #5 Base	K-56
30-78-517	Porch Light #78 Clear w/Ash White #5 Base & Switch	K-56
30-78-518	Porch Light #78 Amber w/Ash White #5 Base & Switch	K-56
30-78-522	Porch Light #78 Clear w/Black Base	K-56
30-78-523	Porch Light #78 Amber w/Black Base	K-56
30-78-524	Porch Light #78 Clear w/Black Base & Switch	K-56
30-78-525	Porch Light #78 Amber w/Black Base & Switch	K-56
30-78-600	Porch Light #78 Clear w/Chrome Base	K-56
30-79-003	Porch Light #79 Oval Clear w/White #5 Base	K-58
30-79-004	Porch Light #79 Oval Amber w/White #5 Base	K-58
30-79-005	Porch Light #79 Oval Clear w/White #5 Base & Switch	K-58
30-79-006	Porch Light #79 Oval Amber w/White #5 Base & Switch	K-58
30-79-023	Porch Light Replacement Lens #79 Oval Clear	K-58
30-79-024	Porch Light Replacement Lens #79 Oval Amber	K-58
308 0217	Coupler, Ball Size 2" - 2-1/8" Hand-Wheel, Tongue Mount Channel Width 2-7/16", Rating 5,000 lbs.	J-48
308 0317	Coupler, Class III, 2" Ball, 2-7/16" Channel, 5000 lbs.	J-48
30-80-001	Porch Light #80, White Base, Clear Lens (No Switch)	K-57
30-80-002	Porch Light #80, White Base, Amber Lens (No Switch)	K-57
30-80-003	Porch Light #80, White Base, Clear Lens, w/Switch	K-57
30-80-004	Porch Light #80, White Base, Amber Lens, w/Switch	K-57
30-80-005	Porch Light #80, Black Base, Clear Lens (No Switch)	K-57
30-80-007	Porch Light #80, Black Base, Clear Lens, w/Switch	K-57

NUMERICALS

PART NO.	DESCRIPTION	PAGE #
30-80-021	CLR REPL LENS FOR 80 SE	K-57
30-80-022	AMB REPL LENS FOR 80 SE	K-57
30-84-001	Taillight #84 Recessed Double Horizontal Red, Backup - Colonial White Base	K-14
30-84-002	Taillight #84 Recessed Triple Horizontal Red, Red, Backup - Colonial White Base	K-15
30-84-003	Taillight #84 Recessed Triple Horizontal Red, Amber, Backup - Colonial White Base	K-15
30-84-005	Taillight #84 Recessed Triple Horizontal Red, Amber, Backup - Black Base	K-15
30-84-008	Taillight #84 Recessed Double Horizontal Red, Backup - Black Base	K-14
30-84-009	Taillight #84 Recessed Triple Horizontal Red, Red, Backup - Black Base	K-15
30-84-057	Bulb Double Filament for #84, #85, #86 & Mobile Housing Light	K-67
30-84-075	Taillight Screw for #84#, 85, #86 Series & Light Bars	K-4, K-13/15, K-51/52
30-84-101	Taillight #84 Recessed Triple Long Horizontal Red, Backup, Red - Colonial White Base	K-14
30-84-103	Taillight #84 Recessed Triple Long Horizontal Red, Backup, Red - Black Base	K-14
30-84-104	Taillight #84 Recessed Triple Long Horizontal Red, Backup, Amber - Black Base	K-14
30845	Elite™ Series Gooseneck	G-6
30-84-508	Taillight #84 Recessed Double Vertical Red, Backup - Black Base	K-14
30-84-509	Taillight #84 Recessed Triple Vertical Red, Red, Backup - Black Base	K-15
30-84-518	Taillight #84 Recessed Double Red, Amber - Black Base	K-14
30-84-522	Taillight #84 Recessed Triple Horizontal Red, Backup, Red - Black Base	K-15
30-84-523	Taillight #84 Recessed Triple Vertical Red, Red, Backup - White Base	K-15
30-84-527	Taillight #84 Recessed Double Red, Red - Black Base	K-14
30-84-529	Taillight #84 Recessed Double Red, Red w/Red Insert - Black Base	K-14
30-84-530	Taillight #84 Recessed Triple Horizontal Red, Red, Backup - White Base	K-15
30-84-540	Taillight #84 Recessed Double Horizontal Red, Backup - White Base	K-14
30-84-546	Taillight #84 Recessed Double Red, Amber with White Base	K-14
30-84-547	Taillight #84 Recessed Double Red, Red - White Base	K-14
30-84-554	Taillight #84 Recessed Triple Long Vertical Red, Backup, Amber - Black Base	K-14
30850	Sidewinder Wedge Kit, Pro Series™ 15K, 16K & 20K	F-10
30-85-002	Taillight #85 Recessed Triple Horizontal Mount Red, Red, Backup w/Chrome Base	K-15
30-85-003	Taillight #85 Recessed Triple Vertical Mount Red, Amber, Backup Lens w/Chrome Base	K-15
30-85-004	Taillight #85 Recessed Triple Horizontal Mount Red, Amber, Backup w/Chrome Base	K-15
30852	Elite™ Series Rail Kit, Dodge	E-4, G-12, G-17/19
30854	Pro Series™ 16K Fifth Wheel Hitch w/Dual Jaw System (Includes: Head, Head Support & Handle Kit) (Legs & Rail Kit Sold Separately)	E-12
30855	Pro Series™ 16K Fifth Wheel Hitch (Includes: Head, Head Support, Handle Kit & Legs) (Rail Kit Sold Separately)	E-12
30855-016	Pro Series™ 16K Fifth Wheel Hitch (Includes: Head, Head Support, Handle Kit & Legs) (Rail Kit Sold Separately) (16 Pack)	E-12
30856	Pro Series™ 16K Fifth Wheel Hitch (Includes: Head, Head Support, Handle Kit, Legs & Rail Kit) (4 - Bolt Design)	E-12
30856-016	Pro Series™ 16K Fifth Wheel Hitch (Includes: Head, Head Support, Handle Kit, Legs & Rail Kit) (4 - Bolt Design) (16 Pack)	E-12
30857	Pro Series™ 16K Fifth Wheel Hitch (Includes: Head, Head Support, Handle Kit & Slider Unit) (Rail Kit Sold Separately)	E-12
30857-016	Pro Series™ 16K Fifth Wheel Hitch (Includes: Head, Head Support, Handle Kit & Slider Unit) (Rail Kit Sold Separately) (16 Pack)	E-12
30858	Pro Series™ 16K Fifth Wheel Hitch (Includes: Head, Head Support, Handle Kit, Slider Unit & Rail Kit) (4 - Bolt Design)	E-12
30858-016	Pro Series™ 16K Fifth Wheel Hitch (Includes: Head, Head Support, Handle Kit, Slider Unit & Rail Kit) (4 - Bolt Design) (16 Pack)	E-12

PART NO.	DESCRIPTION	PAGE #
30-86-001	Taillight #86 Single Stop, Tail, Turn w/Colonial White Base	K-13
30-86-002	Taillight #86 Single Red Turn w/Colonial White Base	K-13
30-86-004	Taillight #86 Single Amber Turn w/Colonial White Base	K-13
30-86-005	Clearance Light #86 Wrap-Around Red w/Colonial White Base	K-13
30-86-006	Clearance Light #86 Wrap-Around Amber w/Colonial White Base	K-13
30-86-101	Taillight #86 Single Stop, Tail, Turn w/Black Base	K-13
30-86-102	Taillight #86 Single Red Turn w/Black Base	K-13
30-86-103	Taillight #86 Single Vertical Mount Backup w/Black Base	K-13
30-86-104	Taillight #86 Single Amber Turn w/Black Base	K-13
30-86-105	Taillight #86 Single Horizontal Mount Backup w/Black Base	K-13
30-86-202	Clearance Light #86 Wrap-Around Red w/Black Base	K-13
30-86-203	Clearance Light #86 Wrap-Around Amber w/Black Base	K-13
30866	R16 Fifth Wheel (Rail Kit Sold Separately)	E-5
30867	R20 Fifth Wheel (Rail Kit Sold Separately)	E-5
30-86-711	Clearance Light Replacement Lens #86 Wrap-Around Red	K-4, K-13
30-86-712	Clearance Light Replacement Lens #86 Wrap-Around Amber	K-4, K-13
30868	Elite™ Series Rail Kit, GM	E-4, G-12, G-17/19
30869	R16 Fifth Wheel w/ Round Tube Slider #50024 (Rail Kit Sold Separately)	E-5
30870	R20 Fifth Wheel w/ Round Tube Slider #50024 (Rail Kit Sold Separately)	E-5
30-90-016	Bulb #MR16 Halogen	K-67
30-90-021	Bulb #921 for #75 Interior Lights	K-67
30-90-022	Bulb #922 for #79 Porch Lights & Light Bar Center High Mount Stop Lamp	K-67
30-90-041	#1141 BLB	K-67
30-90-156	Bulb #1156 Single Filament for #84, 85, 86, 91, 92 & 1700 Series	K-67
30-90-157	Bulb #1157 Double Filament for #91, 92, 1400, 1500, 1600 & 1700 Series	K-67
30-90-168	Bulb #168 for 60 Series License & Wrap Around Marker Lights	K-67
30-90-194	Bulb #194 for #25, 58, 59, 68 & 178 Series Clearance Lights & Light Bar Identification Lamps	K-67
30-92-001	Taillight Surface Mount #92 Red with White Base	K-16
30-92-002	Taillight Surface Mount #92 Red with Backup with White Base	K-16
30-92-003	Taillight Surface Mount #92 Red with License Bracket with White Base	K-16
30-92-004	Taillight Surface Mount #92 Red with Backup & License Bracket with White Base	K-16
30-92-012	Taillight Replacement Lens for #30-92-001 & 106	K-16
30-92-044	Bezel 15 Degree for #92 Series with White Base	K-16
30-92-064	Bezel 15 Degree for #92 Series with Black Base	K-16
30-92-106	Taillight Surface Mount #92 Red with Black Base	K-16
30-92-107	Taillight Surface Mount #92 Red with Backup with Black Base	K-16
30-92-108	Taillight Surface Mount #92 Red with License Bracket with Black Base	K-16
30-92-109	Taillight Surface Mount #92 Red with Backup & License Bracket with Black Base	K-16
30-92-704	Taillight Replacement Lens Red with Backup for #30-92-002 & 107	K-16
30-92-708	Taillight Replacement Lens Red with License Bracket for #30-92-003 & 108	K-16
30-92-713	Taillight Replacement Lens Red with Backup with License Bracket for #30-92-004 & 109	K-16
30-93-152	76 Series Outlet w/Jack	K-59
30-99-001	Clearance Light #99 Red	K-46
30-99-002	Clearance Light #99 Amber	K-46
30-99-010	Clearance Light Replacement Lens #99 Red	K-46
30-99-012	Clearance Light Replacement Lens #99 Amber	K-46
30-99-040	ID Light Bar Replacement Lens Red	K-51
30-99-042	ID Light Bar Replacement Lens Amber	K-51
30-99-050	ID Light Bar Replacement Lens Red with Spot Light	K-52
30-99-101	Rear- Red Lens w/White Base	K-51
30-99-102	ID Light Bar Front Amber with White Base	K-51
30-99-111	ID Light Bar Rear Red with Spot with White Base	K-52
30-99-114	ID Light Bar CHMSL Only with White Base	K-51
30-99-201	ID Light Bar Rear Red with Black Base	K-51

NUMERICALS

PART NO.	DESCRIPTION	PAGE #
30-99-211	ID Light Bar Rear Red with Spot with Black Base	K-52
30-99-214	ID Light Bar CHMSL Only with Black Base	K-51
30-99-215	ID Light Bar Red	K-49
31-2823285	Taillight Kit w/25' Wire Harness, w/Rectangular Clearance/Side Marker Lights	K-18
3132	Automatic Transmission Cooler Hose, 25 ft.	N-6
31-407540	Trailer Light Kit LED Over 80" 3x8 Low Profile	K-9
31-407560	Trailer Light Kit LED 4x6 Low Profile	K-10
31-59-001	Clearance Light #59 Red with White Base	K-40
31-59-002	Clearance Light #59 Amber with White Base	K-40
31-59-010	Clearance Light Replacement Lens #59 Red	K-40
31-59-012	Clearance Light Replacement Lens #59 Amber	K-40
31-67-808	678 Series Red Surface Mount Clearance Light w/Reflex Lens and 2 Wire White Base	K-41
31-67-809	678 Series Surface Mount Clearance Light w/Reflex Lens and 2 Wire White Base	K-41
3176123	76 INT SGL WH w/SW CL	K-59
31-78-531	Porch Light #78 Clear Lens w/White Base	K-56
31-78-532	Porch Light #78 Amber Lens w/White Base	K-56
31-84-010	Replacement Part, Red Taillight Lens for #84, #85, & #86	K-13/15
31-84-016	Replacement Part, Amber Taillight Lens for #84, #85, & #86	K-13/15
31-84-700	Replacement Part, Vertical Taillight Lens w/Clear Backup for #84, #85, & #86	K-13/15
31-84-711	Replacement Part, Horizontal Taillight Lens w/Clear Backup for #84, #85, & #86	K-13/15
31859	Pro Series™ 16K Fifth Wheel Hitch (Includes: Head, Head Support, Handle Kit, Legs & Rail Kit) (10 - Bolt Design)	E-12
31859-016	Pro Series™ 16K Fifth Wheel Hitch (Includes: Head, Head Support, Handle Kit, Legs & Rail Kit) (10 - Bolt Design) (16 pack)	E-12
31860	Pro Series™ 16K Fifth Wheel Hitch (Includes: Head, Head Support, Handle Kit, Slider Unit & Rail Kit) (10 - Bolt Design)	E-12
31860-016	Pro Series™ 16K Fifth Wheel Hitch (Includes: Head, Head Support, Handle Kit, Slider Unit & Rail Kit) (10 - Bolt Design) (16 pack)	E-12
31-86-101	Taillight #86 Single Stop-Tail-Turn w/Black Base	K-13
31-86-103	Taillight #86 Single Vertical Backup w/Black Base	K-13
31-86-104	Taillight #86 Single Amber Turn w/Black Base	K-13
31-92-001	Taillight Surface Mount #92 Red w/White Base	K-16
31-92-003	Taillight Surface Mount #92 Red with License Bracket w/White Base	K-16
3194-S	Battery Post Adapter	N-7
31-99-001	Clearance Light #99 Red	K-46
31-99-002	Clearance Light #99 Amber	K-46
31-99-215	ID Bar Red Incandescent	K-49
32-003440	Clearance Light Red	K-47
32-003441	Clearance Light Amber	K-47
3201	License Plate Bracket, Plastic, Black	D-12
3202	License Plate Bracket, Plastic, White	D-12
3203	Round Bar Bolt-Together Wt. Dist. Kit, 12,000 lbs. (GTW), 1,200 lbs. (TW)	D-12
3210	Wt. Dist. Shank, 14,000 lbs. (GTW), 1,400 lbs. (TW), 10" Length	D-17
3212	Wt. Dist. Shank, 14,000 lbs. (GTW), 1,400 lbs. (TW), 12" Length	D-17
3214	Wt. Dist. Shank, 14,000 lbs. (GTW), 1,400 lbs. (TW), 14" Length	D-17
3215	Wt. Dist. Shank, 14,000 lbs. (GTW), 1,400 lbs. (TW), 11" Length, Extra Drop and Rise	D-17
323356	Reflector, Red w/Adhesive Back, w/Mounting Holes (4-3/8" x 1-1/4")	K-55
323357	Reflector, Amber w/Adhesive Back, w/Mounting Holes (4-3/8" x 1-1/4")	K-55
3280	Pole Tongue Adapter and Fastener Kit	D-18
3344	Wt. Dist. Shank, 14,000 lbs. (GTW), 1,400 lbs. (TW), 11" Length, Extra Drop (Use in Drop Position Only)	D-17
3400	Standard Friction Sway Control and Adapter, Screw-On Sway Control Assembly	D-16
34-003202	License Plate Bracket, Plastic, White	K-53
34-073813	Interior Utility Light w/Switch	K-60
34-073833	Clearance Light Red Round w/Two Wire Construction & White Base	K-45

PART NO.	DESCRIPTION	PAGE #
34-073834	Clearance Light Amber Round w/Two Wire Construction & White Base	K-45
34-073836	Clearance Light Amber Round, Self-Grounding w/Single Black Wire	K-45
34-073840	Tractor Flood Light with Rubber Housing	K-25
34-073843	ID Light Bar Red	K-50
34-106293	Clearance Light Base, Chrome 2" Snap-Lock Self-Grounding	K-26, K-32, K-37
34-106294	Clearance Light Base, Chrome 2" Snap-Lock Open-Back	K-26, K-32, K-37
34-108119	Mounting Bracket, 6" Oval Tail Light	K-8, K-10/11, K-21, K-26
34-108663	Pigtail - 2 Wire w/ 18" Wire Lead	K-26, K-31/32, K-34, K-37/38, K-54
34-108844	Clearance Light Replacement Lens Red Dual Bulb	K-47
34-11-001	Mobile Housing Taillight	K-20
34141	Safety Chain Loop, Class IV, 10,000 lbs.	A-16
34-15-001	Taillight #1500 2 Stud Mount	K-19
34-15-101	Taillight #1500 2 Stud Mount with License Light	K-19
34-15-151	Taillight #1500 2 Stud Mount with License Light & Bracket	K-19
34-17-011	Lens #1500 Red	K-19
34-17-034	Gasket (Foam) for #178 Clearance Light	K-41
34-17-808	Clearance Light #178 Red with White Base with Foam Gasket	K-41
34-17-809	Clearance Light #178 Amber with White Base with Foam Gasket	K-41
34-223215	License Plate Light with Bracket	K-53
34-271585	8-Function Taillight, Left/Roadside, LED 4x6 Low Profile	K-10
34300 0301	Coupler, Class III, 2" Ball, 3" Channel, 5000 lbs. - Zinc	J-48
34300 0317	Coupler, Class III, 2" Ball, 3" Channel, 5000 lbs. - Primed	J-48
34-40-001	Clearance Light #400 Red Oblong 4x2	K-42
34-40-002	Clearance Light #400 Oblong 4x2 Amber	K-42
34-40-011	Clearance Light Replacement Lens #400 Red	K-42
34-40-012	Clearance Light Replacement Lens #400 Amber	K-42
3442	Sway Control Ball Mounting Bar	D-15/16
34-47-801	Clearance Light #478 with Colonial White Base Red	K-42
34-47-802	Clearance Light #478 with Colonial White Base Amber	K-42
34-47-803	Clearance Light #478 with White Base Red	K-42
34-47-804	Clearance Light #478 with White Base Amber	K-42
34-47-811	Clearance Light Replacement Lens #478 Red	K-42
34-47-812	Clearance Light Replacement Lens #478 Amber	K-42
34-48-095	Bulb #1895 for #99, 100, 378, 400, 478, 1600 & 4782 Series	K-67
34-50-101	Clearance Light #100 Red w/Colonial White Base	K-45
34-50-102	Clearance Light #100 Amber w/Colonial White Base	K-45
34-50-111	Clearance Light Replacement Lens #100 Red	K-45
34-50-112	Clearance Light Replacement Lens #100 Amber	K-45
34-58-001	Clearance Light #58 Red w/ White Base	K-40
34-58-002	Clearance Light #58 Amber w/ White Base	K-40
34-58-010	Clearance Light Replacement Lens #58 Red	K-40
34-58-012	Clearance Light Replacement Lens #58 Amber	K-40
34-58-702	Clearance Light Wedge Base Socket w/#194 Bulb	K-40/41
34-59-001	Clearance Light #59 Red with White Base	K-40
34-59-002	Clearance Light #59 Amber with White Base	K-40
34-59-010	Clearance Light Replacement Lens #59 Red	K-40
34-59-012	Clearance Light Replacement Lens #59 Amber	K-40
34-59-054	Gasket (Foam) for #59 Clearance Light	K-40
34600 0301	Coupler, Class IV, FASLOK, 6000 lbs. - Zinc	J-48
34-62-000	License Plate Light, Mini Compact	K-53
34-62-002	License Light #62 w/Black Base & Bracket	K-53
34-62-003	License Light #62 w/White Base & Bracket	K-53
34-62-030	License Plate Bracket	K-53
34-62-102	License Light #62 w/Black Base (No Bracket)	K-53
34-62-103	License Light #62 w/White Base (No Bracket)	K-53
34-67-801	678 Series Red Surface Mount Clearance Light w/Reflex Snap on Lens Only	K-41
34-67-802	678 Series Amber Surface Mount Clearance Light w/Reflex Snap on Lens Only	K-41

NUMERICALS

PART NO.	DESCRIPTION	PAGE #
34-67-808	678 Series Red Surface Mount Clearance Light w/Reflex Lens and 2 Wire White Base	K-41
34-67-809	678 Series Surface Mount Clearance Light w/Reflex Lens and 2 Wire White Base	K-41
34-68-047	Gasket (Fiber) for #68 Clearance Light	K-41
34-68-054	Gasket (Foam) for #68 Clearance Light	K-41
34-68-503	Utility/Step Light #68 Clear	K-41
34-68-510	Clearance Light #68 Red with Foam Gasket	K-41
34-68-511	Clearance Light #68 Amber with Foam Gasket	K-41
34-72-100	License Plate Bracket, Heavy Duty	K-53
34-76-028	Interior Light #76 Replacement Lens	K-59
34-76-123	Interior Light #76 Single with Lens	K-59
34-76-223	Interior Light #76 Double with Lens	K-59
34-76-243	Interior Light #76 Double with Lens with Dual Switch	K-59
34-78-021	Porch Light #78 Replacement Lens Clear	K-56
34-78-022	Porch Light #78 Replacement Lens Amber	K-56
34-78-515	Porch Light #78 Clear with Ash White #5 Base	K-56
34-78-516	Porch Light #78 Amber with Ash White #5 Base	K-56
34-78-517	Porch Light #78 Clear with Ash White #5 Base & Switch	K-56
34-78-518	Porch Light #78 Amber with Ash White #5 Base & Switch	K-56
34-84-008	Taillight #84 Recessed Double Horizontal Mount Red, Backup with Black Base	K-14
34-84-009	Taillight #84 Recessed Triple Horizontal Mount Red, Red, Backup with Black Base	K-15
34-84-010	Taillight Replacement Lens #84, #85, & #86 Red	K-13/15
34-84-016	Taillight Replacement Lens #84, #85, & #86 Amber	K-13/15
34-84-527	Taillight #84 Recessed Double Red, Red with Black Base	K-14
34-84-529	Taillight #84 Recessed Double Red, Red with Red Insert with Black Base	K-14
34-84-700	Taillight Replacement Lens Horizontal #84, #85, & #86 Clear Backup	K-13/15
34-84-711	Taillight Replacement Lens Vertical #84, #85, & #86 Clear Backup	K-13/15
34-85-750	Taillight #84, #85, #86 Replacement Red w/Red Insert Lens	K-14/15
34-86-101	Taillight #86 Single Stop-Tail-Turn - Black	K-13
34-86-103	Taillight #86 Single Vertical Backup - Black	K-13
34-86-104	Taillight #86 Single Amber Turn - Black	K-13
34-86-202	Clearance Light #86 Wrap-Around Red w/Black Base	K-13
34-86-203	Clearance Light #86 Wrap-Around Amber w/Black Base	K-13
34-86-711	Marker Light #86 Replacement Wrap-Around Lens Red	K-4, K-13
34-86-712	Marker Light #86 Replacement Wrap-Around Lens Amber	K-4, K-13
34-90-021	Bulb #921 for #75 Interior Lights	K-67
34-90-022	Bulb #922 for #79 Porch Lights & Light Bar Center High Mount Stop Lamp	K-67
34-90-041	BULB #1141 QTY (2)	K-67
34-90-168	Bulb #168 for 60 Series License & Wrap Around Marker Lights	K-67
34-90-194	Bulb #194 for #25, 58, 59, 68 & 178 Series Clearance Lights & Light Bar Identification Lamps	K-67
34-92-001	Taillight Surface Mount #92 Red with White Base	K-16
34-92-002	Taillight Surface Mount #92 Red with Backup with White Base	K-16
34-92-003	Taillight Surface Mount #92 Red with License Bracket with White Base	K-16
34-92-004	Taillight Surface Mount #92 Red with Backup & License Bracket with White Base	K-16
34-92-012	Taillight Replacement Lens Red for #30-92-001 & 106	K-16
34-92-704	Taillight Replacement Lens Red with Backup for #30-92-002 & 107	K-16
34-92-708	Taillight Replacement Lens Red with License Bracket for #30-92-003 & 108	K-16
34-92-713	Taillight Replacement Lens Red with Backup with License Bracket for #30-92-004 & 109	K-16
34-93-152	Bunk Light Outlet Polar White with Jack	K-59
34-99-001	Clearance Light #99 Red	K-46
34-99-002	Clearance Light #99 Amber	K-46
34-99-010	Clearance Light Lens #99 Red	K-46
34-99-012	Clearance Light Lens #99 Amber	K-46
3503600	Roof Top Cargo Carrier (49-1/2" x 37" x 7")	I-19

PART NO.	DESCRIPTION	PAGE #
3590	Class I 1-1/4" Drawbar Kit, Drawbar (2000 lbs. w/3/4" Ball Hole 6-5/8" Length x 5/8" Rise), Pin and Clip, Black	B-5
3591	Class I 1-1/4" Drawbar Kit, Drawbar (2000 lbs. w/3/4" Ball Hole 9-3/4" Length x 5/8" Rise), Pin and Clip, Black	B-5
3592	Class I 1-1/4" Drawbar Kit, Drawbar (2000 lbs. w/3/4" Ball Hole 9-3/4" Length x 2-1/8" Rise x 2-3/4" Drop), Pin and Clip, Black	B-5
3593	Class I 1-1/4" Drawbar Kit, Drawbar (2000 lbs. w/3/4" Ball Hole 6-5/8" Length x 2-1/8" Rise x 2-3/4" Drop), Pin and Clip, Black	B-5
3594	Class I 1-1/4" Drawbar Kit, Drawbar (2000 lbs. w/3/4" Ball Hole 10" Length x 4" Rise), Pin and Clip, Black	B-5
35SM28FZ	2500 lbs., Square Tube, Fixed Mount	J-35
36010	Premium Receiver - Multi-Fit Motorhome	A-14
36051	Class II Drawbar Kit, Drawbar (3500 lbs. w/3/4" Ball Hole 7" Length x 5/8" Rise x 1-1/4" Drop), Pin and Clip, Black	B-5
36053	Class II Drawbar Kit, Drawbar (3500 lbs. w/3/4" Ball Hole 9-3/4" Length x 5/8" Rise x 1-1/4" Drop), Pin and Clip, Black	B-5
36061	Class II Drawbar Kit, Drawbar (3500 lbs. w/3/4" Ball Hole 9-3/4" Length x 3-1/8" Rise), Pin and Clip, Black	B-5
36063	Class II Drawbar Kit, Drawbar (3500 lbs. w/3/4" Ball Hole 11-3/4" Length x 3-1/8" Rise), Pin and Clip, Black	B-5
36065	Class II Drawbar Kit, Drawbar (3500 lbs. w/3/4" Ball Hole 10" Length x 5" Rise), Pin and Clip, Black	B-5
36071	Class II Drawbar Kit, Drawbar (3500 lbs. w/3/4" Ball Hole 7-3/16" Length x 2-5/8" Rise x 3-1/4" Drop), Pin and Clip, Black	B-5
36078	Class II Drawbar Kit, Drawbar (3500 lbs. w/3/4" Ball Hole 7-3/8" Length x 4-3/4" Drop), Pin and Clip, Black	B-5
37-0030	5 Hitch & 4 Ball Mount Display Stand (Hitches Sold Separately)	P-2
37-0209	Fifth Wheel Display	P-3
37034	Multi-Fit Receiver - Round Tube	A-10
37051	Multi-Fit Receiver - Round Tube	A-10
37069	Multi-Fit Receiver - Round Tube	A-10
37152	Multi-Fit Receiver	A-10
37-2046	Display Stand for Bike Racks	P-5
37-2048	Bargman® Mini Light Display	P-5
37-2049	Wesbar® Mini Light Display	P-5
37-2051	24" x 30" 2-Sided Aluminum Sign	P-10
37-2078	Replacement Part, (10) 6" Peg Hooks	P-7
37-2081	Replacement Part, (50) 8" Peg Hooks	P-7
37-2082	4" Peg Board Hooks (50 pack)	P-7
37-2103	Fifth Wheel & Gooseneck Display	P-3
37-2109	Weight Distributing Display Stand	P-2
37-2110	Brake Control Table Top Display, Holds 2-Units	P-5
37-2112	Ball Mount Display for Lozier Gondola Shelf - Holds Qty. 34	P-7
37-2114	Hitch Ball Display for Lozier Gondola Shelf - Holds Qty. 45-60	P-7
37-2115	Brake Control Display for Activator® III #5520	P-5
37-2116	Brake Control Display for Brakeman™ Ultra #83520	P-5
37-2118	Gooseneck Display	P-4
37-2122	Gooseneck Display	P-4
37-2123	Fifth Wheel Heads Display Stand	P-3
37-2124	Toylok Countertop Display	P-5
37-2125	DISPLAY MARINE JACK	P-4
37-2126	DISPLAY RV JACK	P-4
37-2127	Ball Mount & Hitch Ball Display for Lozier Gondola Shelf	P-7
37-2128	7' x 4' Gondola	P-7
37-2129	Pro Series™ Fifth Wheel Display	P-3
37-2130	Pin Box Display	P-3
37-2131	Trailer Jack A-Frame Cross Bar for Lozier Gondola	P-7
37-2132	Trailer Jack A-Frame Mounting Bracket for Lozier Gondola	P-7
37-2133	Trailer Jack A-Frame Mounting Support Bracket for Lozier Gondola	P-7
37-2134	Trailer Jack A-Frame Display Components for Lozier Gondola (Includes (1) 37-2131, (5) 37-2132 & (1) 37-2133)	P-7
37-5365	4 Ft. Lozier Gondola	P-7
37-5366	4 Ft. Lozier Island Gondola	P-7
37-5367	2 Ft. Lozier Gondola	P-7
37-5637	2 Hitch Display Stand w/Pegboard (Hitches Sold Separately)	P-2
37-5638	4 Hitch Display Stand (Hitches Sold Separately)	P-2
37-5652	24" x 30" 2-Sided Aluminum Sign	P-10

NUMERICALS

PART NO.	DESCRIPTION	PAGE #
37-6297	Display Stand for Cargo Carriers and Bike Racks	P-5
37-6475	ROLA® Roof Rack Display, use #59504 with #37-6297	P-5
37-6666	4 Ft. Lozier Gondola Shelf for #37-5365, #37-5366	P-7
38023	Super Titan® 3000 20K Weld-On Receiver w/3" Sq. Ball Mount & 2-5/16" Ball, Includes 3/4" Pin & Clip	A-12
3808	Economy Circuit Tester	O-2
38124	Super Titan® 4000 25K Weld-On Receiver w/3" Sq. Ball Mount & 2-5/16" Ball, Includes 3/4" Pin & Clip	A-12
38173	ROLA®, Adventure System for RV Accessory Hitch Using 3/8" Pin Hole (Includes Tray w/Lights, Pod & 1-1/4" Assy.)	I-17
38180	Super Titan®, Dual Ball Mount, 25,000 lbs. GTW/4000 lbs. TW, 2-5/16" Ball (25,000 lbs.) & 2" Ball (17,000 lbs.), 9" Length, Black	A-12, B-12
38186	Super Titan®, 3" Receiver Pintle Hook Mounting Plate, 9" Shank, 9" x 5" Plate Size, 25,000/4,000 lbs.	A-12, B-15
38208	Super Titan® 4000 25K Bolt-On Receiver w/3" Sq. Dual Ball Mount, 2" & 2-5/16" Balls, Includes 3/4" Pin & Clip	A-12
38210	6 Trailer Wire, 14 ga., 100' Spool	C-55
38211	Super Titan® 3000 20K Weld-On Receiver w/3" Sq. Ball Mount & 2-5/16" Ball, Includes 3/4" Pin & Clip	A-12
38250	Primary Wire, 12 Gauge x 2, Black & Blue, 500' Spool	C-55
38262	Primary Wire, 12 Gauge, White, 500' Spool	C-55
38263	Primary Wire, 12 Gauge, Black, 500' Spool	C-55
38264	Primary Wire, 12 Gauge, Blue, 500' Spool	C-55
38265	Primary Wire, 14 Gauge, White, 500' Spool	C-55
38266	Primary Wire, 14 Gauge, Blue, 500' Spool	C-55
38267	Primary Wire, 14 Gauge, Red, 500' Spool	C-55
38268	Primary Wire, 14 Gauge, Black, 500' Spool	C-55
38269	Primary Wire, 16 Gauge, Green, 500' Spool	C-55
38270	Primary Wire, 16 Gauge, Yellow, 500' Spool	C-55
38271	Primary Wire, 16 Gauge, White, 500' Spool	C-55
38272	Primary Wire, 16 Gauge, Brown, 500' Spool	C-55
38279	Primary Wire, 10 Gauge, Black, 500' Spool	C-55
38330-100	Butt Connectors, 14-16 Gauge Wire, Blue (100 pack)	C-56
38331-100	Insulated Ring Terminal, 14-16 Gauge Wire, 3/16" Stud Size (100 pack)	C-56
38332-100	Butt Connectors, 10-12 Gauge Wire, Yellow (100 pack)	C-56
38335-100	Insulated Ring Terminal, 5/16" Stud Size (100 pack)	C-56
38337-100	Insulated Ring Terminal, 10-12 Gauge Wire, 3/16" Stud Size (100 pack)	C-56
38338-100	Insulated Ring Terminal, 10-12 Gauge Wire, 1/4" Stud Size (100 pack)	C-56
38339-100	Insulated Ring Terminal, 10-12 Gauge Wire, 3/8" Stud Size (100 pack)	C-56
38341-100	Fully Insulated Disconnect Female Connector, 1/4" 16 Gauge Wire (100 pack)	C-56
38342-100	Scotch Locks, 10-12 Gauge, Yellow (100 pack)	C-56
38371	Replacement Part, T-Handle T-27 Torx Driver (Qty.2) Service Kit for Roof Racks	I-6
38373-*	Replacement Part, Service Kit Keys (Qty.4) for Roof Rack Locks	I-6
38374-*	Roof Rack Accessory, Locks & Keys (Qty.4) for Roof Rack Locks	I-6
38400-100	Scotch Locks, 14-16 Gauge, White (100 pack)	C-56
38410-100	Scotch Locks, 16-18 Gauge, Blue (100 pack)	C-56
38422	Replacement Part, Mounting Pads (Qty.4) Service Kit for #38291 & #59842	I-6
38423	Replacement Part, Mounting Pads (Qty.4) Service Kit for #38316 & #59870	I-6
38424	Replacement Part, Mounting Pads (Qty.4) Service Kit for #38736 & #59866	I-6
38425	Replacement Part, Mounting Pads (Qty.4) Service Kit for #38254 & #59800	I-6
38426	Replacement Part, Mounting Pads (Qty.4) Service Kit for #38441	I-6
38427	Replacement Part, Self-Adhesive Rubber Mounting Pads (Qty.4) Service Kit for RB Series	I-6
38428	Replacement Part, Self-Adhesive Rubber Mounting Pads (Qty.4) Service Kit for RBXL Series	I-6
38429	Replacement Part, Self-Adhesive Rubber Mounting Pads (Qty.4) Service Kit for GTX Series	I-6
38550-100	14-1/2" Cable Ties, (100 pack)	C-56
38551-100	8" Cable Ties, (100 pack)	C-56

PART NO.	DESCRIPTION	PAGE #
38620	In-Line 20 Amp Circuit Breaker w/Mounting Bracket	C-57
38620-010	In-Line 20 Amp Circuit Breaker w/Mounting Bracket (10 pack)	C-57
38630	In-Line 30 Amp Circuit Breaker w/Mounting Bracket	C-57
38630-010	In-Line 30 Amp Circuit Breaker w/Mounting Bracket (10 pack)	C-57
38640	In-Line 40 Amp Circuit Breaker w/Mounting Bracket	C-57
38640-010	In-Line 40 Amp Circuit Breaker w/Mounting Bracket (10 pack)	C-57
38650	In-Line Fuse Holder w/20 Amp Fuse	C-55
38654	40 Amp Large Maxi Automotive Fuse	C-55
38659-010	SPDT 5 Terminal Micro Relay, 12 Volt, 30 Amp, 1997-Up Ford F-150/F-250 (10 pack)	C-55
38660-010	SPDT 5 Terminal Relay, 14 Volt, 20 Amp, 1999-Up Ford F-250/F-350 (10 pack)	C-55
38661-010	Fuse Line, 32 Volt, 30 Amp, 98-Up Dodge	C-55
38665-012	4 Terminal Relay, 12 Volt, 2007-Up Chevrolet Equinox, Pontiac Torrent & Suzuki XL-7/2008-Up Ford Escape, Mazda Tribute & Mercury Mariner (12-pack)	C-55
38735	Super Titan® Receiver Adapter, Reduces Receiver Tube From 3" to 2"	A-12, B-13
39552	Heavy-Duty Flasher	C-55
39552-012	Heavy-Duty Flasher (12 pack)	C-55
40-00-002	Pigtail - 2 Wire w/6" Wire Lead	K-26, K-31/32, K-34, K-37/38, K-54
40-00-003	Pigtail - 3 Wire Sealed	K-8, K-10/11, K-21, K-26
40-00-004	Pigtail - 3 Wire 90°	K-8/11, K-21, K-26
40-00-005	#58 Series LED Pigtail - 2 Wire	K-35
40-00-006	Pigtail - 3 Wire, LED Round 4"	K-9
40-01-001	Sealed 4" Round Red Stop, Tail, Turn	K-21
40-01-003	Sealed 4" Round Clear Backup Light	K-21
40-01-020	Grommet - Sealed 4" Round Taillight	K-9, K-21
40-06-001	Sealed 6" Oblong Red Tail Light	K-21
40-06-002	Sealed 6" Oblong Amber Turn Light	K-21
40-06-003	Sealed 6" Oblong Backup Light	K-21
40-06-020	Grommet - Sealed 6" Oblong Taillight	K-8, K-10/11, K-21, K-26
40108	Replacement Pilot Bits for Rotabroach Cutting Tools	O-3
40109	Rotabroach Hole Cutting Tool, 3/8" Diameter	O-3
40110	Rotabroach Hole Cutting Tool, 7/16" Diameter	O-3
40119	16K Fifth Wheel w/Round Slider Unit #50008 (Requires Rails & Installation Kit #30035)	E-10
40-15-001	Surface Mount Compact Red Stop, Tail, Turn	K-20
40-15-003	Surface Mount Compact Amber Turn, Running Light	K-20
40-15-005	Interior Dome Light with Switch	K-60
401563	LED 6" Oval Taillight, Vertical Mount (Grommet & Connector Sold Separately)	K-10
401565	Clearance Light LED #99 Amber	K-32
401566	Clearance Light LED #99 Red	K-32
401567	Light Bar LED w/Red Lens	K-48
401576	LED 2" Round Amber Marker/Clearance Light (Grommet & Plug Sold Separately)	K-31
401577	LED 2" Round Red Marker/Clearance Light (Grommet & Plug Sold Separately)	K-31
401578	Clearance Light Module LED #31 Amber	K-31
401579	Clearance Light Module LED #31 Red	K-31
401580	LED 2" Amber Marker/Clearance Light, Base & Connector	K-32
401581	LED 2" Red Marker/Clearance Light, Base & Connector	K-32
401582	Clearance Light Module LED #38 Amber	K-36
401583	Clearance Light Module LED #38 Red	K-36
401584	LED 6" Oval Taillight, Horizontal Mount (Grommet & Plug Sold Separately)	K-10
401585	Clearance Light LED #58 Amber	K-35
401586	Clearance Light LED #58 Red	K-35
401589	2" Round Grommet & 2 Wire Connector	K-31, K-38
401591	6" Oval Grommet & 3 Wire Connector	K-8, K-10/11, K-21, K-26

NUMERICALS

PART NO.	DESCRIPTION	PAGE #
40200	Hollow Shank Ball Mount, 10,000 lbs. GTW, 1-1/4" Ball Hole, 8-1/2" Length, 3/4" Rise, 2" Drop, Black	B-9
40201	Hollow Shank Ball Mount, 10,000 lbs. GTW, 1-1/4" Ball Hole, 9" Length, 2-3/4" Rise, 4" Drop, Black	B-9
40202	Hollow Shank Ball Mount, 10,000 lbs. GTW, 1-1/4" Ball Hole, 11-1/4" Length, 2-3/4" Rise, 4" Drop, Black	B-9
40205	Hollow Shank Ball Mount, 10,000 lbs. GTW, 1-1/4" Ball Hole, 9" Length, 6" Drop, Black	B-9
40206	Hollow Shank Ball Mount, 10,000 lbs. GTW, 1-1/4" Ball Hole, 9" Length, 8" Drop, Black	B-9
40-30-001	Clearance Light Sealed Module, #30 Red	K-38
40-30-002	Clearance Light Sealed Module, #30 Amber	K-38
40-30-020	Grommet - 2" Round Clearance Light	K-31, K-38
403025	Over 80" Submersible Taillight, Left/Roadside (Black)	K-24
403026	Taillight, Waterproof Low-Profile Over 80" - Left/Roadside	K-22
403075	Over 80" Submersible Taillight, Right/Curbside (Black)	K-24
403076	Taillight, Waterproof Low-Profile Over 80" - Right/Curbside	K-22
403080	Taillight, Sealed Oval Set (Module, Grommet & Harness)	K-21
403085	Taillight Module for #003080	K-21
403087	Clear Lamp Module for #003080 (Courtesy Light)	K-21
40-31-001	Clearance Light Sealed Module, #31 Red	K-38
40-31-002	Clearance Light Sealed Module, #31 Amber	K-38
40-31-020	Grommet - 2-1/2" Round Clearance Light	K-31, K-38
40330	Forged Ball Mount, 16,000 lbs. GTW, 1-1/4" Ball Hole, 8-1/2" Length, 1" Rise, 2" Drop, Black	B-8
40330-002	Forged Ball Mount, 16,000 lbs. GTW, 1-1/4" Ball Hole, 8-1/2" Length, 1" Rise, 2" Drop, Black (2 pack)	B-8
40331	Forged Ball Mount, 16,000 lbs. GTW, 1-1/4" Ball Hole, 9-1/4" Length, 3" Rise, 4" Drop, Black	B-8
40331-002	Forged Ball Mount, 16,000 lbs. GTW, 1-1/4" Ball Hole, 9-1/4" Length, 3" Rise, 4" Drop, Black (2 pack)	B-8
40332	Forged Ball Mount, 16,000 lbs. GTW, 1-1/4" Ball Hole, 10-1/4" Length, 5" Rise, 6" Drop, Black	B-8
40332-002	Forged Ball Mount, 16,000 lbs. GTW, 1-1/4" Ball Hole, 10-1/4" Length, 5" Rise, 6" Drop, Black (2 pack)	B-8
403336	Waterproof Low-Profile Over 80" Taillight and Clearance Light Replacement Lens Set w/Screw	K-22
403348	Replacement Part, Sonically Sealed Waterproof Bulb Capsule for Part #007509	K-22
40342	Quick-Loading Ball Mount, 6,000 lbs. GTW, 1" Ball Hole, 8-1/2" Length, 3/4" Rise, 2" Drop, Black	B-6
40342-006	Quick-Loading Ball Mount, 6,000 lbs. GTW, 1" Ball Hole, 8-1/2" Length, 3/4" Rise, 2" Drop, Black (6 pack)	B-6
40343	Quick-Loading Ball Mount, 6,000 lbs. GTW, 1" Ball Hole, 10-1/2" Length, 3/4" Rise, 2" Drop, Black	B-6
40343-006	Quick-Loading Ball Mount, 6,000 lbs. GTW, 1" Ball Hole, 10-1/2" Length, 3/4" Rise, 2" Drop, Black (6 pack)	B-6
40344	Quick-Loading Ball Mount, 6,000 lbs. GTW, 1" Ball Hole, 9" Length, 2-3/4" Rise, 4" Drop, Black	B-6
40344-006	Quick-Loading Ball Mount, 6,000 lbs. GTW, 1" Ball Hole, 9" Length, 2-3/4" Rise, 4" Drop, Black (6 pack)	B-6
40345	Quick-Loading Ball Mount, 6,000 lbs. GTW, 1" Ball Hole, 11" Length, 2-3/4" Rise, 4" Drop, Black	B-6
40345-006	Quick-Loading Ball Mount, 6,000 lbs. GTW, 1" Ball Hole, 11" Length, 2-3/4" Rise, 4" Drop, Black (6 pack)	B-6
40346	Quick-Loading Ball Mount, 6,000 lbs. GTW, 1" Ball Hole, 9-1/2" Length, 4-3/4" Rise, 6" Drop, Black	B-6
40346-002	Quick-Loading Ball Mount, 6,000 lbs. GTW, 1" Ball Hole, 9-1/2" Length, 4-3/4" Rise, 6" Drop, Black (2 pack)	B-6
40-37-001	Clearance Light Sealed Module, #37 Red	K-37
40-37-002	Clearance Light Sealed Module, #37 Amber	K-37
40-37-020	Clearance Light Base, Black 2" Snap-Lock, Open Back	K-26, K-32, K-37
40-37-401	Clearance Light Sealed Module, #37 Red	K-37
40-37-402	Clearance Light Sealed Module, #37 Amber	K-37
40376	Test Light	O-2
40-38-001	Clearance Light Sealed Module, #38 Red	K-37
40-38-002	Clearance Light Sealed Module, #38 Amber	K-37
40-38-004	Clearance/Side Light Red/Amber (No Base)	K-37
40-38-020	Clearance Light Base 3-13/16" x 1-1/4", Black with Wire Assembly	K-36/37

PART NO.	DESCRIPTION	PAGE #
40-38-025	DBL CL LT BK BASE & 2WR	K-36/37
40381	Aluminum Ball Mount, 8,000 lbs. GTW, 1" Ball Hole, 9-7/8" Length, 1" Rise, 2" Drop	B-8
40382	Aluminum Ball Mount, 8,000 lbs. GTW, 1" Ball Hole, 10-5/8" Length, 3" Rise, 4" Drop	B-8
40383	Aluminum Ball Mount, 8,000 lbs. GTW, 1" Ball Hole, 11-7/8" Length, 5" Rise, 6" Drop	B-8
40384	Aluminum Ball Mount, 6,000 lbs. GTW, 1" Ball Hole, 10-7/8" Length, 7" Rise, 8" Drop	B-8
40-39-001	Mini-Clearance/Marker Light Red	K-45
40-40-004	Fender Mount Clearance Light #40 Red/Amber with Lexan Black Base and Screws	K-46
40-40-006	Fender Mount Clearance Light #40 Red/Amber with Black Base	K-46
40-40-104	Fender Mount Clearance Light #40 Red/Amber	K-46
40-40-115	Fender Mount Clearance Light Bezel Only Base with Lens Adhesive	K-46
40-40-120	Two Light Fender Mount Bezel Only (Red/Amber #38 or #99 Series)	K-37, K-46
40-41-001	Clearance/Marker Light Red Rectangular Chrome Base	K-44
40443	Packaged Ball Mount, 6,000 lbs. GTW, 1" Ball Hole, 10-1/2" Length, 3/4" Rise, 2" Drop, Black	B-6
40446	Packaged Ball Mount, 6,000 lbs. GTW, 1" Ball Hole, 9-1/2" Length, 4-3/4" Rise, 6" Drop, Black	B-6
40563-002	Towing Starter Kit, w/Quick-Loading 2" Sq. Ball Mount, 6,000 lbs. GTW, 1" Ball Hole, 8-1/2" Length, 3/4" Rise, 2" Drop & 2" Chrome Hitch Ball w/Pin & Clip (2 Pack)	B-10
40565	Towing Starter Kit, w/Interlock™ (Hex) Feature Ball Mount 2" Sq. x 8-1/2"L x 2"D x 3/4"R, 6000 lbs. & 2" Hitch Ball w/Lock, Plastic Storage Case	B-10
40566-002	Towing Starter Kit, w/Quick-Loading 2" Sq. Ball Mount, 6,000 lbs. GTW, 1" Ball Hole, 9" Length, 2-3/4" Rise, 4" Drop & 2" Chrome Hitch Ball w/Pin & Clip	B-10
40567-002	Towing Starter Kit, w/Quick-Loading 2" Sq. Chrome Ball Mount, 6,000 lbs. GTW, 1" Ball Hole, 8-1/2" Length, 3/4" Rise, 2" Drop & 2" Chrome Hitch Ball w/Pin & Clip (2 Pack)	B-10
40-60-001	Security/Utility Light 7" with Chrome Base	K-57
40-60-004	Security/Utility Light 7" with White Base	K-57
40602	Heavy-Duty Bracket Kit for DT #2480, HH #40601, RS #74950, TR #63180 Tow Bar, Rating 5,000 lbs., Zinc	N-4
40604	Heavy-Duty Safety Chain Kit for DT #2480, HH #40601, RS #74950, TR #63180 Tow Bar, 30" w/Quick Links, Rating 5,000 lbs. (Qty. 4)	N-4
407500	Standard Under 80" Trailer Light Kit w/20' Wire Harness (No Clearance/Side Marker Lights)	K-18
407515	Submersible Over 80" Taillight Kit w/Side Marker/Clearance Lights	K-24
407530	LED Low Profile Waterproof 7-Function Taillight, Right/Curbside	K-9
407535	LED Low Profile Waterproof 8-Function Taillight, Left/Roadside	K-9
407540	LED Low Profile Waterproof Trailer Light Kit	K-9
407550	7-Function Taillight, Right/Curbside	K-10
407555	8-Function Taillight, Left/Roadside	K-10
407560	Taillight Kit LED 4x6 Low Profile	K-10
40-767758	6" Amber Oval LED Surface Mount Light w/Black Flange Base	K-11
41010	Transmission Oil Cooler kit 3/4"H x 5"W x 12-3/4"L, Light Duty Tube & Fin	N-5
41011	Transmission Oil Cooler kit 3/4"H x 7-1/2" W x 12-3/4"L, Medium Duty Tube & Fin	N-5
41013	Transmission Oil Cooler kit 3/4"H x 7-1/2" W x 15-1/2"L, Heavy Duty Tube & Fin	N-5
41014	Transmission Oil Cooler kit 3/4"H x 10" W x 15-1/2"L, Extra Heavy Duty Tube & Fin	N-5
41019	Transmission Oil Cooler kit, Hi-Performance, 3/4"H x 4"W x 11"L, Light Duty Plate & Fin	N-5
41020	Transmission Oil Cooler kit, Hi-Performance, 3/4"H x 5-3/4"W x 11"L, Medium Duty Plate & Fin	N-5
41102	Transmission Oil Cooler Hose, 11/32" x 4-1/2"	N-6
41103	Transmission Oil Cooler Metal Strap Mounting Kit	N-6
41-30-001	Clearance Light Sealed Module, #30 Red	K-38
41-30-002	Clearance Light Sealed Module, #30 Amber	K-38
41310	Transmission Cooler, Hi-Performance, 3/4"H x 7-1/4"W x 11"L, Heavy Duty Plate & Fin	N-5
41-31-001	Clearance Light Sealed Module, #31 Red	K-38

NUMERICALS

PART NO.	DESCRIPTION	PAGE #
41-31-002	Clearance Light Sealed Module, #31 Amber	K-38
41311	Transmission Cooler, Hi-Performance, 3/4"H x 12"W x 11"L, Extra Heavy Duty Plate & Fin	N-5
41312	Transmission Cooler, Hi-Performance, 1-1/2"H x 11"W x 11"L, Premium Heavy Duty Plate & Fin	N-5
413560	Taillight Assy, Oval Grommet, Red	K-21
41-37-031	Clearance Light Sealed #37 Red with Black Base and Wire	K-37
41-37-032	Clearance Light Sealed #37 Amber with Black Base and Wire	K-37
41-38-031	Clearance Light Sealed #38 Red with Black Base and Wire Assembly	K-37
41-38-032	Clearance Light Sealed #38 Amber with Black Base and Wire Assembly	K-37
41405	Transmission Oil Cooler Nylon Tie Mounting Kit	N-6
41410	Transmission Cooler Line Fitting Kit, for use on 1983 or Later Ford, Lincoln & Mercury Cars, 1/4" MPT	N-6
41411	Transmission Cooler Line Fitting Kit, for 1987 & Earlier Jeep, 1991 to Current GM Fwd, 1996 & Later GM Full Size Truck & Van, 5/8"-18	N-6
41412	Transmission Cooler Line Fitting Kit, for 1987 & Later Jeep, 5/8" SAE (45° Flare)	N-6
41413	Transmission Cooler Line Fitting Kit, for 1987 & Later Jeep, 1995 & Later Dodge Full Size Truck & Van, 3/8" x 3/8" (Quick Disconnect Fitting)	N-6
41414	Transmission Cooler Line Fitting Kit, 1985-1995 Chevrolet Astro & GMC Safari Vans, 1/2" x 20 Inv. Flare	N-6
41415	Transmission Cooler Line Fitting Kit, 1983 & Later Ford, Lincoln & Mercury Cars & Full Size Trucks & Vans 1/2" x 20 Inv. Flare	N-6
41416	Transmission Cooler Line Fitting Kit, 1999 & Later Dodge Full Size Trucks 9/16"-18 JIC (37° Flare)	N-6
41417	Transmission Cooler Line Fitting Kit, 1987 & Later Ford Aerostar, Explorer, Expedition, F-Series Trucks & Ranger, 11/32" HB x 1/4" MPT (1) & 11/32" HB x 3/8" MPT (1)	N-6
41418	Transmission Cooler Line Fitting Kit, 1996 & Later GM, Snap-In Fitting	N-6
416088	Taillight Oval Grommet	K-8, K-10/11, K-21, K-26
417515	Light & Wire Kit, Submersible Over 80" w/20' Harness	K-24
4197S00	Service Kit-Ratchet Repair -T2000, T2500, T3700	J-62
41990	Ultra Frame Receiver, Weld Together For Service Body Trucks, 44" Crosstube Only	A-6
41990-07	Ultra Frame Receiver, Weld Together For Service Body Trucks, 44" Crosstube w/Short 7" Side Bracket Kit #4907	A-6
41990-16	Ultra Frame Receiver, Weld Together For Service Body Trucks, 44" Crosstube w/Long 16" Side Bracket Kit #4916	A-6
41991	Ultra Frame Receiver, Weld Together For Service Body Trucks, 62" Crosstube Only	A-6
41991-07	Ultra Frame Receiver, Weld Together For Service Body Trucks, 62" Crosstube w/Short 7" Side Bracket Kit #4907	A-6
41991-16	Ultra Frame Receiver, Weld Together For Service Body Trucks, 62" Crosstube w/Long 16" Side Bracket Kit #4916	A-6
4210	Pintle Hook Accessories, Lunette Ring Lock, Zinc	B-16
42-106856	LED Stud Mount Amber, 2 Diode, 12" Brown/White Wires	K-34
42-106858	LED Surface Mount Red 13" Waterproof ID Light Bar, 3 Diode, 60" Brown/White Wires	K-48
42-107045	LED Stud Mount Red, 2 Diode, 12" Brown/White Wires	K-34
42250	Ball Cover, 1-7/8" & 2", Black	B-22
42250-012	Ball Cover, 1-7/8" & 2", Black, Display Pkg. (12 pack)	B-22
42251	Ball Cover, 2-5/16", Black	B-22
42251-012	Ball Cover, 2-5/16", Black, Display Pkg. (12 pack)	B-22
423025	Over 80" Submersible Taillight, Left/Roadside (Black)	K-24
42-30-401	LED 2" Round Red	K-31
42-30-402	LED 2" Round Amber	K-31
423075	Over 80" Submersible Taillight, Right/Curbside (Black)	K-24
42-31-403	LED 2-1/2" Round Red w/Grommet & Pigtail Reflex	K-31
42-31-404	LED 2-1/2" Round Amber w/Grommet & Pigtail Reflex	K-31
4234	Safety Chain Loop, Class I, 2,000 lbs.	A-16
42-37-401	37 Series LED Red	K-32
42-37-402	37 Series LED Amber	K-32
42-38-033	Clearance Light LED #38 Red with Black Base with Pigtail	K-36
42-38-034	Clearance Light LED #38 Amber with Black Base with Pigtail	K-36

PART NO.	DESCRIPTION	PAGE #
42-38-035	Clearance Light LED #38 Red/Amber w/Black Base, Self Grounding w/Single Black Wire	K-36
42-42-401	Clearance Light LED #42 Red w/Reflex, Stud Mount	K-36
42-42-402	Clearance Light LED #42 Amber w/Reflex, Stud Mount	K-36
42-59-401	Clearance Light LED #59 Red w/White Base	K-35
42-59-402	Clearance Light LED #59 Amber w/White Base	K-35
42-59-410	Upgrade Kit LED #59 Red	K-35
42-59-412	Upgrade Kit LED #59 Amber	K-35
4280	Ball Mount, 12,000 lbs. GTW, 1-1/4" Ball Hole, 8-1/2" Length, 1" Rise, 2" Drop, Zinc	A-5, B-9
4281	Ball Mount, 12,000 lbs. GTW, 1-1/4" Ball Hole, 8-1/2" Length, 3" Rise, 4" Drop, Zinc	A-5, B-9
4282	Ball Mount, 12,000 lbs. GTW, 1-1/4" Ball Hole, 9-1/2" Length, 5" Rise, 6" Drop, Zinc	A-5, B-9
4283	Ball Mount, 12,000 lbs. GTW, 1-1/4" Ball Hole, 9-1/2" Length, 7" Rise, 8" Drop, Zinc	A-5, B-9
4284	Ball Mount, 12,000 lbs. GTW, 1-1/4" Ball Hole, 12" Length, 1" Rise, 2" Drop, Zinc	A-5, B-9
42-84-410	LED #84 Series Stop, Tail, Turn Light Lens Upgrade Module Red w/Connector and Lens Screws	K-3
42-84-412	LED #84 Series Turn Light Lens Upgrade Module Amber w/Connector and Lens Screws	K-3
42-84-414	LED #84 Backup Lens Module Red Reflex w/Clear Center w/Bulb Socket Plug	K-3
42-84-415	84 LED BU UPGR MOD	K-3
4285	Ball Mount, 12,000 lbs. GTW, 1-1/4" Ball Hole, 12" Length, 3" Rise, 4" Drop, Zinc	A-5, B-9
42-86-101	Taillight LED #86 Single Stop, Tail, Turn with Black Base	K-4
42-86-104	Taillight LED #86 Amber Turn with Black Base	K-4
42-86-410	LED Wrap-Around Clearance Light Upgrade Module Red	K-3/4
42-86-412	LED Wrap-Around Clearance Light Upgrade Module Amber	K-3/4
42-99-215	Waterproof ID Bar LED, Red	K-48
42-99-401	Clearance Light LED #99 Red	K-34
42-99-402	Clearance Light LED #99 Amber	K-34
42-S	4-Way Metal Connector, Car End - Male	C-31
43031	Replacement Part, Pin & Chain Assy. for Pintle Hooks, 5/16" Dia. x 2-3/8"	B-15
43805W0317	Coupler, A-Frame Wedge Latch - 8K	J-39
43-S	4-Way Metal Connector, Trailer End - Female	C-31
44-00-002	Pigtail - 2 Wire w/ 6-1/2" Wire Lead	K-26, K-31/32, K-34, K-37/38, K-54
44-00-003	Pigtail - 3 Wire Sealed	K-8, K-10/11, K-21, K-26
44-01-001	Taillight Sealed Stop, Tail, Turn 4" Round	K-21
44-01-020	Grommet - Sealed 4" Round Taillight	K-9, K-21
44-01-031	Taillight Sealed Stop, Tail, Turn 4" Round with Grommet and Standard Pigtail	K-21
44-06-001	Taillight Sealed Stop, Tail, Turn 6" Oblong	K-21
44-06-002	Taillight Sealed Amber Turn 6" Oblong	K-21
44-06-003	Taillight Sealed Clear Backup 6" Oblong	K-21
44-06-020	Grommet - Sealed 6" oblong Taillight	K-8, K-10/11, K-21, K-26
44-06-031	Taillight Sealed Stop, Tail, Turn 6" Oblong with Grommet and Standard Pigtail	K-21
44-06-032	Taillight Sealed Amber Turn 6" Oblong with Grommet and Standard Pigtail	K-21
44-06-033	Taillight Sealed Clear Backup 6" Oblong with Grommet and Standard Pigtail	K-21
44-06-041	Taillight Sealed Stop, Tail, Turn 6" Oblong with Grommet and 90° Pigtail	K-21
44-06-042	Taillight Sealed Amber Turn 6" Oblong with Grommet and 90° Pigtail	K-21
44-06-043	Taillight Sealed Clear Backup 6" Oblong with Grommet and 90° Pigtail	K-21
44125W0317	Coupler, A-Frame Wedge Latch - 12.5K	J-39
44133	Quick-Link Chain Hook-Up, 3,500 lbs., 3/8"	M-26
44140	Safety Chain, Class III GVWR 5,000 lbs. 48", 1/4" Proof Coil, Grade 30 S-Hook, Both Ends	M-25
44150	Safety Chain S-Hook, Class I, Breaking Strength 2,000 lbs.	M-26

NUMERICALS

PART NO.	DESCRIPTION	PAGE #
44-15-001	Taillight Surface Mount #15 Stop, Tail, Turn	K-20
44-15-005	Interior Dome Light with Switch	K-60
44150W0317	Coupler, A-Frame Wedge Latch - 15K - Round Jack Hole	J-39
44150WH301	Coupler, A-Frame Wedge Latch - 15K - Round Jack Hole - Bolt-On - Zinc	J-39
44150WQ317	Coupler, A-Frame Wedge Latch - 15K - Square Jack Hole - Primed	J-39
44153	Safety Chain S-Hook, Class III Breaking Strength 5,000 lbs.	M-26
44154	Clevis Slip Hook w/Latch, Grade 43, 1/4"	M-26
44155	Clevis Slip Hook w/Latch, Grade 43, 5/16"	M-26
44156	Clevis Slip Hook w/Latch, Grade 43, 3/8"	M-26
44157	Clevis Slip Hook w/Latch, Grade 43, 1/2"	M-26
44159	Clevis Slip Hook w/Latch, Grade 70, 5/16"	M-26
44163	Clevis Slip Hook w/Latch, Grade 70, 1/4"	M-26
44164	Clevis Slip Hook w/Latch, Grade 70, 3/8"	M-26
44200	Recessed Rope Ring, 1,200 lbs. for 3/8" Plywood	M-26
4420000317	Coupler Plate, 20,000 lbs. Cast - Primed	J-39
44201	Recessed Rope Ring, 1,200 lbs., 10 Ga. Steel D-Ring, .225 Dia., Zinc	M-26
44202	Recessed Rope Ring w/Trim Ring, 1,000 lbs., 16 Ga. Steel, Zinc	M-26
44203	Replacement Part, Plastic Trim Ring For #44202	M-26
44209	Recessed Floor/Wall Tie Down Ring, 1/8" Plate Steel, 5,000 lbs.	M-26
4425000317	Coupler Plate, 25,000 lbs. Cast - Primed	J-39
44-30-001	Clearance Light Sealed Module, #30 Red	K-38
44-30-002	Clearance Light Sealed Module, #30 Amber	K-38
44-30-020	Grommet - 2" Round Clearance/Marker Light	K-31, K-38
44-30-031	Clearance Light Sealed #30 Red with Grommet and 6-1/2" Pigtail	K-38
44-30-032	Clearance Light Sealed #30 Amber with Grommet and 6-1/2" Pigtail	K-38
44305F0317	F2 A-Frame Coupler, Ball Size 2-5/16", Rating 10,000 lbs.	J-31
44305R0317	Coupler, A-Frame, 10,000 lbs., Class IV, Prime, 2-5/16" Ball	J-48
44305R0500	Coupler, A-Frame, 10,000 lbs., Class IV, Oily, 2-5/16" Ball	J-48
44-31-001	Clearance Light Sealed Module, #31 Red	K-38
44-31-002	Clearance Light Sealed Module, #31 Amber	K-38
44-31-020	Grommet - 2-1/2" Round Clearance Light	K-31, K-38
44-31-031	Clearance Light Sealed #31 Red with Grommet and 6-1/2" Pigtail	K-38
44-31-032	Clearance Light Sealed #31 Amber with Grommet and 6-1/2" Pigtail	K-38
44314R0303	Coupler, A-Frame, 14,000 lbs., Class IV, Black Paint, 2-5/16" Ball	J-48
4434	Gooseneck Rail Kit, GM	G-13/18
4435	Gooseneck Rail Kit, Dodge	G-13/18
4436	Gooseneck Rail Kit, Toyota	G-13/18
4437	Gooseneck Rail Kit, Ford	G-13/18
44-37-020	Clearance Light Base, Black 2" Snap-Lock, Open Back	K-26, K-32, K-37
44-37-031	Clearance Light Sealed #37 Red with Black Base and Wire	K-37
44-37-032	Clearance Light Sealed #37 Amber with Black Base and Wire	K-37
4438	Gooseneck Rail Kit, Dodge	G-13/18
44-38-031	Clearance Light Sealed #38 Red with Black Base and Wire Assembly	K-37
44-38-032	Clearance Light Sealed #38 Amber with Black Base and Wire Assembly	K-37
4439	Gooseneck Rail Kit, Dodge	G-13/18
44-39-001	Clearance Light Mini #39 Red	K-45
4440	Gooseneck Rail Kit, GM	G-13/18
44-40-004	Fender Mount Clearance Light #40 Red/Amber with Black Base and Screws	K-46
44-41-001	Clearance/Marker Light Red Rectangle Chrome Base	K-44
4445	Gooseneck Rail Kit, GM	G-13/18
4446	Gooseneck Rail Kit, Dodge	G-13/18
4448	Gooseneck Rail Kit, Ford	G-13/18
4449	Gooseneck Rail Kit, Ford	G-13/18
4454	Gooseneck Rail Kit, GM	G-13/18
4456	Gooseneck Rail Kit, GM	G-13/18

PART NO.	DESCRIPTION	PAGE #
45018	Titan®, Receiver Extension, 2-1/2" to 2" Extension, 41" Length 5000 lbs. WC & 7500 lbs. WD, 48" Length 4000 lbs. WC & 6000 lbs. WD	A-11, B-13
45122	Titan®, Ball Mount, 14,000 lbs. GTW, 1-1/4" Ball Hole, 9-3/4" Length, 1-1/2" Rise, 3" Drop, Black	A-11, B-9
45123	Titan®, Ball Mount, 13,000 lbs. GTW, 1-1/4" Ball Hole, 10" Length, 3-1/2" Rise, 5" Drop, Black	A-11, B-9
45144	Titan®, Receiver Tube Cover	B-22
45156	Titan®, 2-1/2" Receiver Pintle Hook Mounting Plate, 7-3/4" Shank, 6" x 5" Plate Size, 12,000/1,200 lbs.	B-15
45291	Titan®, Ball Mount, 13,000 lbs. GTW, 1-1/4" Ball Hole, 10-1/2" Length, 7-3/4" Drop, Black (Use in Drop Position Only)	A-11, B-9
45292	Titan®, Receiver Extension, 2-1/2" to 2" Extension, 24" Length 6000 lbs. WC & 8000 lbs. WD, 34" Length 4500 lbs. WC & 6000 lbs. WD	A-11, B-13
45294	Titan®, 2-1/2" Receiver Pintle Hook Mounting Plate, 8-1/2" Shank, 7-1/4" x 5" Plate Size, 18,000/2,000 lbs.	B-15
45322	Titan®, Ball Mount, 18,000 lbs. GTW/2000 lbs. TW, 1-1/4" Ball Hole, 10" Length, 1-1/2" Rise, 3" Drop, Black	A-11, B-9
45323	Titan®, Ball Mount, 18,000 lbs. GTW/2000 lbs. TW, 1-1/4" Ball Hole, 10" Length, 3-1/2" Rise, 5" Drop, Black	A-11, B-9
45325	Titan®, Tri-Ball Ball Mount, 2-1/2" Sq. Hollow Shank w/Black 1-7/8", 2", & 2-5/16" Balls, Black	A-11, B-12
4655	9/16" Drill Bit w/Special 1/2" Reduced Shank for Use w/1/2" Drills	O-3
47-01-001	Taillight LED Stop, Tail, Turn 4" Round	K-9
47-01-031	4" Round LED Tail Lamp with Grommet and Plug	K-9
47-05-151	LAMP LED COURTESY CLEAR	K-26
47-06-001	Taillight LED Stop, Tail, Turn 6" Oval Vertical Mount	K-10
47-06-004	Taillight LED Stop, Tail, Turn 6" Oval Horizontal Mount	K-10
47-06-005	6" Oval Mid-Turn Amber Light	K-8
47-06-031	6" Oval LED Tail Lamp w/Grommet and Plug, Vertical Mount	K-10
47-06-034	6" Oval LED Tail Lamp w/Grommet and Plug, Horizontal Mount	K-10
47-06-401	Taillight LED Stop, Tail, Turn 6" Oval Vertical Mount	K-10
47-06-404	Taillight LED Stop, Tail, Turn 6" Oval Horizontal Mount	K-10
47-07-001	LED Stop/Tail/Turn Light Surface Mount #07 Series	K-7
47-07-002	LED Stop/Tail/Turn Light Surface/Horizontal Mount #07 Series w/ License Light & Bracket	K-7
47-07-003	LED Stop/Tail/Turn Light Surface Mount #07 Series	K-7
47-07-010	Replacement Part, Lens for #47-07-001	K-7
47-07-011	Replacement Part, Lens for #47-07-002	K-7
47-07-012	Replacement Part, Lens for #47-07-003	K-7
47-07-013	Replacement Part, Lens for #47-07-100	K-7
47-07-100	LED Stop/Tail/Turn Light Surface/Horizontal Mount #07 Series w/ License Light & Bracket	K-7
47-106020	Chrome Bezel	K-33
47-106851	LAMP SMCL LED AMBER STUD MTD;W/12" BRN WIRE	K-34
47-106852	LED Stud Mount Amber 162" 1 Wire Pigtail	K-34
47-106853	AMBER SIDE MARKER LAMP	K-33
47-106854	Clearance Light LED Clear Lens w/Amber Diodes	K-33
47-106856	Clearance Light LED Amber w/Stud Mounting	K-34
47-106857	LED Stud Mount Amber 162" 2 Wire Pigtail	K-34
47-106858	LED ID Bar 60" 2 Wire Pigtail	K-48
47-107043	Clearance Light LED Red w/Stud Mounting	K-34
47-107044	LED Stud Mount Red 96" 1 Wire Pigtail	K-34
47-107045	Clearance Light LED Red w/Stud Mounting	K-34
47-107046	LED Stud Mount Red 96" 2 Wire Pigtail	K-34
47-107047	RED SIDE MARKER LAMP	K-33
47-107048	Clearance Light LED Clear Lens w/Red Diodes	K-33
47-203667	LED Grommet Mt Amber	K-34
47-203668	LED Grommet Mt Red	K-34
47-222012	Clearance Light LED Amber w/Reflex w/Black Base	K-33
47-222014	Clearance Light LED Red w/Reflex w/White Base	K-33
47-222015	Clearance Light LED Amber w/Reflex w/White Base	K-33
47-30-001	Clearance Light LED Module, #30 Red	K-31
47-30-002	Clearance Light LED Module, #30 Amber	K-31
47-30-031	Clearance Light LED #30 Red with Grommet and Plug	K-31
47-30-032	Clearance Light LED #30 Amber with Grommet and Plug	K-31

NUMERICALS

PART NO.	DESCRIPTION	PAGE #
47-30-401	Clearance Light LED Module, #30 Red	K-31
47-30-402	Clearance Light LED Module, #30 Amber	K-31
47-31-001	Clearance Light LED Module, #31 Red	K-31
47-31-002	Clearance Light LED Module, #31 Amber	K-31
47-31-003	Clearance Light LED Module, #31 Red with Reflex	K-31
47-31-004	Clearance Light LED Module, #31 Amber with Reflex	K-31
47-31-031	Clearance Light LED #31 Red with Grommet with 6-1/2" Pigtail	K-31
47-31-032	Clearance Light LED #31 Amber with Grommet with 6-1/2" Pigtail	K-31
47-31-033	Clearance Light LED #31 Red with Reflex Lens with Grommet with 6-1/2" Pigtail	K-31
47-31-401	Clearance Light LED Module, #31 Red	K-31
47-31-402	Clearance Light LED Module, #31 Amber	K-31
47-31-403	Clearance Light LED Module, #31 Red with Reflex	K-31
47-31-404	Clearance Light LED Module, #31 Amber with Reflex	K-31
47-37-001	Clearance Light LED Module, #37 Red	K-32
47-37-002	Clearance Light LED Module, #37 Amber	K-32
47-37-005	Clearance Light Module LED #37 Red	K-32
47-37-006	Clearance Light Module LED #37 Amber	K-32
47-37-031	Red 2" LED Rectangular Marker/Clearance Lamp	K-32
47-37-032	Amber 2" LED Rectangular Marker/Clearance Lamp	K-32
47-37-401	Clearance Light LED Module, #37 Red	K-32
47-37-402	Clearance Light LED Module, #37 Amber	K-32
47-38-001	Clearance Light LED Module, #38 Red	K-36
47-38-002	Clearance Light LED Module, #38 Amber	K-36
47-38-004	Clearance Light Module LED #38 Red/Amber	K-36
47-38-005	Clearance Light Module LED #38 Red	K-36
47-38-006	Clearance Light Module LED #38 Amber	K-36
47-38-033	Clearance Light LED #38 Red with Black Base with Pigtail	K-36
47-38-034	Clearance Light LED #38 Amber with Black Base with Pigtail	K-36
47-38-035	Clearance Light LED #38 Red with Chrome Base with Pigtail	K-36
47-38-036	Clearance Light LED #38 Amber with Chrome Base with Pigtail	K-36
47-38-401	Clearance Light LED Module, #38 Red	K-36
47-38-402	Clearance Light LED Module, #38 Amber	K-36
47-42-001	Clearance Light LED #42 Red w/Reflex, Stud Mount	K-36
47-42-002	Clearance Light LED #42 Amber w/Reflex, Stud Mount	K-36
47-42-401	Clearance Light LED #42 Red w/Reflex, Stud Mount	K-36
47-42-402	Clearance Light LED #42 Amber w/Reflex, Stud Mount	K-36
47-54-001	Narrow Rail S,T,T Red w/Reflex	K-8
47-54-002	Narrow Rail ID Bar LED Red	K-48
47-54-003	Narrow Rail ID Bar LED Amber	K-48
47-58-001	Clearance Light LED #58 Red	K-35
47-58-002	Clearance Light LED #58 Amber	K-35
47-58-031	Clearance Light LED #58 Red with Pigtail	K-35
47-58-032	Clearance Light LED #58 Amber with Pigtail	K-35
47-59-001	Clearance Light LED #59 Red w/White Base	K-35
47-59-002	Clearance Light LED #59 Amber w/White Base	K-35
47-59-010	Clearance Light LED Replacement Lens Red	K-35
47-59-012	Clearance Light LED Replacement Lens Amber	K-35
47-59-401	Clearance Light LED #59 Red w/White Base	K-35
47-59-402	Clearance Light LED #59 Amber w/White Base	K-35
47-59-410	Upgrade Kit LED #59 Red	K-35
47-59-412	Upgrade Kit LED #59 Amber	K-35
4769-28	SPRING-RATCHET-TWO	J-62
47-84-001	Taillight Horizontal Mount with Red LED, Incandescent Backup with Colonial White Base	K-5
47-84-002	Taillight Horizontal Mount with Red/Red LED, Incandescent Backup with Colonial White Base	K-6
47-84-003	Taillight Horizontal Mount with Red/Amber LED, Incandescent Backup with Colonial White Base	K-6
47-84-005	Taillight Horizontal Mount with Red/Amber LED, Incandescent Backup with Black Base	K-6
47-84-008	Taillight Horizontal Mount with Red LED, Incandescent Backup with Black Base	K-5
47-84-009	Taillight Horizontal Mount with Red/Red LED, Incandescent Backup with Black Base	K-6

PART NO.	DESCRIPTION	PAGE #
47-84-026	LED #84 Backup Lens Module Clear w/Bulb Socket Plug	K-3
47-84-101	Taillight Horizontal Mount with Red LED, Incandescent Backup, Red LED with Colonial White Base	K-6
47-84-103	Taillight Horizontal Mount with Red LED, Incandescent Backup, Red LED with Black Base	K-6
47-84-104	LED Taillight #84 Recessed Triple Long Horizontal Mount, Red, Backup, Amber, Black	K-6
47-84-410	LED #84 Series Stop, Tail, Turn Light Lens Upgrade Module Red w/Connector and Lens Screws	K-3
47-84-412	LED #84 Series Turn Light Lens Upgrade Module Amber w/Connector and Lens Screws	K-3
47-84-414	LED #84 Backup Lens Module Red Reflex w/Clear Center w/ Bulb Socket Plug	K-3
47-84-420	LED #84 Series Stop, Tail, Turn Light Lens Module Red with Wires	K-4/6
47-84-422	LED #84 Series Turn Light Lens Module Amber with Wires	K-4/6
47-84-424	LED Backup Light Lens Module Red Reflex w/Clear Center w/ Wires	K-5
47-84-518	Taillight Red & Amber LED with Black Base	K-5
47-84-522	Taillight Horizontal Mount with Red LED, Incandescent Center Backup, Red LED with Black Base	K-6
47-84-527	Taillight Red & Red LED with Black Base	K-5
47-84-529	Taillight Red LED & Incandescent Red with Red Insert & Black Base	K-5
47-84-530	Taillight Horizontal Mount with Red/Red LED, Incandescent Backup with White Base	K-6
47-84-540	Taillight Horizontal Mount with Red LED, Incandescent Backup with White Base	K-5
47-84-546	Taillight Red & Amber LED with White Base	K-5
47-84-555	Taillight Vertical Mount with Red LED, Incandescent Backup, Red LED with White Base	K-6
47-84-610	Taillight #84 LED Surface Mount Red/Red, Black Base	K-5
47-84-612	Taillight #84 LED Surface Mount Red/Amb, Black Base	K-5
47-84-613	Taillight #84 LED Surface Mount Red/LED w/Backup, Black Base	K-5
47-84-711	Enhanced Height Incandescent Backup Lens Only, Red Reflex w/ Clear Center - Red Border	K-3, K-5/6
47-84-712	Enhanced Height Incandescent Lens Only - Red Reflex w/Red Center - Red Border	K-3, K-5/6
47-85-002	Taillight Horizontal Mount with Red/Red LED, Incandescent Backup with Chrome Base	K-6
47-85-004	Taillight Horizontal Mount with Red/Amber LED, Incandescent Backup with Chrome Base	K-6
47-85-005	Taillight Red/Red LED, Incandescent Red with Red Insert & Chrome Base	K-6
47-85-611	Taillight #84 LED Surface Mount Red/Red Chrome Base	K-5
47-85-614	Taillight #84 LED Surface Mount Red/LED, w/Backup, Chrome Base	K-5
47-85-615	Taillight #85 LED Surface Mount Red/Amber, Chrome Base	K-5
47-85-711	Enhanced Height Incandescent Backup Lens Only, Red Reflex w/ Clear Center - Chrome Border	K-3
47-85-712	Enhanced Height Incandescent Lens Only - Red Reflex w/Red Center - Chrome Border	K-3
47-86-001	Taillight LED #86 Single Stop, Tail, Turn with Colonial White Base	K-4
47-86-004	Taillight LED #86 Amber Turn with Colonial White Base	K-4
47-86-005	Clearance Light LED #86 Wrap-Around Red with Colonial White Base	K-4
47-86-006	Clearance Light LED #86 Wrap-Around Amber with Colonial White Base	K-4
47-86-101	Taillight LED #86 Single Stop, Tail, Turn with Black Base	K-4
47-86-104	Taillight LED #86 Amber Turn with Black Base	K-4
47-86-202	Clearance Light LED #86 Wrap-Around Red with Black Base	K-4
47-86-203	Clearance Light LED #86 Wrap-Around Amber with Black Base	K-4
47-86-410	LED Wrap-Around Clearance Light Upgrade Module Red	K-3/4
47-86-412	LED Wrap-Around Clearance Light Upgrade Module Amber	K-3/4
47-99-004	ID Light Bar LED Red	K-48
47-99-005	Clearance Light LED #99 Red w/Type 302 Stainless Steel Hardware	K-32
47-99-006	Clearance Light LED #99 Amber w/Type 302 Stainless Steel Hardware	K-32
47-99-034	ID Light Bar LED Red	K-48
47-99-215	Waterproof ID Bar LED, Red	K-48

NUMERICALS

PART NO.	DESCRIPTION	PAGE #
48-84-008	Taillight Horizontal Mount with Red LED, Incandescent Backup with Black Base	K-5
48-84-009	Taillight Horizontal Mount with Red/Red LED, Incandescent Backup with Black Base	K-6
48-84-527	Taillight Red & Red LED with Black Base	K-5
48-84-529	Taillight Red LED & Incandescent Red with Red Insert & Black Base	K-5
48-84-711	Enhanced #84/86 Incandescent Backup Lens	K-3, K-5/6
48-84-712	Enhanced Height Incandescent Lens Only - Red Reflex w/Red Center - Red Border	K-3, K-5/6
48-85-711	Enhanced Height Incandescent Backup Lens Only, Red Reflex w/ Clear Center - Chrome Border	K-3
48-85-712	Enhanced Height Incandescent Lens Only - Red Reflexw/Red Center - Chrome Border	K-3
48-86-101	Taillight LED #86 Single Stop, Tail, Turn with Black Base	K-4
48-86-104	Taillight LED #86 Amber Turn with Black Base	K-4
48-86-202	Clearance Light LED #86 Wrap-Around Red with Black Base	K-4
48-86-203	Clearance Light LED #86 Wrap-Around Amber with Black Base	K-4
4907	Ultra Frame Receiver, Weld Together For Service Body Trucks Short 7" Side Bracket Kit Only	A-6
49080	Pro Series Gooseneck (Requires Rails & Installation Kit #30035)	G-11
49131	Quick-Link Chain Hook-Up, 3,500 lbs., 5/16"	M-26
49132	Quick-Link Chain Hook-Up, 3,500 lbs., 1/4"	M-26
49134	Quick-Link Chain Hook-Up, 5,000 lbs., 7/16"	M-26
49135	Quick-Link Chain Hook-Up, 10,000 lbs., 1/2"	M-26
49137	Safety Chain, Class I GVWR 2,000 lbs. 48", 3/16" Proof Coil, Grade 30 S-Hook, Both Ends	M-25
49138	Safety Chain, Class II GVWR 3,500 lbs. 24", 1/4" Proof Coil, Grade 30 S-Hook, One End	M-25
49141	Safety Chain, Class III GVWR 5,000 lbs. 30", 1/4" Proof Coil, Grade 30 S-Hook, One End	M-25
49147	Safety Chain, Class IV GVW 16,200 lbs. 35", 1/2" Proof Coil, 3/8" Clevis Slip Hook w/Latch, High Test Grade 43	M-25
49148	Safety Chain, Class IV GVW 7,600 lbs. 32", 5/16" Proof Coil, Grade 30, 5/16" Clevis Slip Hook w/Latch	M-25
49149	Safety Chain, Class IV GVW 10,600 lbs. 36", 1/2" Proof Coil, Grade 30, 3/8" Clevis Slip Hook w/Latch	M-25
49152	Safety Chain S-Hook, Class IV Breaking Strength 7,600 lbs.	M-26
4916	Ultra Frame Receiver, Weld Together For Service Body Trucks Long 16" Side Bracket Kit Only	A-6
49568	Pro Series™ RB2 Wt. Dist. Kit w/#63970 Shank, 10,000 lbs. (GTW), 600 lbs. (TW)	D-14
49568-020	Pro Series™ RB2 Wt. Dist. Kit w/#63970 Shank, 10,000 lbs. (GTW), 600 lbs. (TW) (20 pack)	D-14
49569	Pro Series™ RB2 Wt. Dist. Kit w/#63970 Shank, 10,000 lbs. (GTW), 800 lbs. (TW)	D-14
49569-020	Pro Series™ RB2 Wt. Dist. Kit w/#63970 Shank, 10,000 lbs. (GTW), 800 lbs. (TW) (20 pack)	D-14
49570	Pro Series™ RB2 Wt. Dist. Kit w/#63970 Shank, 12,000 lbs. (GTW), 1,200 lbs. (TW)	D-14
49570-020	Pro Series™ RB2 Wt. Dist. Kit w/#63970 Shank, 12,000 lbs. (GTW), 1,200 lbs. (TW) (20 pack)	D-14
49581	Pro Series™ RB3 Wt. Dist. Kit w/Shank, 2-5/16" Chrome Hitch Ball, Chains & Hardware, 10,000 lbs. (GTW), 550 lbs. (TW)	D-14
49581-020	Pro Series™ RB3 Wt. Dist. Kit w/Shank, 2-5/16" Chrome Hitch Ball, Chains & Hardware, 10,000 lbs. (GTW), 550 lbs. (TW) (20 pack)	D-14
49582	Pro Series™ RB3 Wt. Dist. Kit w/Shank, 2-5/16" Chrome Hitch Ball, Chains & Hardware, 10,000 lbs. (GTW), 750 lbs. (TW)	D-14
49582-020	Pro Series™ RB3 Wt. Dist. Kit w/Shank, 2-5/16" Chrome Hitch Ball, Chains & Hardware, 10,000 lbs. (GTW), 750 lbs. (TW) (20 pack)	D-14
49583	Pro Series™ RB3 Wt. Dist. Kit w/Shank, 2-5/16" Chrome Hitch Ball, Chains & Hardware, 10,000 lbs. (GTW), 1000 lbs. (TW)	D-14
49583-020	Pro Series™ RB3 Wt. Dist. Kit w/Shank, 2-5/16" Chrome Hitch Ball, Chains & Hardware, 10,000 lbs. (GTW), 1000 lbs. (TW) (20 pack)	D-14
49585	Pro Series™ Trunnion Wt. Dist. Kit w/#63970 Shank, 10,000 lbs. (GTW), 600 lbs. (TW)	D-13
49585-020	Pro Series™ Trunnion Wt. Dist. Kit w/#63970 Shank, 10,000 lbs. (GTW), 600 lbs. (TW) (20 pack)	D-13

PART NO.	DESCRIPTION	PAGE #
49586	Pro Series™ Trunnion Wt. Dist. Kit w/#63970 Shank, 10,000 lbs. (GTW), 800 lbs. (TW)	D-13
49586-020	Pro Series™ Trunnion Wt. Dist. Kit w/#63970 Shank, 10,000 lbs. (GTW), 800 lbs. (TW) (20 pack)	D-13
49587	Pro Series™ Trunnion Wt. Dist. Kit w/#63970 Shank, 12,000 lbs. (GTW), 1,200 lbs. (TW)	D-13
49587-020	Pro Series™ Trunnion Wt. Dist. Kit w/#63970 Shank, 12,000 lbs. (GTW), 1,200 lbs. (TW) (20 pack)	D-13
49802	Fold Down License Plate Holder	A-15
49803	Assortment Installation Hardware Kit	A-16
49901	Pro Series™ Complete RB Wt. Dist. Kit w/Shank, Friction Sway Control, 2-5/16" Chrome Hitch Ball, Sway Control Ball, Chains & Hardware, 10,000 lbs. (GTW), 550 lbs. (TW)	D-13
49902	Pro Series™ Complete RB Wt. Dist. Kit w/Shank, Friction Sway Control, 2-5/16" Chrome Hitch Ball, Sway Control Ball, Chains & Hardware, 10,000 lbs. (GTW), 750 lbs. (TW)	D-13
49903	Pro Series™ Complete RB Wt. Dist. Kit w/Shank, Friction Sway Control, 2-5/16" Chrome Hitch Ball, Sway Control Ball, Chains & Hardware, 10,000 lbs. (GTW), 1000 lbs. (TW)	D-13
5000-DX	Shoe and Lining Kit - Dexter 12" x 2" - Wheel Set	M-17
500103	Kit -3/8" Plunger Pin Assembly (2, 3, 5K)	J-26
500105	Sidewind Crank Assembly for 170's w/Black Knob	J-8, J-27
500106	Replacement Part, Bevel Gear Kit	J-28
500130	Service Kit -F2 Twin Track Wheel Replacement	J-29
500131	Service Kit -F2 Wide Track Wheel Replacement	J-29
500132	Service Kit -F2 Twin Track Wheel Wedge	J-29
500133	Service Kit -F2 Wide Track Wheel Wedge	J-29
500134	Service Kit -F2 Handle/Crank Kit	J-29/30
500135	Service Kit -F2 Gearbox Cover Replacement	J-29/30
500136	Service Kit -F2 Pull Pin Replacement	J-29/30
500137	KIT-F2 BEARING REPLACEMENT	J-29/30
500138	Service Kit -F2 Twin Track Wheel	J-29
500148	Replacement Part, Topwind Crank, 9" Radius w/Black "Tear Drop" Knob For 7000 lbs. Jacks	J-8, J-27
500153	JACK-45K TANDEM LG W/OMOUNT	J-20
500154	JACK-45K TANDEM LG W/OMOUNT	J-20
500156	Replacement Part, Gear Kit 7000 lbs.	J-28
500158	Fifth Wheel RV Landing Gear System, 6.5K Static, 4K Lift, Single Drive, Includes Secondary Gearbox, Mounting Hardware & Adjustable Cross Shaft (Motor, Switch & Wiring Harness Sold Separately)	J-21
500162	Fifth Wheel RV Landing Gear System, 8K Static, 4K Lift, Single Drive, Includes Secondary Gearbox, Mounting Hardware & Adjustable Cross Shaft Spring Loaded Drop Leg Pins (Motor, Switch & Wiring Harness Sold Separately)	J-21
500170	Fifth Wheel RV Landing Gear System, 10K Static, 7K Lift, Dual Drive, Output Motors Preassembled to Jacks, Includes Two Switches & Panel, Wiring Harness, Mounting Hardware & Spring Loaded Drop Leg Pins	J-22
500161	Fifth Wheel RV Landing Gear System, 10K Static, 10K Lift, Dual Drive, Output Motors Preassembled to Jacks, Includes Two Switches & Panel, Wiring Harness, Mounting Hardware & Spring Loaded Drop Leg Pins	J-22
500171	Sidewind Crank Assembly for 190's, Black	J-8, J-27
500177	Kit, 3/4" Plunger Kit w/J Pin for 180's	J-26
500178	Replacement Part, 1/2" Plunger Pin Assembly for 800-5000 lbs. Jacks	J-26
500180	Replacement Part, Topwind Crank, 6-3/4" Radius w/Red Bulldog Knob For 750-5000 lbs. Jacks	J-8, J-27
500185	Bulldog Powered Drive Tongue Jack, A-Frame, 17" Travel, White Case, Rating 4,000 lbs.	J-4
500186	Bulldog Powered Drive Tongue Jack, A-Frame, 17" Travel, Black Case, Rating 4,000 lbs.	J-4
500187	Bulldog Powered Drive Tongue Jack, A-Frame, 14" Travel, Black Case, Rating 3,500 lbs.	J-3
500188	Bulldog Powered Drive Tongue Jack, A-Frame, 14" Travel, White Case, Rating 3,500 lbs.	J-3
500190	Replacement Part, Removable Disc Foot w/Snapper Pin for Bulldog Powered Drive Tongue Jack	J-4, J-26
500191	Replacement Part, Manual Override Bolt for Bulldog Powered Drive Tongue Jack	J-4

NUMERICALS

PART NO.	DESCRIPTION	PAGE #
500192	Replacement Part, Bottom Cover w/Hardware for Bulldog Powered Drive Tongue Jack	J-4
500193	Replacement Part, Level Assembly w/Hardware for Bulldog Powered Drive Tongue Jack	J-4
500194	Replacement Part, Manual Override Cover for Bulldog Powered Drive Tongue Jack	J-4
500196	Replacement Part, LED Light Assembly for Bulldog Powered Drive Tongue Jack	J-4
500198	Powered Jack, A-Frame, 2.5K	J-4
5002	Shoe and Lining Kit - Dexter 7" x 1-1/4" - Wheel Set	M-17
500205	KIT-GEARBOX COVER REPL.	J-28
500212	Kit, Gear Style III for 180's	J-28
500217	KIT SCREW & NUT-10K (PM NUT)	J-28
500223	Kit, 5,000 lbs. Bearing for 170's	J-28
500224	Kit, 7,000 lbs. Bearing for 190's	J-28
500231	Kit, 5/8" Pull Pin, 3.5" Tall, w/Chain for 170's	J-26
500232	Kit, 5/8" Pull Pin, 4.25" Tall, w/Chain for 190's	J-26
500238	EXIT-PACKET, WELD-ON FE	J-27
500239	Replacement Part, Swivel Trailer Mount, Tubular Male Weld-On For 9/16" Pull Pin, for 2000 lbs. Jacks & 5000 lbs. Topwind Jack Only	J-8, J-27
50024	20K Fifth Wheel Round Tube Slider Unit (Requires Rails & Installation Kit #30035 or #30095 and Head Assembly)	E-6
500240	Replacement Part, Swivel Trailer Mount, Tubular Male Weld-On For 5/8" Pull Pin	J-27
500241	Replacement Part, Swivel Retaining Ring For 800-5000 lbs. Jacks	J-28
500242	PACKET, L-BEND SWI	J-27
500243	Replacement Part, 9/16" Pull Pin w/12-1/4" Chain & Drive Screw For 2000 lbs. Jacks & 5000 lbs. Topwind Jack Only	J-26
500244	Replacement Part, Removable Disc Foot, 2-3/32" Tall w/Snapper Pin for 2000-5000 lbs. Jacks	J-8, J-26
500245	Tongue Jack Caster w/6" Wheel & Pin/Clip, for 2000-5000 lbs. Jacks	J-8, J-25
500246	Red Knob for 150's, 160's & 170's	J-28
500248	Black Knob for 139's, 159's, 170's & 190's	J-28
500250	KIT SCREW/NUT-10K TW (J-28
500251	Kit, 2,000 lbs. Bearing for 150's	J-28
500256	Replacement Part, Sidewind Crank Kit, Handle, 5-51/64" Radius Assembly & Gear 2000 lbs. Jacks	J-8, J-27
5002581360	Kit-Gear for 190's	J-28
500265	F2 REMOV. TT Wheel Assembly	J-31
500266	F2 REMOV. WT Wheel Assembly	J-31
500267	F2 REMOV. Foot Assembly	J-31
500270	Replacement Part, 8K Dropleg & Pin	J-26
500277	Kit-F2 3x4 Mount w/Hardware	J-29
500285	Replacement Part, 12,000 lbs. 2 Speed Sun Gear	J-17, J-28
500286	Replacement Part, Mounting Hardware for Jacks	J-35
500289	Replacement Part, Repair Kit (BX1), Includes Handle Assembly, Locking Cam, Grease Fitting, Grooved Pin, Flanged Bushing & Torsion Spring	J-43
5003	Shoe and Lining Kit - Dexter 10" x 2-1/4" - Wheel Set	M-17
50040	Fifth Wheel Custom Quick Install Brackets	E-20/23
50040-58	Fifth Wheel Custom Quick Install Kit (Includes #50040 & #58058)	E-20/23
50042	Fifth Wheel Custom Quick Install Brackets	E-20/23
50042-58	Fifth Wheel Custom Quick Install Kit (Includes #50042 & #58058)	E-20/23
50043	Fifth Wheel Custom Quick Install Brackets	E-20/23
50043-58	Fifth Wheel Custom Quick Install Kit (Includes #50043 & #58058)	E-20/23
50057	Gooseneck Lock	G-11, L-4
50059	Fifth Wheel Custom Quick Install Brackets	E-20/23
50059-58	Fifth Wheel Custom Quick Install Kit (Includes #50059 & #58058)	E-20/23
50064	Fifth Wheel Custom Quick Install Brackets	E-20/23
50064-24	Fifth Wheel Custom Quick Install Kit (Includes #50064 & #30124)	E-20/23
50064-58	Fifth Wheel Custom Quick Install Kit (Includes #50064 & #58058)	E-20/23

PART NO.	DESCRIPTION	PAGE #
50066	Fifth Wheel Custom Quick Install Brackets	E-20/23
50066-24	Fifth Wheel Custom Quick Install Kit (Includes #50066 & #30124)	E-20/23
50066-58	Fifth Wheel Custom Quick Install Kit (Includes #50066 & #58058)	E-20/23
50-07-001	7-Way Cable UL Listed Wire (per foot)	C-38
50073	Fifth Wheel Custom Quick Install Brackets	E-20/23
50073-24	Fifth Wheel Custom Quick Install Kit (Includes #50073 & #30124)	E-20/23
50073-58	Fifth Wheel Custom Quick Install Kit (Includes #50073 & #58058)	E-20/23
50081	Fifth Wheel Custom Quick Install Brackets	E-20/23
50081-24	Fifth Wheel Custom Quick Install Kit (Includes #50081 & #30124)	E-20/23
50081-58	Fifth Wheel Custom Quick Install Kit (Includes #50081 & #58058)	E-20/23
50082	Fifth Wheel Custom Quick Install Brackets	E-20/23
50082-24	Fifth Wheel Custom Quick Install Kit (Includes #50082 & #30124)	E-20/23
50082-58	Fifth Wheel Custom Quick Install Kit (Includes #50082 & #58058)	E-20/23
50083	Fifth Wheel Custom Quick Install Brackets	E-20/23
50083-24	Fifth Wheel Custom Quick Install Kit (Includes #50083 & #30124)	E-20/23
50083-58	Fifth Wheel Custom Quick Install Kit (Includes #50083 & #58058)	E-20/23
5009	Shoe and Lining Kit - Dexter 10" x 1-1/2" - Axle Set	M-17
5010	Shoe and Lining Kit - Dexter 12" x 2" 7K - Wheel Set	M-17
50140	Fifth Wheel Custom Quick Install Brackets	E-20/23
50140-24	Fifth Wheel Custom Quick Install Kit (Includes #50140 & #30124)	E-20/23
50140-58	Fifth Wheel Custom Quick Install Kit (Includes #50140 & #58058)	E-20/23
50222	Fifth Wheel King Pin Lock	E-15, L-4
50223	Fifth Wheel Chain Bracket Kit, 18,000 lbs.	E-15
50-57-007	7-Way Metal Connector, Trailer End	C-37
50-57-503	7-Way Metal Connector, Car End	C-37
50-60-001	6-Way Die Cast Connector, Car End	C-35
50-60-003	6-Way Die Cast Connector, Trailer End	C-35
50-61-008	6-Way Molded Trailer End w/ 8' Cable, 3-10 Gauge, 3-14 Gauge	C-36
50-61-104	6-Way Molded Trailer End w/ 4' Cable, 6-14 Gauge	C-36
50-61-106	6-Way Molded Trailer End w/ 6' Cable, 6-14 Gauge	C-36
50-61-108	6-Way Molded Trailer End w/ 8' Cable, 6-14 Gauge	C-36
50-67-001	7-Way Molded Trailer End w/ 6' Cable	C-38
50-67-002	7-Way Molded Trailer End w/ 7' Cable	C-38
50-67-003	7-Way Molded Trailer End w/ 8' Cable	C-38
50-67-004	7-Way Molded Trailer End w/ 9' Cable	C-38
50-67-005	7-Way Molded Trailer End w/ 10' Cable	C-38
50-67-210	Double Ended 7-Way Molded Trailer End w/ 8' Cable	C-38
50-67-408	7-Way Molded Trailer End w/ 8' Cable and Breakaway Switch	C-38
50-67-409	7-Way Molded Trailer End w/ 9' Cable and Breakaway Switch	C-38
50-67-410	7-Way Molded Trailer End w/ 10' Cable and Breakaway Switch	C-38
50-67-503	7-Way Molded Trailer End w/ 8' Cable, 7-Way Metal Car End and Bracket	C-38
50-67-614	7-Way Molded Trailer End w/ 4' Cable	C-43, K-29
50-67-616	7-Way Molded Trailer End w/ 6' Cable	C-43, K-29
50-67-618	7-Way Molded Trailer End w/ 8' Cable	C-43, K-29
50-67-620	7-Way Molded Trailer End w/ 10' Cable	C-43, K-29
50-67-901	Double Ended 7-Way Molded Trailer Cord w/ 6' Cable	C-38
50-767751	6" Red Oval LED Surface Mount Light w/Black Flange Base	K-11
50-767752	6" Red Oval LED Surface Mount Light w/Black Flange Base	K-11
50-77-001	7-Way Plastic Connector, Car End	C-37
50-77-003	7-Way Plastic Connector, Trailer End	C-37
50-77-070	7-Way Mounting Bracket	C-51
50-77-071	7-Way Mounting Bracket	C-51
50-77-074	7-Way / 4-Flat Mounting Bracket	C-51
50-77-075	7-Way / 5-Flat Mounting Bracket	C-51

NUMERICALS

PART NO.	DESCRIPTION	PAGE #
50-77-510	7-Way Molded Trailer End w/ 7' Cable, 7-Way Plastic Car End and Bracket	C-38
50-85-007	Breakaway Switch w/48" Cable and Pin Assembly	M-6
50-85-102	Replacement Part, Battery Box	M-6
50-85-104	Accelerated Battery Charging Device (ABCD)	M-6
5085115	Accessory Part, Post Mount Bracket Kit for Breakaway Kits #50-85-302/#50-85-312/#50-85-313/#50-85-315	M-3/4
50-85-200	Assembled Breakaway System	M-5
50-85-201	Assembled Breakaway System w/ABCD	M-5
50-85-302	Breakaway System	M-4
50-85-312	Breakaway System w/ABCD	M-4
50-85-313	Breakaway System for 1 to 3 Axle Trailers w/Electric Brakes, Includes Battery Box, 5 Amp Battery w/Push to Test LED Test Meter, Integrated Multi-Stage Charger and Breakaway Switch	M-3
50-85-315	Breakaway System for 1 to 3 Axle Trailers w/Electric Brakes, Includes Battery Box, 5 Amp Battery w/Push to Test LED Test Meter and Breakaway Switch	M-3
50-86-004	6-Way Super Sealed Car End w/ 4' Cable	C-36
50-86-007	6-Way Super Sealed Car End w/ 7' Cable	C-36
50-87-004	7-Way Super Sealed Car End w/ 4' Cable	C-37
50-87-007	7-Way Super Sealed Car End w/ 7' Cable	C-37
50-87-009	7-Way Super Sealed Car End w/ 9' Cable	C-37
50-97-407	Right Angle 7-Way Molded Trailer End w/ 7' Cable	C-40
50-97-410	90° Fifth Wheel Adapter Harness, 7-Way Flat Pin Connector Assembly 9 ft., GM, Ford, Dodge, Toyota	C-40/42
50-97-411	90° Fifth Wheel Adapter Harness, 7-Way Flat Pin Connector Assembly 9 ft., Dodge	C-40/42
50-97-412	90° Fifth Wheel Adapter Harness, 7-Way Flat Pin Connector Assembly 9 ft., Toyota	C-40/42
50-98-050	7-Way Blade to 4-Flat Adapter	C-47
50-98-051	7-Way Blade to 6-Way Round Pin (Auxiliary in Center) Adapter	C-47
50-98-052	7-Way Round Pin to 4-Flat Adapter	C-47
50-98-054	6-Way Round Pin to 4-Flat Adapter	C-47
5100	Activator® Electronic Brake Control, for 1 to 2 Axle Trailers, Timed Actuated	H-8
5101-HA	Magnet Kit - Hayes 10" x 1-5/8" & 2-1/4" and 12" x 2", 1994 & Later	M-15/16
5105	Magnet Kit - Hayes 10" x 2-1/4" & 1-5/8", Prior to 1987	M-15/16
5106	Magnet Kit - Dexter 10" x 2-1/4" / Hayes 10" x 2-1/4" & 1-5/8", After Mid 1987 thru 1993	M-15/16
5109	Magnet Kit - Dexter or Hayes 12" x 2", After Late 1987 thru 1993	M-15/16
5113	Magnet Kit - Dexter 10" x 1-1/2" or 7" x 1-1/4", After 4/1990	M-15/16
5114	Magnet Kit - Dexter 12" x 2", 7K Prior to Mid 1985	M-15/16
5118	Magnet Kit - Dexter 10" x 1-1/2", After Mid 1988	M-15/16
5120TEK	Magnet Retaining Ring	M-16
51-20036	4-Flat to 5-Flat Adapter	C-47
5121TEK	Magnet Retaining Clip	M-16
5122	Weld-On Tube Mount for #182524 & #182374	M-16
51-30703	7-Way Blade to 5-Flat Adapter	C-47
51-57-007	7-Way Metal Connector, Trailer End	C-37
51-57-503	7-Way Metal Connector, Car End	C-37
51-60-001	6-Way Die Cast Connector, Car End	C-35
51-60-003	6-Way Die Cast Connector, Trailer End	C-35
51-61-008	6-Way Molded Trailer End w/ 8' Cable, 3-10 Gauge, 3-14 Gauge	C-36
51-67-001	7-Way Molded Trailer End w/ 6' Cable	C-38
51-67-003	7-Way Molded Trailer End w/ 8' Cable	C-38
51-67-210	Double Ended 7-Way Molded Trailer Cord w/ 8' Cable	C-38
51-67-408	7-Way Molded Trailer End w/ 8' Cable and Breakaway Switch	C-38
51-767811	6-Way Car End Tester w/LED Display	O-2
51-77-001	7-Way Plastic Connector, Car End	C-37
51-77-003	7-Way Plastic Connector, Trailer End	C-37
51-86-004	6-Way Super Sealed Car End w/ 4' Cable	C-36
51-86-007	6-Way Super Sealed Car End w/ 7' Cable	C-36
51-87-002	7-Way Super Sealed Car End w/ 2' Cable	C-37
51-87-004	7-Way Super Sealed Car End w/ 4' Cable	C-37
51-87-007	7-Way Super Sealed Car End w/ 7' Cable	C-37

PART NO.	DESCRIPTION	PAGE #
51-97-407	Right Angle 7-Way Molded Trailer End w/ 7' Cable	C-40
51-97-410	90° Fifth Wheel Adapter Harness, 7-Way Flat Pin Connector Assembly 9 ft., GM, Ford, Dodge, Toyota	C-40/42
51-97-411	90° Fifth Wheel Adapter Harness, 7-Way Flat Pin Connector Assembly 9 ft., Dodge	C-40/42
51-97-412	90° Fifth Wheel Adapter Harness, 7-Way Flat Pin Connector Assembly 9 ft., Toyota	C-40/42
51-98-005	4-Flat Car End Tester w/LED Display	O-2
52 0801	Replacement Part, Coupler Repair Kit for Hand Wheel Coupler	J-48
5209	Actuating Lever - Dexter 10" x 2-1/4" R/H	M-16
5210	Actuating Lever - Dexter 10" x 2-1/4" L/H	M-16
5211	Actuating Lever - Hayes 12" x 2" R/H After Late 1987	M-16
5212	Actuating Lever - Hayes 12" x 2" L/H After Late 1987	M-16
5215	Actuating Lever - Dexter 12" x 2" R/H	M-16
5216	Actuating Lever - Dexter 12" x 2" L/H	M-16
5280	Primus™, Envoy® and Pilot® Mounting Kit Bracket	H-10
5298	Envoy®, Digitrac® II and Pilot® Pivot-Mounting Kit	H-10
5304	Return Spring Set - Axle Set	M-18
5305	Return Spring Set - Axle Set	M-18
5306	Return Spring Set - Axle Set	M-18
5307	Return Spring Set - Axle Set	M-18
5320	Hardware Kit - Axle Set	M-18
5330	Hitch Hider Tube Cover, 2" Sq. Receivers w/Built-In 4-Flat Electrical Cover	B-21
5350	Multi-Fit Motor Home Hitch, Fits Frames 24" to 46" Wide, Black, 5,000 lbs. WC, 6,000 lbs. WD	A-14
5351	Receiver Tube Cover, 1-1/4" Sq., Chrome, Metal	B-21
5352	Receiver Tube Cover, 2" Sq., Chrome, Metal	B-21
5353	Hold Down Kit - Axle Set	M-18
5362	Rubber Economy Receiver Tube Cover w/"D" Logo for 1-1/4" Sq. Receivers	B-21
5363	Receiver Tube Cover, 2" Sq., Black, Plastic (1202)	B-21
54001	Replacement Part, Taillight Lens Submersible 80 Series w/8 - Self Tap Screws (#8 x 1/2") for #2423006, #2423008, #2423056, #2423058, #2423283, #2423284	K-23/24
54002	Replacement Part, Taillight Side Lens Submersible Under 80 Series w/4 - Self Tap Screws (#8 x 1/2") for #2423006, #2423056, #2423283, #2423284	K-23
54003	Replacement Part, Taillight Side Lens Submersible Over 80 Series w/4 - Self Tap Screws (#8 x 1/2") for #2423008, #2423058	K-24
54003-040	Economy AG LED Light Kit	C-45, K-27
54003-041	Deluxe AG LED Transport Kit w/Brake Light Function, 7-Pin	C-45, K-27
54004	6" OVAL RED BLK-BASE	K-11
54005	6" OVAL CLEAR UTIL LAMP	K-26
54006	KIT-STT 6" OVAL LED RED	K-11
54006-009	7-Way Molded Trailer End w/ 6' Cable, Artic Blue	C-38
54006-010	7-Way Molded Trailer End w/ 8' Cable, Artic Blue	C-38
5404	Adjusting Screw Kit	M-18
5407	Adjusting Screw Spring - Axle Set	M-18
54-18137	4, 5 and 6-Way Round Mounting Bracket (Includes Screws and Nuts)	C-51
54-20012	7-Way US Car Mounting Bracket (Includes Screws and Nuts)	C-51
54-20045	5-Flat Mounting Bracket	C-51
54201-001	LED Amber Sidemarker Lamp w/ Chrome Bezel	K-33
54201-002	LED Red Sidemarker Lamp w/ Chrome Bezel	K-33
54209-001	Round Auxiliary LED Work Light for Hardwiring w/Mounting Stud	K-25
54209-002	Rectangular Auxiliary LED Work Light for Hardwiring w/Mounting Stud	K-25
54209-006	LAMP AG LED	C-45, K-27
54209-008	LAMP AG LED	C-45, K-27
54209-010	LAMP AG LED	C-45, K-27
54209-012	LAMP AG LED	C-45, K-27
54209-017	Round Auxiliary LED Work Light w/19' Coiled Cord & Magnetic Base	K-25
54209-018	Rectangular Auxiliary LED Work Light w/19' Coiled Cord & Magnetic Base	K-25
54209-020	LAMP AG LED 3WY WP BNK RED AMB AMB	C-45, K-27

NUMERICALS

PART NO.	DESCRIPTION	PAGE #
54209-022	LAMP AG LED 4WY WP BNK RED AMB AMB	C-45, K-27
54311-001	4' Plan-O-Gram Incandescent/Electrical	K-61
54311-002	2' Plan-O-Gram LED	K-61
5443	Front Mounted Receiver Accessory, License Plate Holder	A-15
54501-002	7-Way Breaker Box	C-54
54-57-007	7-Way Metal Connector, Trailer End	C-37
54-57-503	7-Way Metal Connector, Car End	C-37
54-60-001	6-Way Die Cast Connector, Car End	C-35
54-60-003	6-Way Die Cast Connector, Trailer End	C-35
54-60-101	6-Way Metal Connector, Car End - USA	C-35
54-60-103	6-Way Metal Connector, Trailer End - USA	C-35
54-6562	7-Way Blade Tester and Trailer Emulator w/LED Display	O-2
54-67-525	7-Way Molded Trailer End Kit w/ 1' Cable (Includes Hardware)	C-39
54700-003	90° Fifth Wheel Adapter Harness, 7-Way Flat Pin Connector Assembly 7 ft., GM, Ford, Dodge, Toyota	C-40/42
54700-004	90° Fifth Wheel Adapter Harness, 7-Way Flat Pin Connector Assembly 7 ft., Toyota	C-40/42
54701-003	90° Fifth Wheel Adapter Harness, 7-Way Flat Pin Connector Assembly 7 ft., GM, Ford, Dodge, Toyota	C-40/42
54701-004	90° Fifth Wheel Adapter Harness, 7-Way Flat Pin Connector Assembly 7 ft., Toyota	C-40/42
54-767811	6-Way Car End Tester w/LED Display	O-2
54-77-001	7-Way Plastic Connector, Car End	C-37
54-77-003	7-Way Plastic Connector, Trailer End	C-37
54-77-071	7-Way Mounting Bracket	C-51
54-77-074	7-Way / 4-Flat Mounting Bracket	C-51
54-77-075	7-Way / 5-Flat Mounting Bracket	C-51
54801-001	Brake Assembly, Right Hand, 10" x 2-1/4"	M-14
54801-002	Brake Assembly, Left Hand, 10" x 2-1/4"	M-14
54801-003	Brake Assembly, Right Hand, 12" x 2"	M-14
54801-004	Brake Assembly, Left Hand, 12" x 2"	M-14
54801-005	Brake Assembly, Right Hand, 10" x 2-1/4", Self-Adjusting	M-14
54801-006	Brake Assembly, Left Hand, 10" x 2-1/4", Self-Adjusting	M-14
54801-007	Brake Assembly, Right Hand, 12" x 2", Self-Adjusting	M-14
54801-008	Brake Assembly, Left Hand, 12" x 2", Self-Adjusting	M-14
5481	7/16" Wire Forms for Fishwiring Bolts in Frames (20 pack)	O-3
5482	1/2" Wire Forms for Fishwiring Bolts in Frames (20 pack)	O-3
54-85-007	Breakaway Switch w/48" Cable and Pin Assembly	M-6
54970	Wt. Dist. Shank, 15,000 lbs. (GTW), 1,500 lbs. (TW), 12" Length & 10,000 lbs. (GTW), 1,000 lbs. (TW), 13" Length	D-17
54976	Titan®, Wt. Dist. Shank, Rating 1,700 lbs. (TW), 2-1/2" Dia., 15" Length, 5-1/4" Rise, 1-1/4" Drop	D-9, D-17
54977	Titan®, Wt. Dist. Shank, Rating 1,700 lbs. (TW), 2-1/2" Dia., 15" Length, 8-1/4" Rise, 5-3/4" Drop	D-9, D-17
54980	Adjustable W/D Ball Mount w/ #54970 Hitch Bar	D-15
54-98-001	Battery Post Adaptor	N-7
54-98-002	Battery Isolator - 3 Terminal	N-7
54-98-003	6 & 7-Way Plug Holder	C-53
54-98-004	Battery Isolator - 4 Terminal	N-7
54-98-050	7-Way Blade to 4-Flat Adapter	C-47
54-98-051	7-Way Blade to 6-Way Round Pin (Auxiliary in Center) Adapter	C-47
54-98-052	7-Way Round Pin to 4-Flat Adapter	C-47
54985	Tall Mini Wt.-Dist. Shank, 1-5/8" x 14", 350 lbs. TW, 3,500 lbs. GTW	D-10, D-17
5500	Activator® II Electronic Brake Control, for 1 to 4 Axle Trailers, Timed Actuated	H-8
55010	5/8" Hitch Pin for 2" Sq. Receivers	B-17
55010-050	5/8" Hitch Pin for 2" Sq. Receivers (50 pack)	B-17
5502	Bearing Sets (Cup & Cone)	M-17
5503	Bearing Sets (Cup & Cone)	M-17
5505	Bearing Sets (Cup & Cone)	M-17
5506	Bearing Sets (Cup & Cone)	M-17
5507	Bearing Sets (Cup & Cone)	M-17
5508	Bearing Sets (Cup & Cone)	M-17
5509	Bearing Sets (Cup & Cone)	M-17
5520	Activator® III Electronic Brake Control, for 1 to 4 Axle Trailers, Timed Actuated	H-8

PART NO.	DESCRIPTION	PAGE #
55393	3/8" Wire Forms for Fishwiring Bolts in Frames (1 piece)	O-3
55515	Clip used w/#06237, #55010, #74149 Hitch Pins	B-17
55515-050	Clip used w/#06237, #55010, #74149 Hitch Pins (50 pack)	B-17
5592	Safety Chain, Class II, 72" Length	M-25
56001	Reese Outboard Fifth Wheel Custom Quick Install Brackets	E-6, E-20/23
56001-53	Reese Outboard Fifth Wheel Custom Quick Install Kit (Includes #56001 & #30153)	E-6, E-20/23
56002	Reese Outboard Fifth Wheel Custom Quick Install Brackets	E-6, E-20/23
56002-53	Reese Outboard Fifth Wheel Custom Quick Install Kit (Includes #56002 & #30153)	E-6, E-20/23
5602	Grease Seal	M-17
5603	Grease Seal	M-17
5604	Grease Seal	M-17
5605	Grease Seal	M-17
5606	Grease Seal	M-17
5607	Grease Seal	M-17
5608	Grease Seal	M-17
5621P01	Service Kit, Cable Keeper, -K/KX1051, K/KX1550, KX1575, K2550	J-62
5651	Grease Cap	M-17
5652	Grease Cap	M-17
5691	Receiver Fabrication Part, 12" Combo Bar w/Forged Collar, 2" Sq. ID, Unpainted	A-16
5692	Receiver Fabrication Part, 18" Combo Bar w/Forged Collar, 2" Sq. ID, Unpainted	A-16
5707	Brake Assembly - Dexter 10" x 2-1/4" L/H	M-13, M-16
5708	Brake Assembly - Dexter 10" x 2-1/4" R/H	M-13, M-16
5711	Brake Assembly - Dexter 12" x 2" L/H	M-13, M-16
5712	Brake Assembly - Dexter 12" x 2" R/H	M-13, M-16
5713-HA	Brake Assembly - Hayes 12" x 2" L/H - Replace in Pairs	M-13, M-16
5714-HA	Brake Assembly - Hayes 12" x 2" R/H - Replace in Pairs	M-13, M-16
5720	Brake Assembly Mounting Bolt - 3/8"	M-14
5721	Brake Assembly Mounting Bolt - 7/16"	M-14
5761	Clevis Ball Mount, 9-3/4" Length, Rating 3,500/350 as Ball Mount, Rating 5,000/350 as Clevis Mount, 3/4" Holes, Black Finish	B-16
5762	Clevis Ball Mount, 9-3/4" Length, Rating 6,000/600 as Ball Mount, Rating 6,000/600 as Clevis Mount, 1" Holes, Black Finish	B-16
5763	Pin for Clevis Mount, 3/4" Diameter	B-16
5764	Pin for Clevis Mount, 1" Diameter	B-16
5774	Spindle Nut Kit	M-19
5775	Spindle Nut Kit	M-19
5780	Trailer Tongue Weight Scale, 2,000 lbs. Capacity	D-18, O-3
5780TEK	Wheel Nut	M-19
5787	Wheel Bolt	M-19
5790	Rim Clamps	M-19
5791	Rim Clamp Bolts	M-19
5792	Rim Clamp Bolts	M-19
5793	Rim Clamp Bolts	M-19
5800200	GearCage™ SP (Straight Pipe) Cargo Carrier w/7" Side Rails, 32" x 48" Platform, 2" Sq. Receiver Mount (Includes Silent Hitch Pin)	I-26
5800300	GearCage™ Cargo Carrier Accessory, Ramp 43" x 30" x 1"	I-26
5800600	GearCage™ Cargo Carrier Accessory, Anti-Skid Tape 12'	I-26
5800700	Replacement Part, D-Rings for GearCage™ Cargo Carrier & The Moover™ Transporter System (4 pack)	I-26
5801200	SportWing™ Aluminum Bike Carrier, 2 Bike, 1-1/4" Sq. Receiver Mount, Includes 2" Sq. Receiver Adapter	I-11
5801600	The Moover™ Transporter System w/7" Side Rails, 32" x 48" Platform, 2" Sq. Receiver Mount (Includes Ramp, Anti-Skid Tape, (4) D-Rings & Silent Hitch Pin)	I-25
5802100	Replacement Part, GearCage™ Cargo Carrier w/7" Side Rails, 32" x 48" Platform Only	I-11, I-26
58023	Fifth Wheel Bracket Kit (2002-2008 Dodge RAM 1500 Pickup, 2003-2010 Dodge RAM 2500/3500 HD Pickup w/o Overload Springs) (10 - Bolt Design)	E-16
5802400	Replacement Part, 52" TT (TwinTube™) 2" Sq. Receiver Mount Assembly (Includes Silent Hitch Pin) for GearSpace™ 34 #59105 & #59106	I-18

NUMERICALS

PART NO.	DESCRIPTION	PAGE #
580400	5/8" Chrome Bent Pin Lock	B-18, L-2
580401	5/8" Chrome Dogbone Lock	B-18, L-2
580402	5/8" SS Dogbone Lock	B-18, L-2
580403	Chrome Coupler Lock	B-18, L-2
580404	5/8" Chrome Dogbone Lock w/ Chrome Coupler Lock	B-18, L-2
580405	LOCK 5/8" HITCH PIN-CLASS III Stainless Steel	B-18, L-2
580406	LOCK 5/8" HITCH PIN COUPLER LOCK COMBO Stainless Steel	B-18, L-2
580407	EASY ACCESS RECEIVER LOCK SLEEVED	B-18, L-2
580408	STAINLESS STEEL COUPLER LOCK	B-18, L-2
580409	EASY ACCESS COUPLER LOCK LONG	B-18, L-2
580410	ADJUSTABLE COUPLER LOCK	B-18, L-2
58058	Fifth Wheel Mounting Rails Only (10 - Bolt Design)	E-16
58060	Replacement Part, Ball Assembly for DT #3400, RS #26660 & PS #83660	D-15/16
58062	Replacement Part, Sway Control Adapter, Ball and Plate Assembly w/Mounting Screws for DT #3400, RS #26660	D-15/16
58070	Receiver Tube Cover, 1-1/4" Sq., Black Nylon, (24 pack)	B-21
58079	The Goose® Gooseneck Hitch (Requires Rails & Installation Kit #30035)	G-6
58093	Fifth Wheel Lock Links (4 pack)	E-15
58099	Replacement Part, 20K Head Assembly Only	E-7
58102	Titan®, Ball Mount Reducer Bushing (2-1/2" to 2")	A-11, B-13
58112	Replacement Part, Adjustable Ball Mount w/Hardware for Heavy-Duty Round Bar	D-8
58113	Replacement Part, 600 lbs. Heavy Duty Round Spring Bar (Qty. 1)	D-8
58114	Replacement Part, 800 lbs. Heavy Duty Round Spring Bar (Qty. 1)	D-8
58115	Replacement Part, 1200 lbs. Heavy Duty Round Spring Bar (Qty. 1)	D-8
58146	Replacement Part, 16K Fifth Wheel Head for #58147	E-9
58147	Replacement Part, 16K Cross Member for #58146	E-9
58162	Replacement Part, Snap Up Bracket Handle	D-18
58166	Fifth Wheel Tube Spacer Kit (2002-2008 Dodge RAM 1500 Pickup, 03-10 Dodge RAM 2500/3500 HD Pickup) (10 - Bolt Design)	E-16
58167	Replacement Part, Titan® Trunnion Weight-Distributing Bolt-Together Head Kit	D-7, D-9
58186	Fifth Wheel Bracket Kit (2003-2011 Dodge RAM 2500/3500 HD Pickup w/Overload Springs) (10 - Bolt Design)	E-16, E-24/27
58187	Replacement Part, 20K Pivot Beam	E-7, E-10
581900	F2 Tire Carrier, Heavy Duty Weld-On (U.S. Pat. D603,780)	M-28
581901	F2 Tire Carrier, Super Duty Weld-On Offset	M-28
581902	F2 Tire Carrier, Heavy Duty Bolt-On (U.S. Pat. D605,102)	M-28
581903	F2 Tire Carrier, Super Duty Bolt-On Offset	M-28
581904	F2 Tire Carrier, Heavy Duty Bolt-On Offset	M-28
581905	F2 Tire Carrier, Heavy Duty Bolt-On (U.S. Pat. D605,102)	M-28
581906	F2 Tire Carrier, Super Duty Bolt-On Offset	M-28
581907	F2 Tire Carrier, Heavy Duty Bolt-On Offset	M-28
58197	Fifth Wheel Spacer Kit (00-06 Toyota Tundra, Includes Qty. 8 Additional 3/16" Spacers) (10 - Bolt Design)	E-16, E-24/27
58207	Replacement Part, Heavy-Duty Round & High-Performance Trunnion Bar Wt.-Dist. Head Shim Kit	D-7/8
58208	Chevrolet Composite Bed Kit for Above the Bed Rail Kit #30035 (10 - Bolt Design) used w>Select Series Fifth Wheels & 25K Above-Bed Gooseneck	E-16, G-6, G-8, G-11
58305	Wt. Dist. Accessory, Chain Hanger, Bolt On	D-18
58306	Wt. Dist. Accessory, Chain Hanger, Clamp On	D-18
58309	Fifth Wheel Spacer Kit (2007-2012 Toyota Tundra, Includes (2) 1/2" x 1-1/4" Spacer, (3) 1/2"-13 x 1-3/4" Carriage Bolt, (3) 1/2"-13 x 3" Carriage Bolt, (2) Bevel Washer) (10 - Bolt Design)	E-16, E-24/27
58314	Replacement Part, Mounting Brackets for Fifth Wheel Rails	E-16
58356	Replacement Part, Reese SC 600 lbs. Spring Bar	D-6
58357	Replacement Part, Reese SC 800 lbs. Spring Bar	D-6
58358	Replacement Part, Reese SC 1200 lbs. Spring Bar	D-6
58359	Replacement Part, Reese SC 1500 lbs. Spring Bar	D-6
58369	Replacement Part, Ultra Frame 1500 lbs. Spring Bar	D-7, D-11
58374	Ultra Frame Accessory, Crossstube End Caps for Weld Together Service Body Truck Receivers (2 pack)	A-6
58381	3-1/2" Hole Saw For Hide-A-Goose	G-11, O-3

PART NO.	DESCRIPTION	PAGE #
58385	Replacement Part, 20K & 22K Fifth Wheel Base Vertical Adjustment Bracket w/Mounting Hardware (Qty. 1)	E-7, E-10
58386	Fifth Wheel Bracket Kit (2009-2012 Dodge Ram 1500 Pickup, Except Models w/Dual Exhaust) (10 - Bolt Design)	E-16, E-24/27
58388	Replacement Part, Super Titan®, 3/4" Hitch Pin and Clip for 3" Sq. Receivers	A-12
58392	Replacement Part, Titan® & Ultra Frame Snap-up Bracket w/Set Screw & Safety Pin	D-18
58393	Pole Tongue Adapter and Fastener Kit	D-18
58394	Replacement Part, Hardware for #5800200, #5801600 & #5802100	I-25/26
58395	Replacement Part, Hardware for #5800300 & #5801600	I-25/26
58400	Replacement Part, Bike Carrier Strap for #1370100, #1370400, #1370500, #5801200	I-11
58401	Replacement Part, Bike Carrier Cradles w/Straps for #1370100, #1370400, #1370500, #5801200	I-11
58405	Fifth Wheel Bracket Kit (2004-2011 Nissan Titan) (10 - Bolt Design)	E-16, E-24/27
58419	Replacement Part, Service Kit Adapter Foot for Signature Series Fifth Wheels & Goosenecks is Required When Used on 2011 Ford Reese Elite™ Series & OEM Rail Kits	G-6
58425	Fifth Wheel Bracket Kit (2005-2012 Ford F-250/F-350 Super Duty & 2008-2011 Ford F-450 Super Duty, Except Cab & Chassis) (4 - Bolt Design)	E-16, E-24/27
58426	Fifth Wheel Bracket Kit (2004-2011 Ford F-150 New Body Style) (4 & 10 - Bolt Design)	E-16, E-24/27
58432	Fifth Wheel Bracket Kit (2002-2008 Dodge RAM 1500 Pickup, Except Mega Cab) (4 - Bolt Design)	E-16
58433	Fifth Wheel Bracket Kit (2009-2012 Dodge RAM 1500 Pickup, Except Models w/Dual Exhaust & Crew Cab) (4 - Bolt Design)	E-16, E-24/27
58444	Replacement Part, Pro Series Complete RB, Weight Distributing Bolt-Together Head Shim Kit	D-13
58458	Replacement Part, Trim Rings (Qty. 4) for GM & Dodge Elite™ Series Rail Kits	E-4
5868P01	Winch Handle, 6"	J-62
59000	ROLA®, MOVE® Rigid Base Small Interior Organizer (25" x 15" x 7")	I-30
59001	ROLA®, MOVE® Rigid Base Large Interior Organizer (38" x 15" x 7")	I-30
59003	ROLA®, Airfoil™ SK Roof Top Ski & Snowboard Carrier (16 cubic ft.)	I-16
59004	ROLA®, Airfoil™ LG Roof Top Luggage Carrier (12 cubic ft.)	I-16
5901TEK	P3® T-Slot Bracket	H-10
5904	P3® T-Slot Metal Bracket	H-10
59100	ROLA®, Platypus® Expandable Roof Top Bag (10 to 15 cubic ft.)	I-27
59102	ROLA®, Expandable Cargo Bag (9-1/2 to 11-1/2 cubic ft.)	I-27
59105	ROLA®, GearSpace™ 34 Cargo Carrier w/TwinTube™, Light Gray (34 cubic ft.) (Includes Silent Hitch Pin)	I-18
59106	ROLA®, GearSpace™ 34 Cargo Carrier w/TwinTube™, Dark Gray (34 cubic ft.) (Includes Silent Hitch Pin)	I-18
59108	ROLA®, Adventure System (Includes Tray w/Lights, Pod & 1-1/4" Assy.)	I-17
59109	ROLA®, Adventure System w/Swing Away (Includes Tray w/Lights, Pod & 2" Swing Away Assy.)	I-17
59110	ROLA®, Adventure System w/Tilt (Includes Tray w/Lights, Pod & 2" Tilt Up Assy.)	I-17
59117	ROLA®, Adventure System License Plate Light Kit for the Cargo Tray	I-17
59150	ROLA®, Pursuit™ Roof Top Fold-Away Luggage Carrier (13-1/2 cubic ft.)	I-15
59200	ROLA®, Flat Strap Cargo Net - 36" x 48"	I-31
59204	ROLA®, Lashing Strap - 1" x 10'	I-37
59400	ROLA®, Bike Carrier, 2 Bike, 2" Sq. Receiver Mount, Folding Dual Arm Rail Rack w/Tilt Function, Integrated Retractable Cable Lock, Anti-Sway	I-10
59401	ROLA®, Bike Carrier, 4 Bike, 2" Sq. Receiver Mount, Folding Dual Arm Rail Rack w/Tilt Function, Integrated Retractable Cable Lock, Anti-Sway	I-10
59403	ROLA®, Bike Carrier, 3 Bike, Triple X w/Tilt Function, 1-1/4" Sq. or 2" Sq. Receiver Mount	I-10
59404	ROLA®, Bike Carrier, 1 Bike, Roof Top Rack w/Fork Style Mount	I-5, I-8
59405	Replacement Part, TX Strap (Qty. 1) for Bike Racks #59400, #59401, #59403	I-10

NUMERICALS

PART NO.	DESCRIPTION	PAGE #
59406	Replacement Part, TX Cradle (Qty. 1) for Bike Racks #59400, #59401, #59403	I-10
59407	Replacement Part, TX Anti-Sway Cradle & Strap (Qty. 1) for Bike Racks #59400, #59401, #59403	I-10
59500	ROLA®, 2" Polypropylene Cargo Carrier, 22" x 56" Platform (2 piece), 2" Sq. Receiver Mount, 400 lbs. Capacity	I-21
59502	ROLA®, Steel Cargo Carrier for 2" Sq. Receivers w/5-1/4" Rail, 23" x 56" Platform (2 piece)	I-20
59504	ROLA®, 2 - Piece Roof Top Vortex Cargo Carrier (48" x 37-1/2" x 4") w/Custom Air Deflector	I-19
59505	ROLA®, Roof Top Vortex Cargo Carrier Extension (18-3/4")	I-19
59506	Replacement Part, ROLA®, Roof Top Vortex Cargo Carrier #59504, Hardware Mounting Kit - (1) U-Bolt, (1) Spacer Block, (2) Knobs, & (1) Top Plate	I-19
59507	ROLA®, Steel Cargo Carrier for 1-1/4" Sq. Receivers w/5-1/4" Rail, 23" x 56" Platform (2 piece)	I-20
59508	ROLA®, NV2 Bike Carrier, 2 Bike, 1-1/4" Sq. or 2" Sq. Receiver Mount w/Flip Shank	I-9
59510	Replacement Part, Latch Kit for #59109, #59110	I-17
59512	Replacement Part, Bike Carrier Arm Tube Caps (Qty. 2) for #59508	I-9
59513	Accessory Shank, 1-1/4" Sq. Receiver Mount w/4-1/4" Rise, Includes Pin & Clip for #59400, #59401, #59403, #59508, #63123	I-9/10, I-13/14
59514	Replacement Part, ROLA® Bike Carrier Cradles (Qty. 4) & Anti-Sway Fingers (Qty. 2) for #59508	I-9
59516	LED Light Kit For Railed Cargo Carrier Part #63152, #63153, #63154, #63155, #59108, #59109, #59110, #59502, #59507, #59550. #38174	I-24
59520	Replacement Part, ROLA®, 2" Steel Cargo Carrier #59502, Hardware Mounting Kit - (8) Bolts 3/8"-16 x1" GR5, (8) Locknuts 3/8"-16 GR5, (4) Bolts 7/16"-14 x 1" GR5 & (4) Locknuts 7/16"-14 GR5	I-20
59550	ROLA®, Stingray Folding Cargo Carrier for 2" Sq. Receivers w/5-1/4" Rail, 23" x 56" Platform (2 piece)	I-20
59560	Replacement Part, ROLA® Expandable Cargo Bag #59102, Strap Kit (6)	I-27
59600	ROLA®, Roof Top Ski & Snowboard Carrier	I-5
59701	Replacement Part, Bolts (4) M6 x 30MM	I-6
59702	Replacement Part, Bolts (4) M6 x 50MM	I-6
59703	Replacement Part, Quarter Turn Plugs (4)	I-6
59707	Roof Rack, Removable Anchor Point Xtreme APX Series	I-39/45
59708	Roof Rack, Removable Mount GTX Series	I-39/45
59709	Roof Rack, Removable Mount GTX Series	I-39/45
59710	Replacement Part, Cage Nuts M6-1 (4)	I-6
59711	Roof Rack, Removable Mount RBU Series, 1400mm	I-4, I-39/45
59712	Roof Rack, Removable Mount GTX Series	I-39/45
5973	Replacement Part, 2-5/16" Ball	G-11
59800	Roof Rack, Removable Mount GTX Series	I-39/45
59801	Roof Rack, Removable Mount RM Series	I-39/45
59802	Roof Rack, Removable Mount RM Series	I-39/45
59803	Roof Rack, Removable Mount RM Series	I-39/45
59804	Roof Rack, Removable Mount RM Series	I-39/45
59805	Roof Rack, Removable Mount RM Series	I-39/45
59806	Roof Rack, Removable Mount RM Series	I-39/45
59807	Roof Rack, Removable Mount RM Series	I-39/45
59808	Roof Rack, Removable Rail Bar RB Series	I-39/45
59809	Roof Rack, Removable Rail Bar RB Series	I-39/45
59811	Roof Rack, Removable Mount RM Series	I-39/45
59812	Roof Rack, Removable Rail Bar RBXL Series	I-39/45
59814	Roof Rack, Removable Mount RM Series	I-39/45
59817	Roof Rack, Removable Rail Bar RBXL Series	I-39/45
59818	Roof Rack, Removable Rail Bar RB Series	I-39/45
59819	Roof Rack, Removable Rail Bar RB Series	I-39/45
59820	Roof Rack, Removable Rail Bar RBXL Series	I-39/45
59821	Roof Rack, Removable Anchor Point Xtreme APX Series	I-39/45
59822	Roof Rack, Removable Anchor Point Extended APE Series	I-39/45
59823	Roof Rack, Removable Rail Bar RBXL Series	I-39/45
59824	Roof Rack, Removable Rail Bar RBXL Series	I-39/45

PART NO.	DESCRIPTION	PAGE #
59826	Roof Rack, Removable Rail Bar Extended RE Series	I-39/45
59827	Roof Rack, Removable Rail Bar RB Series	I-39/45
59828	Roof Rack, Removable Rail Bar RB Series	I-39/45
59829	Roof Rack, Removable Rail Bar RB Series	I-39/45
5983	Replacement Part, Magnetic Cover	G-11
59830	Roof Rack, Removable Anchor Point Xtreme APX Series	I-39/45
59831	Roof Rack, Removable Mount RM Series	I-39/45
59832	Roof Rack, Removable Anchor Point Xtreme APX Series	I-39/45
59833	Roof Rack, Removable Anchor Point Xtreme APX Series	I-39/45
59834	Roof Rack, Removable Anchor Point Extended APE Series	I-39/45
59835	Roof Rack, Removable Mount RM Series	I-39/45
59836	Roof Rack, Removable Rail Bar RB Series	I-39/45
59837	Roof Rack, Removable Rail Bar Extended RE Series	I-39/45
59839	Roof Rack, Removable Mount GTX Series	I-39/45
59842	Roof Rack, Removable Mount GTX Series	I-39/45
59846	Replacement Part, Cross Bar Buffer Strips (Qty.2) Service Kit for Roof Racks	I-6
59847	Replacement Part, L-Handle T-27 Torx Driver (Qty.2) Service Kit for Roof Racks	I-6
59849	Roof Rack, Removable Mount REX Series	I-39/45
59866	Roof Rack, Removable Mount GTX Series	I-39/45
59867	Roof Rack, Removable Mount GTX Series	I-39/45
59868	Roof Rack, Removable Rail Bar RBXL Series	I-39/45
59869	Roof Rack, Removable Rail Bar RBXL Series	I-39/45
59870	Roof Rack, Removable Rail Bar RBXL Series	I-39/45
59871	Roof Rack, Removable Rail Bar RB Series	I-39/45
59875	Roof Rack Accessory, Bike Carrier, 1 Bike, w/Extension	I-5, I-8
59876	Roof Rack Accessory, Universal, Multi-Pivot Water Craft Carrier	I-5
59877	Roof Rack Accessory, Water Craft Carrier Sling	I-5
59878	Roof Rack Accessory, Water & Snow Ski Carrier Clip	I-5
59879	Roof Rack Accessory, Tie Down Attachment	I-5
59884	Roof Rack, Removable Mount GTX Series	I-39/45
59886	Replacement Part, RBXL Series Support Cover Kit (Includes: (2) Locking Covers)	I-6
59887	Replacement Part, GTX Series Support Cover Kit (Includes: (1) Left Hand Cover, (1) Right Hand Cover, (2) Hinges & (2) Dummy Locks)	I-6
59893	Roof Rack, Removable Rail Bar RBXL Series	I-39/45
59896	Roof Rack, Removable Mount GTX Series	I-39/45
59897	Roof Rack, Removable Mount RBU Series, 1100mm	I-4, I-39/45
59898	Roof Rack, Removable Mount RBU Series, 1200mm	I-4, I-39/45
59899	Roof Rack, Removable Mount RBU Series, 1300mm	I-4, I-39/45
59904	ROLA®, 1 - Bike Mounting Adapter Kit for #59502, #59507, #59550, #63152, #63153, #63154, #63155, #38174 Cargo Carriers	I-10
5AB-E13517	Fifth Airborne for Venture CJ13517 Trailer Frames	F-11
5AB-E1621-16K	Fifth Airborne Extended 12" Wide Air Ride, 1-Piece Design	F-11
5AB-E1621-610	Fifth Airborne Extended 12" Wide Air Ride	F-11
5AB-E510-710	Fifth Airborne Extended 12-1/2" Wide Air Ride	F-11
5AB-E510-710K	Fifth Airborne Extended 12-1/2" Wide Air Ride for Keystone Trailer Frames	F-11
5AB-E7920	Fifth Airborne for Leeland 7920 Trailer Frames	F-11
5AB-E810	Fifth Airborne for Youngs Trailer Frames	F-11
5AB-S0719-600	Fifth Airborne for Lippert 719 & Fabex 600 Trailer Frames	F-11
5AB-S13515	Fifth Airborne for Venture CJ13515 Trailer Frames	F-11
5AB-S500-700	Fifth Airborne Standard 12-1/2" Wide Air Ride Pin Box	F-11
5AB-S800	Fifth Airborne for Youngs Trailer Frames	F-11
5AB-T320	Fifth Airborne Tube Style 8" Wide Air Ride	F-11
5AB-T7016	Fifth Airborne for RBW 7016	F-11
5AB-T7234	Fifth Airborne Tube Style 12-1/2" Wide	F-11
5AB-T820	Fifth Airborne Tube Style 8" Wide Air Ride	F-11
5AS02	Fifth Airborne Sidewinder Complete Arm Assembly	F-8
5AS16K	Fifth Airborne Sidewinder Complete Arm Assembly	F-7
600051	Display Stand - Dealer RV Aftermarket	P-4
6002	Gooseneck Plate (Requires Rails & Installation Kit #30035)	G-8

NUMERICALS

PART NO.	DESCRIPTION	PAGE #
60037	Class I & II 1-1/4" Sq. Receiver Cover w/Hidden Hitch Logo, Rubber	B-21
60037-024	Class I & II 1-1/4" Sq. Receiver Cover w/Hidden Hitch Logo, Rubber (24 pack)	B-21
6004	Shoe and Lining Kit - Alko 10" x 2-1/4" - Wheel Set	M-17
6005	Shoe and Lining Kit - Alko 12" x 2" - Wheel Set	M-17
60-10-001	Door Electric, Colonial White	M-31
60-10-002	Door Electric, Original White #2	M-31
60-10-006	Door Electric, Soft White #3	M-31
60-10-062	#3 Lock 1.50" Cam Only - for 60-20 Series	M-32
60-10-064	#5 Thumb Lock .675" Cam - for 60-28 & 60-40 Series	M-31
60-10-065	Clip, for #60-10-063, 064	M-31/32
60-10-066	Door Key, Set of 2 for 60 Series (Prior to 1996)	M-32
60-10-090	#1 Lock 1.25" Cam Only - for 60-10, 60-16, 60-18 & 60-34 Series	M-31/32/33
60-10-091	#2 Lock .675" Cam Only- for 60-14, 60-30, 60-32 & 60-36 Series	M-31, M-33
60-10-092	Clip for #60-10-090, 091 & 094	M-31/32/33
60-10-093	Key, CH 751 (Set of 2) for #60-10-090, 091, 094	M-31/32/33
6011	Fifth Wheel 10" Lube Plate	E-15
60-14-002	Door Electric 30 Amp, Original White #2	M-31
60-14-006	Door Electric 30 Amp, Soft White #3	M-31
60-16-001	Door Gas Fill, Colonial White	M-32
60-16-002	Door Gas Fill, Original White #2	M-32
60-16-006	Door Gas Fill, Soft White #3	M-32
60-18-001	Door Gas Fill, Colonial White	M-32
60-18-002	Door Gas Fill, Original White #2	M-32
60-20-001	Door Gas Fill, Colonial White	M-32
60-20-002	Door Gas Fill, Original White #2	M-32
6021	22K Fifth Wheel Hitch Assembly & 90° Fifth Wheel Adapter Harness #50-97-410 (Requires Rails & Installation Kit #30035 or #30095)	E-10
6026	Replacement Part, 20K Fifth Wheel Head Assembly w/Pivot Beam	E-10
60-28-002	Door Lift System 5.5" x 5.5" Original White #2	M-31
60-30-001	Door Water Fill Gravity, 5-1/2" x 5-1/2", Colonial White	M-33
60-30-002	Door Water Fill Gravity, 5-1/2" x 5-1/2", Original White #2	M-33
60-30-006	Door Water Fill Gravity, 5-1/2" x 5-1/2", Soft White #3	M-33
6032	16K Fifth Wheel Hitch Assy. (Requires Rails & Installation Kit #30035)	E-10
60-32-006	Door City Water Fill, 5-1/2" x 5-1/2", Soft White #3	M-33
6033	16K Fifth Wheel w/Slider Unit (Requires Rails & Installation Kit #30035)	E-10
60-34-001	Door Water Fill Combined City/Gravity Colonial White	M-33
60-34-002	Door Water Fill Combined City/Gravity Original White #2	M-33
60-34-006	Door Water Fill Combined City/Gravity Soft White #3	M-33
6042	Replacement Part, 16K Head Assembly	E-10
6044	Replacement Part, Fifth Wheel Leg (Qty. 1)	E-10
60-44-701	Low Pressure Water Cap & Strap	M-33
60-50-001	Mounting Bracket (MB 1200)	K-54
61009	1200 lbs. Heavy Duty Round Bar WD Hitch w/54970 Shank	D-8
6106	Magnet Kit - Alko 10" x 2-1/4"	M-15/16
6109	Magnet Kit - Alko 12" x 2", 6 & 7K	M-15/16
61300	Sidewinder Turret w/Hardware	F-9/10
61301	Spacer Kit for Sidewinder Turret When Replacing 12-1/2" Pin Box	F-9/10
61302	Sidewinder Turret w/Hardware	F-10
61410	Sidewinder Combo, 16K Arm w/King Pin #SW16K, Turret w/Hardware #61300 & Spacer Kit #61301	F-10
61411	Sidewinder Combo, 19K Arm w/King Pin #SW19K, Turret w/Hardware #61300 & Spacer Kit #61301	F-9
61412	Elite™ Series Airborne Sidewinder Combo, 16K Arm w/King Pin #5AS16K, Turret w/Hardware #61300 & Spacer Kit #61301	F-7
61413	Airborne Sidewinder Combo, 19-1/2K Arm w/King Pin #5AS02, Turret w/Hardware #61300 & Spacer Kit #61301	F-8
61420	Sidewinder Combo, 16K Arm w/King Pin #SW16K, Turret w/Hardware #61300	F-10
61421	Sidewinder Combo, 19K Arm w/King Pin #SW19K, Turret w/Hardware #61300	F-9

PART NO.	DESCRIPTION	PAGE #
61422	Elite™ Series Airborne Sidewinder Combo, 16K Arm w/King Pin #5AS16K, Turret w/Hardware #61300	F-7
61423	Airborne Sidewinder Combo, 19-1/2K Arm w/King Pin #5AS02, Turret w/Hardware #61300	F-8
6145	Bike Carrier Y-Frame Adapter	I-14
61450	Sidewinder Combo, 16K Arm w/King Pin #SW16K & Turret w/Hardware #61302	F-10
61452	Elite™ Series Airborne Sidewinder Combo, 16K Arm w/King Pin #5AS16K & Turret w/Hardware #61302	F-7
62	6-Way Metal Connector, Car End	C-35
6201	Clevis Ball Mount, 8-7/8" Length, Rating 6,000/600 as Ball Mount, 10,000/1000 as Clevis Mount, 1" Holes, Solid Shank, Black Finish	B-16
6205	Actuating Lever - Alko 10" x 2-1/4" R/H	M-16
6206	Actuating Lever - Alko 10" x 2-1/4" L/H	M-16
6211	Actuating Lever - Alko 12" x 2" R/H	M-16
62112	Replacement Part, Heavy-Duty Round Bar Wt. Dist. Bolt-Together Hitch Head Assembly and Fasteners	D-12
62113	Replacement Part, Heavy-Duty Round Bar/600 lbs. Spring Bar (Qty. 1)	D-12
62114	Replacement Part, Heavy-Duty Round Bar/800 lbs. Spring Bar (Qty. 1)	D-12
62115	Replacement Part, Heavy-Duty Round Bar/1200 lbs. Spring Bar (Qty. 1)	D-12
6212	Actuating Lever - Alko 12" x 2" L/H	M-16
62167	Replacement Part, Heavy-Duty Trunnion Weight-Distributing Bolt-Together Head Kit	D-11
63	6-Way Metal Connector, Trailer End	C-35
6300	Remov-A-Ball™ Gooseneck Hitch w/2-5/16" Ball, Rating 30,000 lbs.	G-8, G-13/15
630044	Remov-A-Ball® Gooseneck Hitch w/2-5/16" Ball, Rating 30,000 lbs.	G-10, G-16/18
63010	Pintle Hook w/1-7/8" Ball (Inc. Grade 8 Hardware) Hook Rating 16,000 lbs. (GTW), Ball Rating 6,000 lbs. (GTW), 3,000 lbs. (VL), Black	B-15
63011	Pintle Hook w/2" Ball (Inc. Grade 8 Hardware) Hook Rating 16,000 lbs. (GTW), Ball Rating 10,000 lbs. (GTW), 3,000 lbs. (VL), Black	B-15
63012	Pintle Hook w/2-5/16" Ball (Inc. Grade 8 Hardware) Hook Rating 16,000 lbs. (GTW), Ball Rating 14,000 lbs. (GTW), 3,000 lbs. (VL), Black	B-15
63013	5 Ton Regular Pintle Hook (Inc. Grade 8 Hardware) Rating 10,000 lbs. (GTW), 2,000 lbs. (VL), Black	B-15
63014	10 Ton Regular Pintle Hook (Inc. Grade 8 Hardware) Rating 20,000 lbs. (GTW), 4,000 lbs. (VL), Black	B-15
63015	15 Ton Regular Pintle Hook (Inc. Grade 8 Hardware) Rating 30,000 lbs. (GTW), 6,000 lbs. (VL), Black	B-15
63016	30 Ton Regular Pintle Hook (Hardware Included) Rating 60,000 lbs. (GTW), 14,000 lbs. (VL), Black	B-15
63017	Pintle Hook Replacement Ball, 1-7/8" x 1-1/4" Dia. Shank, 6,000 lbs. Maximum VL, Chrome	B-15
63018	Pintle Hook Replacement Ball, 2" x 1-1/4" Dia. Shank, 10,000 lbs. Maximum VL, Chrome	B-15
63019	Pintle Hook Replacement Ball, 2-5/16" x 1-1/4" Dia. Shank, 14,000 lbs. Maximum VL, Chrome	B-15
63020	Replacement Part, Pin & Chain Assy. for Pintle Hooks, 1/4" Dia. for Pintle Hooks	B-15
63022	Lunette Ring, 2-1/2" Diameter, w/1-1/2" Shank 15,000 lbs. Capacity	B-16
63023	4 Bolt Flange Lunette Ring, 2-1/2" Diameter, 42,000 lbs. Capacity	B-16
63024	Forged D-Ring w/Mounting Bracket, 1/2", 12,000 lbs., Yellow Zinc	M-26
63025	Forged D-Ring w/Weld On Mounting Bracket, 5/8" Dia. x 3/8" Thick c1045 Material, 18,000 lbs.	M-26
63026	Forged D-Ring w/Weld On Mounting Bracket, 3/4" Dia. x 3/8" Thick c1045 Material, 26,500 lbs.	M-26
63027	Forged D-Ring w/Weld On Mounting Bracket, 1" Dia. x 3/8" Thick c1045 Material, 46,760 lbs.	M-26
63028	Forged D-Ring w/Weld On Mounting Bracket, 5/8" Dia., 1" x 5" x 6" c1045 Material, 46,760 lbs.	M-26
63029	Tow Hook, Chrome 10,000 lbs.	M-26
6302P01	Winch Handle, 8"	J-62

NUMERICALS

PART NO.	DESCRIPTION	PAGE #
6303	Replacement Part, 3" Ball (2-5/16" use #5973)	G-11
63030	Tow Hook, Black 10,000 lbs.	M-26
63032	Pintle Hook Mounting Hardware Kit	B-15
63033	Replacement Part, Mounting Hardware Kit for 4 Bolt Flange Lunette Ring #63023	B-16
63034	Safety Chain, Class I GWR 2,000 lbs. 72", S-Hooks, Both Ends (1 piece)	M-25
63036	Adjustable Lunette Ring with Channel, 3" Dia., 24,000 lbs. Capacity	B-16
63035	Safety Chain, Class III GWR 5,000 lbs. 72", Quick Links, Both Ends (1 piece)	M-25
63040	Receiver Mount Pintle Hook w/1-7/8" Ball (Inc. Grade 8 Hardware) Hook Rating 12,000 lbs. (GTW), Ball Rating 2,000 lbs. (GTW), 2,400 lbs. (VL), Black	B-16
63041	Receiver Mount Pintle Hook w/2" Ball (Inc. Grade 8 Hardware) Hook Rating 12,000 lbs. (GTW), Ball Rating 7,000 lbs. (GTW), 2,400 lbs. (VL), Black	B-16
63042	Receiver Mount Pintle Hook w/2-5/16" Ball (Inc. Grade 8 Hardware) Hook Rating 12,000 lbs. (GTW), Ball Rating 12,000 lbs. (GTW), 2,400 lbs. (VL), Black	B-16
63043	5 Ton Receiver Mount Pintle Hook, Solid Shank, Rating 10,000 lbs. (GTW), 2,000 lbs. (VL), Black	B-16
63044	Receiver Mount Tow Hook, Solid Shank, GWR 10,000 lbs. 7-3/4" Length	B-16
63045	Receiver Mount Tow Eyelet, Solid Shank, GWR 10,000 lbs. 7-3/8" Length	B-16
63046	Receiver Mount Tow Ring, Solid Shank, GWR 8,000 lbs. 7-3/8" Length	B-16
63047	Receiver Mount Tow Hook, Hollow Shank, GWR 8,000 lbs. 7" Length	B-16
63050	Pintle Hook Replacement Ball, 1-7/8" x 1-1/8" Dia. Shank, 6,000 lbs. Maximum VL, Chrome	B-15
63051	Pintle Hook Replacement Ball, 2" x 1-1/8" Dia. Shank, 10,000 lbs. Maximum VL, Chrome	B-15
63052	Pintle Hook Replacement Ball, 2-5/16" x 1-1/8" Dia. Shank, 14,000 lbs. Maximum VL, Chrome	B-15
63056	Pintle Hook Receiver Mount, Hollow Shank, 7-5/8" Length, 6,000 lbs. (GTW), 600 lbs. (TW), Black	B-15
63057	Pintle Hook Receiver Mount, Solid Shank, 7-5/8" Length, 12,000 lbs. (GTW), 1,200 lbs. (TW), Black	B-15
63058	Pintle Hook Receiver Mount, Solid Shank, Deep Drop, 11-3/8" Length x 12-1/2" Drop, 8,000 lbs. (GTW), 800 lbs. (TW), Black	B-15
63059	Pintle Hook Receiver Mount, Solid Shank, 11-3/8" Length, 12,000 lbs. (GTW), 1,200 lbs. (TW), Black	B-15
63060	Adjustable Lunette Ring with Hardware, 3" Dia., 24,000 lbs. Capacity (Adjustable Channel Sold Separately)	B-16
6308	Replacement Part, U-Bolt Safety Chain Kit	G-11
63120	Bike Carrier, 2 Bike, 1-1/4" Sq. Receiver Mount w/Tilt Function	I-13
63123	Bike Carrier, 3 Bike, 1-1/4" Sq. or 2" Sq. Receiver Mount w/ Tilt Function	I-13
63124	Bike Carrier, 4 Bike, w/Tilt Function, 2" Sq. Receiver Mount	I-13
63125	Bike Carrier, 4 Bike, Towable w/Tilt Function, 2" Sq. Receiver Mount	I-13
6312P01	Winch Handle, 7"	J-62
63130	Bike Carrier, 1 Bike, Roof Top Rack Mount	I-5, I-8
63132	Bike Carrier, 2 Bike, Fixed Position, Universal Mount	I-13
63134	Bike Carrier, 2 Bike, Rail Rack, 1-1/4" Sq. Receiver Mount, Includes 2" Sq. Receiver Adapter	I-12
63135	Replacement Part, Hook & Loop Strap (Qty.4) for Bike Racks #63134	I-12
63144	Bike Carrier, 4 Bike, 1-1/4" Sq. Receiver Mount w/Tilt Function, Includes 2" Sq. Receiver Adapter	I-12
63145-025	Silent Hitch Pin w/Clip, 5/8" for 2" Sq. Receivers (25 pack)	B-19, L-3
63146	Silent Hitch Pin w/Handle & Clip, 5/8" for 2" Sq. Receivers	B-19, L-3
63148	Replacement Part, Bike Carrier Cradle for #63120, #63123, #63124	I-13
63150	Bullet Box™ Roof Top Luggage Carrier (13 cubic ft.)	I-16
63152	Cargo Carrier w/5-1/2" Side Rails, 24" x 60" Platform, 2" Sq. Receiver Mount	I-22
63153	Cargo Carrier w/5-1/2" Side Rails, 24" x 60" Platform, 2" Sq. Receiver Mount, Bolt Together	I-22

PART NO.	DESCRIPTION	PAGE #
63154	Cargo Carrier w/5-1/2" Side Rails, 20" x 48" Platform, 11" x 1-1/4" Sq. Receiver Mount	I-22
63155	Cargo Carrier w/5-1/2" Side Rails, 20" x 48" Platform, 11" x 1-1/4" Sq. Receiver Mount, Bolt Together	I-22
63160	Replacement Part, Cargo Carrier #63152, #63153, #63154, #63155, Hardware Mounting Kit (3-Bolts M12 x 1.75" x 80mm CL9.8, 3-Locknuts M12 x 1.75", 8-Bolts M8 x 1.25" x 20mm CL9.8, 8-Locknuts M8 x 1.25", 8-Flat Washers 8mm)	I-22
63180	Adjustable Tow Bar, 5,000 lbs. GVW Capacity	N-4
63181	Adjustable Tow Bar w/Bolt Together 2-Piece Adjustment Arms, 5,000 lbs. GVW Capacity	N-4
63201	J-Pin® Anti-Rattle Pin & Barrel Lockset for 2" Sq. Receivers	B-17
63202	1/2" Integral Pin & Clip for 1-1/4" Sq. Receivers - Stainless	B-17
63203	5/8" Integral Pin & Clip for 2" Sq. Receivers - Stainless	B-17
63204	1/2" Integral Pin & Clip for 1-1/4" Sq. Receivers - Zinc	B-17
63205	5/8" Integral Pin & Clip for 2" Sq. Receivers - Zinc	B-17
63216KA	Receiver Lock, Dead Bolt, 1/2" for 1-1/4" Sq. Receivers, Black Finish (Keyed Alike Bulk)	B-20, L-4
63217KA	Receiver Lock, Dead Bolt, 5/8" for 2" Sq. Receivers, Black Finish (Keyed Alike Bulk)	B-20, L-4
63218KA	Combo Lock Set, 1/2" Dead Bolt for 1-1/4" Sq. Receiver and Trailer Coupler 1/2" Span, Black Finish (Keyed Alike Bulk)	B-20, L-4
63219KA	Combo Lock Set, 5/8" Dead Bolt for 2" Sq. Receiver and Trailer Coupler 1/2" Span, Black Finish (Keyed Alike Bulk)	B-20, L-4
63220KA	Coupler Lock, Dead Bolt, 1/2" Span, Black Finish (Keyed Alike Bulk)	B-20, L-4
63221KA	Coupler Lock, Dead Bolt, 2" Span, Black Finish (Keyed Alike Bulk)	B-20, L-4
63222KA	Coupler Lock, Dead Bolt Surge Brake, 2-3/8" Span, Black Finish (Keyed Alike Bulk)	B-20, L-4
63223	Receiver Lock, Bent Pin, 5/8" for 2" & 2-1/2" Sq. Receivers	B-19, L-3
63224	Receiver Lock, Bent Pin, 1/2" for 1-1/4" Sq. Receivers & Fifth Wheel Base Rails	B-19, L-3
63225	Coupler Lock	B-19, L-3
63226	Coupler Lock, Universal	B-19, L-3
63227	Coupler Lock, "Gorilla Guard" for 2-5/16" Couplers	B-19, L-3
63228	Coupler Lock, "Gorilla Guard" for 2" Couplers	B-19, L-3
63230	Coupler Lock, Adjustable Brass	B-19, L-3
63232	Receiver Lock, Silent Hitch Pin w/Lock & Wrench, 5/8" for 2" Sq. Receivers	B-19, L-3
63232-025	Receiver Lock, Silent Hitch Pin w/Lock & Wrench, 5/8" for 2" Sq. Receivers (25 pack)	B-19, L-3
63233	Cable Lock, 5/16" x 10' Length	L-6
63234	Receiver Lock, for 1-1/4", 2" & 2-1/2" Sq. Receivers w/Universal Stainless Steel Sleeve	B-19, L-3
63235	Trailer Guardian Single Arm Lock for 2-1/2" Width Ball Mount Platform w/1" Ball Hole	B-20, L-4
63236	Trailer Guardian Dual Arm Lock for 2-1/2" Width Ball Mount Platform w/1" Ball Hole	B-20, L-4
63237	Trailer Guardian Single Arm Lock for 3" Width Ball Mount Platform w/1" Ball Hole	B-20, L-4
63238	Trailer Guardian Dual Arm Lock for 3" Width Ball Mount Platform w/1" Ball Hole	B-20, L-4
63240	Packaged 5/8" Grooved Style Hitch Pin and Clip for 2" Sq. Receivers	B-17
63240-050	Bulk 5/8" Grooved Style Hitch Pin and Clip for 2" Sq. Receivers (50 pack)	B-17
63241	Packaged 1/2" Grooved Style Hitch Pin and Clip for 1-1/4" Sq. Receivers	B-17
63241-050	Bulk 1/2" Grooved Style Hitch Pin and Clip for 1-1/4" Sq. Receivers (50 pack)	B-17
63242	Packaged 5/8" Hole Style Hitch Pin and Clip for 2" Sq. Receivers	B-17
63242-050	Bulk 5/8" Hole Style Hitch Pin and Clip for 2" Sq. Receivers (50 pack)	B-17
63242-100	Bulk 5/8" Hole Style Hitch Pin and Clip for 2" Sq. Receivers (100 pack)	B-17
63242-500	Bulk 5/8" Hole Style Hitch Pin and Clip for 2" Sq. Receivers (500 pack)	B-17
63243	Packaged 5/8" Grooved Style Hitch Pin and Clip for Titan® 2-1/2" Sq. Receivers	B-17
63248	Receiver Lock, Barrel Style w/Bent Pins, 1/2" for 1-1/4" Sq. Receivers & 5/8" for 2" Sq. Receivers	B-19, L-3

NUMERICALS

PART NO.	DESCRIPTION	PAGE #
63249	Combo Lock Set, Barrel Style w/Bent Pins, 1/2" for 1-1/4" Sq. Receivers, 5/8" for 2" Sq. Receivers & Adjustable Brass Coupler Lock	B-19, L-3
63250	Combo Lock Set, Dogbone Style, 1/2" for 1-1/4" Sq. Receivers, 5/8" for 2" Sq. Receivers w/Universal Stainless Steel Sleeve & Coupler Lock	B-19, L-3
63251	Fifth Wheel King Pin Lock	E-15, L-4
63252	Receiver Lock, Dogbone Style, 5/8" for 2-1/2" Sq. Receivers, 3-1/2" Span	B-19, L-3
63253	Receiver Lock, Barrel Style w/Bent Pin, 5/8" for 2-1/2" Sq. Receivers, 3-1/2" Span	B-19, L-3
63254	Receiver Lock, Barrel Style w/Bent Pin, 1/2" for Fifth Wheel Base Rails	E-15, L-4
63300	Solo Hitch Alignment System	B-7, M-23
63450	Trailer Accessory, Tire Chock & Tongue Jack Caster Wheel Dock Combo	M-24
6352	Gooseneck Ball Storage Pouch for Remov-A-Ball®	B-11, G-11
63801	Interchangeable Hitch Ball, 3/4" Shank, 1-7/8" & 2" Balls, 5,000 lbs. Rating	B-3
63802	Interchangeable Hitch Ball, 1" Shank, 1-7/8" & 2" Balls, 8,000 lbs. Rating	B-3
63803	Interchangeable Hitch Ball, 1" Shank, 1-7/8", 2", & 2-5/16" Balls, 8,000 lbs. Rating	B-3
63804	Interchangeable Hitch Ball, 1" Shank, 2" & 2-5/16" Balls, 8,000 lbs. Rating	B-3
63805	Interchangeable Hitch Ball, 1-7/8" Replacement Ball for 3/4" & 1" Shanks	B-3
63806	Interchangeable Hitch Ball, 2" Replacement Ball for 3/4" & 1" Shanks	B-3
63807	Interchangeable Hitch Ball, 2-5/16" Replacement Ball for 1" Shank	B-3
63808	Interchangeable Hitch Ball, 3/4" Replacement Shank	B-3
63809	Interchangeable Hitch Ball, 1" Replacement Shank	B-3
63810	Hitch Ball, 1-7/8" x 3/4" x 1-1/2", 2,000 lbs. GTW Chrome	B-4
63810-006	Hitch Ball, 1-7/8" x 3/4" x 1-1/2", 2,000 lbs. GTW Chrome (6 pack)	B-4
63811	Hitch Ball, 1-7/8" x 3/4" x 1-1/2", 2,000 lbs. GTW Zinc	B-4
63812	Hitch Ball, 1-7/8" x 3/4" x 2-3/8", 2,000 lbs. GTW Chrome	B-4
63813	Hitch Ball, 1-7/8" x 3/4" x 2-3/8", 2,000 lbs. GTW Zinc	B-4
63814	Hitch Ball, 1-7/8" x 3/4" x 3-3/8", 2,000 lbs. GTW Chrome	B-4
63816	Hitch Ball, 1-7/8" x 1" x 2-1/8", 2,000 lbs. GTW Chrome	B-4
63816-006	Hitch Ball, 1-7/8" x 1" x 2-1/8", 2,000 lbs. GTW Chrome (6 pack)	B-4
63817	Hitch Ball, 1-7/8" x 1" x 2-1/8", 2,000 lbs. GTW Zinc	B-4
63818	Hitch Ball, 1-7/8" x 1" x 3-3/8", 2,000 lbs. GTW Chrome	B-4
63819	Hitch Ball, 1-7/8" x 1" x 3-3/8", 2,000 lbs. GTW Zinc	B-4
63820	Hitch Ball, 2" x 3/4" x 1-1/2", 3,500 lbs. GTW Chrome	B-4
63821	Hitch Ball, 2" x 3/4" x 1-1/2", 3,500 lbs. GTW Zinc	B-4
63822	Hitch Ball, 2" x 3/4" x 2-3/8", 3,500 lbs. GTW Chrome	B-4
63823	Hitch Ball, 2" x 3/4" x 2-3/8", 3,500 lbs. GTW Zinc	B-4
63824	Hitch Ball, 2" x 3/4" x 3-3/8", 3,500 lbs. GTW Chrome	B-4
63826	Hitch Ball, 2" x 1" x 2-1/8", 6,000 lbs. GTW Chrome	B-4
63826-006	Hitch Ball, 2" x 1" x 2-1/8", 6,000 lbs. GTW Chrome (6 pack)	B-4
63827	Hitch Ball, 2" x 1" x 2-1/8", 6,000 lbs. GTW Zinc	B-4
63828	Hitch Ball, 2" x 1" x 3-3/8", 6,000 lbs. GTW Chrome	B-4
63829	Hitch Ball, 2" x 1" x 3-3/8", 6,000 lbs. GTW Zinc	B-4
63830	Hitch Ball, 2" x 1-1/4" x 2-3/4", 8,000 lbs. GTW Chrome	B-4
63831	Hitch Ball, 2" x 1-1/4" x 2-3/4", 8,000 lbs. GTW Zinc	B-4
63832	Hitch Ball, 2-5/16" x 1" x 2-1/8", 6,000 lbs. GTW Chrome	B-4
63832-006	Hitch Ball, 2-5/16" x 1" x 2-1/8", 6,000 lbs. GTW Chrome (6 pack)	B-4
63833	Hitch Ball, 2-5/16" x 1" x 2-1/8", 6,000 lbs. GTW Zinc	B-4
63834	Hitch Ball, 2-5/16" x 1-1/4" x 2-3/4", 12,000 lbs. GTW Chrome	A-5, B-4
63835	Hitch Ball, 2-5/16" x 1-1/4" x 2-3/4", 12,000 lbs. GTW Zinc	A-5, B-4
63836	Hitch Ball, 2-5/16" x 1-1/4" x 2-3/4", 14,000 lbs. GTW Chrome	A-5, A-11, B-4
63840	Hitch Ball, 2-5/16" x 1-1/4" x 2-3/4", 20,000 lbs. GTW Chrome	A-5, A-11, B-4
63851	Packaged Hitch Ball, 1-7/8" x 1" x 2-1/8", 2,000 lbs. GTW Stainless Steel	B-4

PART NO.	DESCRIPTION	PAGE #
63852	Packaged Hitch Ball, 2" x 1" x 2-1/8", 6,000 lbs. GTW Stainless Steel	B-4
63853	Packaged Hitch Ball, 2-5/16" x 1" x 2-1/8", 6,000 lbs. GTW Stainless Steel	B-4
63880	Packaged Hitch Ball, 1-7/8" x 3/4" x 1-1/2", 2,000 lbs. GTW Chrome	B-4
63881	Packaged Hitch Ball, 1-7/8" x 3/4" x 1-1/2", 2,000 lbs. GTW Zinc	B-4
63882	Packaged Hitch Ball, 1-7/8" x 3/4" x 2-3/8", 2,000 lbs. GTW Chrome	B-4
63884	Packaged Hitch Ball, 1-7/8" x 1" x 2-1/8", 2,000 lbs. GTW Chrome	B-4
63885	Packaged Hitch Ball, 1-7/8" x 1" x 2-1/8", 2,000 lbs. GTW Zinc	B-4
63887	Packaged Hitch Ball, 2" x 3/4" x 1-1/2", 3,500 lbs. GTW Chrome	B-4
63888	Packaged Hitch Ball, 2" x 3/4" x 1-1/2", 3,500 lbs. GTW Zinc	B-4
63889	Packaged Hitch Ball, 2" x 3/4" x 2-3/8", 3,500 lbs. GTW Chrome	B-4
63891	Packaged Hitch Ball, 2" x 1" x 2-1/8", 6,000 lbs. GTW Chrome	B-4
63892	Packaged Hitch Ball, 2" x 1" x 2-1/8", 6,000 lbs. GTW Zinc	B-4
63894	Packaged Hitch Ball, 2-5/16" x 1" x 2-1/8", 6,000 lbs. GTW Chrome	B-4
63895	Packaged Hitch Ball, 2-5/16" x 1" x 2-1/8", 6,000 lbs. GTW Zinc	B-4
63896	Packaged Hitch Ball, 2-5/16" x 1-1/4" x 2-3/4", 12,000 lbs. GTW Chrome	B-4
63897	Packaged Hitch Ball, 2-5/16" x 1-1/4" x 2-3/4", 12,000 lbs. GTW Zinc	B-4
63899	Packaged Hitch Ball, 2" x 1-1/4" x 2-3/4", 8,000 lbs. GTW Chrome	B-4
63970	Wt. Dist. Shank, 15,000 lbs. (GTW), 1,500 lbs. (TW), 12" Length & 10,000 lbs. (GTW), 1,000 lbs. (TW), 13" Length	D-17
63971	Wt. Dist. Shank, 15,000 lbs. (GTW), 1,500 lbs. (TW), 14" Length, Extra Drop (Use in Drop Position Only)	D-17
64 0801	Kit-44305R Coupler Replacement	J-48
64-10-064	Thumb Lock .675" Cam & Clip - for #60-28 & #60-40 Series	M-31
64-10-090	Lock 1.25" Cam, Clip & Key - for 60-10, 60-16, 60-18 & 60-34 Series	M-31/32/33
64-10-091	Lock .675" Cam, Clip & Key - for 60-14, 60-28, 60-30, 60-32 & 60-36 Series	M-31, M-33
64-10-093	Key, CH 751 (Set of 2) for #60-10-090, 094	M-31/32/33
6425	Template for #8339 Folding Gooseneck Installation, Stainless Steel	G-11
6431	Receiver Tube Cover, 2" Sq., Chevrolet Logo	B-22
6432	Receiver Tube Cover, 2" Sq., Dodge Ram Logo	B-22
6433	Receiver Tube Cover, 2" Sq., Ford Logo	B-22
64-44-701	Low Pressure Water Cap & Strap	M-33
64-50-001	Support Mounting Bracket	K-54
6495	Front Mount Receiver Accessory, Winch Mounting Plate	A-15
6500	Cargo Carrier for 1-1/4" Sq. Receivers, 20" x 48" Platform	I-23
6501	Cargo Carrier for 2" Sq. Receivers, 20" x 60" Platform	I-23
6502	Folding Cargo Carrier for 2" Sq. Receivers, 20" x 48" Platform	I-23
6504	Tail Light 8-Function, Waterproof Over 80" Low Profile w/ Stripped Leads - Left/Roadside	I-24
6505	Bike Rack Adapter for #6500, #6501 Cargo Carrier	I-14, I-24
6550	Replacement Part, Cargo Carrier #6500/#6501, Hardware Mounting Kit (2-Carriage Bolts 3/8"-16 x 3" GR5, 2-Locknuts 3/8"-16, 2-Reflectors, 1-Dashboard Reminder Card, 1-Clip)	I-23
65509	600 lbs. Heavy Duty Round Bar WD Hitch w/#54970 Shank	D-8
6555	Replacement Part, Cargo Carrier #6502, Hardware Mounting Kit (2-Bolts 1/2"-13 x 3" GR8, 2-Locknuts 1/2"-13, 1-Lock Pin, 1-Spacer Tube, 2-Reflectors, 1-Dashboard Reminder Card, 1-Clip)	I-23
6562	7-Way Blade Tester and Trailer Emulator w/LED Display	O-2
6565	Tekonsha Current Monitor	O-2
6580	Adjustable Ball Mount, 12" Length, 6,000 lbs. (GTW), 600 lbs. (TW)	B-11
65852	Cargo Carrier for 2" Sq. Receivers, 20" x 36" Platform	I-24
65855	Cargo Carrier for 1-1/4" Sq. Receivers, 20" x 36" Platform	I-24
65856	Rail Kit for #65852 & #65855 Cargo Carriers	I-24
65857	Replacement Part, Mounting Hardware for #65852 & #65855 Cargo Carrier	I-24
65860	Cargo Carrier Bag - 35" x 19" x 12"	I-28

NUMERICALS

PART NO.	DESCRIPTION	PAGE #
65861	Camo Cargo Carrier Bag - 35" x 19" x 12"	I-28
66 0801	Kit-WEDGLTCH 2" Repair-43805w/A200C	J-39
66006	Titan®, Trunnion Bar Bolt-Together Wt. Dist. Kit, 17,000 lbs. (GTW), 1,700 lbs. (TW)	A-11, D-9
66009	Replacement Part, 1200 lbs. High-Performance Spring Bar & Trunnion (Qty. 1)	D-7
66020	600 lbs. Adj. High-Performance Trunnion Style (No Shank)	D-7
66021	800 lbs. Adj. High-Performance Trunnion Style (No Shank)	D-7
66022	1200 lbs. Adj. High-Performance Trunnion Style w/o Shank	D-7
66024	350 Mini Weight Distributing Kit w/2" Hitch Ball	D-10
6604	Grease Seal	M-17
66041	350 Mini Weight Distributing Kit w/2" Hitch Ball for Fleetwood/Coleman Trailers	D-10
6605	Grease Seal	M-17
66065	600 lbs. Heavy Duty Round Bar WD Hitch (No Shank)	D-8
66066	800 lbs. Heavy Duty Round Bar WD Hitch (No Shank)	D-8
66067	1200 lbs. Heavy Duty Round Bar WD Hitch w/o Shank	D-8
66069	Light-Duty Weight Distributing Kit (Single Bar) for A-Frame Trailers	D-10
66071	Light-Duty Weight Distributing Kit (Single Bar) for Pole Tongue Trailers	D-10
66072	Strait-Line™ 600 lbs. Trunnion Bar (includes #66020 & #26002)	D-5
66073	Strait-Line™ 800 lbs. Trunnion Bar (includes #66021 & #26002)	D-5
66074	Strait-Line™ 1200 lbs. Trunnion Bar (includes #66022 & #26002)	D-5
66075	Strait-Line™ 1700 lbs. Trunnion Bar (includes #66006 & #26002)	D-5
66076	Strait-Line™ 600 lbs. Round Bar (includes #66065 & #26002)	D-5
66077	Strait-Line™ 800 lbs. Round Bar (includes #66066 & #26002)	D-5
66078	Strait-Line™ 1200 lbs. Round Bar (includes #66067 & #26002)	D-5
66082	Strait-Line™ 600 lbs. Trunnion Bar w/Shank (includes #66540, #54970 & #26002)	D-5
66083	Strait-Line™ 800 lbs. Trunnion Bar w/Shank (includes #66541, #54970 & #26002)	D-5
66084	Strait-Line™ 1200 lbs. Trunnion Bar w/Shank (includes #66542, #54970 & #26002)	D-5
66086	Strait-Line™ 600 lbs. Round Bar w/Shank (includes #65509, #54970 & #26002)	D-5
66087	Strait-Line™ 800 lbs. Round Bar w/Shank (includes #67509, #54970 & #26002)	D-5
66088	Strait-Line™ 1200 lbs. Round Bar w/Shank (includes #61009, #54970 & #26002)	D-5
66130	Strait-Line™ 1500 lbs. Trunnion Bar Hitch (includes #66131 & #26102)	D-5
66131	Ultra Frame™, Trunnion Bar Bolt-Together Wt.-Dist. Kit, 15,000 lbs. (GTW), 1,500 lbs. (TW)	A-5, D-7, D-11
66151	Reese SC 600 lbs. Trunnion Bar Wt. Dist. Kit & Built In Friction Sway Control w/#54970 Shank	D-6
66153	Reese SC 800 lbs. Trunnion Bar Wt. Dist. Kit & Built In Friction Sway Control w/#54970 Shank	D-6
66155	Reese SC 1200 lbs. Trunnion Bar Wt. Dist. Kit & Built In Friction Sway Control w/#54970 Shank	D-6
66157	Reese SC 1500 lbs. Trunnion Bar Wt. Dist. Kit & Built In Friction Sway Control w/#54970 Shank	D-6
6637	Wt. Dist. Part, Lift Unit Kit, (2) Brackets and Handle	D-18
66540	600 lbs. Adj. High-Performance Trunnion Style w/#54970 Shank	D-7
66541	800 lbs. Adj. High-Performance Trunnion Style w/#54970 Shank	D-7
66542	1200 lbs. Adj. High-Performance Trunnion Style w/#54970 Shank	D-7
6658	Grease Cap	M-17
6664	800 lbs. Trunnion Spring Bar Kit, (2) Spring Bars, Chains and Fasteners	D-11
6666	1200 lbs. Trunnion Spring Bar Kit, (2) Spring Bars, Chains and Fasteners	D-11
67 0801	Repair Kit- 2-5/16 Wedge Latch, Includes Latch, Lever, Ball Clamp, and Replacement Hardware	J-39
6709TEK	Brake Assembly - Alko 10" x 2-1/4" L/H	M-13, M-16
6710	Brake Assembly - Alko 10" x 2-1/4" R/H	M-13, M-16
6713	Brake Assembly - Alko 12" x 2" L/H	M-13, M-16
6714	Brake Assembly - Alko 12" x 2" R/H	M-13, M-16

PART NO.	DESCRIPTION	PAGE #
6715	Front Mount Receiver Accessory, Spare Tire Carrier	A-15
67300	HindSight Single Back Up Camera System w/Magnetic Base	M-23, N-2
67302	HindSight Single Back Up Camera, Channel 2	M-23, N-2
67303	HindSight Single Back Up Camera, Channel 3	M-23, N-2
67304	HindSight Single Back Up Camera, Channel 4	M-23, N-2
6730S00	Service Kit, Ratchet Repair - K/KX1550	J-62
6731S00	Service Kit, Ratchet Repair - K/KX1051	J-62
67509	800 lbs. Heavy Duty Round Bar WD Hitch w/#54970 Shank	D-8
6758	Front Mount Receiver Accessory, Work Step	A-15
6771	Front Mount Receiver Accessory, Receiver Tube Skid Shield	A-15
6810	Rotabroach Hole Cutting Tool, 1/2" Diameter	O-3
6811	Rotabroach Hole Cutting Tool, 9/16" Diameter	O-3
6811S00	Service Kit, 6" Plastic Wheel	J-35
6817P01	Winch Handle, 10"	J-62
6927	Primus™ Mounting Dash Clip	H-10
6955	Rail Kit for #6500 & #6501 Cargo Carriers	I-23
6980	Front Mount Receiver Accessory, Handle Kit for #6495 Winch Mounting Plate	A-15
7000	Battery Switch, 3 Terminal, 12 Volt Continuous Duty	N-7
7000100	Trailer Accessory, Tire Chocks (Order In 6 Pair Multiple Only)	M-24
7000-S	Battery Switch, 3 Terminal, 12 Volt Continuous Duty	N-7
7001	Battery Switch, 4 Terminal, 12 Volt Continuous Duty - Insulated	N-7
7001-S	Battery Switch, 4 Terminal, 12 Volt Continuous Duty - Insulated	N-7
700377	Pull Pin Assembly, 3/4" x 4"	J-26
7010	Rubber Economy Receiver Tube Cover w/"D" Logo for 2" Sq. Receivers	B-21
701029	Pull Pin Assembly, 7/8" x 5"	J-26
7010A	Circuit Breaker, 15 Amp	C-57
7010A-S	Circuit Breaker, 15 Amp	C-57
7011800300	Weld-On 2.5" O.D. Male Mount, 3/4" Pin for 190's	J-8
7011A	Circuit Breaker, 20 Amp	C-57
7011A-S	Circuit Breaker, 20 Amp	C-57
701292-01	DROP LEG & BASE 18.0	J-26
7012A	Circuit Breaker, 30 Amp	C-57
7012A-S	Circuit Breaker, 30 Amp	C-57
7013A	Circuit Breaker, 40 Amp	C-57
7013A-S	Circuit Breaker, 40 Amp	C-57
70-14-002	Door Bumper, Black	M-30
70-14-003	Door Bumper, White	M-30
70-14-110	Door Bumper Screw	M-30
701466	Crank Assembly, 2-Speed	J-16, J-27
701471	PULL PIN ASSY-3/4 X 3	J-26
701472	PULL PIN 9/16 X 2.75	J-26
702275	5-Flat Trailer End Connector, 25' Wishbone Harness, 4' Ground, 5' Auxiliary	C-34
7022A	Circuit Breaker, 50 Amp	C-57
7022A-S	Circuit Breaker, 50 Amp	C-57
702305	5-Flat Car End Connector, 4' Wishbone Harness, 18" Ground, 4' Auxiliary	C-34
702405	5-Flat Trailer End Connector, 18" Wunside Harness, 18" Ground, 18" Auxiliary	C-34
70-32-001	Assist Bar Lighted with Switch Chrome	K-58
70-32-002	Assist Bar Lighted (No Switch) Chrome	K-58
70-32-006	Assist Bar Lighted with Switch Black	K-58
70-32-030	Assist Bar Lens Only	K-58
70-32-041	Switch Push Button with 6" Wires (J-188A-1)	K-58
70-32-042	Rubber Boot for #70-32-041 Black	K-58
70-33-301	Assist Bar - Chrome	M-30
70-33-302	Assist Bar - Black	M-30
70-38-010	Reflector 3-3/16" Round Adhesive Mount Red	K-55
70-38-020	Reflector 3-3/16" Round Adhesive Mount Amber	K-55
7050	Rubber Economy Receiver Tube Cover w/"D" Logo for 2" Sq. Receivers, w/Header Card	B-21
70-55-010	Reflector 2-3/16" Round Adhesive Mount Red	K-55
70-55-020	Reflector 2-3/16" Round Adhesive Mount Amber	K-55
70-68-010	Reflector 3-3/16" Round Center Mount Red	K-55

NUMERICALS

PART NO.	DESCRIPTION	PAGE #
70-68-020	Reflector 3-3/16" Round Center Mount Amber	K-55
707103	4-Flat Trailer End Connector, 25' Wishbone Harness Kit, 3' Ground w/4' Car End, 18" Ground	C-29
707104	4-Flat Trailer End Connector, 30' Wishbone Harness Kit, 3' Ground w/4' Car End, 18" Ground	C-29
707105	5-Flat Trailer End Connector, 25' Wishbone Harness Kit w/ Hardware, 4' Ground, 5' Auxiliary, 6' Car End, 6' Ground, 6' Auxiliary	C-34
70-71-170	Reflector 2-3/16" Round Center Mount Red	K-55
70-71-175	Reflector 2-3/16" Round Center Mount Amber	K-55
70-71-180	Reflector Rectangular Red 3-1/4" x 1-1/2" - Adhesive	K-55
70-71-181	Reflector Rectangular Amber 3-1/4" x 1-1/2" - Adhesive	K-55
70-72-020	Reflector Clear Conspicuity 1.1" x 12"	K-55
70-72-030	Reflector Red Conspicuity 1.1" x 12"	K-55
707250	7-Way Blade to 5-Flat, 18" Wire Adapter	C-47
707254	4-Flat Extension Harness, 2' Long	C-29
707255	5-Flat Plug Loop 24" Long, Car & Trailer End Wiring Harness	C-34
707261	4-Flat Trailer End Connector, 25' Wishbone Harness, 3' Ground	C-29
707270	4-Flat Trailer End Connector, 18" Wishbone Harness, 18" Ground w/4' Car End, 18" Ground	C-29
707272	4-Flat Car End Connector 72" Long, 72" Ground (Includes Wire Taps)	C-29
707273	5-Flat Car End Connector, 6' Long, 6' Ground, 6' Auxiliary	C-34
707275	4-Flat Car End Connector 48" Long, 18" Ground	C-29
707281	6-Way Round Pin to 4-Flat Adapter	C-47
707282	7-Way Blade to 4-Flat Adapter	C-47
707283	5-Flat Trailer End Connector, 4' Wishbone Harness, 4' Ground, 4' Auxiliary	C-34
707285	4-Flat Trailer End Connector, 18" Wunside Harness, 18" Ground	C-29
707286	4-Flat Trailer End Connector, 18" Wishbone Harness, 18" Ground	C-29
707295	Taillight Converter w/12" Leads and 60" 4-Flat Car End Connector	C-27
70-78-010	Reflector Oblong Red with Mounting Holes and Adhesive Back	K-55
70-78-020	Reflector Oblong Amber with Mounting Holes and Adhesive Back	K-55
70-78-050	Reflector Oblong Red with Mounting Holes Only	K-55
70-78-060	Reflector Oblong Amber with Mounting Holes Only	K-55
71-55-010	Reflector 2-3/16" Round Adhesive Mount Red	K-55
71-55-020	Reflector 2-3/16" Round Adhesive Mount Amber	K-55
71-78-010	Reflector Rectangular Red 3-1/4" x 1-1/2" - Adhesive	K-55
71-78-020	Reflector Rectangular Amber 3-1/4" x 1-1/2" - Adhesive	K-55
719063	Plug, 3-Way 10-1/2"	K-8/11, K-21, K-26
7200	ElectroTek™ Non-Conductive Dielectric Silicone Compound, 3 Oz. Tube	C-57
7200P	ElectroTek™ Non-Conductive Dielectric Silicone Compound, 3 Oz. Tube	C-57
7330	Stretch Net Cargo Net for Cargo Carriers & Roof Rack	I-31
7390	Adjustable Ball Mount w/Sway Control Tab, 12" Length, 6,000 lbs. (GTW), 600 lbs. (TW)	B-11
74099	Receiver Tube Cover for 2" Sq., Elite Black Nylon	B-22
74-32-001	Assist Bar Lighted with Switch Chrome	K-58
74-32-002	Assist Bar Lighted (No Switch) Chrome	K-58
74-32-030	Assist Bar Lens Only	K-58
74-32-041	Switch Push Button with 6" Wires (J-188A-1)	K-58
74342	Wrench for Hitch Balls, Boxed Ends, 1-1/8" & 1-1/2"	B-13
74-38-010	Reflector 3-3/16" Round Adhesive Mount Red	K-55
74-38-020	Reflector 3-3/16" Round Adhesive Mount Amber	K-55
74547	Receiver Tube Cover for 2" Sq., Plastic	B-22
74-55-010	Reflector 2-3/16" Round Adhesive Mount Red	K-55
74-55-020	Reflector 2-3/16" Round Adhesive Mount Amber	K-55
74602	Quick Links, 5/16", 5,000 lbs.	M-26
74603	Quick Links, 1/4", 3,500 lbs.	M-26
74-68-010	Reflector 3-3/16" Round Center Mount Red	K-55
74-68-020	Reflector 3-3/16" Round Center Mount Amber	K-55
74700	Quick-Link Chain Hook-Up, Class III, 5/16"	M-26
74701	Quick-Link Chain Hook-Up, Class I and II, 1/4"	M-26
74-71-170	Reflector 2-3/16" Round Center Mount Red	K-55

PART NO.	DESCRIPTION	PAGE #
74-71-175	Reflector 2-3/16" Round Center Mount Amber	K-55
74-71-180	Reflector Rectangular Red 3-1/4" x 1-1/2" - Adhesive	K-55
74-71-181	Reflector Rectangular Amber 3-1/4" x 1-1/2" - Adhesive	K-55
74-72-020	Reflector Clear Conspicuity - 4 per	K-55
74-72-030	Reflector Red Conspicuity - 4 per	K-55
74-72-040	Reflector Red & Clear Conspicuity - 2 ea. Per	K-55
74-78-010	Reflector Oblong Red with Mounting Holes and Adhesive Back	K-55
74-78-020	Reflector Oblong Amber with Mounting Holes and Adhesive Back	K-55
7507	Folding Composite Cargo Carrier, 22" x 56" Platform, 2" Sq. Receiver Mount, 400 lbs. Capacity	I-21
7585	Tekonsha Bench Tester	O-2
7627	Universal Fit Ball Mount Bag, 17" Length, 6" Width, 2-3/4" Height	B-11
767940	7-Way Blade to 5-Flat Adapter	C-47
767941	4-Flat Car End Tester w/LED Display	O-2
767942	5-Flat Tester w/LED Display and Dust Cap	O-2
767943	7-Way Blade Tester and Trailer Emulator w/LED Display	O-2
7685	Prodigy® Mounting Bracket Kit	H-10
7686	Replacement Part, Prodigy® Mounting Pocket Kit	H-10
78007	7-Way Flat Pin to 4-Flat Adapter w/42" Retractable 4-Flat	C-49
78117	7-Way Flat Pin to 4-Flat Adapter w/Tow-Glo & Dust Cover	C-49
78118	7-Way Flat Pin to 4 & 5-Flat Adapter w/LED Circuit Tester & Dust Cover	C-49
781159	4-Flat Loop, 88" Jacketed Cable	C-32
781194	5-Flat To 5-Flat 4' Coiled Adapter	C-47
781195	7-Way Flat Pin to 5-Flat 4' Coiled Adapter	C-47
781196	7-Way Flat Pin to 5-Flat 8' Coiled Adapter	C-47
78206	5-Flat to 5-Flat Coiled Adapter, 4' Long	C-47
78207	7-Way Flat Pin to 5-Flat Coiled Adapter, 4' Long	C-47
78208	7-Way Flat Pin to 5-Flat Coiled Adapter, 8' Long	C-47
78264	4-Flat Trailer End Connector, 4' Jacketed Cable	C-32
78268	4-Flat Trailer End Connector, 8' Jacketed Cable	C-32
78270	4-Flat Trailer End Connector, 10' Jacketed Cable	C-32
78274	4-Flat Trailer End Connector, 14' Jacketed Cable	C-32
787301	4-Flat Dust Cover	C-33
787302	7-Way Round Pin Ag Trailer End Connector	C-43, K-29
787303	7-Way Round Pin Ag Vehicle End Connector	C-43, K-29
787304	7-Way Round Pin Ag Trailer End Connector	C-43, K-29
787305	7-Way Round Pin Ag Vehicle End Connector	C-43, K-29
787535	B JUNCT BOX 7-POS	C-54
7894	Replacement Part, Prodigy® and Primus™ 3 ft. Pigtail Harness Kit	H-10
7901	Trunnion Bar Bolt-Together Wt. Dist. Kit, 10,000 lbs. (GTW), 600 lbs. (TW)	D-11
7902	Trunnion Bar Bolt-Together Wt. Dist. Kit, 10,000 lbs. (GTW), 800 lbs. (TW)	D-11
7903	Trunnion Bar Bolt-Together Wt. Dist. Kit, 12,000 lbs. (GTW), 1200 lbs. (TW)	D-11
800075	Topwind Crank Assembly for 180	J-16, J-27
800090	Sidewind Crank Assembly for 180 - Horizontal Clevis - Mounting Hardware	J-16, J-27
800102	KIT 180 CRANK-NAR.CLEVIS HOR.	J-16, J-27
8001090283	KIT-HNDL W/HDWR-HD LND GR	J-20, J-27
800144	Kit, Assembly/Crank	J-28
80037	Class III/IV 2" Sq. Receiver Cover w/Hidden Hitch Logo, Rubber	B-21
80037-012	Class III/IV 2" Sq. Receiver Cover w/Hidden Hitch Logo, Rubber (12 pack)	B-21
8010	Trailer Tester	O-2
80100	Reducer Bushing 1" to 3/4"	B-13
80106	Reducer Bushing 1-1/4" to 1"	B-13
80122	Ball Mount, 12,000 lbs. GTW, 1-1/4" Ball Hole, 8-1/2" Length, 1" Rise, 2" Drop, Zinc - Solid Shank	B-9
80123	Ball Mount, 12,000 lbs. GTW, 1-1/4" Ball Hole, 8-1/2" Length, 3" Rise, 4" Drop, Zinc - Solid Shank	B-9
80124	Ball Mount, 12,000 lbs. GTW, 1-1/4" Ball Hole, 9-1/2" Length, 5" Rise, 6" Drop, Zinc - Solid Shank	B-9

NUMERICALS

PART NO.	DESCRIPTION	PAGE #
80125	Ball Mount, 12,000 lbs. GTW, 1-1/4" Ball Hole, 9-1/2" Length, 7" Rise, 8" Drop, Zinc - Solid Shank	B-9
80126	Ball Mount, 12,000 lbs. GTW, 1-1/4" Ball Hole, 12" Length, 3" Rise, 4" Drop, Zinc - Solid Shank	B-9
80127	Packaged Ball Mount, 6,000 lbs. GTW, 1" Ball Hole, 8-1/2" Length, 3/4" Rise, 2" Drop, w/Pin & Clip, Black	B-7
80132	Class IV Ball Mount, 10,000 lbs. GTW, 1-1/4" Ball Hole, 8-1/2" Length, 3/4" Rise, 2" Drop, Black - Hollow Shank	B-9
80133	Class IV Ball Mount, 10,000 lbs. GTW, 1-1/4" Ball Hole, 9" Length, 2-3/4" Rise, 4" Drop, Black - Hollow Shank	B-9
80136	Class IV Ball Mount, 10,000 lbs. GTW, 1-1/4" Ball Hole, 11-1/4" Length, 2-3/4" Rise, 4" Drop, Black - Hollow Shank	B-9
80137	Class IV Ball Mount, 10,000 lbs. GTW, 1-1/4" Ball Hole, 9" Length, 6" Drop, Black - Hollow Shank	B-9
80138	Class IV Ball Mount, 10,000 lbs. GTW, 1-1/4" Ball Hole, 9" Length, 8" Drop, Black - Hollow Shank	B-9
80139	Packaged Ball Mount, 6,000 lbs. GTW, 1" Ball Hole, 9" Length, 2-3/4" Rise, 4" Drop, w/Pin & Clip, Black	B-7
80142	Forged Ball Mount, 16,000 lbs. GTW, 1-1/4" Ball Hole, 8-1/2" Length, 1" Rise, 2" Drop, Black	B-8
80143	Forged Ball Mount, 16,000 lbs. GTW, 1-1/4" Ball Hole, 9-1/4" Length, 3" Rise, 4" Drop, Black	B-8
80144	Forged Ball Mount, 16,000 lbs. GTW, 1-1/4" Ball Hole, 10-1/4" Length, 5" Rise, 6" Drop, Black	B-8
80213	Class III Ball Mount, 5,000 lbs. GTW, 1" Ball Hole, 10" Length, 6-3/4" Rise, 8" Drop, Black	B-7
80213-002	Class III Ball Mount, 5,000 lbs. GTW, 1" Ball Hole, 10" Length, 6-3/4" Rise, 8" Drop, Black (2 pack)	B-7
80226	Angle Cut Class III Ball Mount, 6,000 lbs. GTW, 1" Ball Hole, 10-1/2" Length, 3/4" Rise, 2" Drop, Black	B-7
80226-006	Angle Cut Class III Ball Mount, 6,000 lbs. GTW, 1" Ball Hole, 10-1/2" Length, 3/4" Rise, 2" Drop, Black (6 pack)	B-7
80227	Angle Cut Class III Ball Mount, 6,000 lbs. GTW, 1" Ball Hole, 8-1/2" Length, 3/4" Rise, 2" Drop, Black	B-7
80227-006	Angle Cut Class III Ball Mount, 6,000 lbs. GTW, 1" Ball Hole, 8-1/2" Length, 3/4" Rise, 2" Drop, Black (6 pack)	B-7
80228	Angle Cut Class III Ball Mount, 6,000 lbs. GTW, 1" Ball Hole, 11-1/4" Length, 2-3/4" Rise, 4" Drop, Black	B-7
80228-006	Angle Cut Class III Ball Mount, 6,000 lbs. GTW, 1" Ball Hole, 11-1/4" Length, 2-3/4" Rise, 4" Drop, Black (6 pack)	B-7
80232	Angle Cut Class III Ball Mount, 6,000 lbs. GTW, 1" Ball Hole, 16" Length, 3/4" Rise, 2" Drop, Black	B-7
80233	Angle Cut Class III Ball Mount, 6,000 lbs. GTW, 1" Ball Hole, 16" Length, 2-3/4" Rise, 4" Drop, Black	B-7
80239	Class III Ball Mount, 6,000 lbs. GTW, 1" Ball Hole, 9" Length, 2-3/4" Rise, 4" Drop, Black	B-7
80239-006	Class III Ball Mount, 6,000 lbs. GTW, 1" Ball Hole, 9" Length, 2-3/4" Rise, 4" Drop, Black (6 pack)	B-7
80240	Class III Ball Mount, 6,000 lbs. GTW, 1" Ball Hole, 9-3/4" Length, 4-3/4" Rise, 6" Drop, Black	B-7
80248	Ball Mount, 5,000 lbs. GTW (Drop Position) & 3,500 GTW (Rise Position), 1" Ball Hole, 9" Length, 9-3/4" Rise, 11" Drop, Black	B-7
802650	Replacement Amber Lens for #82600 Series Ag Light	C-46, K-28
802651	Replacement Red Lens for #82600 Series Ag Light	C-46, K-28
802652	Replacement Black/Blank Lens for #82600 Series Ag Light	C-46, K-28
80300	Receiver Adapter, Reduces 2" to 1-1/4", 7" Length, 3,500 lbs.	B-13
80301	Receiver Adapter, Reduces 2" to 1-1/4", 14" Length, 3,500 lbs.	B-13
80303	Receiver Adapter, 1-1/4" to 2", 6" Length, 3,500 lbs., Class II Only	B-13
80304	Receiver Adapter, 1-1/4" to 2", 10" Length, 3,500 lbs., Class II Only	B-13
80305	Receiver Extension, 2" to 2" Extension, 14" Length, 3,500 lbs.	B-13
80306	Receiver Extension, 2" to 2" Extension, 18" Length, 3,500 lbs.	B-13
80307	Receiver Extension, 2" to 2" Extension, 8" Length, 3,500 lbs.	B-13
80400	Bumper Guard, Black	B-13
80404	Dual-Ball Ball Mount, 2" Sq. Hollow Shank, 10" Length, w/Black 1-7/8" (Rise) & 2" (Drop) Balls, Black	B-12
80405	Dual-Ball Ball Mount, 2" Sq. Hollow Shank, 10" Length, w/Black 1-7/8" (Drop) & 2" (Rise) Balls, Black	B-12
80406	Dual-Ball Ball Mount, 2" Sq. Hollow Shank, 10" Length, w/Black 2" (Drop) & 2-5/16" (Rise) Balls, Black	B-12

PART NO.	DESCRIPTION	PAGE #
80410	Clevis Ball Mount, 11" Length, Rating 6,000/600 lbs. as Ball Mount w/1-1/4" Drop, Rating 6,000/600 lbs. as Clevis Mount w/3" Drop, 1" Holes, Black Finish	B-16
80412	Adjustable Ball Mount, 6,000 lbs. GTW, 1" Ball Hole, 12" Length, 8-3/8" Rise, 9-5/8" Drop, Black	B-11
80414	Adjustable Ball Mount, 6,000 lbs. GTW, 1" Ball Hole, 14" Length, 8-3/8" Rise, 9-5/8" Drop, Black	B-11
80417	Replacement Part, Adjustable Ball Mount, Shank Only	B-11
80418	Replacement Part, Adjustable Ball Mount, Ball Mount Plate Only	B-11
80420	Cushioned Ball Mount, 10,000 lbs. GTW, 1" Ball Hole, 9-3/8" Length, 3/4" Rise, 2" Drop	B-10
80421	Cushioned Ball Mount, 10,000 lbs. GTW, 1" Ball Hole, 9-7/8" Length, 2-3/4" Rise, 4" Drop	B-10
80422	Cushioned Ball Mount, 10,000 lbs. GTW, 1" Ball Hole, 10-5/8" Length, 4-3/4" Rise, 6" Drop	B-10
80425	Tri-Ball Ball Mount, 2" Sq. Hollow Shank w/Black 1-7/8", 2", & 2-5/16" Balls - Black	B-12
80426	Tri-Ball Ball Mount, 2" Sq. Hollow Shank w/Chrome 1-7/8", 2", & 2-5/16" Balls - Black	B-12
80470	Bumper Guard, Diamond Plate	B-13
80500	POD® Brake Control, for 1 to 2 Axle Trailers, Timed Actuated	H-9
80550	Pilot® Brake Control, for 1 to 3 Axle Trailers, Timed Actuated	H-9
80563-002	Towing Starter Kit, w/Quick-Loading 2" Sq. Ball Mount, 6,000 lbs. GTW, 1" Ball Hole, 8-1/2" Length, 3/4" Rise, 2" Drop & 2" Chrome Hitch Ball w/Pin & Clip (2 Pack)	B-10
80565	Towing Starter Kit, w/Interlock™ (Hex) Feature Ball Mount 2" Sq. x 8-1/2" L x 2"D x 3/4" R, 6000 lbs. & 2" Hitch Ball w/Bent Pin Barrel Receiver Locks, Plastic Storage Case	B-10
80570-002	Towing Starter Kit, w/Quick-Loading 2" Sq. Ball Mount, 6,000 lbs. GTW, 1" Ball Hole, 9" Length, 2-3/4" Rise, 4" Drop & 2" Chrome Hitch Ball w/Pin & Clip	B-10
80791	Tri-Ball Ball Mount, 2" Sq. Solid Shank w/Black 1-7/8", 2", & 2-5/16" Balls, Black	B-12
80795	Dual-Ball Ball Mount, 2" Sq. Solid Shank, 8" Length, w/Black 1-7/8" & 2" Balls, Black	B-12
80796	Dual-Ball Ball Mount, 2" Sq. Solid Shank, 8" Length, w/Black 2" & 2-5/16" Balls, Black	B-12
80797	Dual-Ball Ball Mount, 2" Sq. Solid Shank, 8" Length, w/Chrome 1-7/8" & 2" Balls, Black	B-12
80798	Dual Ball Ball Mount, 2" Sq. Solid Shank, 8" Length, w/Chrome 2" & 2-5/16" Balls, Black	B-12
80799	Tri-Ball Ball Mount, 2" Sq. Solid Shank w/Chrome 1-7/8", 2", & 2-5/16" Balls, Black	B-12
80806	Receiver Fabrication Part, 6" Combo Bar 2" Sq. ID w/Collar, Painted	A-16
80812	Receiver Fabrication Part, 12" Combo Bar 2" Sq. ID w/Collar, Painted	A-16
80818	Receiver Fabrication Part, 18" Combo Bar 2" Sq. ID w/Collar, Painted	A-16
80953	Receiver Tube Cover, 2" Sq., Black Plastic	B-22
80961	Receiver Tube Cover, 2" Sq., Chrome Plastic	B-21
80980	Receiver Tube Cover, 2" Sq., Brake Light w/4-Flat Plug	B-22
81378	Step Bumper Receiver, Class II 2" Sq. Universal Fit, 3,500 lbs. GTW/350 lbs. TW, Black	A-14
82000	Class III & IV Receiver (82xxx Series) - Multi-Fit	A-8
82200	Multi-Fit Motor Home Hitch, Fits Frames 31" to 46" Wide, Black, 5,000 lbs. WC, 6,000 lbs. WD	A-14
82201	Multi-Fit Motor Home Hitch, Fits Frames 47" to 71" Wide, Black, 3,500 lbs. WC	A-14
82571	Class III & IV Receiver (82xxx Series)	A-14
82574	Class III & IV Receiver (82xxx Series)	A-14
82575	Class III & IV Receiver (82xxx Series)	A-14
8260001	Dual Ag Light w/Amber/Red/Blank, Includes Left Hand Molded Tri-Plug	C-46, K-28
8260101	Dual Ag Light w/Red/Blank Amber/Amber, Includes Right Hand Molded Tri-Plug	C-46, K-28
8260501	Ag Light, Single w/Red/Black, Includes Molded Tri-Plug	C-46, K-28
8260601	Ag Light, Single w/Amber/Amber, Includes Molded Tri-Plug	C-46, K-28
8261001	Ag Light, Single w/Red/Black w/ Brake Light Function, Includes Molded Tri-Plug	C-46, K-28
8261501	Dual Ag Light w/Amber/Amber Red/Blank w/Brake Light Function, Includes Left Hand Molded Square 4 Plug	C-46, K-28

NUMERICALS

PART NO.	DESCRIPTION	PAGE #
8261601	Dual Ag Light w/Red/Blank Amber/Amber w/Brake Light Function, Includes Right Hand Molded Square 4 Plug	C-46, K-28
83001	Elite™ Series Fifth Wheel 12" Lube Plate	E-15
83002	Fifth Wheel 10" Lube Plate	E-15
8339	Fold-Down Gooseneck Hitch w/2-5/16" Ball, Rating 25,000 lbs.	G-7, G-9, G-13/18
83500	Brakeman™ Digital Brake Control, for 1 to 4 Axle Trailers, Timed Actuated	H-6
83501	Brakeman™ Compact Brake Control, for 1 to 2 Axle Trailers, Timed Actuated	H-6
83520	Brakeman™ Ultra Brake Control, for 1 to 4 Axle Trailers, Timed Actuated	H-6
83563-002	Towing Starter Kit, w/Quick-Loading 2" Sq. Ball Mount, 6,000 lbs. GTW, 1" Ball Hole, 8-1/2" Length, 3/4" Rise, 2" Drop & 2" Chrome Hitch Ball w/Pin & Clip (2 Pack)	B-10
83565	Towing Starter Kit, w/Interlock™ (Hex) Feature Ball Mount 2" Sq. x 8-1/2"L x 2"D x 3/4"R, 6000 lbs. & 2" Hitch Ball w/Bent Pin Barrel Receiver Locks, Plastic Storage Case	B-10
83570-002	Towing Starter Kit, w/Quick-Loading 2" Sq. Ball Mount, 6,000 lbs. GTW, 1" Ball Hole, 9" Length, 2-3/4" Rise, 4" Drop & 2" Chrome Hitch Ball w/Pin & Clip	B-10
83637	Drawbar Kit for OEM Dodge Magnum Hitch, Drawbar (2000 lbs. w/3/4" Ball Hole), Pin and Clip, Black	B-5
83660	Pro Series Friction Sway Control	D-16
85-767010	Chrome Trim Snap Ring	K-11
9002200	Bungee Cord Assortment (20 piece)	I-36
9002600	Bungee Cord Assortment (18 piece)	I-36
9002900	Fat Strap Cord Assortment (6 piece) (2) Blue 15", (2) Red 20" & (2) Green 30"	I-36
90-03-327	Replacement Part, Clearance Light Lens Red with Screw	K-43
90-03-328	Replacement Part, Clearance Light Lens Amber with Screw	K-43
90-03-336	Taillight and Clearance Light Replacement Lens Set with Screw	K-22
9008400	Stretch Cord Assortment - 24 pc.	I-36
9008600	Bungee Cord Assortment - 12 pc.	I-36
9009500	Stretch Cord Assortment - 6 pc.	I-36
9009600	Stretch Cord Assortment - 8 pc.	I-36
9010500	Ratchet Tie Down - 1" x 10' (4 pack)	I-35
90160	Primus™ IQ Electronic Brake Control, for 1 to 3 Axle Trailers, Proportional	H-5
90195	P3® Electronic Brake Control, for 1 to 4 Axle Trailers, Proportional	H-4
90250	Prodigy® RF Electronic Brake Control, for 1 to 3 Axle Trailers, Trailer Mounted, Proportional	H-3
90251	Replacement Part, Prodigy® RF Hand Held Remote	H-3
9030	Voyager® Electronic Brake Control, for 1 to 4 Axle Trailers, Proportional	H-5
9052000	Mini Stretch Cord Assortment - 20 pc.	I-36
90885	Prodigy® P2 Electronic Brake Control, for 1 to 4 Axle Trailers, Proportional	H-4
9133900	Tarp Strap Assortment - 6 pc. - (2) 15", (2) 21", (2) 31"	I-37
9142000	Adjustable Cargo Bar w/Storage Net 40" to 74"	I-32
9142200	Adjustable Clothes Hanger Bar 36" to 65"	I-30
9155000	Bed Anchor Kit - 3/8", 1400 lbs.	N-4
9180200	Cambuckle Tie Down - 1" x 6' (4 pack)	I-35
9201800	Stretch Cord - 18" (2 pack)	I-36
9203200	Stretch Cord - 32" (2 pack)	I-36
9210500	Ratchet Tie Down - 1" x 10' (4 pack)	I-35
9210600	Cambuckle Tie Down - 1" x 6', 900 lbs. - Blue (4 pack)	I-35
9231300	Lashing Strap w/Spring - 12', 300 lbs.	I-35
9232400	Stretch Cord - 24" (2 pack)	I-36
9235P01	Winch Handle, 10"	J-62
9250900	Anchor Point - Chrome	N-4
9252200	Anchor Point, fits all Chevrolet/GMC Silverado/Sierra, 1994-Current Dodge RAM	N-4
9302400	Triple Strength Stretch Cord - 24"	I-36
9303200	Triple Strength Stretch Cord - 32"	I-36
9304000	Triple Strength Stretch Cord - 40"	I-36
9305200	Triple Strength Stretch Cord - 52"	I-36
9402400	Stretch Cord - 24"	I-36

PART NO.	DESCRIPTION	PAGE #
9412000	Fat Strap Cord - 20"	I-36
9413000	Fat Strap Cord - 30"	I-36
9414500	Fat Strap Cord - 45"	I-36
9414900	Adjustable Fat Strap - 10" to 45", Orange/Black	I-36
9460	Hide-A-Goose Wide Head	G-7, G-13/15
9460-39	Hide-A-Goose Complete Kit, Dodge	G-13/15
9460-48	Hide-A-Goose Complete Kit, Ford	G-13/15
9460-49	Hide-A-Goose Complete Kit, Ford	G-13/15
94621	Goose Box For Lippert #1621 & #1716 Wing Sets	F-3, G-3
94622	Goose Box For Lippert #1621 & #1716 Wing Sets	F-3, G-3
9464	Hide-A-Goose Wide Head Only	G-7, G-13/15
9464-35	Hide-A-Goose Complete Kit, Dodge	G-13/15
9464-38	Hide-A-Goose Complete Kit, Dodge	G-13/15
9464-46	Hide-A-Goose Complete Kit, Dodge	G-13/15
9465	Hide-A-Goose Narrow Head	G-7, G-13/15
9465-34	Hide-A-Goose Complete Kit, GM	G-13/15
9465-36	Hide-A-Goose Complete Kit, Toyota	G-13/15
9465-37	Hide-A-Goose Complete Kit, Ford	G-13/15
9465-40	Hide-A-Goose Complete Kit, GM	G-13/15
9465-45	Hide-A-Goose Complete Kit, GM	G-13/15
9465-54	Hide-A-Goose Complete Kit, GM	G-13/15
9465-56	Hide-A-Goose Complete Kit, GM	G-13/15
9470	Under-Bed Gooseneck Wide Head	G-9, G-16/18
9470-39	Under-Bed Gooseneck Complete Kit, Dodge	G-16/18
9470-48	Under-Bed Gooseneck Complete Kit, Ford	G-16/18
9470-49	Under-Bed Gooseneck Complete Kit, Ford	G-16/18
9474	Under-Bed Gooseneck Wide Head	G-9, G-16/18
9474-35	Under-Bed Gooseneck Complete Kit, Dodge	G-16/18
9474-38	Under-Bed Gooseneck Complete Kit, Dodge	G-16/18
9474-46	Under-Bed Gooseneck Complete Kit, Dodge	G-16/18
9475	Under-Bed Gooseneck Narrow Head	G-9, G-16/18
9475-34	Under-Bed Gooseneck Complete Kit, GM	G-16/18
9475-36	Under-Bed Gooseneck Complete Kit, Toyota	G-16/18
9475-37	Under-Bed Gooseneck Complete Kit, Ford	G-16/18
9475-40	Under-Bed Gooseneck Complete Kit, GM	G-16/18
9475-45	Under-Bed Gooseneck Complete Kit, GM	G-16/18
9475-54	Under-Bed Gooseneck Complete Kit, GM	G-16/18
9475-56	Under-Bed Gooseneck Complete Kit, GM	G-16/18
9480	Hide-A-Goose 18K Hi-Rise™ Fifth Wheel Conversion Hitch	G-8
9480000	Motorcycle Cover w/Storage Bag, Fits Touring Cycles Up To 1500cc	I-29
9481	Under-Bed Gooseneck 18K Hi-Rise™ Fifth Wheel Conversion Hitch	G-10
9480100	Car Cover w/Storage Bag, Fits Full Size Cars From 191" to 210"	I-29
9500100	Cargo Net - 36" x 48"	I-32
9500500	Cargo Net - Pickup Truck - 60" x 78"	I-32
9500600	Universal Heavy Duty Truck Net	I-32
9500700	Tailgate Net - Mini/Mid Size Pickup - 52" x 16"	I-31
9500800	Tailgate Net - Full Size Pickup - 56" x 18-1/2"	I-31
9500900	Spare Tire Cover - 27" to 29"	I-29
9501000	Bulkhead/Trunk Storage Net - 48" to 60" x 12"	I-32
9501200	Hammock Style Storage Net - 45" to 60" x 24"	I-32
9501300	3 Pocket Storage Net - 48" to 60" x 13"	I-32
9501400	Spare Tire Cover - 30" to 32"	I-29
9501500	Turbo Net, Full Size Truck	I-31
9502200	V-Net 2000 - 62" to 64" - Newer Vehicles, for Fifth Wheel	I-31
9502600	Turbo Trunk Small Interior Organizer	I-30
98929-2012	General Product Catalog	P-12
98931-2012	General Product Application/Technical Catalog	P-12
A2003C0317	Adjustable Coupler, Cast Head, w/Hardware, 3 Position Channel, 8000 lbs.	J-39
A2005C0317	Adjustable Coupler, Cast Head, w/Hardware, 5 Position Channel, 8000 lbs.	J-39
A200C 0317	Adjustable Coupler, Cast Head, w/Hardware, Less Channel, 8000 lbs. - Primed	J-39

NUMERICALS

PART NO.	DESCRIPTION	PAGE #
A200S 0303	Adjustable Coupler w/Hardware, Less Channel, 8000 lbs. - Black	J-40
A2563C0317	Adjustable Coupler, Cast Head, w/Hardware, 3 Position Channel, 14,000 lbs.	J-39
A2565C0317	Adjustable Coupler, Cast Head, w/Hardware, 5 Position Channel, 14,000 lbs.	J-39
A256C 0317	Adjustable Coupler, Cast Head, w/Hardware, Less Channel, 14,000 lbs. - Primed	J-39
A256S 0303	Adjustable Coupler w/Hardware, Less Channel, 14,000 lbs. - Black	J-40
AC300 0300	4 Hole, 3 Position Channel, w/8" Height	J-39/40
AC500 0300	6 Hole, 5 Position Channel, w/11-3/4" Height	J-39/40
BB17810112	Bearing Protector Covers, 1.781"	M-20
BB19800112	Bearing Protector Covers, 1.980"	M-20
BB24410112	Bearing Protector Covers, 2.328" & 2.441"	M-20
BGR20 0101	Roller Guides	M-29
BP232S0604	Bearing Protector, 2.328"	M-20
BP244S0604	Bearing Protector, 2.441"	M-20
BPC1780604	Bearing Protector, 1.781" w/Covers	M-20
BPC1980604	Bearing Protector, 1.980" w/Covers	M-20
CA5550301	Caster Adapter Plate - used w/HC1 & HDC1	J-25
CE555 0101	6" Caster - Fits 2" Round Inner Tube - 1200 lbs.	J-8, J-25
CE555 0301	6" Caster - Fits 2" Round Inner Tube - 1200 lbs. Zinc	J-8, J-25
CH 0701	Coupler Handle, Carded	J-48
CHA0010140	Safety Chain, Grade 30, 1/4" x 24" w/S-Hook w/Latch	M-25
CHA0010340	Safety Chain, Grade 30, 1/4" x 24" w/ 7/16" Wire Safety Latch	M-25
CHA0020324	Safety Chain, Grade 70, 1/4" x 36" w/ 1/4" Clevis Hook	M-25
CHA0030140	Safety Chain, Grade 43, 1/4" x 24" w/S-Hook w/Latch	M-25
CHA0030340	Safety Chain, Grade 43, 1/4" x 24" w/ 7/16" Wire Safety Latch	M-25
CHA0040324	Safety Chain, Grade 70, 5/16" x 36" w/ 5/16" Clevis Hook	M-25
CHA0050324	Safety Chain, Grade 70, 5/16" x 42" w/ 5/16" Clevis Hook	M-25
CHA0060324	Safety Chain, Grade 70, 3/8" x 36" w/ 3/8" Clevis Hook	M-25
CHA0070324	Safety Chain, Grade 70, 1/2" x 42" w/ 1/2" Clevis Hook	M-25
CLK15 0100	Cable Lock w/Key, 15'	L-6
CLK6 0700	Cable Lock w/Key, 6'	L-6
CP555 0301	6" Caster - Fits 2" Round Inner Tube - 1500 lbs.	J-25
CR8008	Bunk Carpeting, 8" x 144"	M-29
CR8012	Bunk Carpeting, 12" x 144"	M-29
CS730300	Cross Shaft Extension Tube 72.75"	J-16, J-20
DF35000324	Drop Leg 3,500 lbs. SQ Tube	J-26
E112000340	Coupler, Straight Channel, Ball Size 1-7/8", 2" Tongue Mount Width, Zinc Finish, Rating 2,000 lbs.	J-48
E112500340	Coupler, Straight Channel, Ball Size 1-7/8", 2-1/2" Tongue Mount Width, Zinc Finish, Rating 2,000 lbs.	J-48
E113000340	Coupler, Straight Channel, Ball Size 1-7/8", 3" Tongue Mount Width, Zinc Finish, Rating 2,000 lbs.	J-48
E333050303	Coupler, A-Frame, 5000 lbs., Class III, Value Series, Black Primer, 2" Ball	J-48
E338050303	Coupler, A-Frame, Yoke-Style, 5000 lbs., Class III, Black Primer, 2" Ball	J-40
E443050303	Coupler, A-Frame, 10,000 lbs., Class IV, Value Series, Black Primer, 2-5/16" Ball	J-48
EA20000103	2000 lbs., TW, A-Frame, 14" Travel, Black	J-9
EA20000303	2000 lbs., TW, A-Frame, 14" Travel, Black	J-9
EA20000340	Jack, 2000 lbs., A-Frame	J-9
EJ10000101	1000 lbs., Swivel, Zinc Plated, 6" Poly Wheel	J-32
EJ10000301	1000 lbs., Swivel, Zinc Plated, 6" Poly Wheel	J-32
EM0101	EZMOVE w/Support Bracket	M-24
ETC 0101	Spare Tire Carrier, Economy	M-27
ETCHL 0700	Spare Tire Carrier with Bracket	M-27
ETCLB 0201	Spare Tire Carrier, Economy w/Locking Brackets	M-27
ETCLB 0700	Spare Tire Carrier, Economy w/Locking Brackets	M-27
ETCSTL0701	Spare Tire Carrier, Economy w/Lock (STL Lock Included)	M-27
FP20000201	Disc Foot w/Hardware - 2,000 lbs.	J-26
FW16000101	F2 Winch, 1600 lbs., w/Strap	J-53
FW16000301	F2 Winch, 1600 lbs. (Strap Sold Separately)	J-53
FW20000101	F2 Winch, 2000 lbs., w/Strap	J-54
FW20000301	F2 Winch, 2000 lbs., w/Strap	J-54

PART NO.	DESCRIPTION	PAGE #
FW32000101	F2 Winch, 2-Speed, 3200 lbs., w/Strap	J-54
FW32000301	F2 Winch, 2-Speed, 3200 lbs., w/Strap	J-54
GB150 0100	Boat Guide, 50"	M-29
GB44 0101	Boat Guide, 44"	M-29
GN24 0200	24K Cast Gooseneck Coupler Kit	J-42
HD25000101	2500 lbs., Square Tube, Fixed Mount	J-35
HD50000101	5000 lbs., Square Tube, Fixed Mount	J-35
HD50000301	5000 lbs., Square Tube, Fixed Mount	J-35
HDPB230101	Fold-Away Bolt-On Hinge Kit, 2" x 3" Trailer Beam, Zinc Finish, Rating 5,000 lbs.	J-50
HDPB230301	Fold-Away Bolt-On Hinge Kit, 2" x 3" Trailer Beam, Zinc Finish, Rating 5,000 lbs.	J-50
HDPB330101	Fold-Away Bolt-On Hinge Kit, 3" x 3" Trailer Beam, Zinc Finish, Rating 5,000 lbs.	J-50
HDPB330301	Fold-Away Bolt-On Hinge Kit, 3" x 3" Trailer Beam, Zinc Finish, Rating 5,000 lbs.	J-50
HDPB340101	Fold-Away Bolt-On Hinge Kit, 3" x 4" Trailer Beam, Zinc Finish, Rating 7,500 lbs.	J-50
HDPB340301	Fold-Away Bolt-On Hinge Kit, 3" x 4" Trailer Beam, Zinc Finish, Rating 7,500 lbs.	J-50
HDPB350101	Fold-Away Bolt-On Hinge Kit, 3" x 5" Trailer Beam, Zinc Finish, Rating 9,000 lbs.	J-50
HDPB350301	Fold-Away Bolt-On Hinge Kit, 3" x 5" Trailer Beam, Zinc Finish, Rating 9,000 lbs.	J-50
HDPW230300	Fold-Away Weld-On Hinge Kit, 2" x 3" Trailer Beam, Raw Finish, Rating 5,000 lbs.	J-50
HDPW330300	Fold-Away Weld-On Hinge Kit, 3" x 3" Trailer Beam, Raw Finish, Rating 5,000 lbs.	J-50
HDPW340300	Fold-Away Weld-On Hinge Kit, 3" x 4" Trailer Beam, Raw Finish, Rating 7,500 lbs.	J-50
HDPW350300	Fold-Away Weld-On Hinge Kit, 3" x 5" Trailer Beam, Raw Finish, Rating 9,000 lbs.	J-50
HDSTC 0101	Spare Tire Carrier, Heavy Duty	M-27
HPB3530101	Fold-Away 34" Coupler Kit, Ball Size 2", 3" x 3" Trailer Beam, Zinc Finish, Rating 3,500 lbs.	J-50
HPB3530301	Fold-Away 34" Coupler Kit, Ball Size 2", 3" x 3" Trailer Beam, Zinc Finish, Rating 3,500 lbs.	J-50
HPB3540101	Fold-Away 34" Coupler Kit, Ball Size 2", 3" x 4" Trailer Beam, Zinc Finish, Rating 3,500 lbs.	J-50
HPB3540301	Fold-Away 34" Coupler Kit, Ball Size 2", 3" x 4" Trailer Beam, Zinc Finish, Rating 3,500 lbs.	J-50
HPB5040101	Fold-Away 34" Coupler Kit, Ball Size 2", 3" x 4" Trailer Beam, Zinc Finish, Rating 5,000 lbs.	J-50
HPB5040301	Fold-Away 34" Coupler Kit, Ball Size 2", 3" x 4" Trailer Beam, Zinc Finish, Rating 5,000 lbs.	J-50
K1051 0101	Winch, 1000 lbs., 2-Speed	J-60
K1051 0301	Winch, 1000 lbs., 2-Speed	J-60
K1550 0101	Brake Winch, 1500 lbs.	J-60
K1550 0301	Brake Winch, 1500 lbs.	J-60
K2550 0101	Brake Winch, 2500 lbs.	J-60
K2550 0301	Brake Winch, 2500 lbs.	J-60
K650 0101	Brake Winch, 600 lbs.	J-60
K650 0301	Brake Winch, 600 lbs.	J-60
KR10000301	Brake Winch, 1000 lbs., Standard Series	J-61
KR15000301	Brake Winch, 1500 lbs., Standard Series	J-61
KW15000103	Worm Gear Winch, 1500 lbs.	J-61
KW20000103	Worm Gear Winch, 2000 lbs.	J-61
KW30000103	Worm Gear Winch, 3000 lbs.	J-61
KX10510101	Brake Winch, 1000 lbs.	J-60
KX10510301	Deluxe Brake Winch, 1000 lbs.	J-60
KX15500101	Deluxe Brake Winch, 1500 lbs.	J-60
KX15500301	Deluxe Brake Winch, 1500 lbs.	J-60
KX20000301	Brake Winch, 2000 lbs.	J-60
LPOG31001	Bargman 4' x 4' Combined Lighting Planogram	K-63
LPOG31002	Bargman 2' x 4' LED Lighting Planogram	K-63
LPOG31003	Bargman 3' x 4' Incandescent Lighting Planogram	K-63
MKG0156	TEK Voyager DVD	P-12
MKG0158	TEK Prodigy P2 DVD	P-12
MKG0159	TEK Primus IQ DVD	P-12

NUMERICALS

PART NO.	DESCRIPTION	PAGE #
MKG0160	TEK P3 DVD	P-12
MKG0161	TEK Prodigy RF DVD	P-12
MKG0162	RS WD DVD	P-12
MKG0163	Reese® Flip Chart for Hitch Display Rack #37-0030	P-2
MKG0164	DT I-Stop IQ DVD	P-12
MKG0182	Plastic Inside Sign, 15" x 30"	P-8
MKG0183	Banner, 21" x 72"	P-9
MKG0185	Shelf Sign, 3" x 24" for Lozier Gondola #37-5367	P-8
MKG0186	Header Card, 8" x 24" for Lozier Gondola #37-5367	P-8
MKG0187	TEK Wallpaper	P-7
MKG0188	TEK 2' Header Sign	P-8
MKG0189	TEK 4' Header Sign	P-8
MKG0190	TEK BC Counter Mat	P-9
MKG0191	Fulton Wallpaper	P-7
MKG0192	Fulton 2' Header	P-8
MKG0193	Fulton 4' Header	P-8
MKG0195	DT 8" x 11" Window Decal	P-10
MKG0196	DT Tested Tough Banners	P-9
MKG0197	Accessories Merchandising Display Header Sign - Large for #37-5364	P-8
MKG0198	Hours of Operation Sign	P-11
MKG0200	Accessories Merchandising Display Header Sign - Large for #37-5364	P-8
MKG0201	Accessories Merchandising Display Header Sign - Small for #37-6474	P-8
MKG0202	RS HD Spec. Banner	P-9
MKG0204	Brake Control Display Header Labels	P-5
MKG0205	Header Card for Hitch Display Stand #37-0031, 12" x 42"	P-8
MKG0206	Why Buy Reese Poster 24" x 36"	P-9
MKG0207	Fifth Wheel DVD	P-12
MKG0208	RS Show Bags	P-11
MKG0209	Bulldog® Merchandising Sign	P-8
MKG0210	BD Wallpaper	P-7
MKG0211	Bulldog 2' Header	P-8
MKG0212	BD 4' Header	P-8
MKG0213	Window Decal, Gooseneck Hitches, 4" x 6"	P-10
MKG0214	Counter Mat, Gooseneck Hitches	P-9
MKG0215	DT Show Bag	P-11
MKG0216	Hours of Operation Sign	P-11
MKG0217	Accessories Merchandising Display Header Sign - Small for #37-6474	P-8
MKG0218	Draw-Tite Sign for #37-2103	P-3, P-8
MKG0219	Header Card for Hitch Display Stand #37-0031, 12" x 42"	P-8
MKG0220	Brake Control Display Header Labels	P-5
MKG0221	Draw-Tite® Flip Chart for Hitch Display Rack #37-0030	P-2
MKG0223	Window Decal, Gooseneck Hitches, 4" x 6"	P-10
MKG0224	Counter Mat, Gooseneck Hitches	P-9
MKG0225	DT Wallpaper	P-7
MKG0226	DT Tested Tough Counter Mat	P-9
MKG0227	DT Tested Tough Banner (French)	P-9
MKG0230	WB Wallpaper	P-7
MKG0231	WB 2' Header	P-8
MKG0232	Bargman Wallpaper	P-7
MKG0233	Bargman 2' Header	P-8
MKG0234	Bargman 4' Header	P-8
MKG0235	WB 4' Header	P-8
MKG0236	ROLA® Accessories Merchandising Display Header Sign - Large for #37-5364	P-8
MKG0237	Accessories Merchandising Display Header Sign - Small for #37-6474	P-8
MKG0238	ROLA® Banner 21" x 72"	P-9
MKG0239	ROLA® Adventure System & Roof Top Vortex Cargo Basket Sign for #37-6298	P-5, P-8
MKG0240	ROLA® Adventure System & Pursuit™ Sign for #37-6298	P-5, P-8
MKG0241	Banner, 6 ft. x 3 ft. "Trailer Hitches Professionally Installed Here" (English)	P-9

PART NO.	DESCRIPTION	PAGE #
MKG0242	HH Show Bags	P-11
MKG0243	Hidden Hitch & Tow Ready Accessories Merchandising Display Header Sign - Large for #37-5365 & #37-5366	P-8
MKG0244	Accessories Merchandising Display Header Sign - Small for #37-6474	P-8
MKG0245	Hidden Hitch Sign for #37-2103	P-3, P-8
MKG0246	Header Card for Hitch Display Stand #37-0031, 12" x 42"	P-8
MKG0247	Window Sticker, 2-Sided 6" x 8" (French)	P-10
MKG0248	Banner, 6 ft. x 3 ft. "Trailer Hitches Professionally Installed Here" (French)	P-9
MKG0249	Hidden Hitch® Flip Chart for Hitch Display Rack #37-0030	P-2
MKG0250	Window Sticker, 2-Sided 6" x 8" (English) "We Install Quality Trailer Hitches & Towing Accessories"	P-10
MKG0251	Single Pocket Literature Holder	P-11
MKG0252	Hours of Operation Sign	P-11
MKG0253	Pro Series™ Merchandising Sign	P-8
MKG0254	ROLA® Header Card for Display #37-6475	P-5, P-8
MKG0255	RS Elite Sign	P-3
MKG0257	RS/TEK/BD Counter Mat - Most Powerful Brands	P-9
MKG0258	Pro Series™ Merchandising Sign (French)	P-8
MKG0262	Out of Stock Tag	P-9
MKG0269	Out of Stock Tag	P-9
MKG0271	Out of Stock Tag	P-9
MKG0289	Out of Stock Tag	P-9
MKG0346	Reese Sign for #37-2103	P-3, P-8
MKG0535	General Product Catalog - Clip Art Disc	P-12
MKG0536	General Product Application/Technical Catalog - Clip Art Disc	P-12
OML 0127	Outboard Motor Lock	L-6
P20520-00	Mounting Bracket for Snap Ring Mount, 3/8" Pin	J-27
P9012-00	Mounting Bracket-1/2" Pin w/Lip	J-35
P9086-00	Retaining Ring for Snap Ring Mount Jacks	J-28, J-35
P9222-00	Mounting Bracket for Snap Ring Mount, 1/2" Pin	J-8, J-27
PL4 0201	Pin/Lanyard-5/16" w/4 Link Chain & Tab	J-39
PQM19-00	Weld-On Male Mount, 5/8" Pin - fits 2.5" Square Mount	J-8
RV20000103	2000 lbs., SW, A-Frame, 14" Travel, Black	J-9
RV20000303	2000 lbs., SW, A-Frame, 14" Travel, Black	J-9
SJ1 0300	Stabilizer, 2" Sq. x 13"L, Raw	J-36
SJ2 0324	Stabilizer, 1.75" Sq. x 28.75", Adjusts from 25" to 37"	J-36
SJ4 0324	Stabilizer, 1.75" Sq. x 20", Adjusts from 18" to 28"	J-36
SJL8 0300	Stabilizer, 1.5" Square, Adjusts from 8" to 27"	J-36
SJW 0324	Stabilizer, 1.75" x 30.5"- Yellow Zinc	J-36
SPB50 0300	Bottom Support Plate w/2.29" Dia. Hole	J-25
SPBQ500300	Bottom Support Plate w/2.3" Dia. Square Hole	J-25
ST400	Sidewinder Turret w/Hardware	F-9/10
ST400-5AS02	Fifth Airborne Sidewinder Combo	F-8
ST400-5AS16K	Fifth Airborne Sidewinder Combo	F-7
ST400-SW16K	Sidewinder Combo, Turret w/Hardware & Arm w/King Pin #ST400	F-10
ST400-SW19K	Sidewinder Combo, Turret w/Hardware & Arm w/King Pin #ST400	F-9
ST500	Sidewinder Turret w/Hardware	F-9/10
ST500-SW16K	Sidewinder Combo, Turret w/Hardware & Arm w/King Pin #ST500	F-10
ST500-SW19K	Sidewinder Combo, Turret w/Hardware & Arm w/King Pin #ST500	F-9
STC1000101	Spare Tire Carrier, Bolt-On	M-27
STC1000301	Spare Tire Carrier, Bolt-On	M-27
STL 0603	Spare Tire Lock	L-6, M-27
SW16K	Sidewinder 16K	F-10
SW19K	Sidewinder 19K	F-9
SWW-01	Sidewinder Wedge Kit, Elite™ Series	F-10
SWW-03	Sidewinder Wedge Kit, Select Series	F-10
SWW-04	Sidewinder Wedge Kit, Husky	F-10
SWW-05	Sidewinder Wedge Kit, Hi - Jacker	F-10
SWW-06	Sidewinder Wedge Kit, B&W	F-10
SWW-07	Sidewinder Wedge Kit, RBW	F-10

NUMERICALS

PART NO.	DESCRIPTION	PAGE #
SWW-08	Sidewinder Wedge Kit, Colibert	F-10
SWW-09	Sidewinder Wedge Kit, Pullrite	F-10
T1100 0101	Winch, 1100 lbs., Single-Speed	J-56
T1100 0301	Winch, 1100 lbs., 2-Speed	J-56
T1100Z0101	Winch, 1100 lbs., Single-Speed w/20' Strap	J-56
T1300 0101	Winch, 1300 lbs., Single-Speed	J-56
T1300 0301	Winch, 1300 lbs., 2-Speed	J-56
T1300Z0101	Winch, 1300 lbs., Single-Speed w/20' Strap	J-56
T1500 0101	Winch, 1500 lbs., Single-Speed	J-56
T1500 0301	Winch, 1500 lbs., 2-Speed	J-56
T1500Z0101	Winch, 1500 lbs., Single-Speed w/20' Strap	J-56
T1500Z0301	Winch, 1500 lbs., Single-Speed w/20' Strap	J-56
T1602 0101	Winch, 1600 lbs., Single-Speed	J-56
T1602 0301	Winch, 1600 lbs., 2-Speed	J-56
T1801 0101	Winch, 1800 lbs., Single-Speed	J-56
T1801 0301	Winch, 1800 lbs., 2-Speed	J-56
T1801Z0101	Winch, 1800 lbs., Single-Speed w/20' Strap	J-56
T1801Z0301	Winch, 1800 lbs., Single-Speed w/20' Strap	J-56
T2005 0101	Winch, 2000 lbs., 2-Speed	J-58
T2005 0301	Winch, 2000 lbs., 2-Speed	J-58
T2005S0301	Winch, 2000 lbs., 2-Speed, Special Drum	J-58
T2005Z0101	Winch, 2000 lbs., 2-Speed w/20' Strap	J-58
T2005Z0301	Winch, 2000 lbs., 2-Speed w/20' Strap	J-58
T2025 0301	Winch, 2000 lbs., 2-Speed, 1.75" Hub	J-58
T2100 0301	Winch, 2100 lbs., Single-Speed	J-56
T2605 0101	Winch, 2600 lbs., 2-Speed	J-58
T2605 0301	Winch, 2600 lbs., 2-Speed	J-58
T2605B0101	Winch, 2600 lbs., 2-Speed w/Brake	J-58
T2605B0301	Winch, 2600 lbs., 2-Speed w/Brake	J-58
T2605S0301	Winch, 2600 lbs., 2-Speed w/Special Drum	J-58
T2605Z0101	Winch, 2600 lbs., 2-Speed w/20' Strap	J-58
T2605Z0301	Winch, 2600 lbs., 2-Speed w/20' Strap	J-58
T2625 0101	Winch, 2600 lbs., 2-Speed, 1.75" Hub	J-58
T2625 0301	Winch, 2600 lbs., 2-Speed, 1.75" Hub	J-58
T3205 0101	Winch, 3200 lbs., 2-Speed	J-58
T3205 0301	Winch, 3200 lbs., 2-Speed	J-58
T3205B0101	Winch, 3200 lbs., 2-Speed w/Brake	J-58
T32ZHD0301	Winch, 3200 lbs., 2-Speed w/Heavy Duty 20' Strap	J-58
T3700 0101	Winch, 3700 lbs., 2-Speed	J-58
T3700 0301	Winch, 3700 lbs., 2-Speed	J-58
T600 0101	Winch, 600 lbs., Single-Speed	J-56
T600 0301	Winch, 600 lbs., Single-Speed	J-56
T600Z0301	Winch, 600 lbs., Single-Speed w/15' Strap	J-56
T900 0101	Winch, 900 lbs., Single-Speed	J-56
T900 0301	Winch, 900 lbs., Single-Speed	J-56
T900Z0101	Winch, 900 lbs., Single-Speed w/15' Strap	J-56
T900Z0301	Winch, 900 lbs., Single-Speed w/15' Strap	J-56
T903Z 0101	Winch, 900 lbs., Single-Speed for Personal Watercraft, w/12' Strap	J-56
T903Z 0301	Winch, 900 lbs. 2-WAY RATCHET W/STRAP	J-56
TJ12000101	Swivel Jack, 1200 lbs., Bolt-On, 6" Wheel	J-34
TJ12000301	Swivel Jack, 1200 lbs., Bolt-On, 6" Wheel	J-34
TJ120W0301	Swivel Jack, 1200 lbs., Weld-On, 6" Wheel	J-34
TJ12220301	JACK-1200 lbs. FIXED MOUNT-	J-35
TK100 0100	Trailer Keeper Lock	B-18, L-2
TL002	Toylok Adapter, King Pin Mount for #TL1020	L-5
TL005	Toylok Adapter, 1-1/4" Sq. and 2" Sq. Receiver Mounting Kit for #TL1020, #TL2021	L-5
TL006	Toylok Adapter, Stake Pocket Mount for #TL1020, #TL2021	L-5
TL007	Toylok Adapter, Trailer Frame Mount for #TL1020, #TL2021	L-5
TL008	Toylok Adapter, RV Bumper Mount for #TL1020, #TL2021	L-5
TL009	Toylok Adapter, ATV & UTV Mount for #TL1020, #TL2021	L-5
TL010	Toylok Adapter, Toolbox Mount for #TL1020, #TL2021	L-5
TL1020	Toylok, 18' Cable	L-5

PART NO.	DESCRIPTION	PAGE #
TL2021	Toylok, 15' Cable w/Lock	L-5
TP20A1534	Trailer Protector 2"-Lock-SPL.	B-20, L-4
WB100 0700	Wheel Bearing Kit, 1"	M-20
WB106 0700	Wheel Bearing Kit, 1-1/16"	M-20
WB138T0700	Wheel Bearing Kit w/ Dust Cover, 1-3/8" & 1-1/16"	M-20
WC325 0100	3/16" x 25' Cable w/Hook	J-62
WC750 0100	7/32" x 50' Cable w/Hook	J-62
WS20 0200	Winch Strap w/Hook, 2" x 20'	J-62
WS20 0700	Winch Strap w/Hook, 2" x 20'	J-62
WS20DP0200	Replacement Part, Winch Strap w/Hook, 2" x 20'	J-62
WS20HD0200	Winch Strap w/Hook, 2" x 20', Heavy Duty	J-62
WS20HD0600	Winch Strap w/Hook, 2" x 20', Heavy Duty	J-62
WSP12 0100	Winch Strap w/Hook & Loop, 2" X 12'	J-62
WSP12 0200	Winch Strap w/Hook & Loop, 2" X 12'	J-62
WSP12D0200	Winch Strap w/Hook & Loop, 2" x 12', Counter Display (12/ Straps per Display)	J-62
XLT14ZB101	Winch, 1400 lbs., Single-Speed w/20' Strap, Black Cover	J-56
XLT14ZB301	Winch, 1400 lbs., Single-Speed w/20' Strap, Black Cover	J-56
XLT18ZB101	Winch, 1800 lbs., Single-Speed w/20' Strap, Black Cover	J-56
XLT18ZB301	Winch, 1800 lbs., Single-Speed w/20' Strap, Black Cover	J-56
XLT20ZB301	Winch, 2000 lbs., 2-Speed w/20' Strap, Black Cover	J-58
XLT26ZB301	Winch, 2600 lbs., 2-Speed w/20' Strap, Black Cover	J-58
XLT32ZB301	Winch, 3200 lbs., 2-Speed w/Heavy Duty 20' Strap, Black Cover	J-58
XP10 0101	Jack, 1000 lbs. Bolt-Thru Swivel Mount Sidewind w/6" Wheel	J-34
XP10 0301	Jack, 1200 lbs., Swing-Away, Bolt-On, Steel Construction, 10" Travel, 6" Poly Wheel	J-34
XP100W0301	Jack, 1200 lbs., Bolt-On Weld-On	J-34
XP10W 0301	Jack, 1200 lbs., Swing-Away, Weld-On, Steel Construction, 10" Travel, 6" Poly Wheel, (Mounting Bracket Sold Separately)	J-34
XP10WC0301	Jack, 1200 lbs., Bolt-On 10" Weld-On	J-34
XP15 0101	Jack, 1500 lbs., Swing-Away, Bolt-On, Steel Construction, 10" Travel, 8" Poly Wheel	J-34
XP15 0301	Jack, 1500 lbs., Swing-Away, Bolt-On, Steel Construction, 10" Travel, 8" Poly Wheel	J-34
XP15L 0101	Jack, 1500 lbs., Swing-Away, Bolt-On, Steel Construction, 12" Travel, 8" Poly Wheel	J-34
XP15L 0301	Jack, 1500 lbs., Swing-Away, Bolt-On, Steel Construction, 12" Travel, 8" Poly Wheel	J-34
XP15W 0301	Jack, 1500 lbs., Swing-Away, Weld-On, Steel Construction, 10" Travel, 8" Poly Wheel (Need #P9012-00, Sold Separately)	J-34
XP15WC0301	Jack, 1500 lbs., Bolt-On, Independent Caster	J-34
XPD15L0101	Jack, 1500 lbs., Swing-Away, Bolt-On, Steel Construction, 12" Travel, 6" Dual Wheel	J-34
XPD15L0301	Jack, 1500 lbs., Swing-Away, Bolt-On, Steel Construction, 12" Travel, 6" Dual Wheel	J-34

