

AT9000 Advanced Transmitter

Differential Pressure Transmitters

OVERVIEW

AT9000 Advanced Transmitter is a microprocessor-based smart transmitter that features high performance and excellent stability. Capable of measuring gas, liquid, vapor, and liquid levels, it transmits 4 to 20 mA DC analog and digital signals according to the measured differential pressure.

It can also execute two-way communications between the CommPad (Handy Communicator) or HART[®] 375 communicator, thus facilitating self-diagnosis, range resetting, and automatic zero adjustment.



FEATURES

High performance and stability

- Unique characterization and composite semiconductor sensors realize high accuracy up to 0.04% F.S.
- Our proven sensor technology enables Long-term stability up to 0.1% of URL per 10-year.

Wide measuring range (range ability)

- A wide measuring range is available from a single model. This feature is highly effective in taking measurement over a wide range and reducing the need for inventory.
- Model GTX30D/31D/32D: 0.5 to 100 kPa (range ability: 200 to 1)

A diverse lineup

- A wide range of models is available to meet user requirements. They include draft range differential pressure, standard differential pressure, high differential pressure, standard differential pressure/high static pressure, and high differential pressure/high static pressure models.

- A wide variety of corrosion-resistant materials for wetted parts is also available.

Remote communication

- Two-way communication using digital output facilitates self-diagnosis, range resetting, automatic zero adjustment, and other operations.
- HART[®] protocol communication is available. (Option)

China RoHS

This device is used in the Oil & Gas, Petrochemical, Chemical, Pulp & Paper, Food & Beverage, Machinery, Steel/Metal & Mining, and Automobile industries and therefore does not fall under the China RoHS Legislation.

If this device is used in semiconductor manufacturing equipment, labeling on the device and documents for the China RoHS may be required. If such documents are required, consult a Yamatake representative.

HART[®] is a registered trademark of the HART Communication Foundation.

FUNCTIONAL SPECIFICATIONS**Type of protection**

NEMA3 and 4X
IEC IP67

FM Explosionproof and Dust Approvals

Explosionproof for Class I, Division 1, Groups A, B, C and D; Class I, Zone 1, AEx d IIC
Dust-Ignitionproof for Class II, III, Division 1, Groups E, F and G
T5 $-40^{\circ}\text{C} \leq \text{Tamb} \leq +85^{\circ}\text{C}$
Hazardous locations
Indoor / Outdoor Type 4X, IP67
Factory sealed, conduit seal not required for Division applications
Caution - Use supply wires suitable for 5°C above surrounding ambient

FM Intrinsically safe Approval

IS/I,II,III/1/ABCDEFGH/T4; $-40^{\circ}\text{C} \leq \text{Tamb} \leq +60^{\circ}\text{C}$;
80395278, 80395279,80395280; Entity; TYPE 4X; IP67
I/O/ AEx ia/IIC/T4; $-40^{\circ}\text{C} \leq \text{Tamb} \leq +60^{\circ}\text{C}$;80395278,
80395279, 80395280; Entity; TYPE 4X;IP67
Entity Parameters: $V_{\text{max}}(U_i)=30$ Volts, $I_{\text{max}}(I_i)=100\text{mA}$,
 $P_i=1\text{W}$, $C_i=10\text{nF}$, $L_i=0.5\text{mH}$

FM Nonincendive Approval

NI/I/2/ABCD/T4; $-40^{\circ}\text{C} \leq \text{Tamb} \leq +60^{\circ}\text{C}$;80395494;
NIFW; TYPE 4X; IP67
NI/I/2/IIC/T4; $-40^{\circ}\text{C} \leq \text{Tamb} \leq +60^{\circ}\text{C}$; 80395494;
NIFW; TYPE 4X; IP67
S/II,III/1/EFH/T4; $-40^{\circ}\text{C} \leq \text{Tamb} \leq +60^{\circ}\text{C}$;
80395494;NIFW; TYPE 4X; P67
Nonincendive Field Wiring Parameters: $V_{\text{max}}(U_i)=30$
Volts, $C_i=10\text{nF}$, $L_i=0.5\text{mH}$

ATEX Flameproof and Dust Certifications

 0344  KEMA 08ATEX0004

II 1/2 G Ex d IIC T6 Tprocess= 85°C
 $-30^{\circ}\text{C} \leq \text{Tamb} \leq +75^{\circ}\text{C}$ IP66/67
II 1/2 G Ex d IIC T5 Tprocess= 100°C
 $-30^{\circ}\text{C} \leq \text{Tamb} \leq +80^{\circ}\text{C}$ IP66/67
II 1/2 G Ex d IIC T4 Tprocess= 110°C
 $-30^{\circ}\text{C} \leq \text{Tamb} \leq +80^{\circ}\text{C}$ IP66/67
II 2 D Ex tD A21 IP66/67 T85 Tprocess= 85°C
 $-30^{\circ}\text{C} \leq \text{Tamb} \leq +75^{\circ}\text{C}$
II 2 D Ex tD A21 IP66/67 T100 Tprocess= 100°C
 $-30^{\circ}\text{C} \leq \text{Tamb} \leq +75^{\circ}\text{C}$
II 2 D Ex tD A21 IP66/67 T110 Tprocess= 110°C
 $-30^{\circ}\text{C} \leq \text{Tamb} \leq +75^{\circ}\text{C}$

Caution - Use supply wires suitable for 5°C above surrounding ambient

ATEX Intrinsic safety and Dust Certifications

 0344  KEMA 07ATEX0200 X

II 1 G Ex ia IIC T4 TPROCESS = 105°C
 $-30^{\circ}\text{C} \leq \text{Tamb} \leq +60^{\circ}\text{C}$ IP66 / 67
ELECTRICAL PARAMETERS: $U_i = 30$ V, $I_i = 93$ mA,
 $P_i = 1$ W, $C_i = 5$ nF, $L_i = 0.5$ mH
II 1 D Ex iaD 20 IP66 / 67 T105 TPROCESS = 105°C
 $-30^{\circ}\text{C} \leq \text{Tamb} \leq +60^{\circ}\text{C}$

ATEX Type n and Dust Certifications

 0344  KEMA 07ATEX0200 X

II 3 G Ex nL IIC T4 TPROCESS = 105°C
 $-30^{\circ}\text{C} \leq \text{Tamb} \leq +60^{\circ}\text{C}$ IP66 / 67
ELECTRICAL PARAMETERS: $U_i = 30$ V, $C_i = 5$ nF, $L_i = 0.5$ mH
II 2 D Ex tD A21 IP66 / 67 T85 TPROCESS = 85°C
 $-30^{\circ}\text{C} \leq \text{Tamb} \leq +75^{\circ}\text{C}$
II 2 D Ex tD A21 IP66 / 67 T100 TPROCESS = 100°C
 $-30^{\circ}\text{C} \leq \text{Tamb} \leq +80^{\circ}\text{C}$
II 2 D Ex tD A21 IP66 / 67 T110 TPROCESS = 110°C
 $-30^{\circ}\text{C} \leq \text{Tamb} \leq +80^{\circ}\text{C}$

NEPSI Flameproof and Dust Certifications

Ex d IIC T6 DIP A21 T_A 85°C Tprocess= 80°C $-40^{\circ}\text{C} \leq \text{Tamb} \leq +75^{\circ}\text{C}$
Ex d IIC T5 DIP A21 T_A 100°C Tprocess= 95°C $-40^{\circ}\text{C} \leq \text{Tamb} \leq +80^{\circ}\text{C}$
Ex d IIC T4 DIP A21 T_A 115°C Tprocess= 110°C $-40^{\circ}\text{C} \leq \text{Tamb} \leq +80^{\circ}\text{C}$
ENCLOSURE TYPE IP66/67
Certificate No. GYJ071268

NEPSI Intrinsic Safety Certification

Ex ia IIC T4 Tprocess= 105°C $-40^{\circ}\text{C} \leq \text{Tamb} \leq +60^{\circ}\text{C}$
Enclosure IP66 / 67
Electrical Parameters: $U_i=30\text{V}$, $I_i=100\text{mA}$, $P_i=1\text{W}$,
 $C_i=13\text{nF}$, $L_i=0.5\text{mH}$
Certificate No. GYJ071269

NEPSI Type n Certification

Ex nL IIC T4 Tprocess= 110°C $-40^{\circ}\text{C} \leq \text{Tamb} \leq +60^{\circ}\text{C}$
Enclosure IP66 / 67
Electrical Parameters: $U_i=30\text{V}$, $I_i=100\text{mA}$, $P_i=1\text{W}$,
 $C_i=13\text{nF}$, $L_i=0.5\text{mH}$
Certificate No. GYJ071269

IECEx Flameproof and Dust Certifications

Certificate No. IECEx KEM 08.0001
Ga/Gb Ex d IIC T6 Tprocess= 85°C $-30^{\circ}\text{C} \leq \text{Tamb} \leq +75^{\circ}\text{C}$ IP66/67
Ga/Gb Ex d IIC T5 Tprocess= 100°C $-30^{\circ}\text{C} \leq \text{Tamb} \leq +80^{\circ}\text{C}$ IP66/67
Ga/Gb Ex d IIC T4 Tprocess= 110°C $-30^{\circ}\text{C} \leq \text{Tamb} \leq +80^{\circ}\text{C}$ IP66/67
Ex tD A21 IP66/67 T85 Tprocess= 85°C $-30^{\circ}\text{C} \leq \text{Tamb} \leq +75^{\circ}\text{C}$
Ex tD A21 IP66/67 T100 Tprocess= 100°C $-30^{\circ}\text{C} \leq \text{Tamb} \leq +75^{\circ}\text{C}$
Ex tD A21 IP66/67 T110 Tprocess= 110°C $-30^{\circ}\text{C} \leq \text{Tamb} \leq +75^{\circ}\text{C}$
Caution - Use supply wires suitable for 5°C above surrounding ambient

IECEx Intrinsic safety and Dust Certifications

IECEx KEM 07.0058X
Zone 0 Ex ia IIC T4 TPROCESS = 105°C
 $-30^{\circ}\text{C} \leq \text{Tamb} \leq +60^{\circ}\text{C}$ IP66 / 67
ELECTRICAL PARAMETERS: $U_i = 30$ V, $I_i = 93$ mA,
 $P_i = 1$ W, $C_i = 5$ nF, $L_i = 0.5$ mH
Ex iaD 20 IP66 / 67 T105 TPROCESS = 105°C
 $-30^{\circ}\text{C} \leq \text{Tamb} \leq +60^{\circ}\text{C}$

IECEx Type n and Dust Certifications

IECEx KEM 07.0058X
Ex nL IIC T4 TPROCESS = 105°C
 $-30^{\circ}\text{C} \leq \text{Tamb} \leq +60^{\circ}\text{C}$ IP66 / 67

ELECTRICAL PARAMETERS: $U_i = 30 \text{ V}$, $C_i = 5 \text{ nF}$, $L_i = 0.5 \text{ mH}$

Ex tD A21 IP66 / 67 T85 TPROCESS = 85 °C

-30 °C ≤ Tamb ≤ +75 °C

Ex tD A21 IP66 / 67 T100 TPROCESS = 100 °C

-30 °C ≤ Tamb ≤ +80 °C

Ex tD A21 IP66 / 67 T110 TPROCESS = 110 °C

-30 °C ≤ Tamb ≤ +80 °C

EMC Conformity

89/336/EEC, 92/31/EEC, 93/68/EEC Electromagnetic Compatibility (EMC) Directive

Measuring span / Setting range / Working pressure range

Model	Measuring Span	Measuring range	Working Pressure Range
GTX 15D	0.1 to 2 kPa {10 to 200 mmH ₂ O}	-1 to 1 kPa {-100 to 100 mmH ₂ O}	-70 to 210 kPa {-0.7 to 2.1 kgf/cm ² }
GTX 30D	0.5 to 100 kPa {50 to 10160 mmH ₂ O}	-100 to 100 kPa {-10160 to 10160 mmH ₂ O}	2.0kPa abs to 3.5MPa {15 mmHg abs to 35 kgf/cm ² } *Note 1
GTX 31D	0.5 to 100 kPa {50 to 10160 mmH ₂ O}	-100 to 100 kPa {-10160 to 10160 mmH ₂ O}	2.0 kPa abs to 21 MPa {15 mmHg abs to 210 kgf/cm ² } *Note 1, *Note 2 (For vacuum pressure, see Figure 1, 2)
GTX 32D	0.5 to 100 kPa {50 to 10160 mmH ₂ O}	-100 to 100 kPa {-10160 to 10160 mmH ₂ O}	2.0 kPa abs to 42 MPa {15mmHg abs to 420 kgf/cm ² } *Note 3 (For vacuum pressure, see Figure 1, 2)
GTX 40D	35 to 700 kPa {0.35 to 7kgf/cm ² }	-100 to 700 kPa {-1 to 7kgf/cm ² }	2.0kPa abs to 3.5MPa {15 mmHg abs to 35 kgf/cm ² } *Note 1
GTX 41D	35 to 700 kPa {0.35 to 7kgf/cm ² }	-100 to 700 kPa {-1 to 7kgf/cm ² }	2.0 kPa abs to 21 MPa {15 mmHg abs to 210 kgf/cm ² } *Note 1, *Note 2 (For vacuum pressure, see Figure 1, 2)
GTX 42D	35 to 700 kPa {0.35 to 7kgf/cm ² }	-100 to 700 kPa {-1 to 7kgf/cm ² }	2.0 kPa abs to 42 MPa {15mmHg abs to 420 kgf/cm ² } *Note 3 (For vacuum pressure, see Figure 1, 2)
GTX 71D	0.25 to 14MPa {2.5 to 140kgf/cm ² }	-0.1 to 14 MPa {-1 to 140 kgf/cm ² }	2.0 kPa abs to 21 MPa {15 mmHg abs to 210 kgf/cm ² } *Note 1, *Note 2 (For vacuum pressure, see Figure 1, 2)
GTX 72D	0.25 to 14MPa {2.5 to 140kgf/cm ² }	-0.1 to 14 MPa {-1 to 140 kgf/cm ² }	2.0 kPa abs to 42 MPa {15mmHg abs to 420 kgf/cm ² } *Note 3 (For vacuum pressure, see Figure 1, 2)

- Note) 1) With PVC wetted parts, the maximum working pressure is 1.5 MPa {15 kgf/cm²}.
 2) With 304 SST bolts and nuts, the maximum working pressure is 10MPa {100 kgf/cm²}.
 3) With 304 SST bolts and nuts, the maximum working pressure is 23.3 MPa {233 kgf/cm²}.

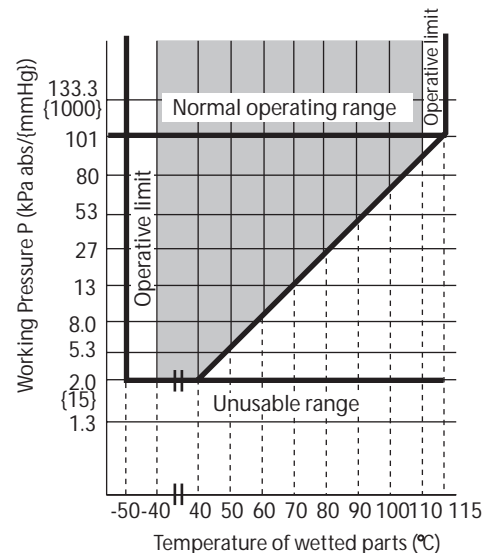

Figure 1 Working pressure and temperature of wetted parts section (for general purpose models)

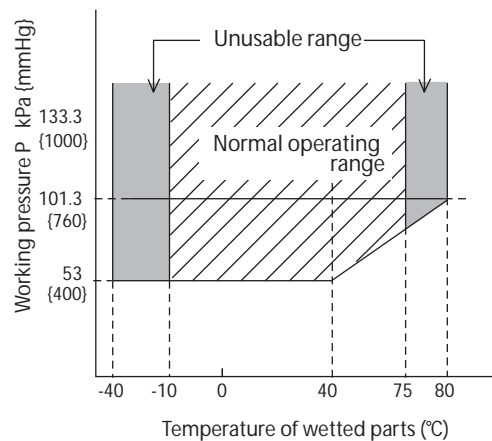

Figure 2 Working pressure and temperature of wetted parts section (for oxygen and chlorine service)

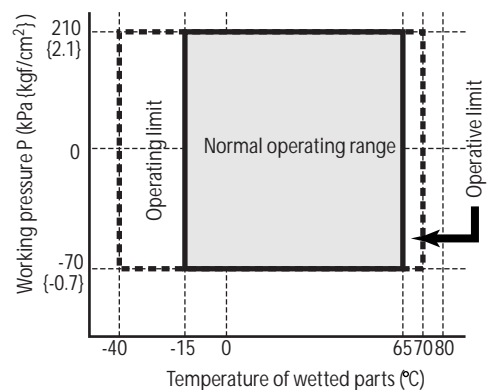

Figure 3 Working pressure and temperature of wetted parts section (for model GTX15D regular type)

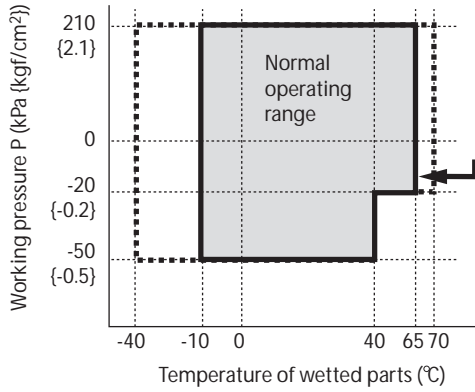

Figure 4 Working pressure and temperature of wetted parts section (for model GTX15D oxygen service)

Supply voltage and load resistance

17.9 to 42V DC. A load resistance of 250 Ω or more is necessary between loops. See Figure 5.

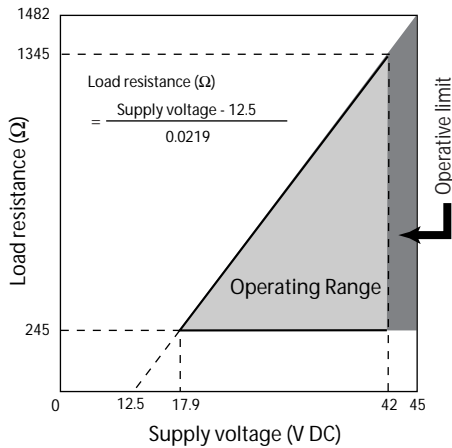

Figure 5 Supply voltage vs. load resistance characteristics

Note) For communication with HART communicator or Comm-Pad, a load resistance of 250 Ω or more is necessary.

Output

Analog output (4 to 20 mA DC) with DE protocol
 Analog output (4 to 20 mA DC) with HART protocol

Output signal

3.6 to 21.6 mA
 3.8 to 20.5 mA (NAMUR NE43 compliant)

Failure Alarm

Upper: 21.6 mA or more
 Lower: 3.6 mA or less

Ambient temperature limit

Normal operating range

- 40 to 85°C for general purpose models
- 15 to 65°C for general purpose model (model GTX15D)
- 15 to 85°C for general purpose model (model GTX32D/42D/72D)
- 10 to 75°C for oxygen and chlorine models

- 10 to 65°C for oxygen and chlorine model (model GTX15D)
- 25 to 80°C for model with digital indicators
- 15 to 65°C for model with digital indicators (model GTX15D)
- 15 to 80°C for model with digital indicators (model GTX132D/42D/72D)

Operative limits

- 50 to 93°C for general purpose models
- 40 to 70°C for general purpose model (model GTX15D)
- 25 to 93°C for general purpose model (model GTX32D/42D/72D)
- 40 to 80°C for oxygen and chlorine models
- 30 to 85°C for models with digital indicators
- 40 to 70°C for models with digital indicators (model GTX15D)
- 25 to 85°C for models with digital indicators (model GTX132D/42D/72D)

Transportation and storage conditions

- 50 to 85°C for general purpose models
- 15 to 65°C for general purpose model (model GTX15D)
- 15 to 85°C for general purpose model (model GTX32D/42D/72D)

Temperature ranges of wetted parts

Normal operating range

- 40 to 110°C for general purpose models
- 15 to 65°C for general purpose model (model GTX15D)
- 15 to 110°C for general purpose model (model GTX32D/42D/72D)
- 20 to 75°C for oxygen and chlorine models
- 15 to 65°C for oxygen and chlorine model (model GTX15D)
- 15 to 75°C for oxygen and chlorine model (model GTX32D/42D/72D)

Operative limits

- 50 to 115°C for general purpose models
- 40 to 70°C for general purpose model (model GTX15D)
- 20 to 115°C for general purpose model (model GTX32D/42D/72D)
- 40 to 80°C for oxygen and chlorine models
- 40 to 70°C for oxygen and chlorine models (model GTX15D)
- 20 to 80°C for oxygen and chlorine models (model GTX32D/42D/72D)

Ambient humidity limits

5 to 100% RH

Stability against supply voltage change

± 0.005% FS/V

Response time

Below 100 msec.(model GTX30D/31D, when damping time is set to 0 sec.)

Damping time

Selectable from 0 to 32 sec. in ten stages

Zero Stability

± 0.1% of URL per 10-year (model GTX30D/31D/32D/40D/41D/42D)

Lightning protection

Applicable Standards; IEC 61000-4-5
 Peak value of current surge(80/20μ sec.): 6000A

Indicator

The digital LCD indicator (optional) indicates engineering units and can be set freely between -99999 and 99999 (5 digits). For meter calibration, specify the following items when placing your order

- Meter calibration range
- Meter calibration unit
- Linear / Square-root for meter indication.

Various kinds of data can be set using the CommPad or the HART[®]375 communicator.

Bolts and nuts materials (for fastening meter body cover)

Carbon steel (SNB7), 304 SST, 630 SST

Paint**Standard**

Corrosion-resistant paint (Baked acrylic paint)

Corrosion-proof finish

Corrosion-proof paint (Baked epoxy paint), fungus-proof finish

Corrosion-resistant finish (silver paint)

Transmitter case is coated with silver paint in addition to the above corrosion-resistant finish.

OPTIONAL SPECIFICATIONS**Oil free finish**

The transmitter is shipped with oil-free wetted parts.

Adapters for anticorrosion materials

These are adaptor flanges to connect 82 mm pipes made of anticorrosion materials [excluding ASTM B575 (Equivalent to Hastelloy C-276)] to 54 mm general-purpose pipes.

External zero/span adjustment function

The transmitter can be easily zero/span adjusted in the field.

Elbow

This is an adaptor for changing the electrical conduit connection port from the horizontal to the vertical direction, if required by wiring conditions in the field. One or two elbows may be used as needed.

Conformance to Non SI units

We deliver transmitters set to any Non SI units as specified.

Safety Transmitter

Select this option to be used as a component of Safety Instrument System (SIS).

AT9000 is complied with IEC61508, certified according to Safety Integrity Level2 (SIL-2)

Alarm Output (contact output)

Contact output is prepared as alarm output when alarm (Output Alarm/Sensor Temp. Alarm) condition is

detected. It can be set to Normally Open. (When alarm is detected, Contact ON).

Custom calibration

Calibrate for the specified pressure range at the factory.

PHYSICAL SPECIFICATIONS**Materials****Fill fluid**

Silicone oil for general purpose models

Fluorine oil for oxygen and chlorine models

Center body

316 SST

Transmitter case

Aluminum alloy

Meter body cover flange

SCS14A (Equivalent to 316 SST) or 316 SST, PVC

For Wetted parts**Adapter flange (option)**

SCS14A (Equivalent to 316 SST), PVC

Center body

316 SST (Diaphragm 316L SST)

ASTM B575 (Equivalent to Hastelloy C-276), Tantalum, 316L SST

Vents and plugs

316 SST, PVC

Weight

Approx. 3.6 kg (model GTX30D)

INSTALLATION**Electrical connection**

1/2NPT internal thread, M20 internal thread.

Grounding

Resistance 100 Ω max.

Mounting

Can be installed on a 2-inch horizontal or vertical pipe (can be directly mounted on a process pipe)

Process connection

Rc1/2, 1/2NPT internal thread and Rc1/4, 1/4NPT internal thread.

 WARNING

- Impact to transmitter can damage sensor module.

Model GTX30D/31D (for oxygen / chlorine service)

(Material of wetted parts: Diaphragm; 316L SST, Others;316 SST)

Reference accuracy (*3)(*4)	Linear output: $\pm 0.075\%$ (For $\chi \geq 50.0kPa$ {5000mmH ₂ O}) $\pm 0.1\%$ (For $50.0kPa$ {5000mmH ₂ O} > $\chi \geq 5.0kPa$ {500 mmH ₂ O}) $\pm \left(0.025 + 0.075 \times \frac{5.0}{\chi}\right) \%$ (For $\chi < 5.0kPa$ {500 mmH ₂ O}) Square-root output: When output is 50 to 100%: same as the linear output When output is 7.1 to 50%: linear output $\times \frac{50}{\text{square-root} \cdot \text{output}} \%$ When output is less than 7.1%: dropout
Ambient Temperature effect (Shift from the set range) Change of 30°C (*3) (Range from -5 to 55°C)	Combined shift: (including zero and span shifts) $\pm 0.44\%$ (For $\chi \geq 12.5kPa$ {1250 mmH ₂ O}) $\pm \left(0.19 + 0.25 \times \frac{12.5}{\chi}\right) \%$ (For $\chi \leq 12.5kPa$ {1250 mmH ₂ O})
Static pressure effect (Shift with respect to Setting range) (*3) Change of 7 MPa {70 kgf/cm²}	Zero shift: $\pm \left(0.03 + 0.17 \times \frac{20}{\chi}\right) \%$ Combined shift: (including zero and span shifts) $\pm 0.4\%$ (For $\chi \geq 20.0kPa$ {2000 mmH ₂ O}) $\pm \left(0.03 + 0.37 \times \frac{20}{\chi}\right) \%$ (For $\chi < 20.0kPa$ {2000 mmH ₂ O})

Model GTX30D/31D

(Material of wetted parts: Diaphragm; ASTM B575 (Equivalent to Hastelloy C-276), Tantalum, 316L SST Others; ASTM B575 (Equivalent to Hastelloy C-276), Tantalum, 316L SST)

Reference accuracy (*3)(*4)	Linear output: $\pm 0.2\%$ (For $\chi \geq 10kPa$ {1000mmH ₂ O}) $\pm \left(0.125 + 0.075 \times \frac{10}{\chi}\right) \%$ (For $\chi \geq 10kPa$ {1000 mmH ₂ O}) Square-root output: When output is 50 to 100%: same as the linear output When output is 7.1 to 50%: linear output $\times \frac{50}{\text{square-root} \cdot \text{output}} \%$ When output is less than 7.1%: dropout
Ambient Temperature effect (Shift from the set range) Change of 30°C (*3) (Range from -5 to 55°C)	Combined shift: (including zero and span shifts) $\pm \left(0.55 + 0.65 \times \frac{20.0}{\chi}\right) \%$
Static pressure effect (Shift with respect to Setting range) (*3) Change of 7 MPa {70 kgf/cm²}	Zero shift: $\pm \left(0.03 + 0.62 \times \frac{20.0}{\chi}\right) \%$ Combined shift: (including zero and span shifts) $\pm \left(0.55 + 0.45 \times \frac{20.0}{\chi}\right) \%$ ($\chi \geq 20.0kPa$ {2000 mmH ₂ O}) $\pm \left(0.18 + 0.82 \times \frac{20.0}{\chi}\right) \%$ ($\chi < 20.0kPa$ {2000 mmH ₂ O})

*3: Within a range of URV ≥ 0 and LRV ≥ 0 .

*4: Reference accuracy at calibrated condition.

Model GTX32D

(Material of wetted parts: Diaphragm; 316L SST, Others;316 SST)

Reference accuracy (*4)	Linear output:	$\pm 0.075\%$ (For $\chi \geq 50.0kPa$ {5000mmH ₂ O}) $\pm 0.1\%$ (For $50.0kPa$ {5000mmH ₂ O} > $\chi \geq 5.0kPa$ {500 mmH ₂ O}) $\pm \left(0.025 + 0.075 \times \frac{5.0}{\chi}\right) \%$ (For $\chi < 5.0kPa$ {500 mmH ₂ O})
	Square-root output:	When output is 50 to 100%: same as the linear output When output is 7.1 to 50%: linear output $\times \frac{50}{\text{square-root} \cdot \text{output}} \%$ When output is less than 7.1%: dropout
Ambient Temperature effect (Shift from the set range) (*3) Change of 30°C	Combined shift: (including zero and span shifts)	$\pm 0.41\%$ (For $\chi \geq 12.5kPa$ {1250 mmH ₂ O}) $\pm \left(0.18 + 0.23 \times \frac{12.5}{\chi}\right) \%$ (For $\chi \leq 12.5kPa$ {1250 mmH ₂ O})
Static pressure effect (Shift with respect to Setting range) (*3) Change of 7 MPa {70 kgf/cm²}	Zero shift:	$\pm \left(0.03 + 0.17 \times \frac{20}{\chi}\right) \%$
	Combined shift: (including zero and span shifts)	$\pm 0.4\%$ (For $\chi \geq 20.0kPa$ {2000 mmH ₂ O}) $\pm \left(0.03 + 0.37 \times \frac{20}{\chi}\right) \%$ (For $\chi < 20.0kPa$ {2000 mmH ₂ O})

Model GTX40D/41D/42D

(Material of wetted parts: Diaphragm; 316L SST, Others; 316 SST)

Reference accuracy (*3)(*4)	Linear output:	$\pm 0.1\%$ (For $\chi \geq 140kPa$ {1.4 kgf/cm ² }) $\pm \left(0.025 + 0.075 \times \frac{140}{\chi}\right) \%$ (For $\chi < 140kPa$ {1.4 kgf/cm ² })
	Square-root output:	When output is 50 to 100%: same as the linear output When output is 7.1 to 50%: linear output $\times \frac{50}{\text{square-root} \cdot \text{output}} \%$ When output is less than 7.1%: dropout
Ambient Temperature effect (Shift from the set range) Change of 30°C (*3) (Range from -5 to 55°C)	Combined shift: (including zero and span shifts)	$\pm 0.41\%$ (For $\chi \geq 210kPa$ {2.1 kgf/cm ² }) $\pm \left(0.18 + 0.23 \times \frac{210}{\chi}\right) \%$ (For $\chi < 210kPa$ {2.1 kgf/cm ² })
Static pressure effect (Shift with respect to Setting range) (*3) Change of 7 MPa {70 kgf/cm²}	Zero shift:	$\pm \left(0.03 + 0.17 \times \frac{700}{\chi}\right) \%$
	Combined shift: (including zero and span shifts)	$\pm 0.33\%$ (For $\chi \geq 700kPa$ {7.1 kgf/cm ² }) $\pm \left(0.03 + 0.37 \times \frac{700}{\chi}\right) \%$ (For $\chi < 700kPa$ {7.1 kgf/cm ² })

*3: Within a range of URV ≥ 0 and LRV ≥ 0 .

*4: Reference accuracy at calibrated condition.

Model GTX40D/41D

(Material of wetted parts: Diaphragm; ASTM B575 (Equivalent to Hastelloy C-276), Tantalum, 316L SST Others; ASTM B575 (Equivalent to Hastelloy C-276), Tantalum, 316L SST)

Reference accuracy (*3)(*4)	Linear output:	$\pm 0.2\%(\chi \geq 140kPa \{1.4 \text{ kgf/cm}^2\})$ $\pm\left(0.125 + 0.075 \times \frac{140}{\chi}\right) \% \text{ (For } \chi < 140kPa \{1.4 \text{ kgf/cm}^2\})$
	Square-root output:	When output is 50 to 100%: same as the linear output When output is 7.1 to 50%: linear output $\times \frac{50}{\text{square-root} \cdot \text{output}} \%$ When output is less than 7.1%: dropout
Ambient Temperature effect (Shift from the set range) Change of 30°C (*3) (Range from -5 to 55°C)	Combined shift: (including zero and span shifts)	$\pm 1.20\%(\chi \geq 210kPa \{2.1 \text{ kgf/cm}^2\})$ $\pm\left(0.55 + 0.65 \times \frac{210}{\chi}\right) \% \text{ (For } \chi < 210kPa \{2.1 \text{ kgf/cm}^2\})$
Static pressure effect (Shift with respect to Setting range) (*3) Change of 7 MPa {70 kgf/cm²}	Zero shift:	$\pm\left(0.03 + 0.295 \times \frac{700}{\chi}\right) \%$
	Combined shift: (including zero and span shifts)	$\pm\left(0.08 + 0.495 \times \frac{700}{\chi}\right) \%$

Model GTX71D/72D

(Material of wetted parts: Diaphragm; 316L SST, Others; 316 SST)

Reference accuracy (*3)(*4)	Linear output:	$\pm 0.15\% \text{ (For } \chi \geq 3.5MPa \{35 \text{ kgf/cm}^2\})$ $\pm\left(0.1 + 0.05 \times \frac{3.5}{\chi}\right) \% \text{ (For } \chi < 3.5MPa \{35 \text{ kgf/cm}^2\})$
	Square-root output:	When output is 50 to 100%: same as the linear output When output is 7.1 to 50%: linear output $\times \frac{50}{\text{square-root} \cdot \text{output}} \%$ When output is less than 7.1%: dropout
Ambient Temperature effect (Shift from the set range) Change of 30°C (*3) (Range from -5 to 55°C)	Combined shift: (including zero and span shifts)	$\pm 0.41\% \text{ (For } \chi \geq 3.5MPa \{35 \text{ kgf/cm}^2\})$ $\pm\left(0.18 + 0.23 \times \frac{3.5}{\chi}\right) \% \text{ (For } \chi < 3.5MPa \{35 \text{ kgf/cm}^2\})$
Static pressure effect (Shift with respect to Setting range) (*3) Change of 7 MPa {70 kgf/cm²}	Zero shift:	$\pm\left(0.03 + 0.17 \times \frac{7}{\chi}\right) \%$
	Combined shift: (including zero and span shifts)	$\pm 0.4\% \text{ (For } \chi \geq 7MPa \{70 \text{ kgf/cm}^2\})$ $\pm\left(0.03 + 0.37 \times \frac{7}{\chi}\right) \% \text{ (For } \chi < 7MPa \{70 \text{ kgf/cm}^2\})$

Note) *3: Within a range of URV ≥ 0 and LRV ≥ 0 .

*4: Reference accuracy at calibrated condition.

Model GTX71D/72D

(Material of wetted parts: Diaphragm; 316L SST, Others; 316L SST)

Reference accuracy (*3)(*4)	Linear output: $\pm 0.2\%$ (For $\chi \geq 3.5MPa$ {35 kgf/cm ² }) $\pm \left(0.15 + 0.05 \times \frac{3.5}{\chi}\right) \%$ (For $\chi < 3.5MPa$ {35 kgf/cm ² }) Square-root output: When output is 50 to 100%: same as the linear output When output is 7.1 to 50%: linear output $\times \frac{50}{\text{square-root} \cdot \text{output}} \%$ When output is less than 7.1%: dropout
Ambient Temperature effect (Shift from the set range) Change of 30°C (*3) (Range from -5 to 55°C)	Combined shift: (including zero and span shifts) $\pm 1.20\%$ (For $\chi \geq 3.5MPa$ {35 kgf/cm ² }) $\pm \left(0.55 + 0.65 \times \frac{3.5}{\chi}\right) \%$ (For $\chi < 3.5MPa$ {35 kgf/cm ² })
Static pressure effect (Shift with respect to Setting range) (*3) Change of 7 MPa {70 kgf/cm²}	Zero shift: $\pm \left(0.03 + 0.295 \times \frac{7}{\chi}\right) \%$ Combined shift: (including zero and span shifts) $\pm \left(0.45 + 0.125 \times \frac{7}{\chi}\right) \%$ (For $\chi \geq 7MPa$ {70 kgf/cm ² }) $\pm \left(0.08 + 0.495 \times \frac{7}{\chi}\right) \%$ (For $\chi < 7MPa$ {70 kgf/cm ² })

Note) *3: Within a range of $URV \geq 0$ and $LRV \geq 0$.

*4: Reference accuracy at calibrated condition.

MODEL SELECTION

Model GTX15D(Standard type for lowest differential pressure)

Model No.:GTX_ _D-Selection I(I II III IV V VI VII)-Selection II(I II III IV V VI)-Option

Basic Model No.

Measuring span	0.1 to 2.0 kPa (10 to 200 mmH ₂ O)	GTX15D
----------------	---	--------

Selection I

I	Output	4 to 20mA (SFN Communication)	A
		4 to 20mA (HART Communication)	B
II	Fill fluid	Regular type (Silicone oil)	A
		For oxygen service (Fluorine oil)	H
III	Material (Meter body cover, Vent/ Drain plugs)	Meterbody cover	Vent / Drain plugs
		SCS14A	316 SST A
IV	Material (center body)	316 SST (Diaphragm:316L SST) A	
V	Process connections	Rc 1/2, with adapter flange	A
		Rc 1/4, with adapter flange	B
		Rc 1/4, without adapter flange	C
		1/2 NPT internal thread, with adapter flange	D
		1/4 NPT internal thread, with adapter flange	E
		1/4 NPT internal thread, without adapter flange	F
VI	Process installation	Vertical piping, top connection	A
		Vertical piping, bottom connection	B
		Horizontal piping, front connection	C
VII	Bolt/nut	304 SST B	

Selection II

I	Electrical connection	1/2 NPT, Watertight	-	A
		M20, Watertight *1		B
II	Explosion proof	None		XX
		FM Explosion proof		F1
		FM Intrinsically safe		F2
		FM Nonincendive		F5
		ATEX Explosion proof		A1
		ATEX Intrinsically safe		A2
		ATEX Type n		A5
		IECEX Explosion proof,		E1
		IECEX Intrinsically safe		E2
		IECEX Type n		E5
		NEPSI Explosionproof		N1
		NEPSI Intrinsically safe		N2
III	Indicator	None		X
		With indicator		A
IV	Paint	Standard		X
		Corrosion-proof		B
		Corrosion-resistant (Silver coating)		D
V	Failure alarm	Upper limit of output at abnormal condition		A
		Lower limit of output at abnormal condition		B
VI	Mounting bracket	None		X
		Carbon steel (L form)		3
		304 SST (L form)		4

Note) *1 Not applicable for the combination with code F1 "FM Explosion proof" of Explosion proof.

(Continued)

(Continued from previous page)

Model No.:GTX__D-Selection I(I II III IV V VI VII)-Selection II(I II III IV V VI)-Option

Option		
	No options	XX
	Adapter flange for corrosion-resistant application (316L SST or Tantalum for the wetted parts of centerbody)	A1
	With external Zero/Span adjustment *11	A2
	One elbow (left) *6*7*10	G1
	One elbow (right) *6*7*10	G2
	2 elbows *6*8*10	G3
	Long vent/drain plugs	G4
	Side vent/drain top *6	G6
	Side vent/drain bottom *6	G7
	Oil and water free finish	K1
	Oil free finish *4	K3
	Au Plating Diaphragm	L1
	Safety Transmitter *5	Q1
	NAMUR NE43 Compliant Output Signal Limits:3.8 to 20.5mA (Output 21.6mA/selected upper limit, 3.6mA/selected lower limit)	Q2
	Alarm Output (contact output)	Q7
	Custom calibration	R1
	Test report	T1
	Mill certificate	T2
	Traceability certificate	T4
	NACE certificate *9	T5
	Non SI Unit	W1

- Note) *4 No need to select when Fill Fluid code H, or J is selected.
 *5 Not applicable for the combination with code A2, or Q7 of Option.
 *6 Not applicable for the combination with code A, or B of Process installation.
 *7 Not applicable for the combination with code F1 "FM Explosion proof" of Explosion proof.
 *8 Not applicable for any Explosion proof. Please select code XX "None" of Explosion proof.
 *9 Applicable for "ASTM B575", code B of Material (center body).
 *10 Not applicable for the combination with code B "M20, Watertight" electrical connection.
 *11 Not applicable for the combination with code X "None" of Indicator. Please select "With indicator".

Model GTX30D(Standard type for standard differential pressure)

Model GTX40D(Standard type for high differential pressure)

Model No.:GTX__D-Selection I(I II III IV V VI VII)-Selection II(I II III IV V VI)-Option

Basic Model No.

	Measuring span	0.5 to 100kPa (50 to 10160mmH ₂ O)	GTX30D
		35 to 700kPa (0.35 to 7kgf/cm ²)	GTX40D

Selection I

I	Output	4 to 20mA (SFN Communication)	A
		4 to 20mA (HART Communication)	B
II	Fill fluid	Regular type (Silicone oil)	A
		For oxygen service (Fluorine oil)	H
III	Material (Meter body cover, Vent/ Drain plugs)	Meterbody cover	Vent / Drain plugs
		SCS14A	
IV	Material (center body)	316 SST (Diaphragm:316L SST)	A
		ASTM B575 (Equivalent to Hastelloy C-276)	B
V	Process connections	Rc 1/2, with adapter flange	A
		Rc 1/4, with adapter flange	B
		Rc 1/4, without adapter flange	C
		1/2 NPT internal thread, with adapter flange	D
		1/4 NPT internal thread, with adapter flange	E
		1/4 NPT internal thread, without adapter flange	F
VI	Process installation	Vertical piping, top connection	A
		Vertical piping, bottom connection	B
		Horizontal piping, front connection	C
VII	Bolt/nut	304 SST	B

Selection II

			-	
I	Electrical connection	1/2 NPT, Watertight	A	
		M20, Watertight *3	B	
II	Explosion proof	None		XX
		FM Explosion proof		F1
		FM Intrinsically safe		F2
		FM Nonincendive		F5
		ATEX Explosion proof		A1
		ATEX Intrinsically safe		A2
		ATEX Type n		A5
		IECEX Explosion proof,		E1
		IECEX Intrinsically safe		E2
		IECEX Type n		E5
		NEPSI Explosionproof		N1
		NEPSI Intrinsically safe		N2
		NEPSI Type n		N5
III	Indicator	None		X
		With indicator		A
IV	Paint	Standard		X
		Corrosion-proof		B
		Corrosion-resistant (Silver coating)		D
V	Failure alarm	Upper limit of output at abnormal condition		A
		Lower limit of output at abnormal condition		B
VI	Mounting bracket	None		X
		Carbon steel (L form)		3
		304 SST (L form)		4

Note) *3 Not applicable for the combination with code F1 "FM Explosion proof" of Explosion proof.

(Continued)

(Continued from previous page)

Model No.:GTX__D-Selection I (I II III IV V VI VII) - Selection II(I II III IV V VI) - **Option**

Option		
	No options	XX
	Adapter flange for corrosion-resistant application (316L SST or Tantalum for the wetted parts of centerbody)	A1
	With external Zero/Span adjustment *11	A2
	One elbow (left) *6*7*10	G1
	One elbow (right) *6*7*10	G2
	2 elbows *6*8*10	G3
	Long vent/drain plugs	G4
	Side vent/drain top *6	G6
	Side vent/drain bottom *6	G7
	Oil and water free finish	K1
	Oil free finish *4	K3
	Au Plating Diaphragm	L1
	Safety Transmitter *5	Q1
	NAMUR NE43 Compliant Output Signal Limits:3.8 to 20.5mA (Output 21.6mA/selected upper limit, 3.6mA/selected lower limit)	Q2
	Alarm Output (contact output)	Q7
	Custom calibration	R1
	Test report	T1
	Mill certificate	T2
	Traceability certificate	T4
	NACE certificate *9	T5
	Non SI Unit	W1

- Note) *4 No need to select when Fill Fluid code H, or J is selected.
 *5 Not applicable for the combination with code A2, or Q7 of Option.
 *6 Not applicable for the combination with code A, or B of Process installation.
 *7 Not applicable for the combination with code F1 "FM Explosion proof" of Explosion proof.
 *8 Not applicable for any Explosion proof. Please select code XX "None" of Explosion proof.
 *9 Applicable for "ASTM B575", code B of Material (center body).
 *10 Not applicable for the combination with code B "M20, Watertight" electrical connection.
 *11 Not applicable for the combination with code X "None" of Indicator. Please select "With indicator".

Model GTX31D(High static pressure type for standard differential pressure)

Model GTX41D(High static pressure type for high differential pressure)

Model GTX71D(High static pressure type for highest differential pressure)

Model No.:GTX_ _D-Selection I(I II III IV V VI VII)-Selection II(I II III IV V VI)-Option

Basic Model No.

	Measuring span	0.5 to 100kPa (50 to 10160mmH ₂ O)	GTX31D
		35 to 700kPa (0.35 to 7kgf/cm ²)	GTX41D
		0.25 to 14MPa (2.5 to 140kgf/cm ²)	GTX71D

Selection I

I	Output	4 to 20mA (SFN Communication)	A	
		4 to 20mA (HART Communication)	B	
II	Fill fluid	Regular type (Silicone oil)	A	
		For oxygen service (Fluorine oil)	H	
		For chlorine service (Fluorine oil) *7	J	
III	Material (Meter body cover, Vent/ Drain plugs)	Meterbody cover	Vent / Drain plugs	
		SCS14A	316 SST	A
		PVC *4*9	PVC *4*9*10*11	C
IV	Material (center body)	316 SST (Diaphragm:316L SST)	A	
		ASTM B575 (Equivalent to Hastelloy C-276) *8*13	B	
		Tantalum *1*6	C	
		316L SST *1*6	D	
V	Process connections	Rc 1/2, with adapter flange *10	A	
		Rc 1/4, with adapter flange	B	
		Rc 1/4, without adapter flange	C	
		1/2 NPT internal thread, with adapter flange *10	D	
		1/4 NPT internal thread, with adapter flange	E	
		1/4 NPT internal thread, without adapter flange	F	
VI	Process installation	Vertical piping, top connection *6*11	A	
		Vertical piping, bottom connection *6*11	B	
		Horizontal piping, front connection	C	
VII	Bolt/nut	Carbon steel	A	
		304 SST *5	B	
		630 SST	C	

Selection II

I	Electrical connection	1/2 NPT, Watertight	A
		M20, Watertight *12	B
II	Explosion proof	None	XX
		FM Explosion proof	F1
		FM Intrinsically safe	F2
		FM Nonincendive	F5
		ATEX Explosion proof	A1
		ATEX Intrinsically safe	A2
		ATEX Type n	A5
		IECEX Explosion proof,	E1
		IECEX Intrinsically safe	E2
		IECEX Type n	E5
		NEPSI Explosionproof	N1
		NEPSI Intrinsically safe	N2
		NEPSI Type n	N5
III	Indicator	None	X
		With indicator	A
IV	Paint	Standard	X
		Corrosion-proof	B
		Corrosion-resistant (Silver coating)	D
V	Failure alarm	Upper limit of output at abnormal condition	A
		Lower limit of output at abnormal condition	B
VI	Mounting bracket	None	X
		Carbon steel (L form) *2	3
		304 SST (L form) *2	4
		Carbon steel (Flat form) *3	5
		304 SST (Flat form) *3	6

- Note) *1 In case Manifold valve is used and in case code C, D is used, please select code A1 of Option.
 *2 Applicable for wetted parts of material (center body); 316 SST (GTX31D, 41D, 71D) and ASTM B575 (GTX31D, 41D).
 *3 Applicable for wetted parts of material (center body); Tantalum (GTX31D, 41D, 71D), 316L SST (GTX31D, 41D, 71D) and ASTM B575 (GTX71D).
 *4 304 SST bolts and nuts material (-B) must be selected when PVC meterbody cover is selected. The max. working pressure is 1.5MPa.
 *5 When 304 SST bolt/nut is selected, max working pressure rating is 10MPa(100kgf/cm²).
 *6 In case code C, or D is selected, code A, or B of Process installation should be selected.
 *7 In case code J is selected, code C "Tantalum" of Material (centerbody) should be selected.
 *8 Please select A1 of option, when a wetted parts ASTM B575 of GTX71D is selected for assembling a manifold valve.
 *9 In case GTX71D, code C cannot be selected.
 *10 In case PVC is selected, code A, or D of Process connections should be selected.
 *11 In case PVC is selected, code A, or B of Process installation should be selected.
 *12 Not applicable for the combination with code F1 "FM Explosion proof" of Explosion proof.

*13 When a wetted parts ASTM B575 of GTX71D is selected, code A or B of process installation should be selected.

(Continued)

(Continued from previous page)

Model No.:GTX__D-Selection I(I II III IV V VI VII)-Selection II(I II III IV V VI)-Option

Option		
	No options	XX
	Adapter flange for corrosion-resistant application (316L SST or Tantalum for the wetted parts of centerbody)	A1
	With external Zero/Span adjustment *11	A2
	One elbow (left) *6*7*10	G1
	One elbow (right) *6*7*10	G2
	2 elbows *6*8*10	G3
	Long vent/drain plugs	G4
	Side vent/drain top *6	G6
	Side vent/drain bottom *6	G7
	Oil and water free finish	K1
	Oil free finish *4	K3
	Au Plating Diaphragm *12	L1
	Safety Transmitter *5	Q1
	NAMUR NE43 Compliant Output Signal Limits:3.8 to 20.5mA (Output 21.6mA/selected upper limit, 3.6mA/selected lower limit)	Q2
	Alarm Output (contact output)	Q7
	Custom calibration	R1
	Test report	T1
	Mill certificate	T2
	Traceability certificate	T4
	NACE certificate *9	T5
	Non SI Unit	W1

- Note) *4 No need to select when Fill Fluid code H, or J is selected.
 *5 Not applicable for the combination with code A2, or Q7 of Option.
 *6 Not applicable for the combination with code A, or B of Process installation.
 *7 Not applicable for the combination with code F1 "FM Explosion proof" of Explosion proof.
 *8 Not applicable for any Explosion proof. Please select code XX "None" of Explosion proof.
 *9 Applicable for "ASTM B575", code B of Material (center body).
 *10 Not applicable for the combination with code B "M20, Watertight" electrical connection.
 *11 Not applicable for the combination with code X "None" of Indicator. Please select "With indicator".
 *12 Not applicable for the combination with "Tantalum" of diaphragm material.

Model GTX32D(High static pressure type for standard differential pressure)

Model GTX42D(High static pressure type for high differential pressure)

Model GTX72D(High static pressure type for highest differential pressure)

Model No.:GTX__D-Selection I(I II III IV V VI VII)-Selection II(I II III IV V VI)-Option

Basic Model No.

	Measuring span	0.5 to 100kPa (50 to 10160mmH ₂ O)	GTX32D
		35 to 700kPa (0.35 to 7kgf/cm ²)	GTX42D
		0.25 to 14MPa (2.5 to 140kgf/cm ²)	GTX72D

Selection I

I	Output	4 to 20mA (SFN Communication)	A
		4 to 20mA (HART Communication)	B
II	Fill fluid	Regular type (Silicone oil)	A
		For oxygen service (Fluorine oil)	H
III	Material (Meter body cover, Vent/ Drain plugs)	Meterbody cover	Vent / Drain plugs
		316 SST	
IV	Material (center body)	316 SST (Diaphragm:316L SST)	
		A	
V	Process connections	Rc 1/4, without adapter flange	C
		1/4 NPT internal thread, without adapter flange	F
VI	Process installation	Vertical piping, top connection	A
		Vertical piping, bottom connection	B
VII	Bolt/nut	Carbon steel	A
		304 SST *5	B
		630 SST	C

Selection II

			-
I	Electrical connection	1/2 NPT, Watertight	A
		M20, Watertight *6	B
II	Explosion proof	None	XX
		FM Explosion proof	F1
		FM Intrinsically safe	F2
		FM Nonincendive	F5
		ATEX Explosion proof	A1
		ATEX Intrinsically safe	A2
		ATEX Type n	A5
		IECEX Explosion proof,	E1
		IECEX Intrinsically safe	E2
		IECEX Type n	E5
		NEPSI Explosionproof	N1
		NEPSI Intrinsically safe	N2
		NEPSI Type n	N5
III	Indicator	None	X
		With indicator	A
IV	Paint	Standard	X
		Corrosion-proof	B
		Corrosion-resistant (Silver coating)	D
V	Failure alarm	Upper limit of output at abnormal condition	A
		Lower limit of output at abnormal condition	B
VI	Mounting Bracket	None	X
		Carbon steel (Flat form)	5
		304 SST (Flat form)	6

Note) *5 When 304 SST bolt/nut is selected, max working pressure rating is 23MPa(230kgf/cm²).

*6 Not applicable for the combination with code F1 "FM Explosion proof" of Explosion proof.

(Continued)

(Continued from previous page)

Model No.:GTX__D-Selection I(I II III IV V VI VII)-Selection II(I II III IV V VI)-Option

Option		
	No options	XX
	Adapter flange for corrosion-resistant application (316L SST or Tantalum for the wetted parts of centerbody)	A1
	With external Zero/Span adjustment *11	A2
	One elbow (left) *6*7*10	G1
	One elbow (right) *6*7*10	G2
	2 elbows *6*8*10	G3
	Long vent/drain plugs	G4
	Side vent/drain top *6	G6
	Side vent/drain bottom *6	G7
	Oil and water free finish	K1
	Oil free finish *4	K3
	Au Plating Diaphragm	L1
	Safety Transmitter *5	Q1
	NAMUR NE43 Compliant Output Signal Limits:3.8 to 20.5mA (Output 21.6mA/selected upper limit, 3.6mA/selected lower limit)	Q2
	Alarm Output (contact output)	Q7
	Custom calibration	R1
	Test report	T1
	Mill certificate	T2
	Traceability certificate	T4
	NACE certificate *9	T5
	Non SI Unit	W1

- Note) *4 No need to select when Fill Fluid code H, or J is selected.
 *5 Not applicable for the combination with code A2, or Q7 of Option.
 *6 Not applicable for the combination with code A, or B of Process installation.
 *7 Not applicable for the combination with code F1 "FM Explosion proof" of Explosion proof.
 *8 Not applicable for any Explosion proof. Please select code XX "None" of Explosion proof.
 *9 Applicable for "ASTM B575", code B of Material (center body).
 *10 Not applicable for the combination with code B "M20, Watertight" electrical connection.
 *11 Not applicable for the combination with code X "None" of Indicator. Please select "With indicator".

DIMENSIONS

Model GTX 31D/41D (Material (center body): 316 SST, ASTM B575)
GTX 71D (Material (center body): 316 SST)

Process Connection : Front Side

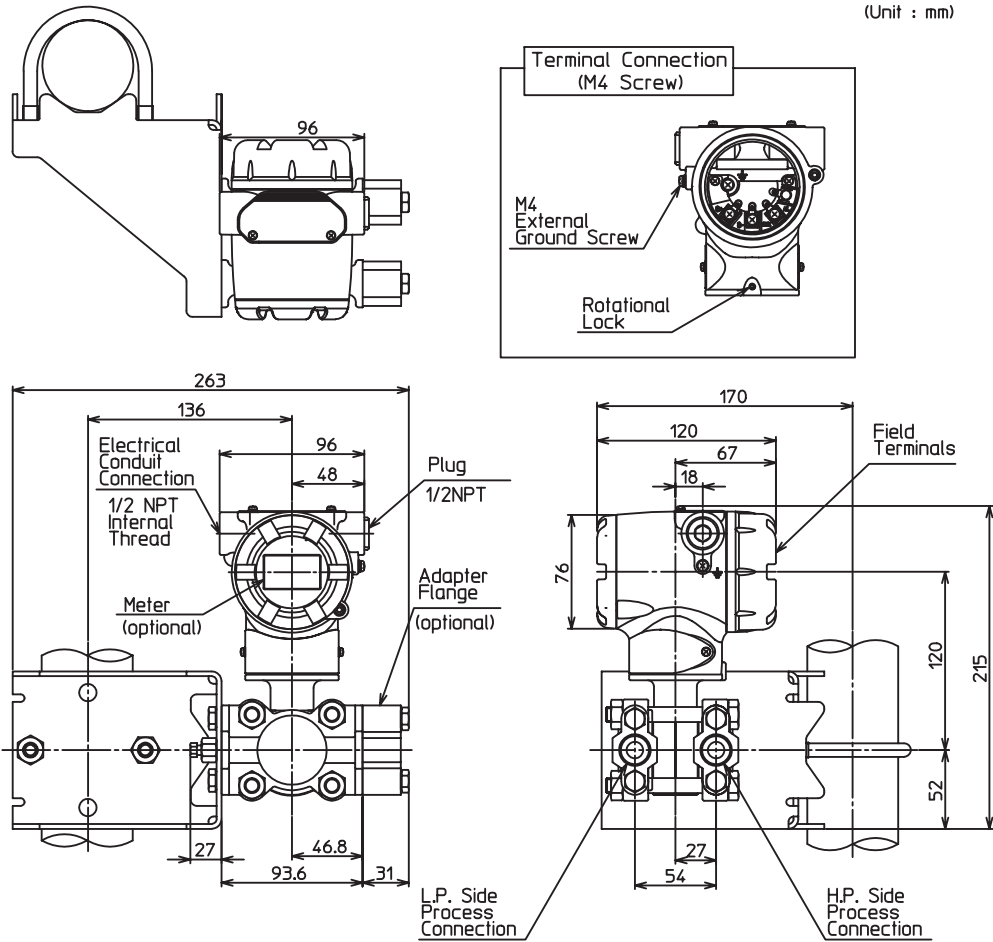

Process Connection : Top or Bottom Side

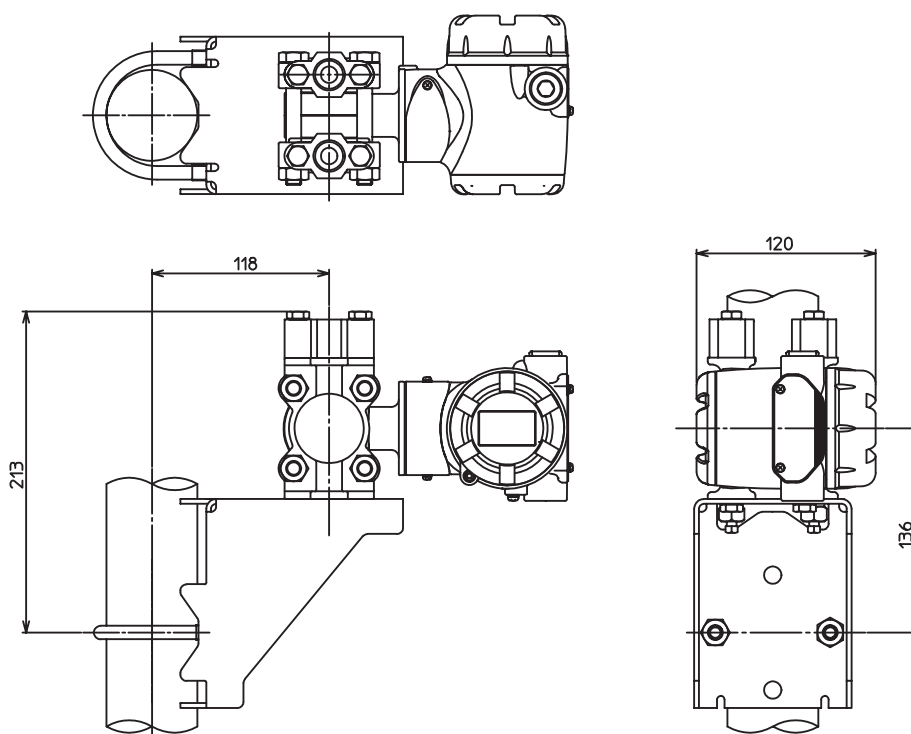

Model GTX 32D/42D/72D

(Unit : mm)

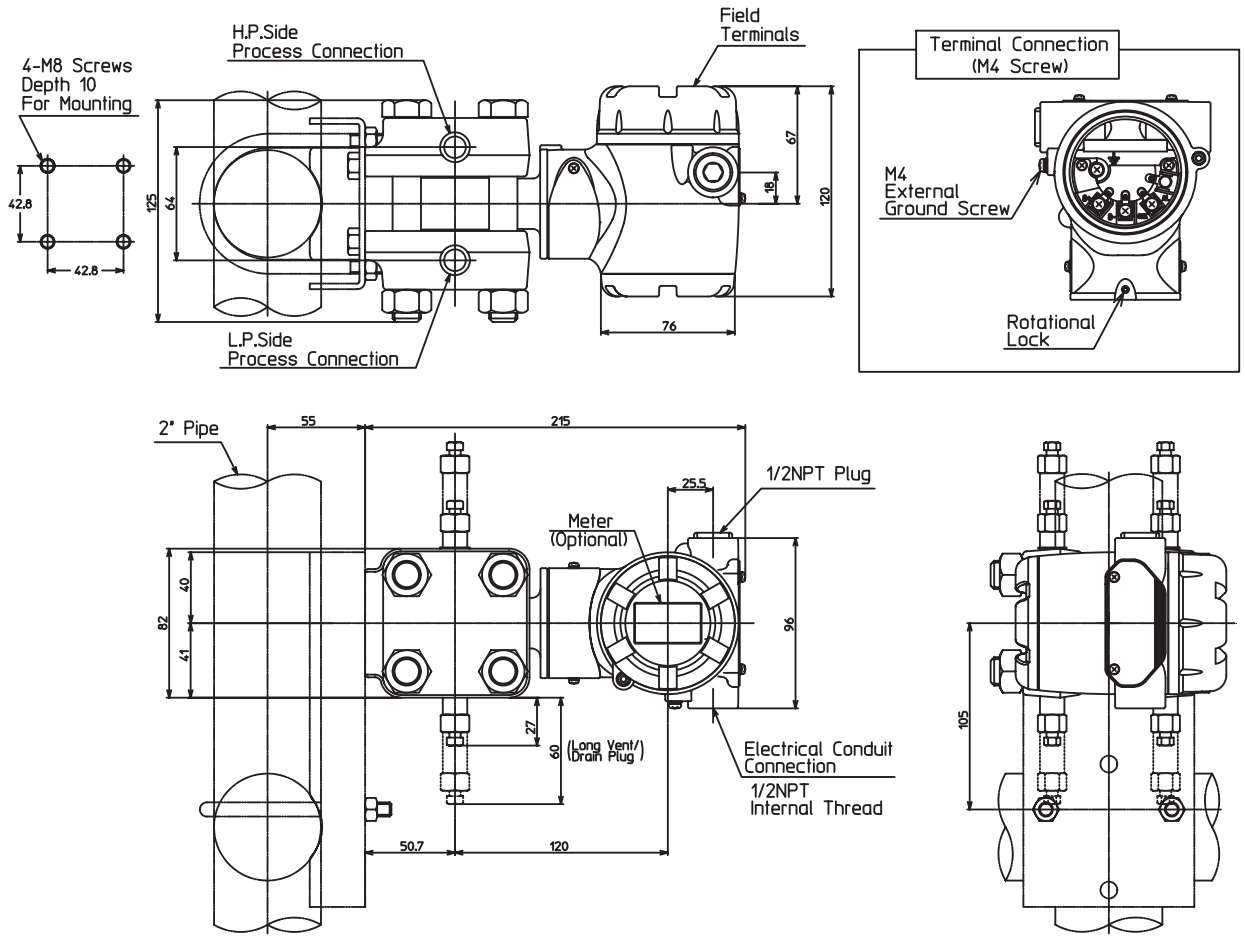

Model GTX 31D/41D (Material (center body): Tantalum, 316L SST)
 GTX 71D (Material (center body): Tantalum, 316L SST, ASTM B575)

(Unit : mm)

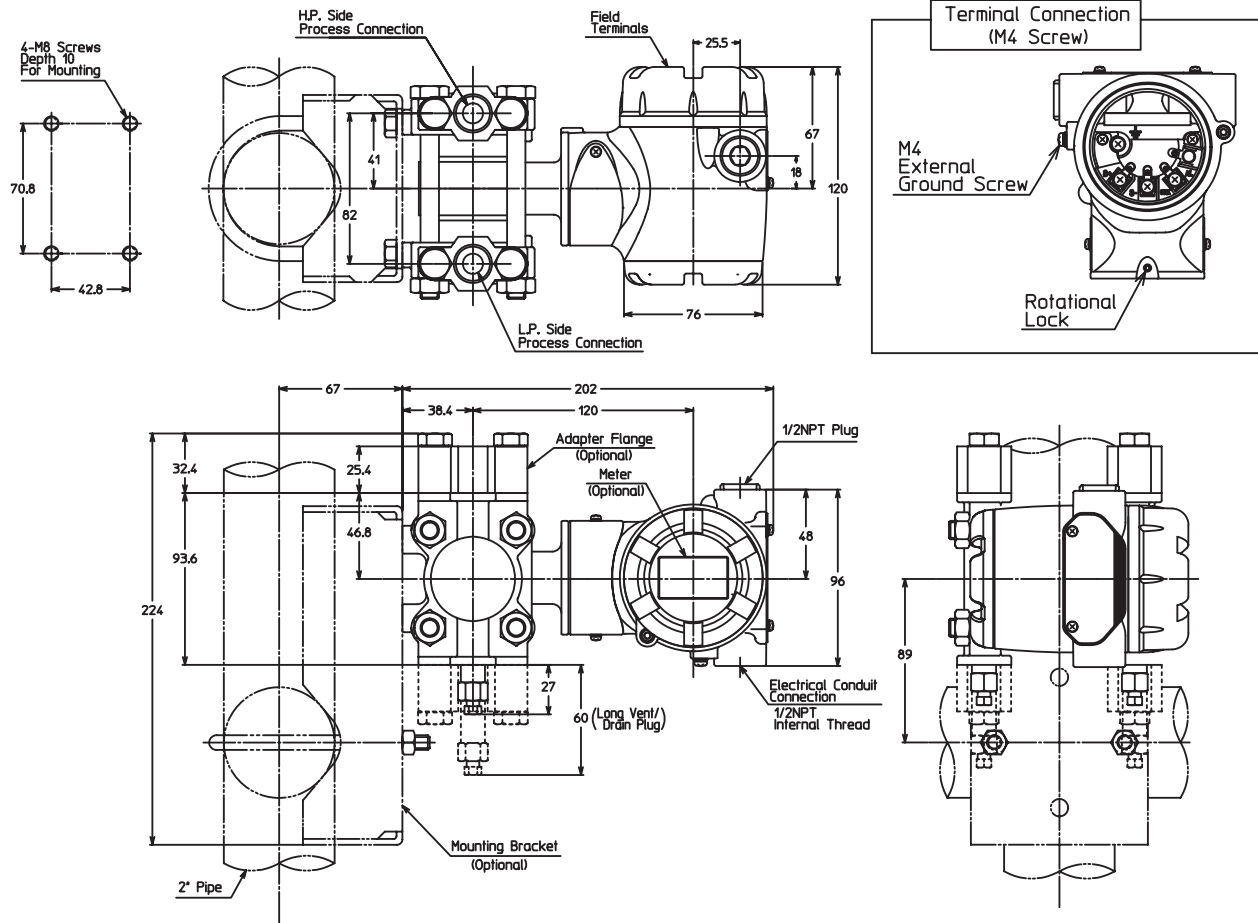

GTX 31D/41D (Material (Meter body cover, Vent/Drain plugs: PVC)

(Unit : mm)

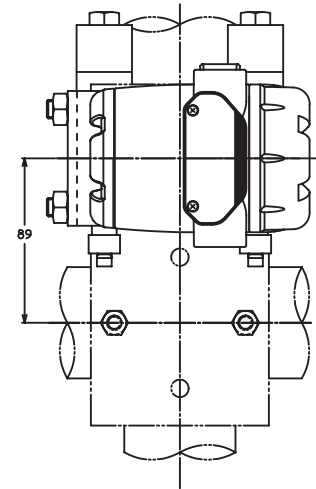
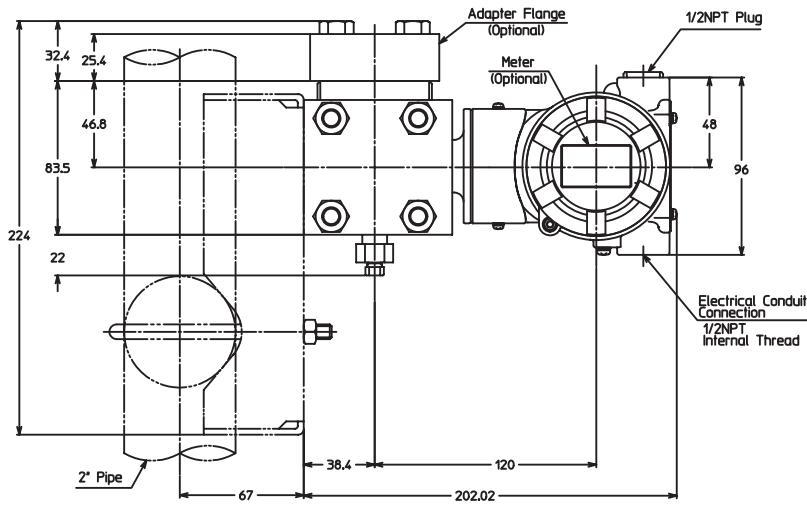
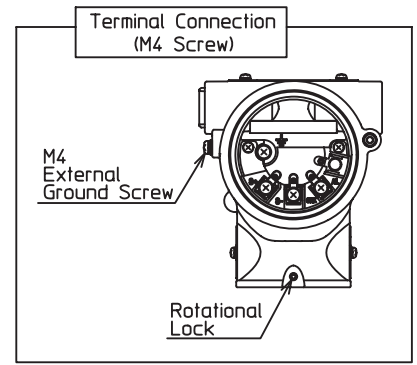
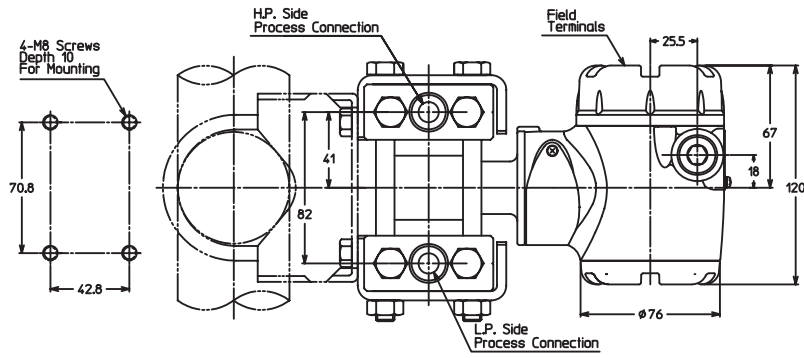

Specifications are subject to change without notice.

azbil

Yamatake Corporation
Advanced Automation Company

1-12-2 Kawana, Fujisawa-shi
Kanagawa-ken 251-8522 Japan

URL:<http://www.azbil.com>

No part of this publication may be reproduced or duplicated without the prior written permission of Yamatake Corporation.

May 2008 –Y/Y
Nov. 2009 (rev.8) –Y/Y